



TUSReportV2 Version 2

Temperature Uniformity Survey

YOKOGAWA Deutschland GmbH
Broichhofstraße 7-11
40880 Ratingen / Germany
Tel. +49 - 2102 - 4983 – 0

Contents:

1.	Introduction	4
2.	Revision	4
3.	System Requirements	5
3.1	Hardware	5
3.2	Software.....	6
3.3	Prerequisite	6
3.4	Operating System	6
1.	Download	7
1.1	Internet Explorer Message.....	7
2.	Starting the program.....	8
3.	Settings.....	9
3.1	Data File informations	9
3.1.1	Template, Directory	9
3.2	Textfields (Fields)	10
3.2.1	Free defined Labels	10
3.2.2	Put file name and date into footer	11
3.1	Comments.....	11
3.1.1	User definable comments.....	11
3.2	Other.....	12
3.2.1	Temperature unit	12
3.2.2	Stabilisation Factor	12
3.3	Chart	13
3.3.1	Color settings	13
3.3.2	Line strength.....	13
3.3.3	Zoom range	13
3.4	Change language, License	14
3.4.1	Change Language.....	14
3.4.2	Create new language data.....	14
3.4.3	Serial number	15
3.4.4	Name	15
3.4.5	Overview page	15
3.4.6	Show extended data sheet / Advanced View	15
3.4.7	Tag/Name.....	15
3.4.1	Manual stabilisations selection	15
4.	Furnace templates	16
5.	Correction Factor templates	18
6.	Create Report/Test Protocol.....	20
6.1	Main	20
6.2	Thermocouple Correction factor	23
6.3	Enter comments.....	24
6.4	Create test protocol.....	25
7.	Print Report	29
8.	Generating Excel templates	30
8.1	Creating a template.....	30
8.2	Custom design template header/footer	32
8.3	Example data	32
9.	Info	33

10.	Error handling	34
10.1	Solve Problem by yourself.....	34
10.1.1	Check out “COM Add-Ins” dialog in Excel	34
10.1.2	Find the problem	36
10.1.3	Make sure your add-in is installed correctly and it is enabled	36
10.2	Before ask your Service Team.....	37

1. Introduction

The leading players from the aviation industry have set up a program for common working and management practice, under the name "Nadcap" (National Aerospace & Defense Contractors Accreditation). A part of the program is dedicated to the registration and documentation of component testing.

The program "TUSReport" [TUS = Temperature Uniformity Survey] for Microsoft Excel outputs the collected data from the test protocol and generates a report as documentation of the conducted test.

A requirement for these functions is the existence of the displays data files and/or the Event display files in a file on the windows PC. Through the FTP-client, a function of the Yokogawa recorders it is possible to store the files on the PC. An FTP-server program is required on the windows computer. This is a standard component in the Windows XP and all newer Windows operating systems as a special feature which requires activation. In other operating systems, the use of freeware or shareware FTP server is recommended. You can find further information in the user manual of the recorder or on our webpage.

For updates and changes about the program, please read the info file stored in the installation folder or contact your Yokogawa sales team.

2. Revision

Date	Version	Detail
05.2013	1	First creation TUSReport Version 2
09.2013	2	Update Recorder List and some chapter.
11.2013	3	Update Recorder List and some chapter.

3. System Requirements

3.1 Hardware

For the documentation of the test, a paperless Data recorder is required. The Data recorders listed below are supported by the Add in:

Recorder	File extension	Data type
GX20 / GP20 www.smartdaq.com	.GDS .GEV	Display Data Event Data
DX100 / DX200	.DDS .DEV	Display Data Event Data
DX1000 / DX1000N / DX2000 [DXAdvanced] www.DAQStation.com	.DAD .DAE	Display Data Event Data
DX1000 / DX1000N / DX2000 R4 [DXAdvanced R4]	.DSD .DSE	Display Data Event Data
FX100	.DDS .DEV	Display Data Event Data
DX100P / DX200P Pharma-Model	.DBD .DBE	Display Data Event Data
MW100 / MX100	.MXD	Data

For the analysis using a PC, the following minimum hardware requirements must be met.

- Hard disk capacity: 13 MB
- Memory: 1GB

3.2 Software

The program TUSReport Version 2 is Windows based and requires therefore a Windows Operating System.

3.3 Prerequisite

- Windows .Net Framework 4 Full installation (is checked by setup)
 - o <http://www.microsoft.com/en-us/download/details.aspx?id=17718>
- Microsoft OFFICE .NET Framework (VSTO) installation (is checked by setup)
 - o <http://www.microsoft.com/en-us/download/details.aspx?id=35594>

3.4 Operating System

The program has been tested on the following platforms:

- Windows XP Professional SP2
- Windows 7 [32bit]
- Windows 7 [64bit]
- Windows 8 [64bit]



Note:

Operation under Windows 8 has not been fully tested at the time of writing this manual.

Also the program Microsoft Excel is required.

The program has been tested with the following Microsoft Excel Software versions:

- Microsoft Excel 2010 [32Bit]
- Microsoft Excel 2013 [32Bit]

1. Download

Load the latest version of our solution from the following web Page:

<http://www.AdvancedTools.de>

Check there for “Version 2” and “TUSReport Version 2”.

1.1 Internet Explorer Message

If the Internet Explorer Function enables “SmartScreen Filter” you get sometime the following Message Window.

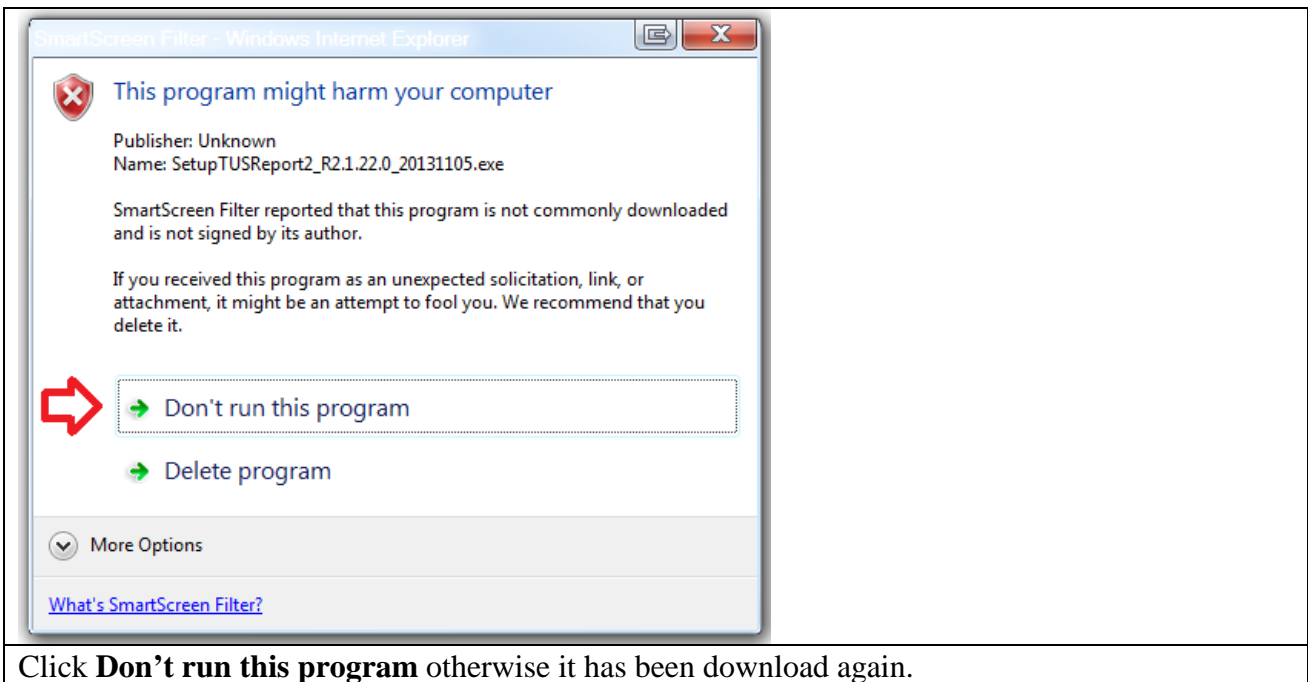
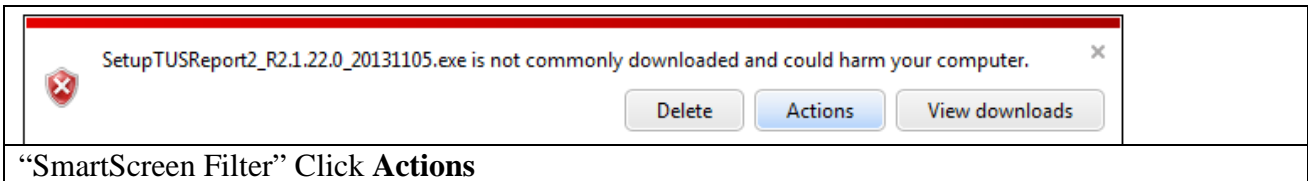

2. Starting the program

The program shows the header „TUS-Report“ in the Menu bar of Microsoft Excel.

The program is controlled via the add-in menu:

- Uniformity survey report
- Print
- Template creator
- Furnace Template
- T/C Correction Factor
- Settings
- Error Handling
- Info

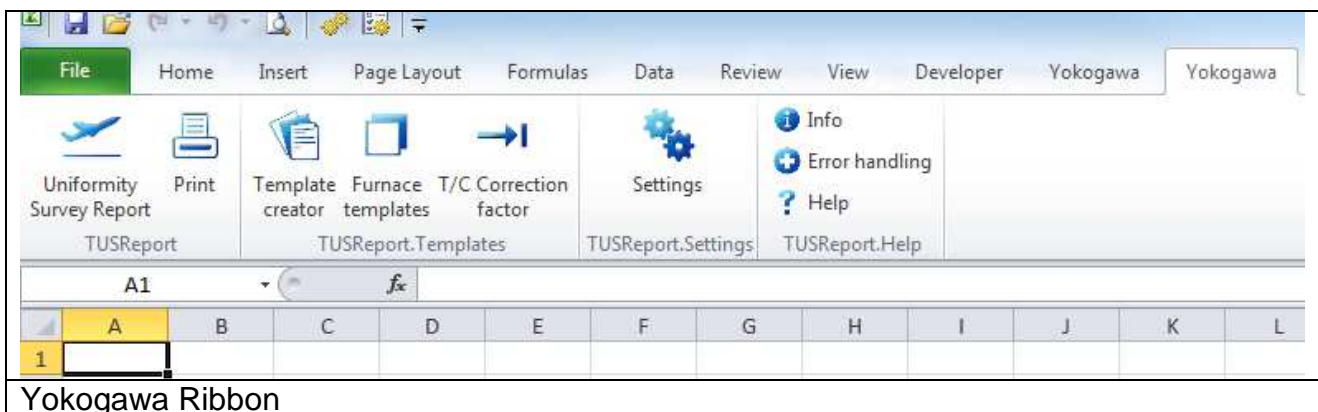

The individual menu items are explained in the following chapters.



Tip: After successful installation, please check your settings (Menu item „Settings“).

3. Settings

Items under the menu choice “Settings” must be processed before the report creation.

Using the „Save“, „Cancel“ and „Transfer“ buttons, the settings are confirmed/rejected and are then made available in the report.

3.1 Data File informations

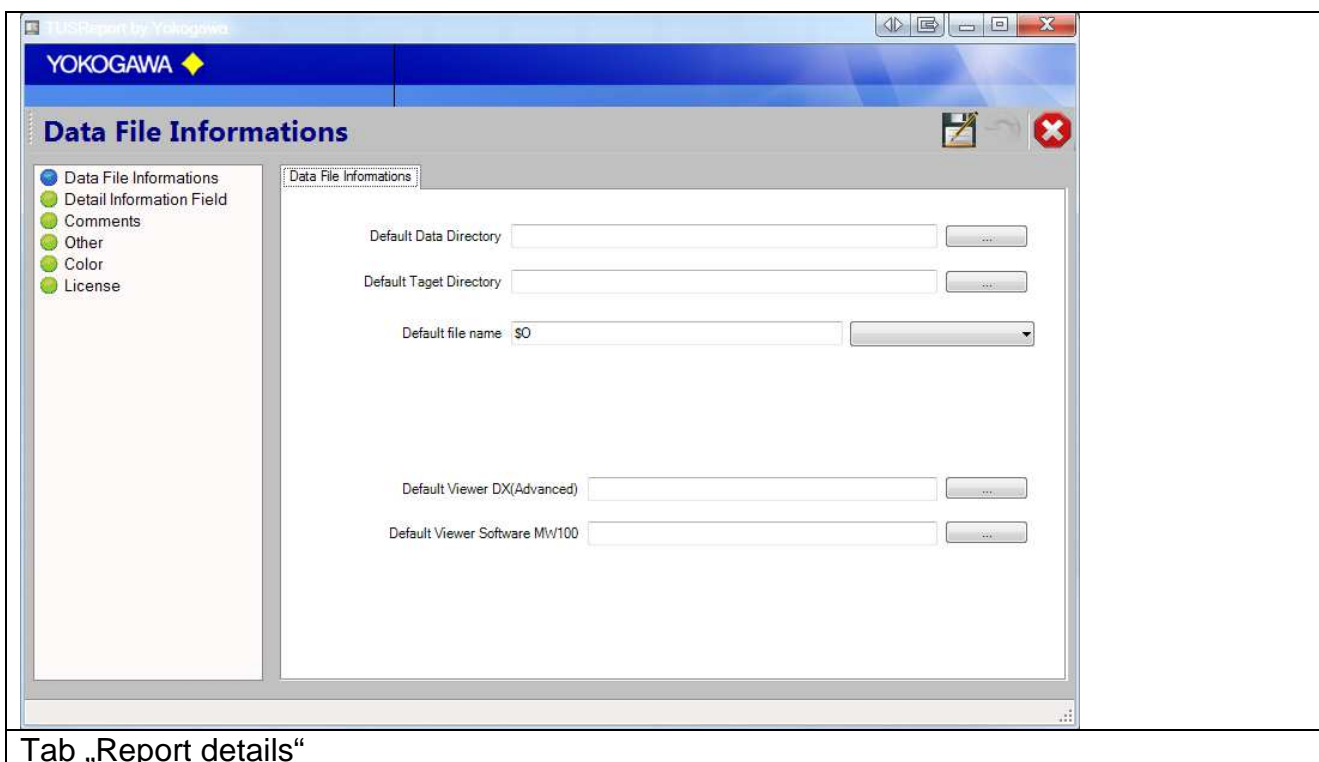

3.1.1 Template, Directory

In order to customize reports to your specific needs reports can have special header sheets applied.

Under „default template“ a Excel sheet can be defined as the default template. At the report generation the template can still be changed for another.

The standard template defines the folder location to look for the data file and where to send the completed report.

These settings will also be requested / confirmed during the composition of the report.

With „Report filename“ the name of the finished report is defined.

Use the following sign for a predefined name:

\$T01 bis \$T14	Entry of the 14 user definable text fields
\$HH	Hour of the first file
\$mm	Minute of the first file
\$SS	Second of the first file
\$DD	Day of the first file
\$MM	Month of the first file
\$YY / \$YYYY	Year of the first file (08 or 2008)
\$O	Original file name of the first file

In the expanded display, the stabilization point is shown for each file in the report.

Insert the path to the Software DAQStandard Viewer into the „Viewer“-Text field.

3.2 Textfields (Fields)

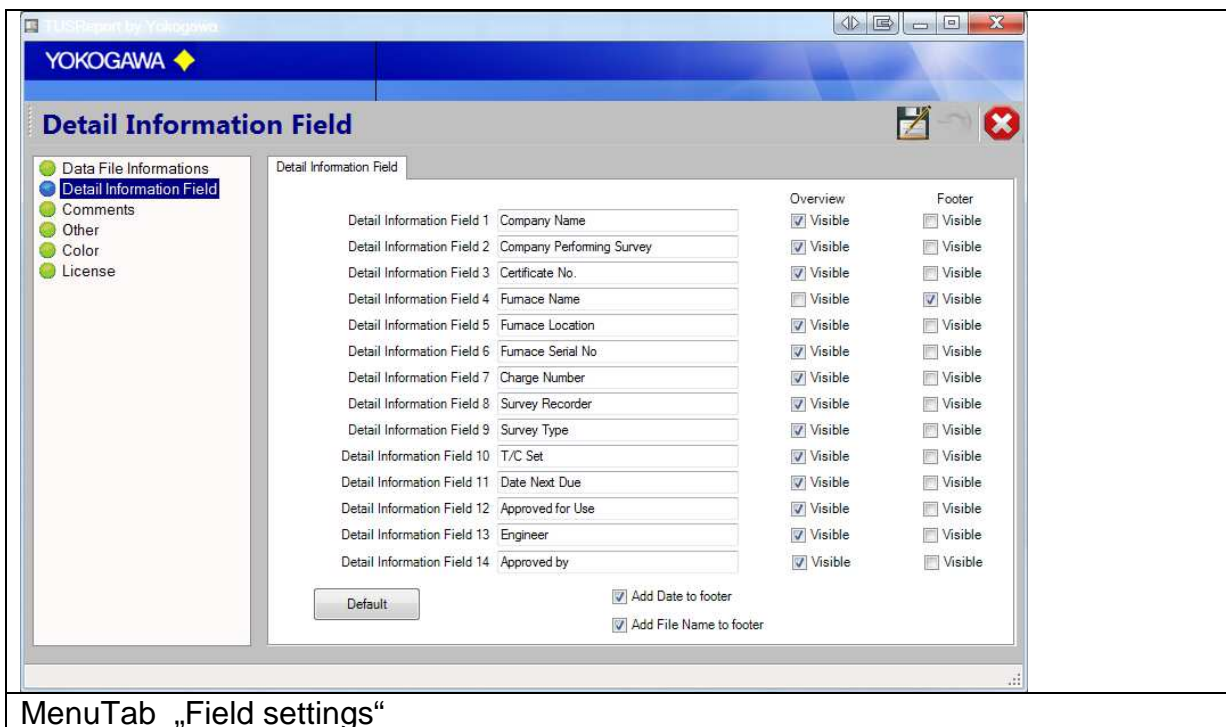

MenuTab „Field settings“

3.2.1 Free defined Labels

There are 14 user definable text fields available for selection. These can be displayed in the test overview or footer of the report. The position of these fields in the report can be set using the checkboxes.

If the checkboxes unchecked or the text field is empty, in the main form the text field is invisible.

3.2.2 Put file name and date into footer

Please check these fields to put the information into the footer of each page.

3.1 Comments

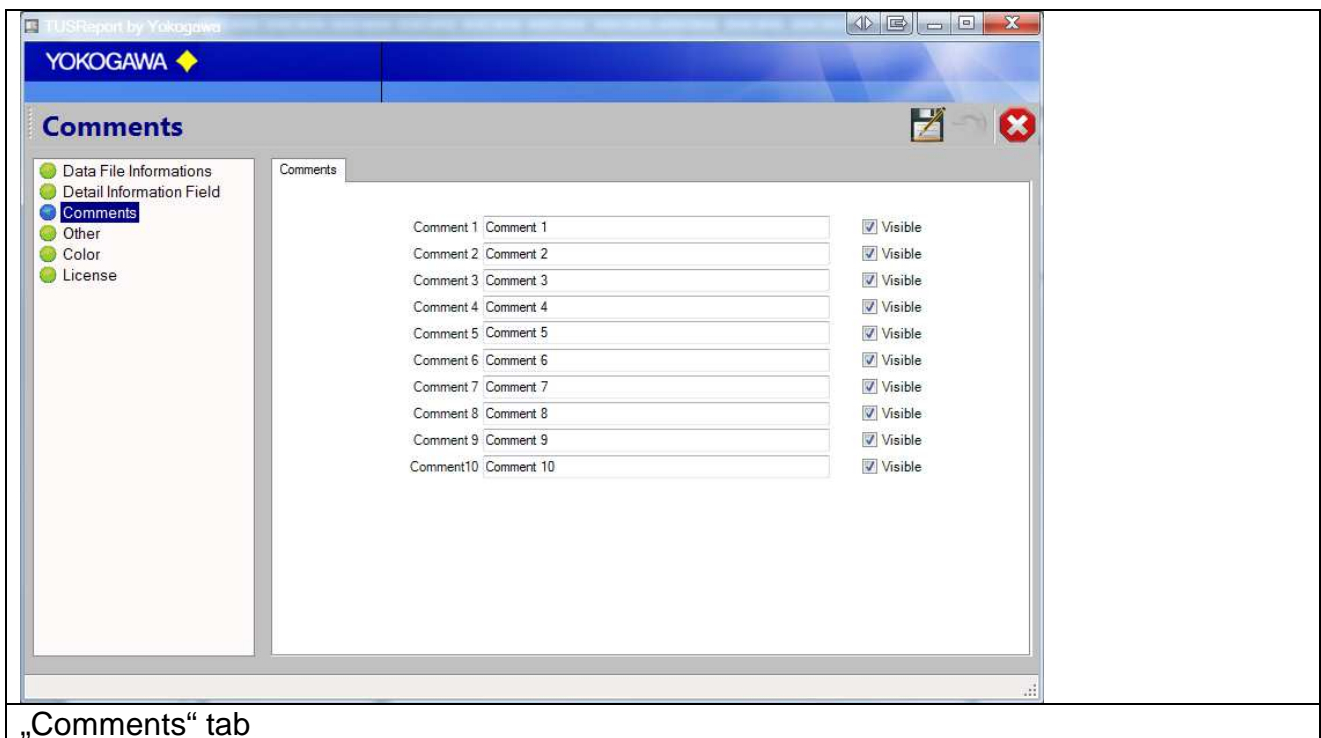

3.1.1 User definable comments

For better definition of comment fields in the main body, extended comments can be entered here.

If the text field is empty, in the main form the comment field is invisible.

3.2 Other

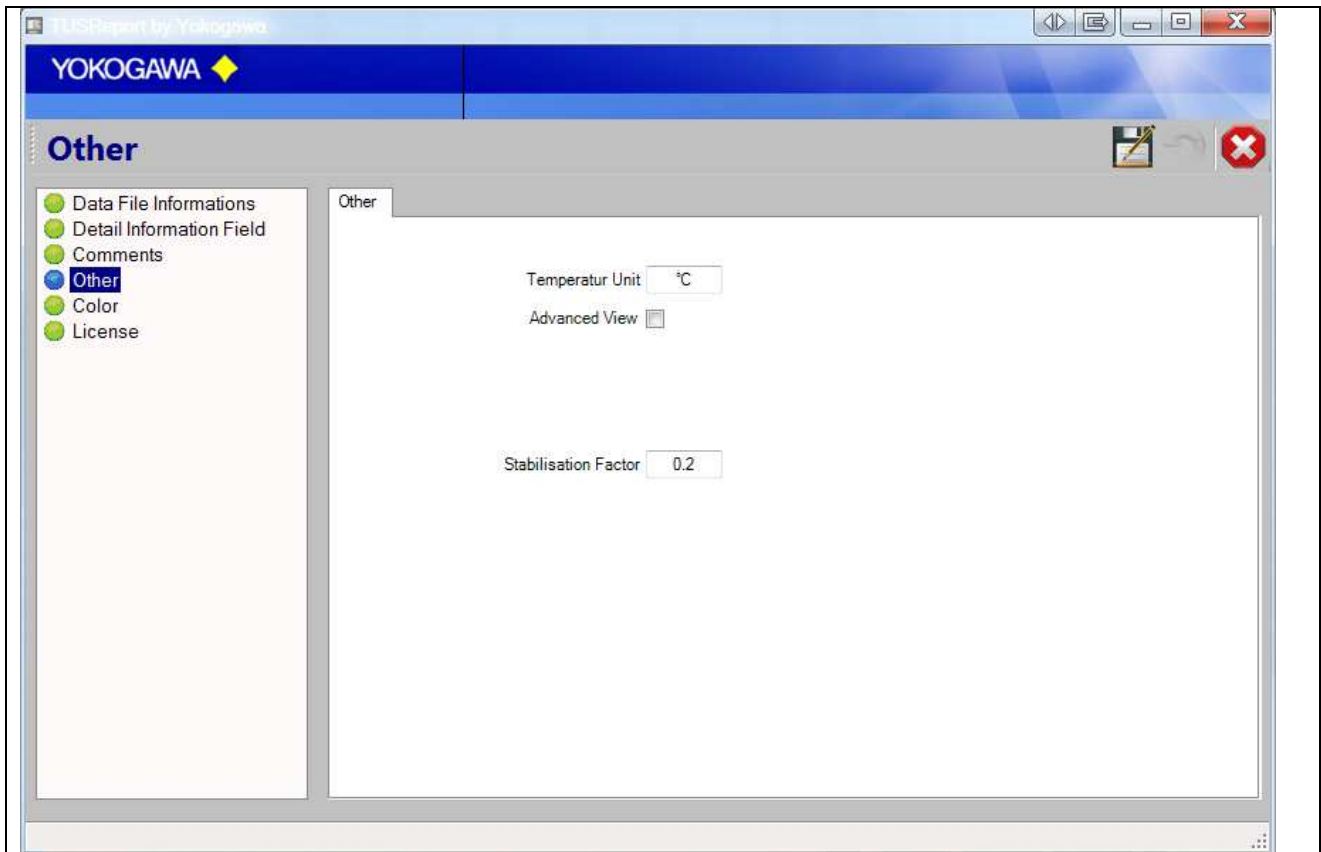

Setting tab „Data file“

If a DXAdvanced is chosen, there is the additional possibility to enter channel calibration correction data into the test (CC1 option).

3.2.1 Temperature unit

If another temperature unit is required, this can be entered here [DegC; °F].

3.2.2 Stabilisation Factor

With the stabilisation factor the maximum divergence of the measuring value is defined over a period of 6 minutes.

3.3 Chart

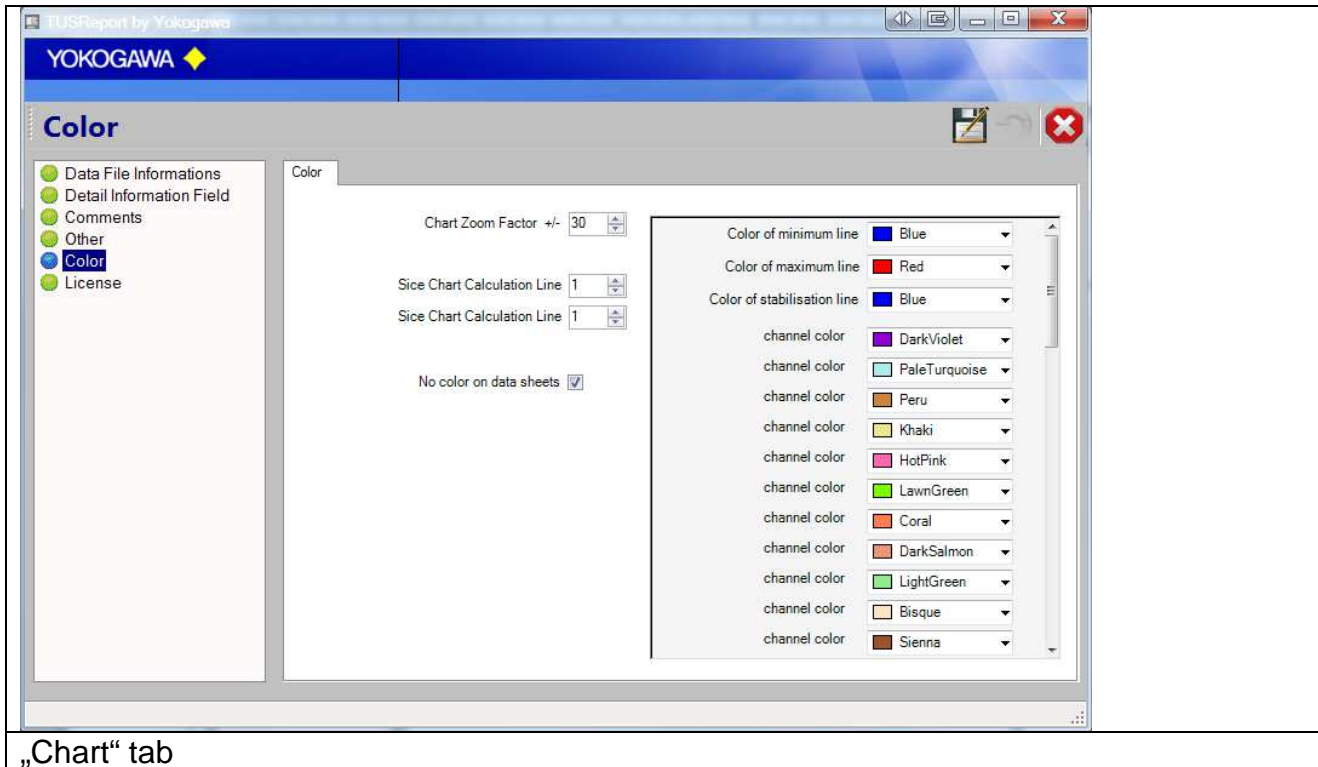

„Chart“ tab

3.3.1 Color settings

With this tab it is possible to change the line colors for the charts. The Min/Max values colors are settings with the Color Table value.

3.3.2 Line strength

The line strength of the individual trend lines can be between 4 strengths can be selected.

3.3.3 Zoom range

The zoom factor defines the range over and under the test temperature. The value Null set the factor to default.

3.4 Change language, License

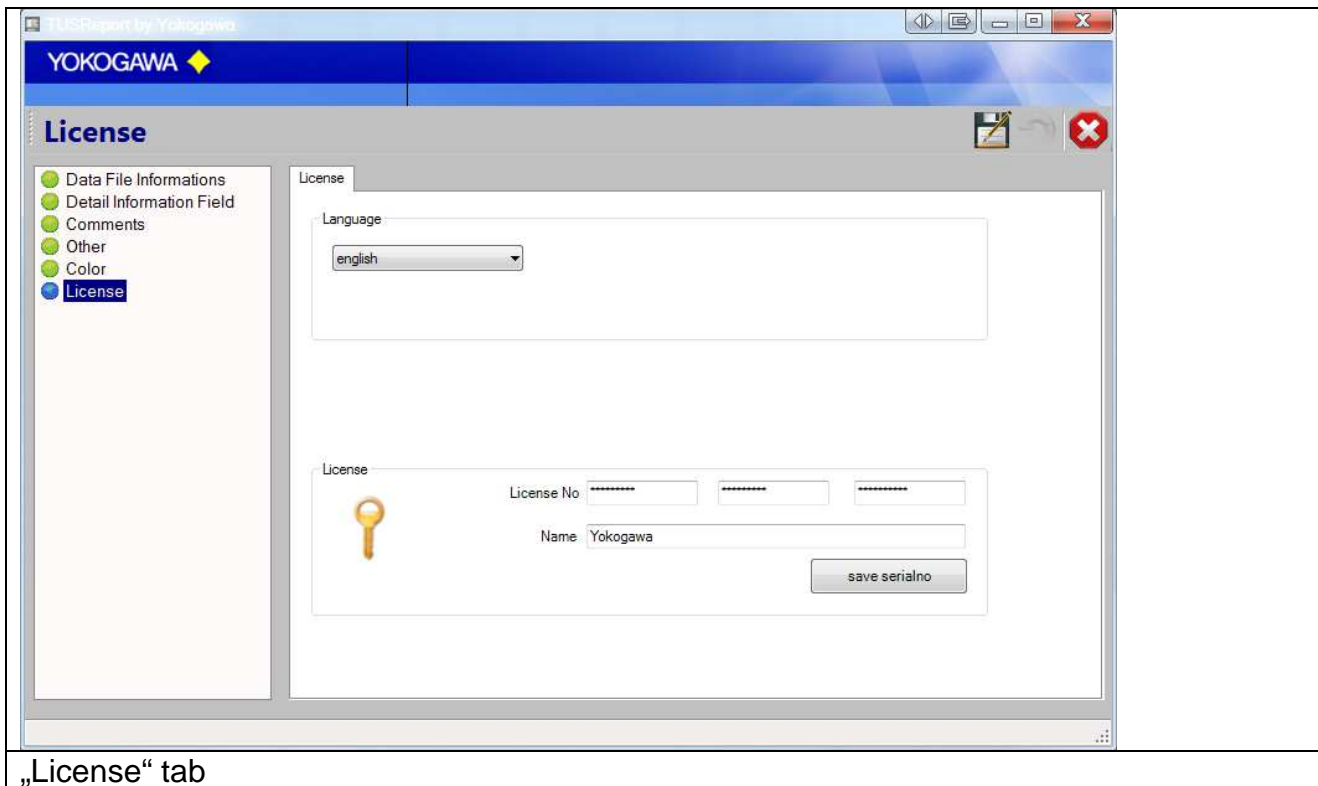

„License“ tab

3.4.1 Change Language

By using the button „Language“ the program can be set to another language. Once another language is selected, this will be implemented immediately. Please re-start the program to ensure proper operation after this step.

3.4.2 Create new language data

It is possible to translate the program into many different languages.

To create a new language, perform the following steps:

1. Copy the file „english.lng“ from the Installation directory to a temporary directory.
2. Re-name the file according to the new language e.g: “French.lng“.
3. Open the file and change the text behind the =-symbol.
4. Save the new file you just created and copy back to the original installation directory.
5. The new language can be selected in Excel after re-starting.

3.4.3 Serial number

If the software is installed in demo mode, entering a valid serial number and clicking on the „save license“-button will unlock the software.

3.4.4 Name

Under „Name“ (company) enter your company name.

A serial number with the registered company name can be obtained from Yokogawa Deutschland GmbH.

3.4.5 Overview page

The results of each test will be shown on one sheet as default. By changing this option it will be create a separate overview page for the each test.

3.4.6 Show extended data sheet / Advanced View

By activation of these functions, the software put more information into the report sheets.

3.4.7 Tag/Name

If the appropriate channels have been given tag names, these will be shown in the report. If no tag names are defined, the channel number will be shown instead.

3.4.1 Manual stabilisations selection

With the stabilization selection, it is possible to the stabilization time manual. The calculated stabilization time will be set as default value.

4. Furnace templates

With the furnace template it is possible to create a template for a lot of furnace with different settings.

Use the button Add, Change, delete and Save to modify the entry values for the different furnaces.

Field	Value	Visible	Visible
Company Name	Yokogawa Deutschland	<input checked="" type="checkbox"/>	<input type="checkbox"/>
Company Performing Survey	BestFurnaceCompany	<input checked="" type="checkbox"/>	<input type="checkbox"/>
Certificate No.	Cert. ABC123	<input checked="" type="checkbox"/>	<input type="checkbox"/>
Furnace Name	Furnacer Number 1	<input checked="" type="checkbox"/>	<input checked="" type="checkbox"/>
Furnace Location	Station 3	<input checked="" type="checkbox"/>	<input type="checkbox"/>
Furnace Serial No	SER12345	<input checked="" type="checkbox"/>	<input type="checkbox"/>
Charge Number	CUST20130405	<input checked="" type="checkbox"/>	<input type="checkbox"/>
Survey Recorder	Yokogawa DXAdvanced	<input checked="" type="checkbox"/>	<input type="checkbox"/>
Survey Type	Periodic	<input checked="" type="checkbox"/>	<input type="checkbox"/>
T/C Set	XYZ	<input checked="" type="checkbox"/>	<input type="checkbox"/>
Date Next Due	10/12/2013	<input checked="" type="checkbox"/>	<input type="checkbox"/>
Approved for Use	500Deg C - 2100 Deg C	<input checked="" type="checkbox"/>	<input type="checkbox"/>
Engineer	D. Jones	<input checked="" type="checkbox"/>	<input type="checkbox"/>
Approved by	M. van Cleve	<input checked="" type="checkbox"/>	<input type="checkbox"/>

Yokogawa

„Report Header Entry“ tab

There are 14 user definable text fields available for selection. These can be displayed in the test overview or footer of the report. To setup more than one Furnace Template use this tab.

Check chapter [3.2 Textfields (Fields)] for setting different text items for the report header.

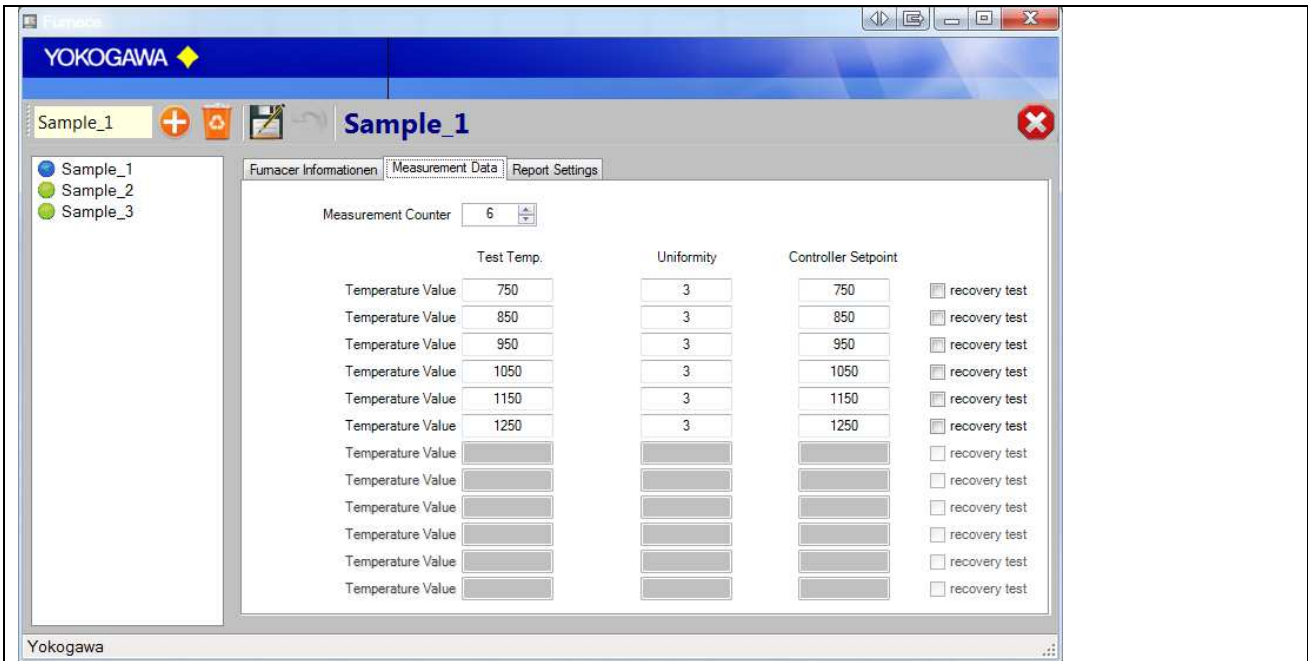

Data file

To set the different temperature settings and tests, use this tab.

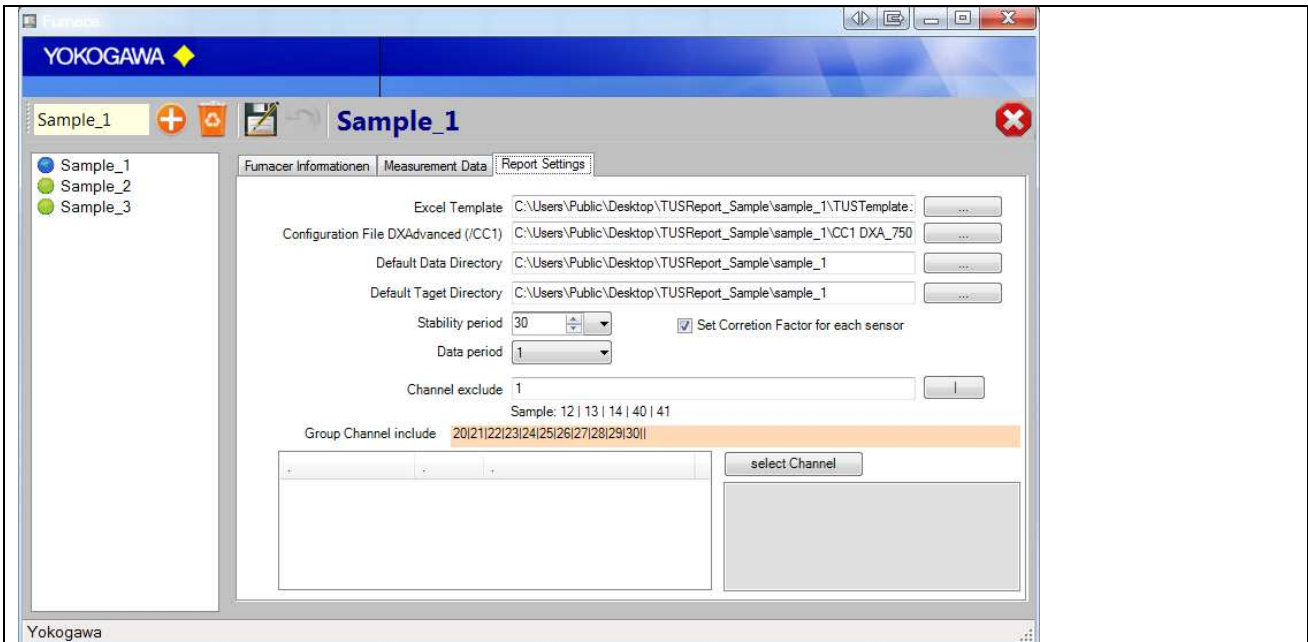

Report layout

On this tab it is possible to setup a different default template for each test/furnace. Also the stabilization test period is setup on this tab.

To exclude some channels, add the channels into the text box. The selected channels are not shown in the report.

Separate each channel with a pipe sign (|).

5. Correction Factor templates

With the correction factor template it is possible to create a template for a lot of different thermo couples.

Use the button Save and Cancel to modify the entry values for the different thermo couples.

Serial No	1	2	3	4	5	6	7	8	9	10
Serialno1	0.1	0.2	0.3	0.4	0.5	0.6	0	0	0	0
Serialno2	0.7	0.8	0.3	0.1	0.11	0.12	0	0	0	0
Serialno3	0.11	0.22	0.33	0.44	0	0	0	0	0	0
*										

Correction factor table

With this table it is possible to define 20 different < Thermo couple with Serial number and 12 temperature entry.

On Tab 2 of the creating report Form it is possible to select different Thermo couple. It is also possible to write manual settings into the fields.

TUSReport for NATCAP by Yokogawa

YOKOGAWA

Start your report --> Insert measurement data --> insert correction factor --> Finalize your report

Set Corretion Factor for each sensor 1112/4/5/6/7/8/9/10

Correctionfactor Templates: Sample

	500°C	750°C	950°C	1190°C
SURVEYT/C	0	0	0	0
SURVEYT/C	0	0	0	0
SURVEYT/C	0	0	0	0
SURVEYT/C	0	0	0	0
SURVEYT/C	0	0	0	0
SURVEYT/C	0	0	0	0
SURVEYT/C	0	0	0	0
LOADT/C	0	0	0	0
SURVEYT/C	0	0	0	0
SURVEYT/C	0	0	0	0

Yokogawa

Selection Combo box

6. Create Report/Test Protocol

Under the menu item „Uniformity Survey Report“, the test protocol is created.

The report assistant takes you through each point of the test protocol. There are three screens shown in total.

The individual settings are requested and checked for completeness.

6.1 Main

The highlighted window consists of two entry fields. The first part defines the free text fields. How to modify free text fields can be found in “Options” [3.2]. Use the combo box to change the entry.

The second part defines the measurement data’s common settings.

Each threshold has its own temperature, the maximum permissible deviation and the set point of the furnace temperature controller.

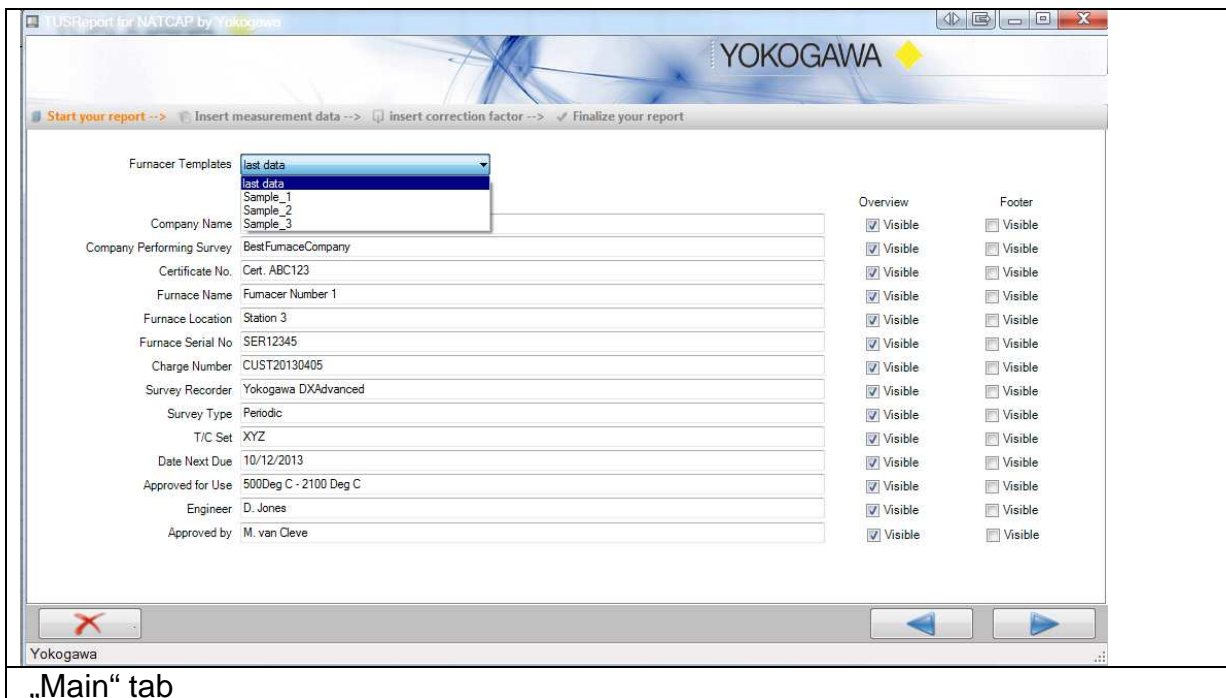

YOSReport for NATCAP by Yokogawa

YOKOGAWA

Start your report --> Insert measurement data --> Insert correction factor --> Finalize your report

Furnace Templates: last data (dropdown menu)

Company Name: []

Company Performing Survey: BestFurnaceCompany

Certificate No.: Cert. ABC123

Furnace Name: Furnace Number 1

Furnace Location: Station 3

Furnace Serial No.: SER12345

Charge Number: CUST20130405

Survey Recorder: Yokogawa DXAdvanced

Survey Type: Periodic

T/C Set: XYZ

Date Next Due: 10/12/2013

Approved for Use: 500Deg C - 2100 Deg C

Engineer: D. Jones

Approved by: M. van Cleve

Overview:

- Visible
- Visible
- Visible
- Visible
- Visible
- Visible
- Visible
- Visible
- Visible
- Visible
- Visible
- Visible
- Visible
- Visible

Footer:

- Visible
- Visible
- Visible
- Visible
- Visible
- Visible
- Visible
- Visible
- Visible
- Visible
- Visible
- Visible
- Visible

Yokogawa

„Main“ tab

Up to 12 test points can be entered.

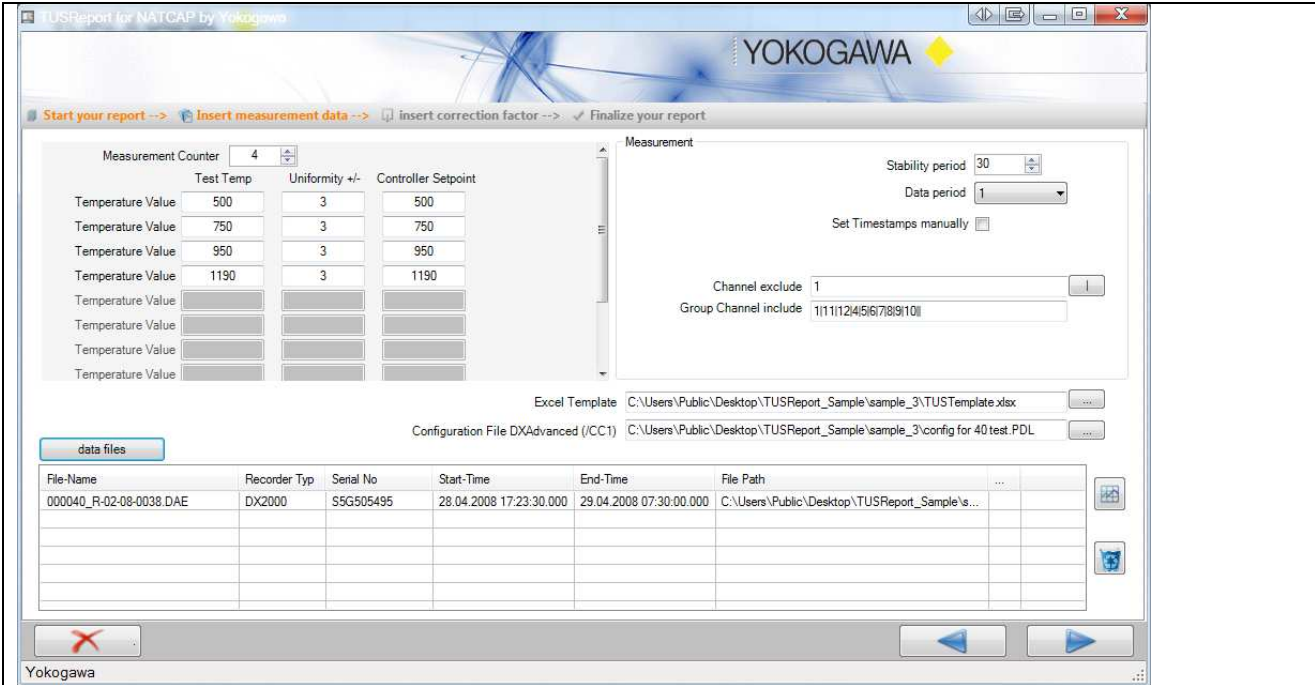

“Main” tab

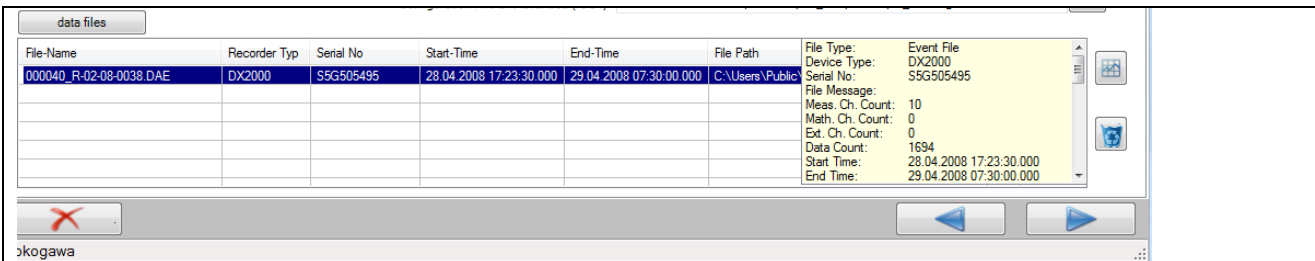

Add files

Using the **data files** button selects the data. The “Open data” window shows, when a point is selected, a small sample of the general data information. If an incorrect value is recognized, this field will be shown in red.



Tip:

Use the Drag and Drop function for an easy file selection.

If the DXAdvanced recorder selected, it is possible to add the configuration file with the CC1 option data. There is a separate page printed in the report for these details.

If it is necessary to enter additional correction factors, the checkbox “Correction factor” needs to be activated. With this function, the correction factor for each channel should be entered on the next page.

Activating the Checkbox „One correction factor per T/C set” reduces the number of correction factors per channel to one only.

The stability time defines the minimum duration of the stability in the respective temperature-profile.



Tip:

Most of these entries will be saved and with new tests it will not be necessary to re-enter all details.

During the test interval, data reduction takes place to simplify the report. Only the data in this interval are portrayed in the report. In addition all further relevant data outside of this interval are considered in the report and are portrayed in the overview.

Channel exclude	<input type="text" value="1"/>	<input type="button" value="↓"/>
Group Channel include	<input type="text" value="1 1 1 2 4 5 6 7 8 9 10 "/>	
Select different exclude Channel		

6.2 Thermocouple Correction factor

If all values are correctly entered, use the „Next“ button to continue.

In this window a serial number must be entered for each thermocouple. A separate text box is shown for each channel.

If the checkbox “Correction factor“ is activated, a textbox for each sensor at each measurement point is shown. The correction factors must be entered for each measurement point.

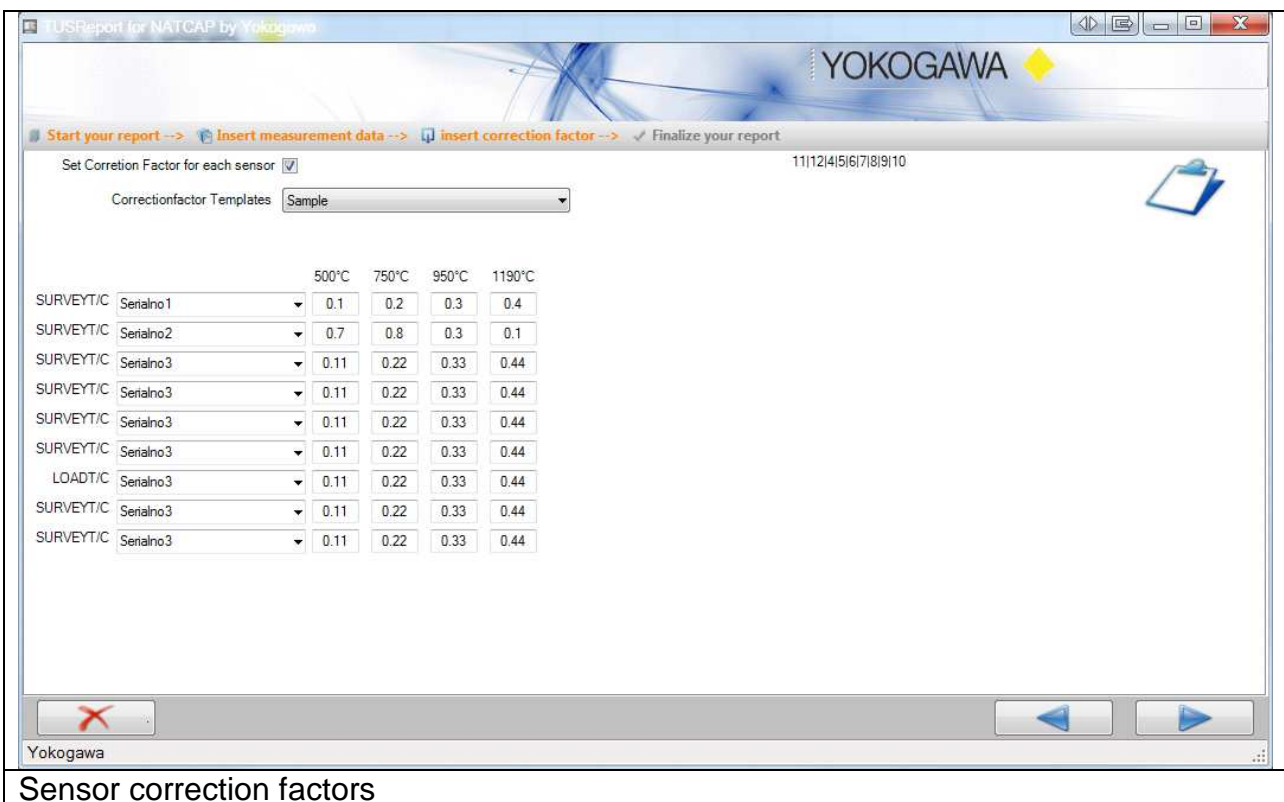

YOKOGAWA

Start your report --> Insert measurement data --> insert correction factor --> Finalize your report

Set Corretion Factor for each sensor

Correctionfactor Templates: Sample

		500°C	750°C	950°C	1190°C
SURVEYT/C	Serialno1	0.1	0.2	0.3	0.4
SURVEYT/C	Serialno2	0.7	0.8	0.3	0.1
SURVEYT/C	Serialno3	0.11	0.22	0.33	0.44
SURVEYT/C	Serialno3	0.11	0.22	0.33	0.44
SURVEYT/C	Serialno3	0.11	0.22	0.33	0.44
SURVEYT/C	Serialno3	0.11	0.22	0.33	0.44
LOADT/C	Serialno3	0.11	0.22	0.33	0.44
SURVEYT/C	Serialno3	0.11	0.22	0.33	0.44
SURVEYT/C	Serialno3	0.11	0.22	0.33	0.44

Yokogawa

Sensor correction factors

6.3 Enter comments

The final window of the „report assistant“ defines the comment fields. Definition of „free comment“ fields can be found in “Settings“ in section [5.4]

There are six fields which can be added. The first three are single sentence fields. In the remaining three, larger comments or notes can be added.

The comments are shown in the respective templates.

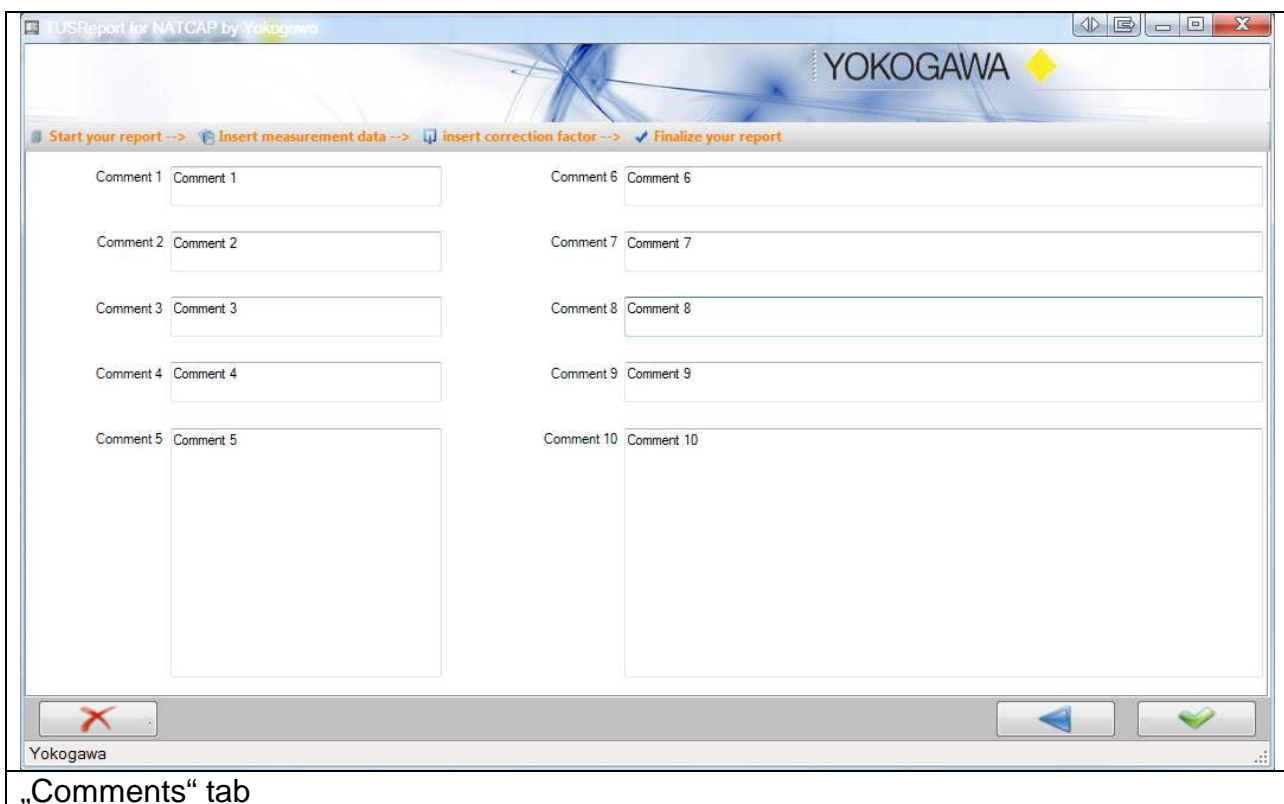

Yokogawa

„Comments“ tab

Stabilisation time (750)

Filename

Name	Recorder	Serial No	Start	End
000040_R-02-08-0038.DAE	DX2000	S5G505...	28.04.2008 17:23:30.000	29.04.2008 07:30:00.000

msgSetStabpoint

29.04.2008 03:09:00 --> 29.04.2008 03:09:00

29.04.2008 03:09:00

Set time manually

6.4 Create test protocol

After pressing „Create report“ the test will be run in the background.
A file with the following data sheets is generated:

- Cover sheet with graph
- Test_Data
- Overview
- DXA_CC1 (if selected)
- Actual temperature data in Tabular form
- Actual temperature data in graphical form

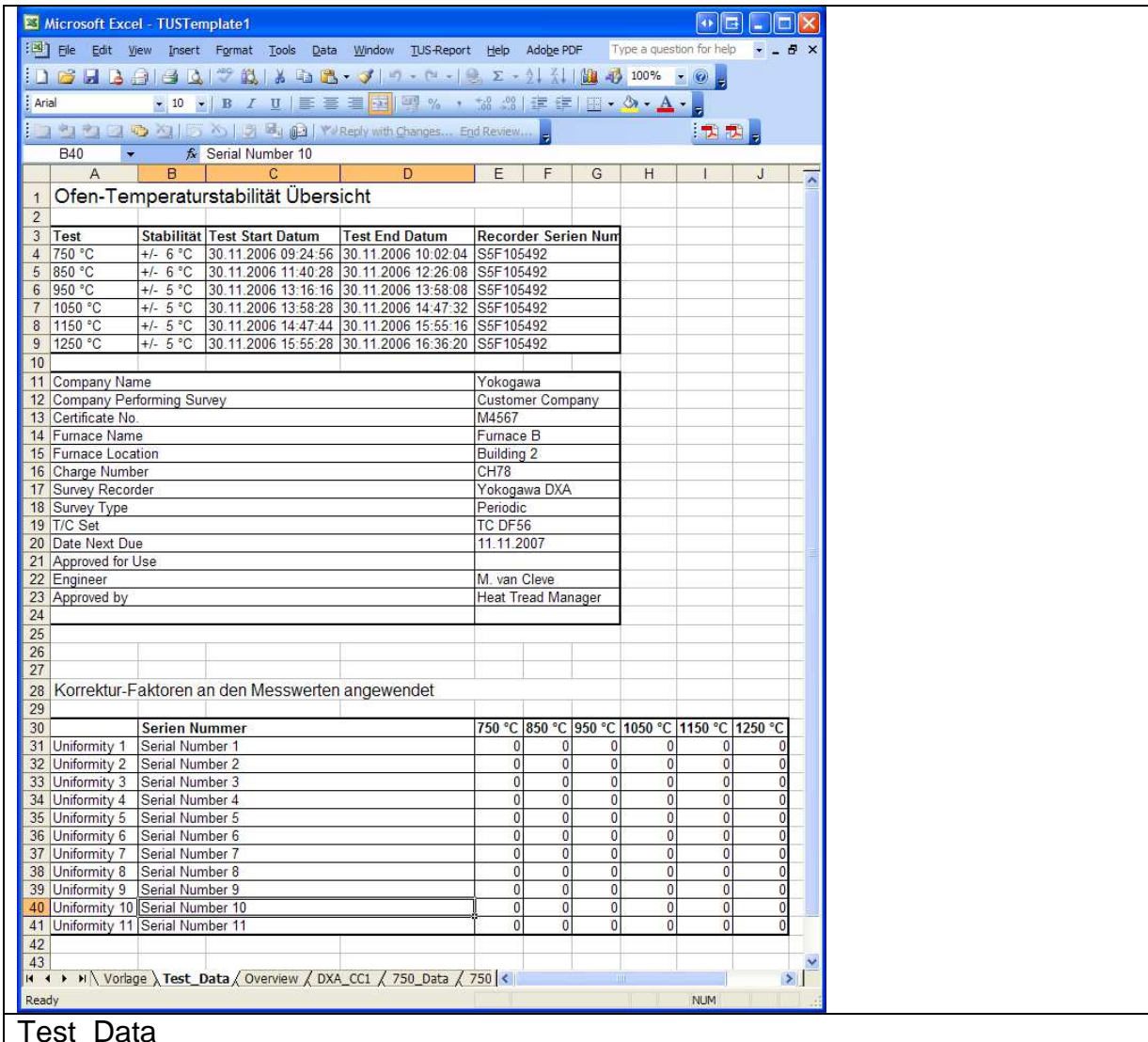

The screenshot shows a Microsoft Excel spreadsheet titled "TUS-Report". The main data is organized into two tables. The first table, "Ofen-Temperaturstabilität Übersicht", lists test parameters for 10 different temperatures. The second table, "Korrektur-Faktoren an den Messwerten angewendet", shows uniformity factors for 11 serial numbers across six temperatures.

Test	Stabilität	Test Start Datum	Test End Datum	Recorder	Serien Num
750 °C	+/- 6 °C	30.11.2006 09:24:56	30.11.2006 10:02:04	S5F105492	
850 °C	+/- 6 °C	30.11.2006 11:40:28	30.11.2006 12:26:08	S5F105492	
950 °C	+/- 5 °C	30.11.2006 13:16:16	30.11.2006 13:58:08	S5F105492	
1050 °C	+/- 5 °C	30.11.2006 13:58:28	30.11.2006 14:47:32	S5F105492	
1150 °C	+/- 5 °C	30.11.2006 14:47:44	30.11.2006 15:55:16	S5F105492	
1250 °C	+/- 5 °C	30.11.2006 15:55:28	30.11.2006 16:36:20	S5F105492	

	Serien Nummer	750 °C	850 °C	950 °C	1050 °C	1150 °C	1250 °C
Uniformity 1	Serial Number 1	0	0	0	0	0	0
Uniformity 2	Serial Number 2	0	0	0	0	0	0
Uniformity 3	Serial Number 3	0	0	0	0	0	0
Uniformity 4	Serial Number 4	0	0	0	0	0	0
Uniformity 5	Serial Number 5	0	0	0	0	0	0
Uniformity 6	Serial Number 6	0	0	0	0	0	0
Uniformity 7	Serial Number 7	0	0	0	0	0	0
Uniformity 8	Serial Number 8	0	0	0	0	0	0
Uniformity 9	Serial Number 9	0	0	0	0	0	0
Uniformity 10	Serial Number 10	0	0	0	0	0	0
Uniformity 11	Serial Number 11	0	0	0	0	0	0

The calculation results will be displayed on the overview page.

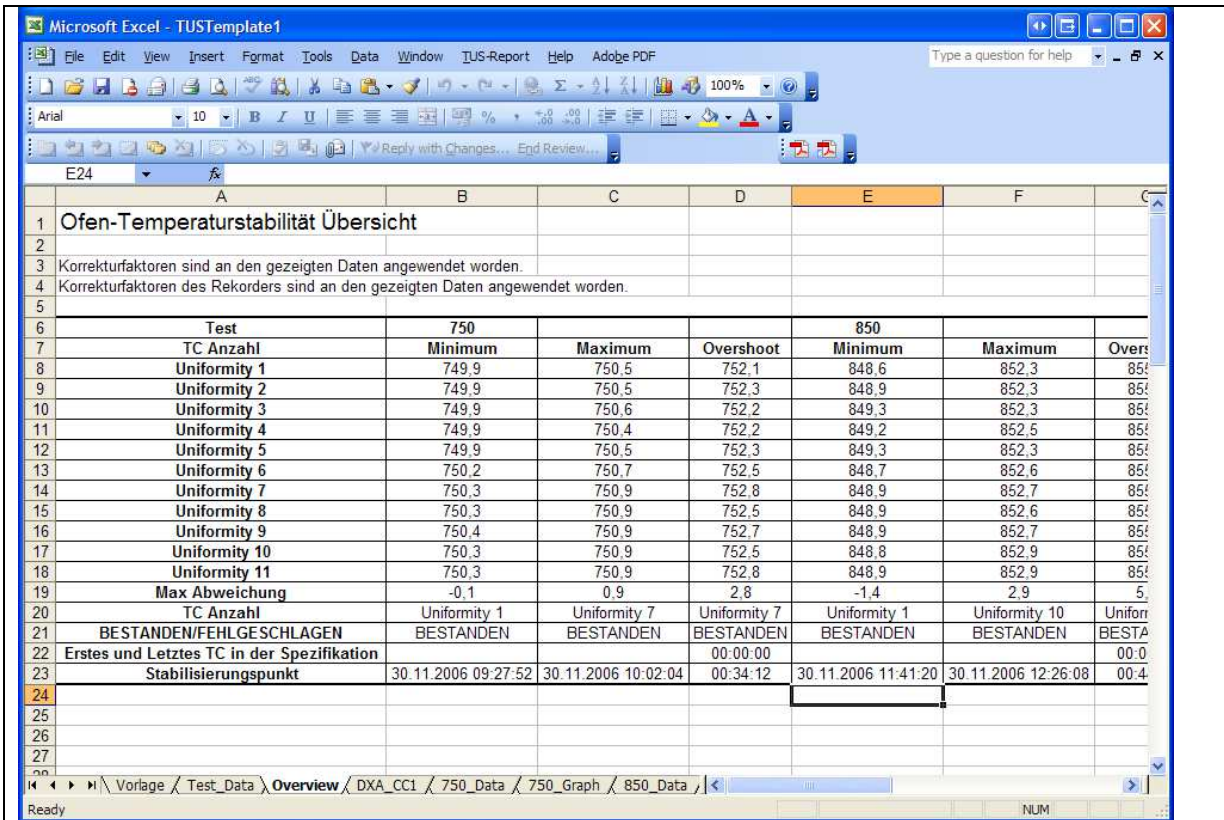

The screenshot shows an Excel spreadsheet titled 'TUSTemplate1' with the following data:

Test	750			850		
TC Anzahl	Minimum	Maximum	Overshoot	Minimum	Maximum	Over
Uniformity 1	749.9	750.5	752.1	848.6	852.3	852.3
Uniformity 2	749.9	750.5	752.3	848.9	852.3	852.3
Uniformity 3	749.9	750.6	752.2	849.3	852.3	852.3
Uniformity 4	749.9	750.4	752.2	849.2	852.5	852.5
Uniformity 5	749.9	750.5	752.3	849.3	852.3	852.3
Uniformity 6	750.2	750.7	752.5	848.7	852.6	852.6
Uniformity 7	750.3	750.9	752.8	848.9	852.7	852.7
Uniformity 8	750.3	750.9	752.5	848.9	852.6	852.6
Uniformity 9	750.4	750.9	752.7	848.9	852.7	852.7
Uniformity 10	750.3	750.9	752.5	848.8	852.9	852.9
Uniformity 11	750.3	750.9	752.8	848.9	852.9	852.9
Max Abweichung	-0.1	0.9	2.8	-1.4	2.9	5.0
TC Anzahl	Uniformity 1	Uniformity 7	Uniformity 7	Uniformity 1	Uniformity 10	Uniformity 10
BESTANDEN/FEHLGESCHLAGEN	BESTANDEN	BESTANDEN	BESTANDEN	BESTANDEN	BESTANDEN	BESTANDEN
Erstes und Letztes TC in der Spezifikation			00:00:00			00:00:00
Stabilisierungspunkt	30.11.2006 09:27:52	30.11.2006 10:02:04	00:34:12	30.11.2006 11:41:20	30.11.2006 12:26:08	00:40:00

Overview

Data for the CC1 Option are displayed on the sheet DXA_CC1.

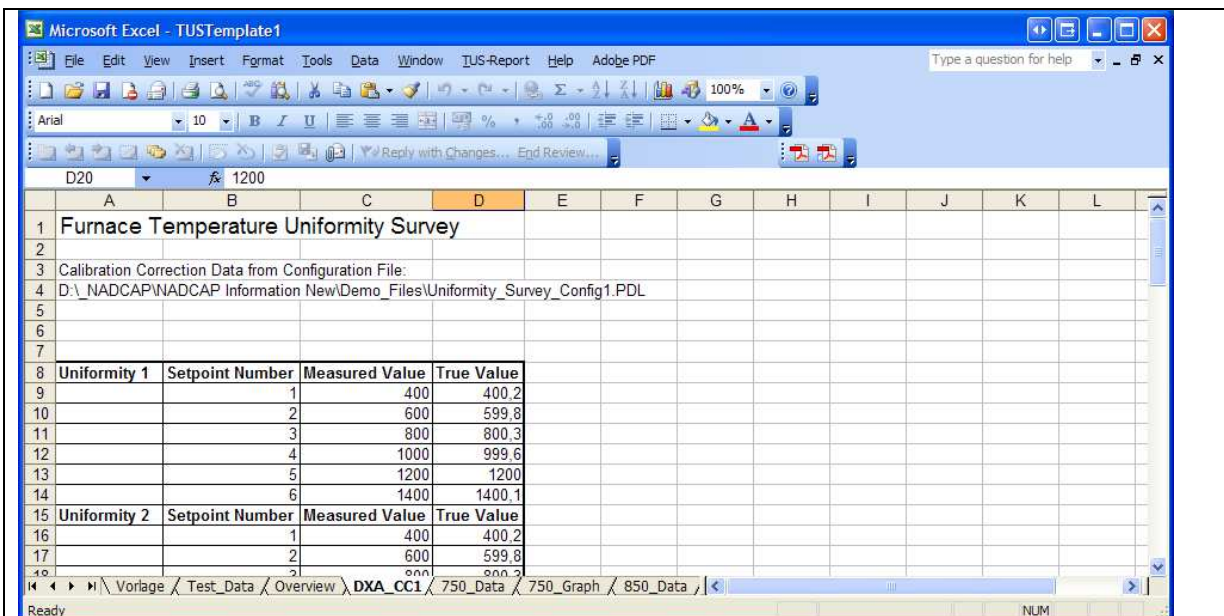

The screenshot shows an Excel spreadsheet titled 'TUSTemplate1' with the following data:

Uniformity	Setpoint Number	Measured Value	True Value
Uniformity 1	1	400	400.2
Uniformity 1	2	600	599.8
Uniformity 1	3	800	800.3
Uniformity 1	4	1000	999.6
Uniformity 1	5	1200	1200
Uniformity 1	6	1400	1400.1
Uniformity 2	1	400	400.2
Uniformity 2	2	600	599.8
Uniformity 2	3	800	800.3
Uniformity 2	4	1000	999.6
Uniformity 2	5	1200	1200
Uniformity 2	6	1400	1400.1

DXA_CC1

A tabular and graphic representation of all readings of the respective data files is portrayed on the following pages.

The screenshot shows an Excel spreadsheet with the following data table:

	MAX	Uniformity 1	Uniformity 1MAX	Uniformity 2	Uniformity 2MAX	Uniformity 3	Uniformity 3MAX	Uniformity 4	Uniformity 4MAX
7	Datum	Zeit							
8	30.11.2006	09:24:56	106.0	106.0	105.9	105.9	105.8	105.8	105.9
9	30.11.2006	09:25:24	231.3	270.6	231.1	270.6	231.2	270.7	231.0
10	30.11.2006	09:25:52	448.6	478.2	448.7	478.2	448.6	478.2	448.6
11	30.11.2006	09:26:20	587.4	607.3	587.4	607.4	587.4	607.3	587.4
12	30.11.2006	09:26:48	667.4	687.3	667.6	687.2	677.3	687.4	677.2
13	30.11.2006	09:27:16	731.0	735.0	731.1	735.0	731.2	736.2	731.1
14	30.11.2006	09:27:44	746.1	748.0	746.2	748.2	746.2	748.2	746.4
15	30.11.2006	09:27:52	750.0	752.1	750.1	752.3	750.2	752.2	750.2
16	30.11.2006	09:27:56	750.2	752.1	750.1	752.3	750.0	752.2	750.0
17	30.11.2006	09:28:12	750.0	750.2	750.0	750.3	750.1	750.2	749.9
18	30.11.2006	09:28:40	750.1	750.2	750.0	750.1	750.0	750.0	750.1

Tabular data display

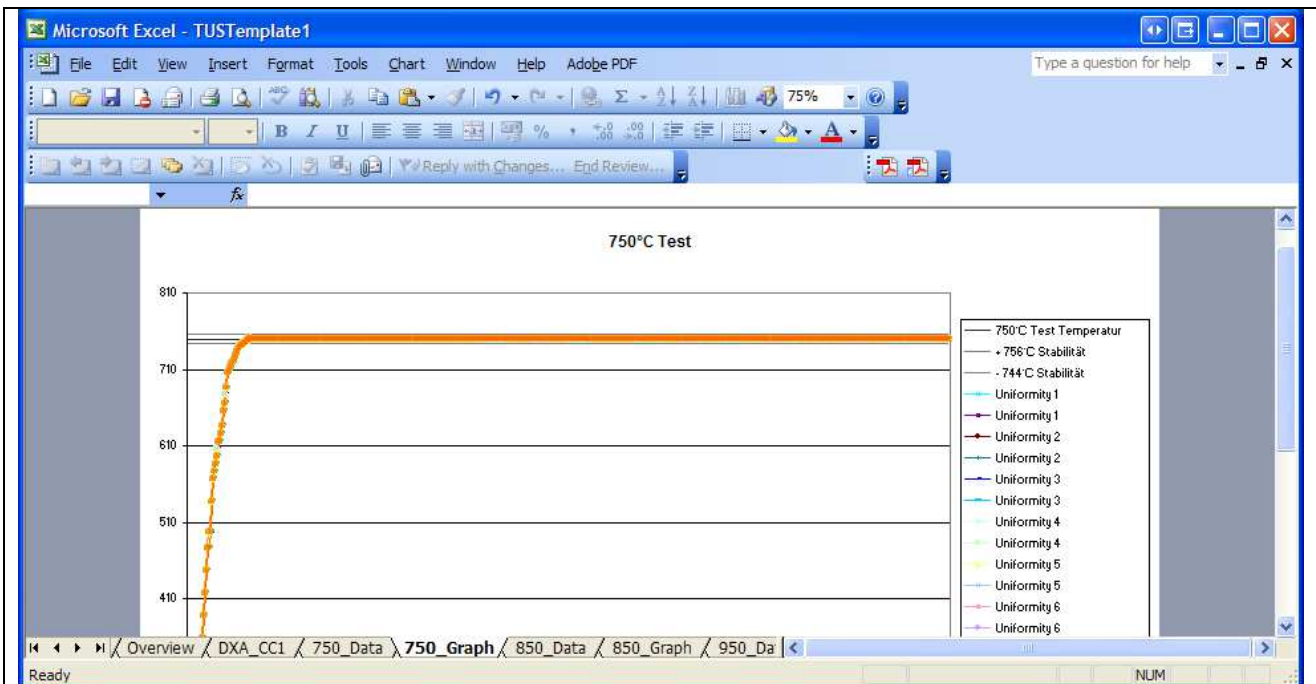

Graphic data display

7. Print Report

The program includes a print function which will print the complete report with all pages and sequential page numbering.

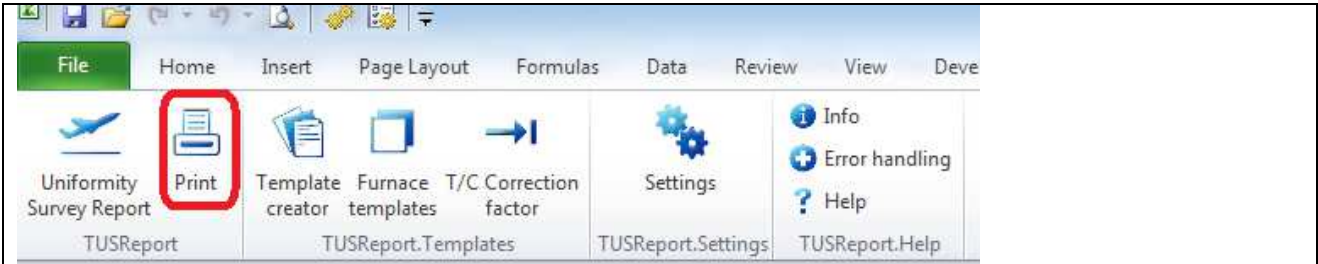

Menu list with „Print“ option

After clicking the „Print“ option, the „print preview“ with the appropriate test protocol pages will be shown. It is possible to then either select a printer, or to save the test as a .PDF file. A PDF printer is required for this.

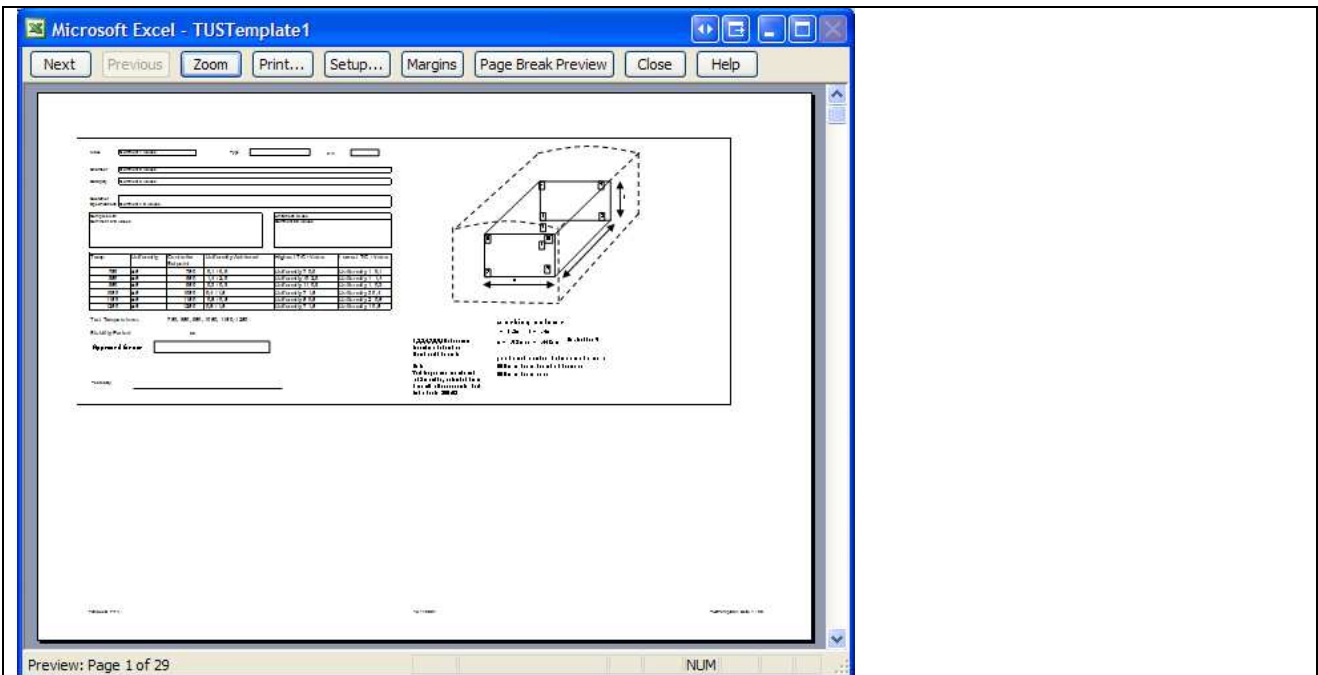

Print preview

8. Generating Excel templates

Through the report-function Excel Template it is possible to use all functions of MS Excel. For simple generation of the templates there is a "Template assistant".

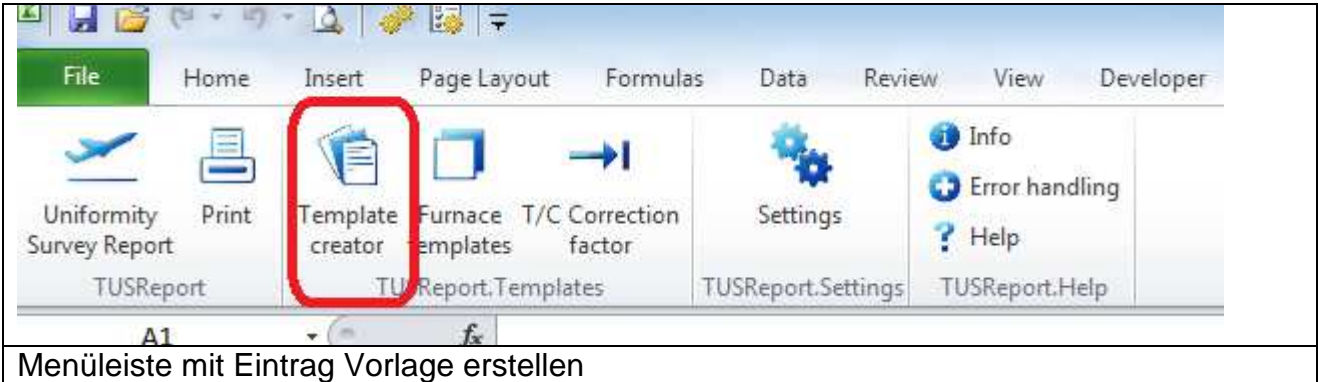

8.1 Creating a template

Having clicked on "Template creator" there will be a window shown with the device information.

In this window, all information relating to the specific recorder data is listed.

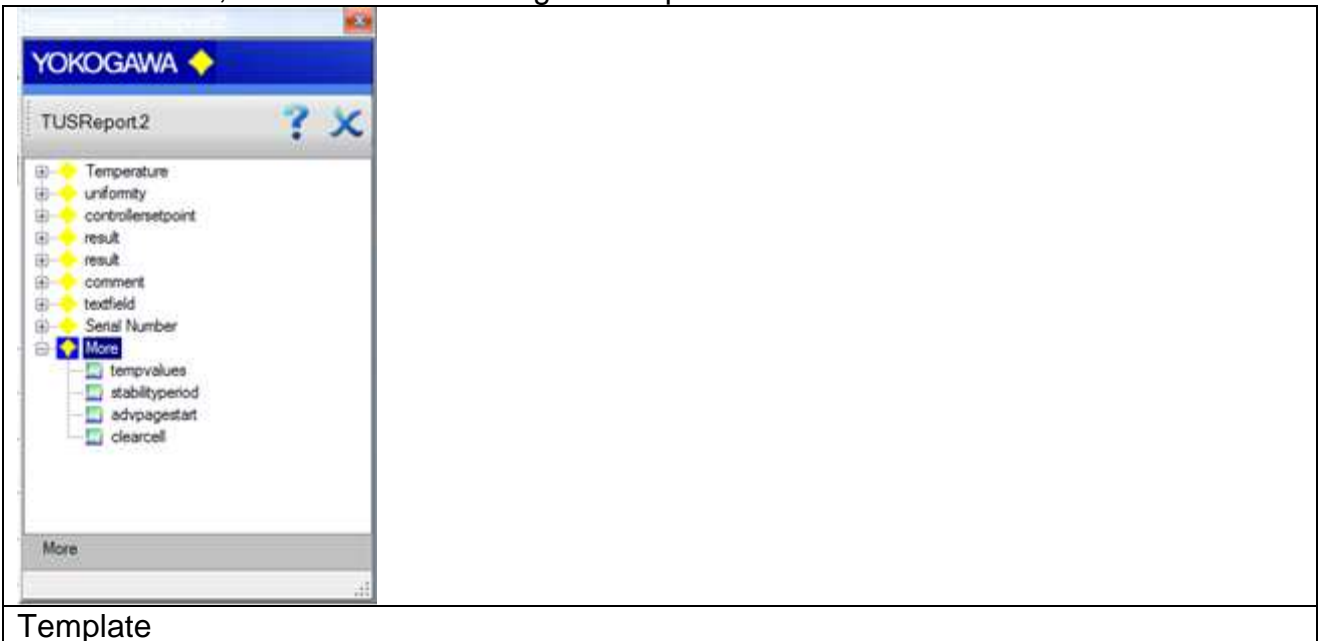

With the Drag & Drop functionality, you can add information to the Excel sheet.

Drag & Drop

The entry is indicated by a small triangle in the upper right hand corner. Clicking on this triangle will highlight the field.

The first two sheets of a template-file are supported.



Note:

Each value can be used only once per sheet!

The template can be saved and used in Excel Default File format or as Excel template format.

8.2 Custom design template header/footer

It is also possible to create a separate sheet for the automatically generated report sheet.

Create a template file with the following separate sheets.

Name the sheets:

- TEST_DATA → the report sheet with the test data
- OVERVIEW → the report sheet with the result overview
- _DATA → the report sheet with the temperature values, e.g. 750_DATA

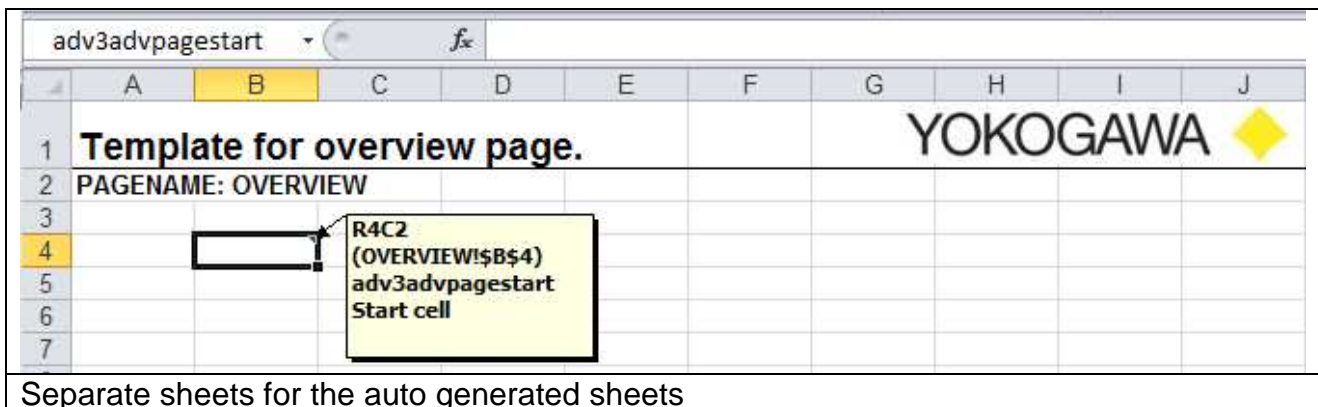

To put the report on the different place like the cell 'A1' (default) use the cellname "advpagestart". You will find this placeholder in the template creator.

Also it is possible to put every other information from the template creator on every sheet in the report.

8.3 Example data

After the installation of the software, some example templates are made available in the installation menu.

9. Info

In the “Help” dialogue box, the version number and the address are shown in case of questions or support issues.

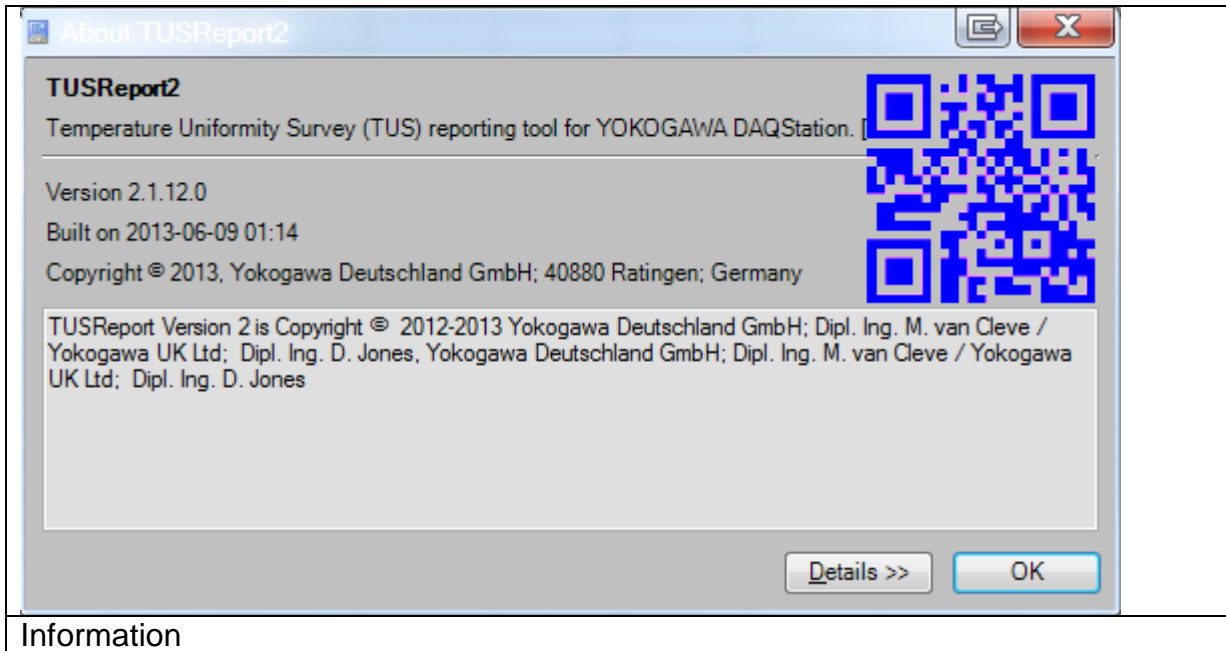

Load the latest version of our solution from the following web Page:

<http://www.AdvancedTools.de>

Check there for “Version 2” and “TUSReport Version 2”.

10. Error handling

If an error is recognized in the conversion or in general running of the program, this is indicated by an “Alert window” and registered in the error log.



Note:

1. Please read this chapter to solve the problem.
2. Use the Error Handling routine before calling your Services Team.

10.1 Solve Problem by yourself

“I installed my Office solution (VSTO add-in) successfully but when I open the Office application, my add-in does not load. What is the problem?”

This is a common question which I came across many times in Forums. Here are simple and quick checks that you can do before you start scratching your head or jump to the Forums. I’ll be using Excel as the Office application, but the approach is applicable to others more or less.

10.1.1 Check out “COM Add-Ins” dialog in Excel

Now open Excel and see if your add-in loads successfully. If not, open Excel Options dialog (File->Options) and navigate to Add-Ins tab.

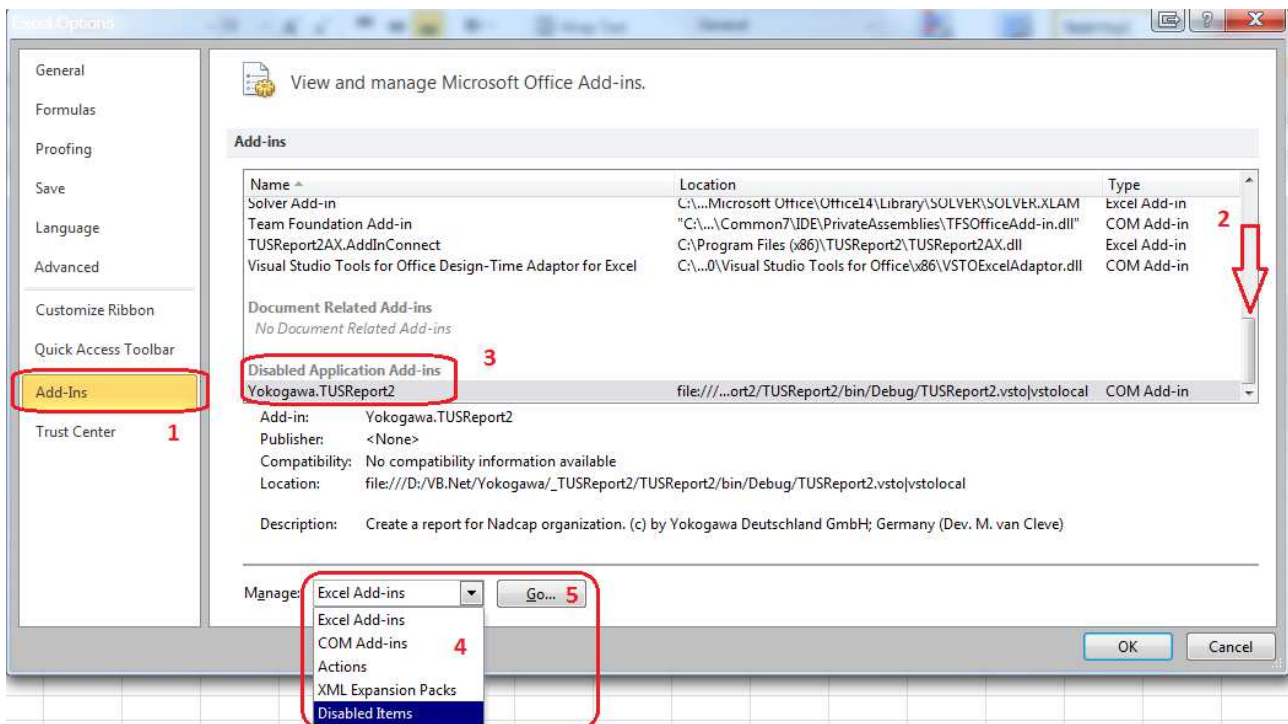

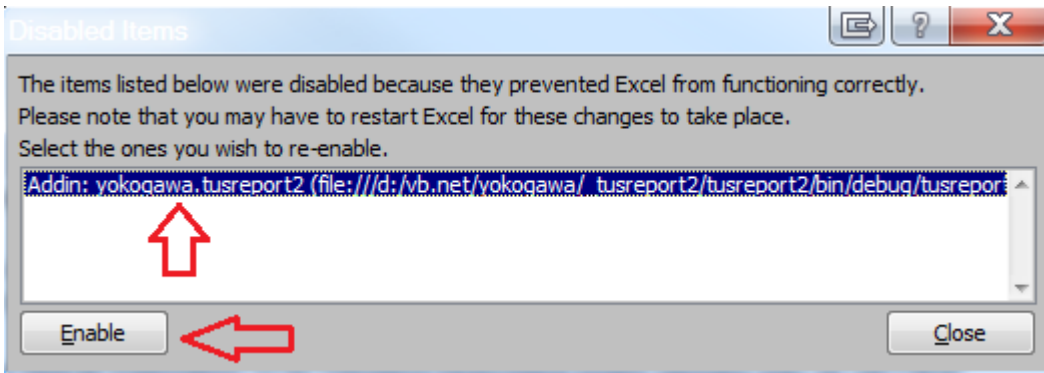

“Healthy add-ins” show up as “Active Application Add-ins”, however, if an add-in is disabled for whatever reason, it will appear under the “Inactive Application Add-ins”. You can select the “COM Add-ins” from the Manage dropdown at the bottom of this dialog and see the LoadBehavior of all COM add-ins. In normal cases, the add-in should be checked and its "Load Behavior" should be “Loaded at Startup”:

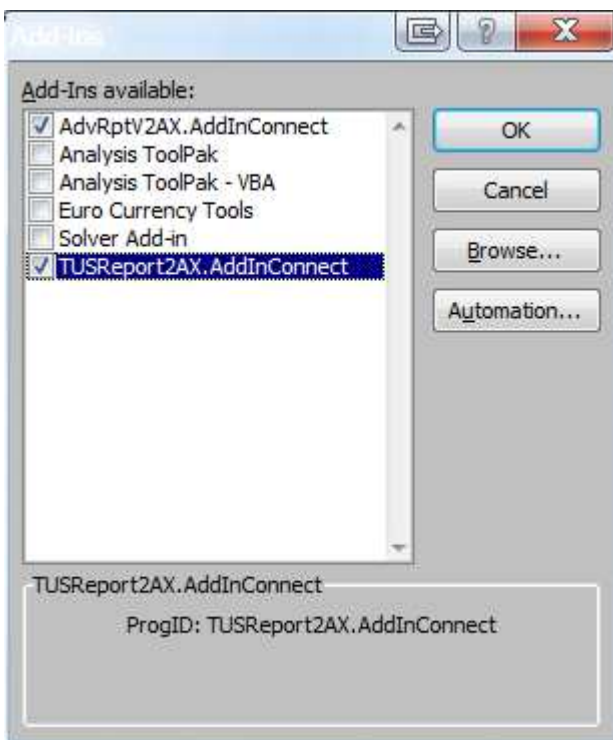
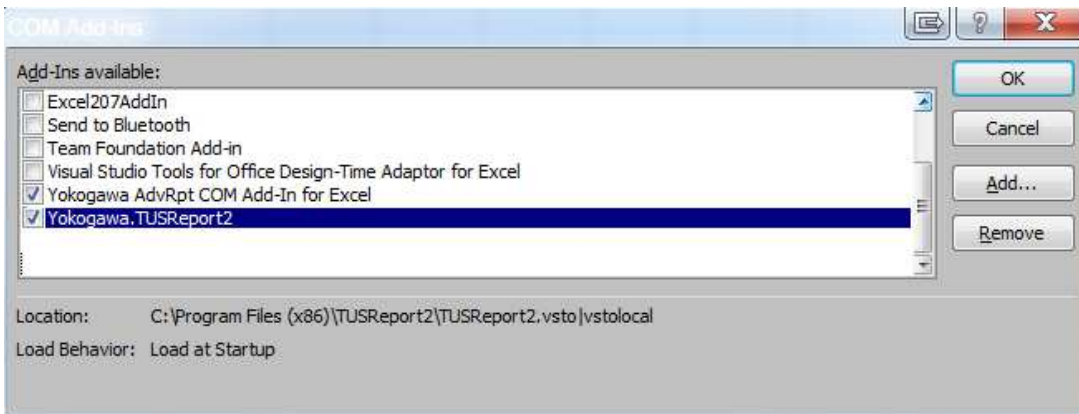

If the VSTO runtime encounters a problem loading the add-in, you'll see this message instead.

"Load Behavior: Not Loaded. A runtime error occurred during the loading of the COM Add-in".

10.1.2 Find the problem

Set the "VSTO_SUPPRESSDISPLAYALERTS" environment variable to 0. Then go back to the registry key I mentioned in step 1 and set the LoadBehavior to 3. Now restart the Excel. You should be able to see a dialog describing what is happening:

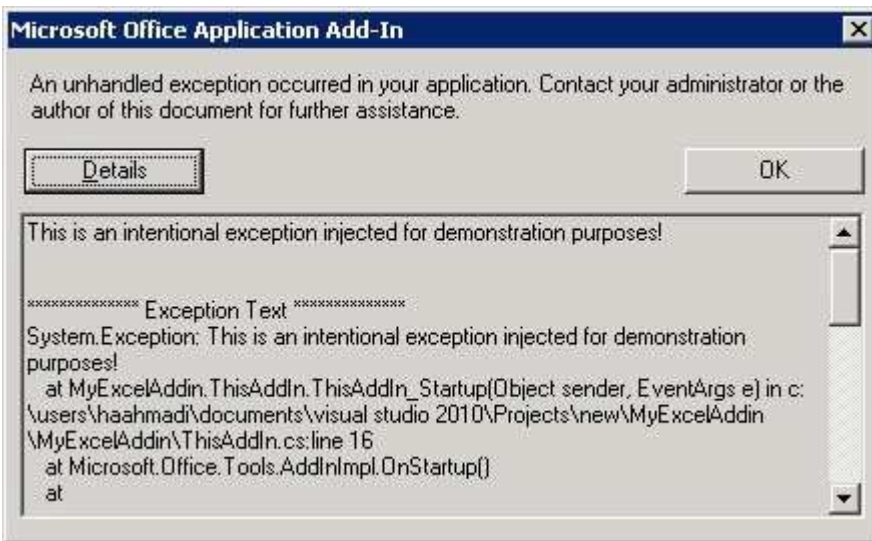

It is also a good practice to enclose the code inside the add-in's startup event in a try-catch block and log all exceptions.

10.1.3 Make sure your add-in is installed correctly and it is enabled

Open registry editor and navigate to "[HKEY_CURRENT_USER\Software\Microsoft\Office\Excel\Addins](#)". Here is how this registry key looks like after I installed MyExcelAddin:

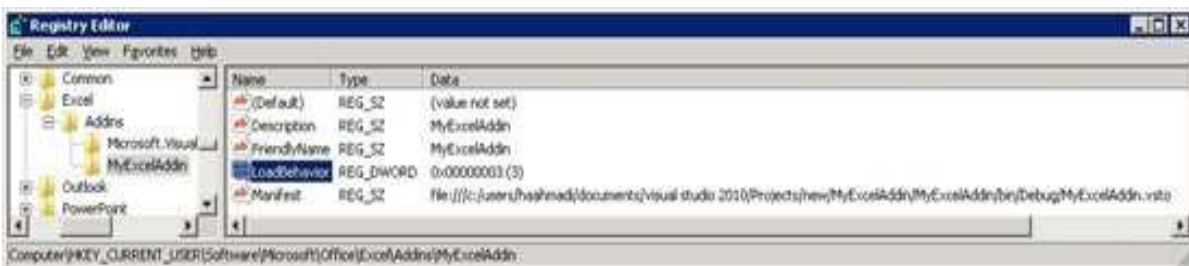

The registry string we are interested in the most is the LoadBehavior. Whenever you see "3" (Loaded at Startup) as the value of this string you are good in this part and your add-in tries to load when the Excel starts. For more information about registry entries for application-level Office solutions see [this article](#) on Microsoft site.

<http://msdn.microsoft.com/en-us/library/bb386106.aspx>

10.2 Before ask your Service Team

To solve the problem please use the Error handling routine under <Error Handling>. We need these information to check and solve a problem.

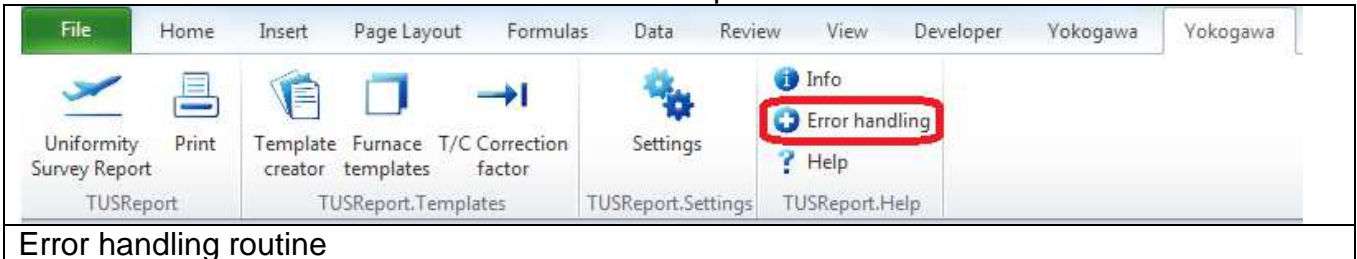

Error handling routine

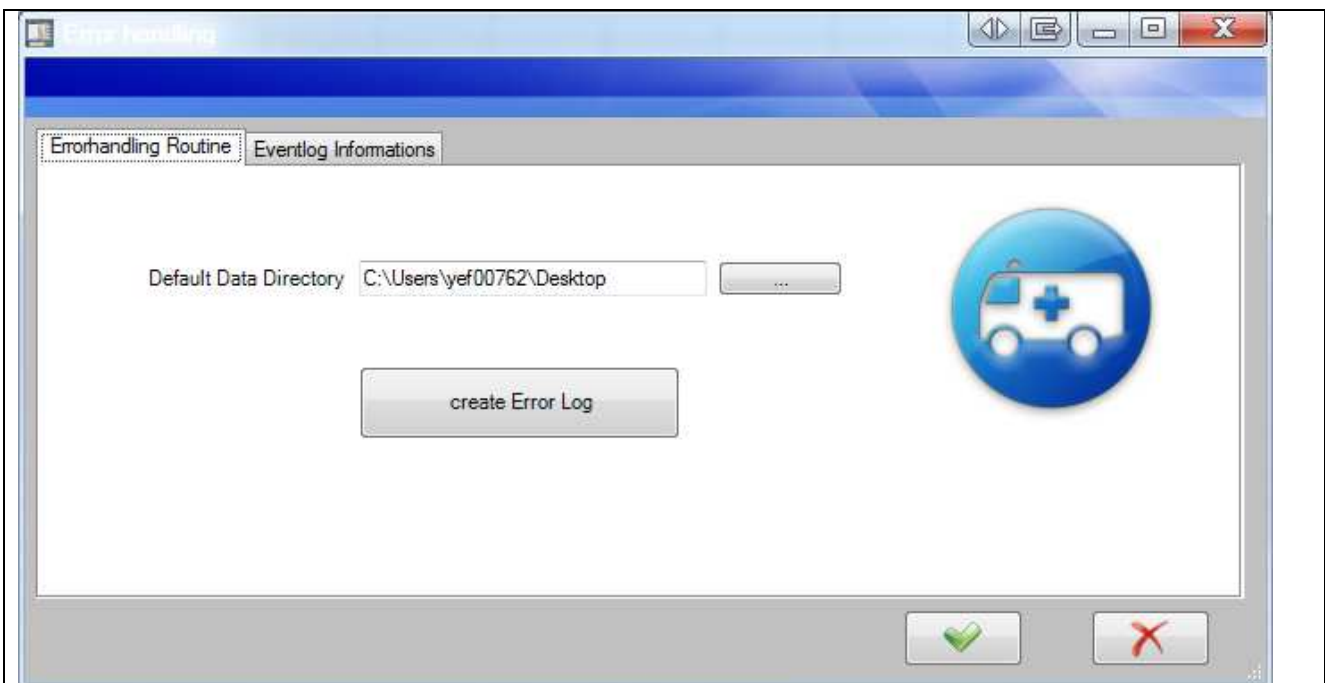

Menu Error handling routine



Log file saved

The Windows Explorer will be open.

Please send the files with exact error message and if necessary the file to be converted to the normal service email address shown in the program.

< End of Document >