



Installation and Operation of Flex-Flo

Model 220, 300, 350, 500 and HR

Installation and Owner's Manual

PNEG-914

Date: 02-04-11



BY THE
GSI GROUP



PNEG-914

Contents

Chapter 1 Safety	5
Safety Guidelines	5
General Safety Statement	6
Chapter 2 Decals	8
Chapter 3 Introduction	10
Applications	10
Background	10
Building Safety	10
Installation Sequence	10
Chapter 4 Flex-Flo Specifications (English/Metric)	11
The Feed Tank Connections	11
Chapter 5 Installation	15
Boot and Transfer Plate Installation	15
Slide Gate Installation	16
Inspection/Clean-Out Plate Installation	17
Restrictor Adjustment	18
Straight-Through Tandem Installation	19
Auger Tubing	20
Cementing Procedure	22
Outlet Holes	22
Drop Kit Installation	23
Kwik-Attach Drop Kit Installation	24
Power Unit and Control Unit	25
Auger	28
Auger Installation	28
Extension Hopper Installation	30
Operation Guidelines	32
Chapter 6 Parts List	35
Flex-Flo Feed Line Components	36
Direct Drive Power Unit Assemblies	37
Model 220 Unloader and Anchor Assembly	40
Model 300, 350 and HR Unloader and Anchor Assembly	41
Model 500 Unloader and Anchor Assembly	42
Direct Drive and Tube Anchor	43
Belt Drive and Tube Anchor	44
Model 220, 300 and 350 Control Unit (FLX-4496)	46
Flex-Flo Control Unit (FLX-5015)	48
Belt Drive Power Unit	50
Direct Drive Power Unit	51
Drop Kit/Kwik-Attach Drop Kit	52
Unloader Switch	53
Micro Drop Tube Switch/Proximity Switch	54

Table of Contents

Chapter 7	Wiring Diagrams	55
	FLX-4496 or FLX-5015 Factory Wiring Diagram	55
	Wiring Diagram for Extension Flex-Flo Using Smart-Flex Control	56
	Wiring Diagram for Extension Flex-Flo Using Two (2) FLX-4496 Controls	57
	Flex-Flo Control with 220 Volt 24 Hour Time Clock	58
	Flex-Flo Control with Proximity Switch (AP-1002)	59
	Flex-Flo Control with Proximity Switch (AP-2983)	60
	Flex-Flo Control with Drop Tube Switch or Hopper Level Switch	61
	Flex-Flo Control with Smart IR Sensor (FLX-4951)	62
Chapter 8	Warranty	63

Safety Guidelines

This manual contains information that is important for you, the owner/operator, to know and understand. This information relates to protecting **personal safety** and **preventing equipment problems**. It is the responsibility of the owner/operator to inform anyone operating or working in the area of this equipment of these safety guidelines. To help you recognize this information, we use the symbols that are defined below. Please read the manual and pay attention to these sections. Failure to read this manual and its safety instructions is a misuse of the equipment and may lead to serious injury or death.



This is the safety alert symbol. It is used to alert you to potential personal injury hazards. Obey all safety messages that follow this symbol to avoid possible injury or death.



DANGER indicates a hazardous situation which, if not avoided, will result in death or serious injury.



WARNING indicates a hazardous situation which, if not avoided, could result in death or serious injury.



CAUTION, used with the safety alert symbol, indicates a hazardous situation which, if not avoided, could result in minor or moderate injury.



NOTICE is used to address practices not related to personal injury.

1. Safety

General Safety Statement

Our foremost concern is your safety and the safety of others associated with grain handling equipment. This manual is to help you understand safe operating procedures and some problems which may be encountered by the operator and other personnel.

As owner and/or operator, you are responsible to know what requirements, hazards and precautions exist and inform all personnel associated with the equipment or in the area. Safety precautions may be required from the personnel. Avoid any alterations to the equipment, which may produce a very dangerous situation, where SERIOUS INJURY or DEATH may occur.

Electrical Safety

An adequate and safe power supply to the Flex-Flo System unit is essential for safety. A competent and qualified electrician must undertake all electrical wiring. All wiring is to be installed in accordance with all local and National Standards and Regulations relevant to your country and region.

Electrical safety devices, emergency stops and main isolators are recommended with the Flex-Flo System and are essential for safety. This should be installed as indicated in the enclosed installation instructions and in accordance with the relevant codes and directives.

User's Manual

This manual contains information and instructions essential to the safe installation and use of the Flex-Flo System. Read this manual thoroughly **before** attempting any installation or use of the Flex-Flo System. Keep this manual with the Flex-Flo System or in a location where it can be readily accessed. Failure to read this manual and its safety instructions is a misuse of the equipment.

Correct Uses of the Flex-Flo System

The Flex-Flo System is designed for the sole purpose of conveying granular or powdered agricultural animal feed. Use of the system in any other way is a misuse of the system and may endanger the health and safety.

Only genuine AP/Cumberland parts are to be used in the installation and use of the Flex-Flo System. Use of other non-genuine parts is a misuse of the system and may lead to dangerous situations imperilling the safety and health of you and others.

This system is not designed for use in atmospheres where there is a risk of explosion. Use in such an environment is prohibited. If in doubt contact your dealer or the GSI group.

Safety Guards

The Flex-Flo System contains many moving and electrical parts, which will cause serious injury or death if touched. Guards are placed on the machine to protect you. Operating the machine at any time with guards removed or incorrectly fitted is a serious misuse of the machine and endangers safety.

Safety in Handling the Flex-Flo System

The Flex-Flo drive unit weighs 48 lbs. (22 kgs). All precautions should be taken when lifting and or moving the unit. Ideally mechanical lift equipment should be used. If manual handling is necessary assistance should be sought from other people.

CE Compliance

In accordance with European Union Directives, GSI has made every effort to ensure that this product complies with the essential requirements of the machinery directive, the low voltage directive and the electromagnetic compatibility directive. As such, we have declared conformity and affixed the CE mark. Our declaration relates only to genuine GSI Flex-Flo Systems installed as intended by GSI. We cannot and do not declare conformity for any modifications, additions or any systems whatsoever operating on or with GSI products that are not supplied by GSI or are in any way outside the control of GSI.

Safety in Maintenance

The Flex-Flo System is designed to keep maintenance to a minimum, however, some repairs will be necessary in the course of the life of the system. Do not attempt any repairs on the system unless you are competent to do so. Remember that the Flex-Flo operates under automatic control and will start without warning. ***Never attempt any work on the Flex-Flo System without first isolating the drive unit from the main power and locking the isolator so that only you can turn the power back ON.*** Follow all guidelines given in the maintenance section of this manual.

Before restarting the Flex-Flo System, make sure that all electrical enclosures are locked closed and all guards and other safety measures are correctly fitted. If in any doubt, contact your dealer or the GSI group for assistance.

Dust

Under normal working conditions little or no dust should be created by the Flex-Flo System. However, some dust may be created, which may be harmful to your health if inhaled. To prevent this, wear a suitable type dust mask.

Noise

Noise is not generally a hazard associated with the Flex-Flo System. Excessive noise may indicate a problem with the machines. Tests on this machine indicate noise levels at a position one meter from the drive unit and 1.6 meters above the ground do not exceed 70 dBa, continuous "A" weighted sound pressure or 63 Pa, instantaneous "C" weighted sound pressure.

Sound Signs and Warnings

The following pages show you exactly where the safety and warning decals should be placed on the Flex-Flo System. If a decal is missing or unreadable, please contact your dealer or the GSI group, for a free replacement.

For guidance or assistance on any issues relating to the safe use of the Flex-Flo System,

Contact:

GSI Group

1004 E. Illinois St.
Assumption, IL. 62510
Phone: 1-217-226-4421

2. Decals

THE GSI GROUP



FLX-4512
ELECTRICAL BOX ASSEMBLY

CONTACT RATING: 1-1/2 HP @ 240 VAC MAX.,
25 FLA, 1 PHASE

COIL RATING: 208-240 VAC, 50/60 Hz.



⚠ DANGER
High Voltage.
Will cause injury
or death.
Lockout power
before servicing.

DC-1238

THE GSI GROUP



FLX-4512-3
ELECTRICAL BOX ASSEMBLY

CONTACT RATING: 1-1/2 HP @ 240 VAC MAX.,
25 FLA, 3 PHASE

COIL RATING: 280-240 VAC, 50/60 Hz.



⚠ DANGER
High Voltage.
Will cause injury
or death.
Lockout power
before servicing.

DC-1238-2-3

THE GSI GROUP



FLX-4511
ELECTRICAL BOX ASSEMBLY

CONTACT RATING: 1 HP @ 120 VAC MAX.,
25 FLA, 1 PHASE

COIL RATING: 120 VAC, 50/60 Hz.



⚠ DANGER
High Voltage.
Will cause injury
or death.
Lockout power
before servicing.

DC-1238



⚠ WARNING

ROTATING AUGER
can crush and dismember.

- Keep hands out of feed opening.
- Lockout power and secure auger before servicing.

DC-884

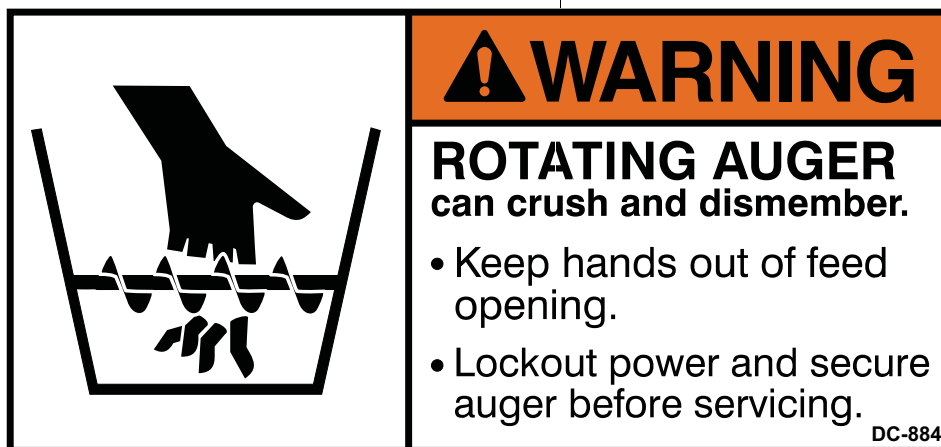

3. Introduction

Applications

In poultry application, Flex-Flo Fill System conveys feed from bulk feed tank to hoppers inside the poultry building as shown in [Figure 3A](#). Other feed systems (i.e. cycle plus, chain feeder etc.) take the feed from the hopper to the desired locations in the building. On this layout, hopper level switches may be placed in more than one hopper to assure that no hopper empties before the control unit hopper requires feed. (All switches must be wired in parallel so that any one switch can start the system.)

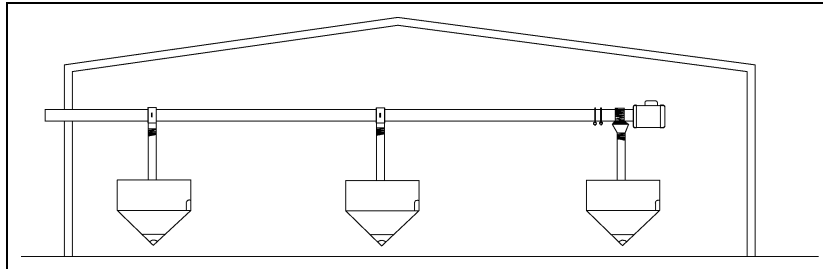

Figure 3A Poultry Application Layout

In swine applications, Flex-Flo Fill System conveys feed from bulk feed tanks to each individual feeder (i.e. S.S. hog feeder, drop feeder etc.) directly as shown in [Figure 3B](#). It is at this location that feed is being consumed. A feed level control is installed at the end to shut off the system after all feeders are filled.

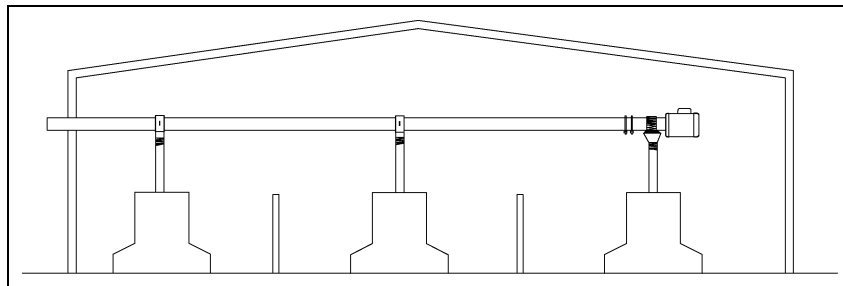

Figure 3B Swine Application Layout

Background

The Flex-Flo Fill System consists of a combination of PVC tubes and preformed PVC elbows. A special PVC cement is used to connect the tubes and elbows. The PVC tubes are available in four (4) different sizes. The PVC tube contains a rotating auger which conveys the feed to the different outlet holes. The auger is driven by a direct drive power unit or a belt drive power unit.

Building Safety

If you are intending to install the Flex-Flo System at high levels and/or suspended from a building structure, it is important that you check the structural integrity of the building to carry the additional load. For information on the imposed loads on the building by the Flex-Flo System, please contact the dealer or the GSI group.

Installation Sequence

This manual outlines the recommended order for the installation of the Flex-Flo System. Following this guideline will provide the safest and easiest method of installation. Above all, connection of the system to the electrical mains should be the final stage of installation. Failure to observe this could lead to a fatal accident.

4. Flex-Flo Specifications (English/Metric)

Flex-Flo Systems Specifications

	Model 220	Model 300	Model 350	Model 500	Model HR
Auger Tube Diameter	2.2" 55 mm	3" 75 mm	3-1/2" 90 mm	5" 125 mm	3-1/2" 90 mm
Carrying Capacity based on 40 lbs./cubic ft.	15 lbs./min 7 kg/min 900 lbs./hr 420 kg/hr	50 lbs./min 22 kg/min 3000 lbs./hr 1400 kg/hr	100 lbs./min 45 kg/min 6000 lbs./hr 2700 kg/hr	220 lbs./min 100 kg/min 13200 lbs./hr 6000 kg/hr	50 lbs./min 22 kg/min 3000 lbs./hr 1400 kg/hr
Maximum Particle Size and Feed Type	1/8" (3.175 mm) x 1/2" (12.7 mm) Long Maximum Moisture Content 18%	Crumble Type Feed Mash	Shelled Corn or Pellets 3/16" (4.76 mm) x 1/2" (12.7 mm) Ground Corn	Larger Feed Fragments Like Shelled Corn or Pellets 3/8" (9.52 mm) x 1" (25.4 mm) Long	High Moisture Shelled Corn (up to 27%) or Ground Feed. 3/8" (9.52 mm) Diameter x 3/4" (19.05 mm) Long

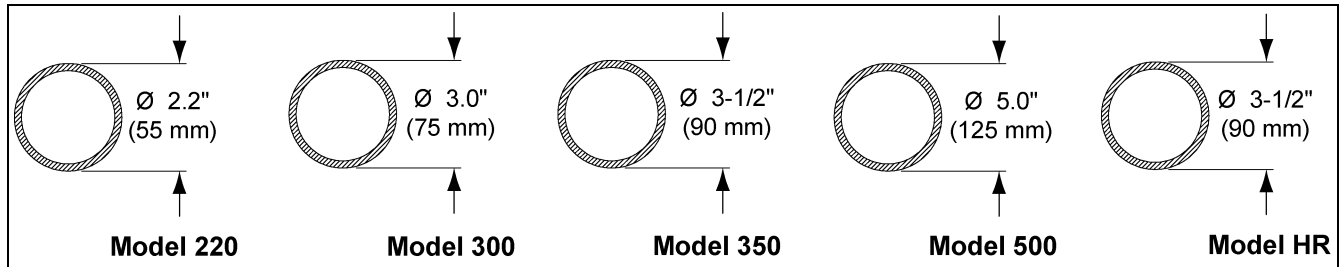

Figure 4A

The Feed Tank Connections

Feed Tank Orientation

Positioning the feed tank in line with the Flex-Flo System will provide the most trouble-free operation possible. Avoid unnecessary elbows and curves to ease system installation. A feed tank with a 30° unloader is generally required to be at least 10-1/2' (3.2 m) away from the building. With a straight unloader, the tank will be approximately 4' (1.22 m) farther away from the building in order to make auger tube connections. The reference points are based upon the height where the system enters the building. Different unloaders with various elbows and curves used provide different entrance opportunities. The distances are achieved by modifying and adjusting the elbows and tubing as needed. See tables [on Page 12](#) (English) or see tables [on Page 13](#) (Metric) for tank placement recommendations.



Figure 4B

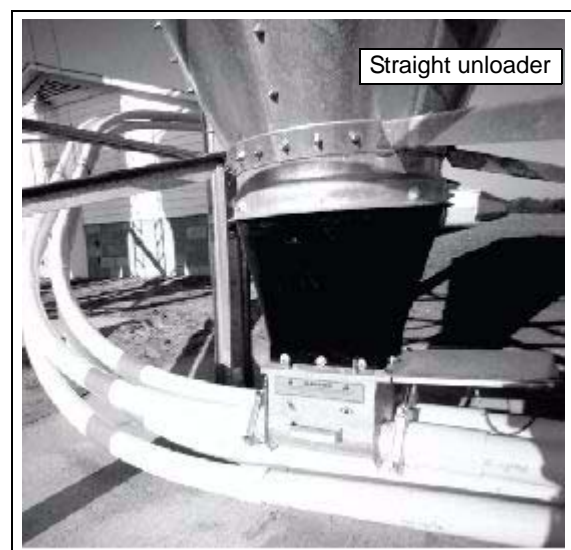

Figure 4C

4. Flex-Flo Specifications (English/Metric)

Tank Centerline to Building Entrance Distance “X” from Given Height “H” (English)

Model 220 with 10' Radius Elbows						
“H” (ft.)	“X” for 30° Boot (ft.)			“X” for Straight Boot (ft.)		
	30°	45°	60°	30°	45°	60°
5.0	10.5	-	-	15.0	-	-
6.0	12.5	11.0	-	17.0	-	-
7.0	14.0	12.0	-	18.5	17.0	-
8.0	16.0	13.0	-	20.0	18.0	-
9.0	17.5	14.0	-	22.0	19.0	-
10.0	19.5	15.0	-	23.5	20.0	-
11.0	21.0	16.0	14.5	25.5	21.0	19.5
12.0	23.0	17.0	15.0	27.0	22.0	20.0
13.0	24.5	18.0	16.0	29.0	23.0	21.0
14.0	26.5	19.0	16.5	30.5	24.0	21.5
15.0	28.0	20.0	17.0	32.5	25.0	22.0
16.0	30.0	21.0	17.5	34.0	26.0	22.5
17.0	31.5	22.0	18.0	36.0	27.0	23.0
18.0	33.5	23.0	18.5	37.5	28.0	23.5
19.0	35.0	24.0	19.5	39.5	29.0	24.0
20.0	37.0	25.0	20.0	41.0	30.0	25.0

Model 500 with 6' Radius Elbow						
“H” (ft.)	“X” for 30° Boot (ft.)			“X” for Straight Boot (ft.)		
	30°	45°	60°	30°	45°	60°
5.0	9.0	-	-	12.0	10.0	-
6.0	10.5	8.0	7.5	13.5	11.0	10.0
7.0	12.0	9.0	8.0	15.5	12.0	11.0
8.0	14.0	10.0	8.5	17.0	13.0	11.5
9.0	15.5	11.0	9.0	19.0	14.0	12.0
10.0	17.0	12.0	9.5	20.0	15.0	12.5
11.0	19.0	13.0	10.0	22.5	16.0	13.0
12.0	20.5	14.0	11.0	23.5	17.0	13.5
13.0	22.5	15.0	11.5	26.0	18.0	14.0
14.0	24.0	16.0	12.0	27.0	19.0	15.0
15.0	26.0	17.0	12.5	29.5	20.0	15.5
16.0	27.5	18.0	12.5	30.5	21.0	16.0
17.0	29.5	19.0	13.5	33.0	22.0	16.5
18.0	31.0	20.0	14.0	34.5	23.0	17.0
19.0	33.0	21.0	15.0	36.0	24.0	17.5
20.0	34.5	22.0	15.5	37.5	25.0	18.5

Model 220, 300, 350 and HR with 5' Radius Elbow						
“H” (ft.)	“X” for 30° Boot (ft.)			“X” for Straight Boot (ft.)		
	30°	45°	60°	30°	45°	60°
5.0	9.0	-	-	12.0	10.0	-
6.0	10.5	8.0	7.5	13.5	11.0	10.0
7.0	12.0	9.0	8.0	15.5	12.0	11.0
8.0	14.0	10.0	8.5	17.0	13.0	11.5
9.0	15.5	11.0	9.0	18.5	14.0	12.0
10.0	17.0	12.0	9.5	20.5	15.0	12.5
11.0	19.0	13.0	10.0	22.0	16.0	13.0
12.0	20.5	14.0	11.0	24.0	17.0	13.5
13.0	22.5	15.0	11.5	25.5	18.0	14.0
14.0	24.0	16.0	12.0	27.5	19.0	15.0
15.0	26.0	17.0	12.5	29.0	20.0	15.5
16.0	27.5	18.0	12.5	31.0	21.0	16.0
17.0	29.5	19.0	13.5	32.5	22.0	16.5
18.0	31.0	20.0	14.0	34.5	23.0	17.0
19.0	33.0	21.0	15.0	36.0	24.0	17.5
20.0	34.5	22.0	15.5	38.0	25.0	18.5

4. Flex-Flo Specifications (English/Metric)

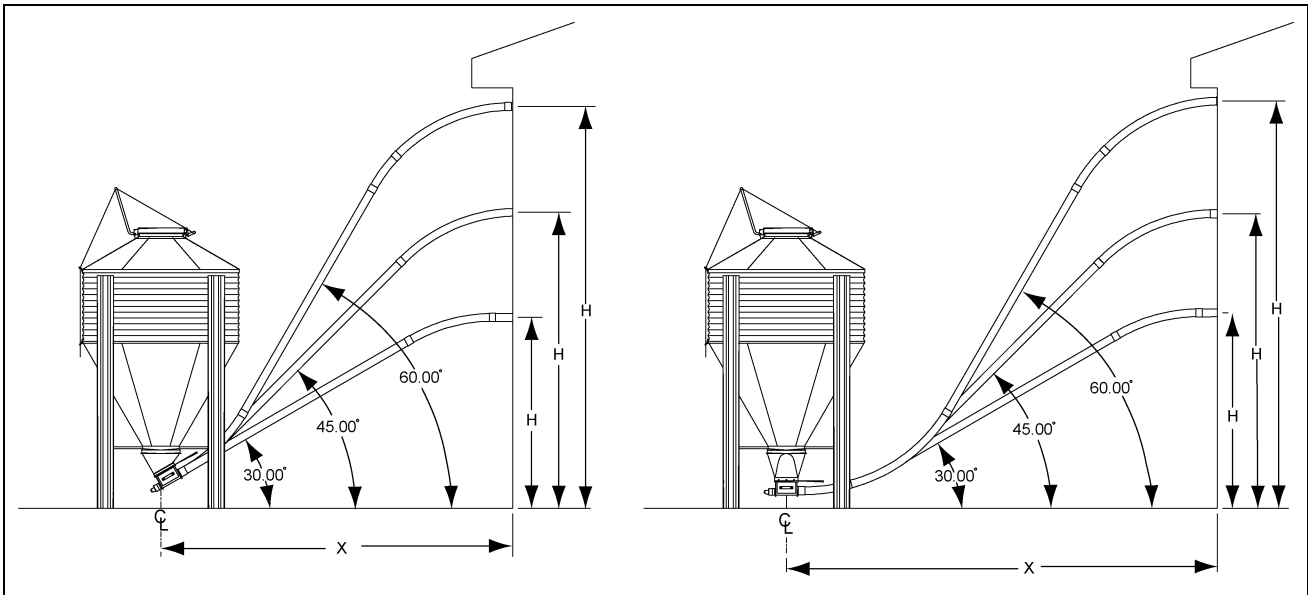

Figure 4D Equipment Orientation Charts

Tank Centerline to Building Entrance Distance “X” from Given Height “H” (Metric)

Model 220 with 10' Radius Elbows						
“H” (m)	“X” for 30° Boot (m)			“X” for Straight Boot (m)		
	30°	45°	60°	30°	45°	60°
1.52	3.20	-	-	4.57	-	-
1.83	3.81	3.35	-	5.18	-	-
2.13	4.27	3.66	-	5.64	5.18	-
2.44	4.88	3.96	-	6.10	5.49	-
2.74	5.33	4.27	-	6.71	5.79	-
3.05	5.94	4.57	-	7.16	6.10	-
3.35	6.40	4.88	4.42	7.77	6.40	5.94
3.66	7.01	5.18	4.57	8.23	6.71	6.10
3.96	7.47	5.49	4.88	8.84	7.01	6.40
4.27	8.08	5.79	5.03	9.30	7.32	6.55
4.57	8.53	6.10	5.18	9.91	7.62	6.71
4.88	9.14	6.40	5.33	10.36	7.92	6.86
5.18	9.60	6.71	5.49	10.97	8.23	7.01
5.49	10.21	7.01	5.64	11.43	8.53	7.16
5.79	10.67	7.32	5.94	12.04	8.84	7.32
6.10	11.28	7.62	6.10	12.50	9.14	7.62

Model 500 with 6' Radius Elbow						
“H” (m)	“X” for 30° Boot (m)			“X” for Straight Boot (m)		
	30°	45°	60°	30°	45°	60°
1.52	2.74	-	-	3.66	3.05	-
1.83	3.20	2.44	2.29	4.11	3.35	3.05
2.13	3.66	2.74	2.44	4.72	3.66	3.35
2.44	4.27	3.05	2.59	5.18	3.96	3.51
2.74	4.72	3.35	2.74	5.79	4.27	3.66
3.05	5.18	3.66	2.90	6.10	4.57	3.81
3.35	5.79	3.96	3.05	6.86	4.88	3.96
3.66	6.25	4.27	3.35	7.16	5.18	4.11
3.96	6.86	4.57	3.51	7.92	5.49	4.27
4.27	7.32	4.88	3.66	8.23	5.79	4.57
4.57	7.92	5.18	3.81	8.99	6.10	4.72
4.88	8.38	5.49	3.81	9.30	6.40	4.88
5.18	8.99	5.79	4.11	10.06	6.71	5.03
5.49	9.45	6.10	4.27	10.52	7.01	5.18
5.79	10.06	6.40	4.57	10.97	7.32	5.33
6.10	10.52	6.71	4.72	11.43	7.62	5.64

4. Flex-Flo Specifications (English/Metric)

Model 220, 300, 350 and HR with 5' Radius Elbow						
"H" (m)	"X" for 30° Boot (m)			"X" for Straight Boot (m)		
	30°	45°	60°	30°	45°	60°
1.52	2.74	-	-	3.66	3.05	-
1.83	3.20	2.44	2.29	4.11	3.35	3.05
2.13	3.66	2.74	2.44	4.72	3.66	3.35
2.44	4.27	3.05	2.59	5.18	3.96	3.51
2.74	4.72	3.35	2.74	5.64	4.27	3.66
3.05	5.18	3.66	2.90	6.25	4.57	3.81
3.35	5.79	3.96	3.05	6.71	4.88	3.96
3.66	6.25	4.27	3.35	7.32	5.18	4.11
3.96	6.86	4.57	3.51	7.77	5.49	4.27
4.27	7.32	4.88	3.66	8.38	5.79	4.57
4.57	7.92	5.18	3.81	8.84	6.10	4.72
4.88	8.38	5.49	3.81	9.45	6.40	4.88
5.18	8.99	5.79	4.11	9.91	6.71	5.03
5.49	9.45	6.10	4.27	10.52	7.01	5.18
5.79	10.06	6.40	4.57	10.97	7.32	5.33
6.10	10.52	6.71	4.72	11.58	7.62	5.64

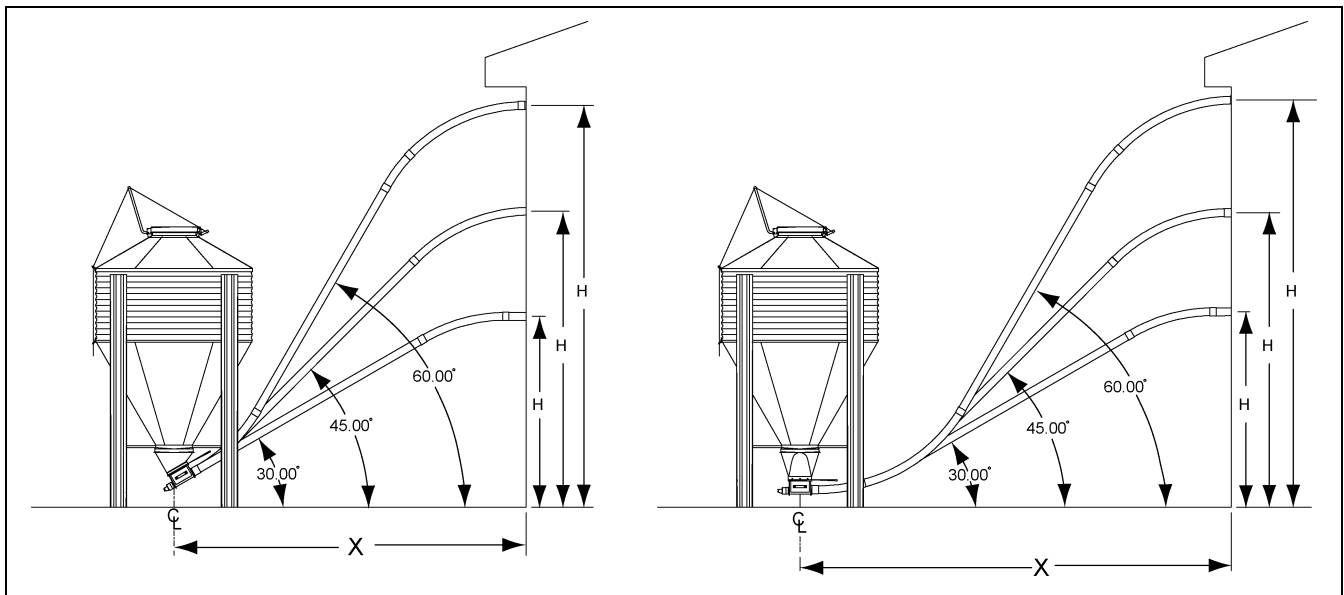

Figure 4E Equipment Orientation Charts



Improper installation methods of the hardware may cause permanent damage and possible breakage of the boot.

Boot and Transfer Plate Installation

NOTE: Installation of the boot is the same whether the tank has the standard collar or the Sure-Flo Feed Flow Control.

Slide the boot as far as possible into the tank collar or the Sure-Flo Feed Flow Control opening. (See Figure 5A.) Align the boot with the Flex-Flo System that will be installed. Using the holes in the collars for guides, drill eight (8) 11/32" holes into the boot rim. (See Figure 5B.)

Mount the boot to the collar with the hardware provided. Bolt the transfer plate and unloader braces to the boot as shown. See Figure 5C for proper usage and assembly direction of hardware for mounting the boot and the transfer plate. All connections should be tightened until they are "snug".

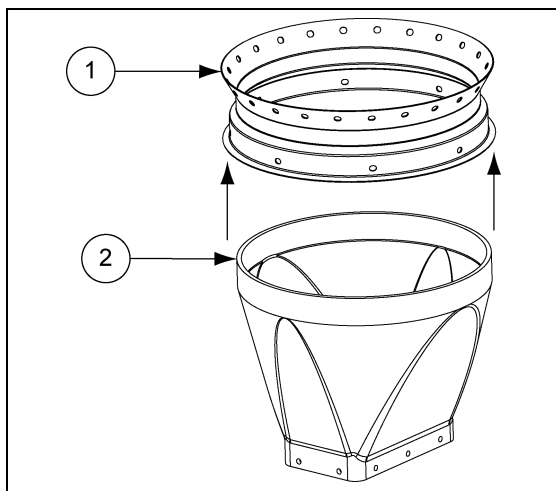

Figure 5A

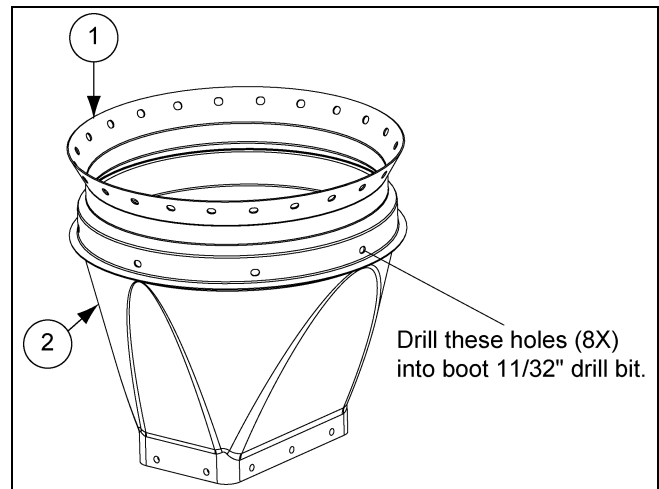

Figure 5B

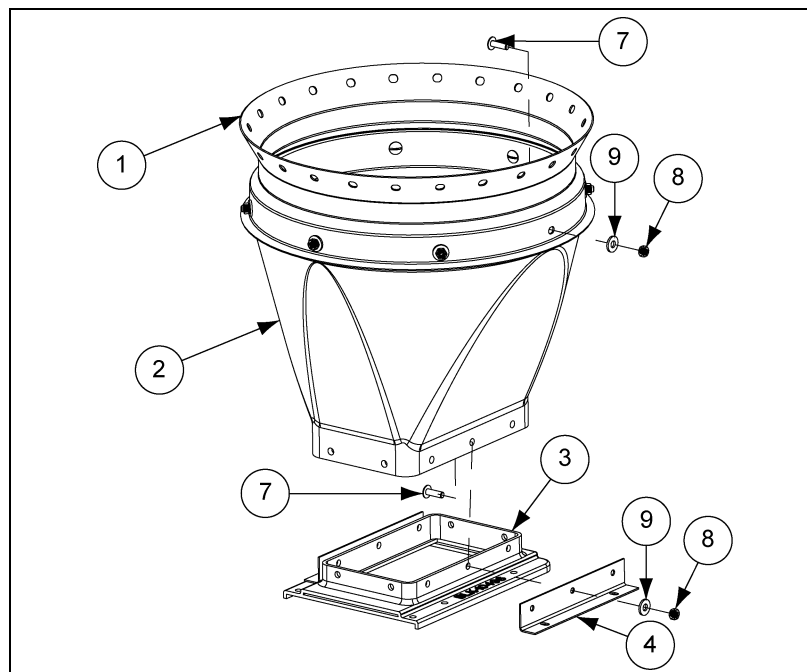

Figure 5C

5. Installation

Slide Gate Installation

Insert the slide into the transfer plate. The slide must be in its operating position prior to attaching the slide shield to the transfer plate. Use two (2) 5/16"-18 x 1" truss head tap bolts to mount the slide shield.

(See Figure 5D.)

Bolt unloader to transfer plate/unloader brace assembly as shown in Figure 5E. Note orientation of these bolts. (See Figure 5E.)

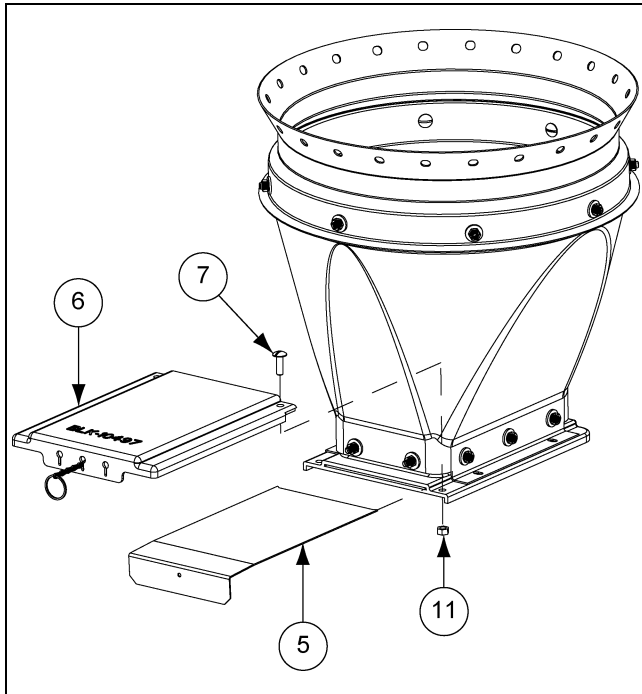

Figure 5D

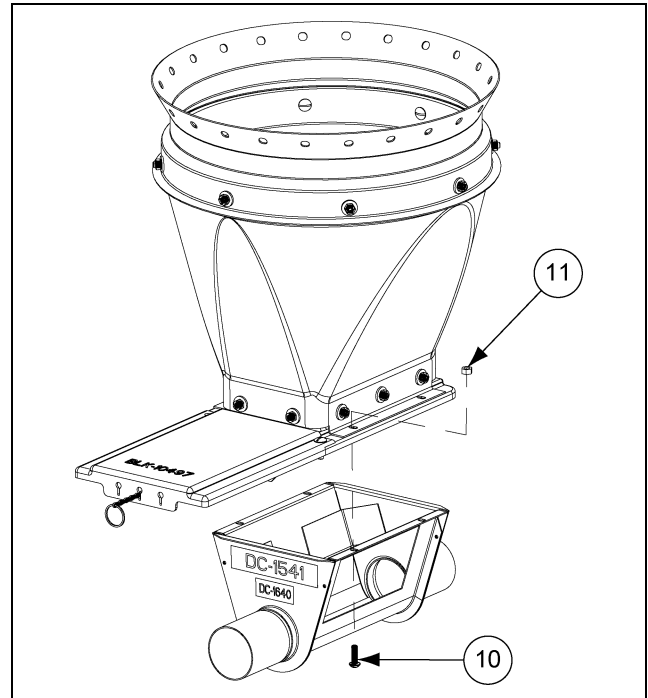

Figure 5E

Ref #	Part #	Description
1	BLK-10488	16" 67°, 16" Hopper Collar, (24 Holes)
1	BLK-10489	16" 60° Hopper Collar, (24 Holes)
1	BLK-11463	16" 60° Hopper Collar (27 Holes)
1	BLK-12342	16" 60° Hopper Collar (18 Holes)
2	FLX-2194	16" 30° Black Plastic Boot
2	FLX-2194C	16" 30° Clear Plastic Boot
2	FLX-2195	16" Straight Black Plastic Boot
2	FLX-2195C	16" Straight Clear Plastic Boot
2	FLX-4869	16" Double Straight Black Boot
3	BLK-10496	Transfer Plate
4	FLX-4819	Unloader Brace
5	FLX-4782	Slide Gate
6	BLK-10497	Slide Gate Shield
7	S-4336	5/16" x 1" Truss Head Machine Screw
8	S-4337	5/16"-18 Nylon Insert Nut
9	S-4338	5/16" Nylon Washer
10	S-8328	Screw, MS 5/16"-18 x 1" RHS ZN Grade 2
11	S-396	Hex Nut 5/16"-18 YDP Grade 2

Inspection/Clean-Out Plate Installation

Once the installation of the auger tubes and auger is complete, insert the inspection/clean-out plate or the optional unloader switch.

The inspection/clean-out plate is to be installed per the following instructions: *(See Figure 5F.)*

1. Back off both wing nuts to the stud ends.
2. Slide the plate onto the lower side of the unloader opening.
3. Move the plate first against the side of the unloader then upward toward the top of the unloader.
4. Tighten the wing nuts while holding the plate steady.

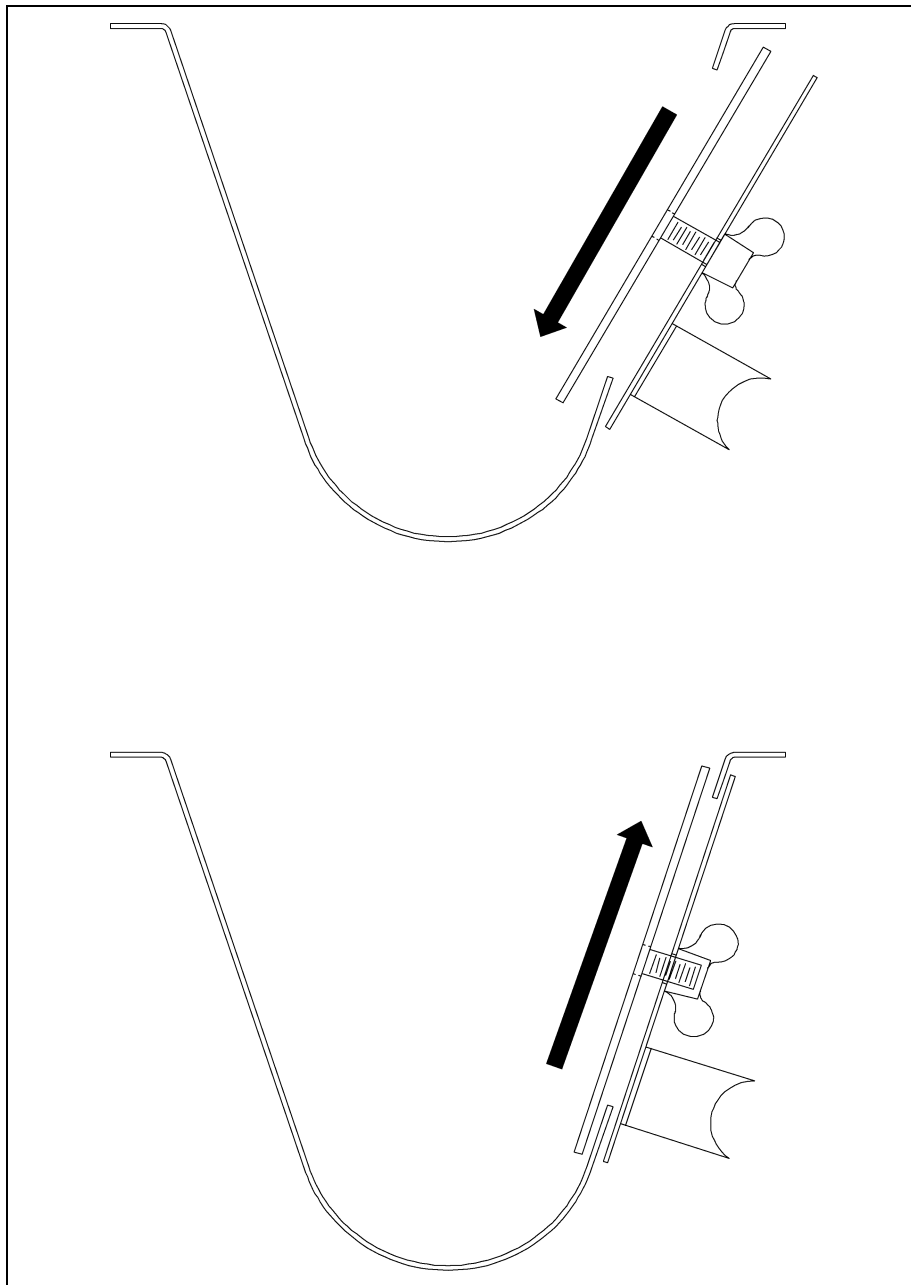

Figure 5F *Clean-Out Plate Installation*

5. Installation

Feed Tank Collar

The standard bulk feed tank is supplied with a 16" (40.64 cm) hopper opening. If needed, 22" (55.88 cm) hopper openings are also available. Consult the dealer for specific ordering instructions.

Restrictor Adjustment

The restrictor may be adjusted to allow more feed flow. Do not modify the restrictor until the system is completely operational and the auger has been polished by running feed through the system.

Instructions:

1. Remove the restrictor tube from the unloader.
2. Cut 1" (2.5 cm) from the restrictor. *(See Figure 5G.)*
3. Install the restrictor and the bearing assembly into the unloader.
4. Test the feed flow.
5. If the desired feed flow rate is not attained, repeat the above procedure until the desired rate is reached.

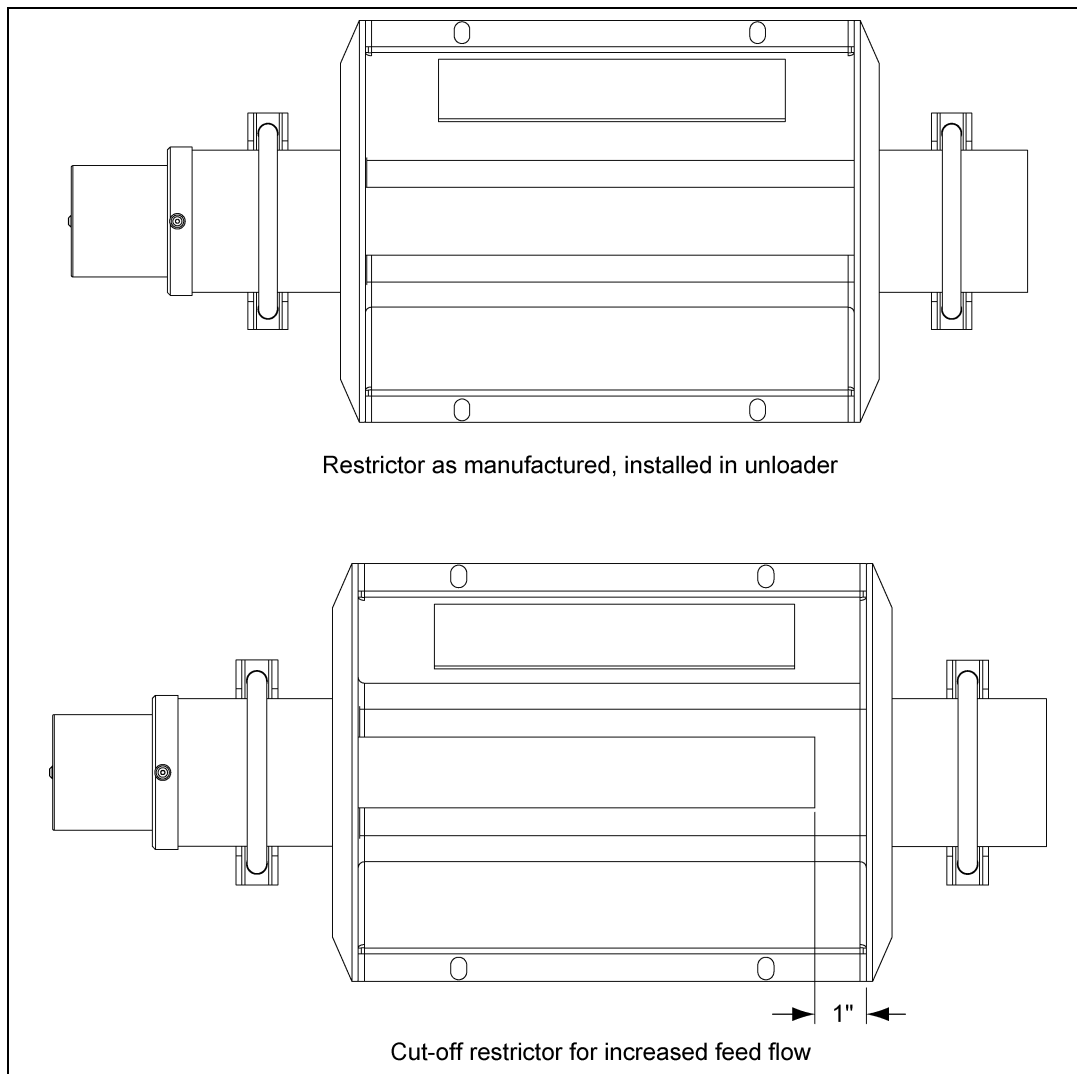

Figure 5G Restrictor Adjustment

Straight-Through Tandem Installation

The straight-through tandem system should be installed the same as a single tank system with the following exceptions:

1. Mount the boots on both tanks and the single or twin-out unloader as instructed.
2. Install baffle plate (FLX-4310) in the single-through unloader as shown in [Figure 5H](#). The twin unloader baffle is factory installed as shown in [Figure 5H](#).

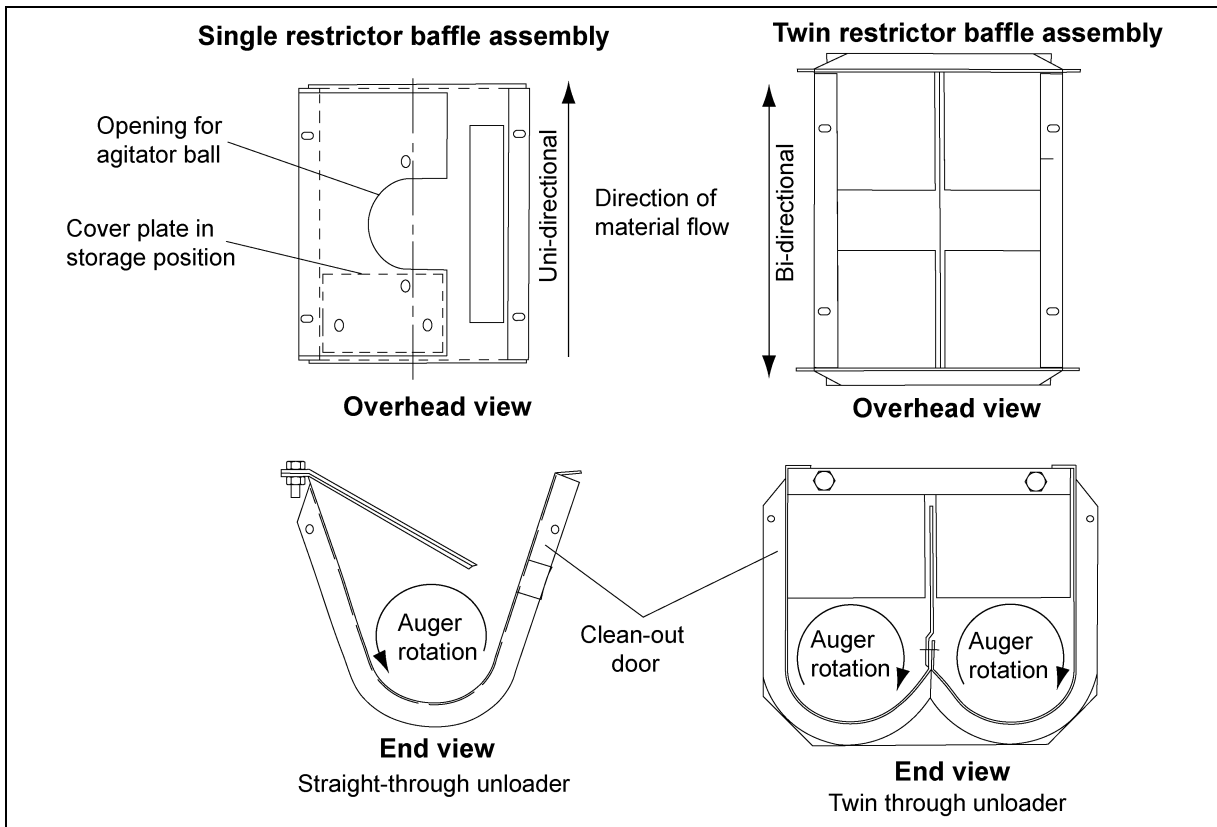

Figure 5H

3. Slide the belled end of a straight tube onto the unloader outlet on the first tank. Hold the straight tubing in the desired mounting position. Mark and cut the straight tube at the point where the tube and the inlet of the straight-through unloader inlet intersect.
4. Slip the appropriate tube coupler over the cut end of the straight tube. Position the straight tube in its operating location. Slide and clamp the tube coupler over the straight-through unloader inlet. (See [Figure 5I](#).)

NOTE: The coupler should be equally distributed between the tubing and the unloader inlet.

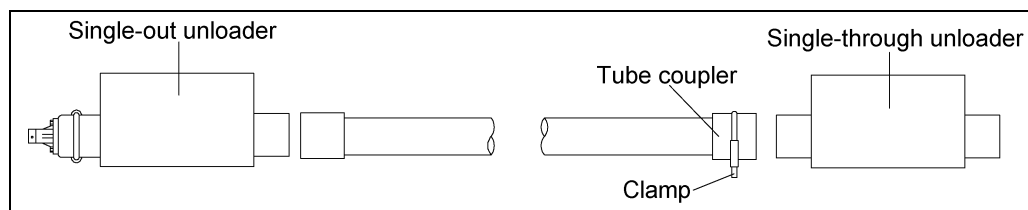

Figure 5I Tandem System Installation

5. Feed the auger through the single/twin-out unloader to the rest of the system and anchor as instructed.

Auger Tubing

Auger Tubing Installation

The auger tubing is one of the most important parts of the Flex-Flo Fill System. Proper installation is very important. Dry fit ALL parts before cementing or clamping. Once the complete system is fitting properly, cement or clamp the entire system.

The following steps are to be performed in the exact order shown:

1. Establish the entry point where the auger tube will enter the building. Once the entry point is determined, cut a hole large enough to accommodate the tubing. A seal ring and a neoprene seal are provided to seal the excess area between the tube and the hole in the building. The seal ring and the neoprene seal shall be installed as shown in [Figure 5J](#).

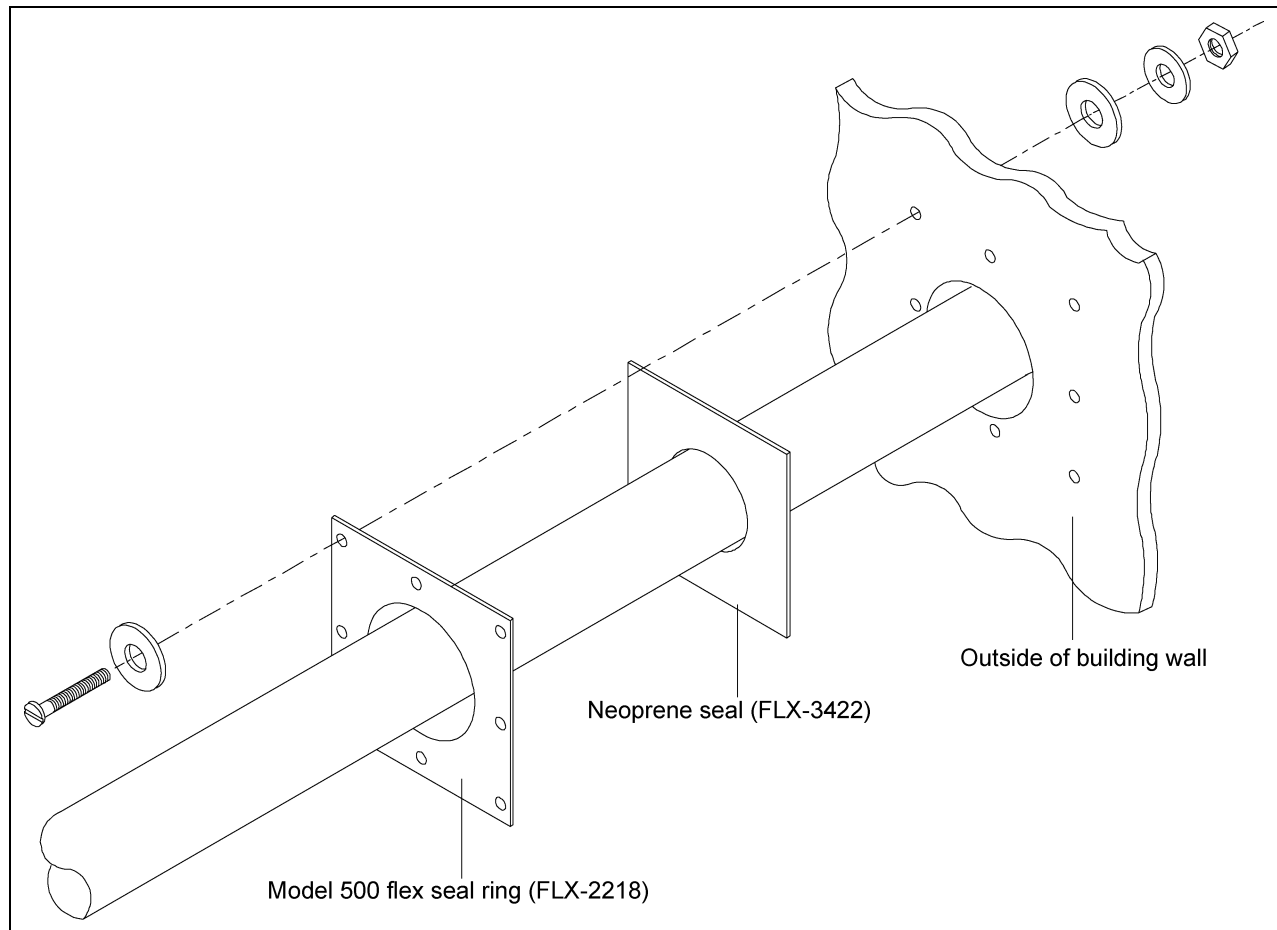

Figure 5J Seal Ring and Neoprene Seal Installation

2. Slide the elbow tubing through the hole in the building. Establish and cut (if necessary) the elbow at the desired length to ensure that the auger tubing will be horizontal. [See Figure 5K on Page 21](#) for proper cutting dimensions of the elbows at specific degree angles.
3. Fit and clamp a second elbow around the unloader outlet.
4. Slide the non-belled end of the straight tubing into the belled end of the “building” elbow. Hold the straight tubing in the desired mounting position. Mark and cut the “unloader” elbow at the point where it and the straight tubing intersect.

Auger Tubing Installation (Continued)

5. Remove the non-belled end of the straight tubing from the “building” elbow. Slide the belled end of the straight tubing over the freshly cut end of the “unloader” elbow. Mark and cut the straight tubing (as needed) so that it will fit inside the belled end of the “building” elbow.
6. Dry fit all of the outside tubing to ensure correct installation. Once satisfied, glue or clamp the tubing together as per the instructions in the section titled cementing procedure [on Page 22](#).
7. When the auger tubing between the unloader and the building is 15' (4.57 m) or longer, the tubes should be supported.
8. Locate and cut the outlet holes needed in the remaining straight tubes. For the exact size of outlet holes, see section titled outlet holes [on Page 22](#). Once ALL of the outlet holes are made and the tubing is dry fitted, glue or clamp the tubes together per the instructions in the section entitled cementing procedure [on Page 22](#).
9. Suspend the auger tubes and elbows from the ceiling at least once every four feet (4'). If horizontal elbows are used, support them in at least two (2) places. Chain and lag screws are provided in each suspension kit. The tubes should be kept as straight and level as possible.

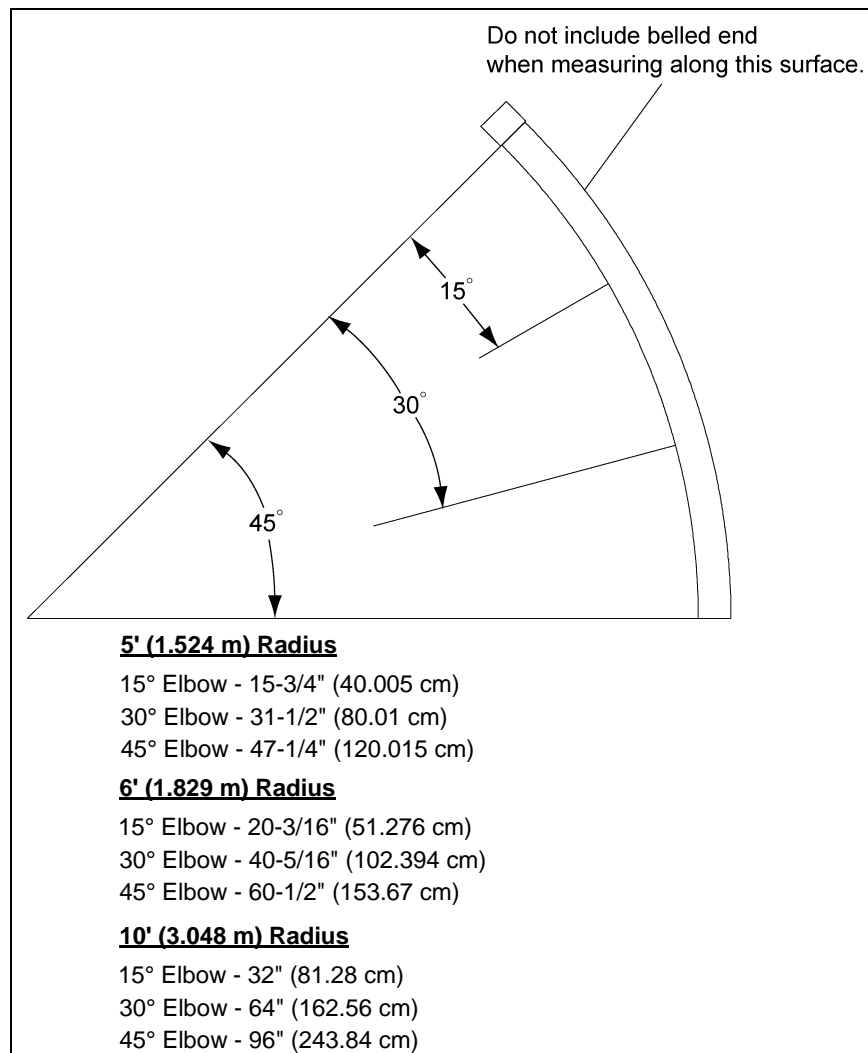

Figure 5K Cutting Chart for 45° Elbow

NOTE: *Align all outlet holes in proper functional positions prior to gluing the tube joints together.*

5. Installation

Cementing Procedure

Flex-Flo Systems have specially formulated PVC tubing. For strong tube connections, apply the PVC solvent cement per the instructions as follows:

1. Square tube ends and remove all burrs and dirt.
2. Check dry fit of tubes. The smaller end of the first tube should easily slide one-third of the way into the belled end of the second tube. The first tube end should be snug in the second tube once it is all the way in.
3. When the temperature is below 40°F (4°C) or above 85°F (29°C), consult PVC solvent cement container.
4. Apply a liberal coat of cement in the belled end. Avoid puddling inside.
5. Apply a liberal coat of cement on the smaller end, leaving no voids.
6. Assemble parts quickly. CEMENT MUST BE FLUID. If not fluid, re-coat both parts.
7. Push the smaller end into the belled end using a quarter turning motion until the small end bottoms.
8. Hold tubes together for 30 seconds, wipe off excess cement with cloth. Completed joints should not be disturbed until they have cured enough to withstand handling.

Keep container closed when not in use.

Outlet Holes

Establish where the outlet drops are to be. Once this is done, cut holes for the outlet drops. [See Figure 5L](#) for hole size recommendations. If total drop-out is necessary, it is recommended that the holes are cut using a saber saw or hacksaw. When carry-over is desired, it is recommended that the outlet holes are cut with a holesaw.

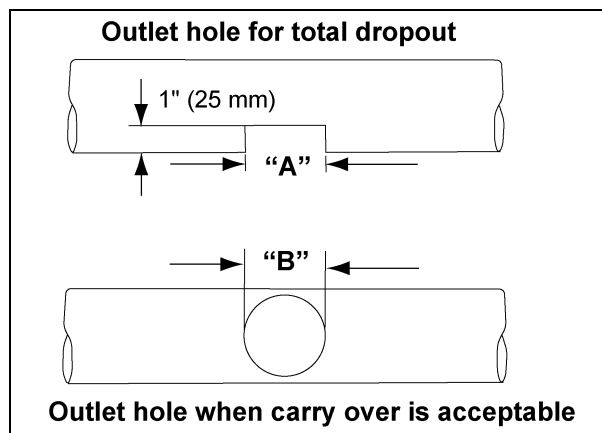

Figure 5L Outlet Hole Cutting Chart

Model	Full Drop	Carry-over
	Variable "A"	Variable "B"
220	1-1/2" (38 mm)	1-1/2" (38 mm)
300	2-1/2" (63 mm)	2-1/2" (63 mm)
350	3" (76 mm)	3" (76 mm)
500	4" (102 mm)	4" (102 mm)
HR	3" (76 mm)	2-1/2" (63 mm)

Drop Kit Installation

1. Wrap the rotary slide over the outlet hole and around the auger tube. Position the slides with cut-out facing in the same direction for all drops so that the slides will operate the same when the ropes are pulled.
2. Thread the rope through the ends of the rotary slide as shown in [Figure 5M](#) and tie the slide ends together so that the ends of the rope are the same length.

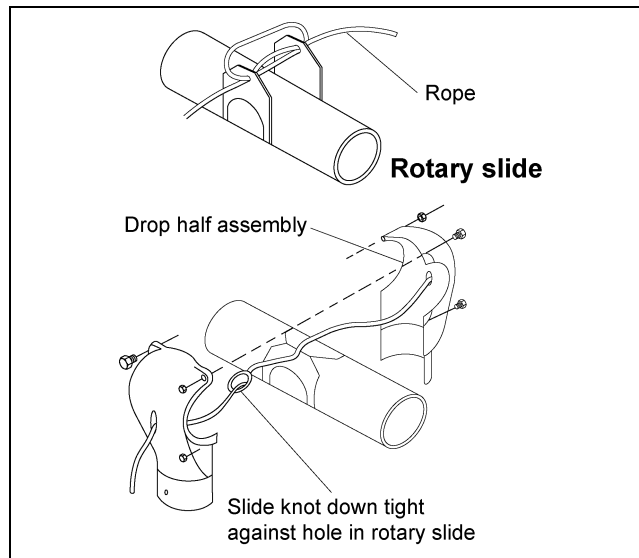

Figure 5M Drop Kit Installation

3. Slide rope through molded guide holes in drop halves.
4. Position the drop halves around the rotary slide and attach both halves together with the hardware provided as shown in [Figure 5N](#).

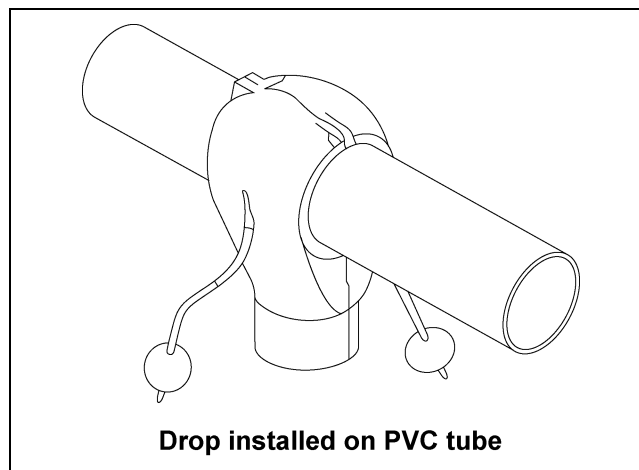

Figure 5N

5. Test the rotary slide. Pull on one rope at a time. Check the rotary slide to be sure it is centered over the outlet hole.
6. Slide the rotary slide to its open position by pulling the appropriate rope. Mark the short rope end at the point where it enters the guide hole. Tie a knot on the rope at the mark. The location of the knot will show at a glance if the slide is open or closed.

5. Installation

Drop Kit Installation (Continued)

7. Thread the short rope end through the red ball and tie a knot in the rope to hold the ball in place. Install the green ball the same way on the other rope end.
8. Apply a small amount of PVC cement around the drop to prevent it from moving around on the auger tube.
9. Two (2) screws are supplied for attaching an optional drop tube. *(See Figure 5N on Page 23.)* Use both screws to attach the drop tube securely to the drop kit.

Kwik-Attach Drop Kit Installation

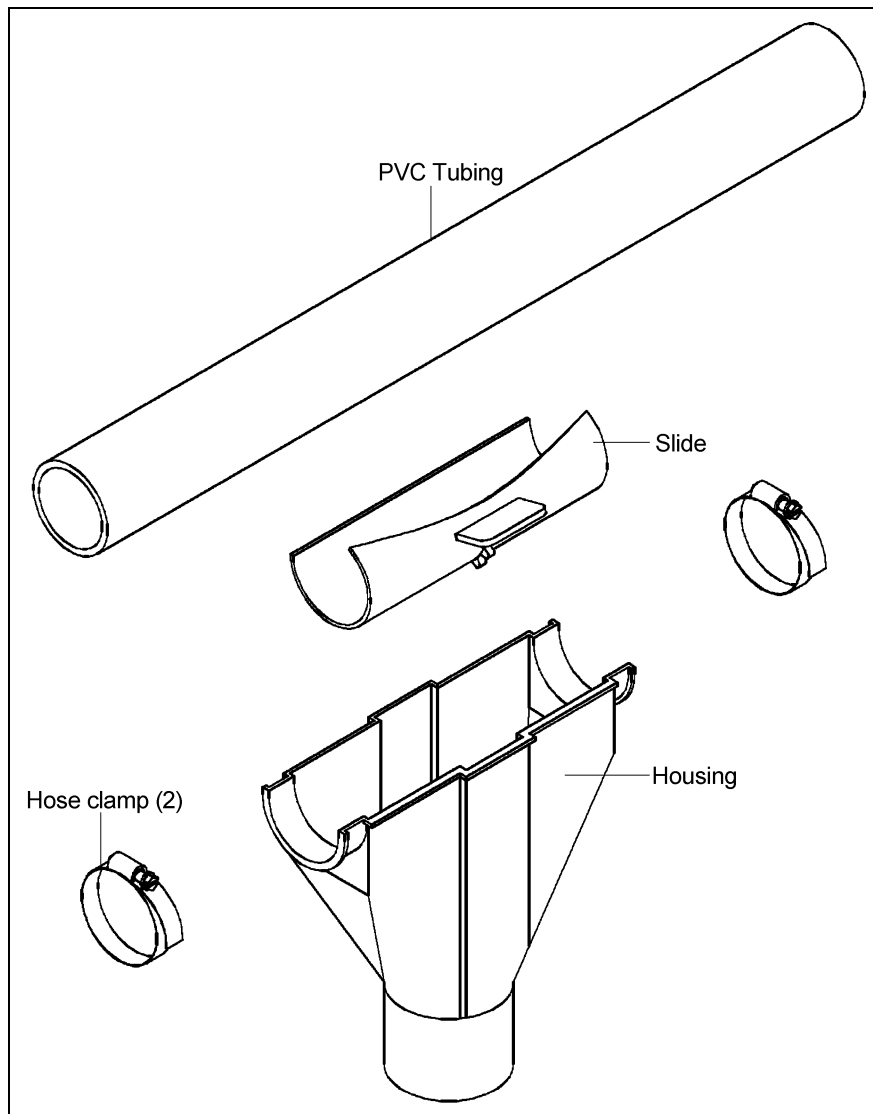

Figure 50 Drop Kit Installation

1. Snap the slide around the tube over the outlet hole. *(See Figure 50.)*
2. Fasten the housing to the tube using two (2) hose clamps. Make sure the outlet hole is in the middle of the housing.
3. Slide can be rotated from side to side to open and close the drop kit.

Power Unit and Control Unit



The safety switch on the control unit is provided as a backup switch in case the hopper level or the drop tube switch does not operate properly. This switch is not intended to be used for controlling the Flex-Flo System, but as a safety backup switch only.

Flex-Flo offers two (2) different types of power units, direct drive unit and belt drive power unit, along with the control unit. Installation instructions are provided with each power unit.

Horsepower requirements are based on length, type of Flex-Flo System installed, number of turns, tandem systems etc. [Table below](#) shows maximum line lengths for Flex-Flo Systems plus maximum lengths for extensions hopper installing, using various power units.

Reduction of the maximum line lengths in the chart should be allowed for if the system's incline is greater than 45° and/or the rise of the system is higher than 8' (2.44 m). For each additional 90° (2 elbows) used beyond chart, reduce the maximum line length for each drive unit by 30' (9.14 m). For each straight-out to straight-through tandem system, decrease the maximum line length for each drive unit size by 50' (15.24 m).



Figure 5P

Maximum Line Length

Motor Size	Model 220		Extension Pitch	Model 300		Model 350		Model 500				Model HR						
	Maximum Length	Maximum Extension		Maximum Length	Maximum Extension	Maximum Length	Maximum Extension	Maximum Length	Maximum Extension	Maximum Length	Maximum Extension	Maximum Length	Maximum Extension					
1/3 HP	150'	180'		-	-	-	-	Dry Feed Stuffs Moisture Levels below 18%				High-Moisture Systems Moisture Level from 18%-27%		-	-			
0.246 kW	46 m	91 m		-	-	-	-							-	-	-	-	-
1/2 HP	250'	300'	300'	80'	80'	30'	65'											30'
0.373 kW	24 m	38 m	38 m	24 m	38 m	9 m	20 m					7.6 m	12.7 m					
3/4 HP	-	-	400'	150'	150'	90'	90'	50'	50'	25'	25'	90'	90'					
0.559 kW	-	-		46 m	56 m	27 m	38 m					20.3 m	25.4 m					
1 HP	-	-		200'	245'	150'	185'	100'	100'	50'	65'	150'	180'					
0.746 kW	-	-		61 m	75 m	46 m	56 m					38.1 m	457 m					
1-1/2 HP	-	-		-	-	-	-	150'	180'	75'	90'	-	-					

The maximum length is for a system with three (3) elbows.

5. Installation

Direct Drive Power Unit/Control Unit

1. Bolt the tube anchor to the control unit body with a flat washer on each of the four (4) 5/16" x 3/4" bolts. (See [Figure 5Q](#) for more details.)
2. Slide the driver assembly onto the power unit drive shaft. Place the 5/16" hex socket bolt (supplied with the driver assembly) into the untapped hole of the driver through the drive shaft and tighten the bolt into threaded portion of the driver.
3. Mount the control unit to the gearbox unit with four (4) 5/16" x 3/4" bolts and four (4) flat washers, which are supplied with the power unit. (See [Figure 5R.](#))

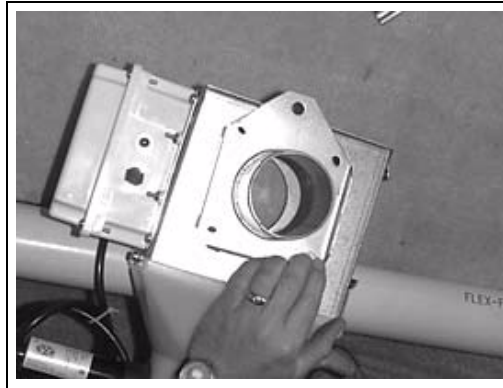

Figure 5Q Assembly of Tube Anchor to the Control Unit

4. The control unit and power unit require hard wiring. The supply line wires into L1 and L2/N of the relay in the control unit. The motor leads wire into the M1 and M2 of the relay in the control unit. Auxiliary switch is wired into the male and female spade terminal of the control unit. (See [Wiring Diagrams on Pages 55-62.](#))
5. Slide and clamp a tube coupler on the tube anchor.
6. Attach the power/control unit to the Flex-Flo tubing.
7. Suspend power/control unit firmly from the ceiling as shown in [Figure 5S](#). Support holes are provided on the power unit and the control unit.



Figure 5R Assembly of the Control Unit to the Dive Unit

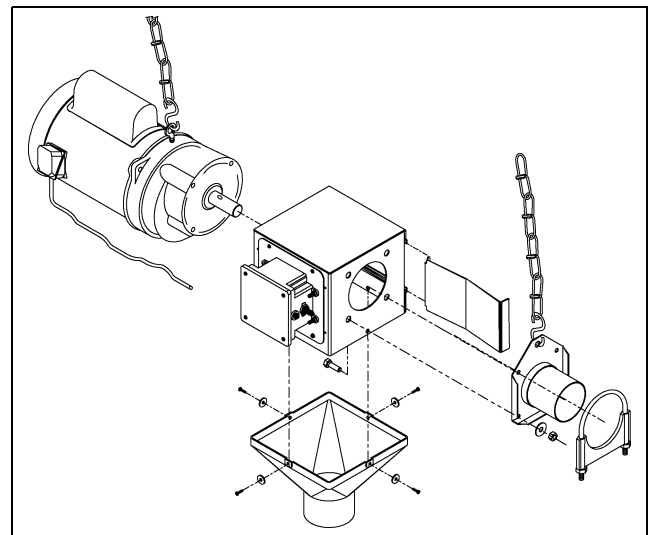

Figure 5S Direct Drive/Power Unit

Belt Drive Power/Control Unit

1. Bolt the tube anchor to the control unit body with a flat washer on each of the four (4) 5/16" x 3/4" bolts. (See [Figure 5Q on Page 26](#) for more details.)
2. Insert the driver shaft through the bearing assembly. The bearing mounting plate should be mounted in between. Tighten the set screw on the bearing down to the shaft.
3. Bolt the two (2) mounting brackets together with the four (4) bolts and washers provided.
4. Attach the motor support assembly to the control unit with the four (4) bolts already in the mounting bracket and belt guard. Secure with the four (4) lock washers and hex nuts provided. If necessary, motor orientation can be reversed by rotating the motor mount 180°.
5. Slide and clamp a tube coupler on the anchor.

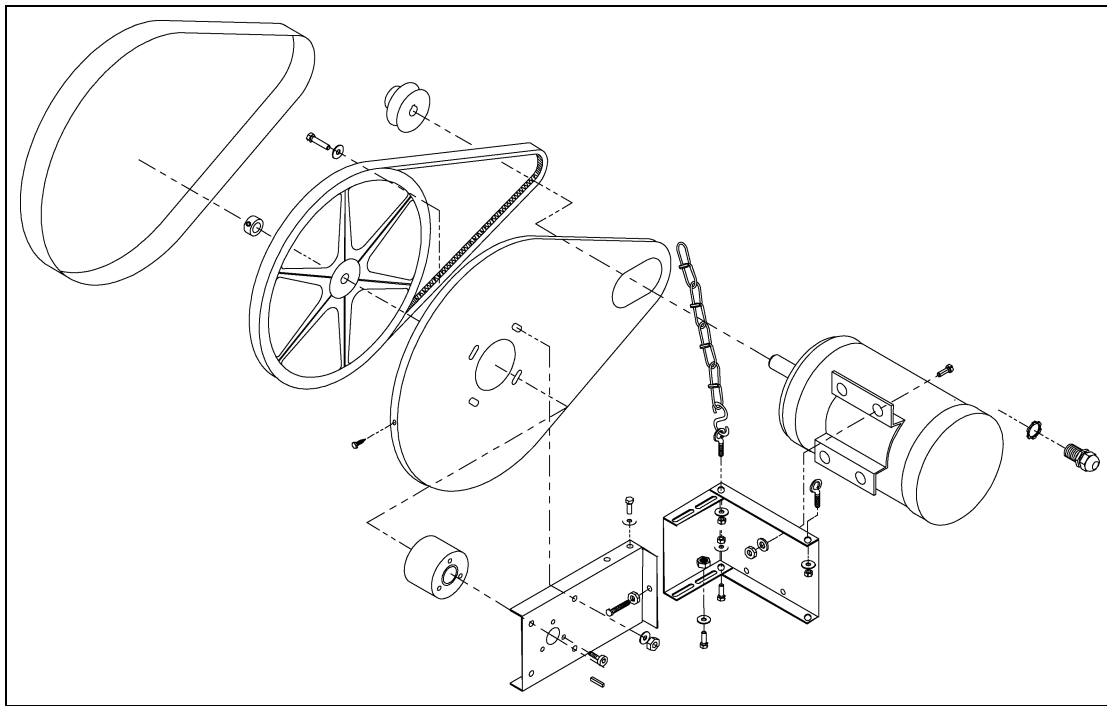

Figure 5T Belt Drive/Power Unit

6. Mount the motor onto the motor mount base with four (4) bolts and washers.
7. Mount the belt pulleys. The two (2) pulleys must be positioned in line with each other to prevent from binding the belt.
8. Install the belt.
9. Adjust the belt tension by extending and retracing the two (2) mounting brackets. Resecure the bolts after adjustment.
10. Install belt guard cover.
11. Attach the power/control unit to the Flex-Flo tubing.
12. Suspend the power/control unit firmly from the ceiling using the chains provided.
13. The control unit and the power unit must be wired as shown in the [Wiring Diagrams on Pages 55-62](#).
14. Install the auger.

5. Installation

Auger

The auger should be handled with great care. Do not install the auger until the kinks have been removed. The kink may be removed by straightening the auger. A kink may cause extensive wear on the system and premature part replacement. In the event that the kink cannot be removed by straightening, the kink must be cut-out and the auger welded. (See brazing recommendations in [Figure 5X on Page 29.](#))



Figure 5U

Auger Installation

Two (2) persons are required to install the auger. One person feeds the auger into the tubing while the other makes sure the auger is not damaged. Make sure no metal wires or loose ends enter the system.

1. The auger must be fed into the Flex-Flo System through the unloader. Remove the anchor from the unloader. Remove the control unit cover plate as well.
2. Feed the auger carefully into the Flex-Flo System through the unloader. Remove the anchor from the unloader and remove the control unit cover plate.
3. Push the auger in until it reaches the control unit at the other end. Fasten the end of the auger to the clamp pin in the control unit driver assembly. Tighten the 5/16" hex head cap screw holding the auger lock clamp pin to 23 ft-lbs. If the auger end is not in the appropriate orientation for connection, the driver assembly may be rotated by turning the motor drive shaft.
4. Pull and release the free end of the auger gently a few times. This action should relax the auger into its natural position.
5. A certain mechanical stress must be applied when installing the auger; therefore stretching the auger is very important. This is performed by drawing the auger out of the tubing. An important factor is the total system length. The auger should be drawn out of the tubing 2" (5 cm) for every 50' (15 m) of length for single feed tanks. For tandem systems, stretch the auger 4" (10 cm) for every 50' (15 m) of length.
6. While the auger is in the relaxed state, mark the auger at the unloader inlet.

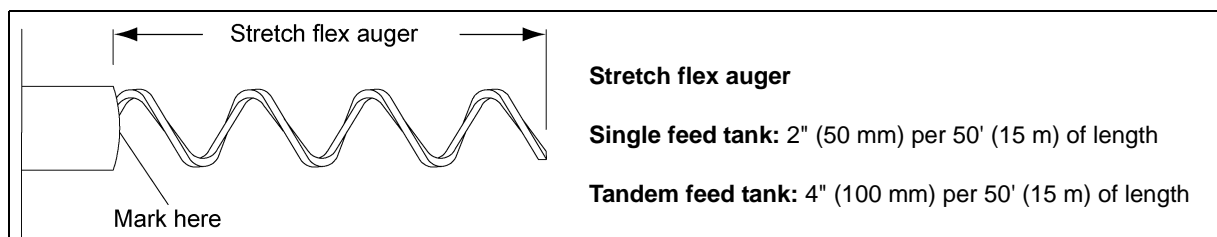

Figure 5V Stretching the Auger

Auger Installation (Continued)

7. Draw the auger out of the tubing as far as required. Measure the length between the mark and the unloader inlet. Mark the auger again at the unloader inlet when properly stretched. (See [Figure 5V on Page 28.](#)) Stretching the auger too far will cause premature wear at the inside bends of the PVC tubing. Stretching the auger not far enough will cause premature wear at the outside bends of the PVC tubing.
8. For ease of trimming the auger, pull the auger out an additional 8" (20 cm) past the mark and clamp it at the unloader. This clamping releases tension at the mark and thus eases cutting. (See [Figure 5W.](#))
9. Twist the unloader anchor into the auger and clasp the auger end in the clamp pin.
10. Mount the anchor in the unloader.
11. Place the cannonball inside the unloader.
12. Mount the cover on the control unit.
13. Place the inspection/clean-out plate in the unloader.

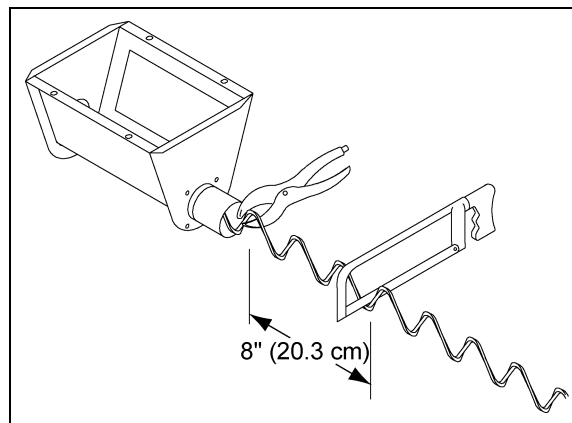

Figure 5W Cutting the Auger

Brazing the Auger

1. Make sure both ends are cleaned.
2. Position the auger in an angle iron and clasp it securely to align it for brazing. (See [Figure 5X.](#))
3. Braze both ends together. Use a bronze flux-coated rod. Make sure the auger does not get too hot which might cause the auger to warp.
4. After the brazing is performed, the joint should be allowed to air cool.
5. Once the auger has cooled, install the auger with the brazed joint closer to the power unit.

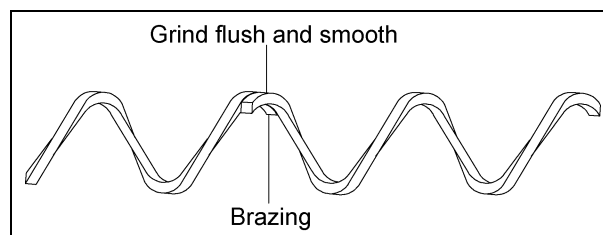

Figure 5X Brazing the Auger

Extension Hopper Installation

1. To ease the installation, mount the extension hopper top section to the Flex-Flo tubing.

NOTE: A. Slide the tube clamp on the hopper tube anchor prior to attaching it to the tubing.

B. Make certain when mounting the power unit and the tubing that they are attached to the access slide side. When mounted in this orientation, the incoming auger is positioned as far away as possible to allow the upper control switch to operate properly.

2. Suspend the top section from the ceiling as shown in [Figure 5Y](#). Support holes are provided on the top section for mounting. When mounting, make allowance for future adjustments of the top section after the bottom section has been connected.

NOTE: Any additional support given to the extension hopper makes for a more solid system and is desirable. Take special care if or when the support is modified that the operation of the system and the ability to do a general maintenance are not hindered.

3. Mount the unloader under the control unit. The control unit should be assembled together prior to mounting. This assembly includes the driver assembly. Suspend the control unit firmly from the ceiling. Support holes are provided on the tube anchor.

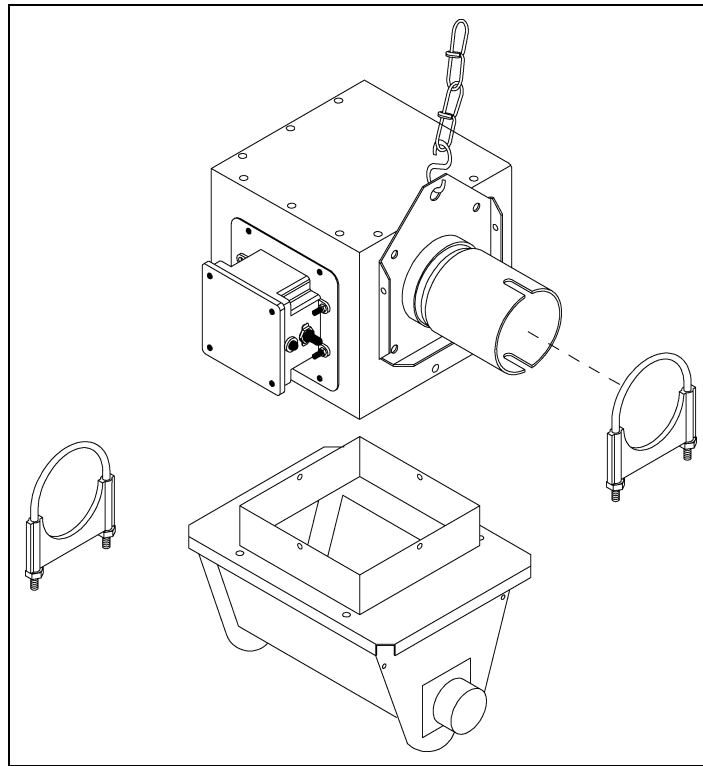

Figure 5Y Extension Hopper

4. Fasten the end of the auger to the anchor in the control unit driver assembly. Tighten the 5/16" hex head cap screw holding the auger lock clamp pin to 23 ft-lbs. If the auger end is not in the appropriate orientation for connection, the driver assembly may be rotated by either turning the motor shaft with a wrench or by turning the large pulley to rotate the driver assembly.
5. Remove the anchor assembly and the rear access panel from the bottom section of the extension hopper. Mount the bottom section to the top section with 1/4"-20 machine screws provided with the hopper. The bottom section may be mounted in three (3) various directions. ([See Figure 5Z on Page 31.](#))

Extension Hopper Installation (Continued)

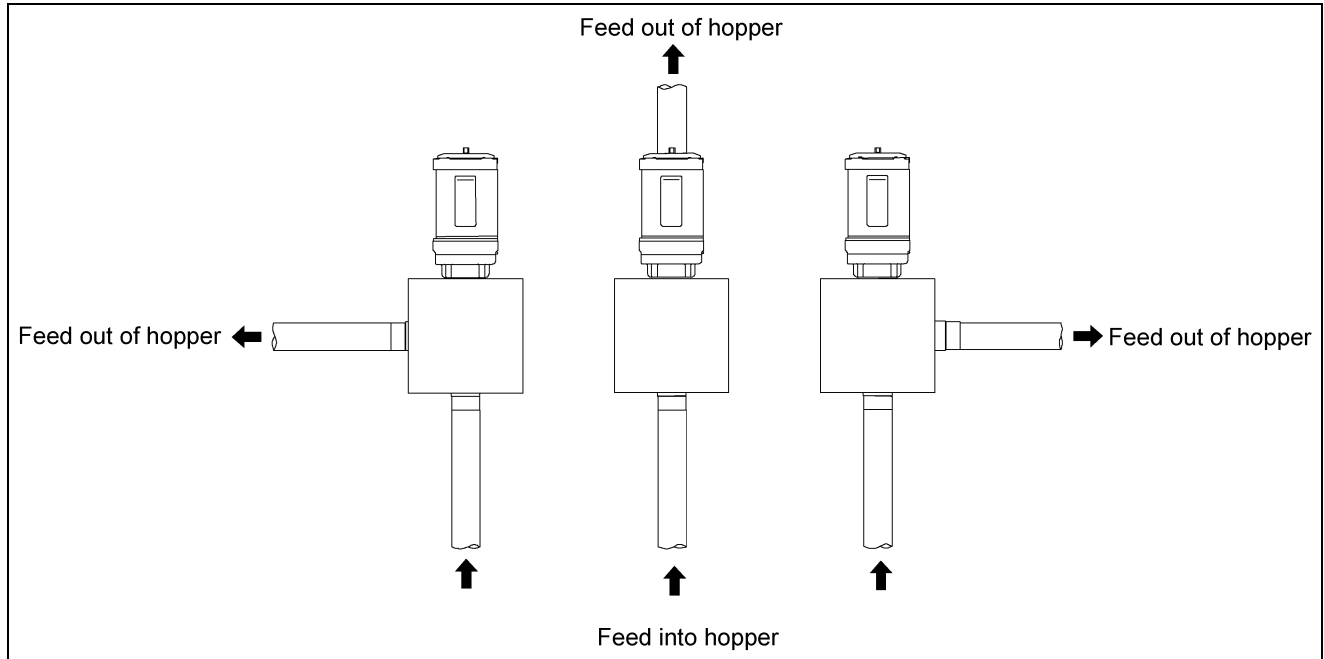

Figure 5Z Extension Mounting Directions

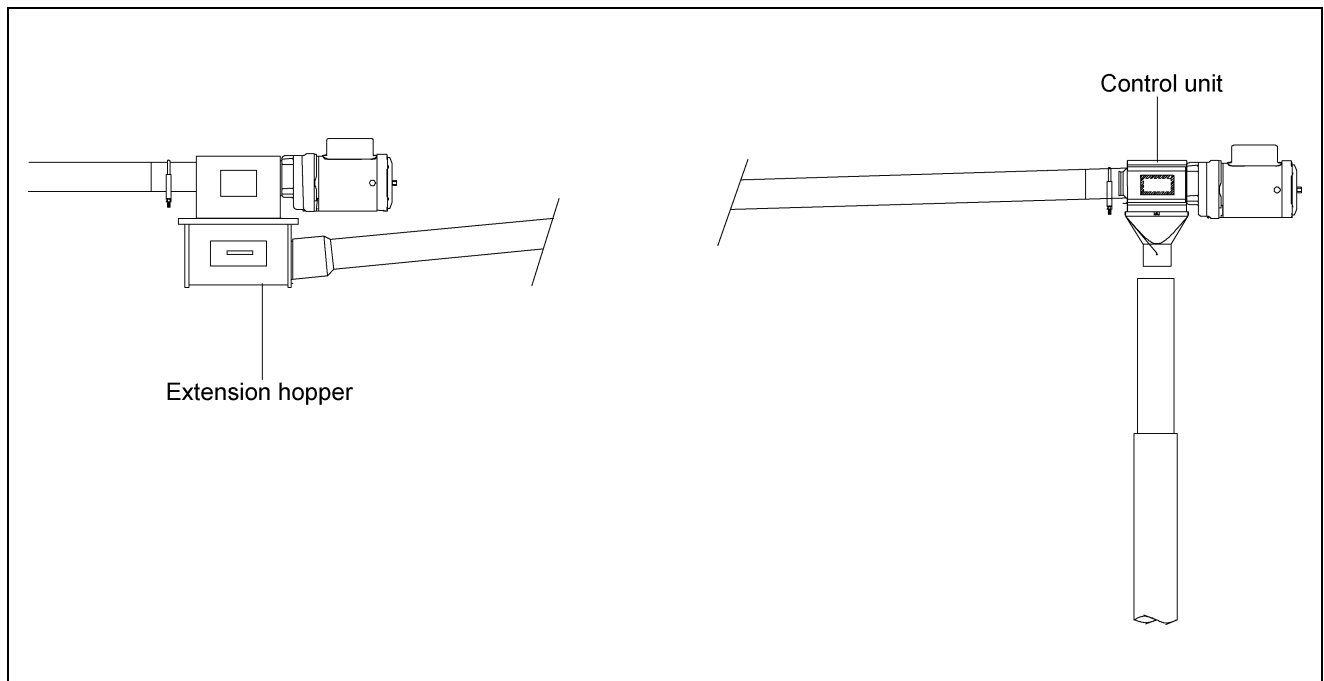

Figure 5AA Extension System

6. Install the auger for the system that is connected from the tank(s) to the extension hopper. Install as a standard system. The auger for the second part of the system should connect to the power/control unit at the other end.
7. Clamp the auger ends to their applicable anchors and mount the bearing assemblies in place.

5. Installation

8. The extension unit switch should actuate prior to “bottoming out” when pressed in and return back to its original position after it is released.



Figure 5AB

Operation Guidelines

1. Open the unloader slide completely for the delivery system operation except on tandem system.
2. Do not operate the Flex-Flo System empty. Utilize a time clock with the system whenever possible because:
 - A. It lessens short cycling by operating on a set schedule versus on demand.
 - B. It prohibits the system from running excessively when empty if the tank should go dry. When the optional unloader switch is used, it should be wired so that if the feed tank goes empty the power unit will stop.
3. The time clock should be programmed to start the Flex-Flo System often. By running the system often, long running periods are eliminated and the feeders are kept full. When the Flex-Flo System is used for filling poultry feeders, a time clock should be utilized to ensure that all feeders are filled at the same time. The Flex-Flo System will have a better opportunity to keep up. Position the hopper level control low in the last hopper.
4. A safety switch is provided on the control unit to trip out the motor in the event that feed is packed inside. If feed does get packed, dislodge the feed from the drop tube and clean-out the inside of the control unit which will allow the switch to close. The hopper level control needs to maintain vertical positioning to keep the paddle swinging freely. Check the adjustment regularly. The control unit safety switch does not replace the hopper level control.
5. When the Flex-Flo System is used to convey high-moisture feed, the auger line should be completely emptied after each running to prevent feed from jamming in the tubes.
6. Operate the manual outlets several times each week to free them of feed debris.
7. The restrictor on the unloader anchor controls the feed that is flowing into the auger. When starting a new system, the restrictor should be installed at full length and flush with the front of the unloader. Permit the system to polish out the inside of the tubing before modifying the feed flow. When the restrictor tube is in the unloader, maximum restriction is reached. When increased feed flow is desired, the length of the restrictor tube should be decreased.

8. When a multi-story building is supplied by one auger solely, obtain total drop-out at each outlet. A time clock MUST be utilized to ensure that all of the feeders are filled at the same time. In the last hopper on every level, install a hopper level control.
9. With the straight-through tandem system, open only one tank slide at a time when feeding. Operating the system with both unloader slides open is not recommended since horsepower consumption increases considerably.

Wire Size by Type

Motor HP	Full Load Amps	Minimum Allowable Wire Size		
		In Cable, Conduit or Earth		Overhead in Air
		Type: R, T, W	Type: RH, RHW, THW	Bare and Covered Conductors
1/2	4.9	12	12	10
3/4	6.9	12	12	10
1	8.0	12	12	10
1-1/2	10.0	12	12	10

Copper conductors, 1 phase 230V, 3% voltage drop.

In case of conductors supplying several motors on one circuit, the wire size is determined by taking 125% of the full load current of the largest motor and 100% for all others.

Wire Size by Length of Run

Motor	Length of Run - Ft. (m)														
	50	75	100	150	200	250	300	350	400	500	600	700	800	900	1000
Size	(15)	(22.5)	(30)	(45)	(60)	(75)	(90)	(105)	(120)	(150)	(180)	(210)	(240)	(270)	(300)
1/2 HP	12	12	12	12	12	12	12	12	12	10	10	8	8	8	8
3/4 HP	12	12	12	12	12	12	12	10	10	8	8	8	6	6	6
1 HP	12	12	12	12	12	10	10	8	8	8	6	6	6	6	6
1-1/2 HP	12	12	12	10	10	8	8	8	6	6	6	6	4	4	4

NEC Sec. 225-6/: Conductors in overhead spans must be at least #10 for spans up to 50' and #8 for longer.

NOTES

1. Flex-Flo Feed Line Components
2. Direct Drive Power Unit Assemblies
3. Model 220 Unloader and Anchor Assembly
4. Model 300, 350 and HR Unloader and Anchor Assembly
5. Model 500 Unloader and Anchor Assembly
6. Direct Drive and Tube Anchor
7. Belt Drive and Tube Anchor
8. Model 220, 300 and 350 Control Unit (FLX-4496)
9. Flex-Flo Control Unit (FLX-5015)
10. Belt Drive Power Unit
11. Direct Drive Power Unit
12. Drop Kit/Kwik-Attach Drop Kit
13. Unloader Switch
14. Micro Drop Tube Switch/Proximity Switch

6. Parts List

Flex-Flo Feed Line Components

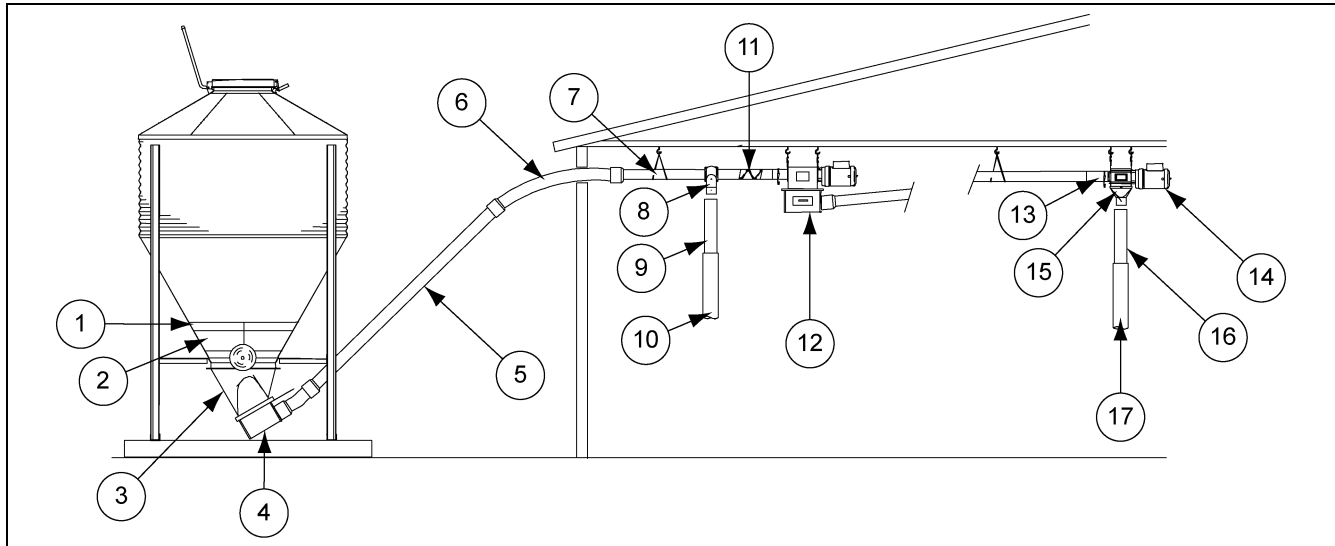

Ref #	Model 220	Model 300	Model 350	Model 500	Model HR	Description
1	BLK-10847	BLK-10847	BLK-10847	BLK-10847	BLK-10847	16" 45° Hopper Extension Kit w/ Collar
1	BLK-10587	BLK-10587	BLK-10587	BLK-10587	BLK-10587	22"-16" 60° Hopper Extension Kit w/ Hopper Collar
1	BLK-10591	BLK-10591	BLK-10591	BLK-10591	BLK-10591	22"-16" 67° Hopper Extension Kit w/ Hopper Collar
3	FLX-2194	FLX-2194	FLX-2194	FLX-2194	FLX-2194	16" 30° Black Plastic Boot
3	FLX-2194C	FLX-2194C	FLX-2194C	FLX-2194C	FLX-2194C	16" 30° Clear Plastic Boot
N/S	FLX-2195	FLX-2195	FLX-2195	FLX-2195	FLX-2195	16" Straight Black Plastic Boot
N/S	FLX-2195C	FLX-2195C	FLX-2195C	FLX-2195C	FLX-2195C	16" Straight Clear Plastic Boot
4	FLX-4408	FLX-2243	FLX-2178	FLX-2943	FLX-4773	Single-Out Unloader (No Anchor)
N/S	FLX-3937	FLX-2586	FLX-2181	FLX-4743	FLX-4772	Twin-Out Unloader (No Anchor)
5	PVC-1004	PVC-1005	PVC-1006	PVC-1007	PVC-1006	10' PVC Straight Tube
6	PVC-1101	PVC-1001	PVC-1002	PVC-1003	PVC-1002	45° Elbow, 5' Radius (PVC-1003 is 6' Radius)
6	PVC-1000					45° Elbow, 10' Radius
7	S-4694	S-4694	S-4694	S-4694	S-4694	#2 Weldless Chain
7	S-7313	S-7313	S-7313	S-7313	S-7313	Eye Screw 1/4"-20 x 3-1/2" ZN (Open Eye Screw)
8	FLX-2432	FLX-2433	FLX-2434	FLX-2435	FLX-2434	Drop Kit
9	FLX-2425	FLX-2425	FLX-2427	FLX-2429	FLX-2427	12' Drop Tube
10	FLX-2426	FLX-2426	FLX-2428	FLX-2430	FLX-2428	6' Telescoping Drop Tube
11	FLXA-1520	FLXA-2390	FLXA-2710	FLXA-3800	FLXA-2390	Flex-Flo Auger
12	FLX-4682E	FLX-4684E	FLX-4686E	FLX-2542	FLX-4687E	Extension Unit
13	FLX-2537	FLX-2538	FLX-2539	FLX-2540	FLX-2539	PVC Tube Coupler
14	See Direct Drive Power Unit Assembly Part Numbers on Pages 37-39 .					
N/S	012-1	012-1	012-1		012-1	1/2 HP Belt Drive Motor, 110/220V, 1 PH, 60 Hz, Farm Duty (5/8" Shaft)
N/S		034-1	034-1	034-1	034-1	3/4 HP Belt Drive Motor, 110/220V, 1 PH, 60 Hz, Farm Duty (5/8" Shaft)
N/S		100-1	100-1	100-1	100-1	1 HP Belt Drive Motor, 110/220V, 1 PH, 60 Hz, 1750 RPM (5/8" Shaft)
15	FLX-4496	FLX-4496	FLX-4496	FLX-4497	FLX-4496	Direct Drive Control Unit, 220V
N/S	FLX-4179	FLX-4179	FLX-4179	FLX-4179		Belt Drive Control Unit (No Motor)
16	FLX-2427	FLX-2427	FLX-2427	FLX-2429	FLX-2427	12' Drop Tube
17	FLX-2428	FLX-2428	FLX-2428	FLX-2430	FLX-2428	6' Telescoping Drop Tube

Direct Drive Power Unit Assemblies

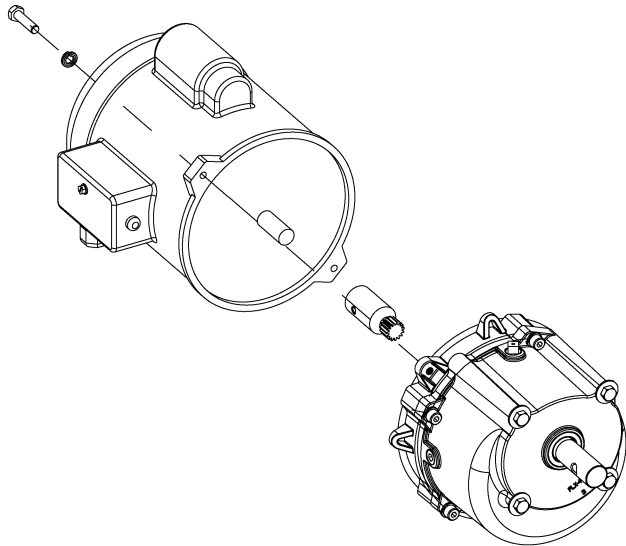

Gearbox orientation type A

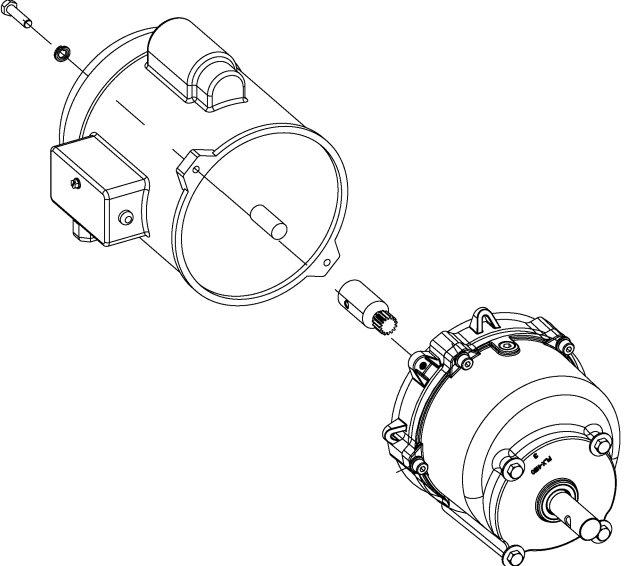
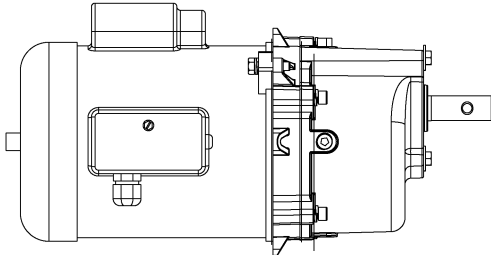

Gearbox orientation type B

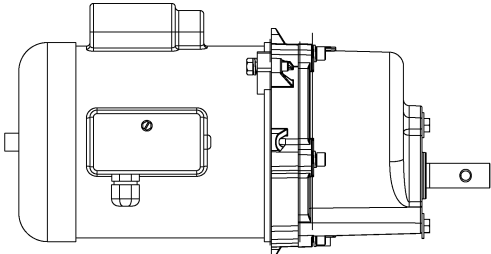

6. Parts List

Direct Drive Power Unit Assemblies Parts List

Direct Drive Power Unit Gearbox Orientation		
Part #		Description
Type A	Type B	
FLX-4873	FLX-4873R	DDPU, 250 RPM, 1/2 HP, 3 PH, 60 Hz, 208-230/460V
FLX-4867	FLX-4867R	DDPU, 441 RPM, 1 HP, 3 PH, 60 Hz, 208-230/460V
FLX-4754	FLX-4754R	DDPU, 298 RPM, 1 HP, 3 PH, 50 Hz, 190/380V
FLX-4645	FLX-4645R	DDPU, 250 RPM, 1 HP, 3 PH, 50 Hz, 190/380V
FLX-4632	FLX-4632R	DDPU, 250 RPM, 1 HP, 3 PH, 60 Hz, 208-230/460V
FLX-4355	FLX-4355R	DDPU, 358 RPM, 1-1/2 HP, 3 PH, 60 Hz, 600V
FLX-4043	FLX-4043R	DDPU, 358 RPM, 1 HP, 3 PH, 60 Hz, 208-230/460V (E.P.)
FLX-4041-1PH	FLX-4041-1PHR	DDPU, 358 RPM, 1/2 HP, 1 PH, 60 Hz, 208-230/240V (E.P.)
FLX-3911	FLX-3911R	DDPU, 358 RPM, 1 HP, 3 PH, 60 Hz, 600V
FLX-3671	FLX-3671R	DDPU, 368 RPM, 1-1/2 HP, 3 PH, 50 Hz, 190-380/440V
FLX-3670	FLX-3670R	DDPU, 368 RPM, 1 HP, 3 PH, 50 Hz, 190/380V
FLX-3661	FLX-3661R	DDPU, 368 RPM, 1-1/2 HP, 1 PH, 50 Hz, 110/220V
FLX-3652	FLX-3652R	DDPU, 539 RPM, 1 HP, 3 PH, 60 Hz, 208-230/460V
FLX-3644	FLX-3644R	DDPU, 156 RPM, 1 HP, 3 PH, 60 Hz, 208-230/460V
FLX-3641	FLX-3641R	DDPU, 441 RPM, 1-1/2 HP, 1 PH, 60 Hz, 115/230V
FLX-3640-60	FLX-3640-60R	DDPU, 441 RPM, 1 HP, 1 PH, 60 Hz, 115/230V
FLX-3640-50	FLX-3640-50R	DDPU, 368 RPM, 1 HP, 1 PH, 50 Hz, 110/220V
FLX-3632	FLX-3632R	DDPU, 368 RPM, 1/2 HP, 3 PH, 50 Hz, 190/380V
FLX-3555	FLX-3555R	DDPU, 358 RPM, 1-1/2 HP, 3 PH, 60 Hz, 208-230/460V
FLX-3552	FLX-3552R	DDPU, 358 RPM, 1 HP, 3 PH, 60 Hz, 208-230/460V
FLX-3549BA	FLX-3549BAR	DDPU, 358 RPM, 1/2 HP, 3 PH, 60 Hz, 208-230/460V
FLX-3549	FLX-3549R	DDPU, 358 RPM, 1/2 HP, 3 PH, 60 Hz, 208-230/460V
FLX-3546	FLX-3546R	DDPU, 358 RPM, 1/3 HP, 3 PH, 60 Hz, 230/460V
FLX-3543BA	FLX-3543BAR	DDPU, 358 RPM, 3/4 HP, 3 PH, 60 Hz, 208-230/460V
FLX-3543	FLX-3543R	DDPU, 358 RPM, 3/4 HP, 3 PH, 60 Hz, 208-230/460V
FLX-3535	FLX-3535R	DDPU, 296 RPM, 1-1/2 HP, 3 PH, 50 Hz, 190-380/440V
FLX-3534	FLX-3534R	DDPU, 296 RPM, 1 HP, 3 PH, 50 Hz, 190/380V
FLX-2933-60	FLX-2933-60R	DDPU, 64 RPM, 1/3 HP, 1 PH, 60 Hz, 115/230V
FLX-2462	FLX-2462R	DDPU, 358 RPM, 1-1/2 HP, 1 PH, 60 Hz, 115/230V
FLX-2461-60	FLX-2461-60R	DDPU, 358 RPM, 1 HP, 1 PH, 60 Hz, 115/230V
FLX-2460-60	FLX-2460-60R	DDPU, 358 RPM, 3/4 HP, 1 PH, 60 Hz, 115/230V
FLX-2460-50	FLX-2460-50R	DDPU, 296 RPM, 3/4 HP, 1 PH, 50 Hz, 110/220V
FLX-2459-60	FLX-2459-60R	DDPU, 358 RPM, 1/2 HP, 1 PH, 60 Hz, 115/230V
FLX-2459-50	FLX-2459-50R	DDPU, 296 RPM, 1/2 HP, 1 PH, 50 Hz, 115/230V
FLX-2458-60	FLX-2458-60R	DDPU, 358 RPM, 1/3 HP, 1 PH, 60 Hz, 110/220V
C2000203	C2000203R	DDPU, 84 RPM, 1/2 HP, 1 PH, 50 Hz, 115/230V
07101557-60	07101557-60R	DDPU, 250 RPM, 1/2 HP, 1 PH, 60 Hz, 115/230V (CU)
07101481-60	07101481-60R	DDPU, 250 RPM, 1/3 HP, 1 PH, 60 Hz, 115/230V (CU)

Direct Drive Power Unit Assemblies Parts List (Continued)

Direct Drive Power Unit Gearbox Orientation		
Part #		Description
Type A	Type B	
07100643-60	07100643-60R	DDPU, 64 RPM, 1/2 HP, 1 PH, 60 Hz, 115/230V
07099366-60	07099366-60R	DDPU, 358 RPM, 1/2 HP, 1 PH, 60 Hz, 115/230V (CU)
07098924-50	07098924-50R	DDPU, 368 RPM, 1/2 HP, 1 PH, 50 Hz, 115/230V (CU)
07097965-60	07097965-60R	DDPU, 358 RPM, 3/4 HP, 1 PH, 60 Hz, 115/230V (CU)
07097744-60	07097744-60R	DDPU, 358 RPM, 1/2 HP, 1 PH, 60 Hz, 115/230V (CU)
07097374-60	07097374-60R	DDPU, 358 RPM, 1/3 HP, 1 PH, 60 Hz, 115/230V (CU)
7100693	7100693R	DDPU, 735 RPM, 3/4 HP, 3 PH, 60 Hz, 208-230/460V (CU)
7099968	7099968R	DDPU, 84 RPM, 1/3 HP, 3 PH, 50 Hz, 190/380V
7099342	7099342R	DDPU, 358 RPM, 3/4 HP, 3 PH, 60 Hz, 208-230/460V (CU)
7099341	7099341R	DDPU, 358 RPM, 1/2 HP, 3 PH, 60 Hz, 208-230/460V (CU)
7099340	7099340R	DDPU, 358 RPM, 1/3 HP, 3 PH, 60 Hz, 230/460V (CU)
7099298	7099298R	DDPU, 368 RPM, 3/4 HP, 3 PH, 50 Hz, 190/380V (CU)
7099263	7099263R	DDPU, 368 RPM, 1/2 HP, 3 PH, 50 Hz, 190/380V (CU)
7099247	7099247R	DDPU, 735 RPM, 3/4 HP, 3 PH, 50 Hz, 230/380/440V (CU)
7098894	7098894R	DDPU, 716 RPM, 3/4 HP, 1 PH, 60 Hz, 115/230V (CU)
7098423	7098423R	DDPU, 441 RPM, 1/3 HP, 1 PH, 50 Hz, 115/230V (CU)
7098422	7098422R	DDPU, 368 RPM, 1/3 HP, 3 PH, 50 Hz, 190/380V (CU)
FLX-3582-50	FLX-3582-50R	DDPU, 129 RPM, 1/2 HP, 1 PH, 50 Hz, 115/230V
FLX-3582-60	FLX-3582-60R	DDPU, 156 RPM, 1/2 HP, 1 PH, 60 Hz, 115/230V
FLX-3593	FLX-3593R	DDPU, 156 RPM, 1/2 HP, 3 PH, 60 Hz, 230/460V
FLX-3928-50	FLX-3928-50R	DDPU, 129 RPM, 3/4 HP, 1 PH, 50 Hz, 110/220V
FLX-3928-60	FLX-3928-60R	DDPU, 156 RPM, 3/4 HP, 1 PH, 60 Hz, 115/230V
FLX-3634-50	FLX-3634-50R	DDPU, 129 RPM, 1 HP, 1 PH, 50 Hz, 110/220V
FLX-3634-60	FLX-3634-60R	DDPU, 156 RPM, 1 HP, 1 PH, 60 Hz, 115/230V
FLX-3635	FLX-3635R	DDPU, 156 RPM, 1-1/2 HP, 1 PH, 60 Hz, 115/230V
FLX-2672-60	FLX-2672-60R	DDPU, 250 RPM, 1/3 HP, 1 PH, 60 Hz, 115/230V
FLX-2673-60	FLX-2673-60R	DDPU, 250 RPM, 1/2 HP, 1 PH, 60 Hz, 115/230V
FLX-2674-50	FLX-2674-50R	DDPU, 209 RPM, 3/4 HP, 1 PH, 50 Hz, 110/220V
FLX-2674-60	FLX-2674-60R	DDPU, 250 RPM, 3/4 HP, 1 PH, 60 Hz, 115/230V
FLX-3589-50	FLX-3589-50R	DDPU, 368 RPM, 1/3 HP, 1 PH, 50 Hz, 115/230V
FLX-3589-60	FLX-3589-60R	DDPU, 441 RPM, 1/3 HP, 1 PH, 60 Hz, 115/230V
FLX-3590-50	FLX-3590-50R	DDPU, 368 RPM, 1/2 HP, 1 PH, 50 Hz, 115/230V
FLX-3590-60	FLX-3590-60R	DDPU, 441 RPM, 1/2 HP, 1 PH, 60 Hz, 115/230V
FLX-3591-50	FLX-3591-50R	DDPU, 368 RPM, 3/4 HP, 1 PH, 50 Hz, 110/220V
FLX-3591-60	FLX-3591-60R	DDPU, 441 RPM, 3/4 HP, 1 PH, 60 Hz, 115/230V
FLX-3603	FLX-3603R	DDPU, 441/364 RPM, 3/4 HP, 3 PH, 50/60 Hz, 190/380V
FLX-3631	FLX-3631R	DDPU, 368 RPM, 1/3 HP, 3 PH, 50 Hz, 190/380V
FLX-3633	FLX-3633R	DDPU, 368 RPM, 3/4 HP, 3 PH, 50 Hz, 190/380V
FLX-3653	FLX-3653R	DDPU, 539 RPM, 1-1/2 HP, 3 PH, 60 Hz, 208-230/460V

Model 220 Unloader and Anchor Assembly

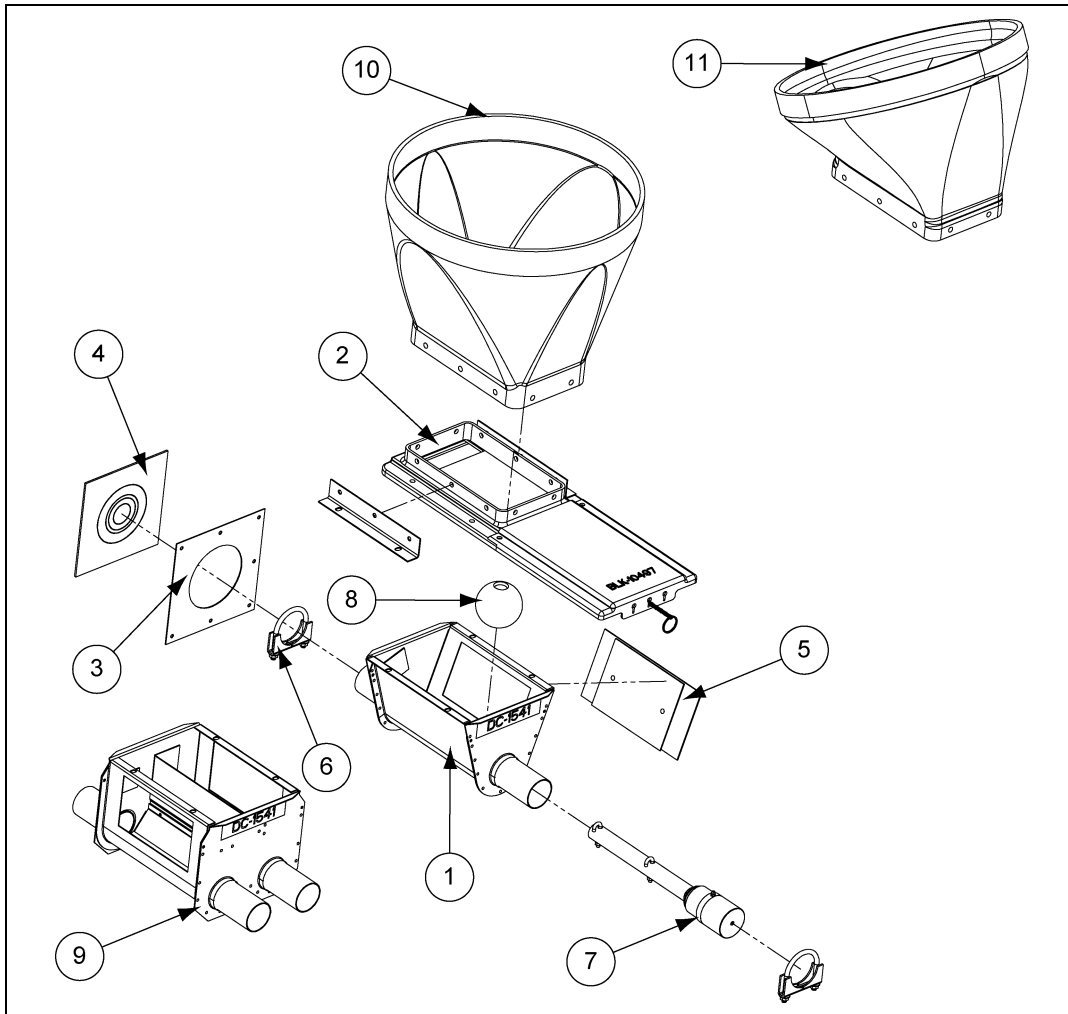

Ref #	Part #	Description	Qty
1	FLX-4331	Model 220 Flex-Flo Single through Unloader Body Assembly	1
2	BLK-11137A	Transfer and Slide Gate Kit	1
3	FLX-2217	Model 220, 300, 350 Flex Seal Ring	1
4	FLX-3422	Neoprene Seal	1
5	FLX-4239	Clean-Out Plate Assembly	1
6	S-4490	2-1/4" Tube Clamp Model 220	2
7	FLX-4646	Model 220/EP Anchor and Bearing Assembly	1
8	00404238	Iron Ball 3" Hollow - 1-1/2 #	1
9	FLX-3938	Model 220 Flex-Flo Twin Unloader Body Assembly	1
10	FLX-2195	16" Straight Black Plastic Boot	1
10	FLX-2195C	16" Straight Clear Plastic Boot	1
11	FLX-2194	16" 30° Black Plastic Boot	1
11	FLX-2194C	16" 30° Clear Plastic Boot	1

Model 300, 350 and HR Unloader and Anchor Assembly

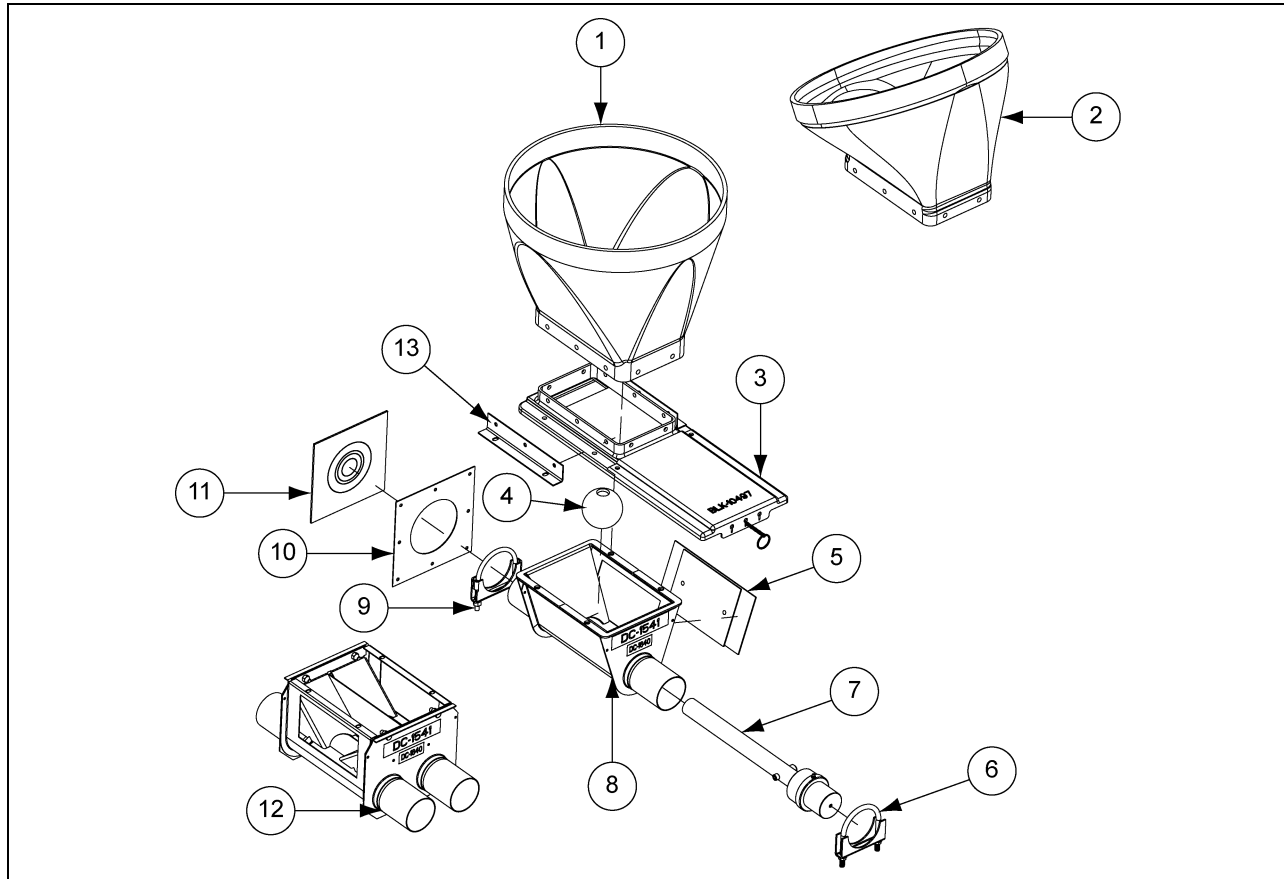

Ref #	Model 300		Model 350	
	Part #	Description	Part #	Description
1	FLX-2195	16" Straight Black Plastic Boot	FLX-2195	16" Straight Black Plastic Boot
1	FLX-2195C	16" Straight Clear Plastic Boot	FLX-2195C	16" Straight Clear Plastic Boot
2	FLX-2194	16" 30° Black Plastic Boot	FLX-2194	16" 30° Black Plastic Boot
2	FLX-2194C	16" 30° Clear Plastic Boot	FLX-2194C	16" 30° Clear Plastic Boot
N/S	FLX-4869	16" Double Straight Black Boot	FLX-4869	16" Double Straight Black Boot
3	BLK-11137A	Transfer and Slide Gate Kit	BLK-11137A	Transfer and Slide Gate Kit
4	00404238	Iron Ball 3" Hollow - 1-1/2 #	00404238	Iron Ball 3" Hollow - 1-1/2 #
5	FLX-4239	Clean-Out Plate Assembly	FLX-4239	Clean-Out Plate Assembly
6	S-4320	3" Tube Clamp	S-4319	3-1/2" Tube Clamp
7	FLX-4648	Model 300 Anchor and Bearing Assembly	FLX-4650	Model 350 Anchor and Bearing Assembly
8	FLX-4669	Model 300 Flex-Flo Single through Unloader Body Assembly	FLX-2053	Model 350 Flex-Flo Single through Unloader Body Assembly
9	S-9186	3-1/4" Tube Clamp Model 300	S-4443	4" Tube Clamp Model 350
10	FLX-2217	Model 220, 300, 350 Flex Seal Ring	FLX-2217	Model 220, 300, 350 Flex Seal Ring
11	FLX-3422	Neoprene Seal	FLX-3422	Neoprene Seal
12	FLX-4671B	Model 300 Flex-Flo Twin through Unloader Body Assembly	FLX-2116B	Model 350 Flex-Flo Twin through Unloader Body Assembly
13	FLX-4819	Unloader Brace	FLX-4819	Unloader Brace

Model 500 Unloader and Anchor Assembly

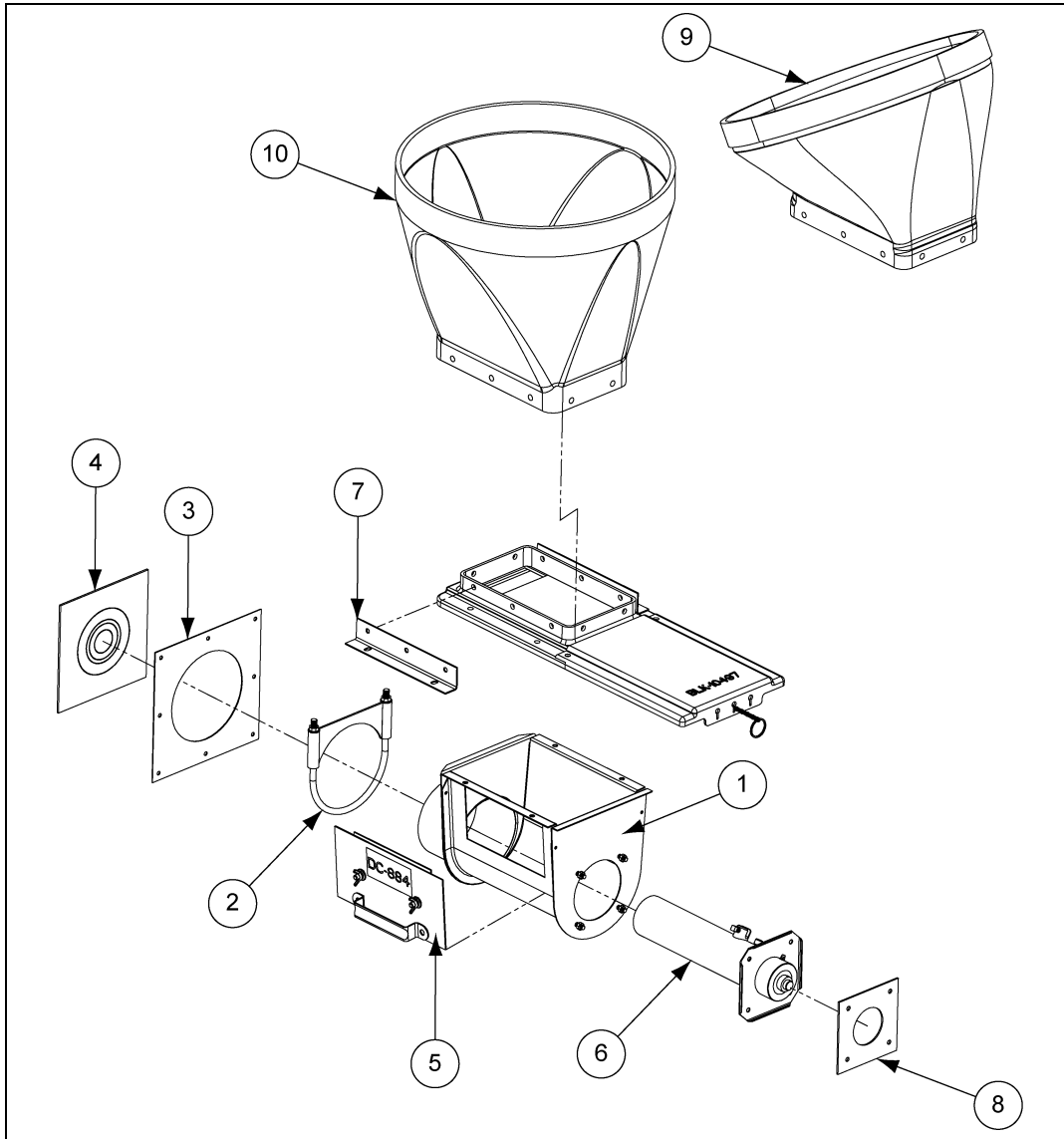

Ref #	Part #	Description	Qty
1	FLX-2065	Model 500 Flex-Flo Single through Unloader Body Assembly	1
2	S-4494	5-1/2" Tube Clamp Model 500	1
3	FLX-2218	Model 500 Flex Seal Ring	1
4	FLX-3422	Neoprene Seal	1
5	FLX-4239	Clean-Out Plate Assembly	1
6	FLX-2192	Model 500 Anchor and Bearing Assembly	1
7	BLK-11137A	Transfer and Slide Gate Kit	1
8	FLX-2095	4"-5" Control Unit Seal	1
9	FLX-2194	16" 30° Black Plastic Boot	1
9	FLX-2194C	16" 30° Clear Plastic Boot	1
10	FLX-2195	16" Straight Black Plastic Boot	1
10	FLX-2195C	16" Straight Clear Plastic Boot	1

Direct Drive and Tube Anchor

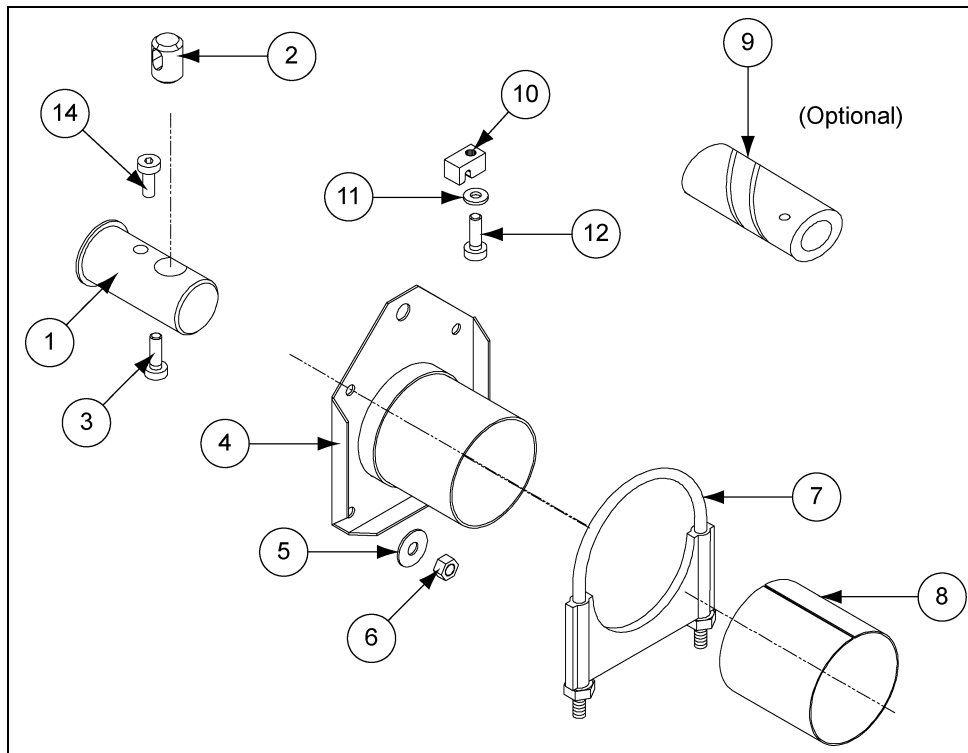

Ref #	Part #	Description
	FLX-2699	220 D.D. Driver and Tube Anchor
	FLX-2696	300 D.D. Driver and Tube Anchor
	FLX-2697	350 D.D. Driver and Tube Anchor
	FLX-2698	500 D.D. Driver and Tube Anchor
1	FLX-4572	Model 300 Direct Drive Spindle
1	FLX-4575	Model 350 Direct Drive Spindle
1	FLX-2975	Model 500 Belt and Direct Drive Spindle
2	FLX-4571	Model 300/350 Auger Lock Clamp Pin
2	FLX-2974	Model 500 Auger Lock Clamp Pin
3	S-6481	5/16"-18 x 1-1/2" Hex Socket Cap Screw Model 300 and 350
3	S-6483	5/16"-18 x 2-1/2" Hex Socket Cap Screw Model 500
4	FLX-2316	Model 220 Tube Anchor Plate
4	FLX-2317	Model 300 Tube Anchor Plate
4	FLX-2318	Model 350 Tube Anchor Plate
4	FLX-2319	Model 500 Tube Anchor Plate
5	S-845	Flat Washer 5/16" USS SAE YDP Grade 2
6	S-396	1/4"-20 Hex Nut
7	S-4490	2-1/4" Tube Clamp Model 220
7	S-9186	3-1/4" Tube Clamp Model 300
7	S-4443	4" Tube Clamp Model 350
7	S-4494	5-1/2" Tube Clamp Model 500
8	FLX-2634	Model 300 Tube Spacer
9	FLXDF-1183	Drop Feed Control Anchor Package
10	FLX-4543	Auger Lock 220 Direct Drive
11	FLX-2685	Model 220 Direct Drive Anchor Washer
12	S-8039	Bolt, 1/4"-20 x 1-1/4" Socket Head

Belt Drive and Tube Anchor

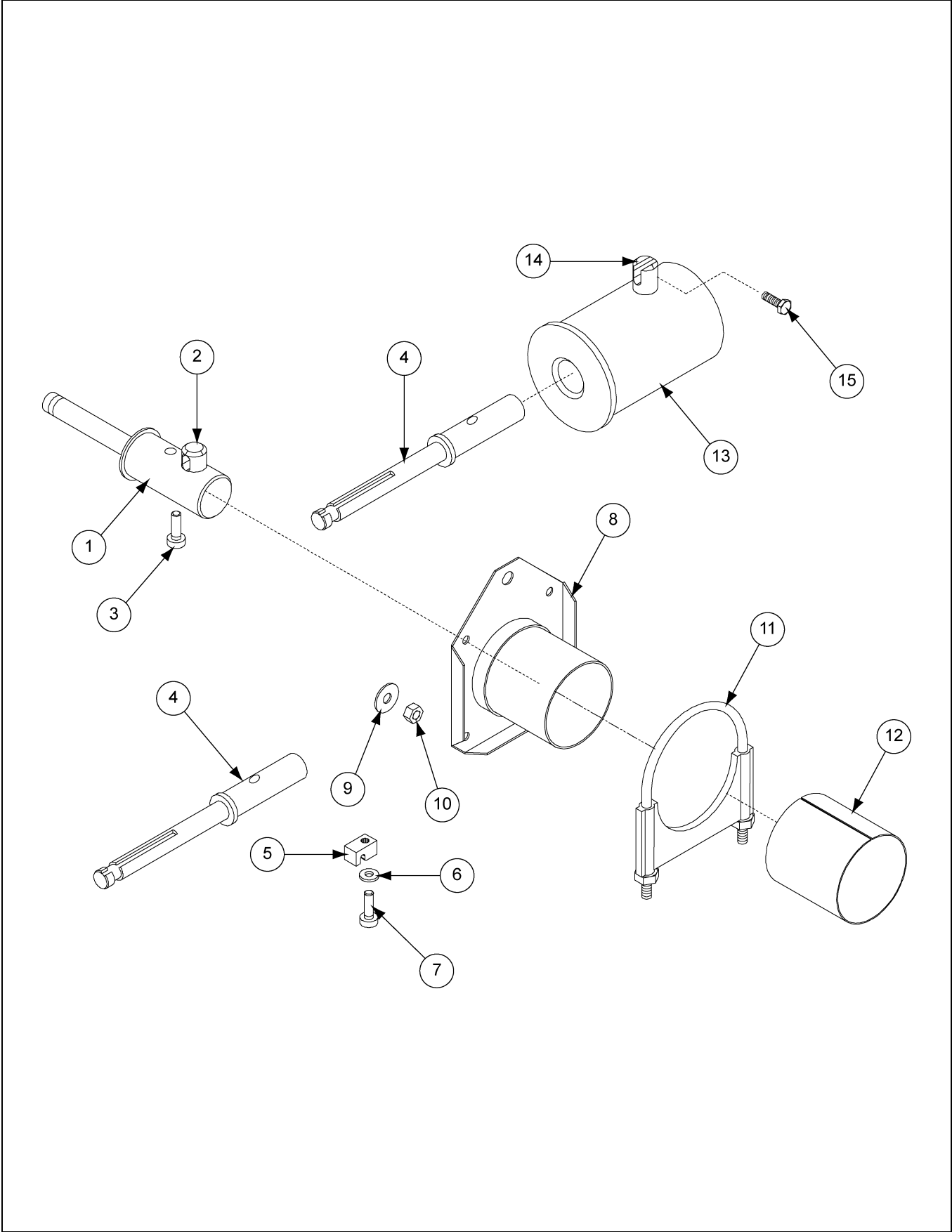

Belt Drive and Tube Anchor Parts List

Ref #	Part #	Description
	FLX-2695	220 B.D. Driver and Tube Anchor
	FLX-2692	300 B.D. Driver and Tube Anchor
	FLX-2693	350 B.D. Driver and Tube Anchor
	FLX-2694	500 B.D. Driver and Tube Anchor
1	FLX-4578	Model 300 Belt Driver
1	FLX-4579	Model 350 Belt Driver
2	FLX-4571	Model 300/350 Auger Lock Clamp Pin
3	S-6481	Bolt, SHCS 5/16"-18 x 1-1/2" Model 300
3	S-6482	Bolt, SHCS 5/16"-18 x 1-3/4" Type B Cup Point Model 350
4	FLX-2979	Model 220 and 500 Belt Driver
5	FLX-4543	Auger Lock 220 Belt Drive
6	S-845	Flat Washer 5/16" USS SAE YDP Grade 2
7	S-8039	Bolt, 1/4"-20 x 1-1/4" Socket Head
8	FLX-2316	Model 220 Tube Anchor Plate
8	FLX-2317	Model 300 Tube Anchor Plate
8	FLX-2318	Model 350 Tube Anchor Plate
8	FLX-2319	Model 500 Tube Anchor Plate
9	S-845	Flat Washer 5/16" USS SAE YDP Grade 2
10	S-396	Hex Nut 5/16"-18 YDP Grade 2
11	S-4490	2-1/4" Tube Clamp Model 220
11	S-9186	3-1/4" Tube Clamp Model 300
11	S-4443	4" Tube Clamp Model 350
11	S-4494	5-1/2" Tube Clamp Model 500
12	FLX-2634	Model 300 Tube Spacer
13	FLX-2975	Model 500 Belt and Direct Drive Spindle
14	FLX-2974	Model 500 Auger Lock Clamp Pin
15	S-4312	Set Screw 5/16"-18 x 1/2" Square Head BK Cup Point

6. Parts List

Model 220, 300 and 350 Control Unit (FLX-4496)

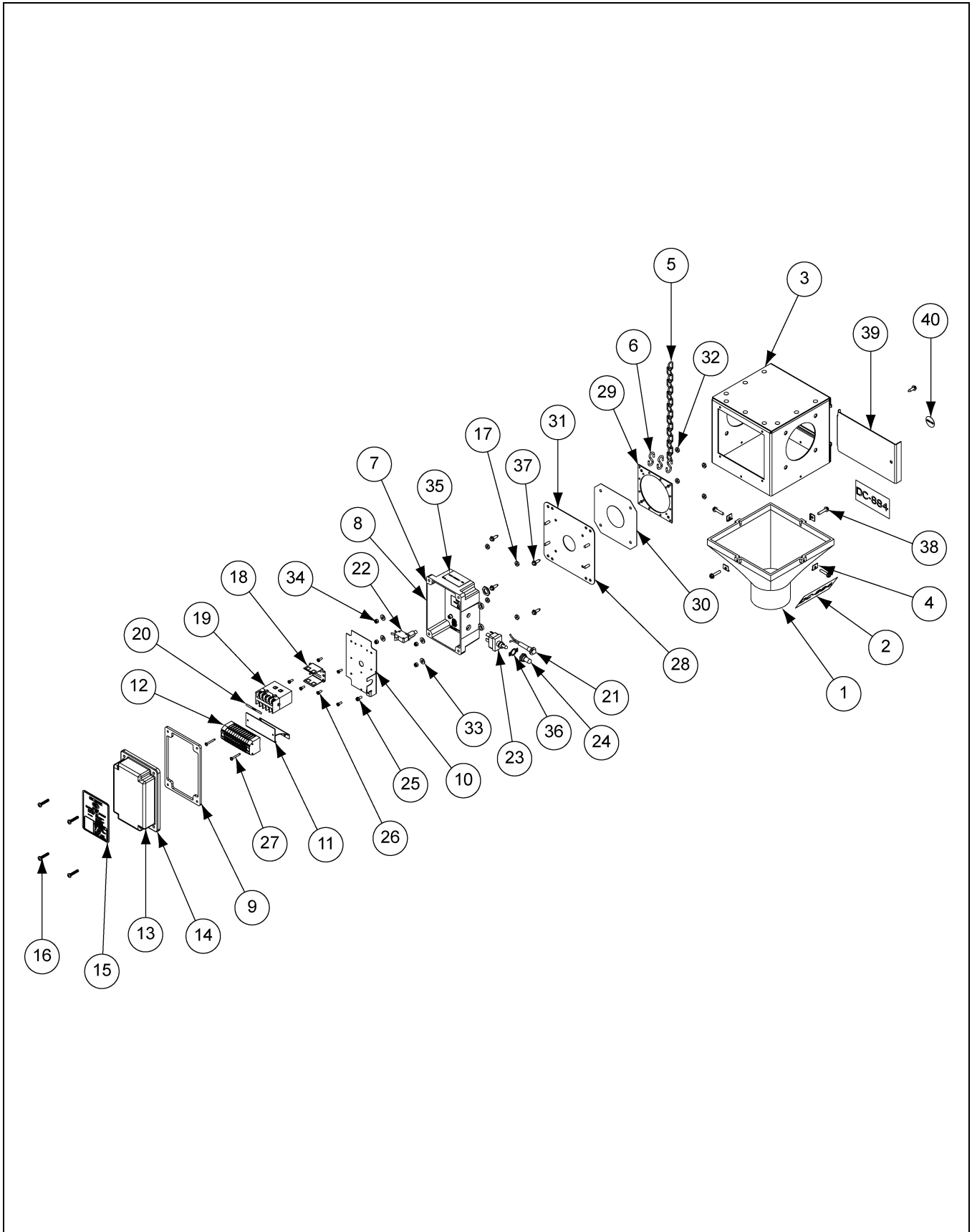

Model 220, 300 and 350 Control Unit (FLX-4496) Parts List

Ref #	Part #	Description	Qty
1	FLX-2017	Powerhead Drop	1
2	DC-884	Decal, Rotating Auger Hazard	2
3	FLX-4260	Model 220, 300, 350 Control Unit Body	1
4	AP-2213	Retaining Clip	4
5	S-4694	Chain #2 Weldless	1
6	S-3383	Hook #41 S-Hook 1-1/2" Long	3
7	FLX-5015-LB	Flex-Flo Control Unit	1
8	FLX-4516	Electrical Box Bottom Drilled	1
9	FLX-4561	4 x 6 Electrical Box Gasket	1
10	FLX-4569	Back Plate, 4 x 6 Control Box	1
11	FLX-5017	Bracket, Terminal Block Mounting	1
12	FLX-5040	Terminal Block Assembly for Flex-Flo Control Unit	1
13	FLX-4517	Electrical Box Lid w/ Decal	1
14	FLX-4560	Electrical Box Lid 4 x 6	1
15	DC-2117	Decal, Flex-Flo Control 220V	1
16	S-995	Screw, MS #10-24 x 1" SS	4
17	S-7931	Hex Nut #10-24 SS	4
18	FLX-4620	Relay, Bracket f/ FLX-4619	1
19	FLX-4619	Relay, 4 Pole, ST, N.O., 240V	1
20	DC-1515	Decal, 208V/230V 3 PH Wire Label	1
21	S-7604	Light 250V Sealed Red Pilot	1
22	S-7707	Safety Limit Switch	1
23	S-6142	Switch, DPST ON-OFF Toggle	1
24	70-0129	Boot Switch Weather-Proof	1
25	S-8823	Screw, TCS23 #8-32 x 3/8" HWHS ZN Green	1
26	S-8183	Screw, MS #6-32 x 3/8" PHP ZN	6
27	S-8686	Screw, TCSF #6-32 x 3/8" PHP ZN	2
28	FLX-4522	Control Unit Base Assembly	1
29	FLX-2380	Small Diaphragm Retainer	1
30	FLX-4410	Diaphragm Assembly	1
31	FLX-4510	Control Unit Base - Sealed	1
32	S-849	Hex Nut #10-24 ZN Grade 2	4
33	S-3674	Flat Washer #10 x 7/32" I.D. x 1/2" O.D. x 18 Gauge SAE ZN Grade 2	4
34	S-2010	Nylock Nut #10-24 ZN Grade 2	4
35	DC-2124	Decal, ETL/Intertek Mark	1
36	S-6622	ON-OFF Back Plate	1
37	S-280	Screw, SDS #10-16 x 5/8" HWH ZN	5
38	S-7621	Screw, TCSF #10-32 HWH ZN 3/4"	4
39	FLX-4261	Control Box Access Door	1
40	DC-850	Decal, European Certification	1

Flex-Flo Control Unit (FLX-5015)

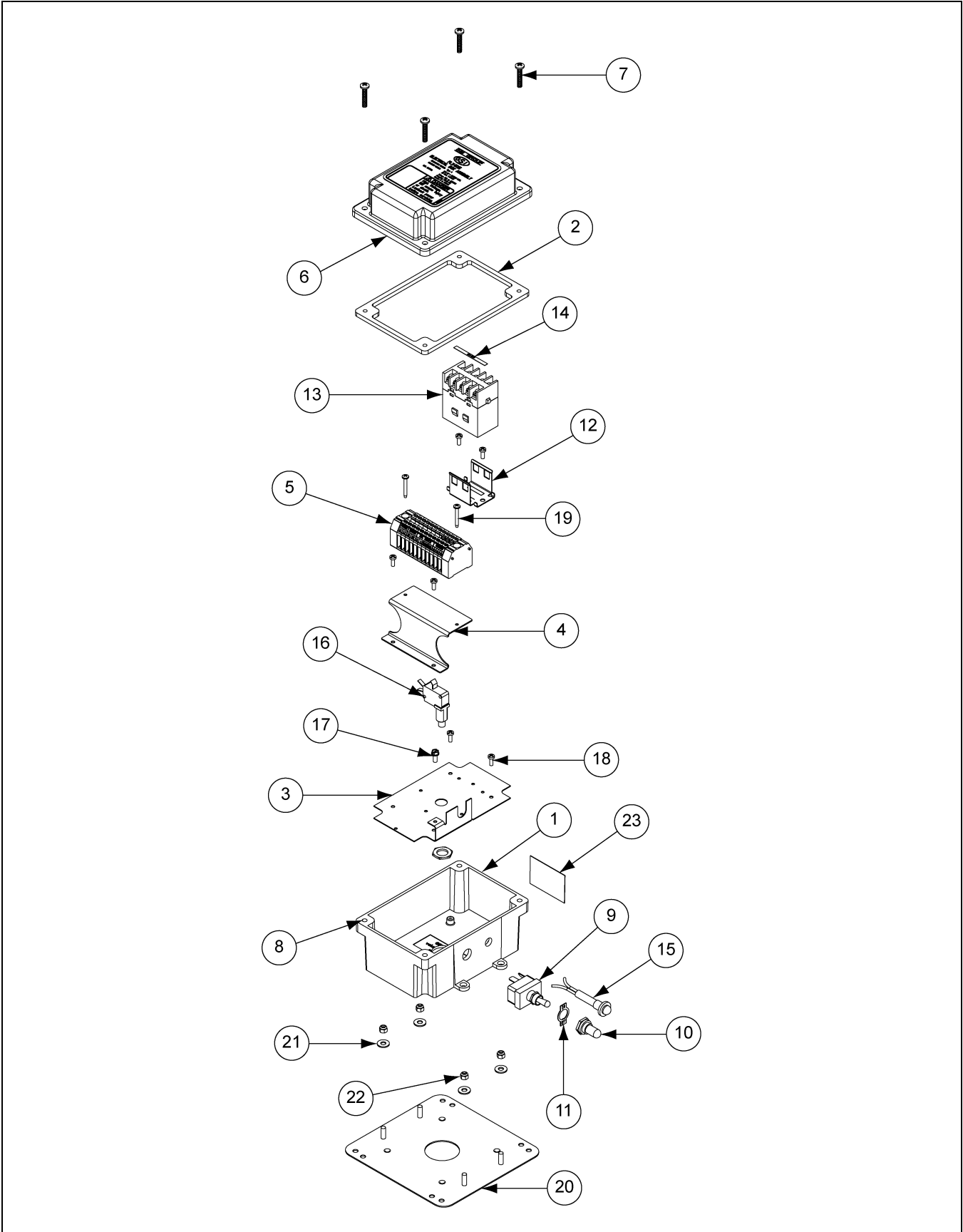

Flex-Flo Control Unit (FLX-5015) Parts List

Ref #	Part #	Description	Qty
1	FLX-4516	Electrical Box Bottom Drilled	1
2	FLX-4561	4 x 6 Electrical Box Gasket	1
3	FLX-4569	Back Plate, 4 x 6 Control Box	1
4	FLX-5017	Bracket, Terminal Block Mounting	1
5	FLX-5040	Terminal Block Assembly for Flex-Flo Control Unit	1
6	FLX-4517	Electrical Box Lid w/ Decal	1
7	S-995	Screw, MS #10-24 x 1" SS	4
8	S-7931	Hex Nut #10-24 SS	4
9	S-6142	Switch, DPST ON-OFF Toggle	1
10	70-0129	Boot Switch Weather-Proof	1
11	S-6622	ON-OFF Back Plate	1
12	FLX-4620	Relay, Bracket f/ FLX-4619	1
13	FLX-4619	Relay, 4 Pole, ST, N.O., 240V	1
14	DC-1515	Decal, 208V/230V 3 PH Wire Label	1
15	S-7604	Light 250V Sealed Red Pilot	1
16	S-7707	Safety Limit Switch	1
17	S-8823	Screw, TCS23 #8-32 x 3/8" HWHS ZN Green	1
18	S-8183	Screw, MS #6-32 x 3/8" PHP ZN	6
19	S-8686	Screw, TCSF #6-32 x 3/8" PHP ZN	2
20	FLX-4522	Control Unit Base Assembly	1
21	S-3674	Flat Washer #10 x 7/32" I.D. x 1/2 O.D. x 18 Gauge SAE ZN Grade 2	4
22	S-2010	Nylock Nut #10-24 ZN Grade 2	4
23	DC-2124	Decal, ETL/Intertek Mark	1

Belt Drive Power Unit

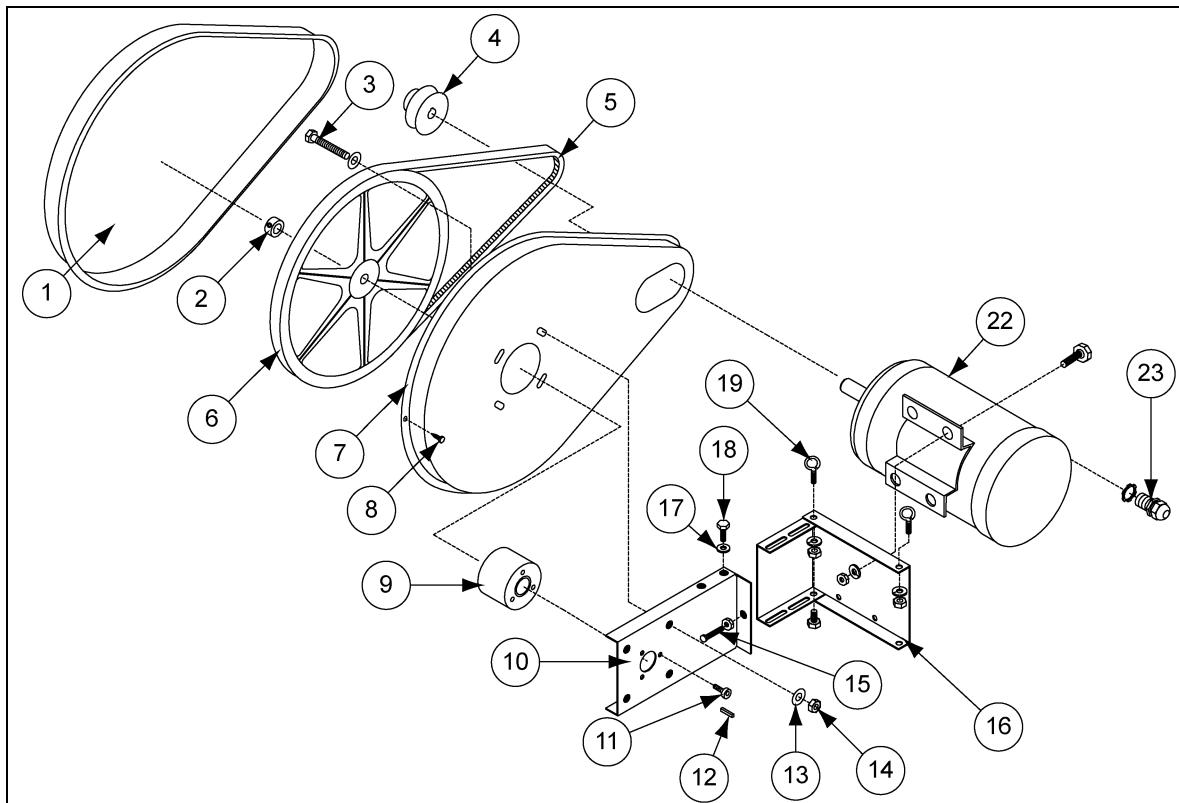

Ref #	Part #	Description
	FLX-4179	14" Belt Drive Power Unit (Less Motor)
1	FLX-2986	Belt Guard Cover
2	S-4307	5/8" I.D. Locking Collar
3	S-7149	Bolt, HHTB 5/16"-18 x 1-3/4" ZN Grade 5
4	S-6242	2.7" A-Belt Single Groove Pulley (5/8" Bore)
5	BLK-11086	AX51 Gripnotch Belt
6	S-6240	14" A-Belt Single Groove Pulley
7	FLX-2987	Belt Guard Back
8	S-280	Screw, SDS #10-16 x 5/8" HWH ZN
9	FLX-2734S	Flex-Flo Anchor Bearing Assembly with Set Screw
10	FLX-5043	Inner Belt Drive Motor Bracket
11	S-4309	1/4"-20 x 5/8" Allen Head Bolt
12	S-8426	Square Key 3/16" x 1" Long
13	S-845	Flat Washer 5/16" USS SAE YDP Grade 2
14	S-396	Hex Nut 5/16"-18 YDP Grade 2
15	S-7299	Bolt, HHTB 5/16"-18 x 2-1/2" ZN Grade 2
16	FLX-5042	Outer Belt Drive Motor Bracket
17	S-1147	Split Lock Washer 5/16" ZN
18	S-4275	Bolt, HHTB 5/16"-18 x 3/4" ZN Grade 5
19	S-6236	Eye Bolt 5/16"-18 x 2-1/8" (w/ Nut)
22	013-1	Motor, 1/3 HP, 1 PH, 110/220V, 60 Hz, Farm Duty (5/8" Shaft)
22	012-1	Motor, 1/2 HP, 1 PH, 110/220V, 60 Hz, Farm Duty (5/8" Shaft)
22	034-1	Motor, 3/4 HP, 1 PH, 110/220V, 60 Hz, Farm Duty (5/8" Shaft)
22	100-1	Motor, 1 HP, 1 PH, 60 Hz, 110/220V, 1750 RPM (5/8" Shaft)
22	112-1	Motor, 1-1/2 HP, 1 PH, 60 Hz, 110/220V, 1750 RPM (5/8" Shaft)
23	S-6381	Black Strain Relief

Direct Drive Power Unit

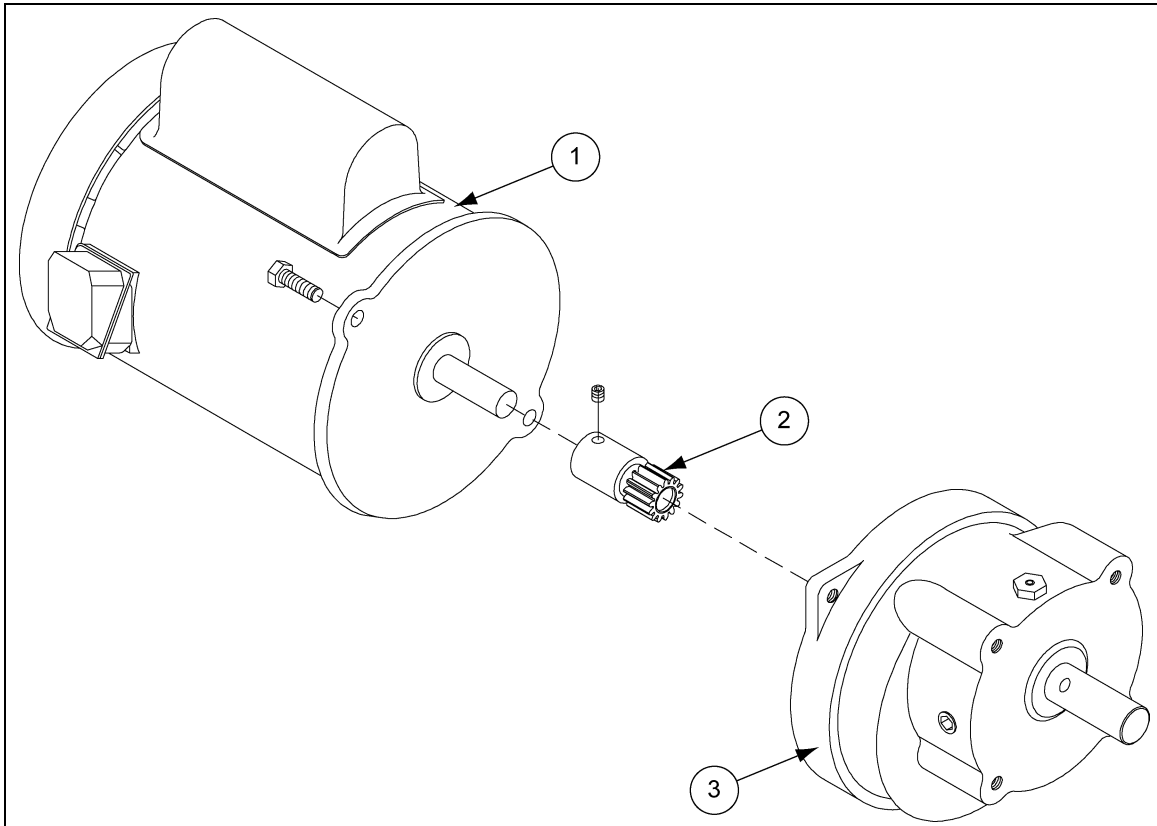

Ref #	Part #	Description
1	FLX-4763	Motor, 1/3 HP, 1 PH, 60 Hz, 115/230V, 1725 RPM
1	FLX-4764	Motor, 1/2 HP, 1 PH, 60 Hz, 115/230V, 1725 RPM
1	FLX-4765	Motor, 3/4 HP, 1 PH, 60 Hz, 115/230V, 1725 RPM
1	FLX-4766	Motor, 1 HP, 1 PH, 60 Hz, 115/230V, 1725 RPM
1	FLX-2473	Motor, 1-1/2 HP, 1 PH, 60 Hz, 115/230V, 1725 RPM
2	FLX-4275	Pinion Gear for Gear Reducer, 1/3, 1/2 and 3/4 HP
2	FLX-4276	Pinion Gear for Gear Reducer, 1 and 1-1/2 HP
2	FLX-4542	Pinion Gear for Gear Reducer 1 or 1-1/2 HP
2	FLX-2983	Pinion Gear for Gear Reducer, 1/3 HP
2	FLX-2973	Gear Reducer Pinion Gear 1 HP
3	FLX-4277(R) *	Gearbox, 358 RPM w/o Pinion Gear
3	FLX-4400(R) *	Gearbox, 156 RPM w/o Pinion Gear
3	FLX-4403(R) *	Gearbox, 250 RPM w/o Pinion Gear
3	FLX-4405(R) *	Gearbox, 441 RPM w/o Pinion Gear
3	FLX-4406(R) *	Gearbox, 539 RPM w/o Pinion Gear
N/S	FLX-4358	Adapter Plate Aluminum C-Face
N/S	FLX-4407	1 Phase P.U. Oil and Hardware

* **NOTE:** To order a gearbox with the opposite orientation (rotated 180°), add an "R" to the end of these part numbers.

6. Parts List

Drop Kit/Kwik-Attach Drop Kit

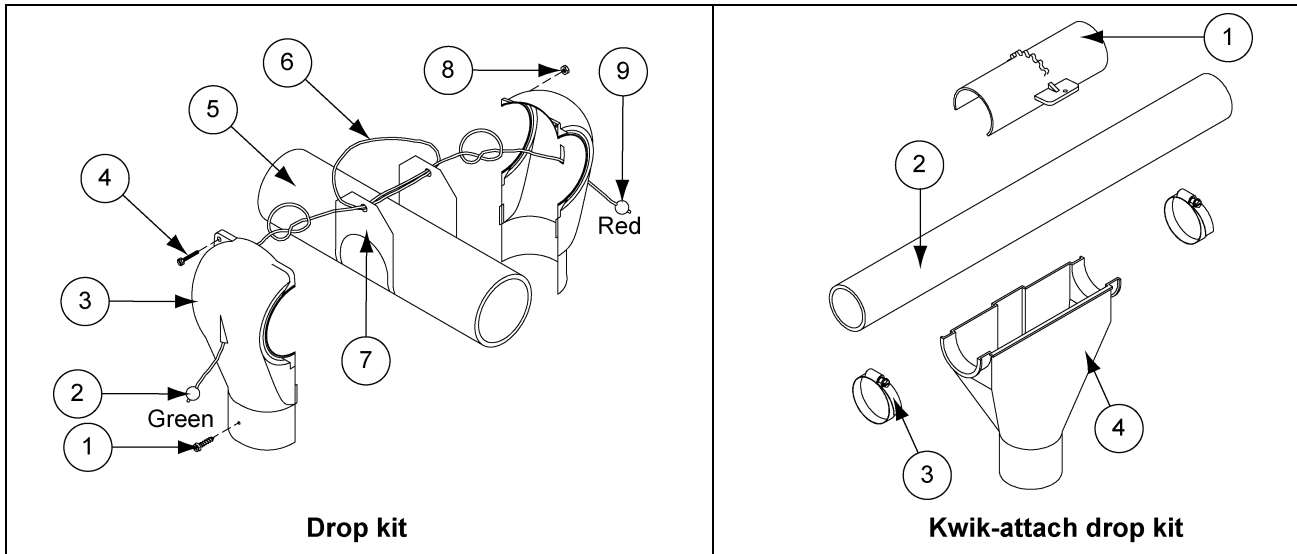

Drop Kit Parts List

Ref #	Part #	Description
	FLX-2432	Model 220 Drop Kit (Nylon)
	FLX-2433	Model 300 Drop Kit (Nylon)
	FLX-2434	Model 350 Drop Kit (Nylon)
	FLX-2435	Model 500 Drop Kit (Nylon)
1	S-280	Screw, SDS #10-16 x 5/8" HWH ZN
2	FLX-2441	Green Indicator Ball
3	FLX-220	Model 220 Drop Half
3	FLX-300	Model 300 Drop Half
3	FLX-350	Model 350 Drop Half
3	FLX-500	Model 500 Drop Half
4	S-8174	Screw, MS #10-24 x 5/8" HWHS SS
5		Model 220, 300, 350, 500 10' Straight Tube
6	CW-2008	#4 Solid Braided Utility Cord
7	FLX-2437	Model 220 Nylon Slide
7	FLX-2438	Model 300 Nylon Slide
7	FLX-2439	Model 350 Nylon Slide
7	FLX-2440	Model 500 Nylon Slide
8	S-7931	Hex Nut #10-24 SS
9	FLX-2442	Red Indicator Ball

Kwik-Attach Drop Kit Parts List

Ref #	Part #	Description
	APCD-109	Kwik-Attach Drop Kit for Model 220/236 (Single)
	AP-2276	Kwik-Attach Drop Kit for Model 300 (Single)
	APCD-110	Kwik-Attach Drop Kit for Model 220/236 (Box of 10)
	AP-2277	Kwik-Attach Drop Kit for Model 300 (Box of 10)
1	APCD-058	Shut Off Slide for Kwik-Attach Model 220
1	AP-1764	Kwik-Attach M300 Drop Kit Slide
2	PVC-1004	Model 220 PVC Flex-Flo Tube, 10' (3 Meters) w/ Belled End
2	PVC-1005	Model 300 PVC Flex-Flo Tube, 10' (3 Meters) w/ Belled End
3	AP-0583	Hose Clamp, Stainless Steel 1-3/4" - 2-3/4"
3	AP-0584	Hose Clamp, Stainless Steel 3"-4"
4	APCD-059	Main Housing for Kwik-Attach Model 220 Drop Kit
4	AP-1763	Main Housing for Kwik-Attach Model 300 Drop Kit

Unloader Switch

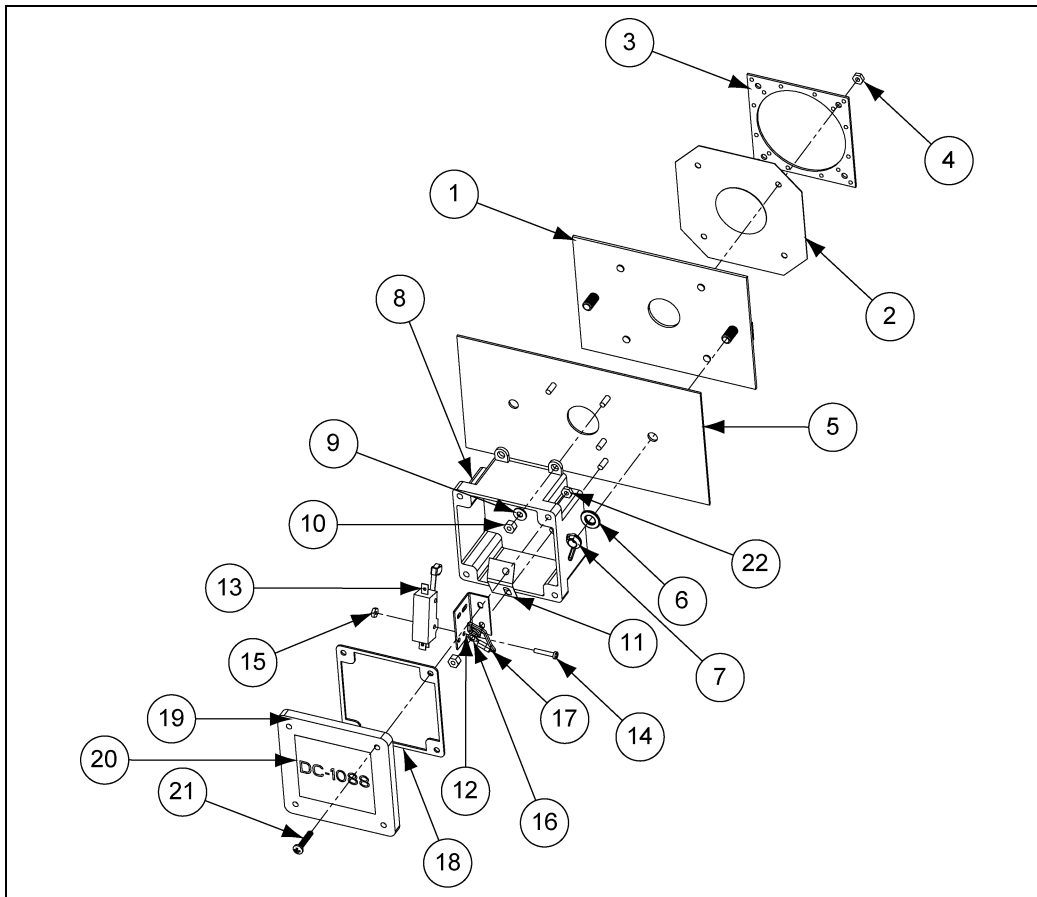

Ref #	Part #	Description	Qty
1	FLX-4157A	Back Plate, Unloader Switch Assembly	1
2	FLX-4410	Diaphragm Assembly	1
3	FLX-2380	Small Diaphragm Retainer	1
4	S-849	Hex Nut 10-24 Grade 2	1
5	FLX-4158A	Cover Plate Assembly for Switch	1
6	S-3558	3/8" Washer EPDM Steel Backed	1
7	S-4301	Wing Nut 5/16"-18 ZN Grade 2	1
8	FLX-4159	Unloader Switch Housing	1
9	S-3674	Flat Washer #10 x 7/32" I.D. x 1/2" O.D. x 18 Gauge TSAE ZN Grade 2	1
10	S-2010	Nylock Nut #10-24 ZN Grade 2	2
11	07097327	Micro Switch Spring Bracket	1
12	FLX-3493	Control Unit Switch Bracket	1
13	FLX-2128	Boot Switch	1
14	S-7319	Screw, MS #6-32 x 7/8" R.H. Side ZN Grade 2	1
15	S-6144	Hex Nut 6-32 Grade 2	1
16	E160-1074	Ring Terminal #10 Insulated	1
17	WR-16GRN-YLW	Wire 16 Gauge Green/Yellow Stranded 1'	1
18	FLX-2690	Electrical Box Gasket 4 x 4	1
19	FLX-2689	Electrical Box Lid	1
20	DC-1088	Decal, Flex-Flo Control Unit	1
21	S-995	Screw, MS #10-24 x 1" PHP SS	1
22	S-7931	Hex Nut #10-24 SS	1
23	BX-302	Box, 13-3/4" x 5-1/2" x 5-1/2" 200C FPF (Not Shown)	1

Micro Drop Tube Switch/Proximity Switch

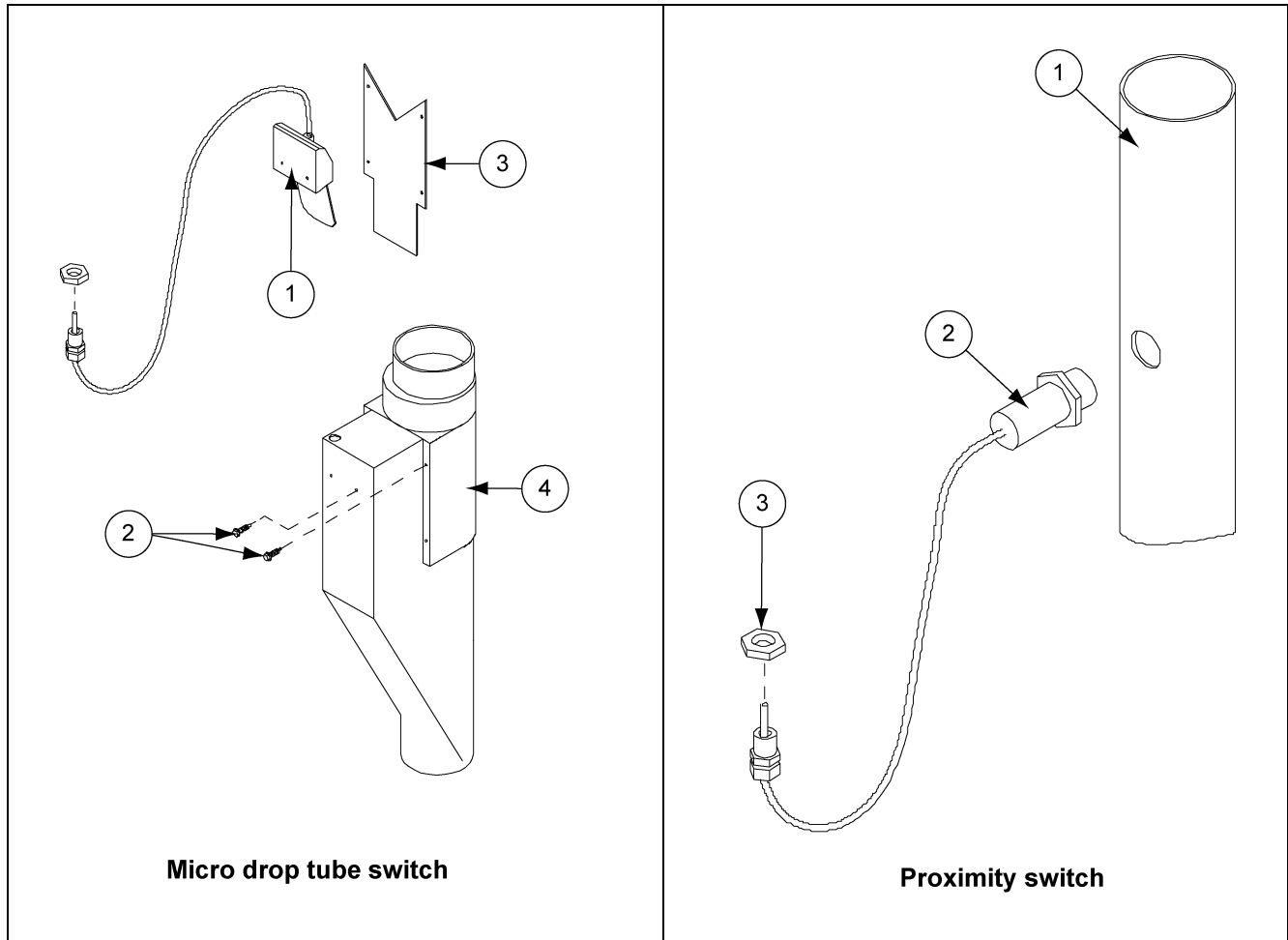

Micro Drop Tube Switch Parts List

Ref #	Part #	Description	Qty
	AP-0990	Plastic Drop Tube Switch, 110/220V	
1	FLX-3489	Micro Switch Box Assembly Wired N.C.	1
2	S-7621	Screw, SDS #10-16 x 1" HWH ZN Grade 2	6
3	FLX-3448	Drop Tube Switch Baffle Plate	1
4	FLX-3451	Drilled Drop Tube Housing	1

Proximity Switch Parts List

Ref #	Part #	Description	Qty
1	FLX-2425	Drop Tube, 3" I.D. x 12' (3.65 Meters)	1
2	FLXDF-1172	Capacitive Proximity Switch N.C. 20-250 VAC	1
3	S-7906	1/2" Cord Connector	1

FLX-4496 or FLX-5015 Factory Wiring Diagram

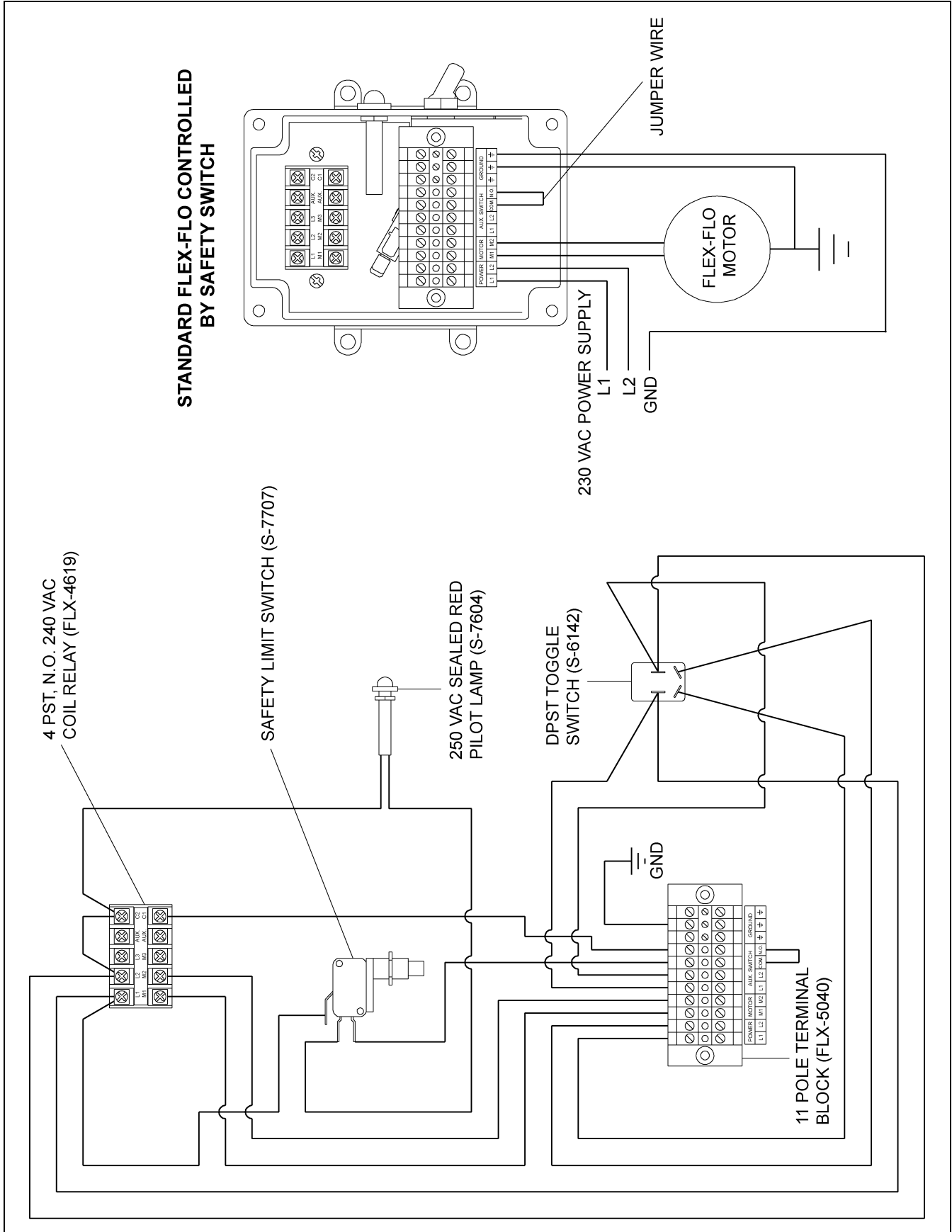

Wiring Diagram for Extension Flex-Flo Using Smart-Flex Control

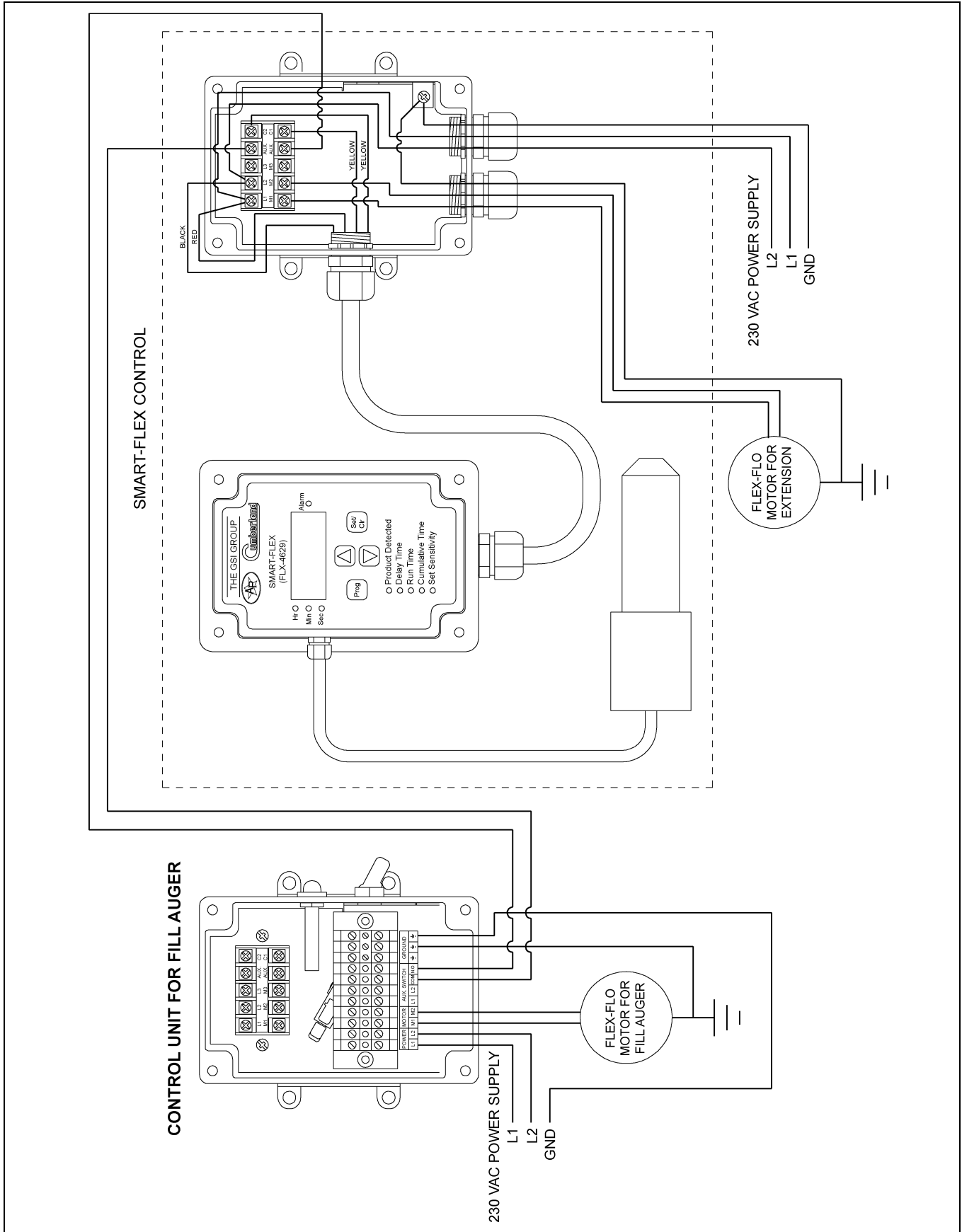

Wiring Diagram for Extension Flex-Flo Using Two (2) FLX-4496 Controls

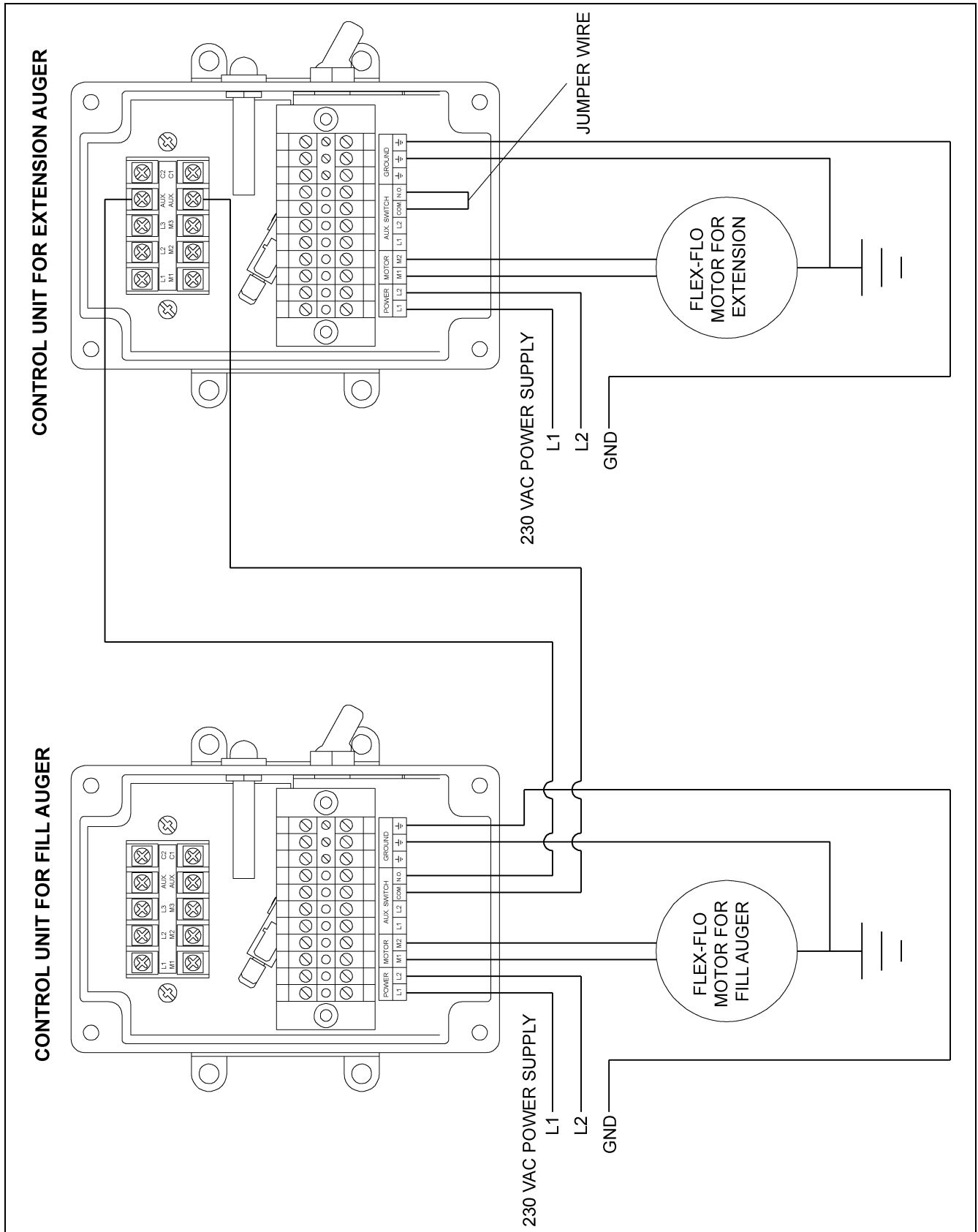

Flex-Flo Control with 220 Volt 24 Hour Time Clock

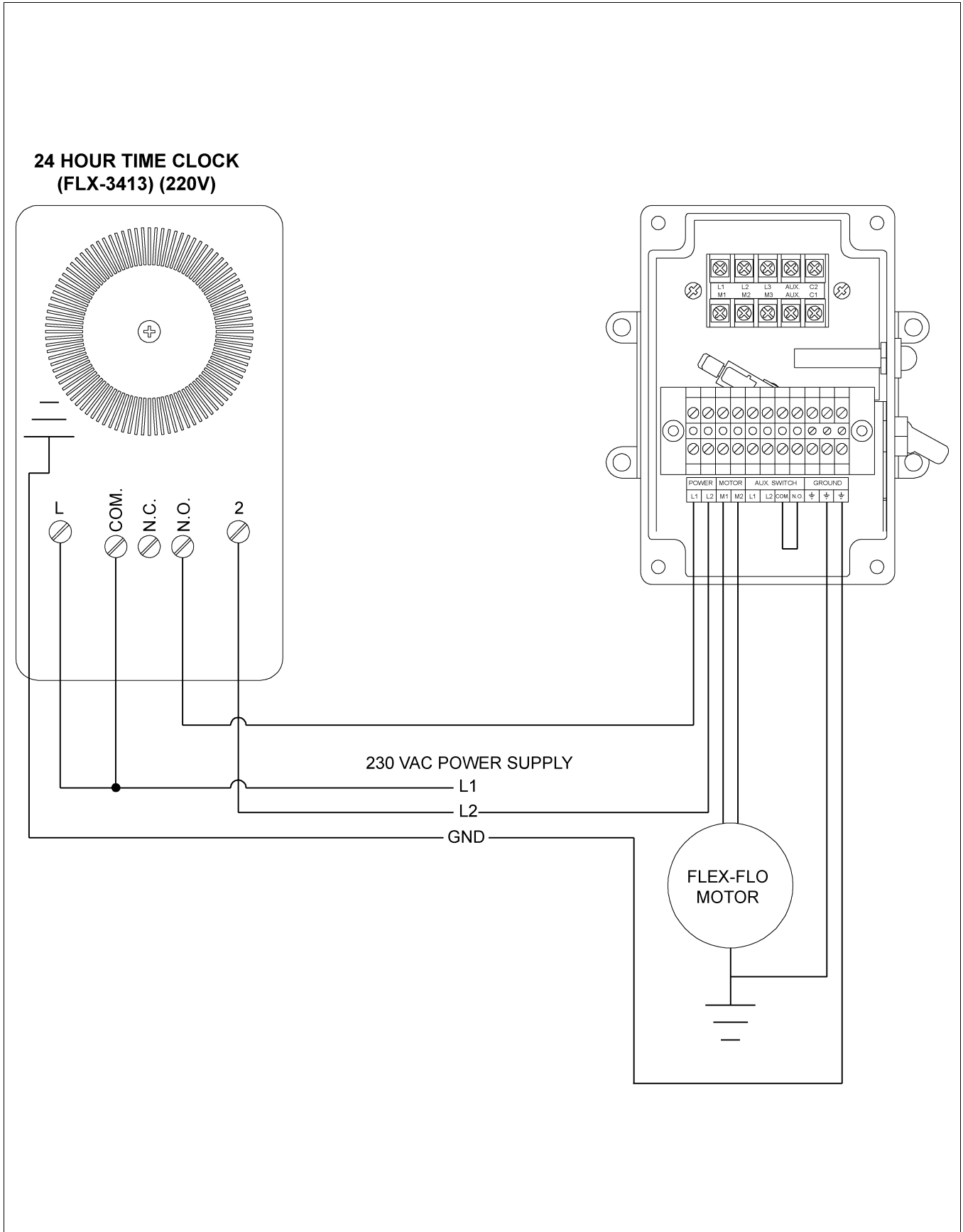

Flex-Flo Control with Proximity Switch (AP-1002)

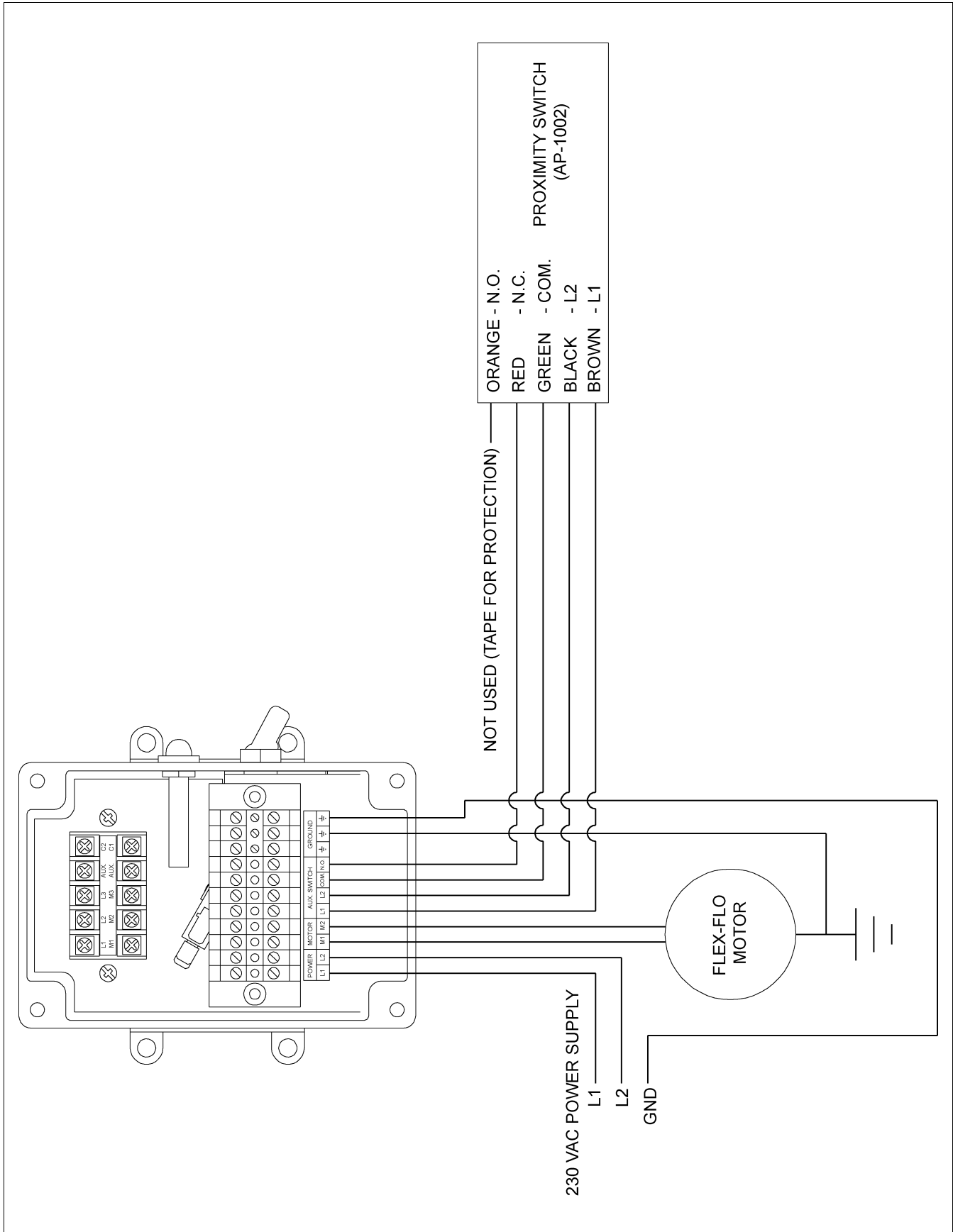

Flex-Flo Control with Proximity Switch (AP-2983)

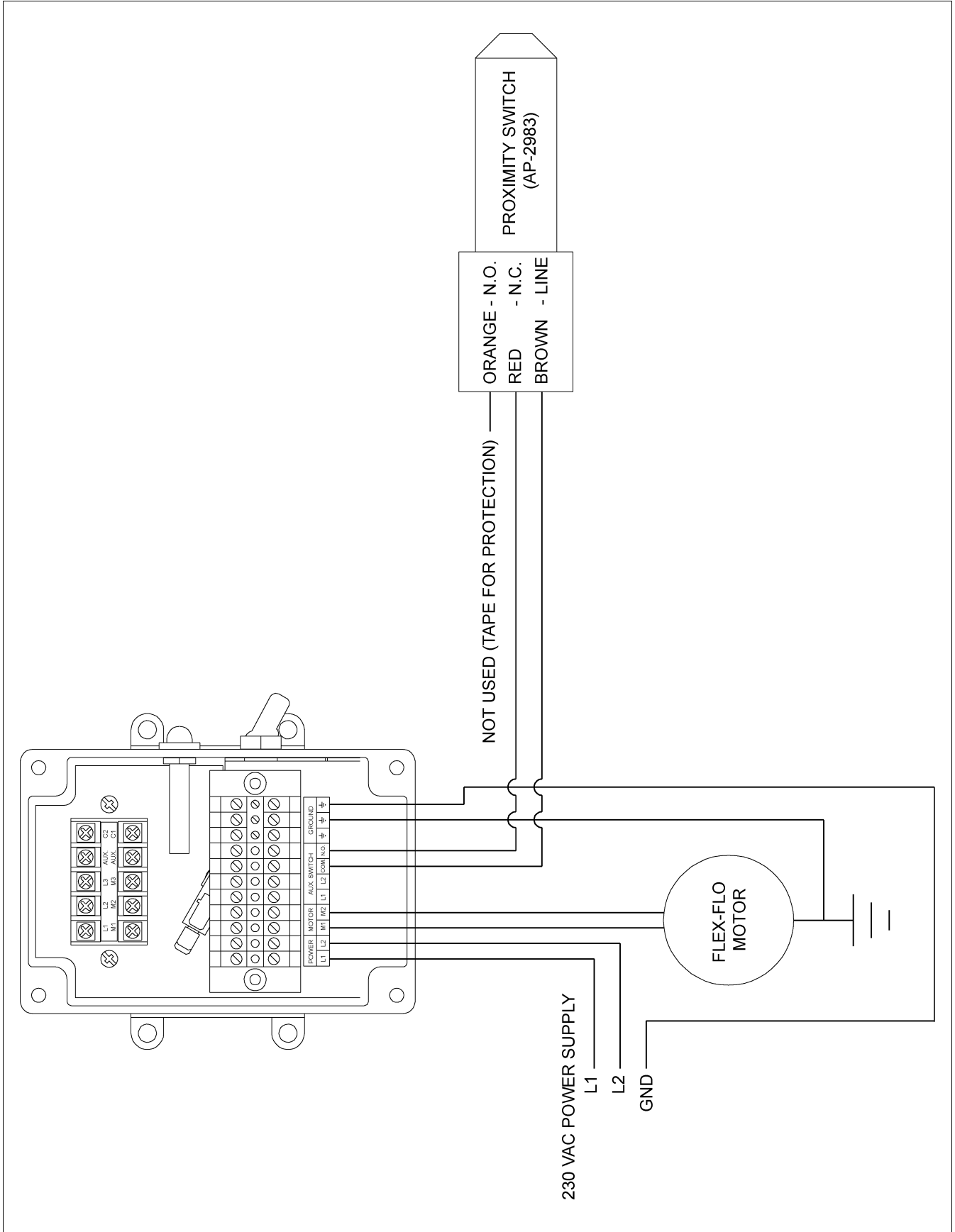

Flex-Flo Control with Drop Tube Switch or Hopper Level Switch

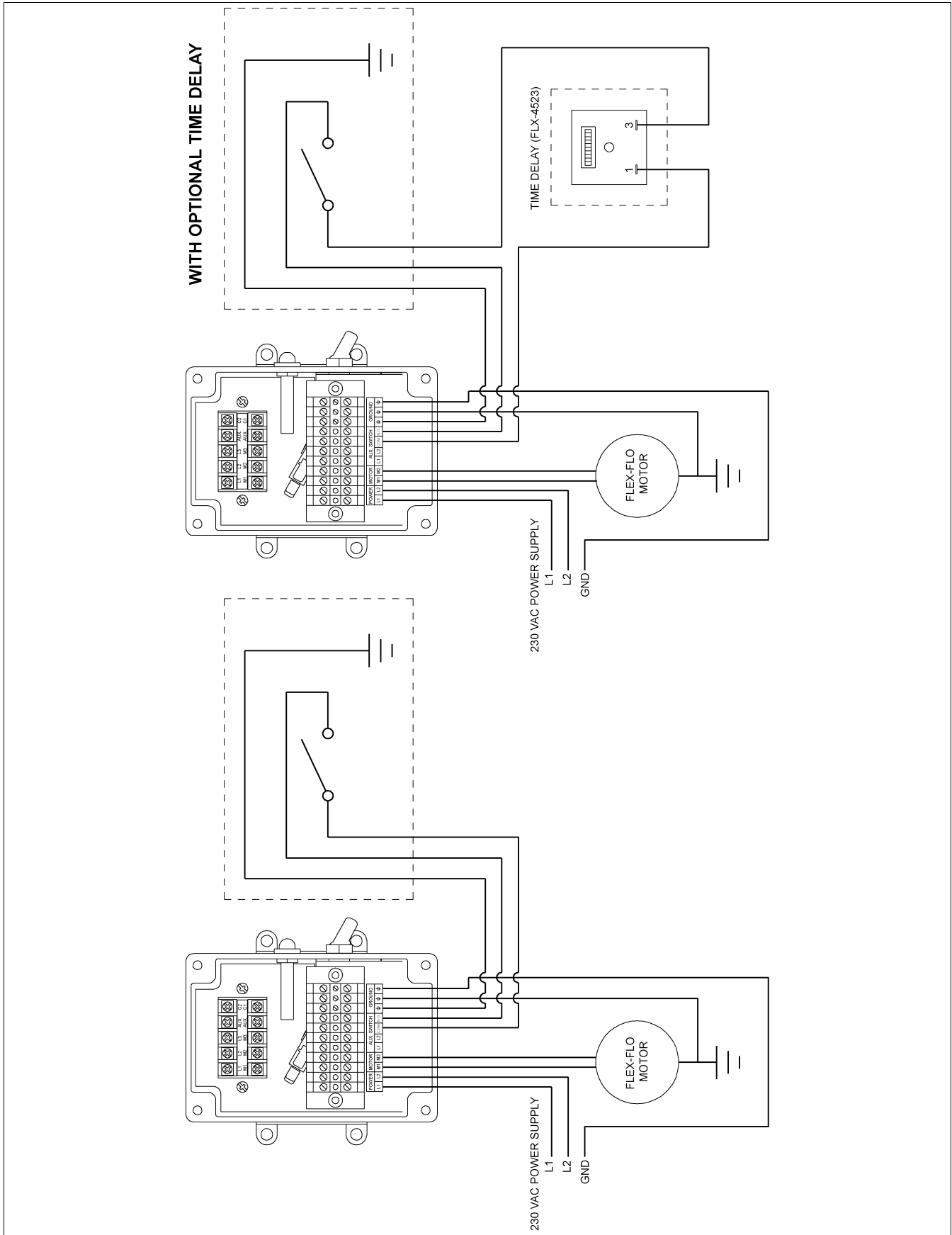

Flex-Flo Control with Smart IR Sensor (FLX-4951)

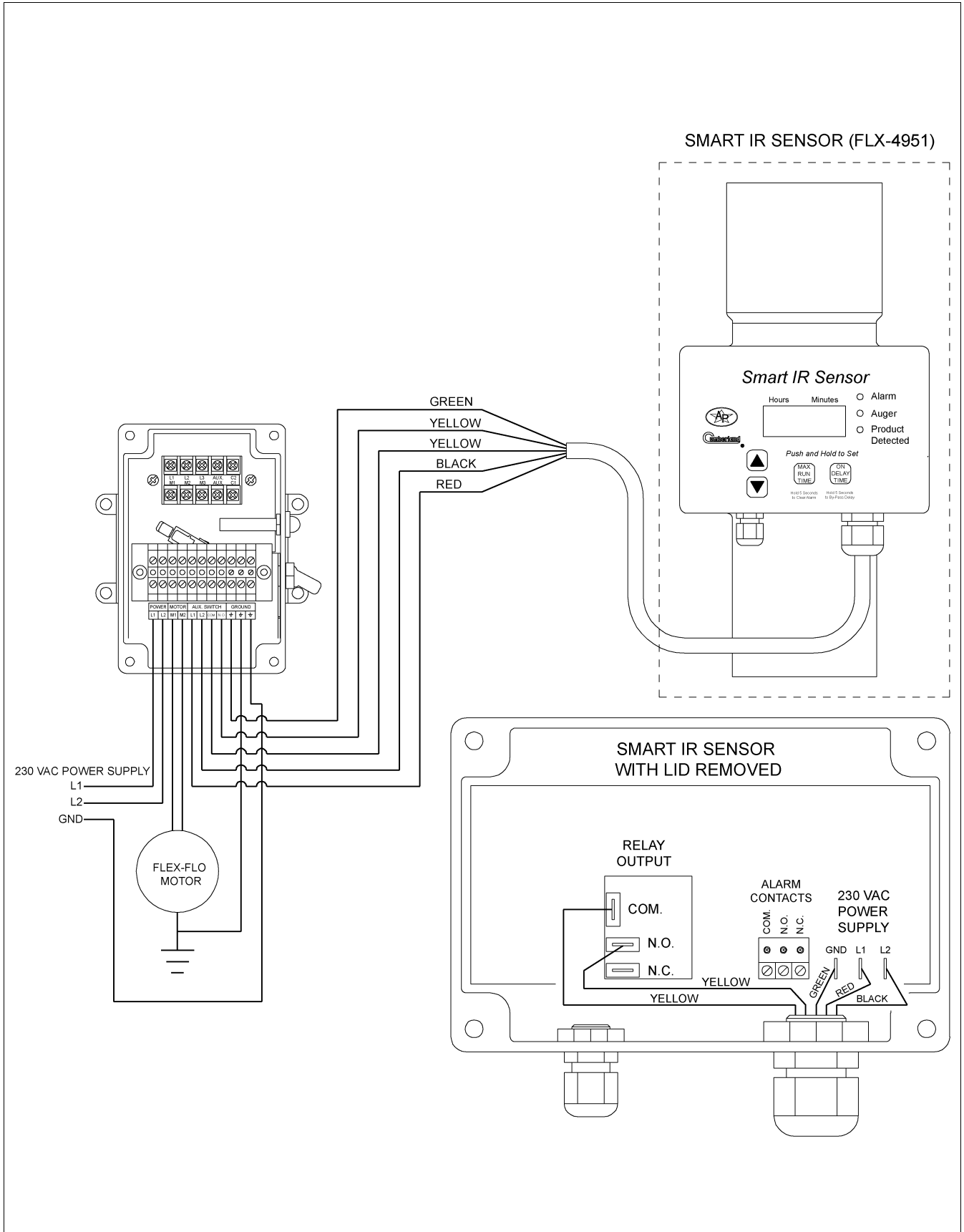

GSI Group, LLC Limited Warranty

The GSI Group, LLC ("GSI") warrants products which it manufactures to be free of defects in materials and workmanship under normal usage and conditions for a period of 12 months after sale to the original end-user or if a foreign sale, 14 months from arrival at port of discharge, whichever is earlier. The end-user's sole remedy (and GSI's only obligation) is to repair or replace, at GSI's option and expense, products that in GSI's judgment, contain a material defect in materials or workmanship. Expenses incurred by or on behalf of the end-user without prior written authorization from the GSI Warranty Group shall be the sole responsibility of the end-user.

Warranty Extensions:

The Limited Warranty period is extended for the following products:

	Product	Warranty Period
AP Fans and Flooring	Performer Series Direct Drive Fan Motor	3 Years
	All Fiberglass Housings	Lifetime
	All Fiberglass Propellers	Lifetime
Cumberland Feeding/Watering Systems	Feeder System Pan Assemblies	5 Years **
	Feed Tubes (1-3/4" and 2.00")	10 Years *
	Centerless Augers	10 Years *
	Watering Nipples	10 Years *
Grain Systems	Grain Bin Structural Design	5 Years
Grain Systems Farm Fans Zimmerman	Portable and Tower Dryers	2 Years
	Portable and Tower Dryer Frames and Internal Infrastructure †	5 Years

* Warranty prorated from list price:
0 to 3 years - no cost to end-user
3 to 5 years - end-user pays 25%
5 to 7 years - end-user pays 50%
7 to 10 years - end-user pays 75%

** Warranty prorated from list price:
0 to 3 years - no cost to end-user
3 to 5 years - end-user pays 50%

† Motors, burner components and moving parts not included. Portable dryer screens included. Tower dryer screens not included.

GSI further warrants that the portable and tower dryer frame and basket, excluding all auger and auger drive components, shall be free from defects in materials for a period of time beginning on the twelfth (12th) month from the date of purchase and continuing until the sixtieth (60th) month from the date of purchase (extended warranty period). During the extended warranty period, GSI will replace the frame or basket components that prove to be defective under normal conditions of use without charge, excluding the labor, transportation, and/or shipping costs incurred in the performance of this extended warranty.

Conditions and Limitations:

THERE ARE NO WARRANTIES THAT EXTEND BEYOND THE LIMITED WARRANTY DESCRIPTION SET FORTH ABOVE. SPECIFICALLY, GSI MAKES NO FURTHER WARRANTY OF ANY KIND, EXPRESS OR IMPLIED, INCLUDING, WITHOUT LIMITATION, WARRANTIES OF MERCHANTABILITY OR FITNESS FOR A PARTICULAR PURPOSE OR USE IN CONNECTION WITH: (I) PRODUCT MANUFACTURED OR SOLD BY GSI OR (II) ANY ADVICE, INSTRUCTION, RECOMMENDATION OR SUGGESTION PROVIDED BY AN AGENT, REPRESENTATIVE OR EMPLOYEE OF GSI REGARDING OR RELATED TO THE CONFIGURATION, INSTALLATION, LAYOUT, SUITABILITY FOR A PARTICULAR PURPOSE, OR DESIGN OF SUCH PRODUCTS.

GSI shall not be liable for any direct, indirect, incidental or consequential damages, including, without limitation, loss of anticipated profits or benefits. The sole and exclusive remedy is set forth in the Limited Warranty, which shall not exceed the amount paid for the product purchased. This warranty is not transferable and applies only to the original end-user. GSI shall have no obligation or responsibility for any representations or warranties made by or on behalf of any dealer, agent or distributor.

GSI assumes no responsibility for claims resulting from construction defects or unauthorized modifications to products which it manufactured. Modifications to products not specifically delineated in the manual accompanying the equipment at initial sale will void the Limited Warranty.

This Limited Warranty shall not extend to products or parts which have been damaged by negligent use, misuse, alteration, accident or which have been improperly/inadequately maintained. This Limited Warranty extends solely to products manufactured by GSI.

Prior to installation, the end-user has the responsibility to comply with federal, state and local codes which apply to the location and installation of products manufactured or sold by GSI.

This equipment shall be installed in accordance with the current installation codes and applicable regulations which should be carefully followed in all cases. Authorities having jurisdiction should be consulted before installations are made.



1004 E. Illinois St.
Assumption, IL 62510-0020
Phone: 1-217-226-4421
Fax: 1-217-226-4420
www.gsiag.com