

MGE_PulsarEvolution_1500_1100_800_500_iom_D403

www.mgeups.com

MGE UPS SYSTEMS

Pulsar Evolution

1500 /1500 Rack

1100 /1100 Rack

800 /800 Rack

500 Rack

**Installation and user
manual**



NOTHING WILL STOP YOU NOW

MGE
UPS SYSTEMS





MGE UPS Systems

1660 Scenic Avenue
Costa Mesa, CA 92626
(714) 557-1636

For service call

1-800-438-7373

www.mgeups.com

Important Safety Instructions

Read before installing product

Thank you for selecting an MGE UPS SYSTEMS product to protect your electrical equipment.

The Pulsar Evolution range has been designed with the utmost care. We recommend that you take the time to read this manual to take full advantage of the many features of your UPS.

MGE UPS SYSTEMS pays great attention to the environmental impact of its products. Measures that have made Pulsar Evolution a reference in environmental protection include:

- ▶ The eco-design approach used in product development,
- ▶ recycling of Pulsar Evolution at the end of its service life.

To discover the entire range of MGE UPS SYSTEMS products and the options available for the Pulsar Evolution range, we invite you to visit our web site at www.mgeups.com or contact your MGE UPS SYSTEMS representative.

This manual contains important instructions for Pulsar Evolution Models that must be followed during installation, operation and maintenance of the UPS and batteries.

The Pulsar Evolution UPS Models that are covered in this manual are listed below.

Pulsar Evolution 500, 800, 1100, 1500

The normal battery voltage for all models is as follows:

Pulsar Evolution 500-12V, 800-24V, 1100-24V, 1500-36V

The Pulsar Evolution UPS is intended for installation in a temperature within 0 to 35° C (Pulsar Evolution from 500 to 1100 VA) or within 0 - 40° C for Pulsar Evolution 1500, free of conductive contaminants.

Note



This equipment has been tested and found to comply with the limits for a Class A digital device, pursuant to Part 15 of the FCC Rules. These limits are designed to provide reasonable protection against harmful interference when the equipment is operated in a commercial environment. This equipment generates, uses, and can radiate radio frequency energy and, if not installed and used in accordance with the instruction manual, may cause harmful interference to radio communications. Operation of this equipment in a residential area is likely to cause harmful interference in which case the user will be required to correct the interference at his own expense.

Safety of persons

- ▶ The UPS has its own internal power source (the battery). Consequently, the power outlets may be energized even if the UPS is disconnected from the AC-power source.
- ▶ Dangerous voltage levels are present within the UPS. It should be opened exclusively by qualified service personnel.
- ▶ The UPS must be properly earthed. Measurements are required to ensure that the total leakage current of the UPS and the protected equipment does not exceed 3.5 mA by checking their characteristics (maximum leakage current of the UPS = 2 mA).
- ▶ The battery supplied with the UPS contains small amounts of toxic materials. To avoid accidents, the directives listed below must be observed:
 - Never burn the battery (risk of explosion).
 - Do not attempt to open the battery (the electrolyte is dangerous for the eyes and skin).
 - Comply with all applicable regulations for the disposal of the battery.
 - Batteries constitute a danger (electrical shock, burns). The short-circuit current may be very high. Precautions must be taken for all handling: remove watches, rings, bracelets and any other metal objects, use tools with insulated handles.

Product safety

- ▶ The UPS connection instructions and operation described in the manual must be followed in the indicated order.
- ▶ UPS must be connected to a nearby wall outlet that is easily accessible. The UPS can be disconnected from the AC-power source by removing the power cord.
- ▶ Check that the indications on the rating plate correspond to your AC-power system and to the actual electrical consumption of all the equipment to be connected to the UPS.
- ▶ Never install the UPS near liquids or in an excessively damp environment.
- ▶ Never let a foreign body penetrate inside the UPS.
- ▶ Never block the ventilation grates of the UPS.
- ▶ Never expose the UPS to direct sunlight or source of heat.
- ▶ If the UPS must be stored prior to installation, storage must be in a dry place.
- ▶ The admissible storage temperature range is -25°C to +55°C.

Special precautions

- ▶ All handling operations will require at least two people (unpacking, installation in rack system).
- ▶ Once installed and connected to the AC power source for the first time, the battery will start to charge. Full charging to obtain the rated battery backup time requires at least 8 hours.
- ▶ Before and after the installation, if the UPS remains de-energized for a long period, the UPS must be energized for a period of 24 hours, at least once every 6 months (for a normal storage temperature less than 25°C). This charges the battery, thus avoiding possible irreversible damage. During the replacement of the battery module, it is imperative to use the same type and number of element previously mounted in the UPS, in order to maintain an identical level of performance and safety. In case of doubt, don't hesitate to contact our after sales department (for more information, refer to the web site www.mgeups.com).

Foreword

Using this document

Information may be found in two ways, using:

- ▶ the contents;
- ▶ the index.

Pictograms



Important instructions that must always be followed.



Information, advice, help.



Visual indication.



Action.



Audio indication.

In the illustrations on the following pages, the symbols below are used:



LED off.



LED on.



LED flashing.

1. Presentation	
1.1 Overall view	7
Tower models	7
Rack models	7
1.2 Back	8
1.3 Control panel	9
2. Installation	
2.1 Unpacking and parts check	10
Tower models	10
Rack models	11
2.2 Installation	12
Tower models	12
800/1100/1500 Rack models.....	13
500 Rack model	14
2.3 Connecting the protected equipment	15
2.4 Connection to the RS232 or USB communications port (optional)	16
2.5 Connection to the data-line protection port (optional).....	16
2.6 Installation of the communications-card option	17
3. Operation	
3.1 Start-up	18
3.2 Shift to booster or fader mode (during voltage variations in the AC-input power)	18
3.3 Operation on battery power (following failure of AC-input power)	19
Transfer to battery power	19
Threshold for the low-battery warning.....	19
3.4 Personalisation (optional)	20
Function.....	20
ON / OFF conditions tab	20
Battery tab.....	20
Voltage-thresholds tab	21
Sensitivity tab	21



Contents

4. Maintenance	
4.1 Trouble-shooting	22
4.2 Replacement of the battery module	23
Tower models	23
Rack models	25
5. Environment	27
6. Appendices	
6.1 Technical data	
Simplified diagram.....	28
Technical characteristics	29
Examples of battery backup times	30
6.2 Glossary	31
6.3 Index	32

1. Presentation

1.1 Overall view

Tower models

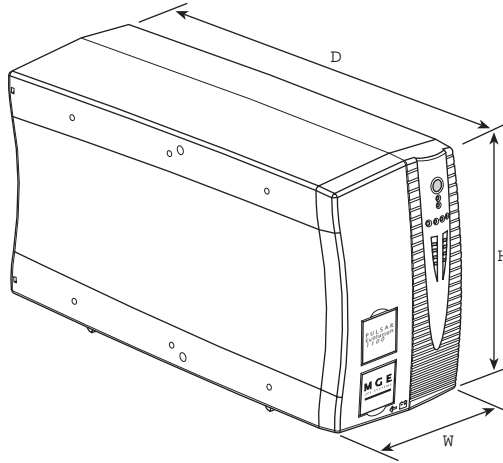

	Dimensions in inches (W x H x D)
Evolution 800	5.9 x 9.3 x 16.3
Evolution 1100	5.9 x 9.3 x 16.3
Evolution 1500	5.9 x 9.3 x 19

	Weight in lbs
Evolution 800	23
Evolution 1100	25.4
Evolution 1500 XL	33

Rack models

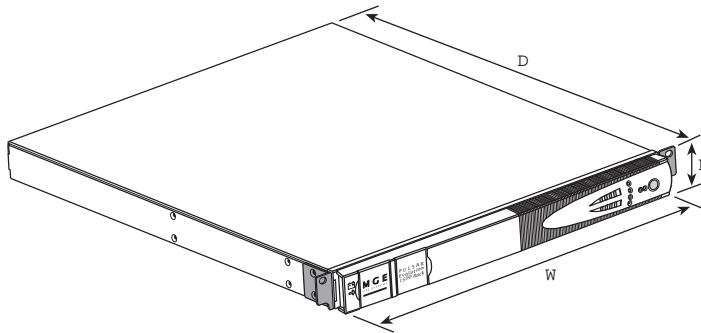

	Dimensions in inches (W x H x D)
Evolution 500 Rack	17.2 (19") x 1.7 (1U) x 13.9
Evolution 1100 Rack	17.2 (19") x 1.7 (1U) x 19.6
Evolution 1500 Rack	17.2 (19") x 1.7 (1U) x 20.5

	Weight in lbs
Evolution 500 Rack	20
Evolution 800 Rack	34
Evolution 1100 Rack	35
Evolution 1500 Rack	42

1. Presentation

1.2 Back

Pulsar Evolution 800 / 1100 / 1500

Pulsar Evolution:

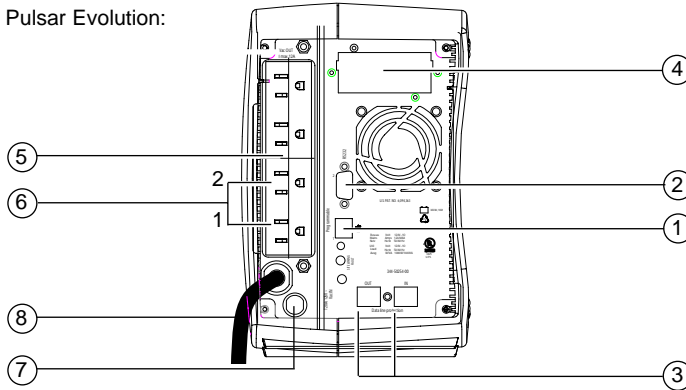

- ① USB communications port.
- ② RS232 communications port.
- ③ Data-line protection.
- ④ Slot for communications-card option.
- ⑤ Receptacle for direct connection of protected equipment.
- ⑥ Programmable receptacles (1 and 2).
- ⑦ Input circuit-breaker.
- ⑧ Connection to the utility.

Pulsar Evolution 500 / 800 / 1100 Rack

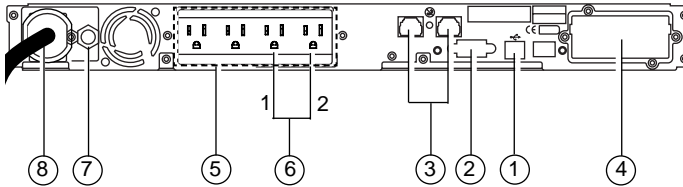

Pulsar Evolution 1500 Rack

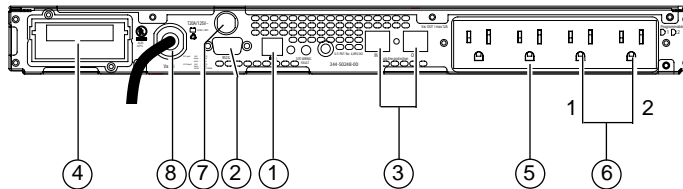

1.3 Control panel

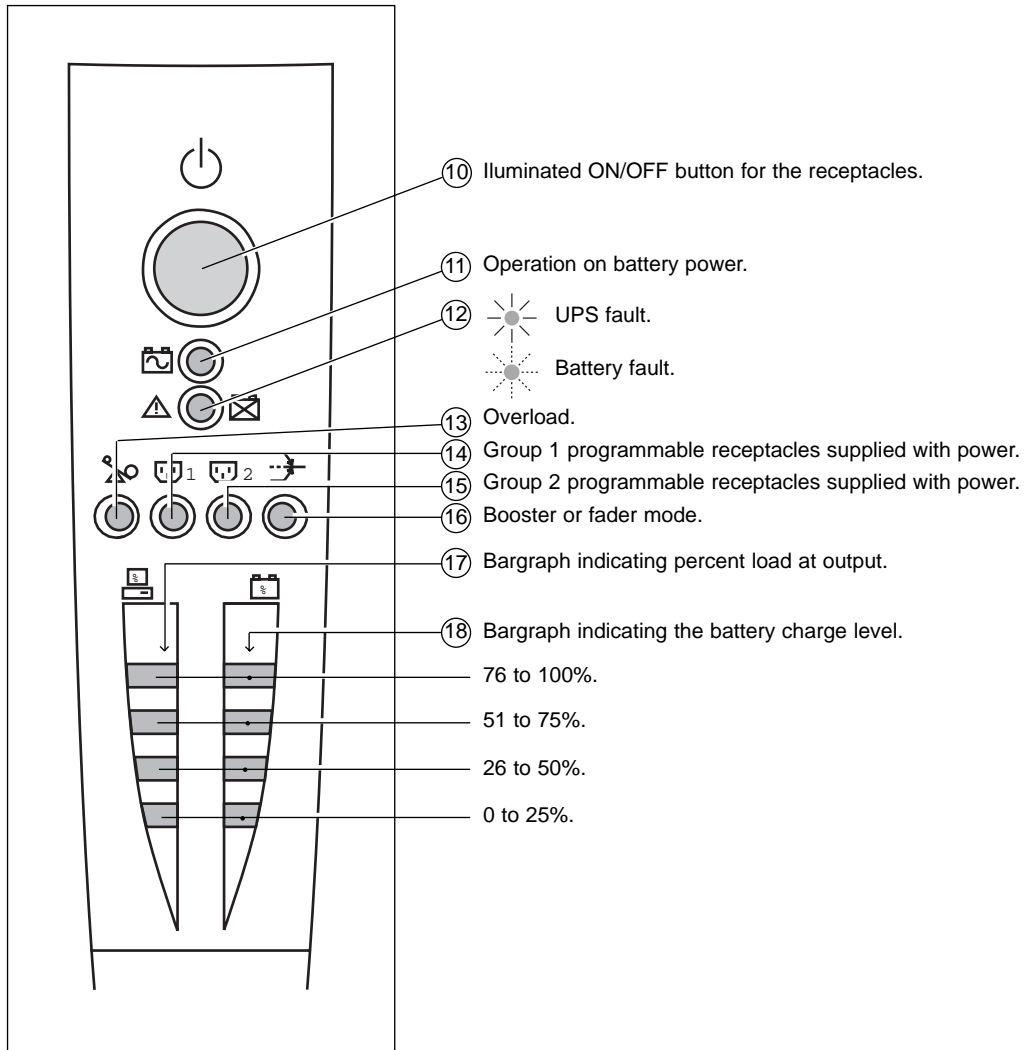

2. Installation

2.1 Unpacking and parts check

Tower models

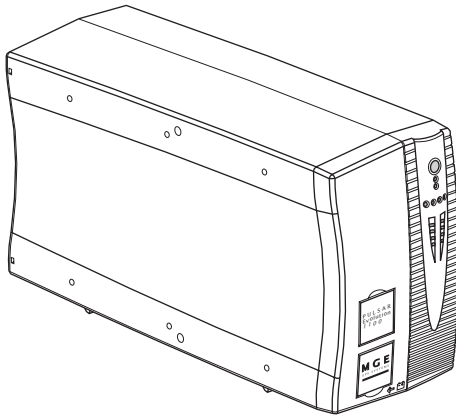
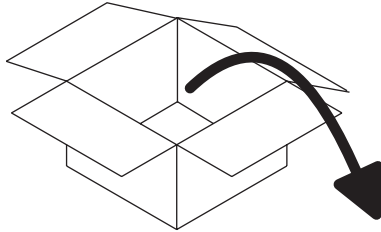

⑳

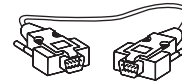

㉑

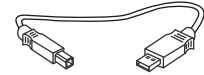

㉒



㉓

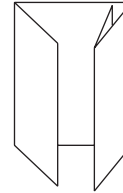

㉔

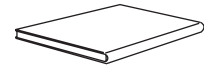

- ㉑ RS232 communications cable for Windows Operating Systems. For Unix/Linux Operating Systems, please order for free the following part number: 66090
- ㉒ USB communications cable.
- ㉓ CD-ROM with the Solution-Pac and UPS Driver software.
- ㉔ Product documentation.

2. Installation

Rack models

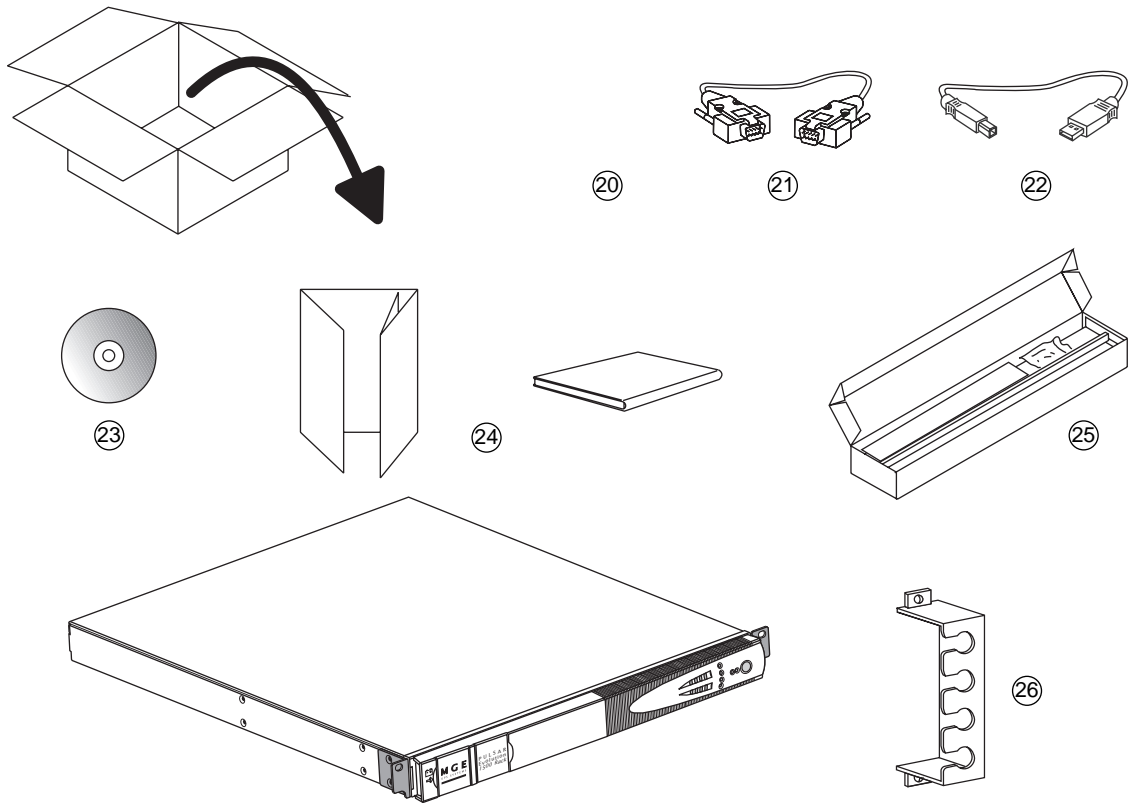

- ②1 RS232 communications cable for Windows Operating Systems. For Unix/Linux Operating Systems, please order for free the following part number: 66090
- ②2 USB communications cable.
- ②3 CD-ROM with the Solution-Pac and UPS Driver software.
- ②4 Product documentation.
- ②5 Telescopic rails for mounting in 19" bay with mounting hardware.
- ②6 Securing system for equipment power cords.

2. Installation

2.2 Installation

Tower models

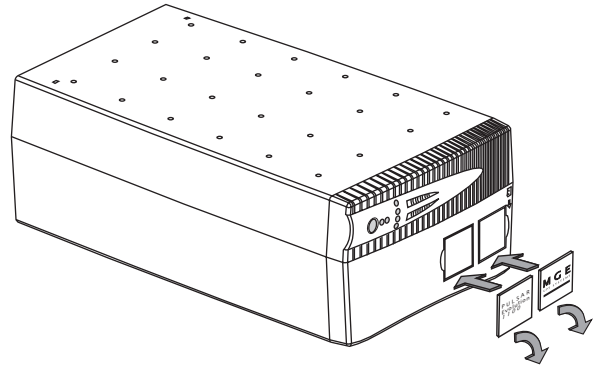
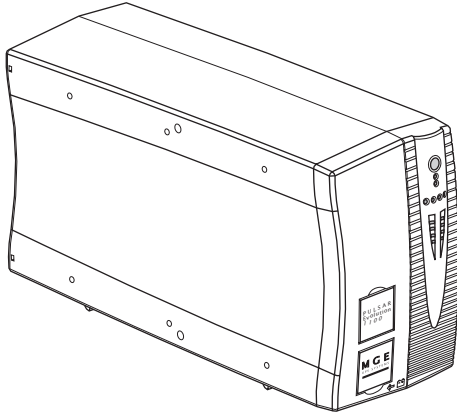

2. Installation

800/1100/1500 Rack models

Follow steps 1 to 6 for rack mounting of the UPS on the rails.

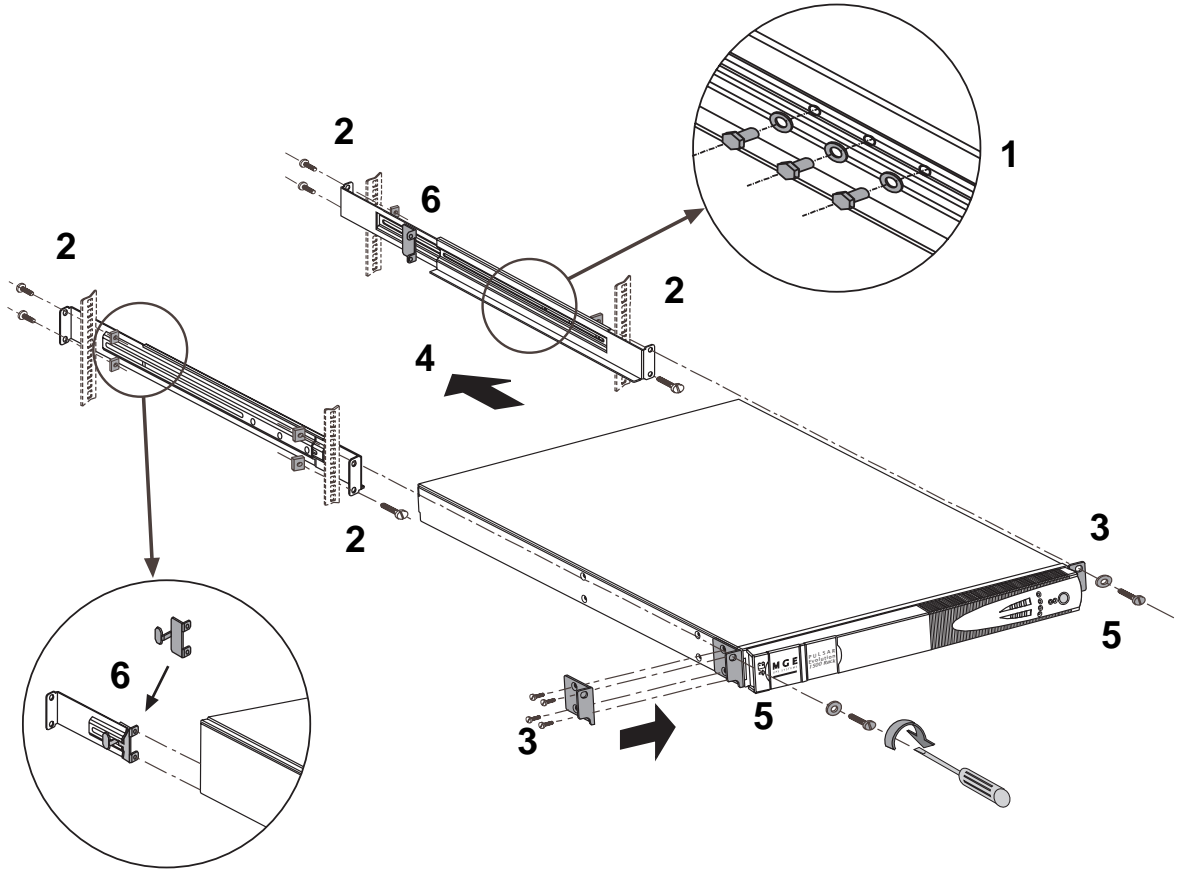

The rails and the necessary mounting hardware are supplied by MGE UPS SYSTEMS.

2. Installation

500 Rack model

Follow steps 1 to 3 for rack mounting of the UPS on the rails.

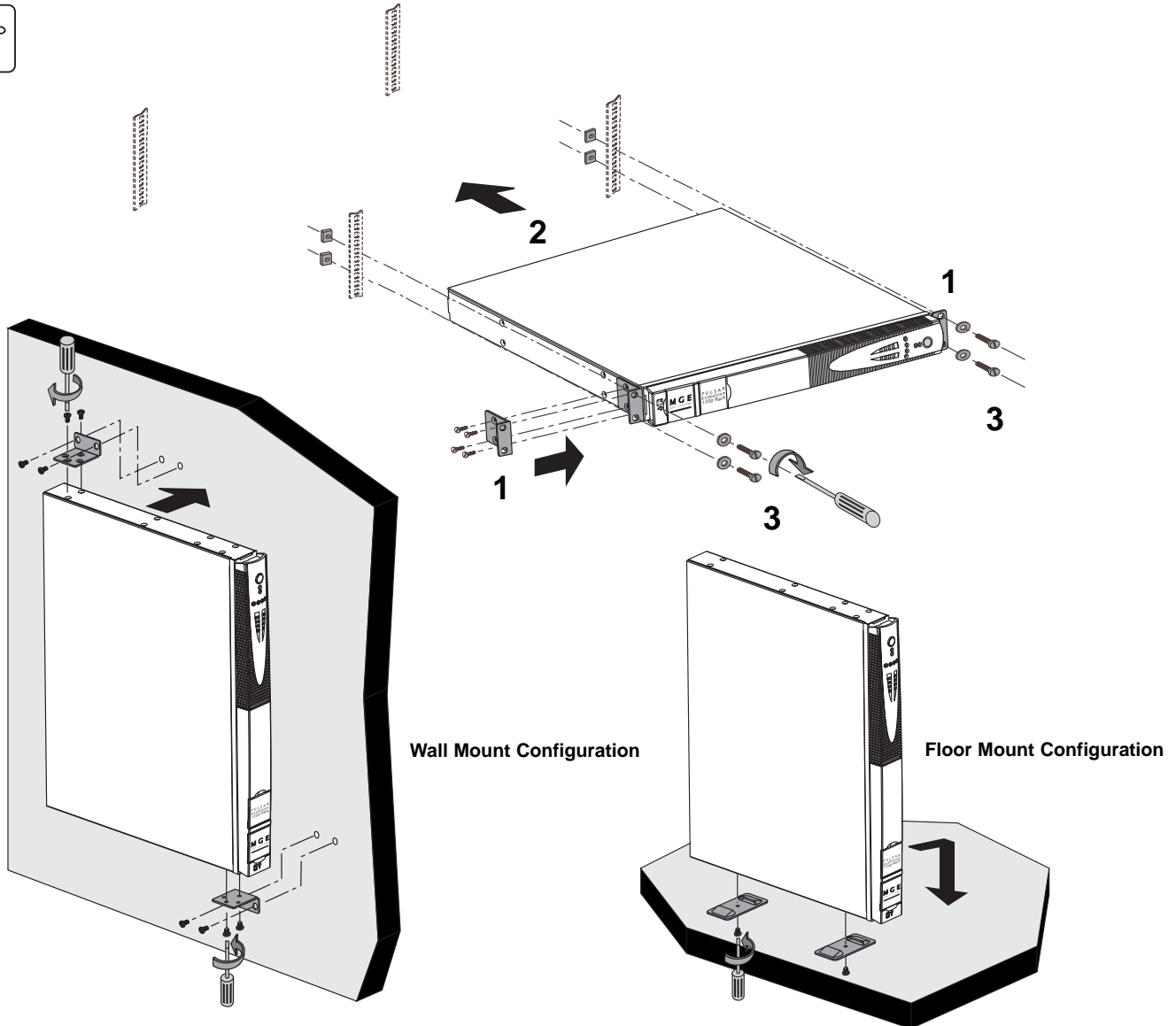

2. Installation

2.3 Connecting the protected equipment

A Pulsar Evolution 1500 tower UPS has been used below to illustrate the instructions. The principle is the same for all the other tower and rack models.

Check that the indications on the rating plate on the back of the UPS correspond to your AC-power system and to the actual electrical consumption of all the equipment to be connected to the UPS.

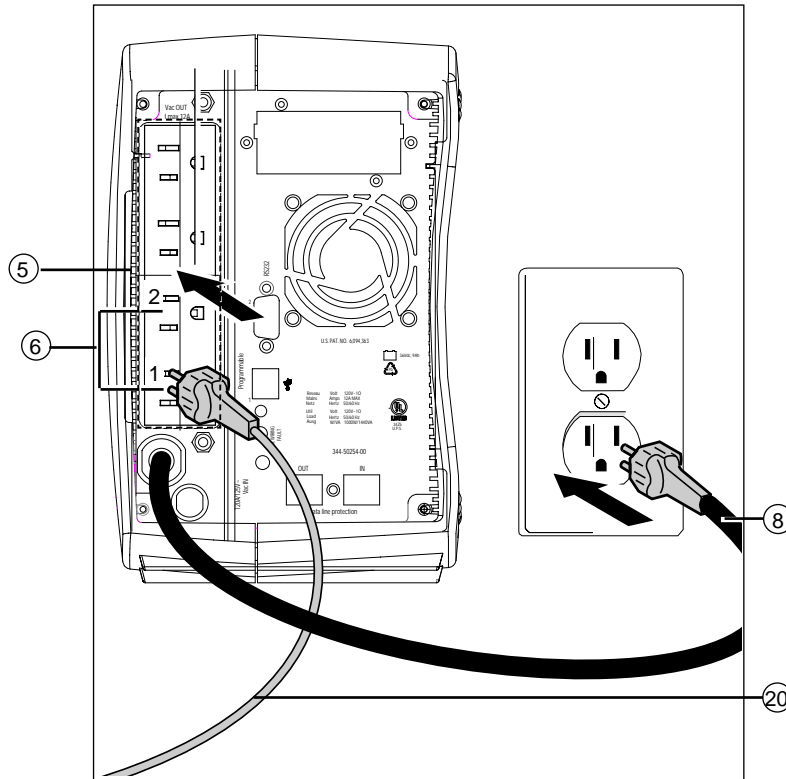

1 - Remove the power cord supplying the equipment to be protected.

2 - Connect the power cord to the AC-power wall receptacle (8).

3 - Connect the protected equipment to the UPS using the cord (20). Connect critical loads to the two standard receptacles (5) and any non-critical loads to the two programmable receptacles (6) (1 and 2).

If the UPS is connected to a computer running MGE communications software, it is possible to program the interruption of power to the programmable receptacles (6) during operation on battery power, thus reserving backup power for the critical loads.



4 - Lock the connections using the securing system 26 (for rack models only).



As soon as the UPS is energised, the battery begins charging. Eight hours are required to charge to the full rated backup time.

2. Installation

A Pulsar Evolution 1500 tower UPS has been used below to illustrate the instructions. The principle is the same for all the other tower and rack models.

2.4 Connection to the RS232 or USB communications port (optional)

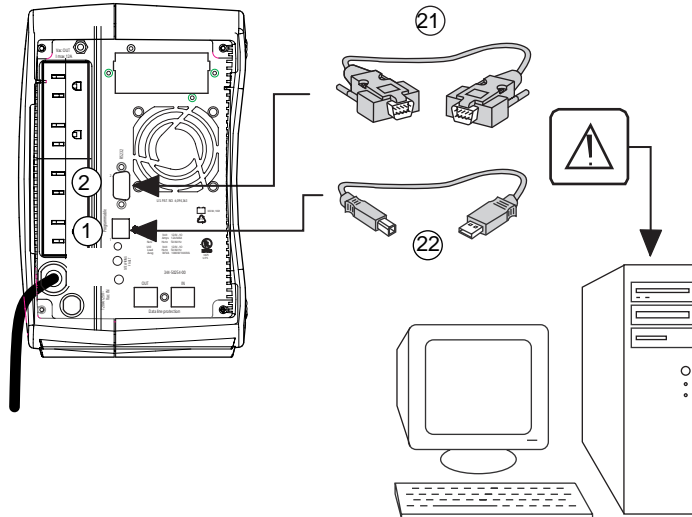

The RS232 and USB communications ports cannot operate simultaneously.

1 - Connect the RS232 ②1 or USB ②2 communications cable to the serial port or the USB port on the computer.

2 - Connect the other end of the communications cable ②1 or ②2 to the RS232 ② or USB ① communications port on the UPS.

The UPS can now communicate with all MGE UPS SYSTEMS supervision, set-up or safety software.

2.5 Connection to the data-line protection port (optional)

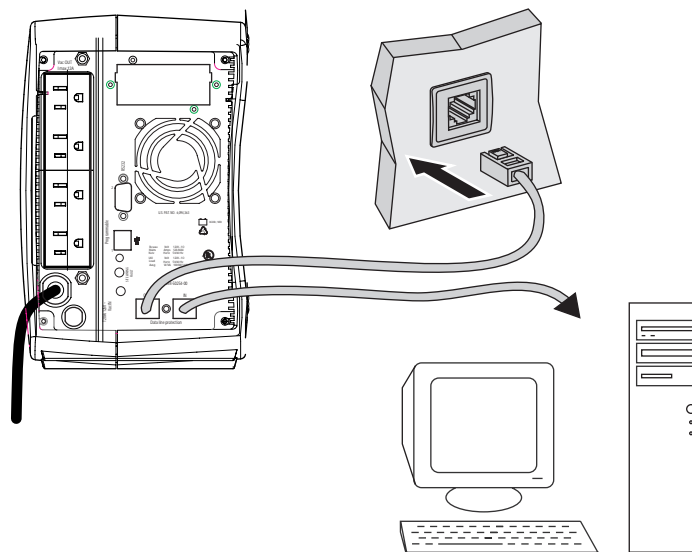

The data-line protection function on the UPS eliminates overvoltages flowing on the computer-network lines.

Simply connect the line to be protected to the UPS using the data-line protection connectors (IN and OUT) as indicated opposite (RJ45 cables not supplied).

2. Installation

2.6 Installation of the communications-card option

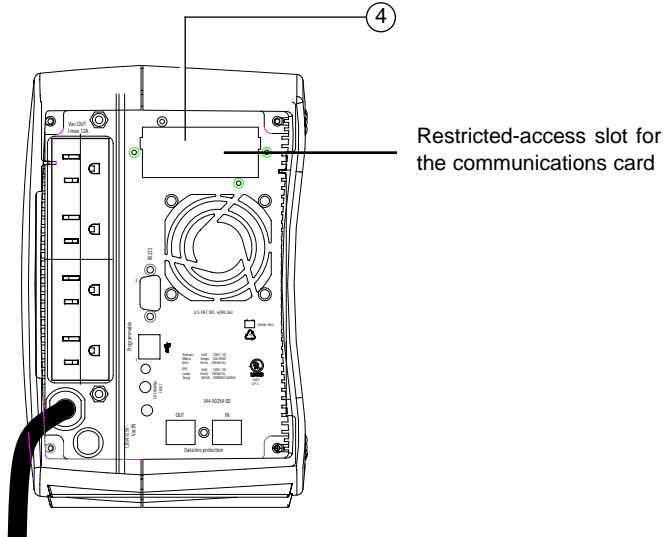

- 1 - Remove the slot cover (4) secured by two screws.
- 2 - Insert the card in the slot.
- 3 - Secure the card with the two screws.



It is not necessary to shut down the UPS to install the communications card.
This operation must be carried out by qualified personnel.

3. Operation

3.1 Start-up

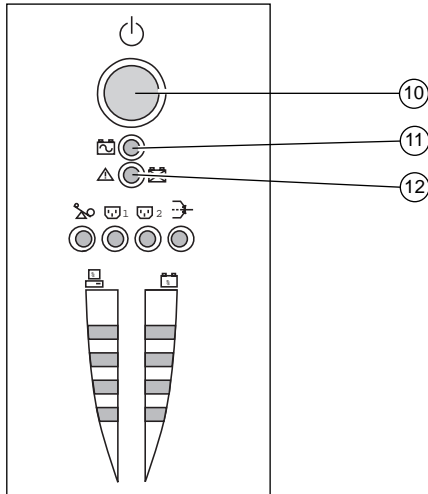
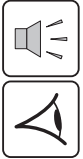

Press the ON / OFF button (10).

The buzzer beeps and all the LEDs come ON.

The buzzer beeps twice during the self-test, then button (10) remains ON, indicating that the receptacles are supplied with power.

- **AC power is present:** Only button (10) is ON. The protected equipment is supplied by the AC-power source.

- **AC power is absent:** Button (10) and LED (11) are ON. The protected equipment is supplied by the UPS, operating on battery power.

All the connected equipment is supplied with power.

If button (10) or LED (11) are not ON or if LED (12) is ON, there is a fault (see section 4.1).



Note: The battery is charged as soon as the UPS is connected to the AC-power source, even if button (10) is in the OFF position.

3.2 Shift to booster or fader mode (during voltage variations in the AC-input power)

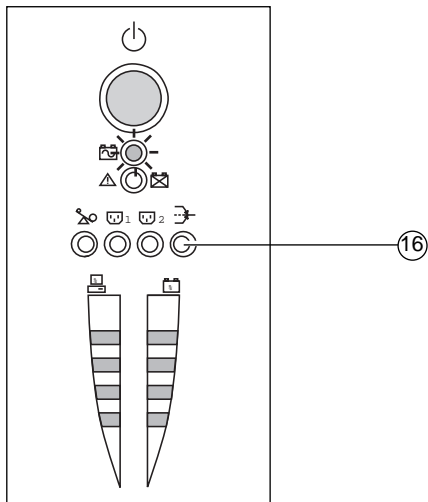

The booster and fader functions maintain the output voltage supplied by the UPS within close tolerances around the rated value even if significant voltage variations occur in the AC-input power. This avoids calling on battery power.

The values defining the voltage range may be set using the UPS Driver software.

During operation in booster or fader mode, LED (16) is ON, signalling a significant voltage variation in the AC-input power.

3. Operation

3.3 Operation on battery power (following failure of AC-input power)

Transfer to battery power

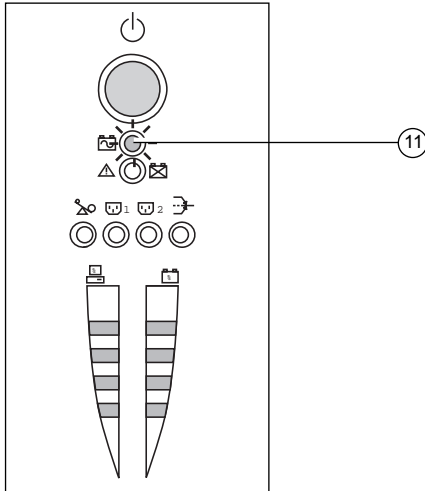

The AC-input power is out of tolerances, LED (11) goes ON.
During operation on battery power, the buzzer beeps every ten seconds.

The equipment connected to the UPS is supplied by the battery.

Threshold for the low-battery warning

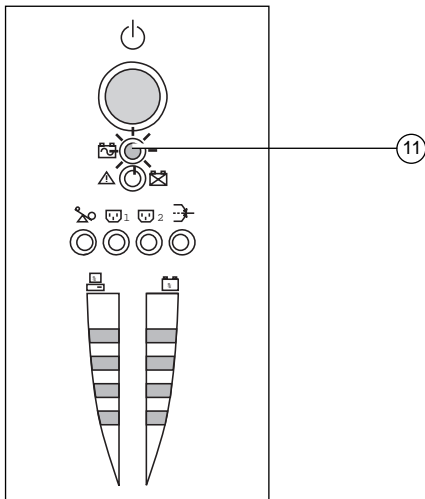

When the threshold is reached, the buzzer beeps every three seconds.
The low-battery warning threshold can be set by the user, with the “UPS Driver” software.

There is very little remaining battery backup time. Close all applications because UPS automatic shutdown is imminent.

When the battery reaches the end of its backup time, the UPS shuts down and all the LEDs go OFF.

The equipment is no longer supplied with power.



The UPS automatically restarts when power returns.

If the UPS does not restart, check that the “automatic restart when power returns” function has not been disabled (see section 3.4 Personalisation).

3. Operation

3.4 Personalisation (optional)

Function

Personalisation parameters can be set and modified using the UPS Driver software installed on a computer that is connected to the UPS (see section 2.4 Connection to the RS232 communications port).

Check that the RS232 (21) communications cable is connected.

UPS Driver installation:



- 1 - Insert the Solution-Pac CD-ROM containing the UPS Driver software in the drive of a PC running Windows.
- 2 - Open the Windows File manager or Explorer and select the CD-ROM drive.
- 3 - Double-click "\\Emb\Evolutio\Config\upsdriv.exe".

Once UPS Driver has been installed, UPS parameters can be modified in a window containing a number of tabs, each presenting a set of parameters :

ON / OFF conditions tab

Configurable function	Default setting	Options
Automatic restart	Enabled	Disabled
Cold start	Enabled	Disabled
Forced reboot	Enabled	Disabled
Energy saving	Disabled	Enabled
UPS ON / OFF via software	Enabled	Disabled

Battery tab

Configurable function	Default setting	Options
Interval between automatic battery tests	Once a week	Every day Once a month No test
Low-battery warning threshold	20% of the remaining battery backup time	10 to 40% of the remaining battery backup time
Protection against deep discharges	Enabled	Disabled

3. Operation

Voltage-thresholds tab

Configurable function	Default setting	Options
Output voltage on battery power	120 V	100 - 127 V
Upper threshold for transfer to battery power	153 V	141 to 153 V
Fader-mode cut-in threshold	138 V	127 to 138 V
Booster-mode cut-in threshold	92 V	92 to 108 V
Lower threshold for transfer to battery power	80 V	80 to 94 V
Maximum input-voltage range	Disabled	Enabled (1)

(1) Lower threshold for transfer to battery mode = 70 V

Sensitivity tab

Configurable function	Default setting	Options
UPS sensitivity level	Normal	High or low



For more informations about these settings, refer to the Help function of the "UPS Driver" software.

4. Maintenance

4.1 Trouble-shooting

Troubleshooting not requiring MGE UPS SYSTEMS after-sales support (all versions)

Indication	Signification	Correction
LED ⑬ flashes and the buzzer beeps once.	UPS overload. The power drawn by the connected equipment exceeds UPS capacity.	Check the power drawn by the equipment and disconnect any non-priority devices.
LED ⑫ flashes.	A battery fault was detected during the automatic battery test.	Replace the battery module (see section 4.2).

Troubleshooting requiring MGE UPS SYSTEMS after-sales support

Indication	Signification	Correction
LED ⑫ goes ON and the buzzer sounds continuously.	<p>UPS electronics have detected a UPS fault.</p> <ul style="list-style-type: none">▶ The connected equipment is no longer supplied. <p> The equipment connected to the UPS is no longer protected.</p>	Call the after-sales support department.

4.2 Replacement of the battery module

Tower models

Safety rules

Batteries constitute a danger (electrical shock, burns). The short-circuit current may be very high. Precautions must be taken for all handling:

- ▶ remove all watches, rings, bracelets and any other metal objects;
- ▶ use tools with insulated handles.



Removal of the battery module

This operation may be carried out with the UPS supplying power to the load.

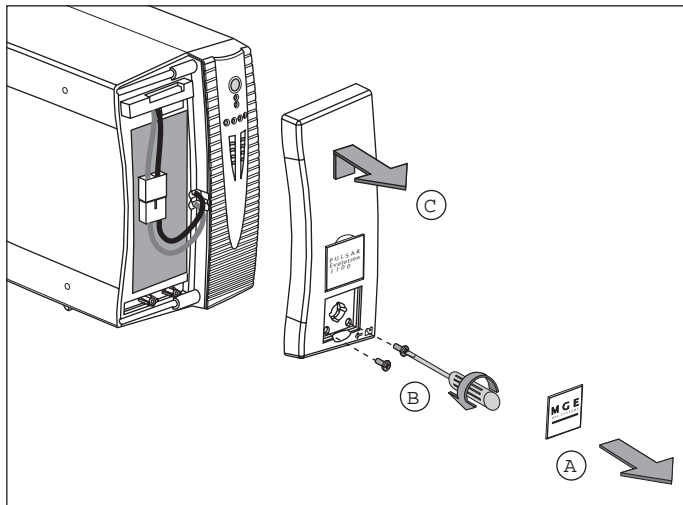

- (A) - Unclip the small plate with the MGE logo on the front panel of the UPS.
- (B) - Remove the two screws.
- (C) - Remove the left-hand side of the front panel by pulling it slightly up and then forward.

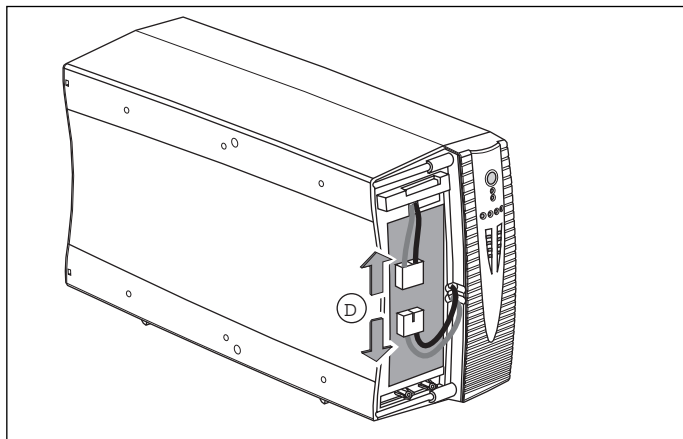

- (D) - Disconnect the battery module by pulling apart the connectors (never pull on the cables).

4. Maintenance

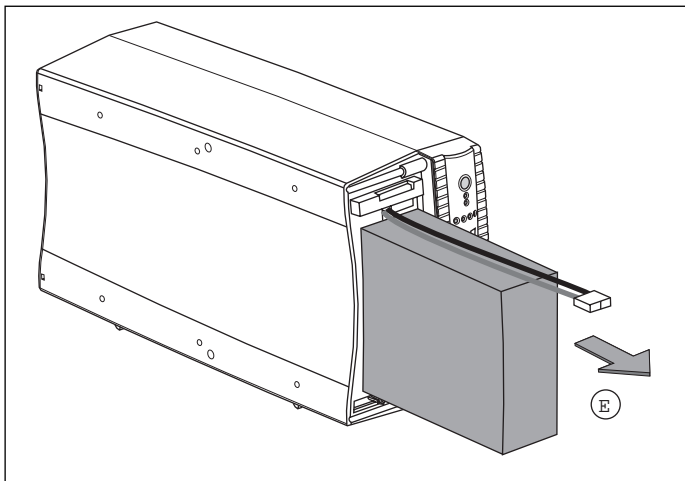

Ⓔ - Remove the battery module by pulling on the plastic tab and proceed with replacement.

Installation of the new battery module

Carry out the above operation in reverse order.



- ▶ **Caution:** risk of electric arc when connecting the battery.
- ▶ To maintain an identical level of performance and safety, use a battery module identical to that previously mounted in the UPS.
- ▶ Press the two parts of the battery connector tightly together to ensure proper connection.

4. Maintenance

Rack models

Removal of the battery module

This operation may be carried out with the UPS supplying power to the load.

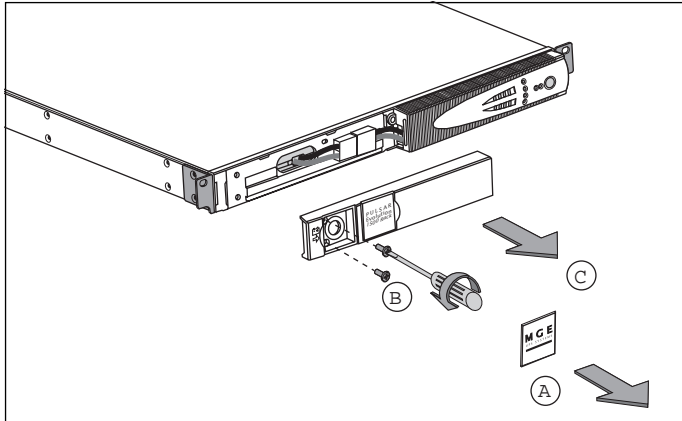

- (A) - Unclip the small plate with the MGE logo on the front panel of the UPS.
- (B) - Remove the two screws.
- (C) - Remove the left-hand side of the front panel by pulling it forward.

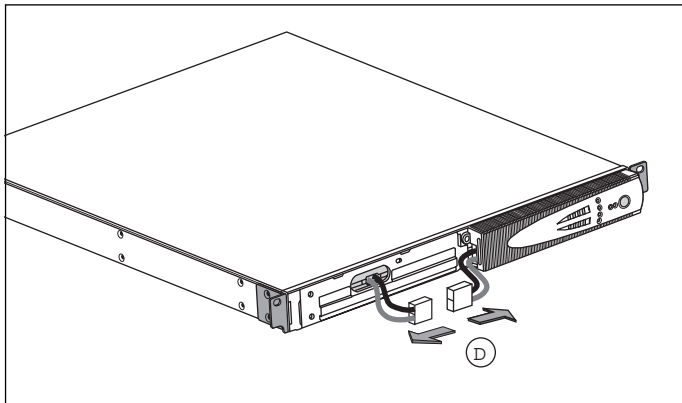

- (D) - Disconnect the battery module by pulling apart the connectors (never pull on the cables).

4. Maintenance

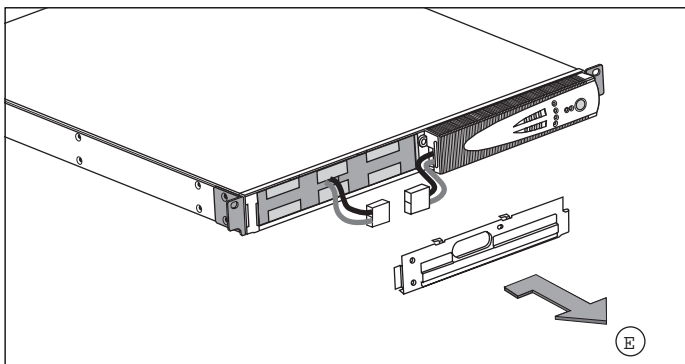

Ⓔ - Remove the cover.

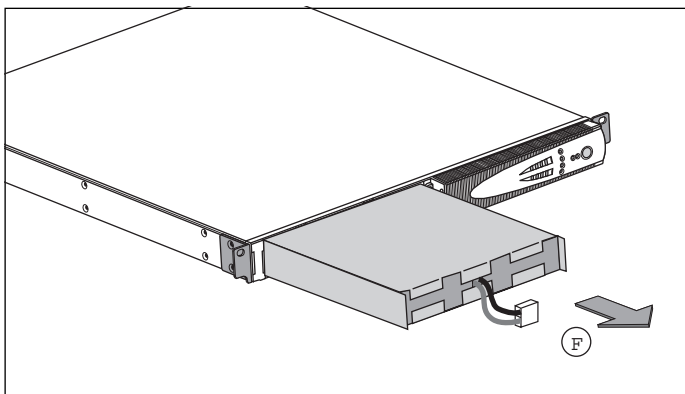

Ⓕ - Remove the battery module by pulling on the plastic tab and proceed with replacement.

Installation of the new battery module

Carry out the above operation in reverse order.



- ▶ **Caution:** risk of electric arc when connecting the battery.
- ▶ To maintain an identical level of performance and safety, use a battery module identical to that previously mounted in the UPS.
- ▶ Press the two parts of the battery connector tightly together to ensure proper connection.



5. Environment

This product has been designed to respect the environment:

It does not contain CFCs or HCFCs.

UPS recycling at the end of service life:

MGE UPS SYSTEMS undertakes to recycle, by certified companies and in compliance with all applicable regulations, all UPS products recovered at the end of their service life (contact your MGE branch office).

Packing:

UPS packing materials must be recycled in compliance with all applicable regulations.

Warning:

This product contains lead-acid batteries. Lead is a dangerous substance for the environment if it is not properly recycled by specialised companies.

Web site: www.mgeups.com

6. Appendices

6.1 Technical data

Simplified diagram

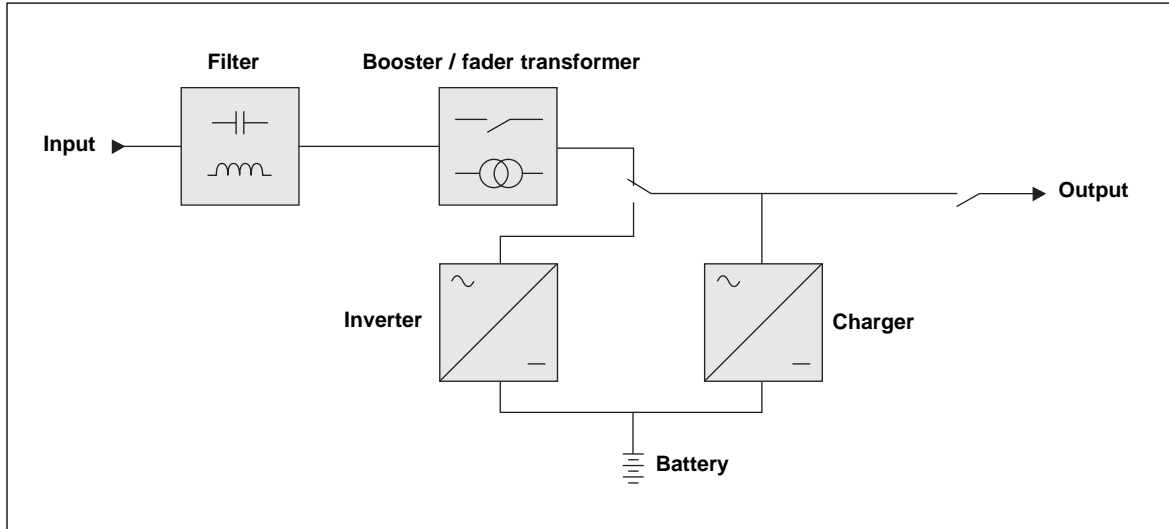

6. Appendices

Technical characteristics

Pulsar Evolution	500	800 / 800 rack	1100 / 1100 rack	1500 / 1500 rack
Output rating	500 VA / 350 W	800 VA / 560 W	1100 VA / 700 W	1500 VA / 1000 W
AC-input power ▶ Voltage ▶ Frequency	Single phase, 80 V to 153 V (1) 47 Hz to 70 Hz (50 Hz system) or 56.5 Hz to 70 Hz (2) (60 Hz system)			
Output power (operation on battery power) ▶ Voltage ▶ Frequency	Single-phase, 120 V (3) (+ 6% / - 10%) 50/60 Hz +/- 1 Hz			
Battery (sealed lead-acid, maintenance free) ▶ Tower models ▶ Rack models	2 x 6 V - 9 Ah,	2 x 12 V - 7.2 Ah, 4 x 6 V - 7.2 Ah	2 x 12 V - 9 Ah, 4 x 6 V - 9 Ah	3 x 12 V - 9 Ah, 6 x 6 V - 9 Ah
Environment ▶ Noise level (operation on AC-input power) ▶ Operating temperature ▶ Relative humidity (without condensation)	<40 dBA 0 to 35° C 20 to 90%			<40 dBA 0 to 40° C 20 to 90%

(1) The upper and lower thresholds may be set using the UPS Driver software.

(2) Or 40 Hz in low-sensitivity mode (may be set using the UPS Driver software).

(3) Adjustable from 100 to 127 V using the UPS Driver software.

6. Appendices

Examples of battery backup times

Pulsar Evolution 500

2 rack-optimized dense servers

1 router

1 hub

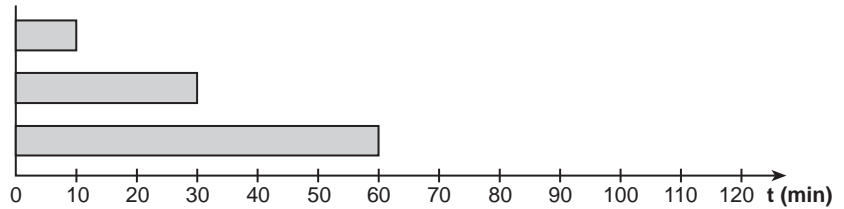

Pulsar Evolution 800

3 rack-optimized dense servers

2 file/print servers

1 data server + 1 hub + 1 router

1 router

1 hub

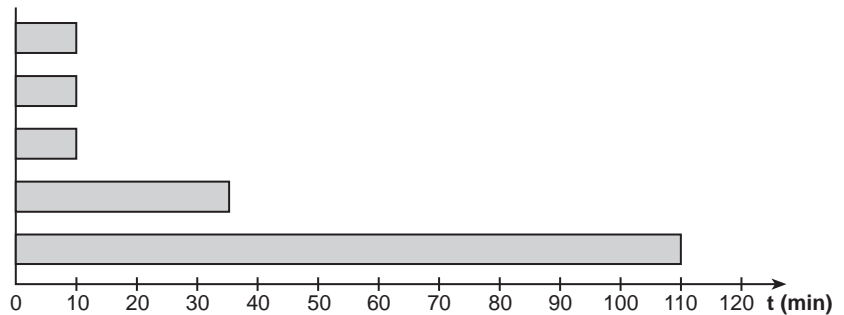

Pulsar Evolution 1100

3 rack-optimized dense servers

2 file/print servers

1 data server + 1 hub + 1 router

1 router

1 hub

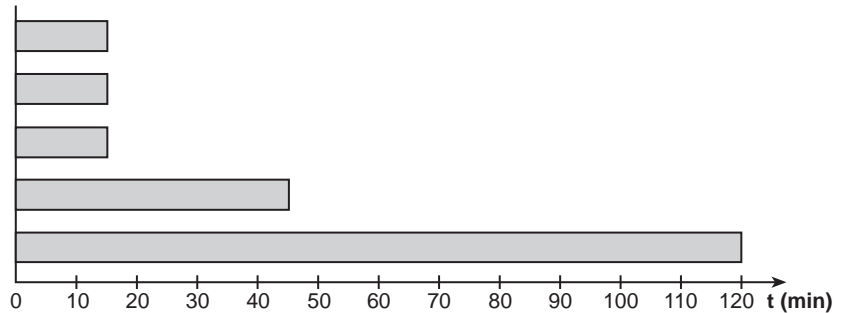

Pulsar Evolution 1500

5 rack-optimized dense servers

3 file/print servers

2 data servers + 1 hub + 1 router

1 router

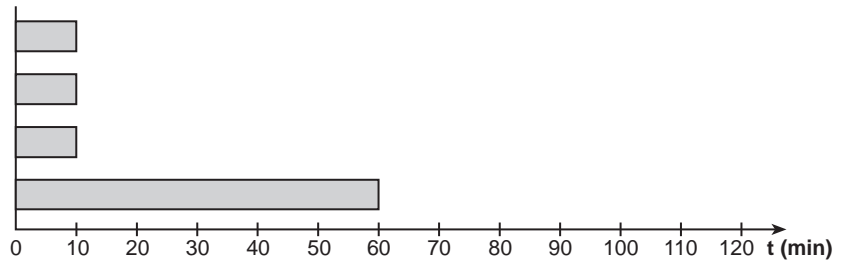

6.2 Glossary

Backup time	Time that the connected equipment can operate on battery power if AC-input power fails.
Bargraph	Device on the front panel indicating the percent remaining backup time or the percent load.
Booster mode	Automatic UPS operating mode whereby the input-power voltage is increased if it drops below a value set in the personalisation parameters, thus avoiding a battery discharge.
De-energised	The UPS must be physically disconnected from the AC-input power.
Equipment	Devices and systems connected to the UPS output.
Fader mode	Automatic UPS operating mode whereby the input-power voltage is decreased if it rises above a value set in the personalisation parameters, thus avoiding a battery discharge.
Input circuit breaker	Circuit breaker protecting the upstream distribution system against UPS faults.
Personalisation	The parameters for a number of UPS functions may be modified using the UPS Driver software to adapt UPS operation to user needs.
Programmable receptacles	Pulsar Evolution has two programmable receptacles. They may be used for sequential start-up of protected equipment, shedding of non-critical loads during operation on battery power or management of operating priorities to provide the most critical devices with more backup time before battery power runs out. These receptacles may be programmed using the Solution-Pac software on the CD-ROM supplied with the UPS.
Receptacles	Receptacle that allows you to connect the equipment you want to protect.
RS232 communications port	For UPS connection to a computer via the serial port.
Solution-Pac	MGE UPS SYSTEMS safety, set-up and supervision software suite on the CD-ROM supplied with the UPS.
UPS	Uninterruptible Power Supply.
UPS Driver	Communications software on the CD-ROM supplied with the UPS. It may be used to personalise the default settings.
USB communications port	For UPS connection to a computer via the USB port.

6. Appendices

6.3 Index

A

Automatic start20

B

Bargraph.....9

Battery

Backup time30

End of backup time.....19

Fault9

Personalisation20

Recycling27

Replacement22, 23, 24

Threshold for low-battery warning19

Transfer to battery power9, 19

Buttons9

Buzzer19

C

Circuit breakers

Battery circuit breaker.....8

Input circuit breaker8

Communication

Cards8, 17

Ports8, 16

Connections

Data-line protection.....16

RS232 communications port16

USB communications port16

D

Dimensions.....7

E

Environment27

F

Fault (UPS).....9

L

LEDs.....9

M

Mode

Booster mode9, 18

Fader mode9, 18

Sleep mode (automatic start)20

O

Overloads9, 22

P

Personalisation20

Battery20

ON / OFF conditions20

Output.....21

Ports

RS2328, 16

USB8, 16

Programmable receptacles8, 9

S

Safety.....23

Start-up18

T

Technical characteristics29

Temperature (excessive ambient)29

U

UPS Driver.....18, 19, 20, 29

UPS ON / OFF via software20

W

Web site.....27

Weight7