

NordicTrack[®] CX 985

Model No. NTE11920

Serial No. _____

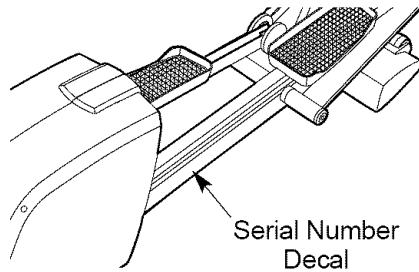

USER'S MANUAL

QUESTIONS?

If you have questions, or if there are missing parts, we will guarantee complete satisfaction through direct assistance from our factory.

TO AVOID DELAYS, PLEASE CALL DIRECT TO OUR TOLL-FREE CUSTOMER HOT LINE. The trained technicians on our customer hot line will provide immediate assistance, free of charge to you.

CUSTOMER HOT LINE:

1-888-825-2588

Mon.–Fri., 6 a.m.–6 p.m. MST

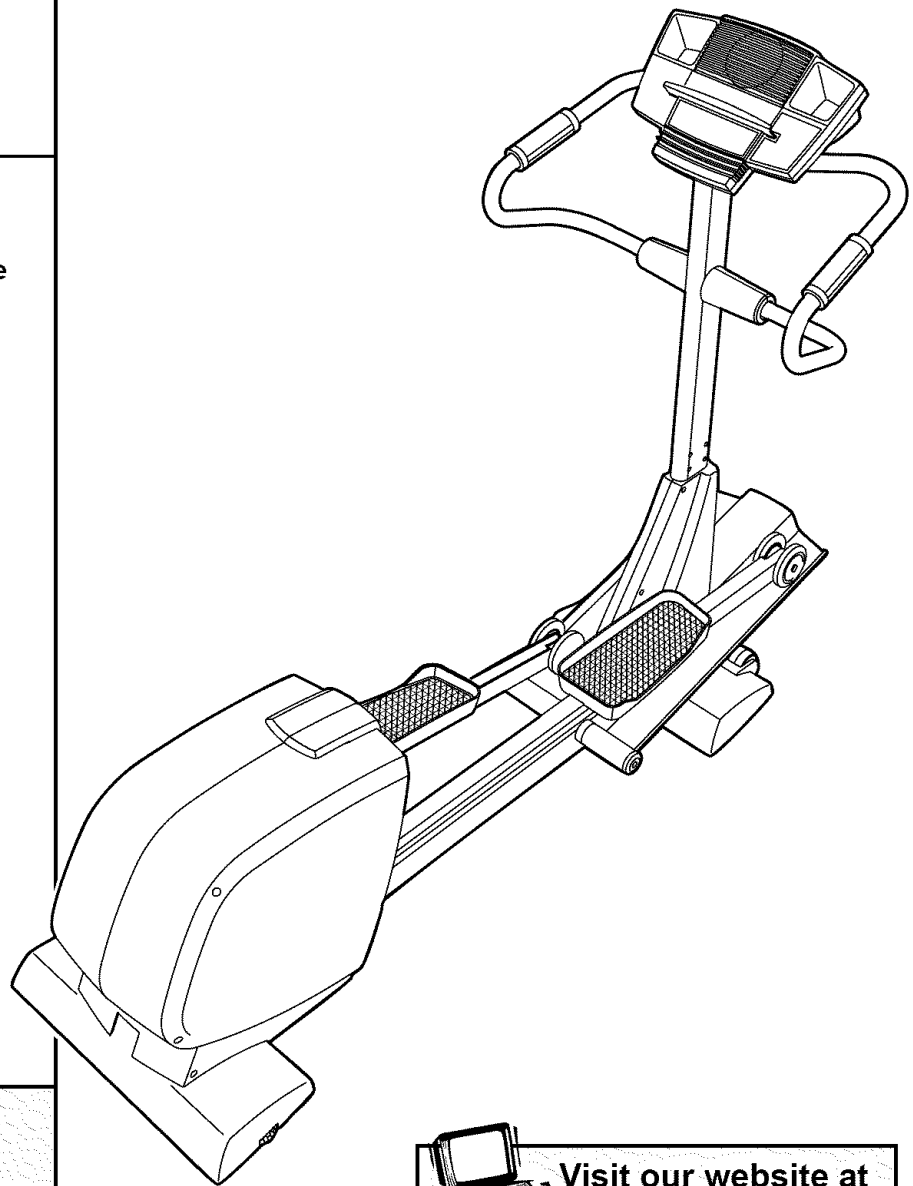

CAUTION

Read all precautions and instructions in this manual before using this equipment. Keep this manual for future reference.



Visit our website at

www.nordictrack.com

*new products, prizes,
fitness tips, and much more!*



NordicTrack®

CX 985

TABLE OF CONTENTS

IMPORTANT PRECAUTIONS	3
BEFORE YOU BEGIN	4
ASSEMBLY	5
HOW TO USE THE ELLIPTICAL EXERCISER	10
MAINTENANCE AND TROUBLESHOOTING	22
CONDITIONING GUIDELINES	23
PART LIST	24
EXPLODED DRAWING	26
HOW TO ORDER REPLACEMENT PARTS	Back Cover
LIMITED WARRANTY	Back Cover

IMPORTANT PRECAUTIONS

⚠ WARNING: To reduce the risk of serious injury, read the following important precautions before using the elliptical exerciser.

1. Read all instructions in this manual before using the elliptical exerciser.
2. It is the responsibility of the owner to ensure that all users of the elliptical exerciser are adequately informed of all precautions.
3. The elliptical exerciser is intended for in-home use only. Do not use the elliptical exerciser in a commercial, rental, or institutional setting.
4. Place the elliptical exerciser on a level surface, with a mat beneath it to protect the floor or carpet. Keep the elliptical exerciser indoors, away from moisture and dust.
5. Inspect and properly tighten all parts regularly. Replace any worn parts immediately.
6. Keep children under age 12 and pets away from the elliptical exerciser at all times.
7. The elliptical exerciser should not be used by persons weighing more than 250 pounds.
8. Wear appropriate exercise clothing when using the elliptical exerciser. Always wear athletic shoes for foot protection.
9. Always hold the handlebars when mounting, dismounting, or using the elliptical exerciser.
10. Keep your back straight when using the elliptical exerciser; do not arch your back.
11. If you feel pain or dizziness while exercising, stop immediately and cool down.
12. The pulse sensor is not a medical device. Various factors, including the user's movement, may affect the accuracy of heart rate readings. The pulse sensor is intended only as an exercise aid in determining heart rate trends in general.
13. When you stop exercising, allow the pedals to slowly come to a complete stop. The elliptical exerciser does not have a free wheel; the pedals will continue to move until the flywheel stops.
14. Always unplug the power cord immediately after use and before cleaning the elliptical exerciser.
15. The decal shown below has been placed on the elliptical exerciser. If the decal is missing or illegible, please call our Customer Service Department toll-free at 1-888-825-2588 to order a free replacement decal. Apply the decal in the location shown.

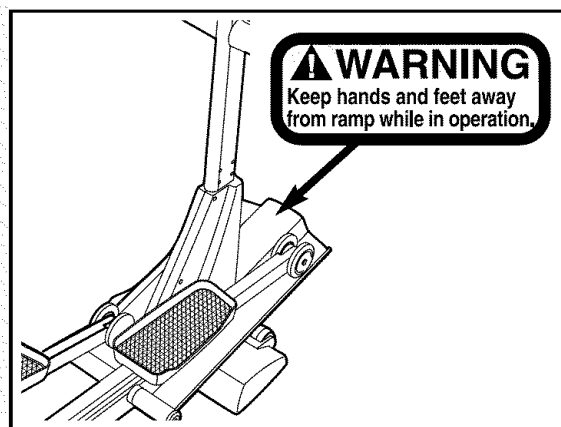

⚠ WARNING: Before beginning this or any exercise program, consult your physician. This is especially important for persons over the age of 35 or persons with pre-existing health problems. Read all instructions before using. ICON assumes no responsibility for personal injury or property damage sustained by or through the use of this product.

BEFORE YOU BEGIN

Congratulations for selecting the new NordicTrack® CX 985 elliptical exerciser. The CX 985 is an incredibly smooth exerciser that moves your feet in a natural elliptical path, minimizing the impact on your knees and ankles. And the unique CX 985 features adjustable resistance and incline to help you get the most from your exercise. Welcome to a whole new world of natural, elliptical-motion exercise from NordicTrack.



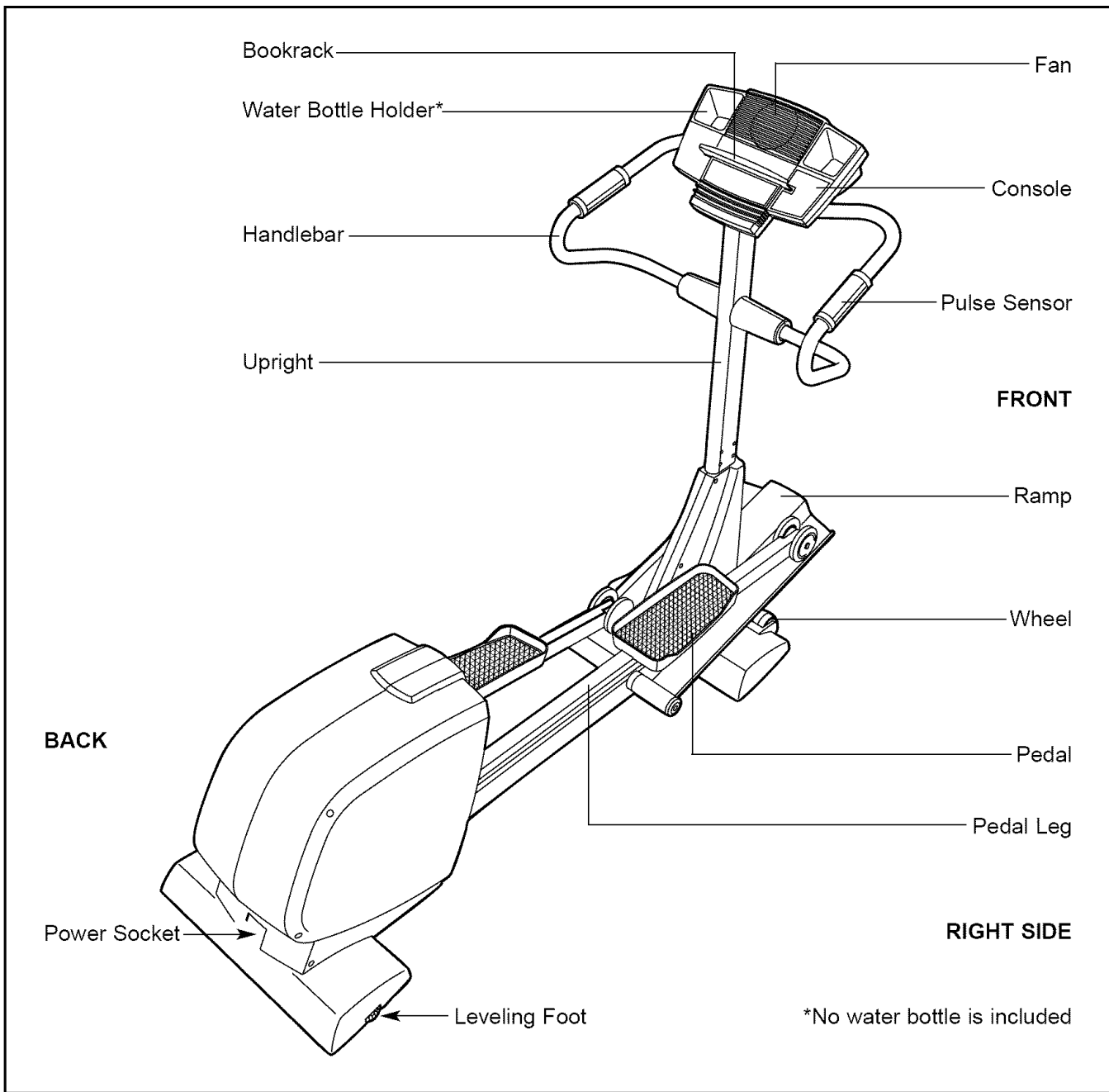

For additional questions, please call our Customer Service Department toll-free at 1-888-825-2588, Monday through Friday, 6 a.m. until 6 p.m. Mountain Time (excluding holidays). To help us assist you, please note the product model number and serial number before calling. The model number is NTE11920. The serial number can be found on a decal attached to the elliptical exerciser (see the front cover of this manual for the location of the decal).

For your benefit, read this manual carefully before you use the elliptical exerciser. If you have addi-

Before reading further, please familiarize yourself with the parts that are labeled in the drawing below.

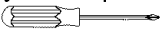

ASSEMBLY

Assembly requires two people. Place all parts of the elliptical exerciser in a cleared area and remove the packing materials. Do not dispose of the packing materials until assembly is completed. In addition to the four included allen wrenches, assembly requires a phillips screwdriver , two adjustable wrenches , a rubber mallet , and pliers .

As you assemble the elliptical exerciser, use the drawings below to identify the small parts used in assembly. The number in parenthesis below each drawing refers to the key number of the part, from the PART LIST on pages 24 and 25. The second number refers to the quantity used in assembly. **Note: Some small parts may have been pre-assembled. If a part is not in the parts bag, check to see if it is pre-assembled.**

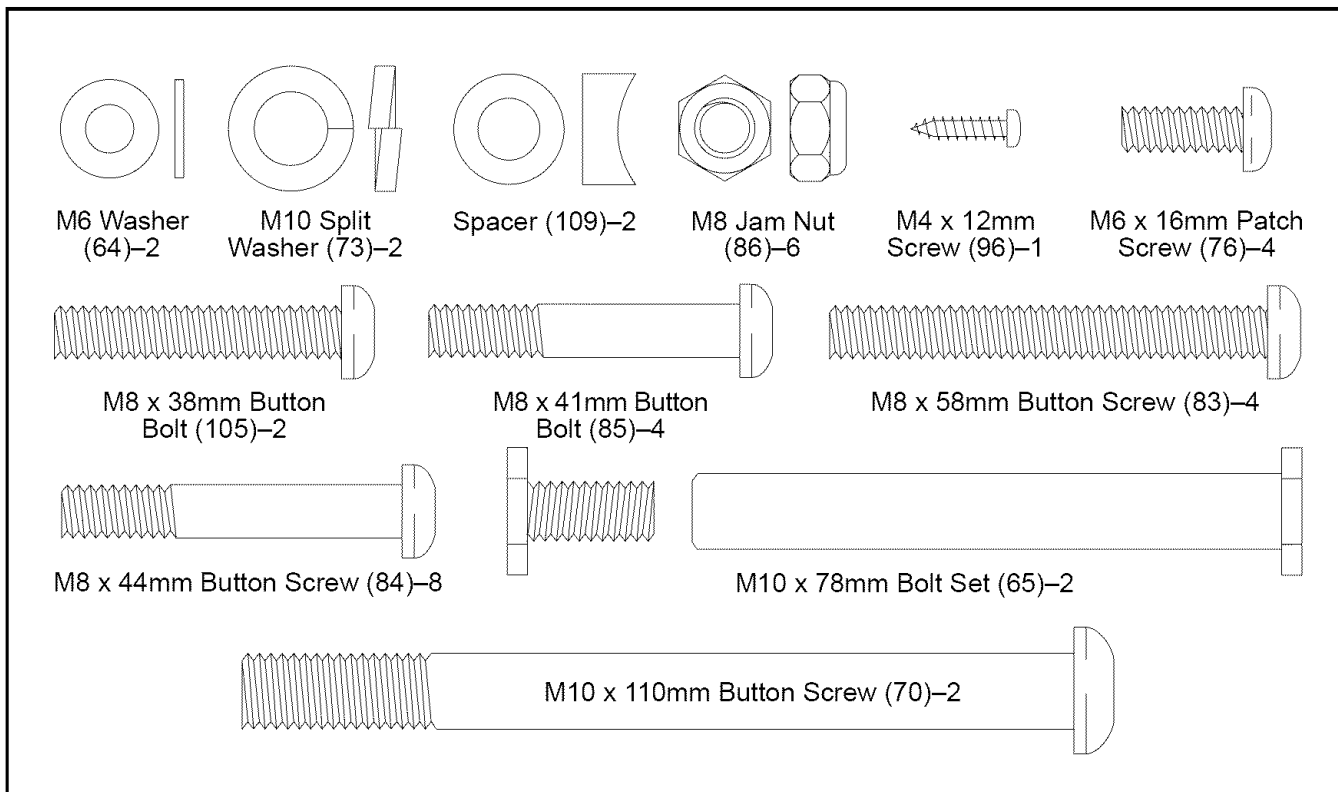

1. Identify the Front Stabilizer (8). While another person lifts the front of the Frame (1) and holds the Pedal Legs (4, 5) in the position shown, attach the Front Stabilizer to the Frame with four M8 x 44mm Button Screws (84) and a Support Plate (104) as shown.

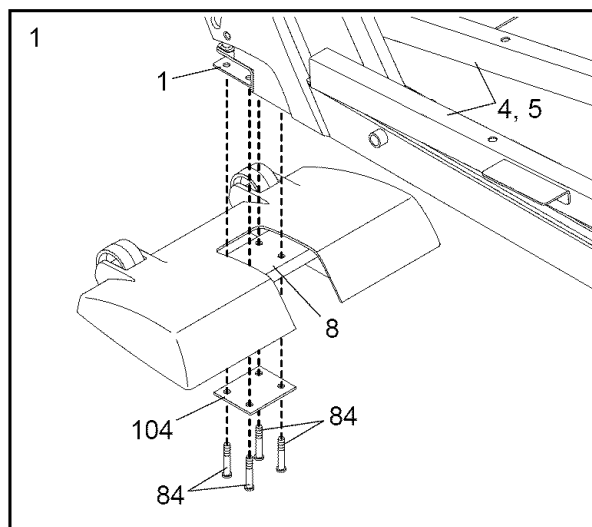

- While another person lifts the rear of the Frame (1), attach the Rear Stabilizer (6) to the Frame with four M8 x 44mm Button Screws (84) and a Support Plate (104) as shown.

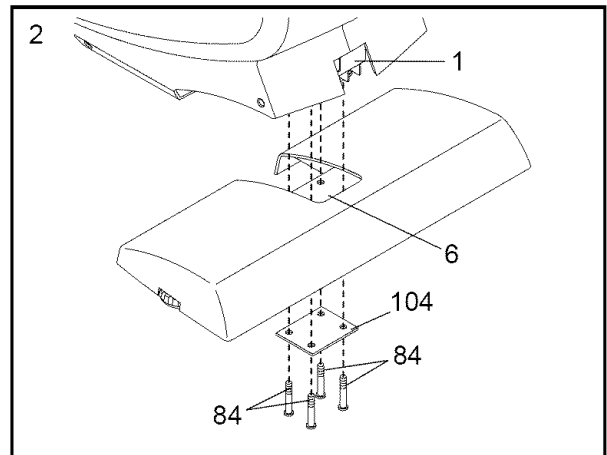

- Slide a Ramp Cover (48) onto an M6 x 16mm Patch Screw (76) as shown. Tighten the Patch Screw into one end of the Pivot Axle (14), which is the **longer** of the two axles. Apply a small amount of the included grease to the Pivot Axle.

Have a second person hold the two Ramp Spacers (99) against the sides of the Frame (1) so that they cover the indicated tubes on the Frame. Align the round tubes on the Ramp (3) with the Ramp Spacers.

Make sure that the Ramp is turned as shown in drawing 4 below. Insert the Pivot Axle (14) into the Ramp, the Ramp Spacers, and the Frame. If necessary, tap the Pivot Axle with a rubber mallet to insert it.

Slide a Ramp Cover (48) onto an M6 x 16mm Patch Screw (76) as shown. Tighten the Patch Screw into the open end of the Pivot Axle (14).

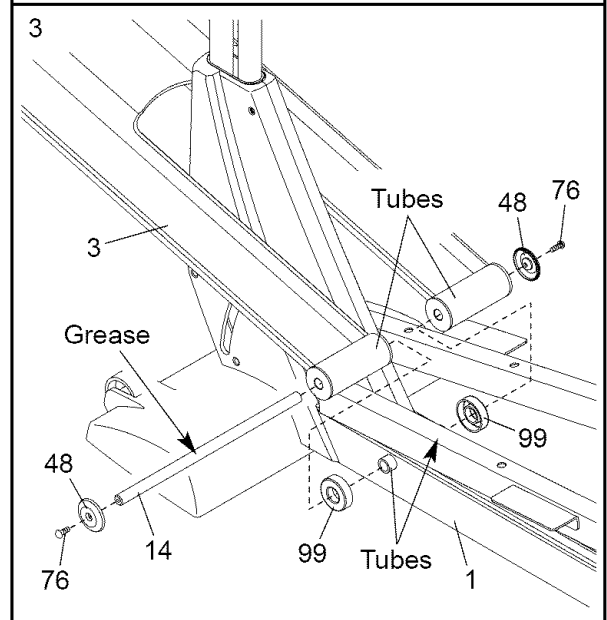

- Slide an M6 Washer (64) onto an M6 x 16mm Patch Screw (76). Tighten the Patch Screw into one end of the Incline Axle (13). Apply a small amount of grease to the Incline Axle.

Raise the Ramp (3). Insert the Incline Axle (13) into the welded tube under one side of the Ramp, through the motor screw, and then into the welded tube under the other side of the Ramp. **As you insert the Incline Axle through the motor screw, make sure that the motor screw does not turn.**

Slide an M6 Washer (64) onto an M6 x 16mm Patch Screw (76). Tighten the Patch Screw into the open end of the Incline Axle (13).

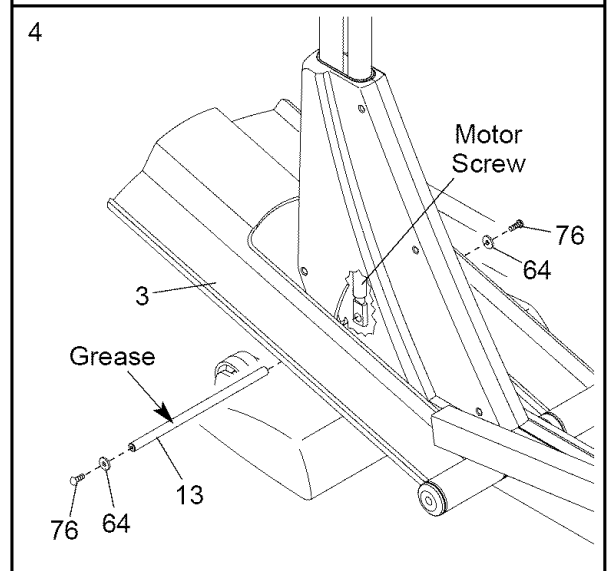

- Identify the Left Pedal (10). Attach the Left Pedal to the Left Pedal Leg (4) with two M8 x 58mm Button Screws (83).

Attach the Right Pedal (11) to the Right Pedal Leg (5) in the same way.

Attach two Pedal Wheels (28) and a Wheel Spacer (31) to the Wheel Frame (30) with an M10 x 78mm Bolt Set (65). **Make sure that the Bolt Set, Pedal Wheels, and Wheel Spacer are oriented as shown; the bushing in the Wheel Spacer (see the inset drawing) must be facing away from the Wheel Frame.**

Attach the other two Pedal Wheels and the other Wheel Spacer (not shown) to the Wheel Frame (not shown) on the Right Pedal Leg (5) in the same way.

- Have another person hold the Upright (2) in the position shown. **Make sure that the Upright is turned as shown in drawing 7 below.**

Connect the Upper Wire Harness (115) to the Lower Wire Harness (42). **Carefully pull the upper end of the Upper Wire Harness to remove the slack from the Wire Harnesses.** Insert the Upright (2) into the Frame (1). **Be careful to avoid disconnecting or pinching the Wire Harnesses.** Attach the Upright with two M10 x 110mm Button Screws (70), two M10 Split Washers (73), and two Spacers (109); **make sure that the curved sides of the Spacers are facing the Upright. Be careful to avoid damaging the Wire Harnesses with the Button Screws.**

- Have another person hold the Left Handlebar (24) near the Upright (2) as shown. Connect the left Pulse Sensor Wire (20) to the Pulse Extension Wire (114).

Slide the upper end of the Left Handlebar (24) into the tube on the front of the Upright (2), while sliding the lower end of the Left Handlebar onto the tube on the left side of the Upright. Attach the upper end of the Left Handlebar with two M8 x 41mm Button Bolts (85) and two M8 Jam Nuts (86); **be careful not to damage the Pulse Sensor Wire (20) or the Pulse Extension Wire (114) as you insert the Button Bolts. Make sure that the Jam Nuts are resting in the hexagonal holes in the Left Handlebar.** Attach the lower end of the Left Handlebar with an M8 x 38mm Button Bolt (105) and an M8 Jam Nut (86).

Attach the Right Handlebar (23) to the Upright (2) in the same way.

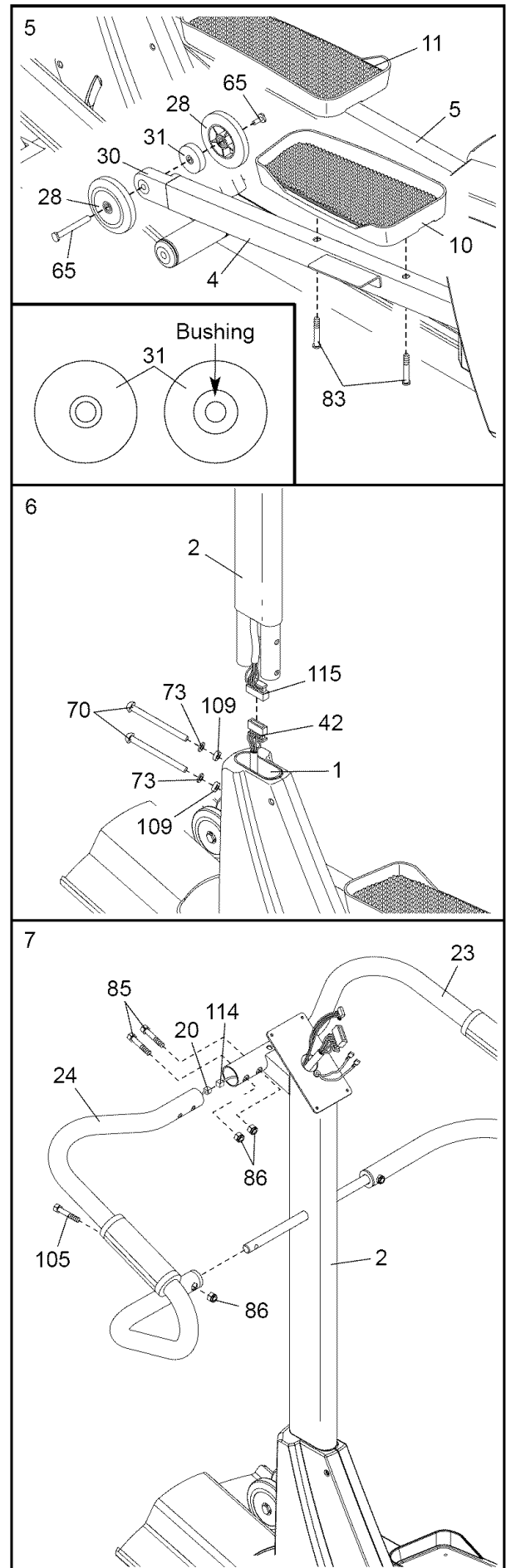

8. Locate one of the Handlebar Covers (26). Look inside of the Handlebar Cover and locate the square tabs connecting the two halves. Gently lift the tabs and disconnect the halves.

Hold the two halves of the Handlebar Cover (26) around the tube on the left side of the Upright (2). Align the halves and press them together until they lock.

Attach the other Handlebar Cover (26) to the right side of the Upright (2) in the same way.

Hold the halves of the Upper Handlebar Cover (25) around the tube on the front of the Upright (2); **be careful not to damage the Pulse Sensor Wires or the Pulse Extension Wire (not shown)**. Attach the Upper Handlebar Cover with an M4 x 12mm Screw (96).

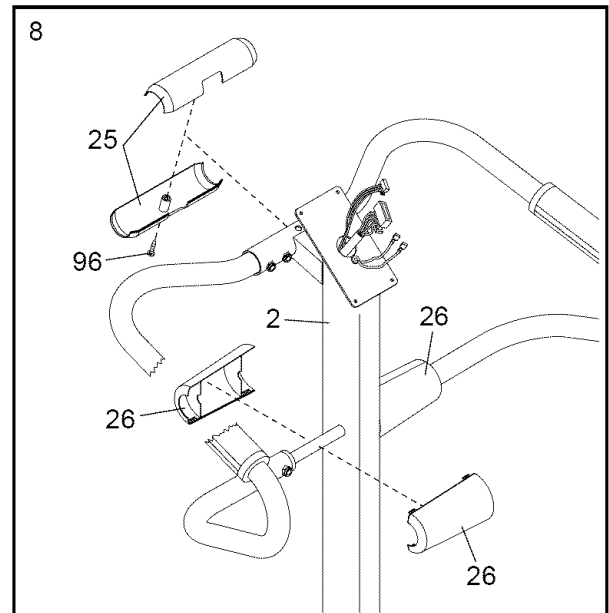

9. Have another person hold the Console (17) near the Upright (2).

Connect the Upper Wire Harness (115) to the wire harness on the Console (17). Connect the Pulse Extension Wire (114) to the pulse wire on the Console. Next, locate the two ground wires that are attached with a screw to the Upright (2). Connect the ground wires to the two smallest wires on the Console.

Carefully insert all excess wiring up into the Console (17) and down into the Upright (2). Attach the Console to the Upright with four M4 x 16mm Screws (98). (Note: The Screws may be shipped in the console box.) **Be careful to avoid pinching the wires.**

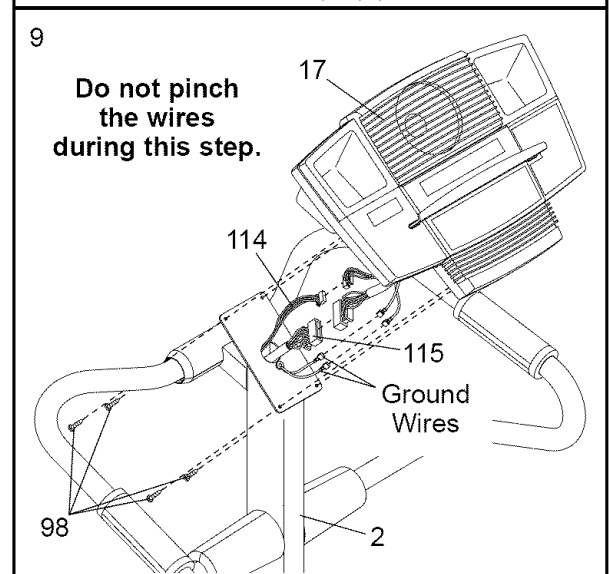

10. Plug the Power Cord (116) into the Power Socket (117) at the rear of the elliptical exerciser.

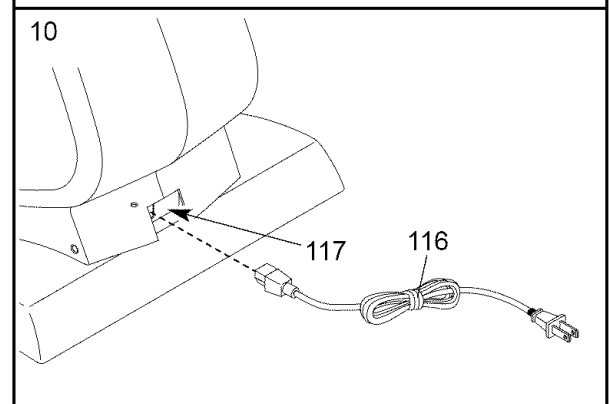

11. **Make sure that all parts of the elliptical exerciser are properly tightened.** Cover the floor beneath the elliptical exerciser to protect the floor from damage. Note: Some extra hardware may be left over.

The elliptical exerciser is now fully assembled. If you have purchased the optional chest pulse sensor (see page 21), refer to page 9 of this manual.

INSTALLING THE RECEIVER FOR THE OPTIONAL CHEST PULSE SENSOR

If you have purchased the optional chest pulse sensor (see page 21), follow the steps below to install the receiver included with the optional chest pulse sensor.

1. Look under the Console (17) and locate the access cover. Remove the access cover.
2. Hold the receiver in the position shown, with the small cylinder at the top. Using the two screws included with the chest pulse sensor, attach the receiver to the two plastic posts (not shown) inside the access opening in the back of the Console (17).
3. Connect the wire on the receiver to the indicated wire on the Console (17). Make sure that the connectors on the wires snap together. Discard the other wires included with the chest pulse sensor.
4. Reattach the access cover to the Console (17).

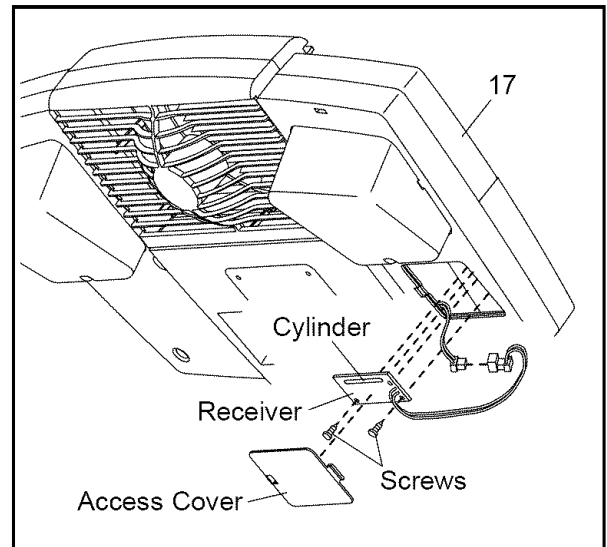

HOW TO USE THE ELLIPTICAL EXERCISER

HOW TO PLUG IN THE POWER CORD

This product must be grounded. If it should malfunction or break down, grounding provides a path of least resistance for electric

current to reduce the risk of electric shock. This product is equipped with a cord having an equipment-grounding conductor and a grounding plug. **Plug the power cord into an appropriate outlet that is properly installed and grounded in accordance with all local codes and ordinances. This product is for use on a nominal 120-volt circuit. Important: The elliptical exerciser is not compatible with GFCI-equipped outlets.**

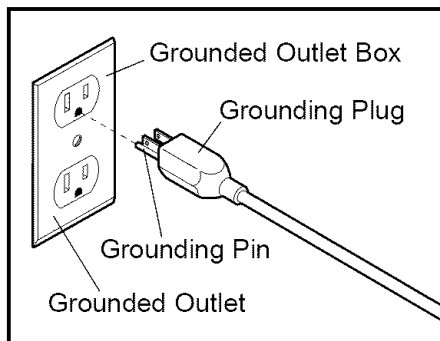

The green-colored rigid ear, lug, or the like extending from the adapter must be connected to a permanent ground such as a properly grounded outlet box cover. Whenever the adapter is used, it must be held in place by a metal screw. **Some 2-pole receptacle outlet box covers are not grounded. Contact a qualified electrician to determine if the outlet box cover is grounded before using an adapter.**

Note: When the power cord is plugged in, the elliptical exerciser's incline system may automatically calibrate itself. During the calibration process, two dashes (--) will appear in the left display of the console and the ramp will move to the highest position and then return to the lowest position. The calibration process will last for one to two minutes.

EXERCISING ON THE ELLIPTICAL EXERCISER

To mount the elliptical exerciser, hold the handlebars and step onto the pedal that is in the lowest position. Next, step onto the other pedal. Push the pedals until they begin to move with a continuous motion.

⚠ DANGER: Improper connection of the equipment-grounding conductor can result in an increased risk of electric shock. Check with a qualified electrician or serviceman if you are in doubt as to whether the product is properly grounded. Do not modify the plug provided with the product—if it will not fit the outlet, have a proper outlet installed by a qualified electrician.

A temporary adapter may be used to connect the power cord to a 2-pole receptacle as shown at the right if a properly grounded outlet is not available. The temporary adapter should be used only until a properly grounded outlet can be installed by a qualified electrician.

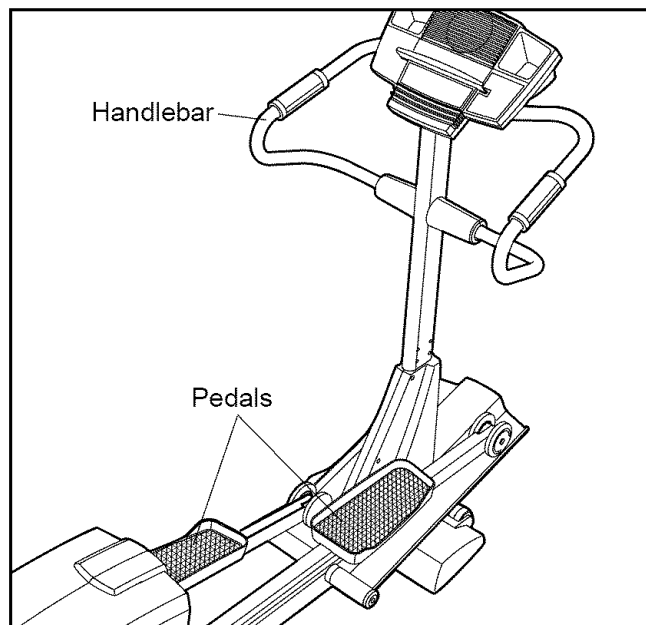
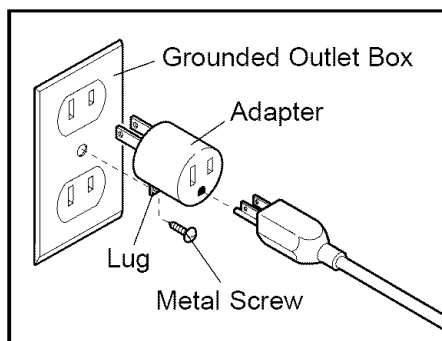

To dismantle the elliptical exerciser, wait until the pedals come to a complete stop. **The elliptical exerciser does not have a free wheel; the pedals will continue to move until the flywheel stops.** When the pedals are stationary, step off the highest pedal first. Then, step off the lowest pedal.

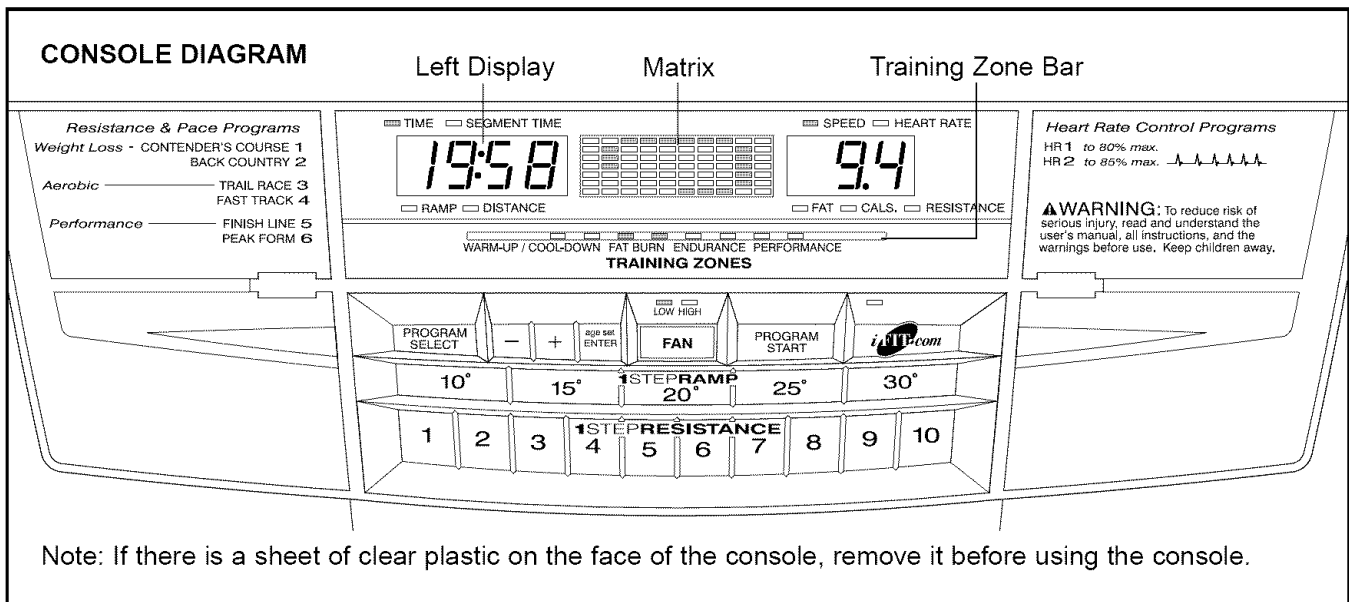

FEATURES OF THE CONSOLE

The advanced console offers a selection of features designed to make your workouts more enjoyable and effective. When the manual mode of the console is selected, the resistance of the elliptical exerciser and the angle of the ramp can be changed with the touch of a button. As you exercise, the console will provide continuous exercise feedback. You can even measure your heart rate using the handgrip pulse sensor. Note: **For information about an optional chest pulse sensor, see page 21.**

The console also offers six resistance and pace programs. Each program automatically changes the resistance of the elliptical exerciser and prompts you to increase or decrease your pace as it guides you through an effective workout.

In addition, the console features two heart rate programs that automatically change the resistance of the elliptical exerciser and prompt you to vary your pace to keep your heart rate near a target level as you exercise.

The console also features new iFIT.com interactive

technology. Having iFIT.com technology is like having a personal trainer in your home. Using the included audio cable, you can connect the elliptical exerciser to your home stereo, portable stereo, or computer and play special iFIT.com CD programs (CD's are available separately). iFIT.com CD programs automatically control the resistance of the elliptical exerciser and prompt you to vary your pace as a personal trainer coaches you through every step of your workout. High-energy music provides added motivation. Each CD features two programs designed by certified personal trainers.

In addition, you can connect the elliptical exerciser to your VCR and TV and play iFIT.com video programs (videocassettes are available separately). Video programs offer the same benefits as iFIT.com CD programs, and add the excitement of working out with a class and an instructor.

With the elliptical exerciser connected to your computer, you can also go to our Web site at www.iFIT.com and access programs directly from the internet. Explore www.iFIT.com for details.

To purchase iFIT.com CD's and videocassettes, call toll-free 1-800-735-0768.

HOW TO USE THE MANUAL MODE

1 Press any button on the console or begin pedaling to turn on the console.

Make sure that the power cord is properly plugged in (see page 10). Next, press any button on the console or begin pedaling to turn on the console. After a few seconds, the console displays will light. A tone will then sound and the console will be ready for use.

2 Select the manual mode.

When the power is turned on, the manual mode will be selected. If you have selected a program or the iFIT.com mode, select the manual mode by pressing the Program Select button repeatedly until a track appears in the matrix.

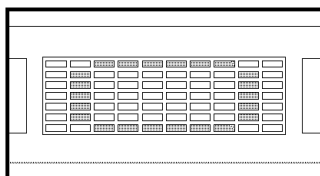

3 Begin pedaling and change the resistance of the elliptical exerciser as desired.

As you pedal, change the resistance of the elliptical exerciser by pressing the Resistance buttons. There are ten resistance levels. Note: After the Resistance buttons are pressed, it will take a moment for the elliptical exerciser to reach the selected resistance level.

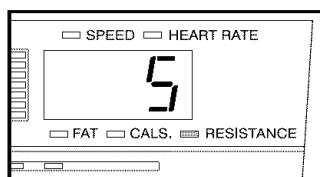

4 Adjust the angle of the ramp as desired.

As you pedal, change the angle of the ramp by pressing the Ramp buttons. There are five ramp angles. Note: After the Ramp buttons are pressed, it will take a moment for the ramp to reach the selected angle.

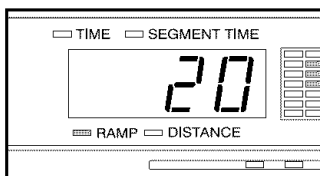

5 Monitor your progress with the matrix, the Training Zone bar, and the two displays.

The matrix—

When the manual mode or the iFIT.com mode is selected, the matrix will show a track representing 1/4 mile. As you exercise, the indicators around the track will light, one at a time, until the entire track is lit. When you have completed a lap, a new lap will begin.

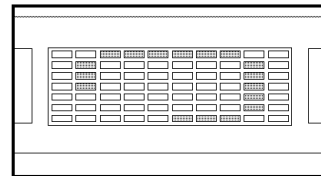

The Training Zone bar—

The Training Zone bar will show your pace and the approximate intensity level of your exercise. For example, if three or four indicators in the bar are lit, the bar shows that your pace is ideal for fat burning. During programs, the Training Zone bar will also prompt you to increase or decrease your pace.

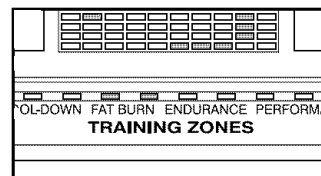

The left display—

The left display will show the elapsed time, the angle of the ramp, and the distance you have pedaled. The display will change from one number to the next every few seconds, as shown by the indicators around the display. Note: When a program is selected, the display will show the time remaining in the program and the time remaining in the current segment of the program instead of the elapsed time.

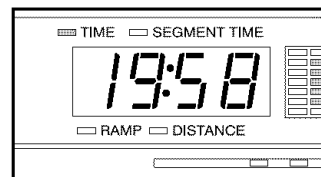

The right display—

The right display will show your pedaling speed, the approximate numbers of fat calories and calories you have burned (see FAT BURNING on page 23), and the resistance level of the elliptical exerciser. The display will change from one number to the next every few seconds, as shown by the indicators around the display. The display will also show your heart rate when you use the handgrip pulse sensor or the optional chest pulse sensor.

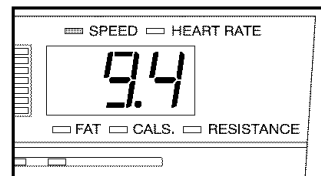

Note: The console can display speed and distance in either miles or kilometers. To find which unit of measurement is selected, you must select the console's user mode. Hold down the Program Select button for about three seconds. The letter "E" for English miles or the letter "M" for metric kilometers will appear in the left display. To change the unit of measurement, press the + button.

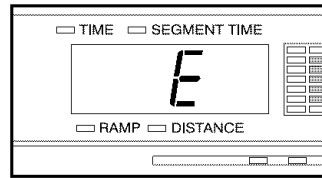

While the user mode is selected, press the Program Start button. The left display will then show the total number of hours that the elliptical exerciser has been used. Press the Program Start button again. The left display will then show the total number of miles pedaled. To exit the user mode, press the Program Select button again.

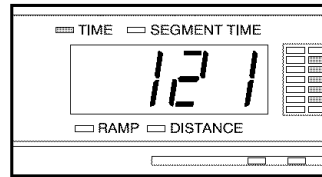

6 Measure your heart rate if desired.

Note: If you hold the handgrip pulse sensor and wear the optional chest pulse sensor at the same time, the console may not display your heart rate accurately.

If there are thin sheets of plastic on the metal contacts on the handgrip pulse sensor, peel off the plastic. To measure your heart rate, hold the contacts; your palms must be resting on the upper contacts, and your fingers must be touching the lower contacts. **Avoid moving your hands.**

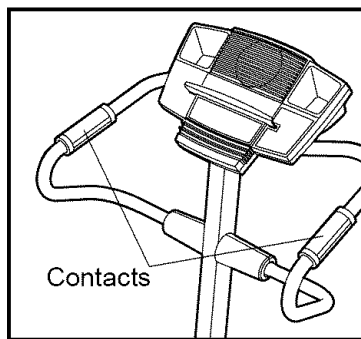

When your pulse is detected, the Heart Rate indicator above the right display will begin to flash, one or two dashes (—) will appear in the right display, and then your heart rate will be shown. For the most accurate heart rate reading, hold the contacts for at least 15 seconds.

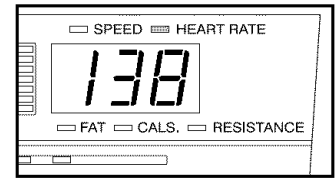

Note: If you continue to hold the pulse sensor, the right display will show your heart rate for up to 30 seconds. The display will then show your heart rate along with the other modes.

If your heart rate is not shown, make sure that your hands are positioned as described. Be careful not to move your hands excessively or to squeeze the metal contacts too tightly. For optimal performance, clean the metal contacts using a soft cloth; never use alcohol, abrasives, or chemicals.

7 Turn on the fan if desired.

To turn on the fan at low speed, press the Fan button. Pivot the fan to the desired angle. To turn on the fan at high speed, press the Fan button a second time. To turn off the fan, press the Fan button a third time.

8 When you are finished exercising, the console will automatically turn off.

If the pedals are not moved for several seconds, a tone will sound, the console will pause, and the left display will begin to flash.

If the pedals are not moved for about five minutes, the console will turn off and the displays will be reset.

HOW TO USE RESISTANCE AND PACE PROGRAMS

- 1 Press any button on the console or begin pedaling to turn on the console.

See step 1 on page 12.

- 2 Select one of the six resistance and pace programs.

When the power is turned on, the manual mode will be selected. To select a resistance and pace program, press the Program

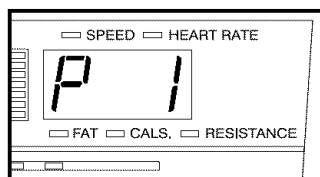

Select button repeatedly until a "P 1," "P 2," "P 3," "P 4," "P 5," or "P 6" appears in the right display.

When a resistance and pace program is selected, the matrix will show the first seven pace settings for the program. The left display will show how long the program will last.

- 3 Press the Program Start button or begin pedaling to start the program.

Each program is divided into several time segments of different lengths. One pace setting and one resistance setting are programmed for each segment. (The same pace setting and/or resistance setting may be programmed for two or more consecutive segments.)

The pace setting for the first segment will be shown in the flashing Current Segment column of the matrix. (The resistance settings are not shown in the matrix.) The pace settings for the next several segments will be shown in the columns to the right.

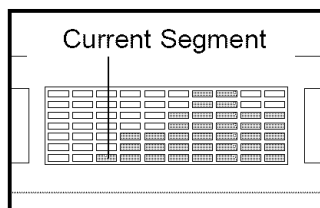

As you exercise, the Training Zone bar will help you to keep your pedaling pace near the pace

setting for the current segment. The lit indicators in the bar will show your actual pace. If an indicator to the right of the lit indicators is flashing (see drawing a), increase your pace. If an indicator to the left of any lit indicator is flashing (see drawing b), decrease your pace. When no indicator is flashing, your pace matches the pace setting for the current segment. **Important: The pace settings are intended only to provide motivation. Your actual pace may be slower than the current pace setting. Make sure to exercise at a pace that is comfortable for you.**

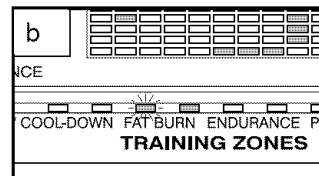
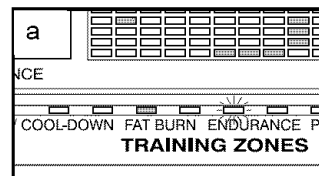

When only three seconds remain in the first segment of the program, both the Current Segment column and the column to the right will flash, a series of tones will sound, and *all pace settings will move one column to the left*. The pace setting for the second segment will then be shown in the flashing Current Segment column and the resistance of the elliptical exerciser will automatically change to the resistance setting for the second segment.

Note: If all of the indicators in the Current Segment column are lit after the pace settings have moved to the left, *the pace settings will move downward* so that only the highest indicators appear in the matrix.

The program will continue until the pace setting for the last segment is shown in the Current Segment column of the matrix and no time remains in the program.

Note: During the program, you can override the resistance setting for the current segment, if desired, by pressing the Resistance buttons. However, when the next segment begins, the resistance will automatically change if a different resistance is programmed for the next segment. If you stop pedaling for several seconds, a tone will sound and the program will pause. To restart the program, simply resume pedaling.

4 Adjust the angle of the ramp as desired.

See step 4 on page 12.

5 Monitor your progress with the two displays.

See step 5 on page 12.

6 Measure your heart rate if desired.

See step 6 on page 13.

7 Turn on the fan if desired.

See step 7 on page 13.

8 When the program is finished, the console will automatically turn off.

See step 8 on page 13.

HOW TO USE HEART RATE PROGRAMS

Each heart rate program helps you to keep your heart rate near a certain *percentage* of your *maximum heart rate* during your workout. (Your maximum heart rate is estimated by subtracting your age from 220. For example, if you are 30 years old, your maximum heart rate is 190.) Heart rate program 1 is designed to keep your heart rate between 50% and 80% of your maximum heart rate while you exercise; heart rate program 2 is designed to keep your heart rate between 50% and 85% of your maximum heart rate.

Follow the steps below to use a heart rate program.

1 Press any button on the console or begin pedaling to turn on the console.

See step 1 on page 12.

2 Select one of the heart rate programs.

When the power is turned on, the manual mode will be selected. To select a heart rate program, press the Program Select button repeatedly until an "H 1" or "H 2" appears in the right display.

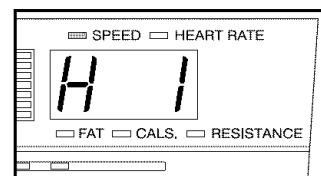

3 Enter your age.

When a heart rate program is selected, the word "AGE" and the current age setting will flash in the left display. You must enter your age to use a heart rate program. If you have already entered your age, press the Age Set Enter button and go to step 4. If you have not entered your age, press the + or - button repeatedly to enter your age, and then press the Age Set Enter button.

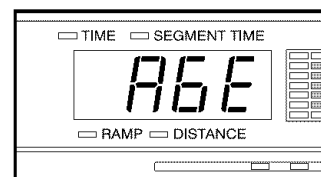

Once you have entered your age, it will be saved in memory.

4 Hold the handgrip pulse sensor.

To use a heart rate program, you must use the handgrip pulse sensor (see step 6 on page 13) or the optional chest pulse sensor. If you use the handgrip pulse sensor, it is not necessary to hold the handgrips continuously during the program. However, you should hold the handgrips frequently for the program to operate properly. **Each time you hold the handgrips, keep your hands on the metal contacts for at least 30 seconds.** Note: When you are not holding the handgrips, the letters "PLS" will appear in the right display instead of your heart rate.

5 Press the Program Start button or begin pedaling to start the program.

Each heart rate program consists of 20 one-minute segments. One resistance setting and one heart rate setting are programmed for each segment. (The same resistance setting and/or heart rate setting may be programmed for two or more consecutive segments.)

The resistance setting for the first segment will be shown in the flashing Current Segment column of the matrix. The resistance settings for the next several segments will be shown in the columns to the right.

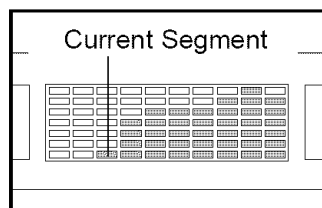

When only three seconds remain in the first segment of the program, both the Current Segment column and the column to the right will flash, a series of tones will sound, and *all resistance settings will move one column to the left*. The resistance setting for the second segment will then be shown in the flashing Current Segment column and the resistance of the elliptical exerciser will automatically adjust to the resistance setting for the second segment.

As you exercise, the Training Zone bar will help you to keep your heart rate near the heart rate setting for the current segment. The lit indicators in the bar will show your actual pace. When you hold the handgrip pulse sensor or wear the optional chest pulse sensor, the console will periodically

compare your heart rate to the heart rate setting for the current segment; if necessary, an indicator in the bar will then flash to prompt you to increase or decrease your pace to bring your heart rate closer to the current heart rate setting.

If an indicator to the *right* of the lit indicators is flashing (see drawing a), increase your pace. If an indicator to the *left* of any lit indicator is flashing (see drawing b), decrease your pace. When no indicator is flashing, your heart rate is near the current heart rate setting.

Important: The heart rate settings are intended only to provide motivation. Your actual heart rate may be slower than the current heart rate setting. Make sure to exercise at a pace that is comfortable for you.

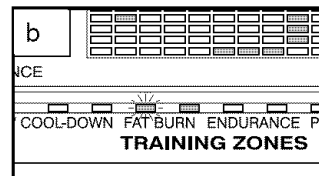
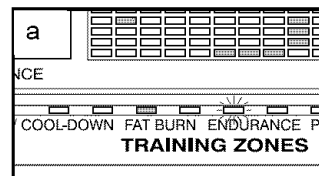

The program will continue until the resistance setting for the last segment is shown in the Current Segment column of the matrix and no time remains in the program.

Note: During the program, you can manually override the resistance setting for the current segment, if desired, with the Resistance buttons. However, when the next segment begins, the elliptical exerciser will automatically adjust to the resistance setting for the next segment. If you stop pedaling for several seconds, a tone will sound and the program will pause. To restart the program, simply resume pedaling.

6 Monitor your progress with the two displays.

See step 5 on page 12.

7 Turn on the fan if desired.

See step 7 on page 13.

8 When the program is finished, the console will automatically turn off.

See step 8 on page 13.

HOW TO CONNECT YOUR CD PLAYER, VCR, OR COMPUTER

To use iFIT.com CD's, the elliptical exerciser must be connected to your portable CD player, portable stereo, home stereo, or computer with CD player. See pages 17 and 18 for connecting instructions. To use iFIT.com videocassettes, the elliptical exerciser must be connected to your VCR. See page 19 for connecting instructions. To use iFIT.com programs directly from our Web site, the elliptical exerciser must be connected to your home computer. See page 18 for connecting instructions.

HOW TO CONNECT YOUR PORTABLE CD PLAYER

Note: If your CD player has separate LINE OUT and PHONES jacks, see instruction A below. If your CD player has only one jack, see instruction B.

- A. Plug one end of the audio cable into the jack beneath the console. Plug the other end of the cable into the LINE OUT jack on your CD player. Plug your headphones into the PHONES jack.

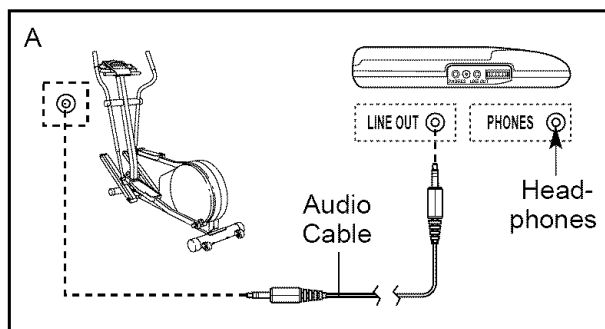

- B. Plug one end of the audio cable into the jack beneath the console. Plug the other end of the cable into a 1/8" Y-adapter (available at electronics stores). Plug the Y-adapter into the PHONES jack on your CD player. Plug your headphones into the other side of the Y-adapter.

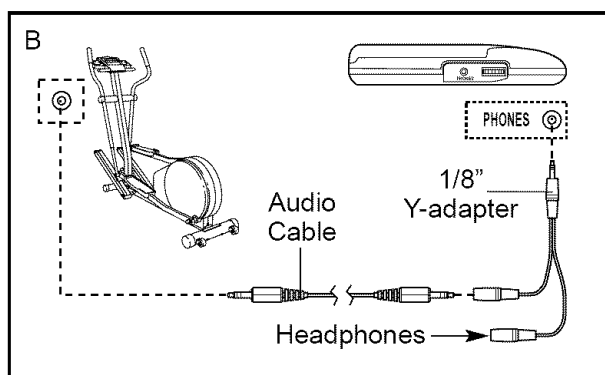

HOW TO CONNECT YOUR PORTABLE STEREO

Note: If your stereo has an RCA-type AUDIO OUT jack, see instruction A below. If your stereo has a 1/8" LINE OUT jack, see instruction B. If your stereo has only a PHONES jack, see instruction C.

- A. Plug one end of the audio cable into the jack beneath the console. Plug the other end of the cable into the adapter. Plug the adapter into an AUDIO OUT jack on your stereo.

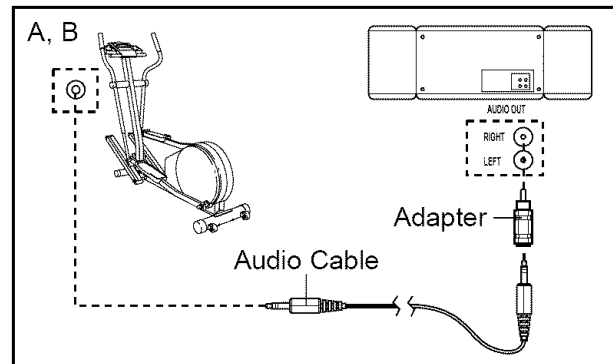

- B. Plug one end of the audio cable into the jack beneath the console. Plug the other end of the cable into the LINE OUT jack on your stereo. Do not use the adapter.

- C. Plug one end of the audio cable into the jack beneath the console. Plug the other end of the cable into a 1/8" Y-adapter (available at electronics stores). Plug the Y-adapter into the PHONES jack on your stereo. Plug your headphones into the other side of the Y-adapter.

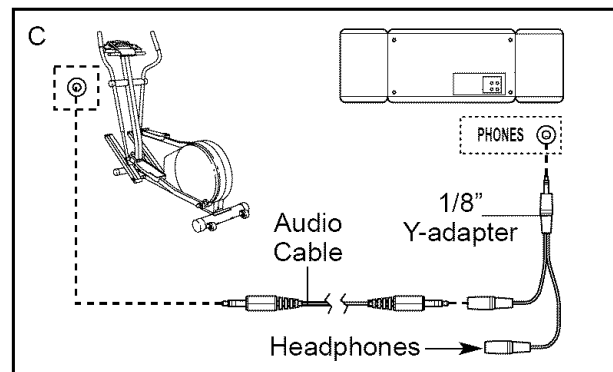

HOW TO CONNECT YOUR HOME STEREO

Note: If your stereo has an unused LINE OUT jack, see instruction A below. If the LINE OUT jack is being used, see instruction B.

- A. Plug one end of the audio cable into the jack beneath the console. Plug the other end of the cable into the adapter. Plug the adapter into the LINE OUT jack on your stereo.

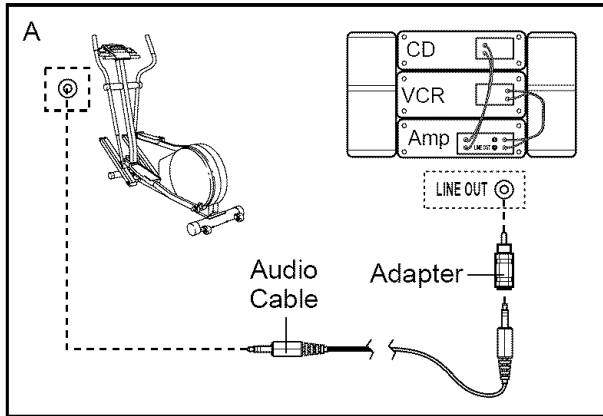

- B. Plug one end of the audio cable into the jack beneath the console. Plug the other end of the cable into the adapter. Plug the adapter into an RCA Y-adapter (available at electronics stores). Next, remove the wire that is currently plugged into the LINE OUT jack on your stereo and plug the wire into the unused side of the Y-adapter. Plug the Y-adapter into the LINE OUT jack on your stereo.

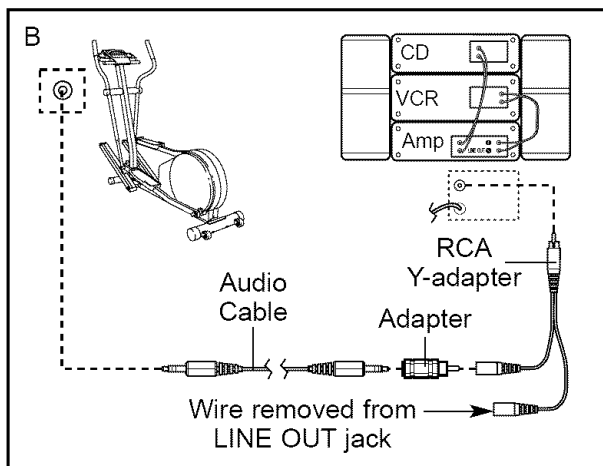

HOW TO CONNECT YOUR COMPUTER

Note: If your computer has a 1/8" LINE OUT jack, see instruction A. If your computer has only a PHONES jack, see instruction B.

- A. Plug one end of the audio cable into the jack beneath the console. Plug the other end of the cable into the LINE OUT jack on your computer.

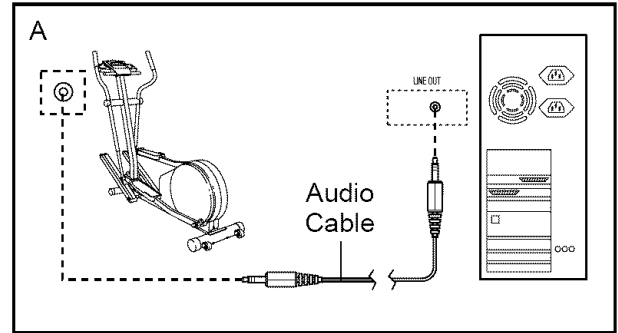

- B. Plug one end of the audio cable into the jack beneath the console. Plug the other end of the cable into a 1/8" Y-adapter (available at electronics stores). Plug the Y-adapter into the PHONES jack on your computer. Plug your headphones or speakers into the other side of the Y-adapter.

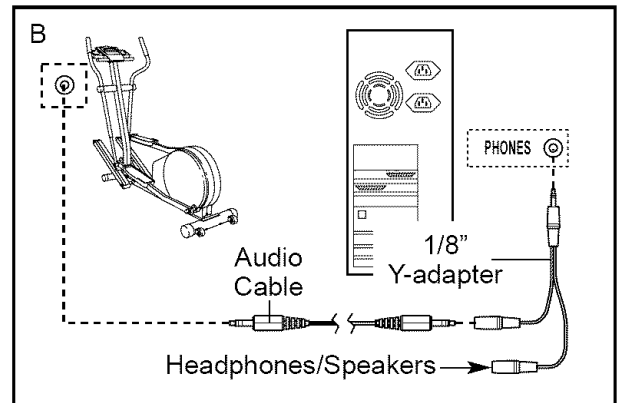

HOW TO CONNECT YOUR VCR

Note: If your VCR has an unused AUDIO OUT jack, see instruction A below. If the AUDIO OUT jack is being used, see instruction B. If you have a TV with a built-in VCR, see instruction B. If your VCR is connected to your home stereo, see HOW TO CONNECT YOUR HOME STEREO on page 18.

- A. Plug one end of the audio cable into the jack beneath the console. Plug the other end of the cable into the adapter. Plug the adapter into the AUDIO OUT jack on your VCR.

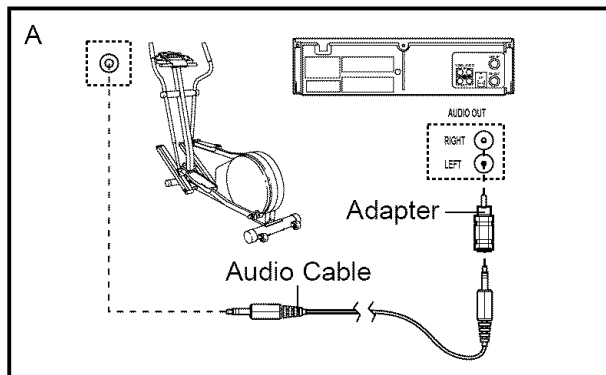

- B. Plug one end of the audio cable into the jack beneath the console. Plug the other end of the cable into the adapter. Plug the adapter into an RCA Y-adapter (available at electronics stores). Next, remove the wire that is currently plugged into the AUDIO OUT jack on your VCR and plug the wire into the unused side of the Y-adapter. Plug the Y-adapter into the AUDIO OUT jack on your VCR.

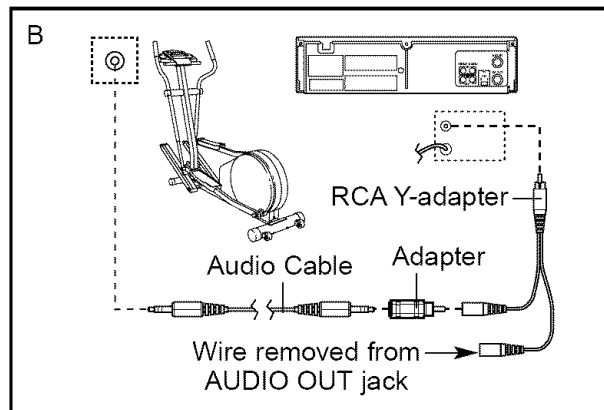

HOW TO USE iFIT.COM CD AND VIDEO PROGRAMS

To use iFIT.com CD's or videocassettes, the elliptical exerciser must be connected to your portable CD player, portable stereo, home stereo, computer with CD player, or VCR. See HOW TO CONNECT YOUR CD PLAYER, VCR, OR COMPUTER on page 17. **To purchase iFIT.com CD's and videocassettes, call toll-free 1-800-735-0768.**

Follow the steps below to use an iFIT.com CD or video program.

1 Press any button on the console or begin pedaling to turn on the console.

See step 1 on page 12.

2 Select the iFIT.com mode.

When the console is turned on, the manual mode will be selected. To select the iFIT.com mode, press the iFIT.com button.

The indicator above the button will light.

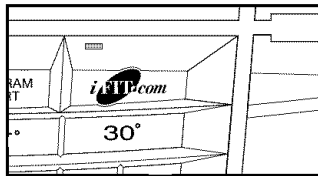

3 Insert the iFIT.com CD or videocassette.

If you are using an iFIT.com CD, insert the CD into your CD player. If you are using an iFIT.com videocassette, insert the videocassette into your VCR.

4 Press the play button on your CD player or VCR.

A moment after the play button is pressed, your personal trainer will begin guiding you through

your workout. Simply follow your personal trainer's instructions.

The program will function in almost the same way as a resistance and pace program (see step 3 on page 14). However, an electronic "chirping" sound will alert you when the resistance setting and/or the pace setting is about to change.

Note: If the resistance of the elliptical exerciser and/or the pace setting does not change when a "chirp" is heard:

- **Make sure that the indicator above the iFIT.com button is lit.**
- **Adjust the volume of your CD player or VCR. If the volume is too high or too low, the console may not detect the program signals.**
- **Make sure that the audio cable is properly connected and that it is fully plugged in.**

5 Monitor your progress with the two displays.

See step 5 on page 12.

6 Measure your heart rate if desired.

See step 6 on page 13.

7 Turn on the fan if desired.

See step 7 on page 13.

8 When the program is finished, the console will automatically turn off.

See step 8 on page 13.

HOW TO USE PROGRAMS DIRECTLY FROM OUR WEB SITE

Our Web site at www.iFIT.com allows you to play iFIT.com audio and video programs directly from the internet. To use programs from our Web site, the elliptical exerciser must be connected to your home computer. See HOW TO CONNECT YOUR COMPUTER on page 18. In addition, you must have an internet connection and an internet service provider. A list of specific system requirements is found on our Web site.

Follow the steps below to use a program from our Web site.

- 1 Press any button on the console or begin pedaling to turn on the console.**

See step 1 on page 12.

- 2 Select the iFIT.com mode.**

When the console is turned on, the manual mode will be selected. To select the iFIT.com mode, press the iFIT.com button.

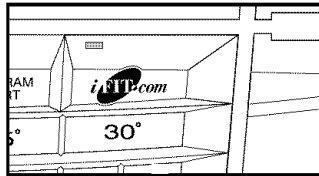

The indicator above the button will light.

- 3 Go to your computer and start an internet connection.**

- 4 Start your Web browser, if necessary, and go to our Web site at www.iFIT.com.**

- 5 Follow the desired links on our Web site to select a program.**

Read and follow the on-line instructions for using a program.

- 6 Follow the on-line instructions to start the program.**

When you start the program, an on-screen countdown will begin.

- 7 Return to the elliptical exerciser and begin pedaling.**

When the on-screen countdown ends, the program will begin. The program will function in almost the same way as a resistance and pace program (see step 3 on page 14). However, an electronic “chirping” sound will alert you when the resistance setting and/or the pace setting is about to change.

- 8 Monitor your progress with the two displays.**

See step 5 on page 12.

- 9 Measure your heart rate if desired.**

See step 6 on page 13.

- 10 Turn on the fan if desired.**

See step 7 on page 13.

- 11 When you are finished exercising, the console will automatically turn off.**

See step 8 on page 13.

THE OPTIONAL CHEST PULSE SENSOR

The optional chest pulse sensor provides hands-free operation and continuously monitors your heart rate during your workouts. **To purchase the optional chest pulse sensor, call toll-free 1-800-734-2377.**

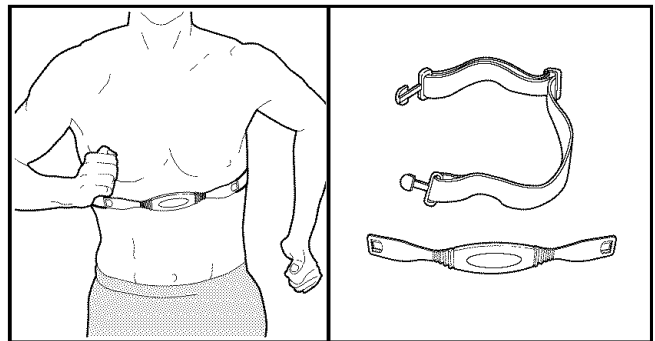

MAINTENANCE AND TROUBLESHOOTING

Inspect and properly tighten all parts of the elliptical exerciser regularly. Replace any worn parts immediately.

For smooth operation of the elliptical exerciser, **inspect and clean the incline ramp regularly** using a soft cloth and mild detergent. Other parts of the elliptical exerciser can also be cleaned in this way. **Keep liquids off the console. Never use abrasives or solvents.**

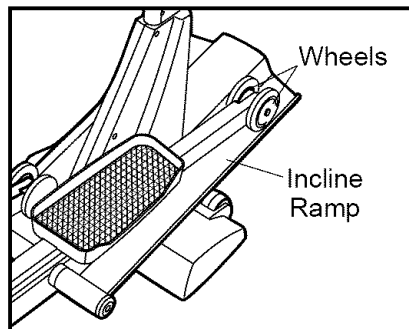

HOW TO LEVEL THE ELLIPTICAL EXERCISER

If the elliptical exerciser rocks during use, turn one or both of the leveling feet under the rear stabilizer until the rocking motion is eliminated.

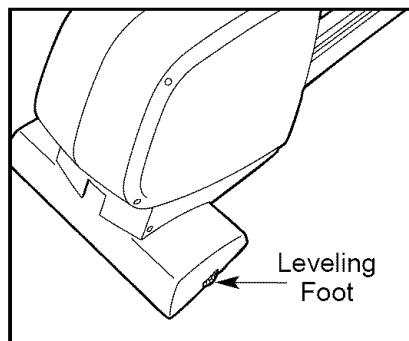

HOW TO CALIBRATE THE INCLINE SYSTEM

If the elliptical exerciser's incline system is not working properly, activate the calibration process by following the steps below.

1. Hold down the + button and the Program Select button at the same time for about five seconds. Note: Numbers may appear in the left and right displays. Disregard these numbers.
2. Press the Program Select button again. Note: A combination of letters and numbers may appear in the displays.
3. Press the 30° Ramp button. The ramp will move all of the way up and then all of the way down.
4. Press the Program Select button three times. The console will then be in the normal operating mode and the elliptical exerciser will be ready for use.

CONDITIONING GUIDELINES

WARNING:



Before beginning this or any exercise program, consult your physician. This is especially important for persons over the age of 35 or persons with pre-existing health problems.

The pulse sensor is not a medical device. Various factors may affect the accuracy of heart rate readings. The pulse sensor is intended only as an exercise aid in determining heart rate trends in general.

The following guidelines will help you to plan your exercise program. Remember that proper nutrition and adequate rest are essential for successful results.

EXERCISE INTENSITY

Whether your goal is to burn fat or to strengthen your cardiovascular system, the key to achieving the desired results is to exercise with the proper intensity. The proper intensity level can be found by using your heart rate as a guide. The chart below shows recommended heart rates for fat burning, maximum fat burning, and cardiovascular (aerobic) exercise.

165	155	145	140	130	125	115	
145	138	130	125	118	110	103	
125	120	115	110	105	95	90	
20	30	40	50	60	70	80	

To find the proper heart rate for you, first find your age on the bottom line of the chart (ages are rounded off to the nearest ten years). Next, find the three numbers above your age. The three numbers are your “training zone.” The lower two numbers are recommended heart rates for fat burning; the highest number is the recommended heart rate for aerobic exercise.

Fat Burning

To burn fat effectively, you must exercise at a relatively low intensity level for a sustained period of time.

During the first few minutes of exercise, your body uses easily accessible *carbohydrate* calories for energy. Only after the first few minutes of exercise does your body begin to use stored *fat* calories for energy. If your goal is to burn fat, adjust the intensity of your exercise until your heart rate is near the lowest number in your training zone as you exercise.

For maximum fat burning, adjust the intensity of your exercise until your heart rate is near the middle number in your training zone as you exercise.

Aerobic Exercise

If your goal is to strengthen your cardiovascular system, your exercise must be “aerobic.” Aerobic exercise is activity that requires large amounts of oxygen for prolonged periods of time. This increases the demand on the heart to pump blood to the muscles, and on the lungs to oxygenate the blood. For aerobic exercise, adjust the intensity of your exercise until your heart rate is near the highest number in your training zone as you exercise.

WORKOUT GUIDELINES

Each workout should include the following three parts:

A warm-up, consisting of 5 to 10 minutes of stretching and light exercise. A proper warm-up increases your body temperature, heart rate, and circulation in preparation for exercise.

Training zone exercise, consisting of 20 to 30 minutes of exercising with your heart rate in your training zone. (During the first few weeks of your exercise program, do not keep your heart rate in your training zone for longer than 20 minutes.)

A cool-down, with 5 to 10 minutes of stretching. This will increase the flexibility of your muscles and will help to prevent post-exercise problems.

EXERCISE FREQUENCY

To maintain or improve your condition, complete three workouts each week, with at least one day of rest between workouts. After a few months of regular exercise, you may complete up to five workouts each week if desired. The key to success is to make exercise a regular and enjoyable part of your everyday life.

PART LIST—Model No. NTE11920

R0103A

Key No.	Qty.	Description	Key No.	Qty.	Description
1	1	Frame	54	1	Clamp
2	1	Upright	55	1	Reed Switch/Wire
3	1	Ramp	56	1	Return Spring
4	1	Left Pedal Leg	57	1	Guide Rod
5	1	Right Pedal Leg	58	1	Resistance Cable
6	1	Rear Stabilizer	59	1	Flywheel Axle
7	1	Rear Stabilizer Cover	60	2	Flywheel Bearing
8	1	Front Stabilizer	61	2	Eye Bolt
9	1	Front Stabilizer Cover	62	2	Adjustment Bracket
10	1	Left Pedal	63	2	M8 x 47mm Button Bolt
11	1	Right Pedal	64	2	M6 Washer
12	1	Incline Motor	65	2	M10 x 78mm Bolt Set
13	1	Incline Axle	66	2	M8 Washer
14	1	Pivot Axle	67	2	M10 x 50mm Bolt Set
15	1	Left Side Shield	68	2	Handlebar Bushing
16	1	Right Side Shield	69	10	M4 x 16mm Tek Screw
17	1	Console	70	2	M10 x 110mm Button Screw
18	1	Right Flywheel Cover	71	1	M8 Tek Washer
19	1	Left Flywheel Cover	72	1	M11 x 40mm Bolt Set
20	2	Pulse Sensor w/Wire	73	2	M10 Split Washer
21	1	Right Incline Cover	74	1	M8 x 25mm Button Bolt
22	1	Left Incline Cover	75	1	M10 x 19mm Button Bolt
23	1	Right Handlebar	76	8	M6 x 16mm Patch Screw
24	1	Left Handlebar	77	4	M5 Nut
25	1	Upper Handlebar Cover	78	4	M5 x 16mm Bolt
26	2	Handlebar Cover	79	4	M5 Washer
27	1	Frame Cover	80	2	M6 x 18mm Bolt
28	4	Pedal Wheel	81	1	M6 x 25mm Bolt
29	8	Wheel Bearing	82	2	5/16" x 25mm Flange Screw
30	2	Wheel Frame	83	4	M8 x 58mm Button Screw
31	2	Wheel Spacer	84	8	M8 x 44mm Button Screw
32	1	"C" Magnet	85	4	M8 x 41mm Button Bolt
33	1	Magnet Bracket	86	6	M8 Jam Nut
34	1	Left Crank Arm	87	8	M4 x 38mm Screw
35	2	28.7mm Pulley Spacer	88	3	M8 Nylon Locknut
36	1	Flywheel	89	1	M10 Nylon Locknut
37	1	Magnet	90	3	M6 Nut
38	1	Pulley	91	2	M6 Nylon Locknut
39	1	Control Box Cover	92	2	Snap Ring
40	1	Control Board	93	2	M8 x 54mm Button Screw
41	1	Control Box	94	3	M4 x 10mm Screw
42	1	Lower Wire Harness	95	6	M4 x 19mm Screw
43	1	Crank	96	1	M4 x 12mm Screw
44	2	Crank Bearing	97	2	M4 x 25mm Screw
45	1	Idler	98	15	M4 x 16mm Screw
46	4	Foot	99	2	Ramp Spacer
47	4	Ramp Bushing	100	4	M5 Nylon Locknut
48	2	Ramp Cover	101	2	31.5mm Pulley Spacer
49	1	Incline Sensor	102	1	Right Crank Arm
50	1	Sensor Cover	103	1	Flywheel Spacer
51	4	Pedal Leg Bushing	104	2	Support Plate
52	1	Resistance Motor	105	2	M8 x 38mm Button Bolt
53	1	Reed Switch Bracket	106	2	Upper Foam Grip

Key No.	Qty.	Description	Key No.	Qty.	Description
107	2	Lower Foam Grip	114	1	Pulse Extension Wire
108	3	M4 x 25mm Tek Screw	115	1	Upper Wire Harness
109	2	Spacer	116	1	Power Cord
110	6	Wheel Bushing	117	1	Power Socket
111	2	M8 x 19mm Patch Screw	#	4	Allen Wrench
112	2	Wheel	#	1	User's Manual
113	1	Belt			

Note: # indicates a non-illustrated part. Specifications are subject to change without notice. See the back cover of this manual for information about ordering replacement parts.

EXPLODED DRAWING—Model No. NTE11920

R0103A

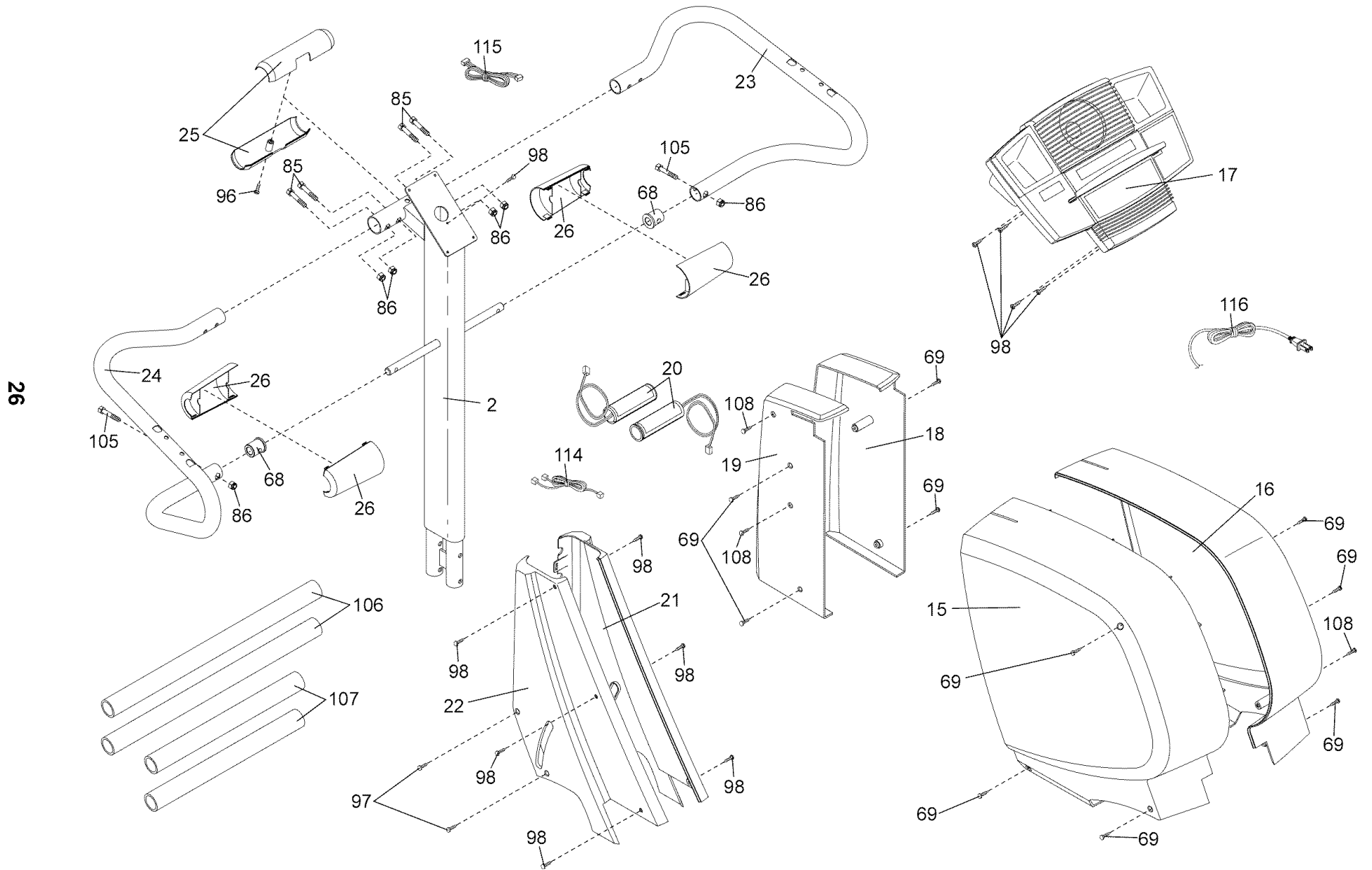

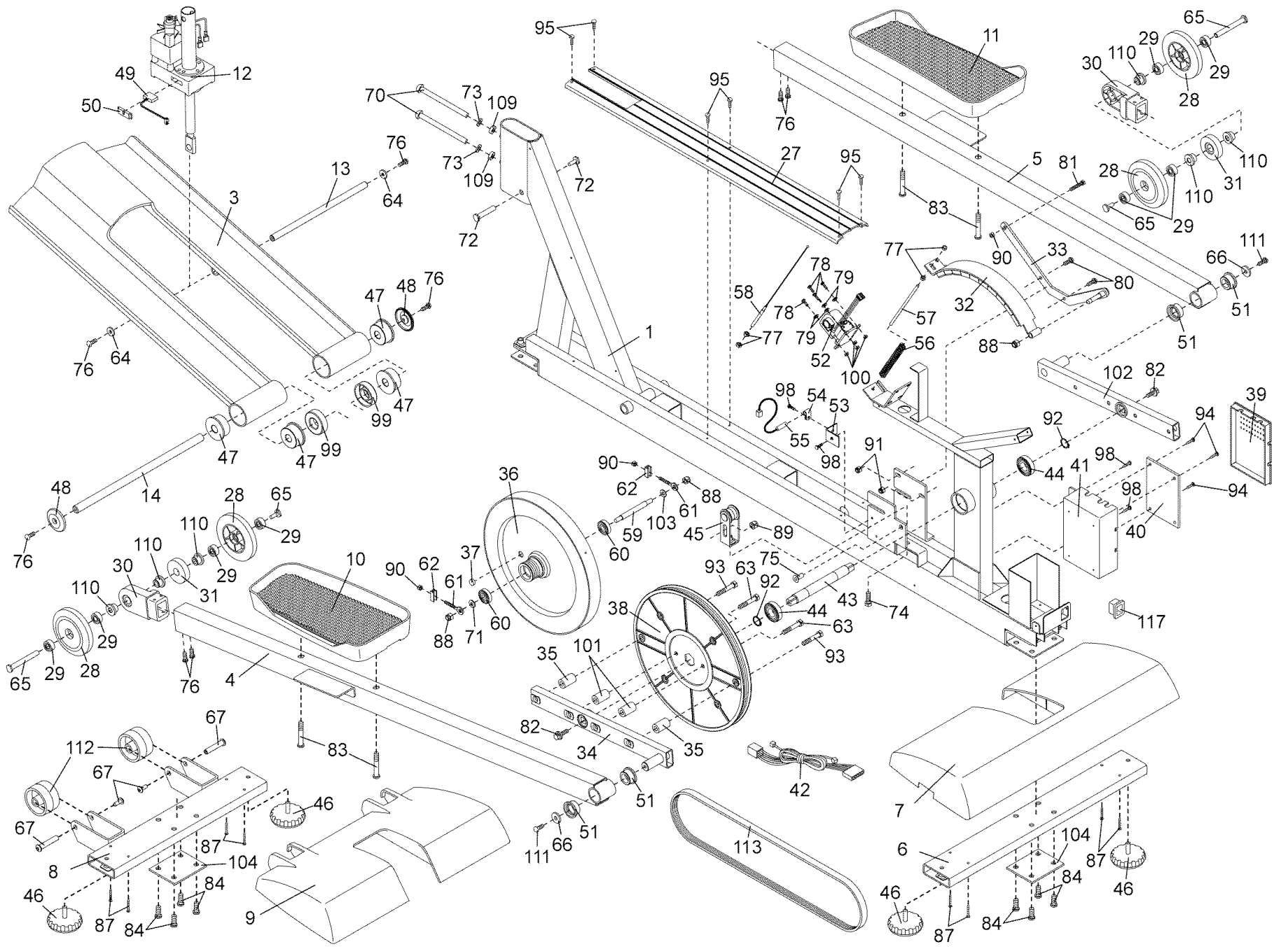

HOW TO ORDER REPLACEMENT PARTS

To order replacement parts, simply call our Customer Service Department toll-free at 1-888-825-2588, Monday through Friday, 6 a.m. until 6 p.m. Mountain Time (excluding holidays). To help us assist you, please be prepared to give the following information when calling:

- The MODEL NUMBER of the product (NTE11920)
- The NAME of the product (NordicTrack® CX 985 elliptical exerciser)
- The SERIAL NUMBER of the product (see the front cover of this manual)
- The KEY NUMBER and DESCRIPTION of the part(s) (see pages 24 and 25)

LIMITED WARRANTY

WHAT IS COVERED—The entire NordicTrack® elliptical exerciser (“Product”) is warranted to be free of all defects in material and workmanship.

WHO IS COVERED—The original purchaser or any person receiving the Product as a gift from the original purchaser.

HOW LONG IS IT COVERED—ICON Health & Fitness, Inc. (“ICON”), warrants the product for one year after the date of purchase. Labor is covered for one year.

WHAT WE DO TO CORRECT COVERED DEFECTS—We will ship to you, without charge, any replacement part or component, providing the repairs are authorized by ICON first and are performed by an ICON trained and authorized service provider, or, at our option, we will replace the Product.

WHAT IS NOT COVERED—Any failures or damage caused by unauthorized service, misuse, accident, negligence, improper assembly or installation, alterations, modifications without our written authorization or by failure on your part to use, operate, and maintain as set out in your User’s Manual (“Manual”).

WHAT YOU MUST DO—Always retain proof of purchase, such as your bill of sale; store, operate, and maintain the Product as specified in the Manual; notify our Customer Service Department of any defect within 10 days after discovery of the defect; as instructed, return any defected part for replacement or, if necessary, the entire product, for repair.

USER’S MANUAL—It is VERY IMPORTANT THAT YOU READ THE MANUAL before operating the Product. Remember to do the periodic maintenance requirements specified in the Manual to assure proper operation and your continued satisfaction.

HOW TO GET PARTS AND SERVICE—Simply call our Customer Service Department at 1-888-825-2588 and tell them your name and address and the serial number of your Product. They will tell you how to get a part replaced, or if necessary, arrange for service where your Product is located or advise you how to ship the Product for service. Before shipping, always obtain a Return Authorization Number (RA No.) from our Customer Service Department; securely pack your Product (save the original shipping carton if possible); put the RA No. on the outside of the carton and insure the product. Include a letter explaining the product or problem and a copy of your proof of purchase if you believe the service is covered by warranty.

ICON is not responsible or liable for indirect, special or consequential damages arising out of or in connection with the use or performance of the product or damages with respect to any economic loss, loss of property, loss of revenues or profits, loss of enjoyment or use, costs of removal, installation or other consequential damages of whatsoever nature. Some states do not allow the exclusion or limitation of incidental or consequential damages. Accordingly, the above limitation may not apply to you.

The warranty extended hereunder is in lieu of any and all other warranties and any implied warranties of merchantability or fitness for a particular purpose is limited in its scope and duration to the terms set forth herein. Some states do not allow limitations on how long an implied warranty lasts. Accordingly, the above limitation may not apply to you.

No one is authorized to change, modify or extend the terms of this limited warranty. This warranty gives you specific legal rights and you may have other rights which vary from state to state.

ICON HEALTH & FITNESS, INC., 1500 S. 1000 W., LOGAN, UT 84321-9813