



# USB 2.0 Ranger<sup>®</sup> 2304-LAN

4-Port USB 2.0 Ethernet LAN Extender System

## User Guide



Thank you for purchasing the USB 2.0 Ranger® 2304-LAN.

Please read this guide thoroughly.

This document applies to Part Numbers: 00-00335, 00-00336, 00-00337, and 00-00338.

### **FCC Radio Frequency Interference Statement Warning**

This device complies with Part 15 of the FCC rules. Operation is subject to the following two conditions: (1) this device may not cause harmful interference, and (2) this device must accept any interference received including interference that may cause undesired operation.

### **CE Statement**

We, Icron Technologies Corporation, declare under our sole responsibility that the Ranger 2304-LAN, to which this declaration relates, is in conformity with European Standard EN 55022, EN 55024, EN 61000-3-2, and EN 61000-3-3.

### **IC Statement**

This Class B digital apparatus complies with Canadian ICES-003.

©2013 Icron Technologies Corporation. All rights reserved. Icron Technologies Corporation, the Icron Technologies Corporation logo, and the Icron Technologies Corporation products referred to herein are either the trademarks or the registered trademarks of Icron Technologies Corporation. All other trademarks are property of their respective owners. Icron Technologies Corporation assumes no responsibility for errors that may appear in this manual. Information contained herein is subject to change without notice.  
Document #90-01055-A03

# Contents

<b>Introduction</b> .....	<b>3</b>
Ranger 2304-LAN Product Contents .....	3
Features .....	3
The LEX Unit .....	4
The REX Unit.....	5
<b>Installation Guide</b> .....	<b>6</b>
Installing the Ranger 2304-LAN System on a Local Area Network.....	6
Requirements .....	6
Preparing your Network .....	6
Preparing Your Site .....	7
Installing the LEX Unit .....	7
Installing the REX Unit .....	7
Installing the Ranger 2304-LAN System as Direct Connect .....	8
Requirements .....	8
Preparing Your Site .....	8
Installing the LEX Unit .....	9
Connecting the LEX Unit to the REX Unit .....	9
Installing the REX Unit .....	9
Checking the Installation .....	10
Connecting a USB Device.....	11
Pairing the LEX and REX.....	11
Unpairing a Unit .....	11
Compatibility .....	11
<b>Troubleshooting</b> .....	<b>12</b>
<b>Contacting Technical Support</b> .....	<b>14</b>
<b>Warranty Information</b> .....	<b>14</b>
<b>Obtaining Warranty Service</b> .....	<b>15</b>
<b>Contacting Sales</b> .....	<b>15</b>
<b>Contacting Technical Support</b> .....	<b>15</b>
<b>Technical Glossary</b> .....	<b>16</b>
<b>Specifications</b> .....	<b>17</b>

## Introduction

This guide provides product information for the Ranger 2304-LAN, installation instructions, troubleshooting guidelines, and instructions for contacting Icron regarding technical support and warranty information.

The instructions in this guide assume a general knowledge of computer installation procedures, familiarity with cabling requirements, and some understanding of USB devices.

 NOTE: Notes provide additional information that could be useful.

 CAUTION: Cautions provide important information about an operational requirement.

## Ranger 2304-LAN Product Contents

Your Ranger 2304-LAN is packaged with:

- LEX Unit (Local Extender)
- REX Unit (Remote Extender)
- USB 2.0 Cable
- REX AC International Power Adapter
- Country Specific Power Cable
- Quick Start Guide and Warranty Information

## Features

The Ranger 2304-LAN incorporates Icron's patented ExtremeUSB® technology, enabling users to extend USB beyond the standard 5m cable limit for USB 2.0 peripheral devices. The Ranger 2304-LAN has the following key features:

- 100m of extension when directly connected over Cat 5e
- USB extension over a Local Area Network (LAN)
- Support for new USB 3.0 host controllers and devices over previous Ranger products
- Support for bulk and HID type devices (storage and mouse/keyboard types)

 USB 3.0 devices will perform at USB 2.0 speeds if extended through the Ranger 2304-LAN.

 The Ranger 2304-LAN does not support isochronous devices. Examples of isochronous devices are most webcams, audio devices, and some "composite" devices that combine functionality, such as enhanced keyboards that handle audio.

The Ranger 2304-LAN extender system is composed of two individual units: the LEX unit and the REX unit.

 All references to Cat 5e cable in this document represent the minimum requirement. Category 6 or better and/or STP cable may be substituted.

## The LEX Unit

The Local Extender (LEX) unit connects to the computer using a standard USB 2.0 cable. Power for this unit is provided by the the host computer.

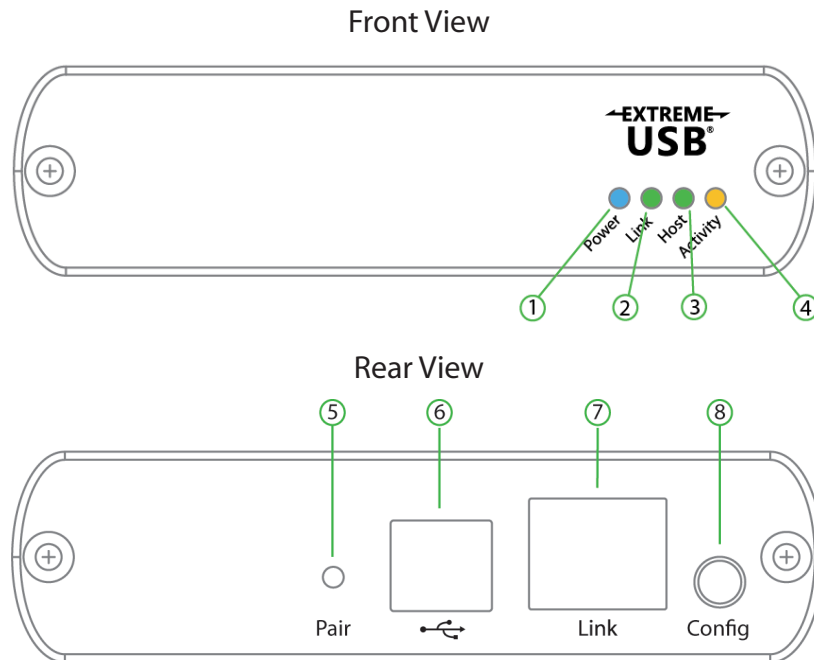

ITEM	TYPE	DESCRIPTION
1	Power LED (Blue)	LED turns on when power is supplied, off when no power is supplied by the Host computer.
2	Link LED (Green)	Indicates a valid ExtremeUSB link is established between the LEX and REX units. The LED turns on when link between LEX and REX is established and off when there is no link between LEX and REX. Fast blinking indicates the unit is in Pairing mode, slow blinking indicates the unit is attempting to establish a link.
3	Host LED (Green)	Indicates that the Ranger 2304-LAN system is properly enumerated on the host computer. The LED blinks when the Ranger 2304-LAN is in a suspended state.
4	Activity LED (Amber)	Indicates data transmission is occurring between LEX and REX. LED blinks intermittently with or without a USB device connected. When the LEX and REX are in suspend mode, the LED is off.
5	Pair	Used to establish a paired connection between LEX and REX.
6	USB Host Port	Used to connect the LEX unit to the host computer. Accepts Type B connector into the LEX unit.
7	Link Port (RJ45)	Accepts RJ45 connector for Cat 5e cabling (or better) to connect the LEX unit to the REX unit.
8	Config	Reserved for manufacturer use.

## The REX Unit

The Remote Extender (REX) unit provides USB Type A ports for standard USB devices. The REX unit allows you to connect up to four USB devices directly. Additional devices may be connected by attaching USB hubs to the REX unit. The REX unit is powered by an external AC adapter and can supply up to 500mA to each USB port.

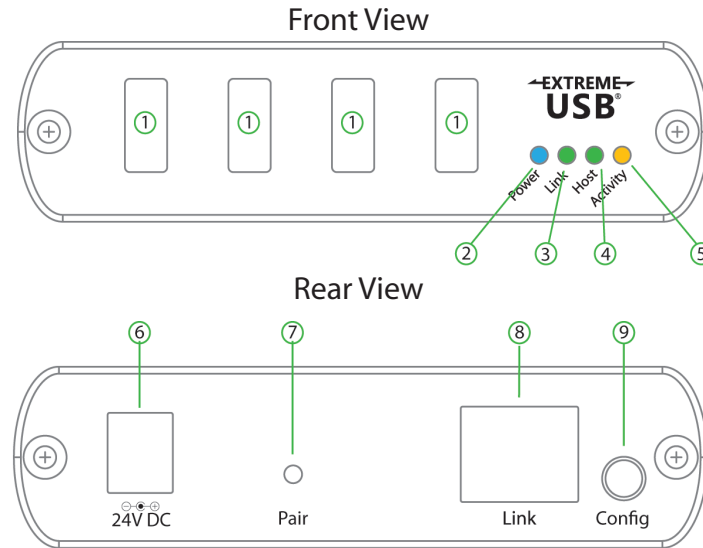

ITEM	TYPE	DESCRIPTION
1	USB Device Ports	Accepts USB device(s) using Type A connectors.
2	Power LED (Blue)	LED turns on when power is supplied, off when no power is supplied.
3	Link LED (Green)	Indicates a valid ExtremeUSB link is established between the LEX and REX units. The LED turns on when link between LEX and REX is established and off when there is no link between LEX and REX. Fast blinking indicates the unit is in Pairing mode, slow blinking indicates the unit is attempting to establish a link.
4	Host LED (Green)	Indicates that the Ranger 2304-LAN system is properly enumerated on the host computer. The LED blinks when the Ranger 2304-LAN is in a suspended state.
5	Activity LED (Amber)	Indicates data transmission is occurring between LEX and REX. LED blinks intermittently with or without a USB device connected. When the LEX and REX are in suspend mode, the LED is off.
6	Power Port	Connects to the AC power supply. Required at REX for proper operation.
7	Pair	Used to establish a paired connection between LEX and REX.
8	Link Port (RJ45)	Accepts RJ45 connector for Cat 5e cabling (or better) to connect the LEX unit to the REX unit.
9	Config	Reserved for manufacturer use.

# Installation Guide

## Installing the Ranger 2304-LAN System on a Local Area Network

### Requirements

To complete the installation, you will also require the following items that are not included with the product:

- USB compatible computer (host computer) with a USB compliant operating system
- USB compatible device(s)
- Two Cat 5e patch cables
- Preconfigured Local Area Network

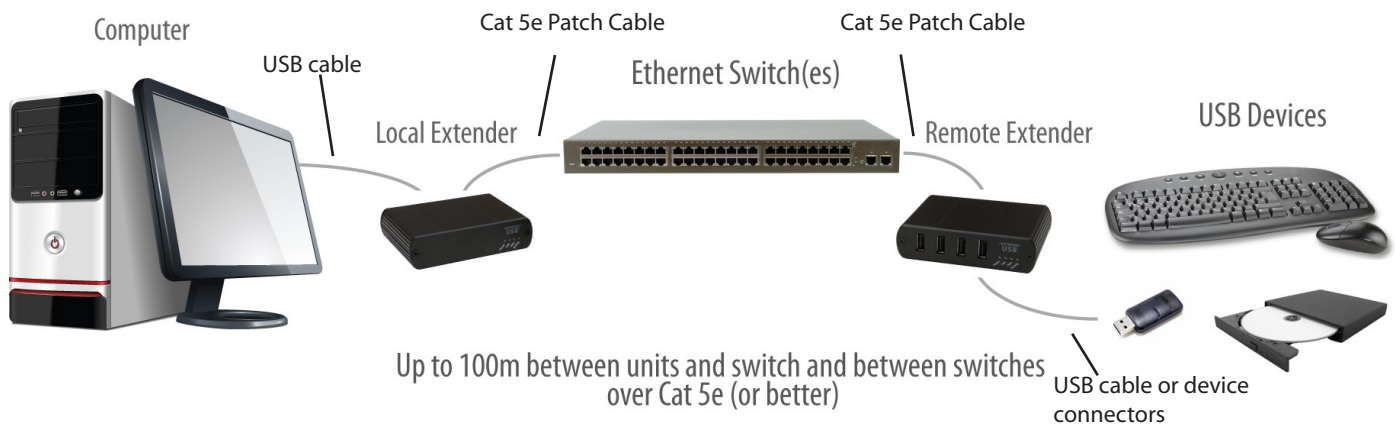

### Preparing your Network

Your network must be properly configured in order for full USB 2.0 throughput to be realized and for maximum stability and reliability of your devices. Consult with your network administrator prior to installation. Using the Ranger 2304-LAN over a network requires:

- LEX and REX units to be on the same subnet
- RJ45 information outlets to be near the computer and USB devices to be connected to the network switch(es)
- Pre-installed and configured Local Area Network

! USB 2.0 is capable of consuming up to 480Mbps. For that reason, Icron Technologies highly recommends using the Ranger 2304-LAN on Gigabit networks (1000Base-T) and not 100 Megabit networks (100Base-T). The performance of the USB network extension will be limited to the slowest link between the LEX and the REX.

! Some networks may be configured to block devices with unfamiliar MAC addresses. If this is the case, you will need to provide your network administrator the MAC addresses of the LEX and REX units. These can be found on the label on the bottom of each unit.

! Some networks may be configured to block devices that consume a consistently high level of bandwidth. The Ranger 2304-LAN may exhibit this behaviour when high bandwidth devices are connected. Consult with your network administrator to resolve this.

**note** Units will be pre-paired with each other if they were sold together in the same box. If they are not paired, follow the instructions provided in the section for pairing a LEX and REX.

**note** Increasing the number of switches between the LEX and REX may reduce the available bandwidth and as a result prevent some devices from functioning properly.

## Preparing Your Site

Before you can install the Ranger 2304-LAN, you need to prepare your site:

1. Place the computer where desired and set it up.
2. Ensure that where you want to locate the USB device(s) is within 100m of Cat 5e cabling of the switch.
3. Ensure that where you want to locate the computer is within 100m of Cat 5e cabling of the switch.



The cable distance between switches must be no greater than 100m if Cat 5e is used as the connection media.

## Installing the LEX Unit

1. Place the LEX unit near the computer.
2. Connect the supplied USB cable between the LEX host port and a USB port on the host computer.
3. Connect a Cat 5e patch cable (not provided) into the information outlet near the host computer.
4. Connect the patch cable into the Link port of the LEX unit.

## Installing the REX Unit

1. Connect a Cat 5e patch cable (not provided) into the information outlet near the USB devices.
2. Connect the patch cable into the Link port of the REX unit.
3. Place the REX unit near the USB device(s).
4. Assemble the power adapter and country specific power cord together and connect them into a suitable AC outlet.
5. Connect the power adapter to the REX unit.



# Installing the Ranger 2304-LAN System as Direct Connect

## Requirements

To complete the installation, you will also require the following items that are not included with the product:

- USB compatible computer (host computer) with a USB compliant operating system
- USB compatible device(s)
- Cat 5e Unshielded Twisted Pair (UTP) cable with two RJ45 connectors (if using surface cabling), OR, Cat 5e cabling with two information outlets and two Cat 5e patch cords with RJ45 connectors (if using premise cabling)

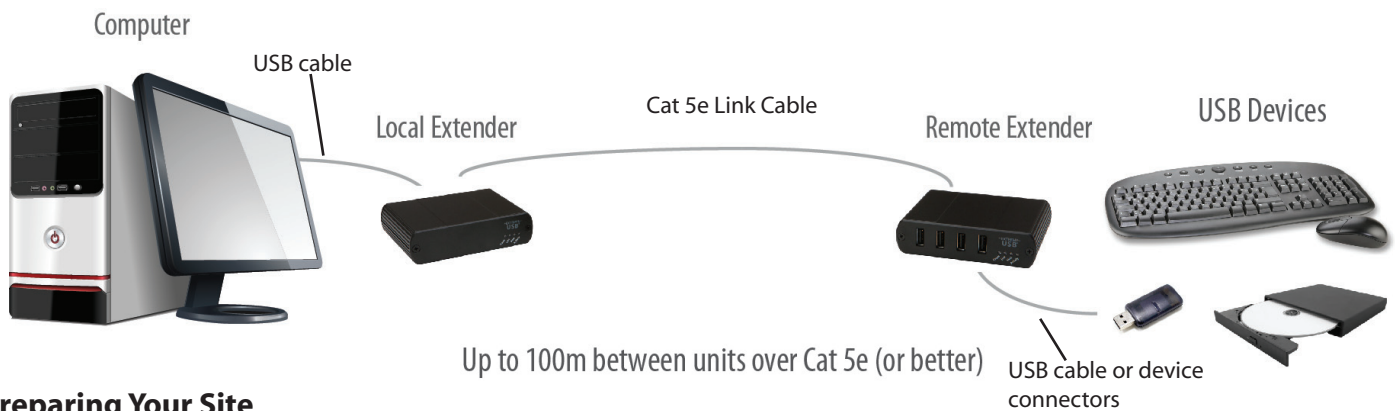

## Preparing Your Site

Before you can install the Ranger 2304-LAN, you need to prepare your site:

1. Place the computer where desired and set it up.
2. Ensure that where you want to locate the USB device(s) is within 100m (cable-length) of the computer. If not, adjust the location of the devices and/or computer accordingly.
3. If you are using surface cabling, install the Cat 5e cabling as desired and terminate it with the appropriate RJ45 ends.

If you are using premise cabling, ensure Cat 5e cabling is installed between the two locations and if necessary patched together. Cat 5e information outlets should be located near the computer and the USB device(s), and the total length, including patch cords must be less than 100m.

- ! Cable installation is important, particularly if high throughput applications are used. When installing, ensure the cable is installed away from or isolated from potential sources of interference such as electrical wiring, fluorescent lighting, etc.



When terminating cables, ensure the matching RJ45 connector is used for the cable type. For example, if Cat 6 cable is used, then Cat 6 compatible RJ45 connectors must be used. If this care is not taken, the benefits of higher grade cabling may not be realized.

## **Installing the LEX Unit**

1. Place the LEX unit near the computer.
2. Connect the supplied USB cable between the LEX host port and a USB port on the host computer.

## **Connecting the LEX Unit to the REX Unit**

### With Surface Cabling

1. Connect the cable into the Link port of the LEX unit.
2. Connect the cable into the Link port of the REX unit.

### With Premise Cabling

1. Connect a Cat 5e patch cable (not provided) into the information outlet near the host computer.
2. Connect the patch cable into the Link port of the LEX unit.
3. Connect a Cat 5e patch cable (not provided) into the information outlet near the USB devices.
4. Connect the patch cable into the Link port of the REX unit.

## **Installing the REX Unit**

1. Place the REX unit near the USB device(s).
2. Assemble the power adapter and country specific power cord together and connect them into a suitable AC outlet.
3. Connect the power adapter to the REX unit.

## Checking the Installation

1. On the LEX and REX units, check that the Power, Status, Link and Host LEDs are on.
  - For direct connect, if the Host or Link LEDs are permanently off, then the cabling between the LEX and REX units may not be installed properly or is defective.
  - For network connect, if the Link LED is blinking, then the network connection between the LEX and REX is not complete and there may be faulty cabling, network components, misconfigured network components, or the LEX and REX units may need to be re-paired together (see the section on pairing a LEX and REX).
2. For Windows users (XP, 7, 8), open Device Manager to confirm that the Ranger 2304-LAN has installed correctly. Expand the entry for Universal Serial Bus controllers by clicking the “+” sign. If the Ranger 2304-LAN has been installed correctly, you should find it listed as a “Generic USB Hub”.



To open Device Manager in Windows XP:

Right click “My Computer” then select: Properties >> Hardware tab >> Device Manager



To open Device Manager in Windows 7 or 8

Open the Start menu, right click on “Computer” then select: Manage >> Device Manager

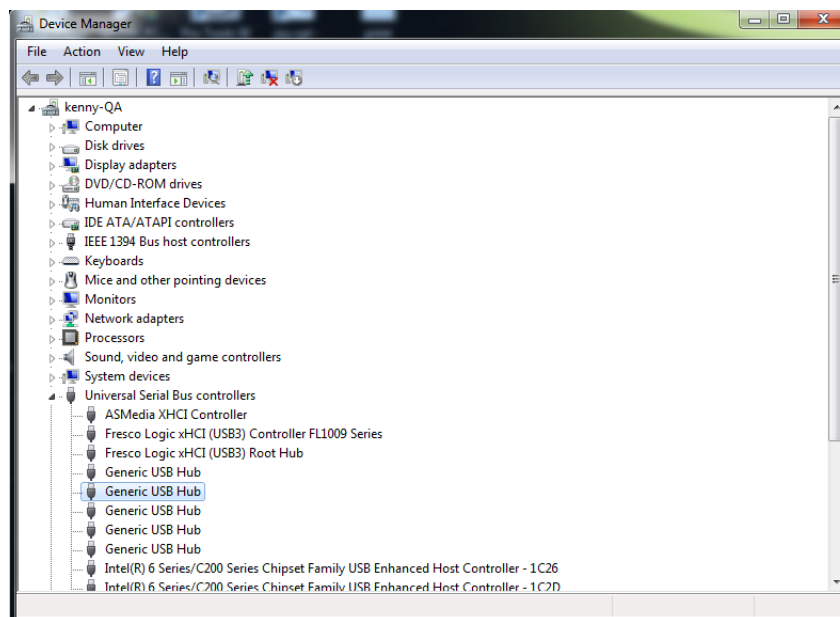

3. For Mac OS X users, open the System Profiler to confirm that the Ranger 2304-LAN has installed correctly. In the left hand column under Hardware, select “USB” and inspect the right hand panel. If the Ranger 2304 has been installed correctly, you should find it listed as a “Hub” under the USB High-Speed Bus/USB Bus.



To open System Profiler in OS X: Open the Finder, select Applications, then open the Utilities folder and double click on the System Profiler icon.

4. If the Ranger 2304-LAN is not detected correctly or fails to detect, please consult the Troubleshooting Section later in this guide.

## Connecting a USB Device

1. Install any software required to operate the USB device(s). Refer to the documentation for the USB device(s), as required.
2. Connect the USB device to the device port on the REX unit.
3. Check that the device is detected and installed properly in the operating system.

## Pairing the LEX and REX

When bought as a complete system, that consists of both a LEX and a REX, the units will be paired with each other out of the box, so no pairing action should be required. However, if units are bought individually, individual units have been placed, or you simply wish to change the LEX and REX pairings across a network, then the following steps must be taken:

 The following steps apply to both direct connect and network connect configurations for the Ranger 2304-LAN.

1. Ensure the LEX and REX units are either directly connected to each other, or are connected to the same subnet on your network.
2. Press and hold the Pairing button on the back of the LEX. Release the button within 10 seconds. The Link LED will start flashing.
3. Within 10 minutes of activating the pairing mode on the LEX, press and hold the Pairing button on the back of the REX. Release the button within 10 seconds. The Link LED will start flashing.
4. The Link LED on both units may start flashing more slowly before finally turning on. Once the Link LEDs are solid, the link is established between both units.

 If more than 10 minutes passes before the units are paired, then the units will switch back to regular mode and reestablish the previous links they had, if any.

 To cancel pairing mode, press and hold the Pairing button a second time. Release it within 10 seconds.

## Unpairing a Unit

If for any reason a unit needs to have its pairing removed, this can be done by pressing and holding the Pair button for longer than 10 seconds. Once this is completed the unit will not be paired to any other unit.

## Compatibility

The USB 2.0 Ranger 2304-LAN complies with USB 1.1 and USB 2.0 specifications governing the design of USB devices. However, Icron Technologies Corporation does not guarantee that all USB devices or hosts will be compatible with the Ranger 2304-LAN, as there are a number of different characteristics that may impact the operation of USB devices over extended distances.

 The USB 2.0 Ranger 2304-LAN does not support isochronous devices. These are typically audio or video based devices. It is strongly recommended to not plug these devices into the extender system.

## Troubleshooting

The following table provides troubleshooting tips. The topics are arranged in the order in which they should be executed in most situations. If you are unable to resolve the problem after following these instructions, please contact Technical Support for further assistance.

<b>PROBLEM</b>	<b>CAUSE</b>	<b>SOLUTION</b>
All LEDs on LEX unit are off.	<ul style="list-style-type: none"> <li>The LEX unit is not receiving power from the USB port.</li> </ul>	<ol style="list-style-type: none"> <li>Ensure that the host computer is connected to the LEX.</li> <li>Move the USB connector to another USB port on the host computer.</li> </ol>
All LEDs on REX unit are off.	<ul style="list-style-type: none"> <li>The REX unit is not receiving power from the AC adapter.</li> </ul>	<ol style="list-style-type: none"> <li>Ensure that the AC power adapter is properly connected to the REX unit.</li> <li>Check that the AC adapter is connected to a live source of electrical power. Check that the REX power LED is illuminated.</li> </ol>
Link LEDs on LEX unit and REX unit are off.	<ul style="list-style-type: none"> <li>There is no connection between the LEX unit and REX unit.</li> </ul>	<ol style="list-style-type: none"> <li>Ensure Cat 5e cable is connected between the LEX unit and REX unit. Cat 5e or better cable, UTP with a straight through connector and no crossovers, and 8 conductor RJ45 connectors are used at both ends.</li> <li>Connect a short Cat 5e patch cord between the LEX unit and REX unit to determine if the original Cat 5e cable is defective.</li> </ol>
Link LEDs are blinking.	<ul style="list-style-type: none"> <li>There is no connection between the LEX unit and REX unit.</li> <li>Units may not be paired to each other</li> <li>Network switches exist on different subnets.</li> <li>Network switch(es) are blocking traffic from the extenders.</li> </ul>	<ol style="list-style-type: none"> <li>Ensure both the LEX and REX units are connected together directly or are connected to active network switches.</li> <li>Re-pair the units together.</li> <li>Ensure the network switches can communicate with each other and are on the same subnet.</li> <li>Ensure the network switches are not blocking traffic from the extenders either based on MAC address or due to traffic patterns.</li> <li>Consult with your network administrator.</li> </ol>

<b>PROBLEM</b>	<b>CAUSE</b>	<b>SOLUTION</b>
Link LED on LEX and REX units are blinking slowly.	<ul style="list-style-type: none"> <li>• The units are paired with each other but have not yet established a link.</li> </ul>	<ol style="list-style-type: none"> <li>1. Wait for a few minutes for the LEDs to go solid.</li> <li>2. If LEDs do not go solid, contact your network administrator to determine if any traffic is being blocked between the units.</li> </ol>
Link LED on LEX unit is on, Host LED on LEX unit is off.	<ul style="list-style-type: none"> <li>• The host computer is not powered on.</li> <li>• The LEX unit is not connected to the computer .</li> <li>• The host computer is not recognizing the LEX.</li> <li>• The computer does not support USB hubs.</li> <li>• The Ranger 2304-LAN is malfunctioning.</li> </ul>	<ol style="list-style-type: none"> <li>1. Disconnect all USB devices from the REX unit.</li> <li>2. Disconnect the LEX unit from the computer.</li> <li>3. Disconnect the REX unit from the AC power adapter.</li> <li>4. Reconnect the LEX unit to the computer.</li> <li>5. Reconnect the REX unit to the AC power adapter.</li> <li>6. In the Universal Serial Bus controllers section of Device Manager, check that the Ranger 2304-LAN is recognized as a "Generic USB Hub".</li> </ol>
My USB device does not work properly.	<ul style="list-style-type: none"> <li>• Insufficient bandwidth is available on the network to support the device.</li> <li>• The device is an isochronous type device (webcam, audio device, etc).</li> </ul>	<ol style="list-style-type: none"> <li>1. Connect the LEX and REX directly to each other and try the USB device again.</li> <li>2. Isochronous devices are not supported by the Ranger 2304-LAN</li> </ol>
My USB device does not work at all.	<ul style="list-style-type: none"> <li>• Insufficient bandwidth is available on the network to support the device.</li> <li>• The LEX is not paired to the wrong REX.</li> <li>• The device is an isochronous type device (webcam, audio device, etc).</li> </ul>	<ol style="list-style-type: none"> <li>1. Connect the LEX and REX directly to each other and try the USB device again.</li> <li>2. Follow the instructions on page 11 and pair the LEX to the REX that is connected to the device you wish to use.</li> <li>3. Isochronous devices are not supported by the Ranger 2304-LAN</li> </ol>

## Contacting Technical Support

If you are experiencing problems not referenced in the Troubleshooting section, you may contact **Icron Technical Support** at [icron.com/support](https://icron.com/support).

## Warranty Information

### Limited Hardware Warranty

Icron Technologies Corporation warrants that any hardware products accompanying this documentation shall be free from significant defects in material and workmanship for a period of **two years from the date of purchase**. Icron Technologies Corporation's hardware warranty extends to Licensee, its customers, and end users.

The Warranty does not include repair of failures caused by: misuse, neglect, accident, modification, operation outside a normal operating environment, failure caused by service of the device by non-authorized servicers, or failure caused by a product for which Icron Technologies Corporation is not responsible.

### Hardware Remedies

Icron Technologies Corporation's entire liability and the Licensee's exclusive remedy for any breach of warranty, shall be, at Icron Technologies Corporation's option, either (a) return of the price paid or (b) repair or replacement of hardware, which will be warranted for the remainder of the original warranty period or 30 days, whichever is longer. These remedies are void if failure of the hardware has resulted from accident, abuse, or misapplication.

### Limitation of Liability

The hardware warranty set forth in this agreement replaces all other warranties. Icron Technologies Corporation expressly disclaims all other merchantability and fitness for a particular purpose and noninfringement of third-party rights with respect to the hardware.

Icron Technologies Corporation dealer, agent, or employee is authorized to make any modification extension, or addition to this warranty. Under no circumstances will Icron Technologies Corporation, its suppliers or licensors be liable for any costs of procurement or substitute products or services, lost profits, loss of information or data, or any other special, indirect, consequential, or incidental damages arising in any way out of the sale of, use of, or inability to use Icron Technologies Corporation product or service, even if Icron Technologies Corporation, its suppliers or licensors have been advised of the possibility of such damages. In no case shall Icron Technologies Corporation, its suppliers and licensors' liability exceed the actual money paid for the products at issue.

Since some jurisdictions do not allow the limitation of implied warranties of liability for incidental, consequential, special or indirect damages, the above limitation may not always apply. The above limitation will not apply in case of personal injury where and to the extent that applicable law requires such liability.

## Obtaining Warranty Service

To obtain warranty service, you must first contact Icron Technologies Corporation within the warranty period for a Return Material Authorization (RMA) number. Icron Technologies Corporation will not accept returns without an authorized RMA number. Be sure you have the serial numbers of the local extender and remote extender before calling. Package the product appropriately for safe shipment and mark the RMA number on the outside of the package. The package must be sent prepaid to Icron Technologies Corporation. We recommend that you insure it or send it by a method that provides for tracking of the package. The repaired or replaced item will be shipped to you, at Icron Technologies Corporation's expense, not later than thirty days after Icron Technologies Corporation receives the defective product.

Address the returned product to:

RMA Coordinator  
Icron Technologies Corporation  
4664 Lougheed Highway, Suite 221  
Burnaby, BC Canada  
V5C 5T5

## Contacting Sales

Email: [sales@icron.com](mailto:sales@icron.com)  
Tel: +1 604 638 3920

## Contacting Technical Support

[icron.com/support](http://icron.com/support)  
Tel: +1 604 638 3920

To help us serve you better, please include the following information with your technical support request:

- Host computer make and model
- Type of Operating System installed (e.g. Windows XP, 7, 8, Mac OS X, etc)
- Part number and serial number for both the LEX and REX
- Make and model of any USB device(s) attached to the product
- Description of the installation
- Description of the problem
- Description of the network (i.e.: number of switches, switch model names, switch speeds, etc)



# Technical Glossary

## Category 5e (Cat 5e) Network Cabling

Category 5e cable is commonly also referred to as Cat 5e. This cabling is available in either solid or stranded twisted pair copper wire variants and as UTP (Unshielded Twisted Pair) or STP (Shielded Twisted Pair). UTP cables are not surrounded by any shielding making them more susceptible to electromagnetic interference (EMI). STP cables include shielding the copper wires and provides better protection against ElectroMagnetic Interference (EMI).

## USB 2.0 Cables

USB 2.0 cables have two distinct full-sized connectors. The Type A connector is used to connect the cable from a USB device to the Type A port on a computer or hub. The Type B connector is used to attach the USB cable to a USB device.

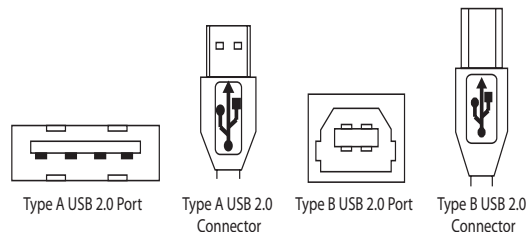

## RJ45

The Registered Jack (RJ) physical interface is what connects the network cabling (Cat 5e) to the LEX unit and REX unit. You may use either the T568A scheme (Table 1) or the T568B scheme (Table 2) for cable termination as the USB 2.0 Ranger 2304-LAN requires all four pairs of the cable. RJ45 connectors are sometimes also referred to as 8P8C connectors. Note that any given cable must be terminated using the same T568 scheme on both ends to operate correctly.

## RJ45 Pin Positioning

Table 1 - T568A Wiring

PIN	PAIR	WIRE	CABLE COLOR
1	3	1	WHITE/GREEN
2	3	2	GREEN
3	2	1	WHITE/ORANGE
4	1	2	BLUE
5	1	1	WHITE/BLUE
6	2	2	ORANGE
7	4	1	WHITE/BROWN
8	4	2	BROWN

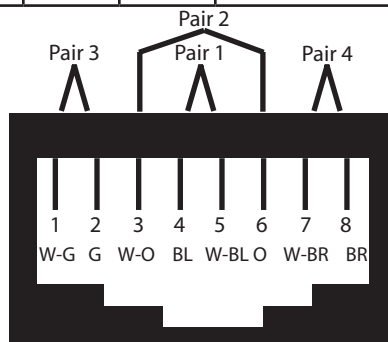
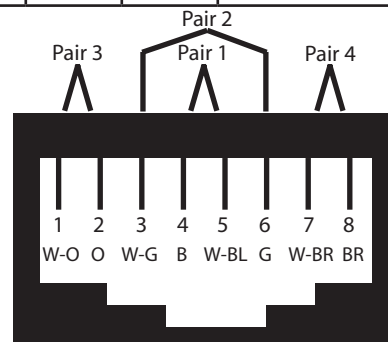

Table 2 - T568B Wiring

PIN	PAIR	WIRE	CABLE COLOR
1	2	1	WHITE/ORANGE
2	2	2	ORANGE
3	3	1	WHITE/GREEN
4	1	2	BLUE
5	1	1	WHITE/BLUE
6	3	2	GREEN
7	4	1	WHITE/BROWN
8	4	2	BROWN



## Specifications

RANGE	
Direct Connect	Up to 100m (330 ft) over solid core Cat 5e or better
Network Connect	Up to 100m (330 ft) between switches* over solid core Cat 5e
USB DEVICE SUPPORT	
Maximum Throughput	Up to 480Mbps*
Traffic Types	Interrupt and Bulk**
Device Types	HID (Mouse and Keyboard), Hubs, Storage Devices**
NETWORKING	
Standards	100BASE-T and 1000BASE-T*
Data Traffic	Layer 2
LOCAL EXTENDER (LEX)	
USB Connector	1 x USB 2.0 Type B Receptacle
Link Connector	1 x RJ45
Dimensions	100mm x 76mm x 26mm (3.9" x 3.0" x 1.0")
Enclosure Material	Silver Anodized Aluminum
REMOTE EXTENDER (REX)	
USB Connectors	4 x USB 2.0 Type A Receptacles
Link Connector	1 x RJ45
Dimensions	100mm x 76mm x 26mm (3.9" x 3.0" x 1.0")
Enclosure Material	Silver Anodized Aluminum
Available Current	600mA at each USB port concurrently
Power Supply	100-240V AC input, 24V 1A DC Output
ENVIRONMENTAL	
Operating Temperature Range	0°C to 50°C (32°F to 122°F)
Storage Temperature Range	-10°C to 60°C (14°F to 140°F)
Operating Humidity	20% to 80% relative humidity, non-condensing
Storage Humidity	10% to 90% relative humidity, non-condensing
COMPLIANCE	
EMC	FCC (Class B), CE (Class B)
Environmental	RoHS2 (CE)
SUPPORT	
Warranty	2 years

\* Maximum speed is heavily dependant on network configuration, bandwidth and performance.  
1000Base-T is highly recommended for best performance.

\*\* Isochronous devices such as webcams and audio devices are not supported.



*Distributed by:*

 45 Beechwood Dr., North Andover, MA 01845 www.L-com.com Fax: 978-689-9484 E-mail: sales@L-com.com Toll Free: 1-800-343-1455
--



**Icron Technologies Corporation**  
4664 Lougheed Highway, Suite 221  
Burnaby, BC Canada  
V5C 5T5

Tel: +1 604 638 3920  
Fax: +1 604 638 3930  
icron.com