

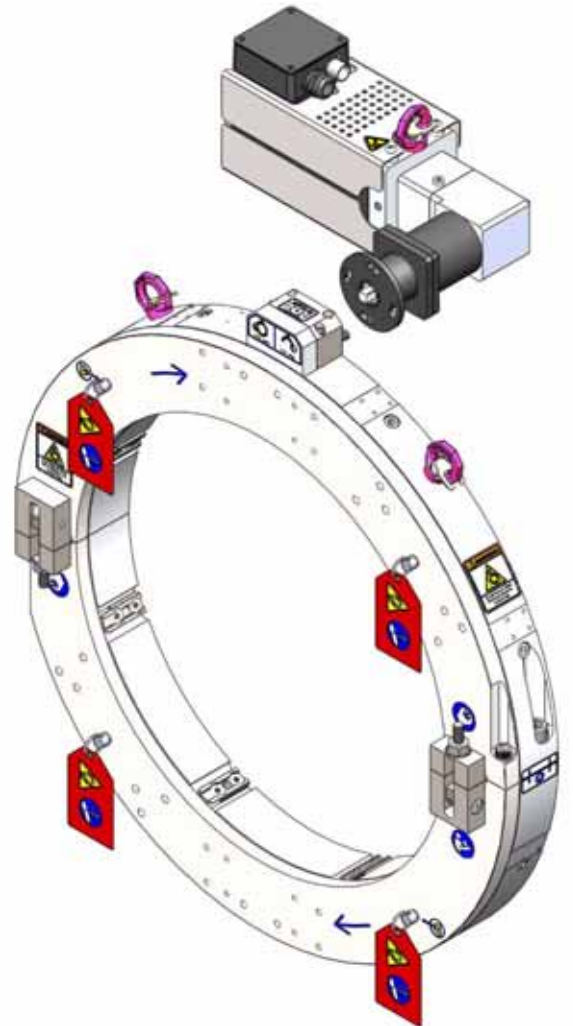

E.H. Wachs
600 Knightsbridge Parkway
Lincolnshire, IL 60069
www.ehwachs.com

Servo Drive Electric for LCSF and EP 424 User's Manual



E.H. Wachs Part No. 11-028-INST

Copyright © 2012 E.H. Wachs. All rights reserved.
This manual may not be reproduced in whole or in part
without the written consent of E.H. Wachs.

Servo Drive Electric for LCSF and EP 424

PURPOSE OF THIS DOCUMENT

This document explains how to operate E.H. Wachs low clearance split frame (LCSF) and EP 424 machines using the servo drive electric (SDE).

Each page is designed with two columns. This large column on the inside of the page contains instructions and illustrations. Use these instructions to perform the machining operation.

The narrower column on the outside contains additional information such as warnings, special notes, and definitions. Refer to it for safety notes and other information.



This is the **safety alert symbol**. It is used to alert you to **potential personal injury hazards**. Obey all safety messages that follow this symbol to avoid possible injury or death.

In This Document

PURPOSE OF THIS DOCUMENT
EQUIPMENT DESCRIPTION
OPERATING INSTRUCTIONS
MAINTENANCE
DRAWINGS AND SCHEMATICS



WARNING

A WARNING alert with the safety alert symbol indicates a potentially hazardous situation that **could** result in **serious injury or death**.



CAUTION

A CAUTION alert with the safety alert symbol indicates a potentially hazardous situation that **could** result in **minor or moderate injury**.



CAUTION

A CAUTION alert with the damage alert symbol indicates a situation that **will** result in **damage to the equipment**.



IMPORTANT

An IMPORTANT alert with the damage alert symbol indicates a situation that **may** result in **damage to the equipment**.



NOTE

A NOTE provides supplementary information or operating tips.



This is the **equipment damage alert symbol**. It is used to alert you to **potential equipment damage situations**. Obey all messages that follow this symbol to avoid damaging the equipment or workpiece on which it is operating.



NOTE

This symbol indicates a user note. **Notes** provide additional information to supplement the instructions, or tips for easier operation.

Read and follow all safety guidelines and instructions in the manual for your split frame machine.

EQUIPMENT DESCRIPTION

The servo drive electric (SDE) is a high-torque electric drive, with models designed for Wachs LCSF and EP 424 machines. Each model is available in three electrical configurations. Table 1 lists the SDE models and part numbers.

Table 1: SDE Models and Part Numbers

Voltage	LCSF Part No.	EP 424 Part No.
200-240 V	11-028-402	11-028-403
380-480 V	11-028-400	11-028-401
575 V	11-028-404	11-028-405

SDE models for the LCSF have a right-angle adapter (see Figure 1-3 below). SDE models for the EP 424 have a straight adapter (see Figure 1-4 below).

Each SDE model is provided with wiring for its specified electrical service.

The SDE system includes the following components:

- cart-mounted power supply cabinet with on/off and emergency stop buttons
- electric drive motor assembly with adapter for LCSF or EP 424
- control pendant with speed controls and emergency stop.

These components are shown in the following figures.

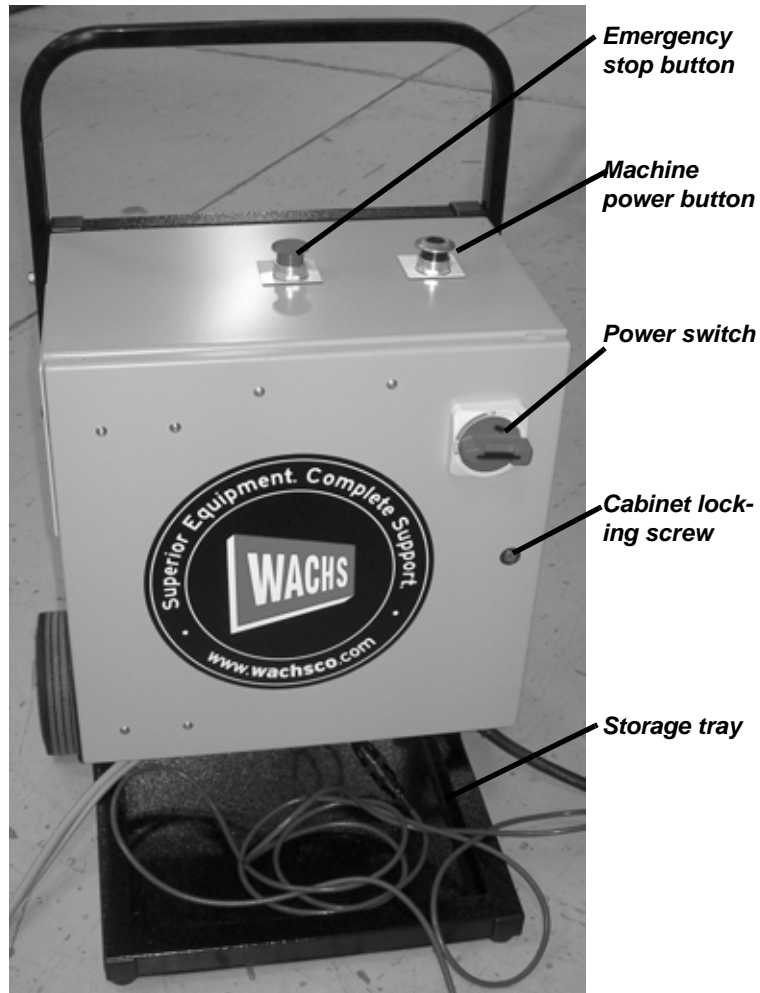

Figure 1-1. The photo shows the front of the control cabinet.

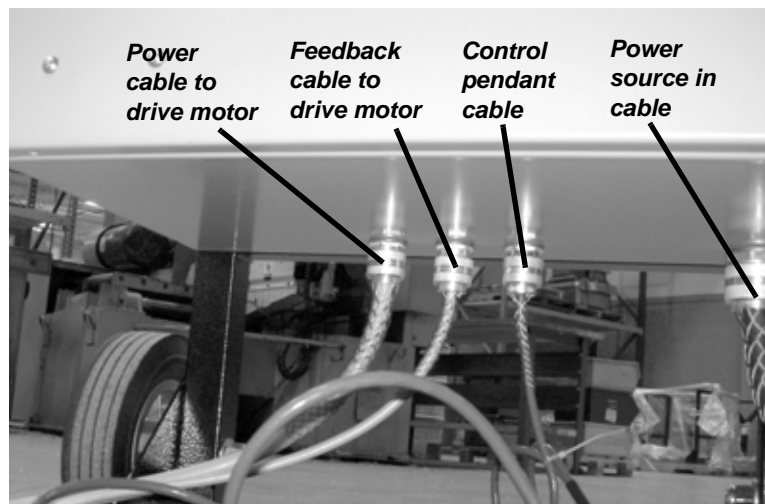

Figure 1-2. The cable connections are on the bottom of the cabinet. Only the pendant cable is removable.



Figure 1-3. The SDE for LCSF machines is equipped with a right-angle adapter. The adapter mounts directly to the standard pinion assembly.

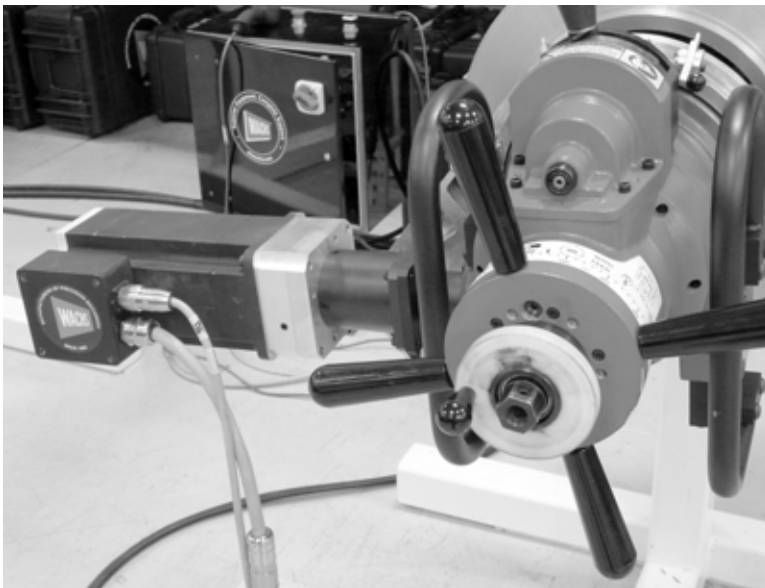

Figure 1-4. The SDE for the EP 424 uses a straight adapter. The adapter mounts directly to the standard drive mount.

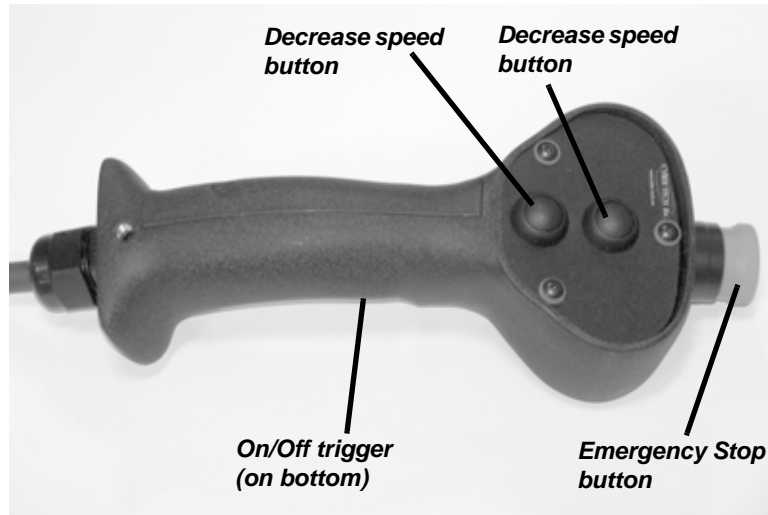

Figure 1-5. The control pendant is used to operate the SDE. It includes a 20 ft (6 m) cable.

OPERATING INSTRUCTIONS

Installing the SDE on the LCSF

It is recommended that you mount the SDE on the LCSF **before** connecting the cables. This reduces the chance of damaging the cables or connectors.

1. Mount the LCSF on the pipe according to the instructions in the LCSF user's manual.
2. Mount the SDE to the LCSF pinion assembly. Use a lifting device if necessary; the drive motor assembly has a lift eye.



NOTE

You can remove the screws from the pinion assembly to mount the SDE. Engage the square shaft in the pinion gear, then rotate the drive so you can install the screws.

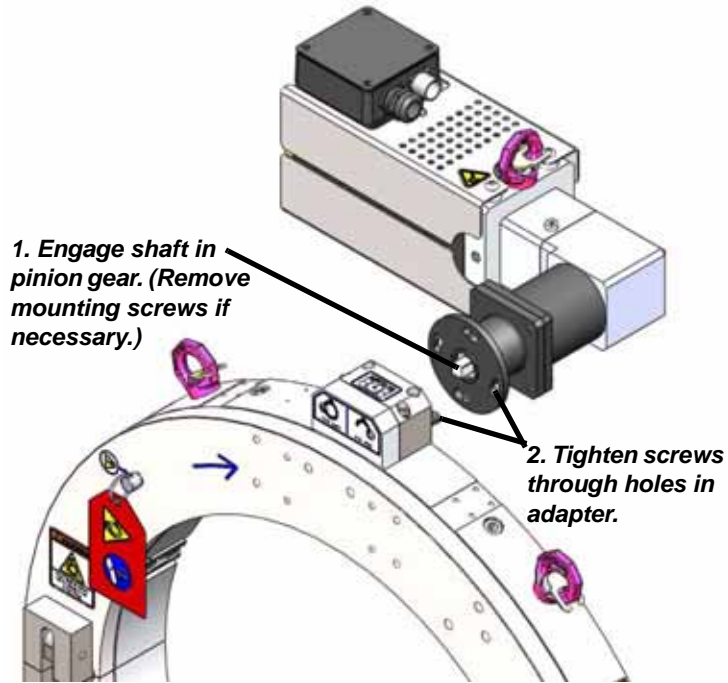

Figure 1-6. Mount the SDE to the pinion assembly on the LCSF.

3. Turn the SDE to engage the mounting screws in the adapter slots. Tighten the screws securely.

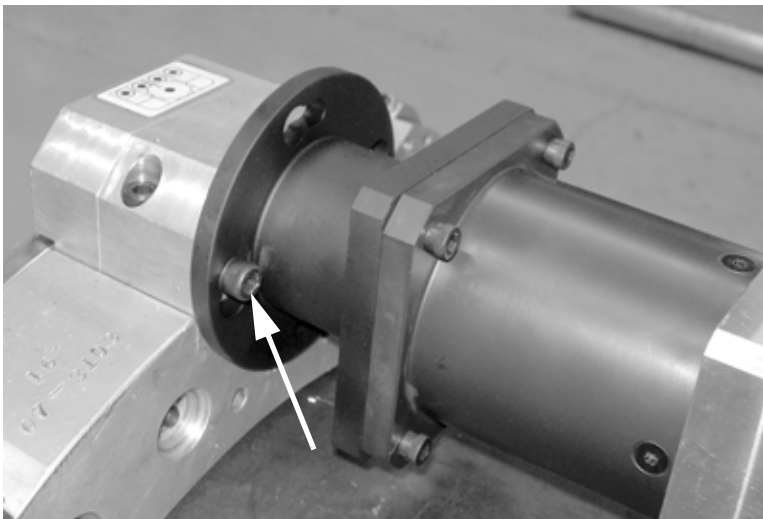

Figure 1-7. Insert the mounting screws and turn the drive to engage them in the slots. Tighten the screws (one each side).

Installing the SDE on the EP 424

It is recommended that you mount the SDE on the EP 424 **before** connecting the cables. This reduces the chance of damaging the cables or connectors.

1. Mount the EP 424 on the pipe according to the instructions in the EP 424 user's manual.
2. Mount the SDE to the EP 424 motor adapter. Use a lifting device if necessary; the drive motor assembly has a lift eye.

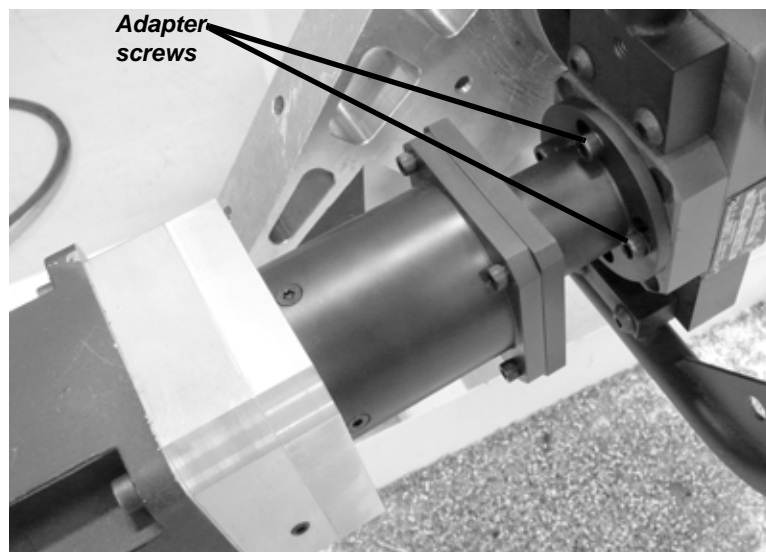

Figure 1-8. Install the drive on the EP 424 drive mount and secure it with the adapter screws.

3. Tighten the screws in the slots on the adapter to secure the drive.

Connecting the Cables and Using the Control Cabinet



NOTE

The cable is supplied from the factory without a wall plug. Install the appropriate plug for your electrical service.

1. A power cable for the appropriate electrical service is provided with the control cabinet. Connect it to the electrical source.
2. Connect the power and feedback cables from the control cabinet to the drive motor assembly. Screw the collars down to secure the connections.

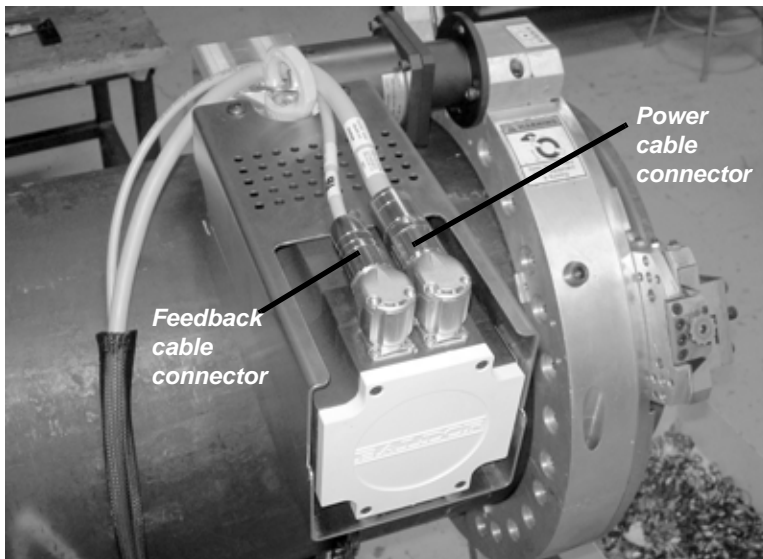

Figure 1-9. Attach the cables to the drive and tighten the collars.

3. If the pendant cable is disconnected, attach it to its connector on the bottom of the control cabinet.

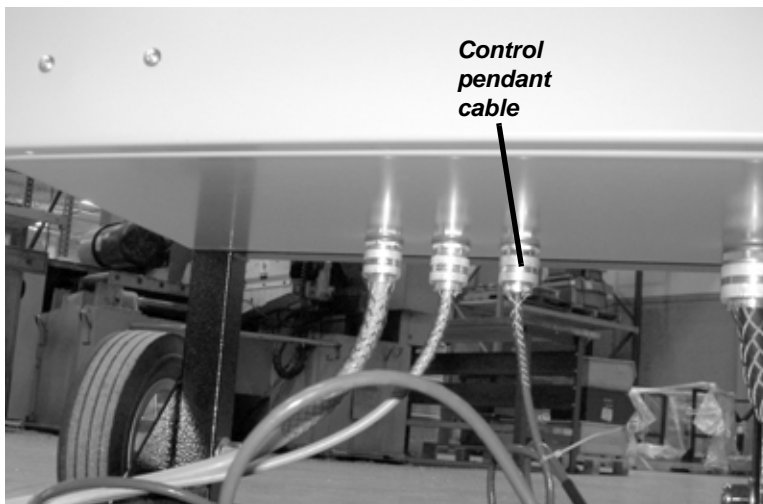

Figure 1-10. Connect the control pendant cable on the bottom of the cabinet.

Using the Control Pendant

The control pendant is enabled when the electrical system is powered on:

- Turn the power switch on the front of the cabinet to the ON position.



Figure 1-11. Turn the power switch to the ON position.

- Pull out the Emergency Stop and Machine Power buttons on the top of the cabinet.



*Figure 1-12. To enable the SDE, make sure the **Emergency Stop** button is pulled out, then pull the **Machine Power** button. The light in the center of the button will come on to indicate power is enabled.*

1. Squeeze the trigger on the control pendant to start the LCSF. The machine will start at minimum speed.



Figure 1-13. Squeeze the trigger to start the LCSF.

2. Use the **Increase Speed** button on the pendant to set the operating speed. Press and hold the button while holding the trigger until the desired speed is reached. To slow the machine down, use the **Decrease Speed** button.



NOTE

The speed resets to the minimum each time you release the trigger.

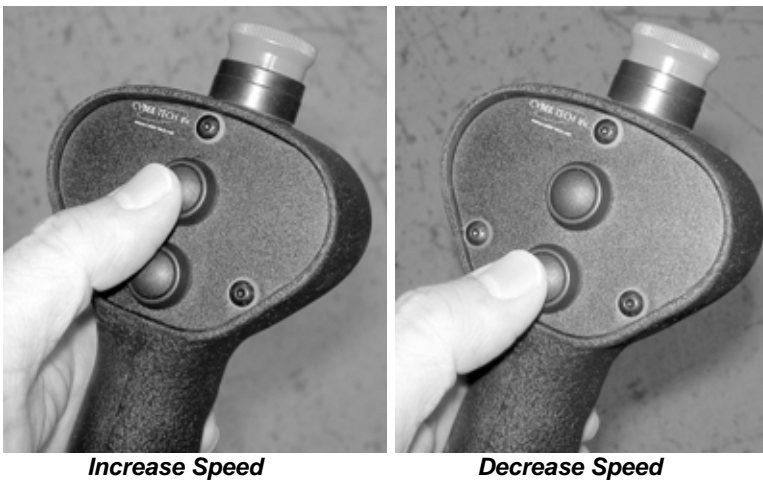

Increase Speed

Decrease Speed

Figure 1-14. Use the speed control buttons to set the machine's operating speed. You must be holding the trigger while adjusting the speed.

3. As the machine operates, continue holding the trigger and adjust the speed as necessary using the buttons on the control pendant. Release the trigger to stop the machine.



NOTE

After pressing Emergency Stop (either on the cabinet or the pendant), you will have to re-enable power using the **Machine Power** button on the cabinet.

4. Press the Emergency Stop button on the pendant to immediately stop the machine and disable power.



Figure 1-15. Push down the Emergency Stop button on the pendant to stop the machine and shut down power to the drive.

MAINTENANCE

The SDE does not require any lubrication. Mechanical components are sealed and lubricated for life.

The control cabinet has two air filters. Check these filters periodically, and clean or replace them as necessary.

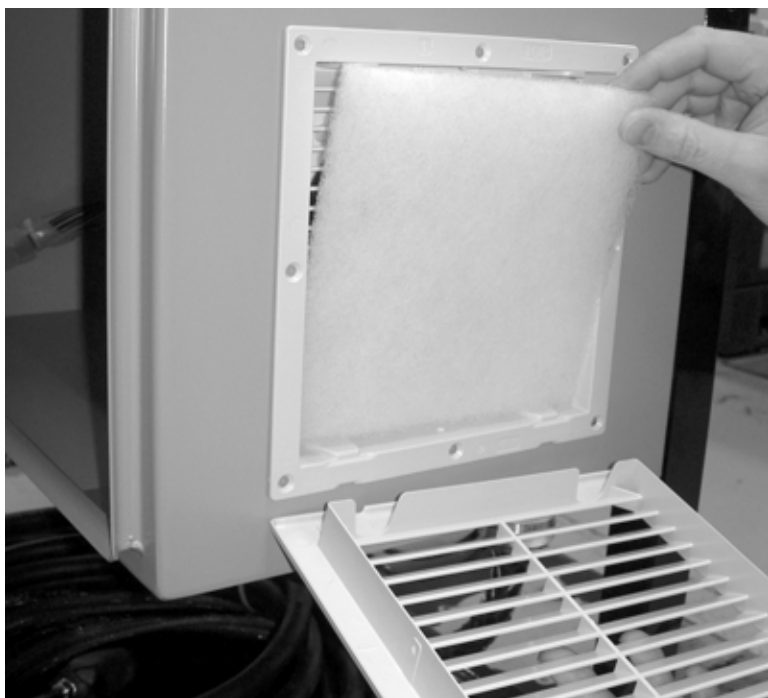

Figure 1-16. Remove the filter cover to check or replace the air filter. The control cabinet has 2 filters, one on each side.

Opening the Cabinet for Electrical Service

You may need to open the control cabinet to replace fuses or perform other service. See the electrical schematic at the end of this document for fuse identification.

1. Turn the power switch on the cabinet to the OFF position.



WARNING

Do not open the cabinet when power is connected to it. Electrical shock can cause serious injury or death.



Figure 1-17.

2. Disconnect the cabinet from the power supply.
3. Loosen the screw in the cabinet door.



Figure 1-18. Loosen the screw before opening the cabinet door.

4. Press the locking tab on the power switch down to open the cabinet door.

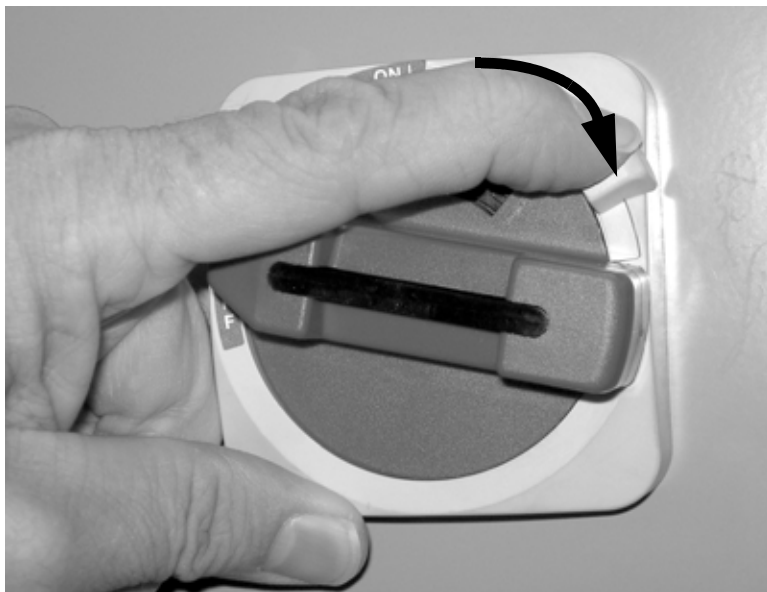

Figure 1-19. Push down the locking tab on the switch to open the door.

5. The fuse block is shown in fig. If necessary, replace blown fuses.

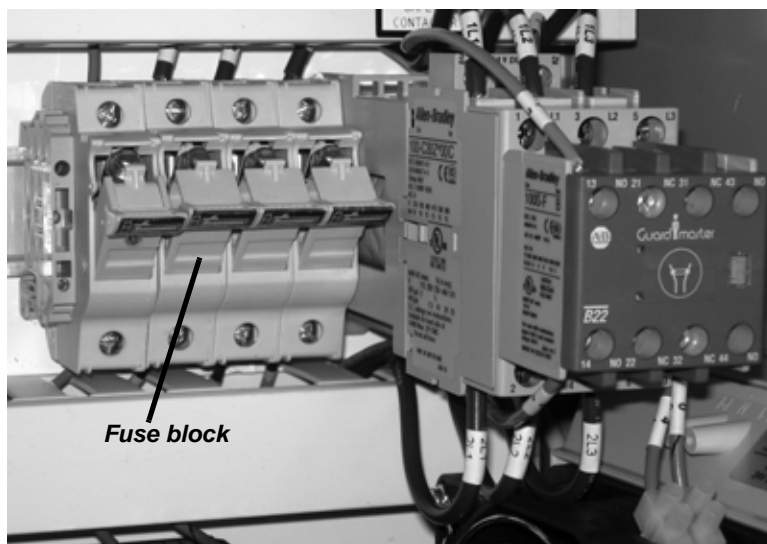

Figure 1-20. The fuse block is accessible with the cabinet door open.

6. Close the cabinet door and press it shut until the locking tab in the switch “clicks” into place.
7. Tighten the cabinet door screw.

DRAWINGS AND SCHEMATICS

The follow pages illustrate the components and the electrical schematics of the SDE system.

CONTROL ENCLOSURE FOR 380-480V

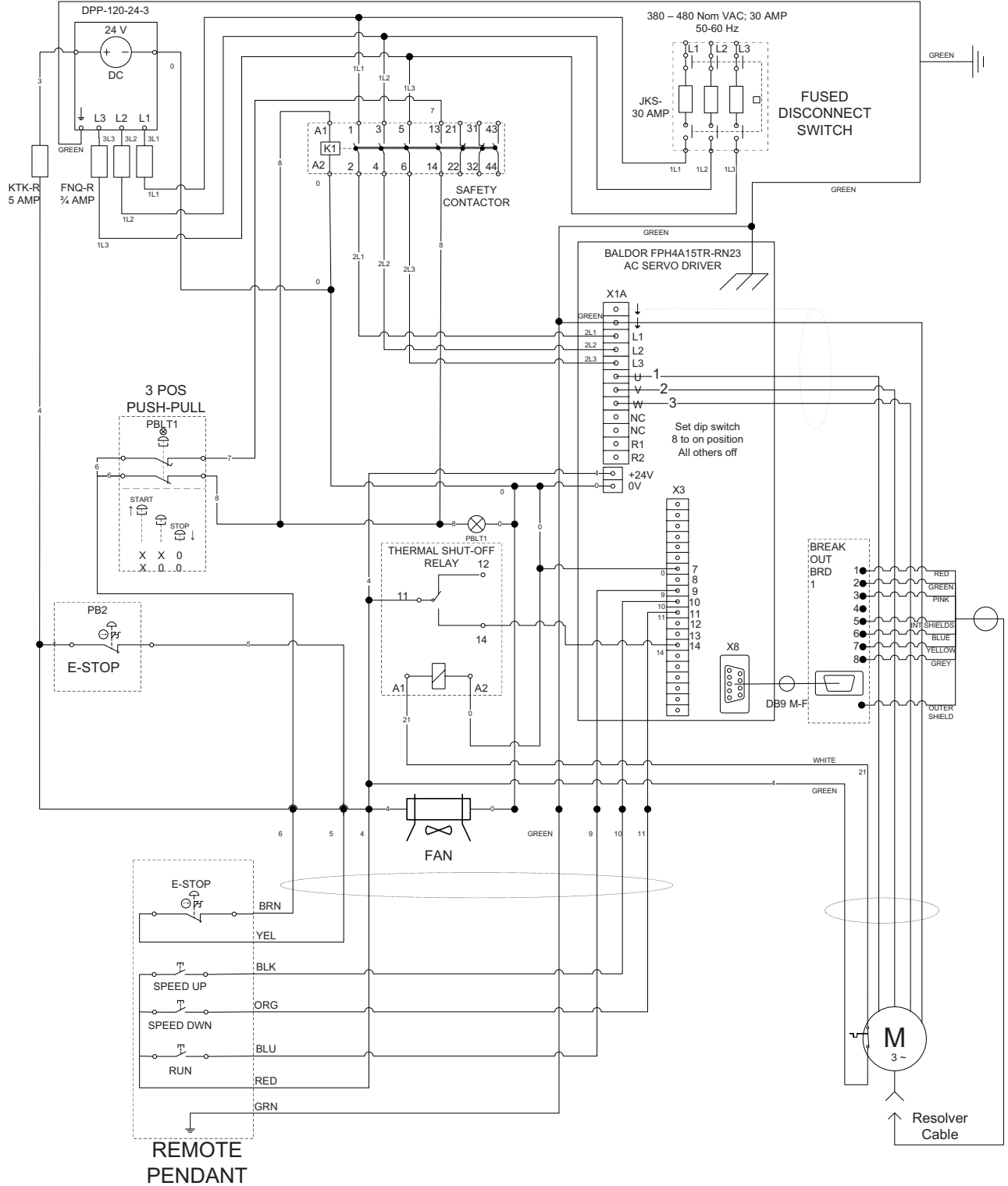

CONTROL ENCLOSURE FOR 200-240V

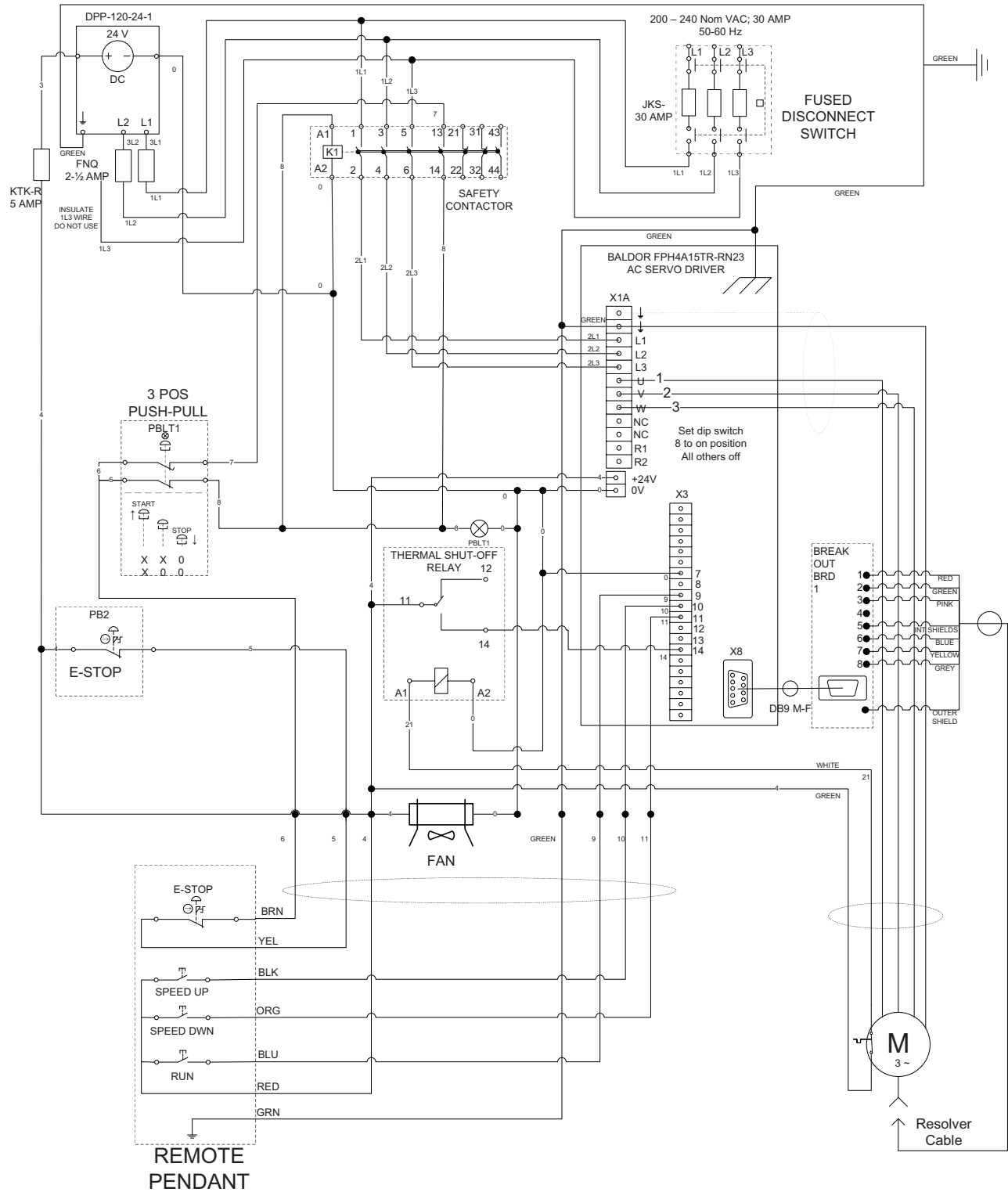



600 Knightsbridge Parkway • Lincolnshire, IL 60069
847-537-8800 • www.ehwachs.com