

# M930

## *Battery operated magnetic flowmeter*

User's manual





<b>1</b>	<b>Basic information</b>	<b>5</b>
1.1	Basic features	5
1.2	Standards and approvals	5
1.3	Warranty	6
<b>2</b>	<b>Preparing for start up</b>	<b>7</b>
2.1	Inspecting contents of the package	7
<b>3</b>	<b>Installation</b>	<b>8</b>
3.1	Sensor location	8
3.2	Battery connection	11
3.3	Battery replacing	11
3.4	Electric connection between converter and sensor – Remote version	11
3.5	Sensor grounding	12
<b>4</b>	<b>Electronic unit description</b>	<b>13</b>
4.1	Front panel (display)	13
4.2	USB	14
<b>5</b>	<b>Operation</b>	<b>15</b>
5.1	Main menu	15
5.1.1	Total Volume	15
5.1.2	Current Flowrate	15
5.1.3	Positive and Negative Volume	15
5.1.4	Auxiliary Volume	15
5.1.5	Datalogger (periodical flow rate record)	15
5.2	Internal backup system	16
5.3	Menu - Basic rules (MENU)	16
5.4	Setup menu (SETUP)	16
5.4.1	Flowmeter configuration (FLOWMETER)	16
5.4.1.1	Flowrate parameters (FLOW)	16
5.4.1.2	Volume parameters (VOLUME)	17
5.4.1.3	Datalogger parameters (DATALOGGER)	18
5.4.2	Calibration menu (CALIBRATION)	18
5.4.2.1	Number of Calibration Points (Num.of cal.point)	19
5.4.2.2	Calibration point 1 (CAL.POINT 1)	19
5.4.2.3	Calibration point 2 (CAL.POINT 2)	19
5.4.2.4	Calibration point 3 (CAL.POINT 3)	19
5.4.2.5	Calibration point 4 (CAL.POINT 4)	19
5.4.2.6	Original calibration settings (Orig. cal. settings)	19
5.4.3	General settings (GENERAL)	19
5.4.3.1	Interface parameters (USB-RS232)	19
5.4.3.2	Display parameters (DISPLAY)	20
5.4.3.3	Real time setting (DATE/TIME)	20
5.4.3.4	Password setting (USER ACCESS)	20
5.4.3.5	Battery administration (BATTERY)	20
5.4.3.6	Service information (INFO)	21
5.5	Nominal values (standard factory setting)	22
<b>6</b>	<b>System control</b>	<b>23</b>
6.1	Command syntax	23
6.2	Command list	24
6.2.1	Main menu	24
6.2.2	Flowmeter	25
6.2.2.1	Flowrate parameters	25

6.2.2.2	Volume parameters	27
6.2.2.3	Datalogger parameters	28
<b>6.2.3</b>	<b>Calibration</b>	<b>31</b>
<b>6.2.4</b>	<b>General</b>	<b>31</b>
6.2.4.1	Display parameters	31
6.2.4.2	Real time clock setting	32
6.2.4.3	Password setting	33
6.2.4.4	Service information	34
6.2.4.5	Error messages	35
<b>7</b>	<b>Error messages</b>	<b>36</b>
<b>8</b>	<b>Maintenance</b>	<b>37</b>
8.1	Advice for correct operation	37
8.2	Periodical maintenance	37
8.3	What to do in case of failure	37
<b>9</b>	<b>Application information</b>	<b>38</b>
9.1	Weight and dimensions	38
9.1.1	Electronic unit – compact version	38
9.1.2	Electronic unit – remote version	38
9.1.3	Sensor	39
9.2	Used materials	40
9.3	Flowrate versus diameter	41
<b>10</b>	<b>Type plate</b>	<b>42</b>
<b>11</b>	<b>Technical data</b>	<b>44</b>
<b>12</b>	<b>Ordering information - options</b>	<b>45</b>
12.1	Example of order	45
<b>13</b>	<b>Terminology</b>	<b>46</b>
<b>Appendix A</b>	<b>Measuring principle</b>	<b>47</b>
<b>Appendix B</b>	<b>M930 Menu structure</b>	<b>48</b>

## 1 Basic information

### 1.1 Basic features

**The inductive flow meter M-930** is designed to measure, indicate and record the instantaneous and total flow of the conductive media flowing through the sensor. The flow meter M-930 records both forward and reverse flows. As there are no moving parts in the flow profile the M-930 can be used to measure extremely dirty liquids containing solids. The only limitation is that the flowmeter can be used solely with conductive liquids.

**Range of applications.** The inductive flow meter M-930 is for use in the Chemical Industry, Paper Industry, Water and Wastewater Treatment Industry and most other process industries.

**Features.** The inductive flowmeter M-930 is a highly accurate and stable device. The construction of the M-930 flowmeter uses components with long-term, time and temperature stability. Configuration data is backed up and can be recovered after a power failure. The back-up structure enables data recovery even if a partial loss of data occurs as a result of (e.g. high level electrostatic discharge or a noisy power supply). Internal CPU provides all functions usually built in electronic flow meters, incl. low flow rate correction, frequency response setting, bandwidth of sensitivity setting at low flow rates, etc.

**Power supply.** M930 is supplied from internal lithium battery and doesn't requires external power supply.

### 1.2 Standards and approvals

Electromagnetic flowmeter is conformed to requirements for bearing CE mark.



- Electromagnetic flowmeter electronic unit, both remote and compact version meet safety requirements according to standard EN 61010-1 including amendment A2.
- Electromagnetic flowmeter electronic unit, both remote and compact version meets EMC requirements according to standard EN 61000-3, EN 61000-4, EN 61000-6
- Pipe with sensor meets requirements of Pressure Equipment Directive 97/23/EC.
- Both the pipe and electronic unit, meet the requirements of degree of protection provided by enclosure level IP67, according to EN 60529 (IEC 529).

### **1.3 Warranty**

Within the manufacturers general supply conditions, all material and manufacturing faults are covered by that. It is up to us whether the warranty obligation includes a repair free of charge or corresponding replacement. Place of the warranty obligation is Czech Republic. Further claims on compensation, especially for loss of production or resultant of damages, are strictly excluded.

Any defects caused by improper use are absolutely not included in the warranty. Excluded from warranty are also expendable items (as i.e. accumulators, batteries, pushbuttons after attained life time, ribbons, etc.)

In case of a warranty claim the user is asked to give detailed description of the defect and also of the application for which you use the product. This information is important in order to avoid time and cost extensive tests and for the eventual achievement of warranty claims from our suppliers and sub-suppliers. For the item or instrument, returned after the expired warranty time, repair or replacement on warranty can only be accepted, if manufacturer has been informed in time that a warranty case has occurred.

Warranty period for all types of electromagnetic flowmeter is 24 months.

***The flowmeter should only be used according to the instructions described in this operating manual.***

## 2 Preparing for start up

### 2.1 Inspecting contents of the package

Basic package includes the following items:

- Flanged sensor
- Electronic Transmitter (can be integral or remote)
- Operating manual.
- Calibration certificate
- Special wrench for opening the housing covers
- Software FlowAssistant
- USB A-B cable

The flowmeter is delivered ready for use after connecting to the power supply. Please check that it has been correctly installed according to chapter “Installation”.

## 3 Installation

### 3.1 Sensor location

To avoid measuring errors due to gas/air entrainment or to a partly filled pipe, please observe the following:

#### Horizontal (standard) mounting

The sensor tube must always remain full. The best way to achieve this is to locate the sensor in a low section of pipe, see the following picture. It is recommended to install the sensor in a section of straight pipe with at least 5 times the pipe diameter before sensor and 3 times after sensor.

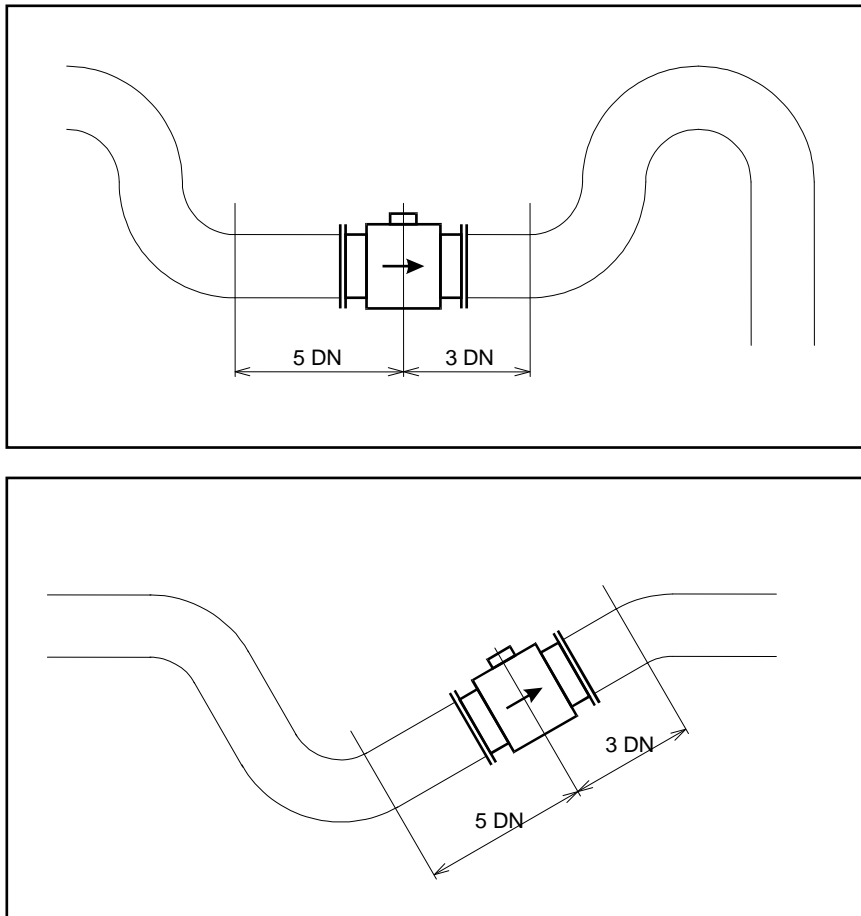

#### Pipe reducers

If the pipe diameter is not the same as the diameter of sensor, then pipe reducers can be used. So as not to lose accuracy of the measurement, the slope of reducers should not exceed  $8^\circ$ .



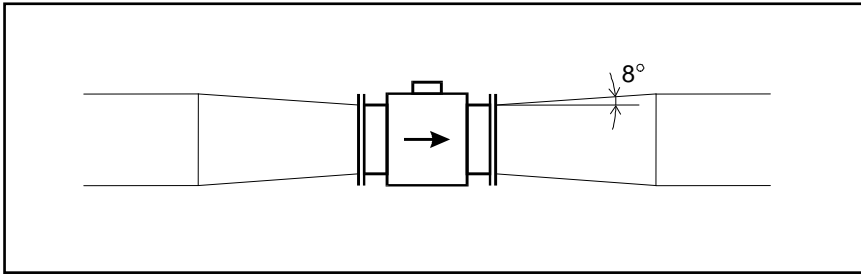

### Vertical mounting

When the sensor is mounted on a vertical section of pipe, the flow direction must be upwards. In the case of a downward flow direction, air bubbles can collect in the sensor and the measurement could be unstable and inaccurate.

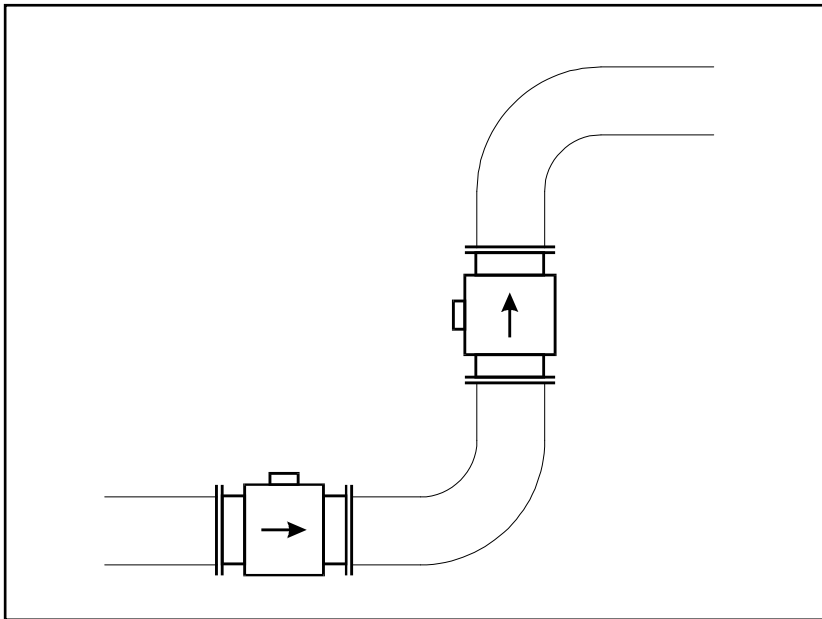

### Pumps

Never install the sensor on the suction side of a pump or on a section of pipe where a vacuum is possible.

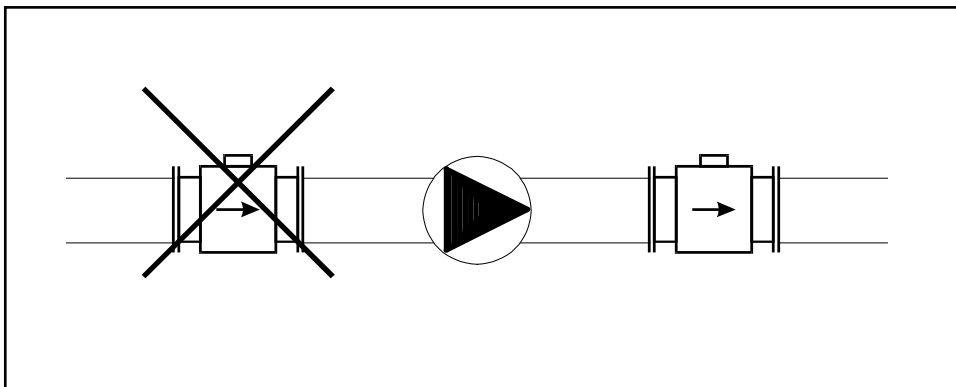

**Valves**

Suitable location of a shutoff valve is downstream of a sensor.

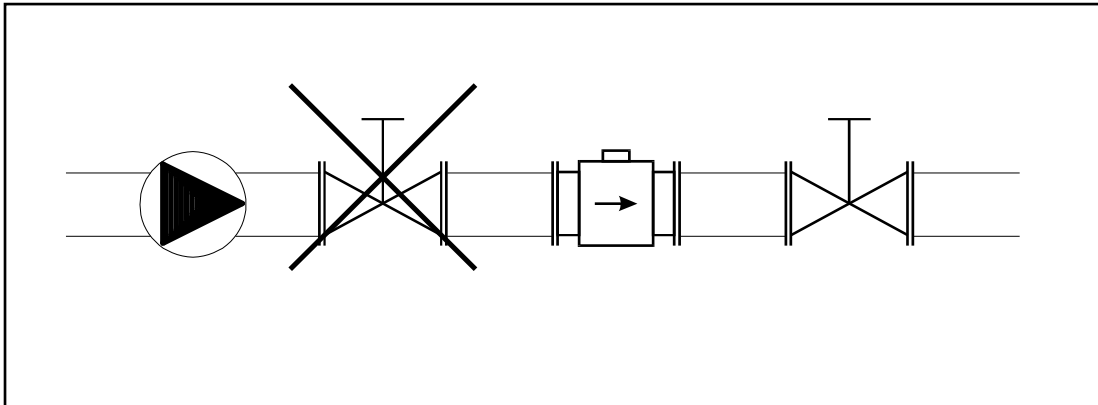

**Removal during maintenance**

If the application requires removal of the sensor for periodic maintenance, it is recommended to install a bypass section as the following drawing.

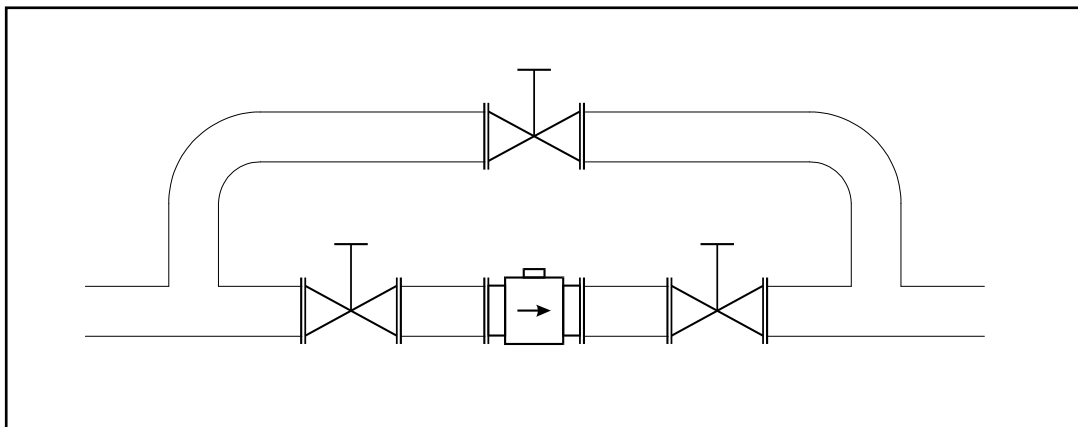

**Position of electrodes**

The axis of measuring electrodes must be approximately horizontal (see picture).



### Vibration

To avoid mechanical damage protect both electronic unit and sensor against mechanical vibrations. When strong vibrations are possible, both the input and output pipe must be mechanically fixed or the remote version with a separate electronic unit should be used.

### Overheating

To avoid overheating, the electronic unit should be protected against direct sunlight especially in areas with a warm climate with ambient temperatures over 30 °C. If necessary a sunshade has to be mounted over the electronic unit or a remote version with a separate electronic unit should be used.

### 3.2 Battery connection

The flowmeter is delivered with disconnected internal battery. Following procedure should be used to connect battery after installation the flowmeter.

- Unscrew the back cover using the special wrench (standard part of delivery).
- Connect the 10 pin flat cable to the connector (highlighted in the picture).
- Screw on the back cover.

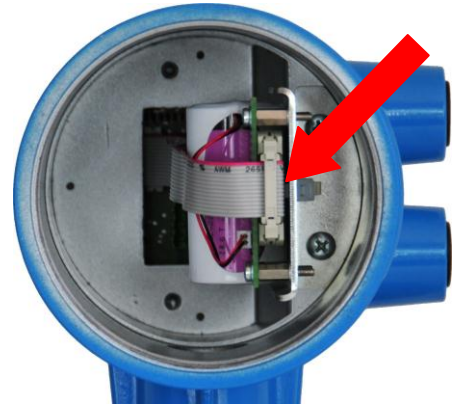

### 3.3 Battery replacing

The battery life time depends on excitation frequency, flowmeter settings and ambient temperature.

Terms shortening battery life:

- Short excitation time
- USB connecting
- Active display

If the battery indicates low state, remove the battery by the following steps:

- 1) Activate MENU → SETUP → GENERAL → BATTERY → Change new (yes)  
You will be prompted to inserting new battery.
- 2) Insert new battery
- 3) Check date and time

### 3.4 Electric connection between converter and sensor – Remote version

For remote version converter and flanged sensor are connected with two (2-wire unshielded and 3-wire shielded) cables. Standard length of cables is 6 meter. It is recommended to mount the transmitter not too far from the flanged sensor. Use cables as short as possible.



Five-terminal connector is located in separated box. The same box is used for the converter and also for the sensor. Colours of wires are following:

3-wire shielded cable (shielding is connected to the green wire):

Blue (Brown) :	Electrode 1 (EL1)
Green :	Ground
Red (White):	Electrode 2 (EL2)

2-wire cable:

Brown :           Excitation 1 (EXCITATION)  
White :           Excitation 2 (EXCITATION)

Following procedure should be observed to connect sensor cable to the transmitter or sensor:

- Switch off power supply.
- Dismount top cover of connection box. Four screws must be removed.
- Connect 5 wires to the connector.
- As the basic protection of connection box is IP65 it is important (in case you need better protection) to fill the box (with connected wires) with reenterable insulating and sealing compound. One piece of compound is standard part of delivery. Using this technology will be protection of transmitter IP67 and protection of sensor IP68.
- Mount the cover back.
- Switch on power supply.



### 3.5 Sensor grounding

To ensure the correct operation of the flowmeter an earthing connection between the sensor and pipeline must be made. The sensor is equipped with screw connection for an earthing wire. This screw has to be connected to the flange on the pipeline. Use Copper wire to connect between the flange and the earth screw on the sensor.

If the pipeline is manufactured from a non-electrically conductive material, or if the pipe is lined with a similar material, special grounding rings must be installed between flanges.

*Note: The flowmeter must not be switched on, if the sensor is not connected /earthed to the rest of pipeline!*

Sensor grounding without grounding rings

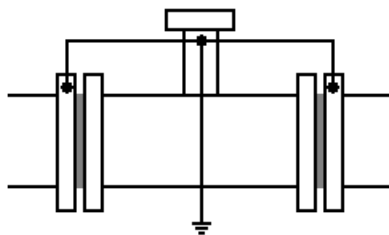

Sensor grounding with grounding rings

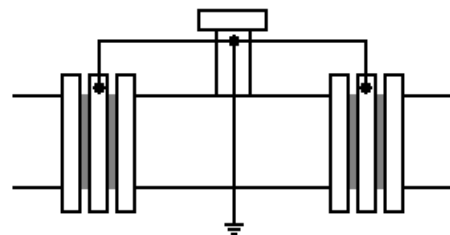

## 4 Electronic unit description

### 4.1 Front panel (display)



#### 1 Capacitive buttons

Two capacitive buttons allows control of all flowmeter's functions. Buttons are activated by placing a finger on isolated area. Both buttons has two levels of activation (short and long activation). Functions for both levels are shown on display

Short activation – less than 0,7 s.

Long activation – more than 0,7 s

Example:



Top button: Short activation switches display to the next window. Long activation resets auxiliary volume.

Bottom button: Short activation displays flow meter's MENU. There is no function for long activation.

#### 2 Display

Graphic LCD is used to display the total volume, instantaneous flowrate, actual function of capacitive buttons and auxiliary information.

The type of units can be changed in the flowmeter "Setup Menu" (see chapter "Flowmeter configuration").

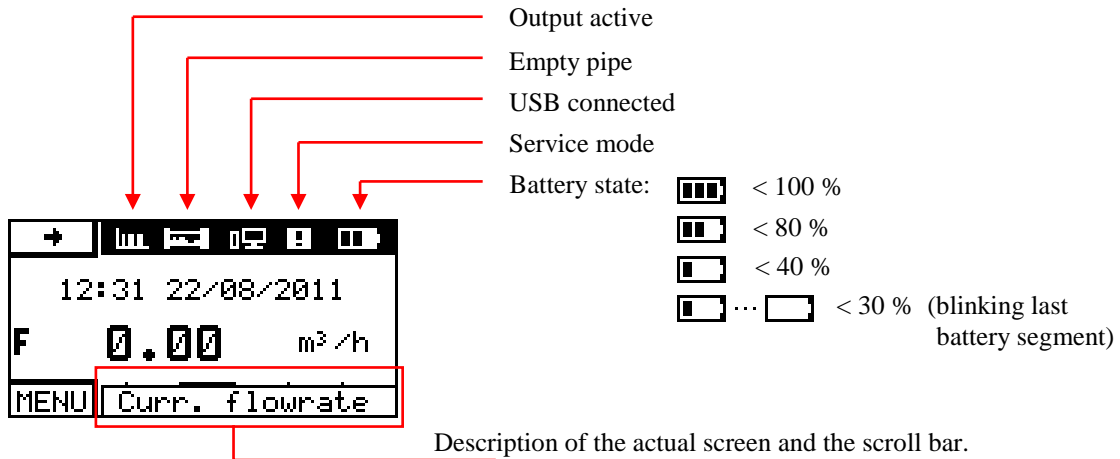

If you don't use the display for 30 s, display goes to sleep mode. The flowmeter continues with measuring. Waking up is done by activating any button for 1 s.

### 3 USB connector

USB for connection the flowmeter to the computer. USB is electrically isolated from the flowmeter electronics.

### 4.2 USB

The connector is located on the front panel and is accessible after removing the electronic unit cover. USB enables you to connect the flowmeter to a personal computer. USB can be used for flowmeter's configuration and calibration. It's not suitable for online communication during operation, because the flowmeter must be open (IP67 protection is lost).

Baud rate	9600 Bd
Data bits	8
Stop bit	1
Parity	none

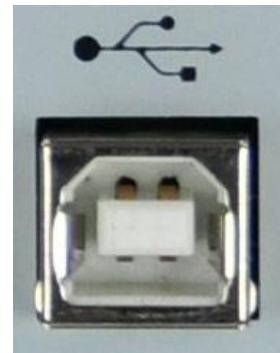

For connection of the flowmeter to the PC a standard USB A-B cable is used. To connect a PC to the flowmeter, follow this procedure:

- Unscrew the front cover using the special wrench (standard part of delivery).
- Plug the one end of the cable onto the USB connector in the flowmeter.
- Connect the opposite end to the USB port in the PC.
- Use the application software (FlowAssistant) to enter new calibration data or to change settings of the flowmeter.
- Disconnect USB cable and replace the cover.

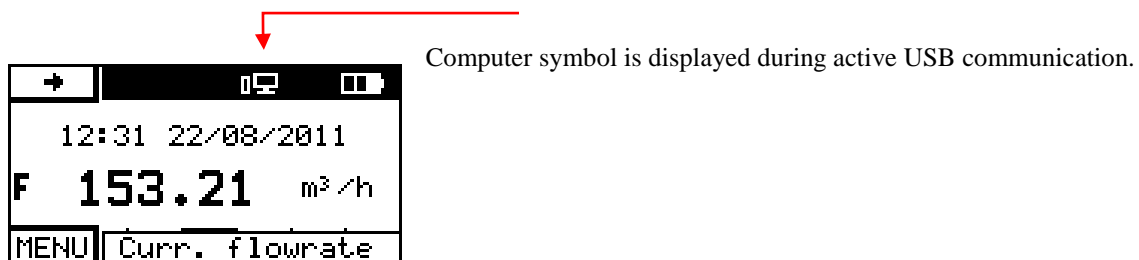

Note: USB port is galvanically isolated from other electronic circuits.

## 5 Operation

### 5.1 Main menu

The flowmeter is in *Main menu* after the switching power on. This entire menu can be operated with capacitive buttons without opening the housing.

The following information can be displayed in the *Main Menu*.

#### 5.1.1 Total Volume

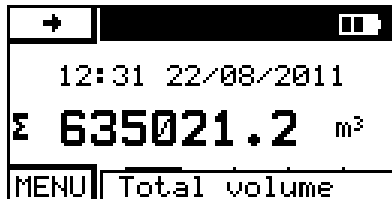

Basic display (after power on). Time is displayed on the second line. Total volume is displayed on the second line. Flow in the forward direction is added to this volume, Flow in the reverse direction is subtracted. Measuring parameters (units, moving average etc.) are selectable in *Setup menu*. “Current Flowrate” is displayed after pushing “→” key.

#### 5.1.2 Current Flowrate

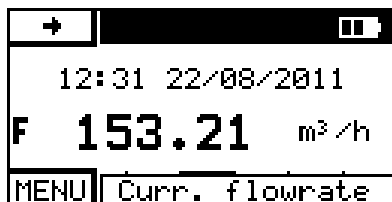

Time is displayed on the first line. Current flowrate is displayed on the second line. Measuring parameters (units, moving average etc.) are selectable in *Setup menu*. “Positive / Negative Volume” is displayed after pushing “←” key.

#### 5.1.3 Positive and Negative Volume



Total volumetric flow in a forward and a reverse direction. “Auxiliary Volume” is displayed after pushing “→” key.

#### 5.1.4 Auxiliary Volume

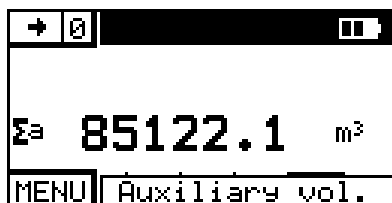

Second Total Volume counter. Value is cleared after pushing “0” key (top button long activation). This operation must be enabled in *Setup menu*. It is usually used for measuring volumetric flow during a set period such as day, month etc.. “Datalogger” is displayed after pushing “→” key.

#### 5.1.5 Datalogger (periodical flow rate record)



Individual samples from datalogger memory can be read after pushing “↓” key. In this submenu samples are read sequentially. Next sample (Flowrate with Date and Time) is displayed after pushing “↓” key. “Sequential reading” submenu is left after pushing “→” key or after displaying all values. “Current Flowrate / Total Volume” is displayed after pushing “→” key. Datalogger capacity is 100 000

samples.

Main menu windows are switched by pushing “→” key.

## 5.2 Internal backup system

Once an hour some data is saved to internal FLASH (Date and time, Total volume, Positive volume and Negative volume). If you want change the battery, see “3.3 Battery replacing”. Menu settings, datalogger etc. are saved immediately.

## 5.3 Menu - Basic rules (MENU)

Using the Setup menu can be changed all parameters of the flowmeter. Menu is organized as tree type structure. Meaning of keys is:

„↑“	- parameter selection
„OK“	- confirmation of selected parameter
„C“	- return one level back

The folder names are written in capital letters, individual items are written small letters.

## 5.4 Setup menu (SETUP)

In this menu the flowmeter parameters can be changed. Access to the Setup menu is after pushing the “MENU” key from the Main menu. Access is protected by password.



Correct password must be entered before entering Setup menu. Without correct password the access to the Setup menu is refused. Default factory password is “00000”. Password is entered by pressing “↑”, “→” keys and confirmed by pressing the “OK” key. Return to the main menu is possible by pressing the “C” key.

After entering correct password the flowmeter displays actual access level for app. 3s. There are three levels of access (according to the password):

- 1) BASIC – default value is 00000. This level allows changing user settings of the flowmeter.
- 2) CALIBRATION – default value is 10000. This level allows changing user settings and calibration data.
- 3) SERVICE – only for service engineers.

## 5.4.1 Flowmeter configuration (FLOWMETER)

Item serves for the flowmeter configuration. After pushing “↓” key next item (“CALIBRATION”) is selected. After pushing “OK” key following menu is displayed:

### 5.4.1.1 Flowrate parameters (FLOW)

Function enables you to set flowrate unit, resolution and other flowrate parameters.

#### 5.4.1.1.1 Flowrate units (Unit)

This item allows to set flowrate units.

Available units are:

l/s	litres per second
m <sup>3</sup> /h	cubic metres per hour
UG/m	US gallons per minute
IG/m	imperial gallons per minute



User user-defined unit, factory-set is „l/h“ (litres per hour), user defined unit can be changed by computer only

#### 5.4.1.1.2 User unit name (User unit)

This item allows to set the name of user unit. Maximal length is five letters.

#### 5.4.1.1.3 User unit conversion constant (User constant)

This item allows to set the conversion constant for user unit. This constant is calculated as the ratio between flowrate in [l/s] and flowrate in [user unit]. CALIBRATION access is required.

#### 5.4.1.1.4 Flowrate direction (Direction)

This item allows to switch between “Positive” and “Negative” flow direction (change the sign in flowrate value).

*Note: Flowmeters are working in both flow directions. However standard calibration is made for positive direction only.*

#### 5.4.1.1.5 Low-flow cutoff (Low-fl.off)

This item allows to set limit for suppressing low flowrates. Available range is according to the nominal diameter.

*Note: All flowrates below this value will be displayed as 0.00. This setting is valid for display and all outputs.*

#### 5.4.1.1.6 Coils excitation time (Excitation)

This items allows to set the time between flow measurement. The value has a significant impact on battery life. Following frequencies can be set:

1 s	battery life 5 months
5 s	battery life 30 months
15 s	battery life 5 years
30 s	battery life 7 years

#### 5.4.1.1.7 Moving average time constant (Time const.)

This item allows to change the time for moving average calculating. Available range is between 4 and 20 s.

#### 5.4.1.1.8 Nominal flowrate range (RANGE)

Function enables you to change the nominal flowrate range. This is the auxiliary constant for easy configuration of flowmeter’s outputs. There is no dependency between flowmeter’s accuracy and this constant.

### 5.4.1.2 Volume parameters (VOLUME)

This item allows to set volume unit, resolution and other volume parameters.

#### 5.4.1.2.1 Volume units (Unit)

This item allows to set volume units.

Available units are:

l	litres
m3	cubic metres
UG	US gallons
IG	US gallons
User	user-defined unit, factory-set is „l“ (litres), user defined unit can be changed by computer only

#### 5.4.1.2.2 User unit name (User unit)

This item allows to set the name of user unit. Maximal length is four letters.

#### 5.4.1.2.3 User unit conversion constant (User constant)

This item allows to set the conversion constant for user unit. This constant is calculated as the ratio between volume in [l] and volume in [user unit]. CALIBRATION access is required.

#### 5.4.1.2.4 Resetting Volume counters (CLEAR VOLUME)

This item allows to clear volume counters.

“Auxiliary volume” clears auxiliary volume counter.

“Total volume” clears total volume counter (CALIBRATION access is required).

“Pos/Neg volume” clears positive and negative volume counter (CALIBRATION access is required).

#### 5.4.1.3 Datalogger parameters (DATALOGGER)

This item allows to set the datalogger.

##### 5.4.1.3.1 Datalogger sampling interval (Interval)

This item allows to set sample interval for internal datalogger. You can select one of following intervals: Off, 5, 10, 15, 30, 45, 60, 120, 180 and 240. Values are expressed in minutes. Flowrate value written into the datalogger is calculated as average value in the selected interval.

##### 5.4.1.3.2 Datalogger filling (Filling)

This item displays datalogger filling in %. Datalogger capacity is over 100 000 samples.

##### 5.4.1.3.3 Datalogger clear(Clear)

This item allows to clear the datalogger memory.

#### 5.4.2 Calibration menu (CALIBRATION)

This item serves for the flowmeter calibration.

**Setting any new value in calibration menu changes calibration data! Calibration should be performed in an appropriate equipped laboratory.**

**We recommended using software FlowAssistant for easy Calibration. It contains „calibration wizard“ and can prevent flowmeter from incorrect calibration.**

You can change calibration values only if the correct calibration password has been entered. Default factory setting is “10000”.

*Note: Flowmeter M930 enables calibration at 2, 3 or 4 points. Each calibration point contains 2 values. Nominal value of calibration point is selected by user in range between +/-  $Q_{MAX}$  (for maximum flowrates see table 1: M930 flowrates). It is expressed in flowrate units. To this nominal value is attached a calibration constant. Calibration constant doesn't have a unit. In the calibration process you change this calibration constant to reach similarity between standard flowmeter and the calibrated flowmeter. Higher calibration constant means lower displayed value. Calibration constants must be different. In the case of two equal calibration constants, the measured values could be wrong.*

#### 5.4.2.1 *Number of Calibration Points (Num.of cal.point)*

This item allows to enter number of calibration points in range between 2 and 4.

*Note: Standard number of calibration points is 2. More calibration points are used for special applications when higher accuracy is expected (negative flowrate, low flowrates etc.).*

#### 5.4.2.2 *Calibration point 1 (CAL.POINT 1)*

This item allows to change nominal and calibration value of Calibration point 1.

##### 5.4.2.2.1 *Flowrate nominal value setting (Flowrate)*

Flowrate nominal value can be changed in the range +/-  $Q_{MAX}$  (see the table 1: M930 flowrates). This value is flowrate that is calibrated.

##### 5.4.2.2.2 *Calibration constant (Constant)*

Value presents calibration constant in above defined calibration point. Higher calibration constant means lower displayed value.

#### 5.4.2.3 *Calibration point 2 (CAL.POINT 2)*

This item allows to change nominal and calibration value of Calibration point 2. For detail description see Calibration point 1.

#### 5.4.2.4 *Calibration point 3 (CAL.POINT 3)*

This item allows to change nominal and calibration value of Calibration point 3. For detail description see Calibration point 1.

#### 5.4.2.5 *Calibration point 4 (CAL.POINT 4)*

This item allows to change nominal and calibration value of Calibration point 4. For detail description see Calibration point 1.

#### 5.4.2.6 *Original calibration settings (Orig. cal. settings)*

This item restores calibration settings on factory settings (Number of calibrations points, Calibration points 1-4, Range and Low flow cut-off)

### 5.4.3 *General settings (GENERAL)*

This item serves for flowmeter general settings.

#### 5.4.3.1 *Interface parameters (USB-RS232)*

This item allows to change USB (virtual RS232) parameters.

##### 5.4.3.1.1 *Bus mode (Mode)*

Following modes are available:

Normal  
Modbus ASCII  
Modbus RTU

##### 5.4.3.1.2 *Modbus parity (Modbus parity)*

Following parity setting is available:

None  
Even  
Odd

#### 5.4.3.1.3 *Modbus address (Modbus address)*

Available range for modbus addresses is 1 to 247.

### 5.4.3.2 *Display parameters (DISPLAY)*

This item allows to change display parameters.

#### 5.4.3.2.1 *Language (Language)*

This item allows to set the language. You can select one of following items: (Cestina, English).

#### 5.4.3.2.2 *Display contrast (Contrast)*

This item allows to set the display contrast in range 30 to 70 %.

#### 5.4.3.2.3 *Message display time (Message time)*

This item allows to set the message display time. You can select one of following items: (Short, Normal, Long).

### 5.4.3.3 *Real time setting (DATE/TIME)*

This item allows to correct time of internal Real time clock and select required date format.

#### 5.4.3.3.1 *Time setting (Time set)*

This item allows to set the actual time. Range is 00:00 to 23:59.

#### 5.4.3.3.2 *Date setting (Date set)*

This item allows to set the actual date. Range is 01.01.2009 to 31.12.2099.

#### 5.4.3.3.3 *Date format setting (Date format)*

This item allows to set required date format. You can select one of following items: („D/M/Y“, „D.M.Y“, „D-M-Y“, „Y/M/D“, „Y.M.D“, „M/D/Y“, „M-D-Y“).

### 5.4.3.4 *Password setting (USER ACCESS)*

This item allows to set user passwords.

#### 5.4.3.4.1 *Basic access password (Basic password)*

This item allows to set five digits password for access level “BASIC”.

#### 5.4.3.4.2 *Calibration access password (Calibr. password)*

This item allows to set five digits password for access level “CALIBRATION”.

#### 5.4.3.4.3 *Clear on main screen (Clear. on screen)*

This item allows to clear auxiliary volume and min./max. flowrates without password direct from the Main menu. If item is enabled the password is not required.

### 5.4.3.5 *Battery administration (BATTERY)*

This item allows battery administration.

#### 5.4.3.5.1 *Size of battery (Type)*

This item allows to set size of battery pack. You can select one of following types: (2 cells, 4 cells).

#### 5.4.3.5.2 *Change new*

This item use only if you want change battery. After select and confirm (yes) is activate battery replacement.

#### 5.4.3.6 *Service information (INFO)*

This item displays internal measured values. These values can be used for diagnostic.

##### 5.4.3.6.1 *Serial number (Serial number)*

This item displays flowmeter's serial number as 'xxxxxx' (six digits).

##### 5.4.3.6.2 *Firmware version (Version SW)*

This item displays internal firmware version as 'FW x.xx'.

##### 5.4.3.6.3 *Hardware version (Version HW)*

This item displays internal hardware version as 'HW x.xx'.

##### 5.4.3.6.4 *Nominal sensor diameter DN (Diameter)*

This item displays nominal sensor diameter in mm. Diameter can be changed with access level "SERVICE".

##### 5.4.3.6.5 *Internal temperature (Int. temp)*

This item measures internal temperature. Optimal range is -20 to 75 °C.

##### 5.4.3.6.6 *Battery voltage (Volt.battery)*

This item measures battery voltage. Optimal range is 2.8 to 3.7 V.

##### 5.4.3.6.7 *CPU voltage (Volt. CPU)*

This item measures CPU voltage. Optimal range is 2.8 to 3.2 V.

##### 5.4.3.6.8 *Internal voltage +5 V (Volt. high)*

This item measures internal power supply +5 V. Optimal range is 4.7 to 5.1 V.

##### 5.4.3.6.9 *Internal voltage +3.6 V (Volt. +symm)*

This item measures internal power supply +3.6 V. Optimal range is 3.5 to 3.7 V.

##### 5.4.3.6.10 *Internal voltage -3.6 V (Volt. -symm)*

This item measures internal power supply -3.6 V. Optimal range is -3.5 to -3.7 V.

##### 5.4.3.6.11 *Reference voltage +2,5 V (Volt. ref)*

This item measures internal reference. Optimal range is 2.4 to 2.6 V.

##### 5.4.3.6.12 *Coil excitation current(Coil excit)*

This item measures coil excitation current. Optimal range is 22 to 24 mA.

## 5.5 Nominal values (standard factory setting)

### **FLOWMETER**

#### **FLOW**

UNIT	m <sup>3</sup> /h
USER UNIT	l/h
USER CONSTANT	3600
DIRECTION	Positive
EXCIT. TIME	1/15 Hz
L.F.CUTOFF	flowrate $Q_{1\%/2}$
TIME CONSTANT	10s
RANGE	flowrate $Q_n$ (nominal flowrate)

#### **VOLUME**

UNIT	m <sup>3</sup>
USER UNIT	l
USER CONSTANT	1.0

#### **DATALOGGER**

INTERVAL	Off
----------	-----

### **CALIBRATION**

**NUMBER OF CAL.P** 2

#### **CAL. POINT 1**

FLOWRATE	5 ... 10 % of required $Q_n$
CONSTANT	is assigned according to the calibration

#### **CAL. POINT 2**

FLOWRATE	40 ... 70 % of required $Q_n$
CONSTANT	is assigned according to the calibration

#### **CAL. POINT 3**

*Not used*

#### **CAL. POINT 4**

*Not used*

### **GENERAL**

#### **INTERFACE**

USB-RS232	
MODE	Normal
MODBUS PARITY	Even
MODBUS ADDRESS	10

#### **DISPLAY**

LANGUAGE	English
----------	---------

CONTRAST            50 %  
MESSAGE TIME      Normal

**DATE/TIME**

ACTUAL TIME        *actual time (GMT + 1)*  
ACTUAL DATE        *actual date (GMT + 1)*  
DATE FORMAT        D/M/Y

**USER ACCESS**

BASIC PASSWORD    00000  
CAL. PASSWORD     10000  
CLEAR ON SCREEN   Enabled

**INFO**

DIAMETER            *according to the sensor DN*

## 6 System control

Flowmeter can be connected to the computer via USB bus. USB connector is located behind the front panel. RS485 terminals are behind the back panel. In fact, the connected computer creates a virtual serial port RS232 and utilities communicate with the layer RS232. Communication parameters must be set in menu (item USB-RS232).

USB interface can work in three modes:

- a) Normal – communication protocol ADAM compatible with flowmeter M910 and M920.
- b) Modbus RTU – communication protocol Modbus, binary communication.
- c) Modbus ASCII – communication protocol Modbus, ASCII communication.

To transfer data in Normal mode 8N1 data format is used, i.e. each data word includes 8 bits, no parity and one stop bit. The communication speed can be set using the system menu. Available values: 1200, 2400, 4800, 9600 and 19200 Bd. Flowmeter in Modbus mode has its own modbus address. Range of this address is from 1 to 247.

### 6.1 Command syntax

Communication between flowmeter and computer consists of a flow of periodically alternating commands type command-response or query-response. Command is always a text followed by parameter and ended by control sign <cr>. Response is always ended with control sign <cr>.

There are three types of responses:

- 1) Parameters value – response to a query
- 2) Ok – response to a command
- 3) ErrX – in case that command has wrong format. Where X is error code from the table below:

Error code	Meaning
1	Unknown command
2	Parameter out of range
3	Value cannot be set
4	Value cannot be read
5	Unknown parameter
6	Parameter too low
7	Parameter too high

8	Number as parameter is required
9	Access denied – use appropriate password

Modbus protocol is explained in independent chapter.

### Syntax description

<DNPD> = Decimal Numeric Program Data, this format is used to express decimal number with or without the exponent.

<CPD> = Character Program Data. Usually, it represents a group of alternative character parameters. e.g. {0 | 1 | 2 | 3}.

? = A flag indicating a request for the value of the parameter specified by the command. No other parameter than the question mark can be used.

(?) = A flag indicating a request for the parameter specified by the command. This command permits a value to be set as well as requested.

<cr> = carriage return. ASCII code 13. This code executes the command or query.

## 6.2 Command list

### 6.2.1 Main menu

#### *Flowrate reading*

##### **RFL?**

Response contains actual “Flowrate” value in selected units.

##### **Example:**

If query „RFL?<cr>” is sent, flowmeter returns response in format „100.000<cr>“. Resolution is designed by Setup menu.

#### *Volume reading*

##### **RVO?**

Response contains actual “Volume” counter value in selected units.

##### **Example:**

If query „RVO?<cr>” is sent, flowmeter returns response in format „100.000<cr>“. Resolution is designed by Setup menu.

#### *Positive volume reading*

##### **RVP?**

Response contains actual Positive volume counter value.

##### **Example:**

If query „RVP?<cr>” is sent, flowmeter returns response in format „100.000<cr>“. Resolution is designed by Setup menu.

#### *Negative volume reading*

##### **RVN?**



Response contains actual Negative volume counter value.

**Example:**

If query „RVN?<cr>” is sent, flowmeter returns response in format „-100.000<cr>“. Resolution is designed by Setup menu.

*Auxiliary volume reading*

**RVA?**

Response contains actual Auxiliary volume counter value.

**Example:**

If query „RVA?<cr>” is sent, flowmeter returns response in format „100.000<cr>“. Resolution is designed by Setup menu.

## 6.2.2 Flowmeter

### 6.2.2.1 Flowrate parameters

*Flowrate unit*

**FFS(?) <CPD> { 0 | 1 | 2 | 3 | 4 }**

Following units can be set:

- 0 l/s
- 1 m<sup>3</sup>/h
- 2 UG/m
- 3 IG/m
- 4 “User”

M930 confirms execution with string „Ok<cr>”.

**Example:**

Command „FFS 0<cr>” sets flowrate unit “l/s”. If query „FFS?<cr>” is sent, flowmeter returns response in format „0<cr>”.

*Flowrate user unit*

**FFU(?) <CPD>**

Command sets text for flowrate user unit.

<CPD>

It represents user units expressed as 5 ASCII characters. M930 confirms execution with string „Ok<cr>”. In case of query M930 returns set user unit.

**Example:**

Command „FFU l/m <cr>” sets flowrate user unit “ l/m “. After query „FFU?<cr>” flowmeter returns string „l/m <cr>”.

*Conversion constant for flowrate user unit*

**FFC(?) <DNPD>**

Command sets conversion constant for flowrate user unit with respect to [l/s].

<DNPD>

It represents a constant, which is calculated as a ratio between flowrate in user unit and flowrate in basic unit ( [l/s] ). For example constant for [m3/h] is 3.6. M930 confirms execution with string „Ok<cr>”. In case of query M930 returns set constant.

**Example:**

Command „FFC 3.6<cr>” sets constant “3.6 “. After query „FFC?<cr>” flowmeter returns „3.600000<cr>”.

**Flowrate direction****FFD(?) <CPD> { 0 | 1 }**

Following directions can be set:

- 0 Positive
- 1 Negative

M930 confirms direction with string „Ok<cr>”.

**Example:**

Command „FFD 0<cr>” sets “Positive direction”. If query „FFD?<cr>” is sent, flowmeter returns response in format „0<cr>”.

**Low flow cutoff****FLF(?) <DNPD>**

Command sets flowrate limit for suppression low flowrates.

<DNPD>

It represents flowrate expressed in actual unit. All flowrates below this limit are displayed as 0. M930 confirms execution with string „Ok<cr>”. In case of query M930 returns set low flow cut-off.

**Example:**

Command „FLF 0.2<cr>” sets low flow cut-off “0.2“. After query „FLF?<cr>” flowmeter returns „0.200000<cr>”.

**Excitation setting****FEC(?) <CPD> { 0 | 1 | 2 | 3 }**

Following frequencies can be set:

- 0 1 s
- 1 5 s
- 2 15 s
- 3 30 s

M930 confirms execution with string „Ok<cr>”.

**Example:**

Command „FEC 3<cr>” sets excitation 30s. In case of query „FEC?<cr>” flowmeter returns „3<cr>”.

**Time constant****FTC(?) <DNPD>**

Command sets time for moving average calculation.

<DNPD>

It represents time expressed in seconds. Any value in range between 4 second and 20 seconds can be set. M930 confirms execution with string „Ok<cr>”. In case of query M930 returns time constant.

**Example:**

Command „FTC 6<cr>” sets time constant “6” seconds. After query „FLF?<cr>” flowmeter returns „6<cr>”.

**Min. / Max. flowrates Reset****CLRMM**

Command resets “Min. Flowrate” and “Max. Flowrate” values.

M930 confirms execution with string „Ok<cr>”.

**Example:**

Command „CLRMM<cr>” resets both min/max values.

**Nominal flowrate reading****RQN?**

Response contains actual flowmeter's Nominal flowrate ( $Q_N$ ).

**Example:**

If query „RQN?<cr>” is sent, flowmeter returns response in format „80.00<cr>” for nominal flowrate 80 (m<sup>3</sup>/h...).

**6.2.2.2 Volume parameters****Volume unit****FVS(?) <CPD> { 0 | 1 | 2 | 3 | 4 }**

Following units can be set:

- 0 m<sup>3</sup>
- 1 l
- 2 UG
- 3 IG
- 4 “User”

M930 confirms execution with string „Ok<cr>”.

**Example:**

Command „FVS 0<cr>” sets volume unit “m<sup>3</sup>”. If query „FVS?<cr>” is sent, flowmeter returns response in format „0<cr>”.

**Volume user unit****FVU(?) <CPD>**

Command sets text for volume user unit.

<CPD>

It represents user units expressed as 5 ASCII characters. M930 confirms execution with string „Ok<cr>”. In case of query M930 returns set user unit.

**Example:**

Command „FVU dm3 <cr>” sets volume user unit “dm3 “. After query „FVU?<cr>” flowmeter returns string „dm3 <cr>”.

**Conversion constant for volume user unit****FVC(?) <DNPD>**

Command sets conversion constant for volume user unit with respect to [I].

<DNPD>

It represents a constant, which is calculated as a ratio between volume in user unit and volume in basic unit ( [I] ). For example constant for [m3] is 0.001. M930 confirms execution with string „Ok<cr>”. In case of query M930 returns set constant.

**Example:**

Command „FVC 0.001<cr>” sets constant “0.001 “. After query „FVC?<cr>” flowmeter returns „0.001000>”.

**Total volume counter Reset**

**CLRVO**

Command resets “Total volume counter” including the positive and negative volume counter.

M930 confirms execution with string „Ok<cr>”.

**Example:**

Command „CLRVO<cr>” resets the *Total volume counters*.

**Positive and negative volume counter Reset**

**CLRVM**

Command resets “Pos/Neg volume counter” including the positive and negative volume counter.

M930 confirms execution with string „Ok<cr>”.

**Example:**

Command „CLRVM<cr>” resets the *Positive and negative volume counters*.

**Auxiliary volume counter Reset**

**CLRVA**

Command resets “Auxiliary volume counter”.

M930 confirms execution with string „Ok<cr>”.

**Example:**

Command „CLRVA<cr>” resets the *Auxiliary volume counter*.

**6.2.2.3 Datalogger parameters**

**Datalogger step**

**DST(?) <CPD> { 0 | 1 | 2 | 3 | 4 | 5 | 6 | 7 | 8 | 9 }**

Datalogger can be set:

- 0 Datalogger is Off
- 1 Datalogger sampling rate is 5 minutes.
- 2 Datalogger sampling rate is 10 minutes.
- 3 Datalogger sampling rate is 15 minutes.
- 4 Datalogger sampling rate is 30 minutes.
- 5 Datalogger sampling rate is 45 minutes.
- 6 Datalogger sampling rate is 60 minutes.
- 7 Datalogger sampling rate is 120 minutes.
- 8 Datalogger sampling rate is 180 minutes.
- 9 Datalogger sampling rate is 240 minutes.

M930 confirms datalogger step with string „Ok<cr>”.

**Example:**

Command „DST 0<cr>” switches datalogger “Off”. If query „DST?<cr>” is sent, flowmeter returns response in format „0<cr>”.

**Datalogger number of samples**

**DNR?**

Response contains number of flowrate samples stored in datalogger.

**Example:**

If query „DNR?<cr>” is sent, flowmeter returns response in format „252<cr>“ for 252 samples in datalogger.

**Datalogger filling (percentage)**

**DPC?**

Response contains datalogger filling in percent.

**Example:**

If query „DPC?<cr>” is sent, flowmeter returns response in format „14<cr>“ for 14% datalogger full.

**Datalogger filling (bytes)**

**DBT?**

Response contains datalogger filling in bytes.

**Example:**

If query „DBT?<cr>” is sent, flowmeter returns response in format „1850<cr>“ for 1850 bytes used.

**Datalogger reading (text format)**

**DRT?**

Response contains all values stored in internal datalogger.

**Example:**

If query „DRT?<cr>” is sent, flowmeter returns response in format:

```
14:28 13.10.2003      5.82 1/s
14:33 13.10.2003      4.76 1/s
14:38 13.10.2003      4.72 1/s
14:43 13.10.2003      4.72 1/s
14:48 13.10.2003      4.70 1/s
No Record
```

**Datalogger reading (hex format)**

**DRD?**

Response contains all values stored in internal datalogger.

**Example:**

If query „DRD?<cr>” is sent, flowmeter returns response in intel hex format:

**Datalogger clear**

**DCLR**

Command clears all data stored in internal datalogger.

M930 confirms execution with string „Ok<cr>”.

**Example:**

Command „DCLR<cr>” clears all data in datalogger.

### 6.2.3 Calibration

#### *Number of calibration points*

##### **CPN(?) <CPD> { 2 | 3 | 4 }**

M930 confirms completion with string „Ok<cr>”.

##### **Example:**

Command „CPN 2<cr>” sets mode 2 calibration points. If query „CPN?<cr>” is sent, flowmeter returns response in format „2<cr>”.

#### *Nominal value of calibration point 1*

##### **CX1(?) <DNPD>**

Command sets constant CX1, which represents the nominal value of calibration point 1.

<DNPD>

It represents nominal value in selected units. M930 confirms completion with string „Ok<cr>”. In case of a query the M930 returns the set value in the selected unit.

##### **Example:**

Command „CX 110.5<cr>” sets value CX1 to 10.5. After query „CX1?<cr>” flowmeter returns string „10.500000<cr>”.

#### *Nominal value of calibration points 2, 3 and 4*

##### **CX2, CX3, CX4**

For explanation see command CX1.

#### *Calibration constant for calibration point 1*

##### **CY1(?) <DNPD>**

Command sets constant CY1, which represents the calibration constant for calibration point 1.

<DNPD>

It represents the calibration constant. M930 confirms completion with string „Ok<cr>”. In case of a query the M930 returns the set value.

##### **Example:**

Command „CY 110.5<cr>” sets value CY1 to 10.5. After query „CY1?<cr>” flowmeter returns string „10.500000<cr>”.

#### *Calibration constants for calibration points 2, 3 and 4*

##### **CY2, CY3, CY4**

For explanation see command CY1.

### 6.2.4 General

#### 6.2.4.1 Display parameters

##### *Contrast setting*

##### **FDC (?) <CPD> { 0 | 1 | 2 | 3 | 4 }**

Display contrast setting:

- 0 30 %
- 1 40 %
- 2 50 %
- 3 60 %
- 4 70 %

M930 confirms completion with string „Ok<cr>”.

**Example:**

Command „FDC 2<cr>” sets 50%. If query „FDC?<cr>” is sent, flowmeter returns response in format „2<cr>”.

**Message time setting**

**FDM(?) <CPD> { 0 | 1 | 2 }**

You can select one of following items:

- 0 Short
- 1 Normal
- 2 Long

M930 confirms completion with string „Ok<cr>”.

**Example:**

Command „FDM 2<cr>” sets the message time to “Long”. If query „FDM?<cr>” is sent, flowmeter returns response in format „2<cr>”.

**Language setting**

**FLG(?) <CPD> { 0 | 1 }**

You can select one of following items:

- 0 English
- 1 Cestina

M930 confirms completion with string „Ok<cr>”.

**Example:**

Command „FLG 0<cr>” selects language “English”. If query „FLG?<cr>” is sent, flowmeter returns response in format „0<cr>”.

**6.2.4.2 Real time clock setting**

**Time setting**

**FTM(?) <CPD> HH:MM**

Command sets new time for internal Real Time Clock.

<CPD>

It represents new time in format HH:MM:SS. Any value in range between 00:00 and 23:59 can be set. M930 confirms execution with string „Ok<cr>”. In case of query M930 returns real time.

**Example:**

Command „FTM 14:25<cr>” sets new time (2:25 pm). After query „FTM?<cr>” flowmeter returns „14:25<cr>”.



**Date setting****FDT(?) <CPD> DD.MM.YYYY**

Command sets new date for internal Real Time Clock.

<CPD>

It represents new date in format DD.MM.YYYY. Any value in range between 01.01.2000 and 31.12.2099 can be set. M930 confirms execution with string „Ok<cr>”. In case of query M930 returns real date.

**Example:**

Command „FDT 05.03.2002<cr>” sets new date (March 5, 2002). After query „FDT?<cr>” flowmeter returns „05.03.2002<cr>”.

**Date format setting****FDF(?) <CPD> { 0 | 1 | 2 | 3 | 4 | 5 | 6 }**

You can select one of following items:

- 0 M/D/Y
- 1 M-D-Y
- 2 D/M/Y
- 3 D.M.Y
- 4 D-M-Y
- 5 Y/M/D
- 6 Y.M.D

M930 confirms completion with string „Ok<cr>”.

**Example:**

Command „FDF 0<cr>” sets the date format “D/M/Y”. If query „FDF?<cr>” is sent, flowmeter returns response in format „0<cr>”.

**6.2.4.3 Password setting****Password****PSW <DNPD>**

Command enters password, that enables access to flowmeter’s settings. Password can be change with new command PSW.

**Example:**

Command „PSW 12345<cr>” enters password 12345.

**Actual access level****PAL(?) <CPD> { 0 | 1 | 2 | 3 }**

Command can set the access level to 0. Query returns the actual access level.

Available levels:

- 0 Without access
- 1 Basic access level
- 2 Calibration access level
- 3 Service access level

**Example:**

If query „PAL? <cr>” is sent flowmeter returns response in format “2<cr>”, for “Calibration access level”. Command „PAL0<cr>” sets the flowmeter to access level 0 (without access).

**Direct reset from the Main menu****FME(?) <CPD> { 0 | 1 }**

Command enables the possibility to reset Auxiliary volume and Min. / Max. flowrate direct from the Main menu (without password).

One of following states can be set:

- 0 Disabled
- 1 Enabled

M930 confirms completion with string „Ok<cr>”.

**Example:**

Command „FME 1<cr>” enables direct reset from the Main menu. If query „FME?<cr>” is sent, flowmeter returns response in format „1<cr>”.

**Basic access password setting****FPB(?) <DNPD>**

Command changes the password valid for access level “Basic”.

<DNPD>

Presents new password in range 0 to 99999. M930 confirms completion with string „Ok<cr>”.

**Example:**

Command „FPB 520<cr>” sets basic password “520”. If query „FPB?<cr>” is sent, flowmeter returns response in format „520<cr>”.

**Calibration access password setting****FPC(?) <DNPD>**

Command changes the password valid for access level “Calibration”.

<DNPD>

Presents new password in range 0 to 99999. M930 confirms completion with string „Ok<cr>”.

**Example:**

Command „FPC 520<cr>” sets calibration password “520”. If query „FPC?<cr>” is sent, flowmeter returns response in format „520<cr>”.

**6.2.4.4 Service information****Device identification****IDN?****\*IDN?**

Response contains flowmeter’s model type number.

**Example:**

If query „IDN?<cr>” is sent, flowmeter returns response in format „,,,M930-V0000,360001,1.00<cr>”.

**Nominal diameter reading****RDN?**

Response contains actual flowmeter’s Nominal diameter (DN).

**Example:**

If query „RDN?<cr>” is sent, flowmeter returns response in format „,50<cr>” for nominal diameter 50mm.

**Battery's capacity reading (percentage)****BAT?**

Response contains actual battery's capacity.

**Example:**

If query „BAT?<cr>” is sent, flowmeter returns response in format „50<cr>“ for capacity 50%.

**6.2.4.5 Error messages****Errors reading****IER?**

Response contains list of all errors from the power on or from the last reading (query IER?).

The Mask allows selecting which errors will be reported via the State Output. Errors are expressed as sum of bit values of errors. Bit value of possible errors is in the table:

Bit	Bit value	Error
D0	1	Battery voltage overload
D1	2	Internal voltage overload
D2	4	Excitation open
D3	8	Empty pipe
D4	16	Datalogger full
D5	32	Temperature over
D6	64	Flash erasing over

**Example:**

Response „0<cr>” indicates that there was no error. Response “16<cr>“ indicates datalogger full. Value “12<cr>” (8+4) indicates that excitation circuit is open and there is no liquid in the pipe (empty pipe).

**Flowmeter's state reading****RES?**

Response contains flowmeter's state.

Response is:

- 0 - flowmeter measures without correct
- 1 - flowmeter indicates error (in the last 3 seconds before the query was sent)

**Example:**

If query „RES?<cr>” is sent, flowmeter returns response in format „0<cr>“

## 7 Error messages

When any error occurs, the flowmeter will display an error message. Errors can arise because of:

- Incorrect control, i.e. faulty connection to the flowmeter, grounding, etc.,
- Flowmeter failure

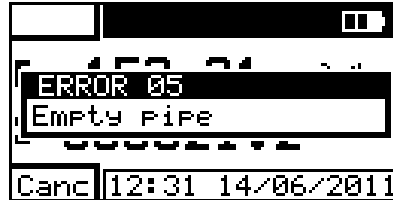

In case of any error, the error message is displayed on the display for approx. 1 to 5 seconds. The same error message can be read by computer (command IER?).

After switching on, an internal test of the hardware is performed. If there were any error during the power on test, the flowmeter displays the appropriate error message.

Types of errors and methods of troubleshooting (if available) are in following table.

Nr	Error	Meaning	Troubleshooting
110	FLASH over	Internal memory error.	Internal error. Turn the flowmeter off and after 5 s turn on. If the error will appear again, contact manufacturer.
120	Temperature error	Ambient temperature error.	
121	Int. voltage	Internal voltage error.	Internal error. Turn the flowmeter off and after 5 s turn on. If the error will appear again, contact manufacturer.
122	Excitation open	Resistance of excitation coils is higher than 250 Ohm.	Resistance of excitation coils is too high (open circuit). Check sensor connection.
125	Empty pipe	No liquid in pipe	Fill the pipe with liquid. In case there is liquid in the pipe, clean electrodes and check connection cables between sensor and electronic.
130	Datalogger full	Memory of datalogger is full.	Read the datalogger using the Flow Assistant software.

Except of errors mentioned above the flowmeter reports also errors caused by incorrect communication with the computer. These errors are described in the chapter „Remote control“.

## 8 Maintenance

The inductive flowmeter is an electronic device with circuits protected with built-in electronic fuses. These protect the instrument against damage caused by the user.

### 8.1 Advice for correct operation

The following principles should be considered during installation:

- *Protect the flowmeter and the internal lining of the sensor pipe from mechanical damage, especially during installation or cleaning.*
- *Protect the flowmeter from direct sunlight. Fit a sunshade if necessary.*
- *Do not expose the flowmeter to intense vibration.*

### 8.2 Periodical maintenance

The flowmeter does not require any special maintenance. Dependent on the media being measured it is recommended that approx. once a year, remove the sensor from the pipe and clean the liner. Method of cleaning consists of removing mechanical dirt and any non-conductive coating (like oil film) from the liner. A very dirty liner could cause inaccuracy of the measurement. Check mechanical state of the liner.

### 8.3 What to do in case of failure

If an **obvious failure** occurs during the operation (e.g. the display is not lit), the flowmeter must be switched off immediately.

- Remove the cover from the transmitter
- Disconnect the power supply battery (see chapter Battery connection)
- Connect power supply again.
- Replace the cover.

If an obvious fault is evident, e.g. a measurement range or an operating mode is not functional, the user cannot correct the fault.

**Hidden faults** can cause different symptoms. Usually, they cause instability of some parameters. Hidden defects can be caused by unacceptable distortion, degraded insulation etc. In this case contact Distributor.

The flowmeter can have “hidden defects”, when correct operation rules are not applied. In this case, the fault can be caused by wrong installation. Most frequent cases of false “hidden defects”:

- mains voltage out of tolerance limits or unstable
- poor grounding of the measuring circuit (bad connection of the ground terminal )

large electrostatic or electromagnetic field.

## 9 Application information

### 9.1 Weight and dimensions

Flowmeter weight and dimensions depend mostly on the version (remote or compact) and diameter of the pipe.

#### 9.1.1 Electronic unit – compact version

The pictures below show dimensions of the electronic unit for the compact version. Dimensions are in millimetres.

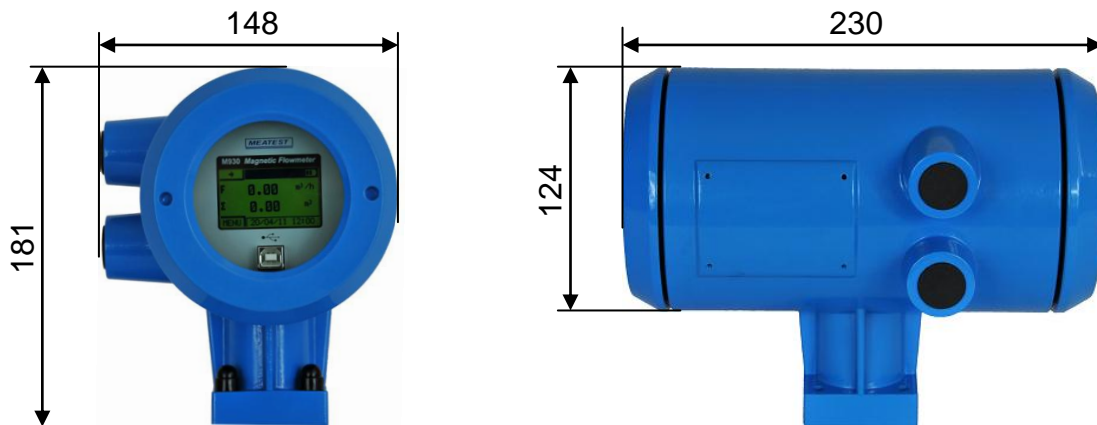

Weight: 3.8 kg

#### 9.1.2 Electronic unit – remote version

The picture shows dimensions of the electronic unit for the remote version. Dimensions are in millimetres.

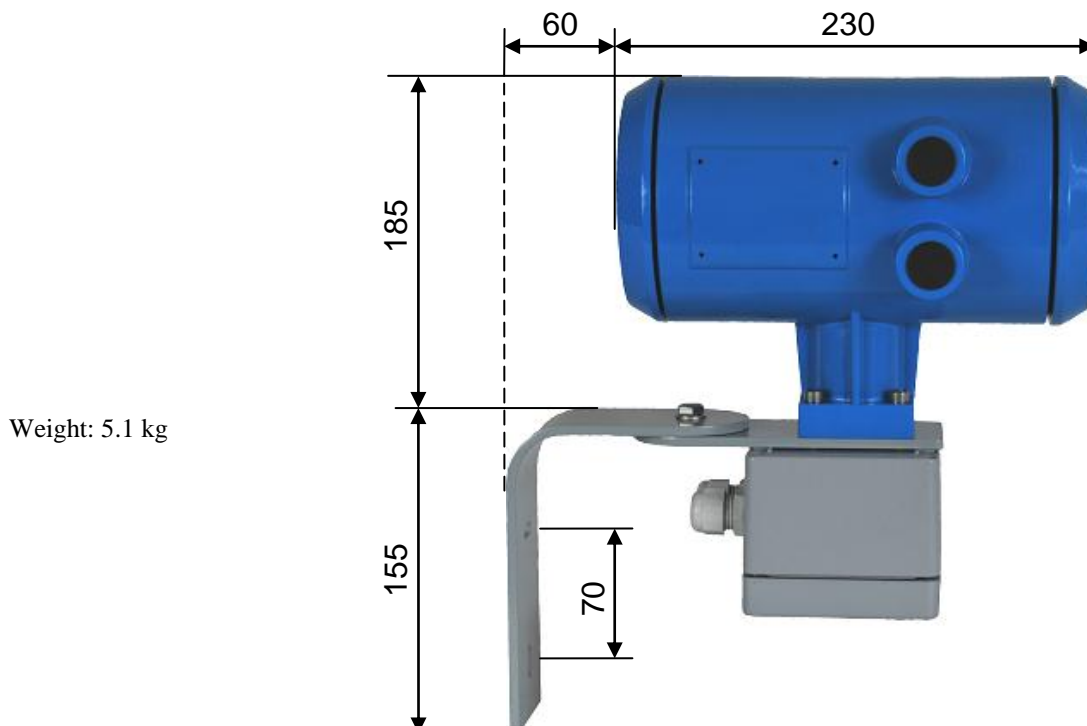

Weight: 5.1 kg

### 9.1.3 Sensor

In the table below are the dimensions of the sensor for compact version. In case of remote version add 120 millimetres to dimension "A" for cable gland and cable. Flanges in DIN version meet standard EN1092. Flanges in ANSI version meet requirements of ANSI B 16.5 standard.

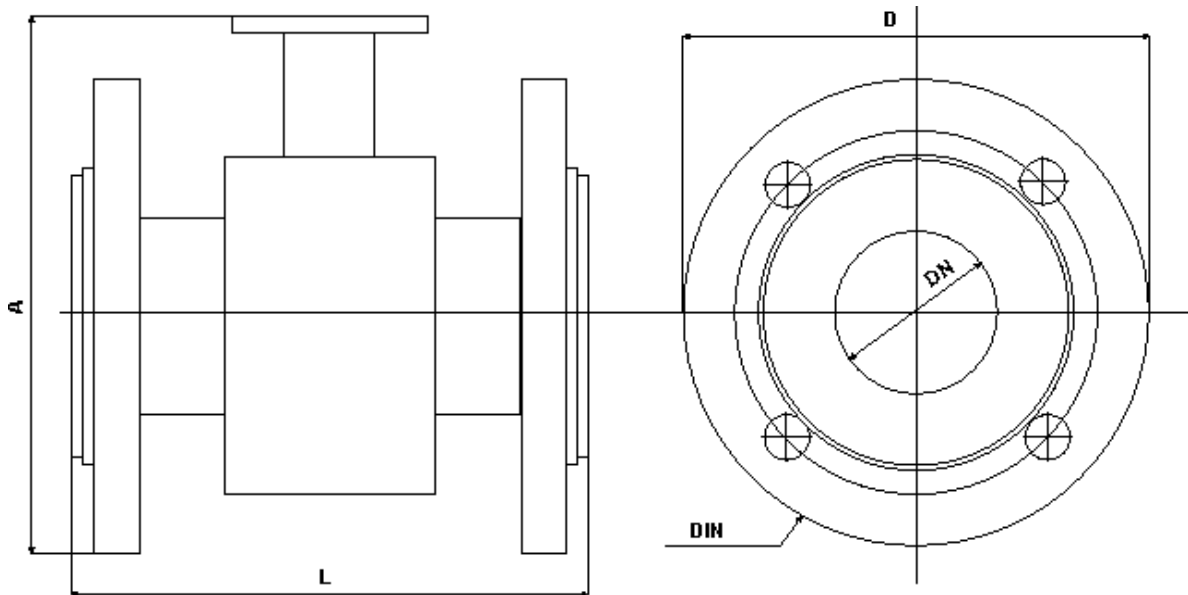

DN (mm)	PN (bar)	D (mm)	A (mm)	L (mm)	Weight (kg)
10	16	90	140	150	2,5
15	16	95	145	200	3
20	16	105	150	200	3,5
25	16	115	155	200	4
32	16	140	165	200	5
40	16	150	175	200	5
50	16	165	185	200	7
65	16	185	200	200	8,5
80	16	200	215	200	10
100	16	220	235	250	13
125	16	250	265	250	17
150	16	285	295	300	22
200	16	340	355	350	31
250	10	395	435	450	44

**Table 1: M930 dimensions and weights – DIN flanges**

## 9.2 Used materials

Electromagnetic flowmeter is made from materials, which meet international standards and conventions.

<b>Liner:</b>	Hard rubber Teflon - PTFE	as standard
<b>Electrodes</b>	CrNi (stainless) steel 1.4571 Hastelloy C276 Tantalum	as standard
<b>Sensor tube</b>	Stainless steel 1.4201,	dimensions according to DIN 17457
<b>Flange</b>	Steel 1.0402 or higher,	dimensions according to EN1092, DIN2501(=BS 4504), ANSI B16.5, Sanitary DIN11851, flangeless wafer style



### 9.3 Flowrate versus diameter

The choice of flowrate for an electromagnetic flowmeter depends on the diameter of the sensor. The higher pipe diameter, the higher flowrate can be measured. A determining parameter for flowrates is maximum velocity of the liquid. Maximum velocity is the speed, where the flow of liquid inside pipe is still laminar. In M930 it is limited to 10m/s (with 125% overload). Speed over 10 m/s is usually too high for industrial applications. Such diameter of pipe is usually selected, where expected flowrate is between  $Q_{5\%}$  and  $Q_{50\%}$ .

In the table bellow applicable flowrates for various diameters is displayed in units l/s and m<sup>3</sup>/hr.

DN	Flowrates [ l/s ]						Flowrates [ m3/h ]					
	$Q_{1\%}$	$Q_{5\%}$	$Q_N$	$Q_{50\%}$	$Q_{100\%}$	$Q_{MAX}$	$Q_{1\%}$	$Q_{5\%}$	$Q_N$	$Q_{50\%}$	$Q_{100\%}$	$Q_{MAX}$
10	0,01	0,04	0,20	0,39	0,79	0,98	0,03	0,14	0,80	1,41	2,83	3,53
15	0,02	0,09	0,50	0,88	1,77	2,21	0,06	0,32	2,00	3,18	6,36	7,95
20	0,03	0,16	0,90	1,57	3,14	3,93	0,11	0,57	3,20	5,65	11,31	14,14
25	0,05	0,25	1,40	2,45	4,91	6,14	0,18	0,88	5,00	8,84	17,67	22,09
32	0,08	0,40	2,20	4,02	8,04	10,05	0,3	1,5	8,00	14,5	29,0	36,2
40	0,1	0,6	4,0	6,3	12,6	15,7	0,5	2,3	13,0	22,6	45,2	56,6
50	0,2	1,0	6,0	9,8	19,6	24,5	0,7	3,5	20,0	35,3	70,7	88,4
65	0,3	1,7	9,0	16,6	33,2	41,5	1,2	6,0	35,0	59,7	119,5	149,3
80	0,5	2,5	14,0	25,1	50,3	62,8	1,8	9,0	50,0	90,5	181,0	226,2
100	0,8	3,9	20,0	39,3	78,5	98,2	3	14	80	141	283	353
125	1	6	30,0	61	123	153	4	22	150	221	442	552
150	2	9	50,0	88	177	221	6	32	200	318	636	795
200	3	16	100	157	314	393	11	57	300	565	1131	1414
250	5	25	150	245	491	614	18	88	500	884	1767	2209

$Q_{1\%}$  - minimum applicable flowrate (minimum flowrate with guaranteed accuracy)

$Q_{5\%}$  - recommended minimum flowrate (minimum flowrate with best accuracy)

$Q_N$  - recommended nominal flowrate (expected working flowrate)

$Q_{50\%}$  - recommended maximum flowrate (maximum flowrate for industrial use)

$Q_{100\%}$  - maximum applicable flowrate (maximum flowrate with guaranteed accuracy)

$Q_{MAX}$  - maximum applicable overload ( $Q_{125\%}$ ) (flowmeter is still measuring)

**Table 2: M930 flowrates**

A sensor diameter should be chosen to keep real flowrate between  $Q_{5\%}$  and  $Q_{50\%}$ , because in this range the flowmeter has the best accuracy.

## 10 Type plate

### Compact version

The type plate is located on the sensor. The following information is on the plate:

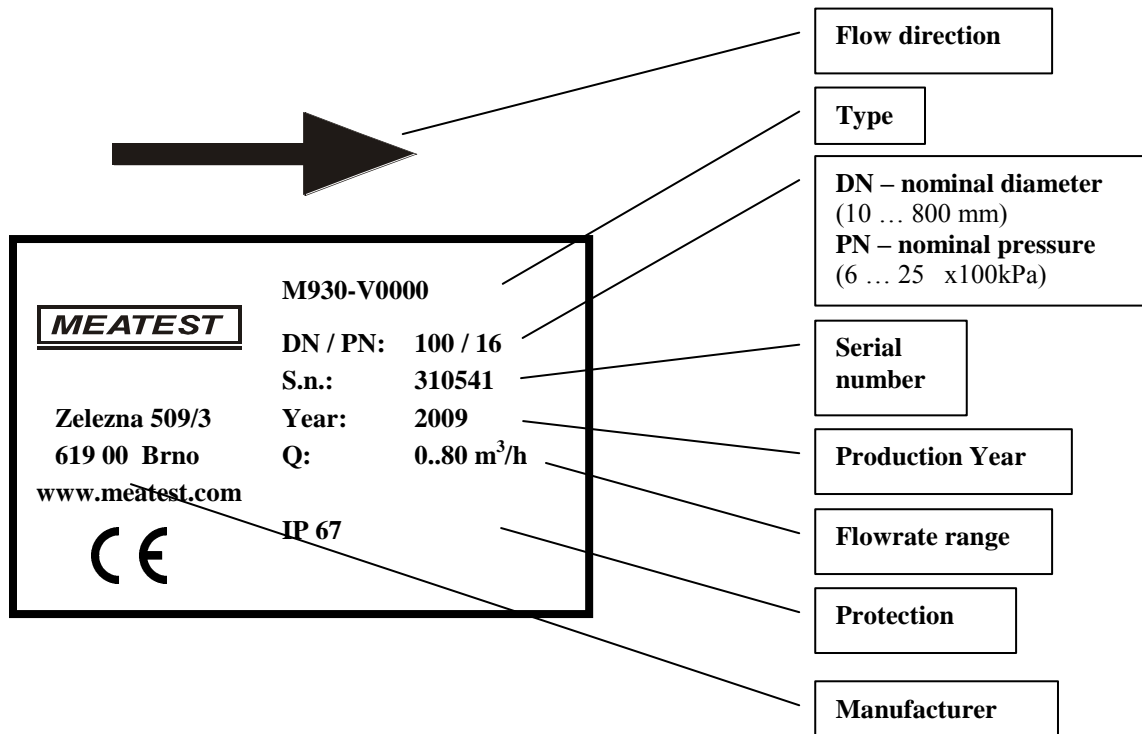

**Remote version**

Type plate on the **flanged sensor**:

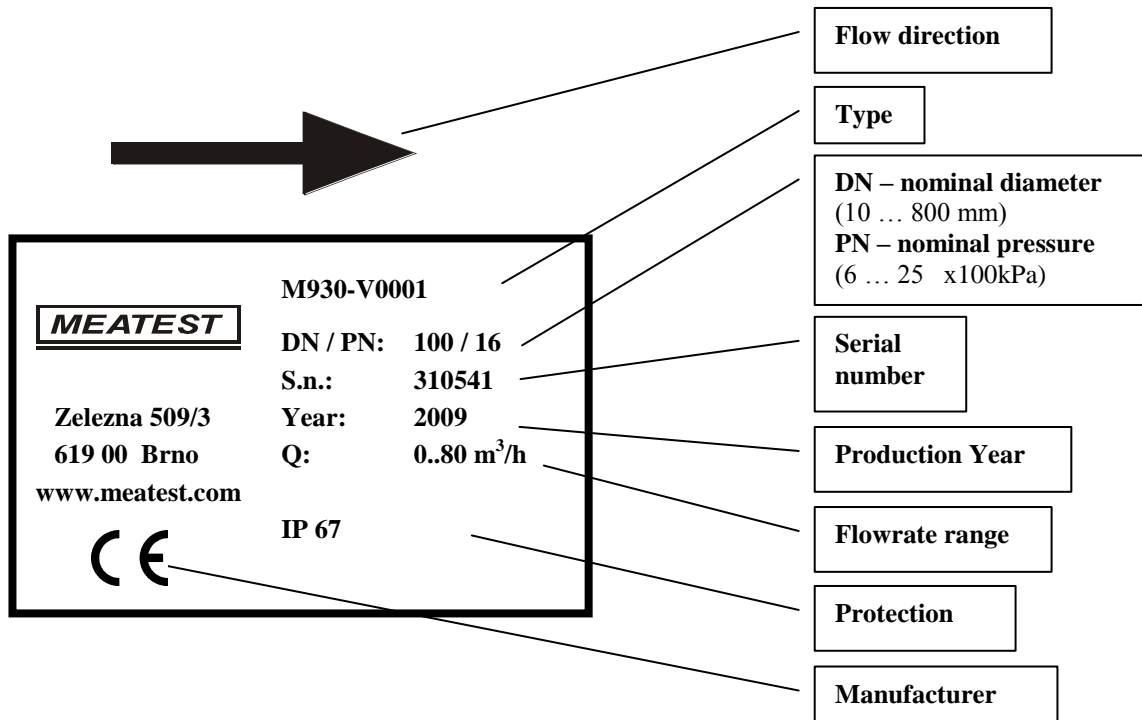

Type plate on the **converter**:

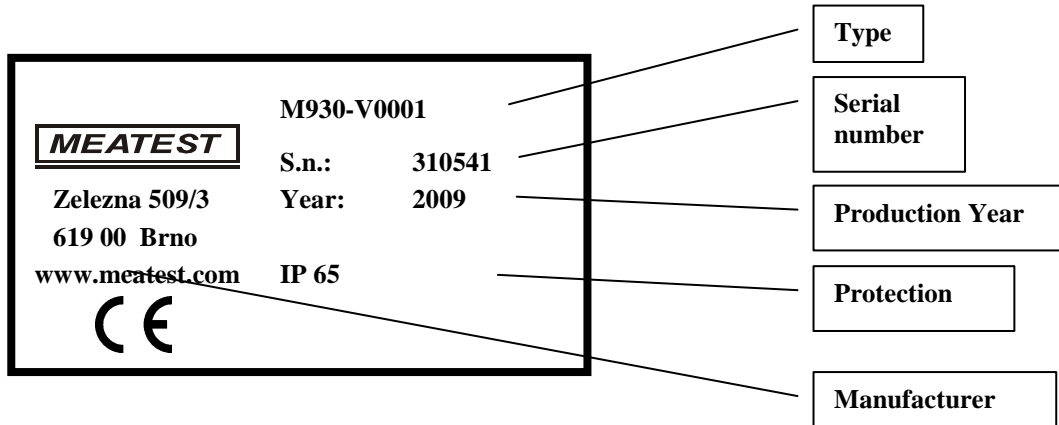

## 11 Technical data

Nominal size	DN10 to DN250
Nominal pressure	PN10 to PN40 (depending on nominal size)
Flow range	0.1 to 12 m/s (0.01 to 600 l/s) / (0.03 to 2100 m <sup>3</sup> /h)
Accuracy	<ul style="list-style-type: none"> <li>• 0.5 % (0.5 to 12 m/s) of reading value</li> <li>• 1 % (0.1 to 0.5 m/s)</li> </ul>
Maximum media temperature	0 to 80°C (32 to 176°F) for rubber liner 0 to 150°C (32 to 302°F) for PTFE liner in remote version
Minimum electrical conductivity	≥ 5 μS / cm
Ambient temperature	-20 to 60 °C (-4 to 140°F)
Excitation coils temperature	-20 to 150 °C (-4 to 302°F)
Power supply	Internal battery
Liner	<ul style="list-style-type: none"> <li>• hard rubber</li> <li>• soft rubber</li> <li>• PTFE</li> </ul>
Electrodes	<ul style="list-style-type: none"> <li>• CrNi (stainless) steel 1.4571</li> <li>• Hastelloy C276</li> <li>• Tantalum</li> </ul>
Measuring tube	Stainless steel 1.4201, dimensions according to DIN 17457
Flange	Steel 1.0402 or higher Dimensions according to EN1092, DIN2501 (BS 4504), ANSI B16.5, Sanitary DIN11851, flangeless wafer style
Protection category	<ul style="list-style-type: none"> <li>• Compact version: IP67</li> <li>• Remote version: sensor IP68, converter IP65- optionally IP67</li> </ul>
Communication	<ul style="list-style-type: none"> <li>• USB (Modbus)</li> </ul>
Displayed values	<ul style="list-style-type: none"> <li>• Flowrate (m<sup>3</sup>/h, l/s, US.Gal/min, Imperial.Gal/min, user)</li> <li>• Volume (m<sup>3</sup>, l, US.Gal, Imperial.Gal, user)</li> <li>• Positive, total, negative and auxiliary (clearable, daily) volume</li> </ul>
Control	<ul style="list-style-type: none"> <li>• Capacitive buttons</li> <li>• USB</li> </ul>
Other features	<ul style="list-style-type: none"> <li>• Test of: excitation coils, sensor, electronic unit</li> <li>• Internal temperature and power supply diagnostic</li> <li>• Real time clock</li> <li>• Empty pipe indication</li> <li>• Datalogger 100000 records (programmable sample rate)</li> <li>• Registration of min. and max. flowrate including date and time</li> </ul>

## 12 Ordering information - options

### Liner

M930-V0xxx	hard rubber
M930-V1xxx	soft rubber
M930-V2xxx	teflon PTFE

### Electrodes

M930-Vx0xx	CrNi steel
M930-Vx1xx	hastelloy C276
M930-Vx2xx	tantalum

### Construction

M930-Vxxx0	compact version
M930-Vxxx1	remote version

### 12.1 Example of order

#### M930-V0000 DN50 PN16

Liner: hard rubber  
Electrodes: CrNi steel  
Construction: compact version  
Nominal diameter: 50 mm  
Nominal pressure: 16 bar

#### M930-V2120 DN15 PN25

Liner: PTFE  
Electrodes: hastelloy C276  
Construction: compact version  
Nominal diameter: 15 mm  
Nominal pressure: 25 bar

## 13 Terminology

Special symbols and terms.

### Flowrates:

- Q<sub>1%</sub>** - minimum applicable flowrate (the least flowrate which has guaranteed measuring accuracy – depends on diameter – see table 2 M930 flowrates).
- Q<sub>5%</sub>** - recommended minimum flowrate (least flowrate which has the best measuring accuracy – depends on diameter – see table 2 M930 flowrates).
- Q<sub>N</sub>** - recommended nominal flowrate (nominal flowrate in which is flowmeter usually calibrated – depends on diameter – see table 2 M930 flowrates). You can predetermine this nominal flowrate in your order.
- Q<sub>50%</sub>** - recommended maximum flowrate (maximum flowrate which is usually used in industrial applications – depends on diameter – see table 2 M930 flowrates).
- Q<sub>100%</sub>** - maximum applicable flowrate (flowrate limit which has guaranteed measuring accuracy – depends on diameter – see table 2 M930 flowrates).
- Q<sub>MAX</sub>** - maximum applicable overload (**Q<sub>125%</sub>**) (maximum flowrate which can be still measured – depends on diameter – see table 2 M930 flowrates).

### Abbreviations:

- QP** - impulse output constant. It represents volume for 1 impulse.
- PF1** - flowrate limit constant. It represents low limit flowrate. Crossing this limit activates the appropriate digital output.
- PF2** - flowrate limit constant. It represents high limit flowrate. Crossing this limit activates the appropriate digital output.
- H** - flowrate limit constant. It represents hysteresis by evaluating limits PF1 and PF2.

**Auxiliary volume counter** – second Total Volume counter. Can be cleared by pushing “→” key. It is usually used for measuring volume during day, month etc.

**USB** – universal serial bus. It enables remote control of instruments by a computer.

## Appendix A Measuring principle

The flowmeter is designed for electrically conductive fluids. Measurement is based on Faraday's law of induction, according to which a voltage is induced in an electrically conductive body, which passes through a magnetic field. The following expression is applicable to the voltage:

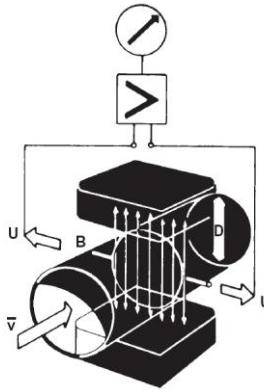

$$U = K \times B \times v \times D$$

where:

- U = induced voltage
- K = an instrument constant
- B = magnetic field strength
- v = mean velocity
- D = pipe diameter

Thus the induced voltage is proportional to the mean flow velocity, when the field strength is constant. Inside the electromagnetic flowmeter, the fluid passes through a magnetic field applied perpendicular to the direction of flow. An electric voltage is induced by the movement of the fluid (which must have a minimum electrical conductivity). This is proportional to the mean flow velocity and thus to the volume of flow. The induced voltage signal is picked up by two electrodes, which are in conductive contact with the fluid and transmitted to a signal converter for a standardized output signal. This method of measurement offers the following advantages:

- No pressure loss through pipe constriction or protruding parts.
- Since the magnetic field passes through the entire flow area, the signal represents a mean value over the pipe cross-section; therefore, only relatively short straight inlet pipes  $\times$  DN from the electrode axis are required upstream of the primary head.
- Only the tube liner and the electrodes are in contact with the fluid.
- Already the original signal produced is an electrical voltage, which is an exact linear function of the mean flow velocity.
- Measurement is independent of the flow profile and other properties of the fluid.

The magnetic field of the primary head is generated by a square wave current fed from the signal converter to the field coils. This field current alternates between positive and negative values. Alternate positive and negative flowrate-proportional signal voltages are generated at the same frequency by the effect of the magnetic field, which is proportional to the current. The positive and negative voltages at the primary head electrodes are subtracted from one another in the signal converter. Subtraction always takes place when the field current has reached its stationary value, so that constant interference voltages or external or fault voltages changing slowly in relation to the measuring cycle are suppressed. Power line interference voltages coupled in the primary head or in the connecting cables are similarly suppressed.

## Appendix B M930 Menu structure

M930 has three access levels for parameter's setting:

- **Basic (user access)**
- **Calibration (calibration laboratory)**
- **Service (service organization)**

Every parameter has minimal access level which allows you to change it.

Access to parameters is enabled after pushing the key "ENTER" from the *Main menu* and after entering the password. Access level is defined by used password.

**Setup menu** has following folders:

- FLOWMETER
- CALIBRATION
- GENERAL
- SERVICE

<b>FLOWMETER</b>	FLOW	Unit	
		User unit	
		User constant	
		Direction	
		Low-fl. off	
		Exc. freq	
		Time const.	
		Range	
	VOLUME	Unit	
		User unit	
		User Constant	
		CLEAR VOLUME	
			Auxiliary volume
			Total volume
			Pos/Neg volume
	DATALOGGER	Interval	
		Filling	
		Clear	
<b>CALIBRATION</b>	Num.of cal.point		
	CAL. POINT 1	Flowrate	
		Constant	
	CAL. POINT 2	Flowrate	
		Constant	
	CAL. POINT 3	Flowrate	
		Constant	
	CAL. POINT 4	Flowrate	
		Constant	
		Orig. cal. settings	
<b>GENERAL</b>	USB-RS232	Mode	
		Modbus parity	
		Modbus address	
	DISPLAY	Language	
		Contrast	
		Message time	
	DATE/TIME	Time set	
		Date set	
		Date format	
	USER ACCESS	Basic password	
		Calibr. password	
		Clear. on screen	



	INFO	Serial number	
		Version SW	
		Version HW	
		Diameter	
		Int. temp	
		Volt. battery	
		Volt. CPU	
		Volt high	
		Volt. +symm	
		Volt. -symm	
		Vol. ref	
		Coil excit	
<b>SERVICE</b>			

### **Manufacturer**

MEATEST, spol.s r.o.  
 Zelezná 509/3, 619 00 Brno  
 Czech Republic  
 www.meatest.com

tel: +420 – 543 250 886  
 fax: +420 – 543 250 890  
 meatest@meatest.cz