

## 1. DESCRIPTION

1.1. These electropumps have been designed to recirculate lightly treated water in private and public swimming pools.

### 1.2. Technical characteristics

#### MOTOR:

**Power rating:** See motor plate.

**Insulation:** Class F.

**Operation:** Continuous.

**Protection:** IP 55.

**Current:** Triphase (see nameplate ratings).

**Consumption:** See motor plate.

**Frequency:** See motor plate.

**R.P.M.:** See motor plate.

**Shaft:** Stainless steel.

**Bearing:** Amoured ball bearing.

**Atmospheric temperature:** Minimum 1°C - Maximum 40°C.

#### PUMP:

**Water temperature:**

Minimum 1°C - Maximum 40°C.

**Maximum pressure:** 2,1 bar.

**Impeller model:** Closed.

**Type of seal:** Mechanical.

**Impeller:** Type FD

**Pump casing:** Type FD

**Prefilter:** Type FD

**Basket:** Stainless Steel.

**Suction diameter:** According to the pump characteristics.

**Delivery diameter:** According to the pump characteristics.

## 2. GENERAL

2.1. **Introduction.** This Handbook contains the instructions necessary for installation, use and maintenance of the swimming pool electropump. In order to obtain the maximum performance shown in the Description of Characteristics, it is necessary to fulfil and follow correctly all the recommendations given in this Handbook. This will allow operation with a safe and long-lasting piece of equipment.

The equipment supplier will furnish the user with complementary information, if required.

### 2.2. Safety signs used in the handbook

All instructions referring to possible risks to persons are highlighted by the following symbols:

Danger  
in general



Danger  
of  
electrocution

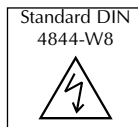



Other instructions in relation to the functioning of the equipment with which non-compliance could cause physical damages are highlighted with the warning: **ATTENTION**

2.3. **Nameplate ratings (EEC 89/392 P.1.7.4.A).** The information given on the nameplate or other instructions affixed to the unit, must be strictly complied with. The content of these plates can usually be found in this Handbook (Chapter 1.2.).

2.4. **Liability.** Failure to comply with the instructions given by BOMBAS PSH in this Handbook, in relation to the choice, handling, installation, starting and maintenance of the unit, shall release the manufacturer or distributor from all liability in respect of accidents suffered by persons or damages caused to other installations and, in addition, shall entail forfeit of the warranty.

2.5. **Standards.** Our swimming pool electropumps are manufactured in accordance with the necessary requirements for safety and health set forth in Community Directives 89/392/EEC, 91/368/EEC (assimilated into Spanish Law by Royal Decrees 1435/1992 and 93/44/EEC).

 3.1. Safety during operation of the machinery supplied can only be guaranteed if it is used in accordance with the diagrams show "Illustrations". It must never exceed the working conditions and limits given in this Handbook (Chapter 1.2. - Technical Characteristics). Compliance with the provisions of Safety Standards in force in each country is mandatory.

 3.2. Please ensure that the equipment selected is adequate for the used for which it is intended and that its condition, installation, starting and subsequent use are correct. See chapter 1.2. (Technical Characteristics).

 3.3. Installation, repair and maintenance operations will be carried out in all cases with the equipment disconnected from the mains.

 3.4. While the equipment is functioning, it cannot be moved or repositioned. These operations will be carried out at all times with the machine disconnected.

 3.5. Pressing of the electrical on/off or safety elements will not be performed where there is damp, and special care must be taken for user's hands to be dry, and also with footwear and surfaces with which the user is in contact.

 3.6. Those elements of the equipment which, when functioning, are in movement or which could reach dangerous temperatures, will be protected with cages or casings which will prevent accidental contact with the same.

 3.7. Electricity conductors, or parts which could carry current, will be suitably insulated. Other metal parts of the equipment will be correctly earthed.

 3.8. Spare parts that may be necessary will be originals from the manufacturer or those recommended by the manufacturer. The use of others, are not permitted and **release** the manufacturer or distributor from all liability.

## 4. PACKING, TRANSPORT AND STORAGE

### 4.1. ATTENTION.

The manufacturer supplies the equipment protected in suitable packaging, so that it is not damaged during transport or storage thus ensuring its correct installation and/or functioning.

### 4.2. ATTENTION.

The user, upon receipt of the equipment, will immediately check the following points:

- Condition of the outside packaging, if this shows signs of serious deterioration, he shall formally advise the person delivering the equipment.
- He shall also check the condition of the contents; should this show defects which would presumably prevent correct functioning, he shall also formally notify the supplier within a period not exceeding 8 days from the date of delivery.

### 4.3. ATTENTION

Storage conditions must ensure the optimum preservation of the equipment. Due to its particular relevance, we must stress that very damp atmospheres or others where extreme changes in temperatures (which cause condensation) must be avoided.

## 5. INSTALLATION AND ASSEMBLY

### 5.1. Location. ATTENTION.

The place where the electropump is to be located must be dry. In all events, there must be a drain in the floor as a prevention against flooding. If the pump is to be located in a damp place, a ventilation system must be provided in order to prevent the formation of condensation.

In the case of very confined areas, cold air can reach a low temperature which requires a ventilation system where by the it does not exceed 40°C. It is important for there to be sufficient space to permit the motor block to be dismounted horizontally and the hair filter vertically (see minimum space diagram in fig. 1).

### 5.2. Positions / Installation

#### ATTENTION

The equipment or set of motor pump, filter and selection valve, will be installed near the swimming pool at a distance of no more than 3 m, from the surface skimmers and preferably at a level of 0,5m (never more than 3m) below the level of the water, in order to achieve its "under load" functioning. The selection valve junction, and its connection to the nozzle and other accessories incorporated in the swimming pool will preferably be made in PVC pipe. Pipe diameters will depend on flows. The maximum water speed advisable in the pipes will be 1.2 m/s in suction and 2m/s in impulsion. In any event, the diameter of the suction pipe must not be less than the diameter of the pump nozzle.

The suction pipe must be perfectly watertight and must be installed with a downward inclination, thus avoiding the formation of air pockets. In permanent installations, with the pump positioned at a higher level than that of the water, it is advisable for the longest stretch of the suction pipe to be below the levels mentioned until it reaches the vertical pipe which coincides with the pump suction line.

The suction pipe can be either rigid or flexible with a reinforced coil to avoid contraction. In fixed installations, with the pump below the water level, a shut-off valve will be placed on the suction pipe and another on the header pipe.

### 5.3. Connection to the mains

#### ATTENTION

  ● In general terms, the electrical installation will fully comply with the Regulations and Complementary Technical provisions applicable and will be performed by an authorised Installer.

- The supply will have neutral and earth wires.
- The mains voltage must correspond to that shown on the nameplate rating for the equipment.
- The earth wire to be used must be sufficient to take, without deterioration, the current absorbed by the equipment (see nameplate).
- The mains earth wire will be connected electrically to all metal parts of the equipment which should not be under current, but which could accidentally be affected by the same and which are accessible to persons (see figs. 2).

It is obligatory to install a protection and operation switchboard which will contain all necessary and recommended elements. In general terms, it will contain:

- General cut-off or unipolar switch.
- Short-circuit and overload protection devices for motors.
- 30mA differential high sensitivity switch.
- Others for monitoring and control.

The electrical characteristics of the protection devices and their regulation will comply with those for the motors to be protected and with the service conditions envisaged for these, and the instructions given by the manufacturer must be followed (see nameplate).

- In the case of equipment with triphase motors, the motor winding interconnection bridges, must be suitably positioned (see figs. 2).
- Conductor inlets and outlets at the bushing box will have stuffings to ensure the absence of damp and dirt, and will therefore have a sealed casing.
- Conductors will have suitable terminals for connection to the bushings.



#### 6. STARTING

Before connecting the equipment to the mains, the following operations will be carried out:

- Check that the electrical conditions are correct.
- Manually check that the motor pump is not jammed.

**6.1. Pump priming. ATTENTION.** "Avoid blind functioning of the electro-pump". With the pump in the suction position (above the water level of the swimming pool), before starting, remove the prefilter cover (66) (fig. 3) and slowly fill with clean water up to the level of the aspiration nozzle. Close the cover (66) again and take care that it is hermetically closed.



**ATTENTION.** With the pump below the swimming pool water level, always with the cover (66) hermetically closed, fill the pump by slowly opening the aspiration cut-off valve, with the header valve in the open position.

**6.2. ATTENTION.** The pump must not be started without the lumps and hair filter (item 64) (fig. 3) since this could cause obstruction and would block the system.

**6.3. Direction of rotation. ATTENTION.** Ensure that the motor shaft turns freely; do not start the pump if it is blocked. For this purpose, electropumps have a groove at the end of the shaft, on the ventilator side, which permits it to be turned manually using a screwdriver (fig. 1).

In triphase motors, the impeller (55) can be unscrewed if the motors starts in the opposite direction.

Counter-rotation can even damage the mechanical seal. Start the motor for a few seconds and check that the direction of rotation coincides with that indicated by the arrow on the ventilator cover.

Should this not be the case, it is absolutely necessary to advise the authorised installer (invert the connections between two phases).

#### 6.4. ATTENTION.

Check that the motor does not exceed the amperage indicated on the nameplate rating (120) (fig. 3); otherwise, regulate using the header valve.



#### 7. MAINTENANCE / CONSERVATION

Before touching, disconnect the electricity supply.

**7.1. ATTENTION.** Regularly check and clean the basket (64).

To remove the basket, place the valves, and all other valves, in the "off" position. Loosen the cover (66) of the prefilter (100), remove the basket (64) and clean it under running water, "do not strike" to avoid its deterioration. To re-place the basket (64), introduce it gently, until it is in its original position. Correctly place the joint (65) of the cover (66) and grease with vaseline.

Do not place the basket (64) in chemicals. Please remember that changes in position of the valves will be made at all times with the motor switched off.

#### 7.2. ATTENTION

If the pump is switched off for long periods of time, should there be a danger of frost, the pump casing (62) should be emptied, by loosening the plug (69)/(103) along with their O-ring seals. Before starting the pump, replace the plug (69)/(103) and their O-ring seals. Fill the prefilter (100) with water and check with a screwdriver that the motor is not jammed. If the shaft has seized up, call a qualified technician. In the event of the motor flooding, do not try to start it; call an electrician to dismount the motor in order to dry it.

#### 8. DISMOUNTING

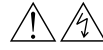

##### 8.1. ATTENTION

Before performing any operation, all valves must be in the "off" position: having checked this:

- Disconnect the general electricity switch and the differential switch (this must be done by an authorised specialist).
- Loosen and remove the supply cables on the connection box (26) (fig. 3).
- Release the aspiration and impulsion sleeves.
- Empty the pump.

##### 8.2. ATTENTION

In order to dismount and assemble the electropump, please see the detail drawing. (Fig. 3). In order to remove the motor from the hydraulic casing (62), remove the four screws (45)(39)(52) and lever so as to separate one part from the other one.

In order to dismount the impeller (55) hold the motor shaft (1) with the aid of a clamp, while rotating the nut (57) to the left (anticlockwise) for models FD17, FD 18, FD 19, FD 20, FD 21, and FD 22, and to the right (clockwise) for models FD 14, FD 15 and FD 16, with a wrench, thus releasing the impeller (55). In this way the mechanical seal (74) is released, too.

#### 9. ASSEMBLY

##### ATTENTION

"All parts to be assembly must be clean and in perfect condition for use".

In order to assemble the pump:

- Assemble the mechanical seal (80). Press this (43) until it locates into the space; the seal will have been lubricated with water beforehand.
- Assemble the impeller (55) on the shaft (1), affixing it with the key (57), impeller washer (56) and impeller nut (57). In this way, the two halves of the mechanical seal are joined.
- Fix the motor to the pump casing (62) by means means of the four screws (63), impeller washer (56) and pump housing nut (107).

#### 10. SPARE PARTS

To order any spare parts, indication must be given of the part, number shown on the detail drawing (fig 3) and nameplate ratings (120).

#### WARNING:

**ALL THE ADJUSTEMENTS THAT ARE MADE TO THE EQUIPMENT MUST BE MADE BY THE AUTHORIZED TECNICAL SERVICE. IF NOT THE GUARANTEE IS VOID AND WE ACCEPT RESPONSABILITY.**

**IF THE EQUIPEMENT IS USED FOR ANY OTHER MEANS THAN SPECIFIED BY THE MANUFACTURED, THE PROTECTION OF THE EQUIPMENT COULD FAIL, THEREFORE LOSING THE COVER OF GUARANTEE.**

**MOD. FD-3.000 r.p.m.**  
**ILUSTRACIONES - ILLUSTRATIONS - ILLUSTRATIONS - ILLUSTRAZIONI**

**Fig. 1**

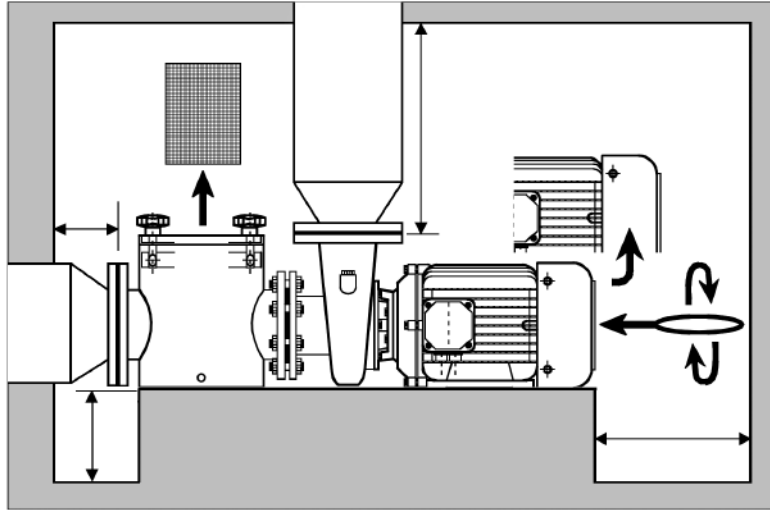

**Fig. 2**

**T R I F A S I C O**

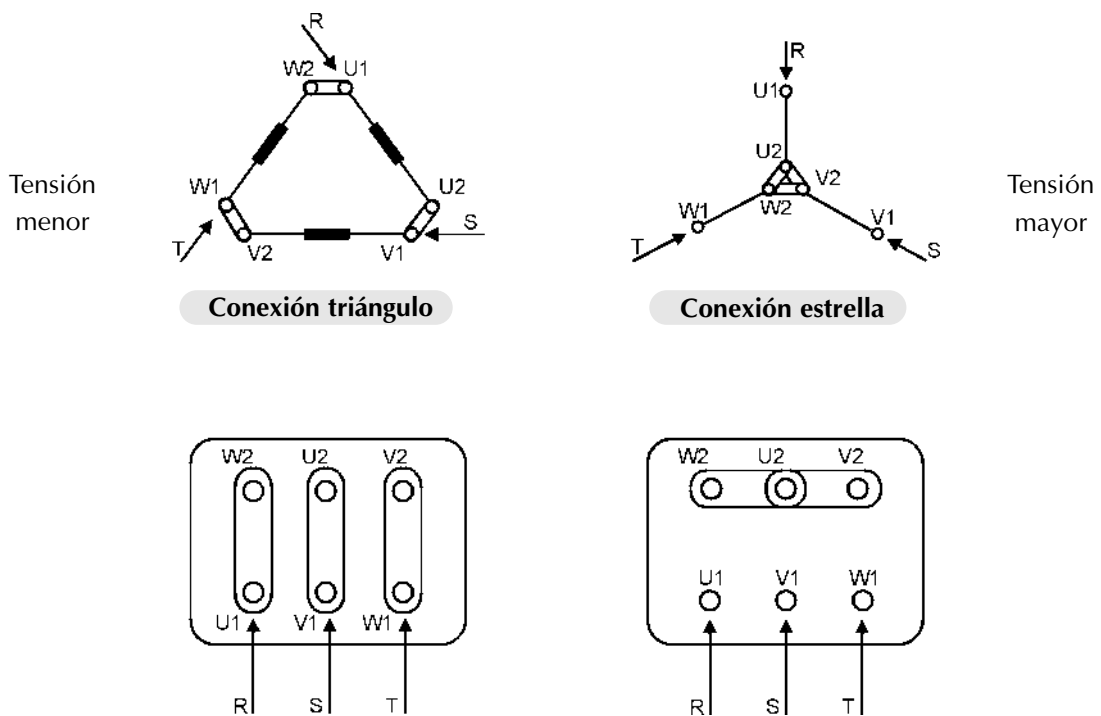

**MOD. FD-3.000 r.p.m.**

**PLANO DE DESPIECE - DETAIL DRAWING - VUE ECLATÉE - DISEGNO ESPLOSO**

**FD 14 - 15 - 16**

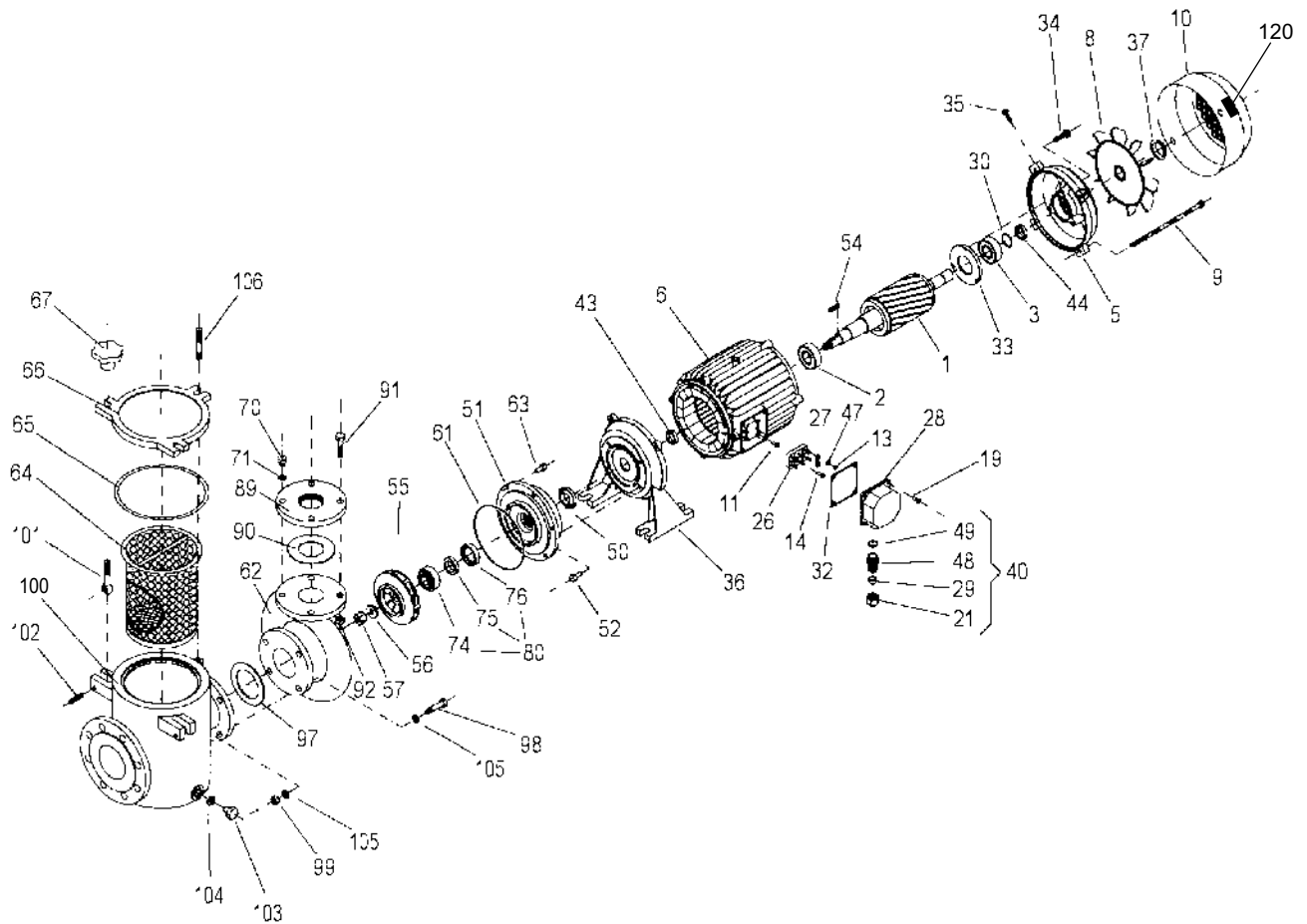

**Fig. 3**

POS.	DENOMINACIÓN	DENOMINATION
1	Eje rotor	Shaft with rotor
2	Cojinete motor lado bomba	Motor ball bearing pump side
3	Cojinete motor lado ventilador	Motor ball bearing fan side
5	Tapa motor lado ventilador	Back motor cover
6	Carcasa estator	Motor case and winding
8	Ventilador	Fan
9	Espárrago cierre motor	Motor screw
10	Coraza ventilador	Fan cover
11	Tornillo tierra	Ground screw
13	Tuerca placa conexiones	Terminal box nut
14	Tornillo placa conexiones	Terminal box screw
19	Tornillo caja conexiones	Terminal case screw
21	Presna pasa cables	Press cable bolt three-phase
26	Placa conexiones trifásica	Terminal box three-phase
27	Puente placa conexiones	Terminal box bridges
28	Caja conexiones trifásica	Terminal box cover three-phase
29	Pasa cables trifásico	Cable bolt three-phase
30	Anillo retención cojinete lado vent.	Ball bearing retention washer fan side
32	Junta caja conexiones	Terminal box gasket
33	Tapeta cojinete motor	Motor ball bearing cover
34	Tornillo tapeta cojinete	Ball bearing cover screw
35	Tornillo fijación coraza	Fan cover screw
36	Tapa motor lado bomba	Motor cover pump side
37	Brida fijación ventilador	Fixing fan ring
40	Presnaestopa completo	Complete press cable
43	Retén motor lado bomba	Motor seal pump side
44	Retén motor lado ventilador	Motor seal fan side
47	Arandela placa conexiones	Terminal box washer
48	Soporte presnaestopa	Press cable bracket
49	Junta presnaestopa	Press cable gasket
50	Paragoteo	Throw-off-washer
51	Tapa soporte	Bracket cover

POS.	DENOMINACIÓN	DENOMINATION
52	Tornillo tapa soporte a motor	Bracket screw
54	Chaveta	Key
55	Turbina	Impeller
56	Arandela turbina	Impeller washer
57	Tuerca turbina	Impeller nut
61	Junta cuerpo bomba	Pump housing gasket
62	Cuerpo bomba	Pump housing
63	Espárrago cuerpo bomba	Pump housing screw
64	Cesta filtro	Filter basket
65	Junta tapa filtro	Filter cover gasket
66	Tapa filtro	Filter cover
67	Palomilla filtro	Filter thumb nut
70	Tapón purga bomba	Drain plug pump
71	Junta tapón purga bomba	Drain plug pump gasket
74	Parte dinámica (sello mecánico)	Shaft seal (rotating)
75	Cara roce estática (sello mecánico)	Shaft seal (stationary)
76	Junta (sello necánico)	Shaft seal gasket
80	Sello completo	Complete shaft seal
89	Contra brida impulsión	Impulsion flange
90	Junta brida impulsión	Impulsion flange gasket
91	Tornillo brida impulsión	Impulsion flange screw
92	Tuerca tornillo brida impulsión	Impulsion flange nut
97	Junta filtro bomba	Filter housing gasket
98	Espárrago filtro bomba	Filter housing screw
99	Tuerca espárrago filtro bomba	Filter housing nut
100	Cuerpo filtro	Filter housing
101	Tornillo de ojo palomilla	Filter screw
102	Pasador tornillo de ojo	Filter screw bolt
103	Tapón desagüe filtro	Filter drain plug
104	Junta tapón desagüe filtro	Filter drain plug gasket
105	Arandela espárrago filtro bomba	Filter pump washer
106	Espárrago palomilla	Thumb screw
120	Placa características	Characteristics card (plate)

**MOD. FD-3.000 r.p.m.**

**PLANO DE DESPIECE - DETAIL DRAWING - VUE ECLATÉE - DISEGNO ESPLOSO**

**FD 17-18**

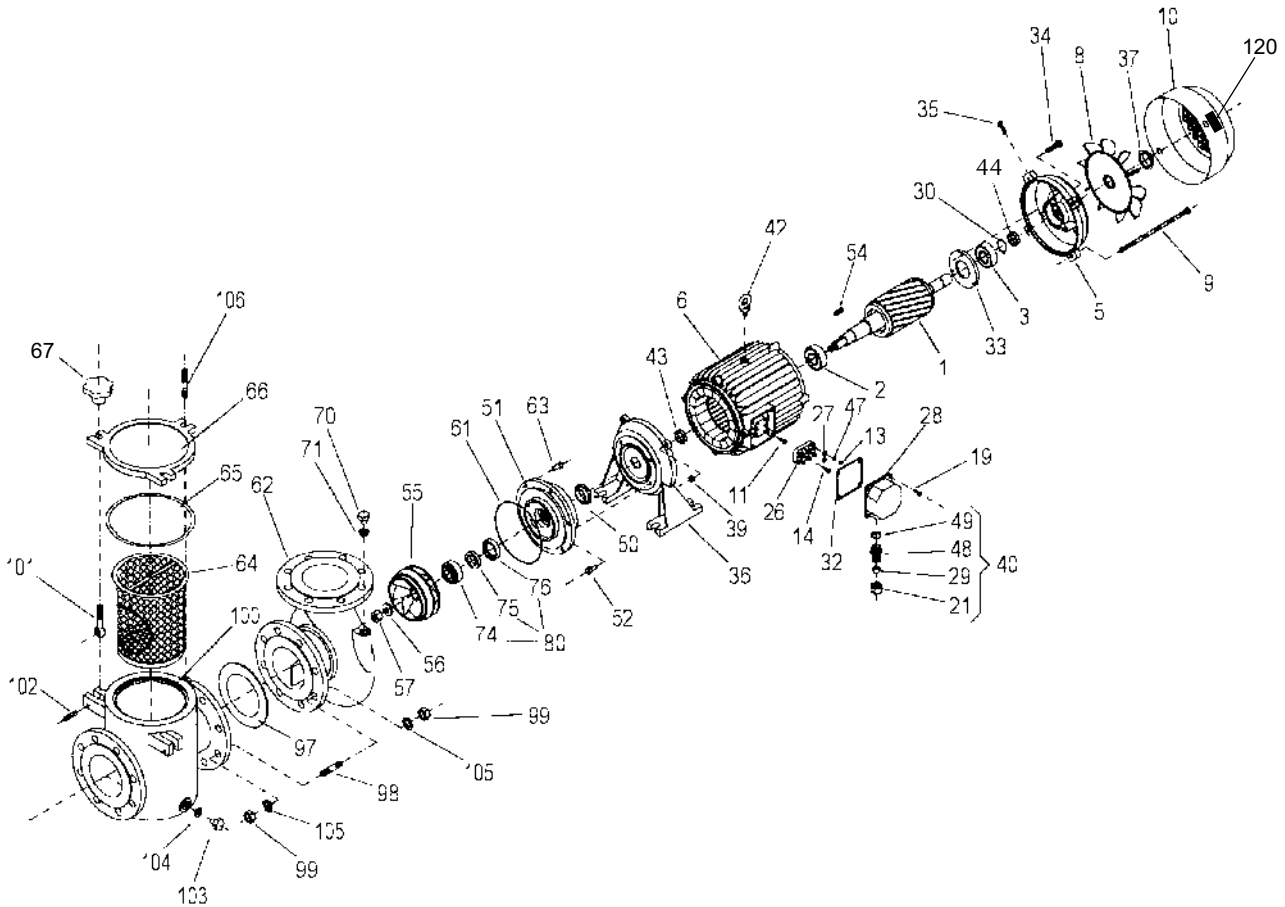

**Fig. 3**

POS.	DENOMINACIÓN	DENOMINATION
1	Eje rotor	Shaft with rotor
2	Cojinete motor lado bomba	Motor ball bearing pump side
3	Cojinete motor lado ventilador	Motor ball bearing fan side
5	Tapa motor lado ventilador	Back motor cover
6	Carcasa estator	Motor case and winding
8	Ventilador	Fan
9	Espárrago cierre motor	Motor screw
10	Coraza ventilador	Fan cover
11	Tornillo tierra	Ground screw
13	Tuerca placa conexiones	Terminal box nut
14	Tornillo placa conexiones	Terminal box screw
19	Tornillo caja conexiones	Terminal case screw
21	Prensa pasa cables	Press cable bolt three-phase
26	Placa conexiones trifásica	Terminal box three-phase
27	Puente placa conexiones	Terminal box bridge
28	Tapa caja conexiones trifásica	Terminal case cover three-phase
29	Pasa cables trifásico	Cable bolt three-phase
30	Anillo retención cojinete lado ventilador	Ball bearing retention washer fan side
32	Junta caja conexiones	Terminal box gasket
33	Tapeta cojinete motor	Motor ball bearing cover
34	Tornillo tapeta cojinete	Ball bearing cover screw
35	Tornillo coraza ventilador	Fan cover screw
36	Tapa motor lado bomba	Motor cover side pump
37	Brida fijación ventilador	Fixing fan ring
39	<b>FD-18</b> Tuerca espárrago cierre motor	Motor nut screw
40	Prensaestopa completo	Complete press cable
42	<b>FD-18</b> Tornillo de cáncamo	Eyebolt screw
43	Retén motor lado bomba	Motor seal pump side
44	Retén motor lado ventilador	Motor seal fan side
47	Arandela placa conexiones	Terminal box washer
50	Paragoteo	Throw-off-cover-washer

POS.	DENOMINACIÓN	DENOMINATION
51	Tapa soporte	Bracket cover
52	Tornillo tapa soporte a motor	Bracket screw
54	Chaveta	Key
55	Turbina	Impeller
56	Arandela turbina	Impeller washer
57	Tuerca turbina	Impeller nut
61	Junta cuerpo bomba	Pump housing gasket
62	Cuerpo bomba	Pump housing
63	Espárrago cuerpo bomba	Pump housing screw
64	Cesta filtro	Filter basket
65	Junta tapa filtro	Filter cover gasket
66	Tapa filtro	Filter cover
67	Palomilla filtro	Filter thumb nut
70	Tapón purga bomba	Drain plug pump
71	Junta tapón purga	Pump drain plug gasket
74	Parte dinámica (Sello mecánico)	Shaft seal (rotating)
75	Cara roce estática (Sello mecánico)	Shaft seal (stationary)
76	Junta (Sello mecánico)	Shaft seal gasket
80	Sello completo	Complete shaft seal
97	Junta filtro bomba	Filter housing gasket
98	Espárrago filtro bomba	Filter housing screw
99	Tuerca espárrago filtro bomba	Filter housing nut
100	Cuerpo filtro	Filter housing
101	Tornillo de ojo palomilla	Filter screw
102	Pasador tornillo de ojo	Filter screw bolt
103	Tapón desagüe filtro	Filter drain plug gasket
104	Junta tapón desagüe	Drain plug gasket
105	Arandela espárrago filtro bomba	Filter pump washer
106	Espárrago palomilla filtro	Thumb screw
120	Placa de características	Characteristics card

**MOD. FD-3.000 r.p.m.**

**PLANO DE DESPIECE - DETAIL DRAWING - VUE ECLATÉE - DISEGNO ESPLOSO**

**FD 19**

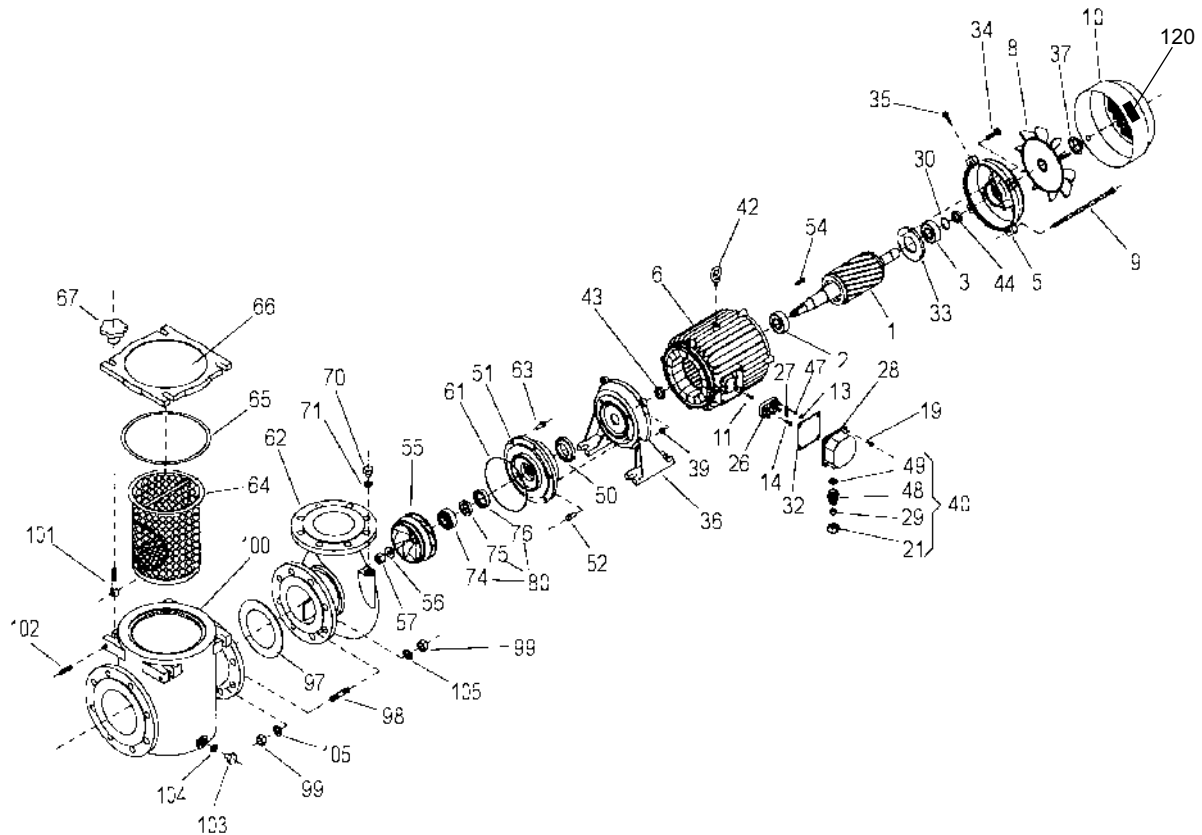

**Fig. 3**

POS.	DENOMINACIÓN	DENOMINATION	POS.	DENOMINACIÓN	DENOMINATION
1	Eje rotor	Shaft with rotor	48	Soporte prensaestopa	Press cable bracket
2	Cojinete motor lado bomba	Motor ball bearing pump side	49	Junta prensaestopa	Press cable gasket
3	Cojinete motor lado ventilador	Motor ball bearing fan side	50	Paragoteo	Throw-off-washer
5	Tapa motor lado ventilador	Back motor cover	51	Tapa soporte	Bracket cover
6	Carcasa estator	Motor case and winding	52	Tornillo tapa soporte a motor	Bracket screw
8	Ventilador	Fan	54	Chaveta	Key
9	Espárrago cierre motor	Motor screw	55	Turbina	Impeller
10	Coraza ventilador	Fan cover	56	Arandela turbina	Impeller washer
11	Tornillo tierra	Ground screw	57	Tuerca turbina	Impeller nut
13	Tuerca placa conexiones	Terminal box nut	61	Junta cuerpo bomba	Pump housing screw
14	Tornillo placa conexiones	Terminal box screw	62	Cuerpo bomba	Pump housing
19	Tornillo caja conexiones	Terminal case screw	63	Espárrago cuerpo bomba	Pump housing screw
21	Prensa pasa cables	Press cable bolt	64	Cesta filtro	Filter basket
26	Placa conexiones trifásica	Terminal box three-phase	65	Junta tapa filtro	Filter cover gasket
27	Puente placa conexiones	Terminal box bridge	66	Tapa filtro	Filter cover
28	Caja conexiones trifásica	Terminal case three-phase	67	Palomilla filtro	Filter thumb nut
29	Pasacables trifásico	Cable bolt three-phase	70	Tapón purga bomba	Drain plug pump
30	Anillo ret. cojinete lado ventilador	Ball bearing retention washer fan side	71	Junta tapón purga bomba	Drain plug pump gasket
32	Junta caja conexiones	Terminal box gasket	74	Parte dinámica (Sello mecánico)	Shaft seal (rotating)
33	Tapeta cojinete motor	Motor ball bearing cover	75	Cara roce estática (Sello mecánico)	Shaft seal (stationary)
34	Tornillo tapeta cojinete	Ball bearing cover screw	76	Junta (Sello mecánico)	Shaft seal gasket
35	Tornillo fijación coraza	Fan cover screw	80	Sello completo	Shaft seal complete
36	Tapa motor lado bomba	Motor cover pump side	97	Junta filtro bomba	Filter housing gasket
37	Brida fijación ventilador	Fixing fan ring	98	Espárrago filtro bomba	Filter housing screw
39	Tuerca espárrago cierre motor	Motor nut screw	99	Tuerca espárrago filtro bomba	Filter housing nut
40	Prensaestopa completo	Complete press cable	100	Cuerpo filtro	Filter housing
42	Tornillo de cáncamo	Eyebolt screw	101	Tornillo de ojo palomilla	Filter screw
43	Retén motor lado bomba	Motor seal pump side	102	Pasador tornillo de ojo	Filter screw bolt
44	Retén motor lado ventilador	Motor seal fan side	103	Tapón desagüe filtro	Filter drain plug
47	Arandela placa conexiones	Terminal box washer	104	Junta tapón desagüe	Drain plug gasket
			105	Arandela espárrago filtro bomba	Filter pump washer
			120	Placa de características	Characteristics card

**MOD. FD-3.000 r.p.m.**

**PLANO DE DESPIECE - DETAIL DRAWING - VUE ECLATÉE - DISEGNO ESPLOSO**

**FD 20 - 21 - 22**

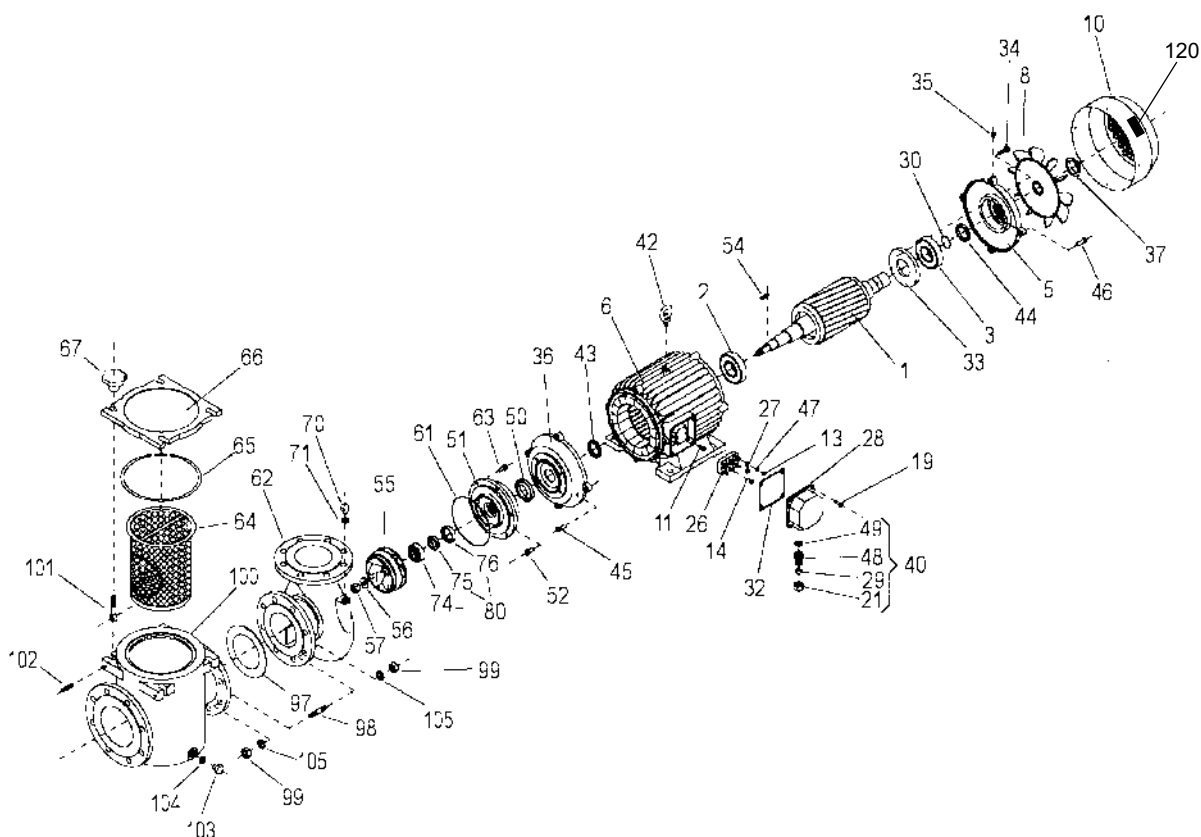

**Fig. 3**

POS.	DENOMINACIÓN	DENOMINATION
1	Eje rotor	Shaft with rotor
2	Cojinete motor lado bomba	Motor ball bearing pump side
3	Cojinete motor lado ventilador	Motor ball bearing fan side
5	Tapa motor lado ventilador	Back motor cover
6	Carcasa estator	Motor case and winding
8	Ventilador	Fan
10	Coraza ventilador	Fan cover
11	Tornillo tierra	Ground screw
13	Tuerca placa conexiones	Terminal box nut
14	Tornillo placa conexiones	Terminal box screw
19	Tornillo caja conexiones	Terminal case screw
21	Prensa pasa cables	Press cable bolt three-phase
26	Placa conexiones trifásica	Terminal box three-phase
27	Puente placa conexiones	Terminal box bridge
28	Caja conexiones trifásica	Terminal case three-phase
29	Pasacables trifásico	Cable bolt three-phase
30	Anillo ret. cojinete lado ventilador	Ball bearing retention washer fan side
32	Junta caja conexiones	Terminal box gasket
33	Tapeta cojinete motor	Motor ball bearing cover
34	Tornillo tapeta cojinete	Ball bearing cover screw
35	Tornillo fijación coraza	Fan cover screw
36	Tapa motor lado bomba	Motor cover pump side
37	Brida fijación ventilador	Fixing fan ring
40	Prensaestopa completo	Complete press cable
42	Tornillo de cáncamo	Eyebolt screw
43	Retén motor lado bomba	Motor seal pump side
44	Retén motor lado ventilador	Motor seal fan side
45	Tornillo tapa motor lado bomba	Screw motor cover pump side
46	Tornillo tapa motor lado ventilador	Screw motor cover fan side
47	Arandela placa conexiones	Terminal box washer
48	Soporte prensaestopa	Press cable bracket

POS.	DENOMINACIÓN	DENOMINATION
49	Junta prensaestopa	Press cable gasket
50	Paragoteo	Throw-off-washer
51	Tapa soporte	Bracket cover
52	Tornillo tapa soporte a motor	Bracket screw
54	Chaveta	Key
55	Turbina	Impeller
56	Arandela turbina	Impeller washer
57	Tuerca turbina	Impeller nut
61	Junta cuerpo bomba	Pump housing gasket
62	Cuerpo bomba	Pump housing
63	Espárrago cuerpo bomba	Pump housing screw
64	Cesta filtro	Filter basket
65	Junta tapa filtro	Filter cover gasket
66	Tapa filtro	Filter cover
67	Palomilla filtro	Filter thumb nut
70	Tapón purga bomba	Drain plug pump
71	Junta tapón purga bomba	Gasket drain plug pump
74	Parte dinámica (Sello mecánico)	Shaft seal (rotating)
75	Cara roce estática (Sello mecánico)	Shaft seal (stationary)
76	Junta (Sello mecánico)	Shaft seal gasket
80	Sello mecánico	Complete shaft seal
97	Junta filtro bomba	Filter housing gasket
98	Espárrago filtro bomba	Filter housing screw
99	Tuerca espárrago filtro bomba	Filter housing nut
100	Cuerpo filtro	Filter housing
101	Tornillo de ojo palomilla	Filter screw
102	Pasador tornillo de ojo	Filter screw bolt
103	Tapón desagüe filtro	Filter drain plug
104	Junta tapón desagüe	Drain plug gasket
105	Arandela espárrago filtro bomba	Filter pump washer
120	Placa de características	Characteristics card

**MOD. FD-3.000 r.p.m.**

**CARACTERÍSTICAS Y DIMENSIONES - CHARACTERISTICS AND DIMENSIONS  
CARACTERISTIQUES ET DIMENSIONS - CARATTERISTICHE E DIMENSIONI**

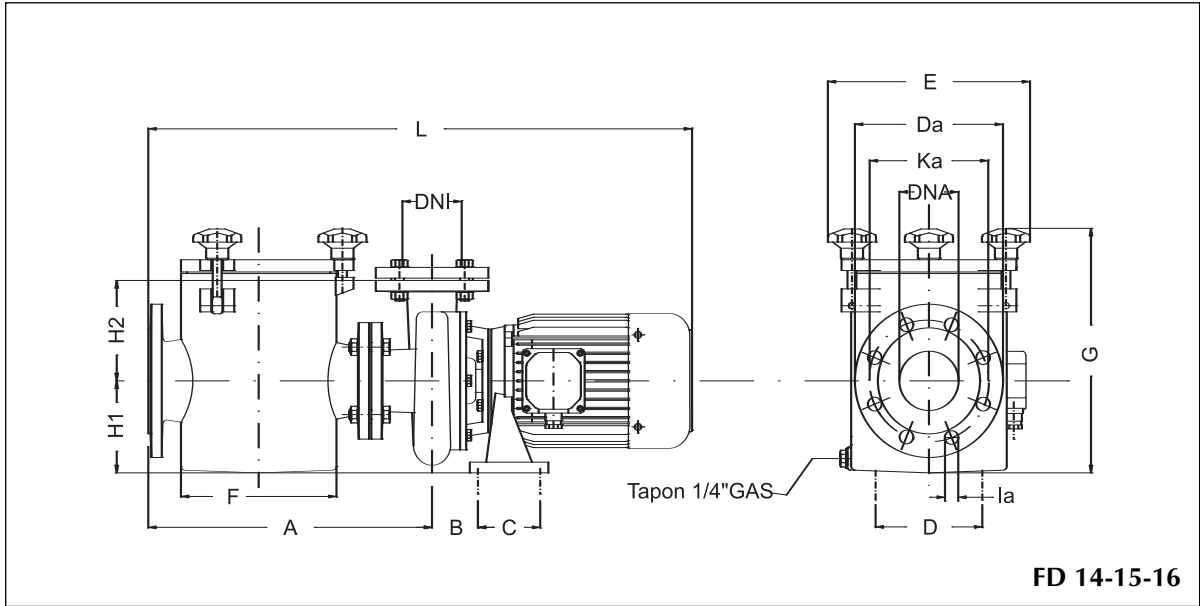

**FD 14-15-16**

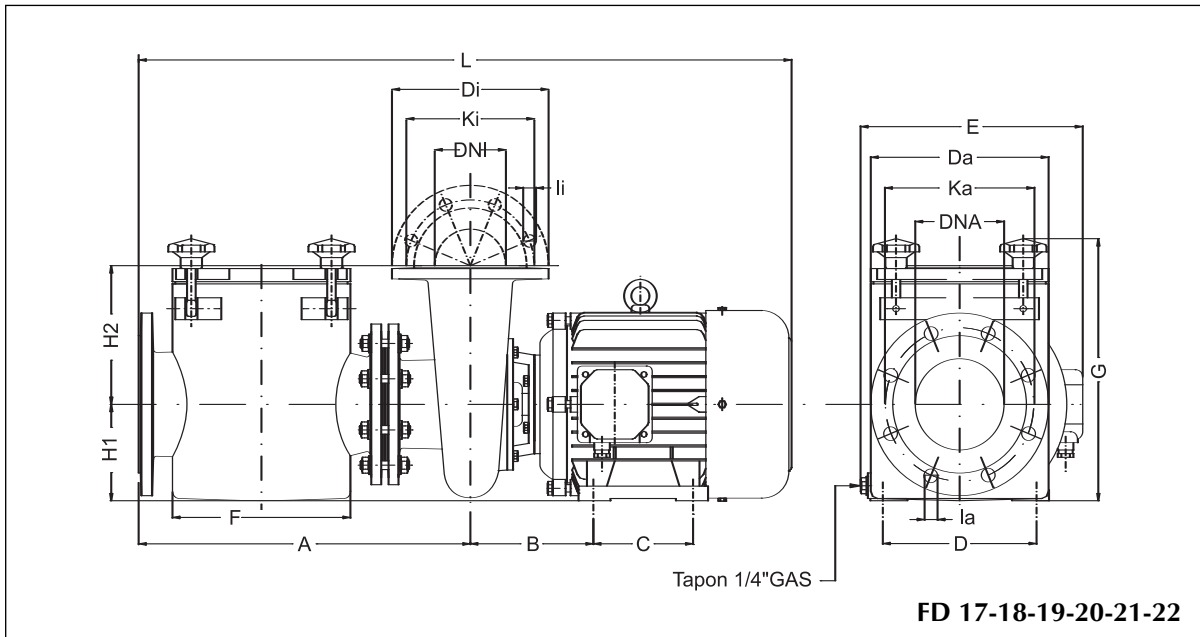

**FD 17-18-19-20-21-22**

Tipo Type	BRIDA DE ASPIRACIÓN				BRIDA DE IMPULSION				DIMENSIONES EN mm										
	DNA	Da	Ka	la	DNI	DI	Ki	li	A	B	C	D	E	F	G	H1	H2	L	KG.
FD-14	80	200	160	19	R2"GAS	-	-	-	383	62	84	144	273	210	319	120	130	735	50
FD-15	80	200	160	19	R2"GAS	-	-	-	383	62	84	144	273	210	319	120	130	735	51.5
FD-16	80	200	160	19	R2"GAS	-	-	-	383	62	84	144	273	210	327	128	130	762	55.5
FD-17	100	220	180	19	100	220	180	19	420	76	84	144	288	210	327	128	190	817	64
FD-18	100	220	180	19	100	220	180	19	420	72	112	176	288	210	331	132	190	831	72
FD-19	125	250	210	19	100	220	180	19	466	72	112	176	290	250	360	132	190	876	85
FD-20	125	250	210	19	100	220	180	19	466	173	140	216	312	250	360	132	190	918	95
FD-21	125	250	210	19	100	220	180	19	466	173	140	216	312	250	360	132	190	918	100
FD-22	125	250	210	19	100	220	180	19	466	173	178	216	312	250	360	132	190	956	110