

# INSTRUCTION MANUAL

BUILT-IN OVEN

EN

SAP3900X



Dear customer, we would like to thank you for your confidence in us.

By choosing a Smeg product, you have opted for solutions where research for beauty meets innovative technical design to provide unique pieces of furniture.

We hope you get the most out of your household appliance.

Kindest regards.

# Contents

<b>1</b>	<b>Instructions</b>	<b>4</b>
1.1	General safety instructions	4
1.2	Manufacturer liability	5
1.3	Appliance purpose	5
1.4	Disposal	5
1.5	Identification plate	6
1.6	This user manual	6
1.7	How to read the user manual	6
<b>2</b>	<b>Description</b>	<b>7</b>
2.1	General Description	7
2.2	Control panel	8
2.3	Other parts	8
2.4	Available accessories	9
<b>3</b>	<b>Use</b>	<b>10</b>
3.1	Instructions	10
3.2	First use	10
3.3	Using the accessories	11
3.4	Using the storage compartment	11
3.5	Using the oven	12
3.6	Cooking advice	15
3.7	Special functions	19
3.8	Preset recipes	21
3.9	Personal recipes	26
3.10	Settings	29
<b>4</b>	<b>Cleaning and maintenance</b>	<b>31</b>
4.1	Instructions	31
4.2	Cleaning the surfaces	31
4.3	Ordinary daily cleaning	31
4.4	Food stains or residues	31
4.5	Removing the door	31
4.6	Cleaning the door glazing	32
4.7	Cleaning the inside of the oven	32
4.8	Pyrolytic: automatic oven cleaning	33
4.9	Extraordinary maintenance	35
<b>5</b>	<b>Installation</b>	<b>37</b>
5.1	Electrical connection	37
5.2	Cable replacement	38
5.3	Positioning	38

We advise you to read this manual carefully, which contains all the instructions for maintaining the appliance's aesthetic and functional qualities.

For further information on the product: [www.smeg.com](http://www.smeg.com)



# Instructions

## 1 Instructions

### 1.1 General safety instructions

#### Risk of personal injury

- During use the appliance and its accessible parts become very hot.
- Never touch the heating elements during use.
- Keep children under eight years of age at a safe distance if they are not constantly supervised.
- Children must never play with the appliance.
- Never rest metallic objects such as knives, forks, spoons and lids on the appliance during use.
- Switch the appliance off immediately after use.
- Never try to put out a fire or flames with water: turn off the appliance and smother the flames with a fire blanket or other appropriate cover.
- The appliance must never be cleaned by unsupervised children.
- Have qualified personnel carry out installation and assistance interventions according to the standards in force.

- Do not modify this appliance.
- Do not insert pointed metal objects (cutlery or utensils) into the slots in the appliance.
- Do not try to repair the appliance yourself or without the intervention of a qualified technician.
- If the power supply cable is damaged, contact technical support immediately and they will replace it.

#### Risk of damaging the appliance

- Do not use abrasive or corrosive detergents on glass parts (e.g. powder products, stain removers and metallic sponges).
- Use wooden or plastic utensils.
- Do not seat on the appliance.
- Do not use steam jets for cleaning the appliance.
- Do not obstruct ventilation openings and heat dispersal slots.
- Never leave the appliance unattended during cooking operations where fats or oils could be released.
- Never leave objects on the cooking surface.
- Do not use the appliance to heat rooms for any reason.



## For this appliance

- Ensure that the appliance is switched off before replacing the bulb.
- Do not rest any weight or sit on the open door of the appliance.
- Take care that no objects are stuck in the doors.

## 1.2 Manufacturer liability

The manufacturer declines all liability for damage to persons or property caused by:

- use of the appliance other than the one envisaged;
- non-observance of the user manual provisions;
- tampering with any part of the appliance;
- use of non-original spare parts.

## 1.3 Appliance purpose

- This appliance is intended for cooking food in the home environment. Every other use is considered improper.
- This appliance may be used by children aged at least 8 and by people of reduced physical and mental capacity, or lacking in experience in the use of electrical appliances, as long they are supervised or instructed by adults who are responsible for their safety.
- The appliance is not designed to operate with external timers or with remote-control systems.

## 1.4 Disposal



This appliance must be disposed of separately from other waste (Directives 2002/95/EC, 2002/96/EC, 2003/108/EC). The appliance does not contain substances in quantities sufficient to be considered hazardous to health and the environment, in accordance with current European directives.

To dispose of the appliance:

- Cut the power supply cable and remove it along with the plug.



**Power voltage**

**Danger of electrocution**

- Disconnect the main power supply.
- Disconnect the power cable from the electrical system.
- Consign the appliance to the appropriate selective collection centres for electrical and electronic equipment waste, or deliver it back to the retailer when purchasing an equivalent product, on a one for one basis.



## Instructions

Our appliances are packed in non-polluting and recyclable materials.

- Consign the packing materials to the appropriate selective collection centres.



### Plastic packaging Danger of suffocation

- Do not leave the packaging or any part of it unattended.
- Do not let children play with the packaging plastic bags.

### 1.5 Identification plate

The identification plate bears the technical data, serial number and brand name of the appliance. Do not remove the identification plate for any reason.

### 1.6 This user manual

This user manual is an integral part of the appliance and must therefore be kept in its entirety and in an accessible place for the whole working life of the appliance.

Read this user manual carefully before using the appliance.

### 1.7 How to read the user manual

This user manual uses the following reading conventions:

#### Instructions



General information on this user manual, on safety and final disposal.

#### Description



Description of the appliance and its accessories.

#### Use



Information on the use of the appliance and its accessories, cooking advice.

#### Cleaning and maintenance



Information for proper cleaning and maintenance of the appliance.

#### Installation



Information for the qualified technician: installation, operation and inspection.



Safety instructions



Information



Advice

1. Use instruction sequence.

- Single use instruction.



## 2 Description

### 2.1 General Description

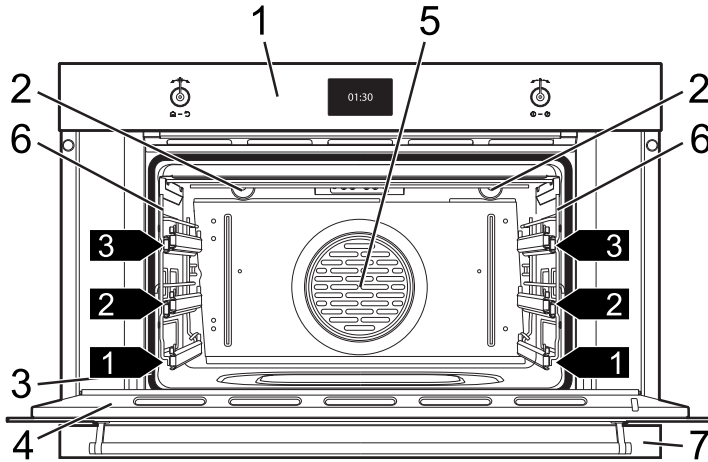

1 Control panel

2 Oven light

3 Seal

4 Door

5 Fan

6 Rack/tray support frames

7 Storage compartment

**1,2,3...** Frame shelf



# Description

## 2.2 Control panel

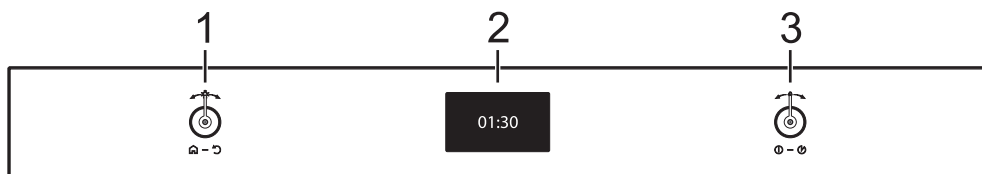

### Return knob (1)

Using this knob you can return to the appliance's previous menu item. It also lets you manually turn the oven light on and off.

### Display (2)

Displays the current time, the cooking parameters, and all the appliance's functions.

### Control knob (3)

This knob allows you to turn the appliance on and off and select the various available functions.

Turn the knob right or left to change/select the required item. Press to confirm.



Keep the knob pressed in for at least 5 seconds to immediately complete any cooking program.

## 2.3 Other parts

### Shelves

The appliance features shelves for positioning trays and racks at different heights. The insertion heights are indicated from the bottom upwards (see 2.1 General Description).

### Cooling fan

The fan cools the oven and comes into operation during cooking.

The fan causes a steady outflow of air from above the door which may continue for a brief period of time even after the appliance has been turned off.

### Interior lighting

The oven light comes on when the door is opened or any function is selected, except for **ECO P** and **P**.

Turn the return knob briefly to the right or left to activate or deactivate internal lighting.





## 2.4 Available accessories



Some models are not provided with all accessories.

### Rack

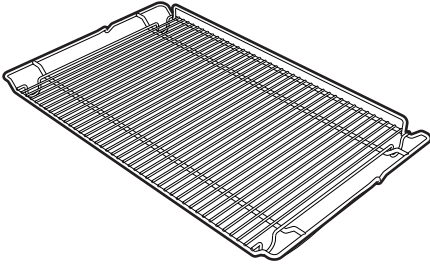

Useful for supporting containers with food during cooking.

### Tray rack

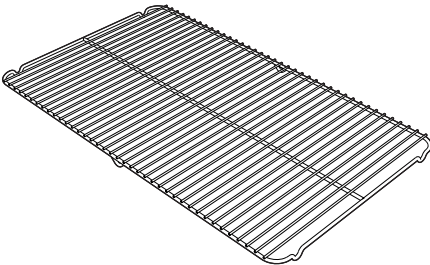

To be placed over the top of the oven tray; for cooking foods which may drip.

### Oven tray

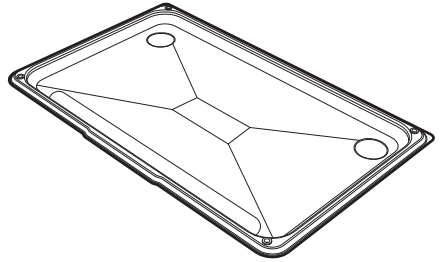

Useful for collecting fat from foods placed on the rack above.



The oven accessories intended to come into contact with food are made of materials that comply with the provisions of current legislation.



Original supplied and optional accessories can be requested to Authorised Assistance Centres. Use only original accessories supplied by the manufacturer.



## 3 Use

### 3.1 Instructions



**High temperature inside the oven during use**

**Danger of burns**

- Keep the oven door closed during cooking.
- Protect your hands wearing heat resistant gloves when moving food inside the oven.
- Do not touch the heating elements inside the oven.
- Do not pour water directly onto very hot trays.
- Do not allow children to get near the oven when it is in operation.



**High temperature inside the oven during use**

**Danger of fire or explosion**

- Do not spray any spray products near the oven.
- Do not use or leave flammable materials near the oven.
- Do not use plastic kitchenware or containers when cooking food.
- Do not put sealed tins or containers in the oven.
- Do not leave the oven unattended during cooking operations where fats or oils could be released.
- Remove all trays and racks which are not required during cooking.



**Improper use**

**Risk of damage to enamelled surfaces**

- Do not cover the bottom of the oven cavity with aluminium or tin foil sheets.
- If you wish to use greaseproof paper, place it so that it will not interfere with the hot air circulation inside the oven.
- Do not place pans or trays directly on the bottom of the oven cavity.
- Do not pour water directly onto very hot trays.



**High temperature inside the storage compartment**

**Danger of burns**

- Do not open the storage compartment when the oven is on and still hot.
- The items inside the storage compartment could be very hot after using the oven.

### 3.2 First use

1. Remove any protective film from the outside or inside of the appliance, including accessories.
2. Remove any labels (apart from the technical data plate) from the accessories and from the oven cavity.
3. Remove and wash all the appliance accessories (see 4 Cleaning and maintenance).
4. Heat the empty oven at the maximum temperature to burn off any residues left by the manufacturing process.



### 3.3 Using the accessories

#### Racks and trays

Racks and trays have to be inserted into the side guides until they come to a complete stop.

- The mechanical safety locks that prevent the rack from being taken out accidentally have to face downwards and towards the oven back.

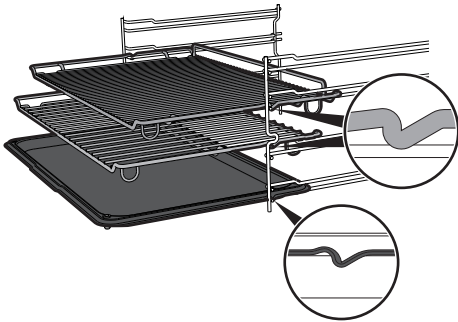

Gently insert racks and trays into the oven until they come to a stop.



Clean the trays before using them for the first time to remove any residues left by the manufacturing process.

#### Tray rack

The tray rack has to be inserted into the tray. In this way fat can be collected separately from the food which is being cooked.

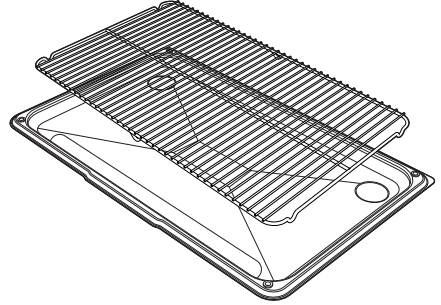

#### 3.4 Using the storage compartment

The storage compartment is at the bottom of the cooker. To open it, pull the handle towards you. It can be used to store cookware or metallic objects necessary when using the appliance.

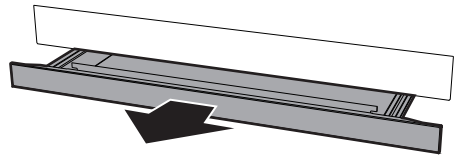



## 3.5 Using the oven

### First use

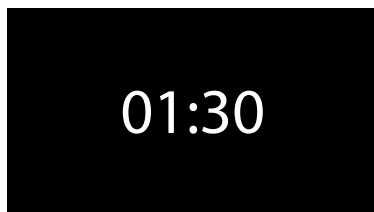

On the first use, or after a power failure, **00:00** will be flashing on the appliance's display. In order to be able to start any cooking program, the current time must be set (if the oven is being turned on for the first time, it is also recommended you set the required language).

Press the control knob to enter the settings menu, see "3.10 Settings".

### Cooking functions

1. Select "cooking functions" from the menu by pressing the control knob.

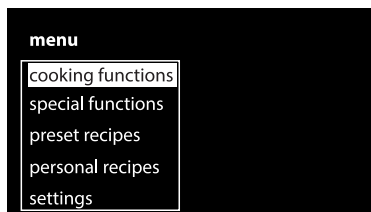

2. Turn the control knob to select the required function. Press the knob to confirm the selection.

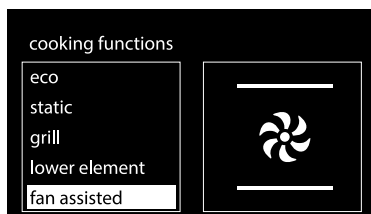

3. The appliance will begin the automatic pre-heat phase. The display will show the chosen function, the pre-set temperature, the current time and the progress bar of the temperature reached (preheating).

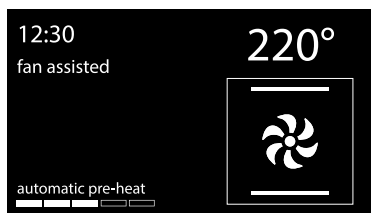

- Turn the control knob to change the preset temperature at any time. Press to confirm or wait 5 seconds.

**i** The appliance language is set to "English" by default.

When first connecting or after the power has been cut for a time it will be necessary to wait a few seconds before you can interact with the appliance.

### Favourites

Press the return knob from the clock screen to display the last programs or personal recipes used.





It is not recommended to place the dish in the oven during the automatic pre-heat stage.

4. When the preheating stage is over a buzzer will sound to indicate that the food can be placed inside the oven.



### Interrupting a function

Press the return knob to interrupt a cooking function. Select the required option and confirm it using the return knob.



Keep the control knob pressed in for at least 5 seconds to immediately interrupt cooking at any time and return to the main menu.

### Functions list



Certain functions are not available on all models.

#### ECO

##### Eco

The combination of the fan and the circulaire heating element, in ECO mode, is particularly indicated for cooking on a single shelf, with reduced power consumption.



##### Static

As the heat comes from above and below at the same time, this system is particularly suitable for certain types of food. Traditional cooking, also known as static cooking, is suitable for cooking just one dish at a time. Perfect for all types of roasts, bread and cakes and in any case particularly suitable for fatty meats such as goose and duck.



##### Grill

The heat coming from the grill element gives perfect grilling results above all for thin and medium thickness meat and in combination with the rotisserie (where fitted) gives the food an even browning at the end of cooking. Perfect for sausages, spare ribs and bacon. This function enables large quantities of food, particularly meat, to be grilled evenly.



## Lower element

The heat coming just from the bottom allows you to complete the cooking of foods that require a higher bottom temperature, without affecting their browning. Perfect for cakes, pies, tarts and pizzas.

## Fan assisted

The operation of the fan, combined with traditional cooking, ensures consistent cooking even with complex recipes. Perfect for biscuits and cakes, even when simultaneously cooked on several levels. (For multiple-level cooking, we recommend using the 1<sup>st</sup> and 4<sup>th</sup> shelves).

## Turbo

The combination of fan assisted cooking and traditional cooking allows different foods to be cooked on several levels extremely quickly and efficiently, without odours and flavours mingling. Perfect for large volumes that call for intense cooking. (For multiple-level cooking, we recommend using the 1<sup>st</sup> and 4<sup>th</sup> shelves).

## Fan with grill

The air produced by the fan softens the strong heatwave generated by the grill, grilling perfectly even very thick foods. Perfect for large cuts of meat (e.g. shin of pork).

## Fan + bottom

The combination of the fan with just the lower heating element allows cooking to be completed more rapidly. This system is recommended for sterilising or for finishing off the cooking of foods which are already well-cooked on the surface, but not inside, which therefore need a little more heat. Perfect for any type of food.

## Circulaire

The combination of the fan and the circulaire heating element (incorporated in the rear of the oven) allows you to cook different foods on several levels, as long as they need the same temperatures and type of cooking. Hot air circulation ensures instant and even distribution of heat. It will be possible, for instance, to cook fish, vegetables and biscuits simultaneously (on different levels) without mixing odours and flavours.

## Circulaire + fan with grill

The combination of fan assisted cooking and traditional cooking allows you to cook different foods on several levels extremely quickly and efficiently, without odours and flavours mingling. Perfect for large volumes that call for intense cooking.



## 3.6 Cooking advice

### General advice

- Use a fan assisted function to achieve consistent cooking at several levels.
- It is not possible to shorten cooking times by increasing the temperature (the food could be overcooked on the outside and undercooked on the inside).
- To prevent condensation from forming on the glass, hot food should not be left inside the oven for too long after cooking.

### Advice for cooking meat

- Cooking times vary according to the thickness and quality of the food and to consumer taste.
- Use a meat thermometer when roasting meat, or simply press on the roast with a spoon. If it is hard, it is ready; if not, it needs another few minutes cooking.

### Advice for cooking with the Grill and the Fan with grill

- Meat can be grilled even when it is put into the cold oven or into the preheated oven if you wish to change the effect of the cooking.
- With the Fan with grill function, we recommend that you preheat the oven before grilling.
- We recommend placing the food at the centre of the rack.

### Advice for cooking desserts/pastries and biscuits

- Use dark metal moulds: they help to absorb the heat better.
- The temperature and the cooking time depend on the quality and consistency of the dough.
- To check whether the dessert is cooked right through: at the end of the cooking time, put a toothpick into the highest point of the dessert. If the dough does not stick to the toothpick, the dessert is cooked.
- If the dessert collapses when it comes out of the oven, on the next occasion reduce the set temperature by about 10°C, selecting a longer cooking time if necessary.

### Advice for defrost and proving

- Place frozen foods without their packaging in a lidless container on the first shelf of the oven.
- Avoid overlapping the food.
- To defrost meat, use the rack placed on the second level and a tray on the first level. In this way, the liquid from the defrosting food drains away from the food.
- The most delicate parts can be covered with aluminium foil.
- For successful proving, a container of water should be placed in the bottom of the oven.



# Use

## To save energy



- Stop cooking a few minutes before the time normally used. Cooking will continue for the remaining minutes with the heat which has accumulated inside the oven.
- Reduce any opening of the door to a minimum to avoid heat dispersal.
- Keep the inside of the appliance clean at all times.
- (Where fitted) When it is not being used, remove the pizza plate and put the cover back in its slot.

## Minute minder during function

**i** This function only activates the buzzer, without stopping cooking.

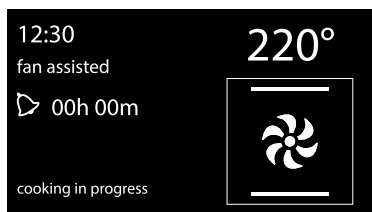
1. Press the control knob during a cooking function.



2. Turn the control knob right or left to set the duration (from 1 minute to 4 hours). After a few seconds, the  symbol stops flashing and the countdown starts.
3. Wait for the buzzer to indicate that the time has finished. The  symbol flashes.

 Turn the knob right or left to select another minute minder timer or press the control knob to deactivate the buzzer.

## Timed cooking

**i** Timed cooking is the function which allows a cooking operation to be started and then ended after a specific length of time set by the user.

**i** Activation of timed cooking cancels any minute minder timer which may previously have been set.

1. After selecting a cooking function and temperature, press the control knob twice.
2. Turn the knob right or left to set the minutes of cooking from 00:01 to 12:59. Keep the knob turned to produce a faster increase or decrease.
3. A few seconds after the required duration is set, the  symbol stops flashing and timed cooking starts.

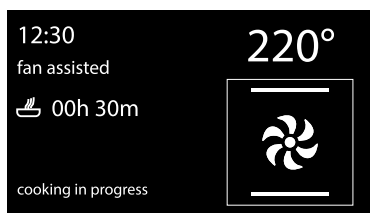





4. At the end of the cooking time “cooking completed” appears on the display and a buzzer will sound that can be deactivated by pressing the control knob.

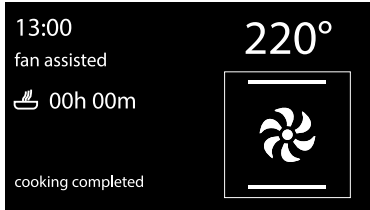

Turn the control knob to add some minutes of cooking time.





To extend the cooking time manually, press the control knob again. The appliance will resume its normal operation with the previously selected cooking settings.



To turn off the appliance see “Interrupting a function”.

### Modifying the data set during timed cooking

During operation, it is possible to modify timed cooking duration:

1. When the  symbol is lit steadily and the appliance is in the cooking stage, press the control knob.  will start flashing.
2. Turn the control knob right or left to alter the preset cooking time.



### Programmed cooking

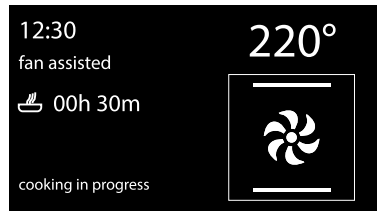

Programmed cooking is the function which allows a cooking operation to be stopped at an established time depending on the time set by the user, after which the oven will switch off automatically.

1. After selecting a function and a cooking temperature, press the control knob to set the cooking time.



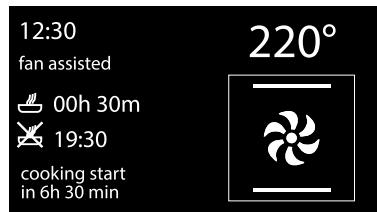

2. Press the control knob before the  symbol stops flashing to set the end of cooking time.
3. The  symbol flashes. Turn the knob right or left to set the end of cooking time.





## Use

4. After a few seconds the  and  symbols stop flashing. The appliance waits for the set start time.

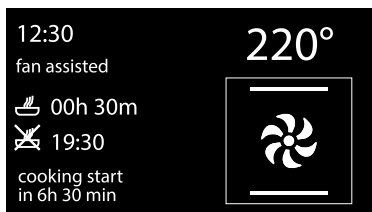

5. At the end of the cooking time "cooking completed" appears on the display and a buzzer will sound that can be deactivated by pressing the control knob.

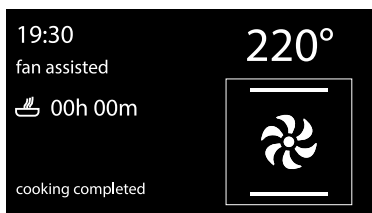







### Modifying the data set during programmed cooking



After modifying the cooking time, the end of cooking time must be re-set.

During operation, it is possible to modify programmed cooking duration:

1. When the  and  symbols are lit steadily and the appliance is waiting for cooking to start, press the temperature knob twice.  will start flashing.
2. Turn the control knob to alter the previously set cooking time.
3. Press the control knob again. The  symbol switches off and  starts flashing. The display shows the end of cooking time.
4. Turn the control knob to delay the end of cooking time.
5. After a few seconds the  and  symbols stop flashing and programmed cooking restarts its operation with the new settings.



To extend the cooking time manually, press the control knob again. The appliance will resume its normal operation with the previously selected cooking settings.



For safety reasons, it is not possible to set the end of cooking time by itself without setting the cooking duration.



### 3.7 Special functions

The special functions menu contains some functions like the minute minder with the oven off, cooking functions, keep warm or cleaning functions (certain models only).

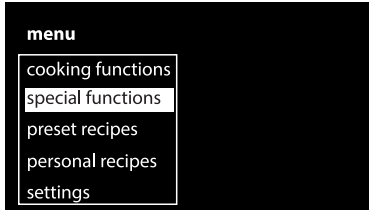

Certain functions are not available on all models.

#### List of special functions



##### Minute minder

This function sounds a buzzer when the time set has elapsed.



##### Proving

Leavening helped by heat from above allows any type of dough to prove, ensuring optimal results in a short time.



##### Defrost

Rapid defrost is assisted by switching on the fan and the upper heating element, ensuring even distribution of low-temperature air inside the oven.



##### Food warming

To heat food or keep it hot.



##### Keep warm

Useful to keep already cooked food warm without altering the taste and smell obtained during cooking.



##### Pyrolytic

Setting this function, the oven reaches temperatures up to 500°C, destroying all the grease which forms on the internal walls.



##### Eco pyrolytic

When this function is set, the oven executes a pyrolytic cycle at 500°C for a pre-set time. For use in the case of ovens which are not too dirty.



The more complex special functions are illustrated below. For functions such as Vapor Clean, Pyrolytic and Eco Pyrolytic, see "4 Cleaning and maintenance".



# Use

## Minute minder

1. Select minute minder from the special functions menu.

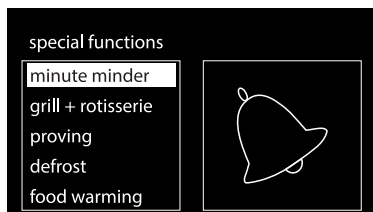

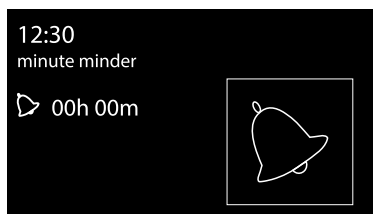

2. Turn the control knob right or left to set the duration (from 1 minute to 4 hours). After a few seconds, the  symbol stops flashing and the countdown starts.

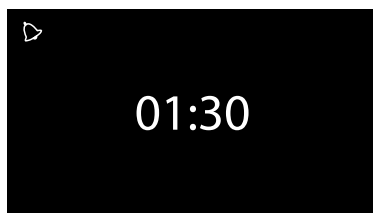

3. If you leave the minute minder setting screen, the  symbol will be displayed at the top left, indicating that a minute minder timer is active.



 You must return the counter to zero to remove the special minute minder.

 If a function is activated after setting a minute minder time, this time will be automatically used as a minute minder for the function.

 This function only activates the buzzer, without stopping cooking.

## Food warming

1. Position the tray on the first shelf and place the plates to be warmed in its centre.

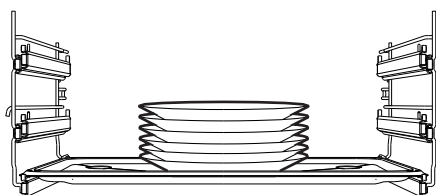

2. Select "food warming" from the special functions menu.

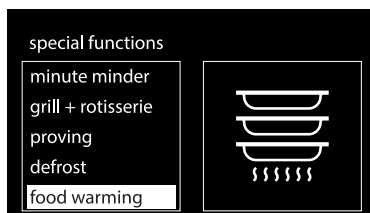

3. Press the control knob to activate the function, or turn it to adjust the preset temperature.

 Do not stack plates too high. Stack plates a maximum of 5/6 high.



### 3.8 Preset recipes

This mode allows you to select a pre-set food cooking program.

The appliance will automatically calculate the optimum cooking parameters based on the weight entered.

#### Starting a program

1. Select the required program with the control knob.



2. Select the sub-category of dish to cook.

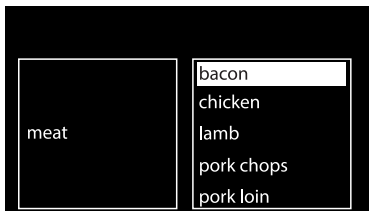

3. Select the type of cooking (where possible, based on the dish chosen)

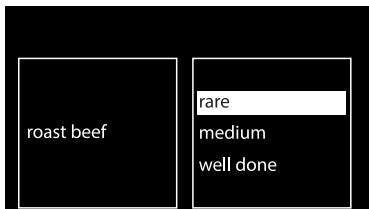

4. Select the weight of the food to cook by turning the control knob.



5. At this point it is possible to start the selected program, permanently modify the settings or delay the cooking.

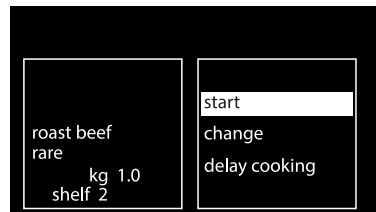

6. If you choose the "Start" option, cooking will start with the program's predefined settings and the display will show all the parameters set.

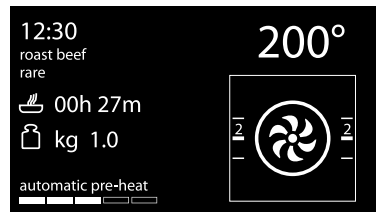

The time shown does not include the time to reach temperature. Once the set temperature has been reached, the cooking program will have the duration shown.



# Use



The predefined cooking parameters can be changed at any time, even after cooking has started.



It is not recommended to place the dish in the oven during the automatic pre-heat stage. Wait for the specific message.

7. A message will indicate when to place the food in the oven and enable the start of cooking.

3. Press the return knob to exit and finish the program.

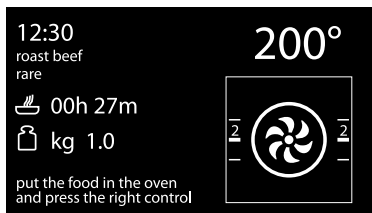

## Permanently changing a program

1. Select the program to change and the change option.

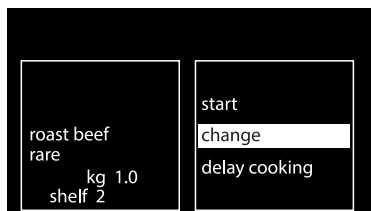

## Program end

1. When the program has finished, the appliance will warn the user with buzzers and the flashing symbol.

2. Select the function to associate with the program using the control knob.

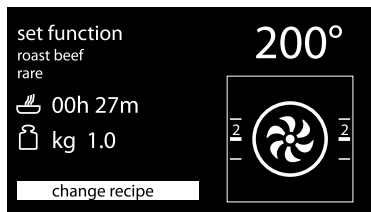
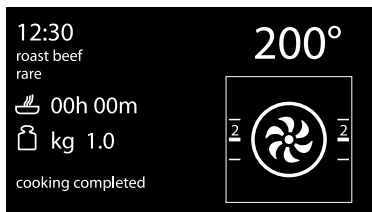

2. Press the control knob to perform cooking with the same parameters currently set (press the knob twice if the buzzer is active). The appliance will automatically restart cooking if it is at the correct temperature; otherwise it will also resume preheating.

3. Select the weight

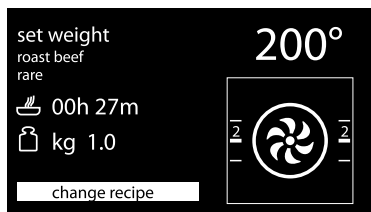

Cooking in sequence is useful to cook multiple dishes of the same type. For example, it can be used to cook several pizzas in a row.



4. Select the cooking time

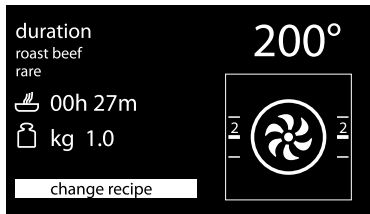

5. Select the temperature to be associated with the program.

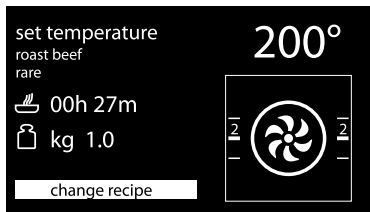

6. Select the shelf

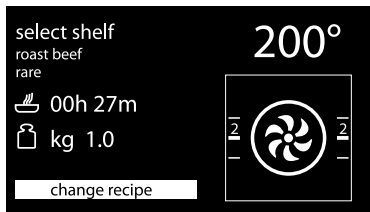

7. Pressing the control knob again will return to point 2 of the change sequence. You must press the return knob to save the program. The appliance will ask to confirm the changes which have just been made.

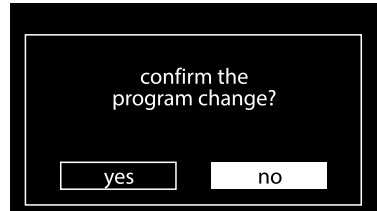

**i** If the changes are not confirmed, the program will remain unchanged.

8. If the changes are confirmed the display will show confirmation of this.





# Use

## Predefined program table

### BREAD

Subcategory	Cooking	Weight (Kg)	Function	Level	Temp. (°C)	Time (minutes)
Focaccia	-	1	Turbo	2	180	30
Leavened bread	-	1	Circulaire	2	200	45

### PASTA/RICE

Subcategory	Cooking	Weight (Kg)	Function	Level	Temp. (°C)	Time (minutes)
Lasagne	-	4	Static	1	230	40
Paella	-	0.5	Fan assisted	2	190	28
Pasta bake	-	2	Static	1	220	45
Quiche	-	0.5	Static	1	200	40

### PIZZA

Subcategory	Cooking	Weight (Kg)	Function	Level	Temp. (°C)	Time (minutes)
Pan baked pizza	-	1.5	Fan assisted	1	280	8

### PIES/FLANS

Subcategory	Cooking	Weight (Kg)	Function	Level	Temp. (°C)	Time (minutes)
Soufflé	-	0.5	Circulaire	2	180	40

### DESSERTS/PASTRIES

Subcategory	Cooking	Weight (Kg)	Function	Level	Temp. (°C)	Time (minutes)
Biscuits	-	0.6	Turbo	2	160	23
Brioche bread	-	1	Fan assisted	2	180	45
Bundt cake	-	1	Fan assisted	2	160	73
Croissants	-	0.6	Circulaire	2	160	40
Meringues	-	0.3	Turbo	2	120	113
Muffins	-	0.5	Circulaire	2	160	22
Profiteroles	-	0.5	Turbo	2	180	90
Sponge cake	-	1	Circulaire	2	160	65
Strudel	-	1	Static	2	170	50
Tart	-	1	Static	2	170	40

### FISH



# Use



Subcategory	Cooking	Weight (Kg)	Function	Level	Temp. (°C)	Time (minutes)
Fresh fish	-	0.5	Fan assisted	2	160	55
Frozen fish	-	0.5	Circulaire	2	160	65
Monkfish	-	0.8	Circulaire	2	160	65
Sea bass	-	1	Circulaire	2	160	60
Snapper	-	1	Circulaire	2	180	75
Turbot	-	1	Circulaire	2	160	95

## MEATS

Subcategory	Cooking	Weight (Kg)	Function	Level	Temp. (°C)	Time (minutes)
Bacon	-	0.8	Fan with grill	3	250	6
Chicken	roasted	0.5	Turbo	2	180	56
	medium	1.5	Turbo	2	180	71
Lamb	well done	1.5	Turbo	2	180	81
	-	1.5	Fan with grill	3	280	14
Pork chops	-	1.5	Fan with grill	3	280	11
Pork loin	-	1	Turbo	2	180	59
Pork sausages	-	1.5	Fan with grill	3	280	11
Pork spare ribs	-	1.5	Fan with grill	3	250	16
Rabbit	roasted	1.5	Circulaire	2	180	73
	rare	1	Circulaire	2	200	27
Roast beef	medium	1	Circulaire	2	200	29
	well done	1	Circulaire	2	200	32
Turkey	roasted	3	Fan assisted	1	180	100
Veal	-	1.2	Fan assisted	2	180	108

## SLOW COOKING

Subcategory	Cooking	Weight (Kg)	Function	Level	Temp. (°C)	Time (minutes)
Beef	rare	1	Static	2	90	210
	medium	1	Static	2	90	300
	well done	1	Static	2	90	507
Lamb	-	1	Turbo	2	90	600
Pork	-	1	Turbo	2	90	435
Veal	-	1	Turbo	2	90	600



# Use

## VEGETABLES

Subcategory	Cooking	Weight (Kg)	Function	Level	Temp. (°C)	Time (minutes)
Mixed vegetables	grilled	0.5	Grill	3	250	40
	roasted	1	Circulaire	2	170	50
Potatoes	frozen	0.5	Fan assisted	2	220	15
	roasted	1.5	Static	2	240	40



The cooking times in the table refer to the food indicated in the recipe and are a guide only; they may vary depending on personal taste.



The tables give the factory-set data. To reset a predefined program with the original settings after it has been modified, just enter the data given in the table above.



If ECO logic mode (see 3.9 Personal recipes) has been activated, cooking times or preheating times may vary.

### 3.9 Personal recipes

This menu allows you to enter a personal recipe with the parameters you wish to use. On first use, the appliance will only offer to let you add a new recipe. After storing your recipes, these will then be available in the relative menu.



Up to 10 personal recipes can be stored.

#### Adding a recipe

1. Select "add" from the personal recipes menu.





- Select the function the recipe is to use by turning the control knob.
- Select the shelf

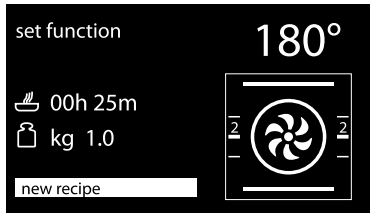

- Select the weight

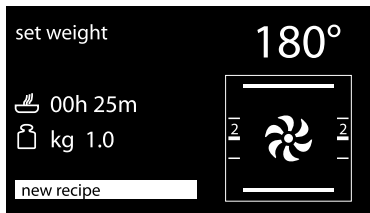

- Select the cooking time

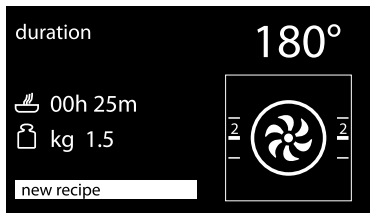

- Select the temperature

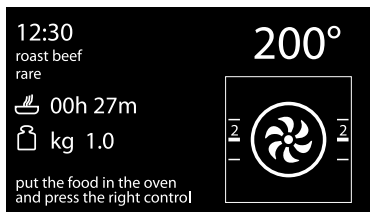

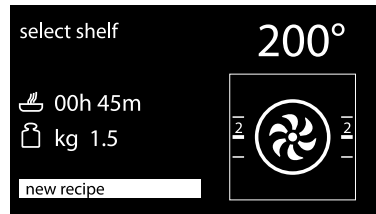

- Select the shelf

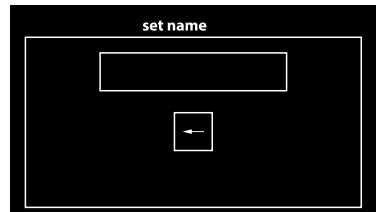

- You must press the return knob to save the recipe. Pressing the control knob will return to point 2 of the change sequence.
- Set the name of the recipe: you can choose characters by pressing the control knob. The  character deletes the previous letter. Press to confirm the displayed character.



 The recipe name can contain maximum 10 characters, including spaces.

 In order to be able to save the recipe, the name must contain at least one character.



# Use

- After entering the name of your recipe, press the return knob to confirm or cancel the information you have entered. Select "YES" if you wish to store the recipe.

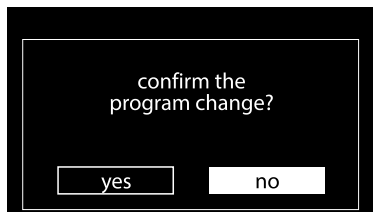

- Select the "start" option from the submenu.

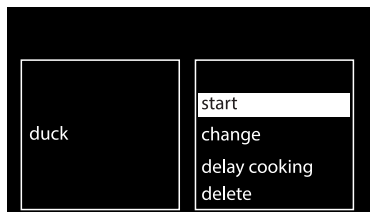

- Cooking will start with the parameters previously set for the recipe.

**i** If you select "NO", you will lose all changes made.

**i** During cooking it is always possible to modify the temperature and cooking time, but this will not be saved to the recipe for future use.

- If the changes are confirmed the display will show confirmation of this.

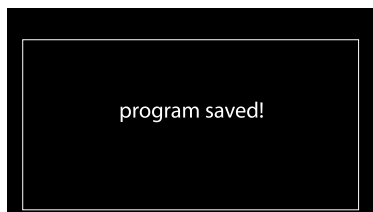

## Changing a personal recipe

- Select a previously saved personal recipe with the control knob (in the example, a recipe for "duck" has been saved).

## Starting a personal recipe

- Select a previously saved personal recipe with the control knob (in the example, a recipe for "duck" has been saved).



- Select the change option from the submenu.

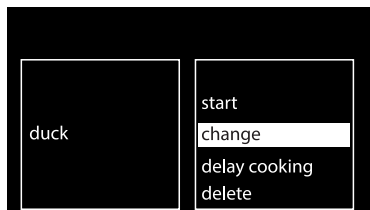



- Repeat the steps given in the “Adding a recipe” chapter, starting from point 2.

### Delay cooking

- Select a personal recipe.
- Select the “Delay cooking” option from the submenu.
- Select the end of cooking time with the control knob. The  symbol flashes.

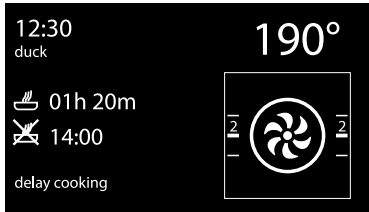

### Deleting a personal recipe

- Select a personal recipe.
- Select the “Delete” option from the submenu.
- Confirm the deletion. Select YES to permanently delete the recipe.

## 3.10 Settings

The product is set using this menu.

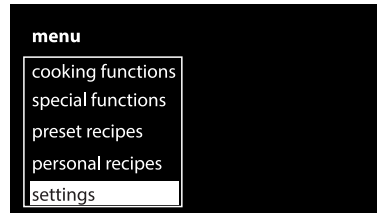

### Language

Sets the interface language from those available.



### Clock

Sets the time displayed.

- Turn the control knob right or left to set the hour.
- Press the control knob to move to setting the minute.
- Turn the control knob right or left to set the minute.
- Press the return knob to confirm.

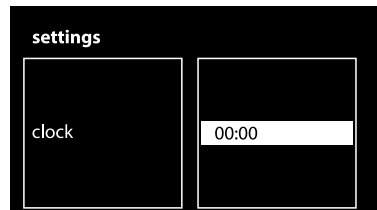



## Use

### Control lock

Allows the appliance to automatically lock the controls after one minute of normal operation without any intervention from the user.

To temporarily release the lock during cooking, hold the return knob down for 3 seconds. One minute after the last setting the lock will become active again.

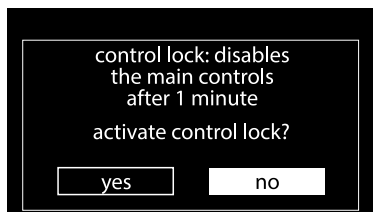

### Eco-Logic

This mode allows the appliance to limit the power used. The  symbol will appear on the display if this option is enabled.

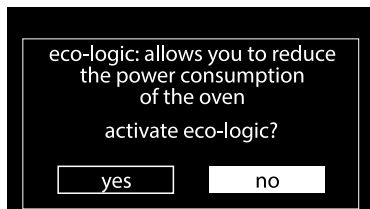

 Activating eco-logic mode means that preheating and cooking times may be extended.

### Sound

Whenever one of the knobs is pressed, the appliance beeps. This setting disables these sounds.

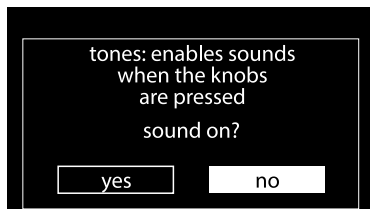

### Demo mode

This mode allows the appliance to deactivate all heating elements, while keeping the control panel active.

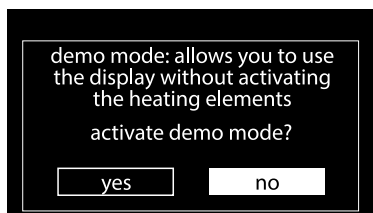

 If the mode is active, "demo mode" will be shown on the display.

 To use the appliance normally, set this mode to **OFF**.



## 4 Cleaning and maintenance

### 4.1 Instructions



**Improper use  
Risk of damage to surfaces**

- Do not use steam jets for cleaning the appliance.
- Do not use cleaning products containing chlorine, ammonia or bleach on steel parts or parts with metallic finishes on the surface (e.g. anodizing, nickel- or chromium-plating).
- Do not use abrasive or corrosive detergents on glass parts (e.g. powder products, stain removers and metallic sponges).
- Do not use rough or abrasive materials or sharp metal scrapers.

### 4.2 Cleaning the surfaces

To keep the surfaces in good condition, they should be cleaned regularly after use. Let them cool first.

### 4.3 Ordinary daily cleaning

Always use only specific products that do not contain abrasives or chlorine-based acids.

Pour the product onto a damp cloth and wipe the surface, rinse thoroughly and dry with a soft cloth or a microfibre cloth.

### 4.4 Food stains or residues

Do not use metallic sponges or sharp scrapers as they will damage the surfaces. Use ordinary non-abrasive products with the aid of wooden or plastic utensils if necessary. Rinse thoroughly and dry with a soft cloth or a microfibre cloth.

Do not allow residues of sugary foods (such as jam) to set inside the oven. If left to set for too long, they might damage the enamel lining of the oven.

### 4.5 Removing the door

For easier cleaning, the door can be removed and placed on a canvas.

To remove the door proceed as follows:

1. Open the door completely and insert two pins into the holes on the hinges indicated in the figure.

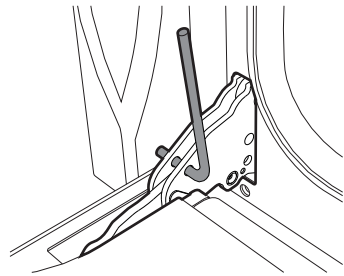

2. Grasp the door on both sides with both hands, lift it forming an angle of around 30° and remove it.

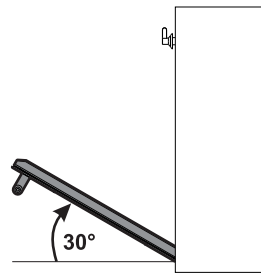

3. To reassemble the door, put the hinges in the relevant slots in the oven, making sure that grooved sections **A** are resting completely in the slots. Lower the door



# Cleaning and maintenance

and once it is in place remove the pins from the holes in the hinges.

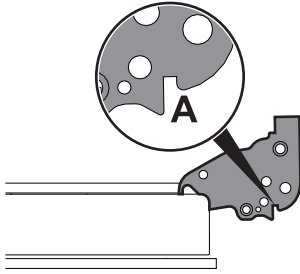

The oven should be operated at the maximum temperature for about 15-20 minutes after the use of specific products, to burn off the residues left inside the oven.



For easier cleaning, remove the door.

## 4.6 Cleaning the door glazing

The glass in the door should always be kept thoroughly clean. Use absorbent kitchen roll. In case of stubborn dirt, wash with a damp sponge and an ordinary detergent.



We recommend the use of cleaning products distributed by the manufacturer.

## 4.7 Cleaning the inside of the oven

For the best oven upkeep, clean it regularly after having allowed it to cool.

Take out all removable parts.

Clean the oven racks with warm water and non-abrasive detergent. Carefully rinse and dry the damp parts.

## Removing racks/trays support frames

Removing the rack/tray support frames enables the sides to be cleaned more easily.

Removing the rack/tray support frames:

- Pull the frame towards the inside of the oven to unhook it from its groove **A**, then slide it out of the seats **B** at the back.

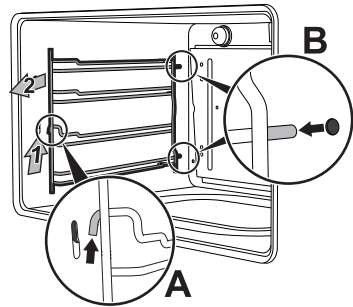

- When cleaning is complete, repeat the above procedures to put the guide frames back in.

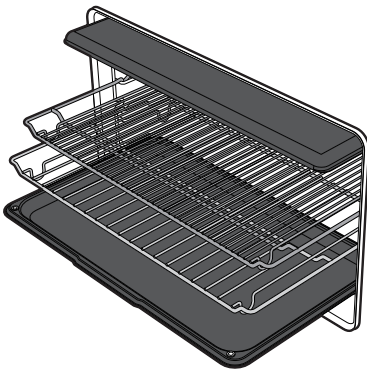





## 4.8 Pyrolytic: automatic oven cleaning



Pyrolytic is an automatic high-temperature cleaning procedure which causes dirt to dissolve. Thanks to this process, it is possible to clean the inside of the oven very easily.



### Improper use Risk of damage to surfaces

- Remove any food residues or large spills from previous cooking operations from the inside of the oven.
- Switch off the burners or electric hot plates of the hob installed above the oven.
- Remove the frames with telescopic guides before starting any pyrolytic cleaning cycle.



### Improper use Risk of damages to the appliance

- Remove the frames with telescopic guides before starting any pyrolytic cleaning cycle.

### Preliminary operations

Before starting the pyrolytic cycle:

- Clean the internal glass panel following the usual cleaning instructions.
- For very stubborn encrustations spray an oven cleaning product onto the glass (read the warnings on the product); leave for 60 minutes, then rinse and dry the glass using kitchen roll or a microfibre cloth.

- Completely remove all accessories from inside the oven (do not remove the upper guard)
- Remove the racks/trays support frames.
- Close the door.

### Pyrolytic function setting

1. Select the pyrolytic or eco pyrolytic option from the special functions menu.

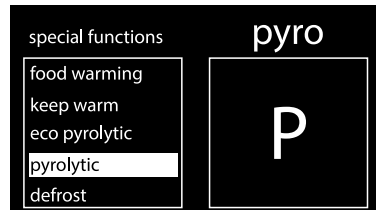
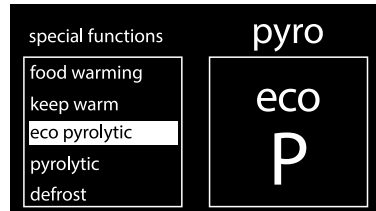

2. Turn the control knob to set the cleaning cycle duration from a minimum of 2 hours to a maximum of 3 hours (except for the

**eco P** function whose duration is 120 minutes).





## Cleaning and maintenance

- Press the control knob to start the pyrolytic cycle. The  symbol will now be lit solidly.



Recommended pyrolytic cycle duration:

- Light dirt: 2 ½ hours.
- Medium dirt: 3 hours.
- Heavy dirt: 3 ½ hours.

### Pyrolytic

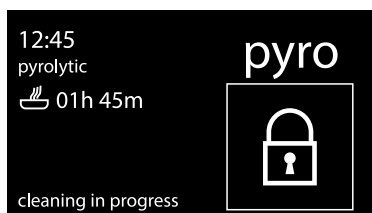

- The display shows “cleaning in progress” and the remaining time to indicate that the appliance is carrying out the automatic cleaning cycle. Two minutes after the pyrolytic cycle has started the door is locked (the door lock indicator light  comes on) by a device that prevents the door from being opened.



- At the end of the pyrolytic cycle, the door remains locked as long as the temperature inside the oven returns to safety levels. Wait for the oven to cool down and collect the residues deposited inside with a damp microfibre cloth.

**i**

During the first pyrolytic cycle, unpleasant odours may occur due to the normal evaporation of oily manufacturing substances. This is an absolutely normal phenomenon which disappears after the first pyrolytic cycle.

**i**

During the pyrolytic cycle the fans produce a more intense level of noise due to a greater rotation speed. This is an absolutely normal operation, intended to provide more effective heat dispersal. At the end of the pyrolytic cycle, the fans will continue to operate for long enough to avoid overheating the walls of adjacent units and the front of the oven.



If the pyrolytic cycle gives unsatisfactory results at minimum duration, it is recommended to set a longer time for successive cleaning cycles.



**i**

It is not possible to select any function once the door lock device has been activated.



## Setting of programmed pyrolytic cycle

It is possible to program the pyrolytic cycle start time like all other cooking functions.

6. After selecting the pyrolytic cycle duration, press the control knob. The display shows the current time and the  symbol comes on.
7. Turn the control knob to set the time you wish the pyrolytic cycle to finish.
8. After a few seconds, the  and  indicator lights remain lit steadily and the appliance waits for the set start time to start the cleaning cycle.



It is not possible to select any function once the door lock device has been activated. It remains possible, however, to switch off the appliance using the specific controls.

## 4.9 Extraordinary maintenance



Live parts

**Danger of electrocution**

- Disconnect the oven power supply.

### Replacing the internal light bulb

1. Unscrew bulb protector **1**, anticlockwise.
2. Replace the bulb **2** with one of the same type (25W). Use only oven bulbs (T 300°C).

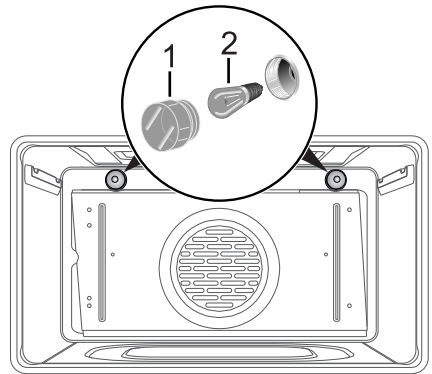

3. Re-fit bulb protector **1**.



## Cleaning and maintenance

### What to do if...

The display is completely off:

- Check the mains power supply.
- Check whether an omnipolar switch upstream of the appliance supply line is in the "ON" position.

The appliance does not heat up:

- Check whether it has been set in "showroom" mode (for further details see "Settings").

The controls do not respond:

- Check whether it has been set to "control lock" mode (for further details see "Settings").

The cooking times are longer than those indicated in the table:

- Check whether it has been set to "ecologic" mode (for further details see "Settings").

After the automatic cleaning cycle (pyrolytic) it is not possible to select a function:

- Verify whether the door lock has deactivated. If it has not, the oven has a safety device that does not allow functions to be selected while the door lock is active. This is because the temperature inside the oven is still too high to permit any type of cooking.

The display shows "Error 4":

- The door lock has not properly attached to the door. This might be because the door was accidentally opened during the door lock activation. Switch the oven off and on again, waiting a few minutes before selecting a new cleaning cycle.

If the door is opened during a fan assisted function, the fan stops:

- This is not a fault. It is a normal operation of the appliance, useful when cooking foods in order to avoid excessive heat escaping. When the door is closed, the oven will return to normal operation.



If the problem has not been resolved or in the case of other types of fault, contact your local technical support centre.



If other Error XX error messages are indicated:  
note down the error message, function and set temperature and contact your local technical support centre.



## 5 Installation

### 5.1 Electrical connection



**Power voltage  
Danger of electrocution**

- Have the electrical connection performed by authorised technical personnel.
- The appliance must be connected to earth in compliance with electrical system safety standards.
- Disconnect the main power supply.

#### General information

Check the grid characteristics against the data indicated on the plate.

The identification plate bearing the technical data, serial number and brand name is visibly positioned on the appliance.

Do not remove this plate for any reason.

The appliance works at 220-240 V~.

Use a three-core cable (3 x 1.5 mm<sup>2</sup> cable, referring to the cross section of the internal conductor).

Perform the ground connection using a wire that is 20 mm longer than the other wires.

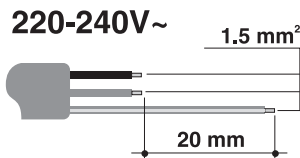

#### Fixed connection

Fit the power line with an omnipolar circuit breaker in compliance with installation regulations.

The circuit breaker should be located near the appliance and in an easily reachable position.

#### Connection with plug and socket

Make sure that the plug and socket are of the same type.

Avoid using adapters and shunts as these could cause overheating and a risk of burns.



# Installation

## 5.2 Cable replacement



**Power voltage**  
**Danger of electrocution**

- Disconnect the main power supply.

1. Unscrew the rear casing screws and remove the casing to access the terminal board.

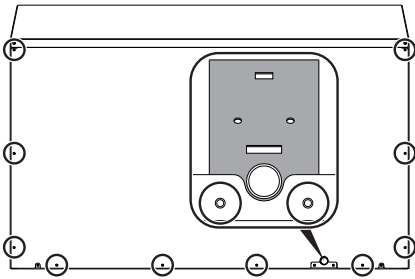

2. Replace the cable.
3. Make sure that the cables (for the oven or hob) follow the best route in order to avoid any contact with the appliance.

## 5.3 Positioning



**Heavy appliance**  
**Danger of crush injuries**

- Place the appliance into the piece of furniture with the aid of a second person.



**Pressure on the open door**  
**Risk of damages to the appliance**

- Never use the oven door to lever the appliance into place when fitting.
- Avoid exerting too much pressure on the oven door when open.



**Heat production during appliance operation**  
**Risk of fire**

- Check that the piece of furniture material is heat resistant.
- Check that the piece of furniture has the required slots.



## Fastening bushings

Remove the bushing covers inserted on the oven front.

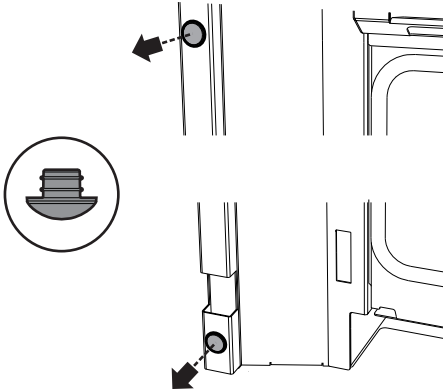

Cover the bushings with the covers removed previously.

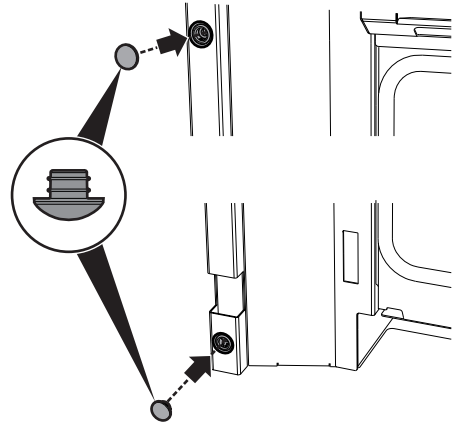

Mount the appliance into the recess.  
Secure the appliance to the piece of furniture using screws.

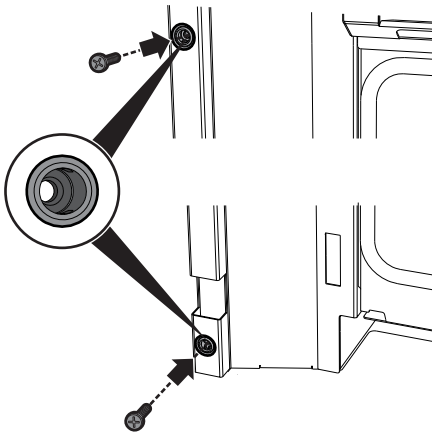

## Appliance overall dimensions (mm)

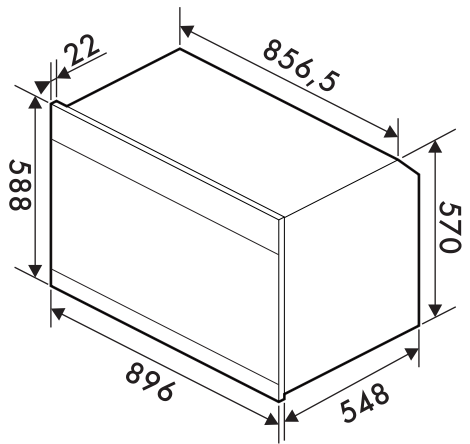



# Installation

### Mounting under worktops (mm)

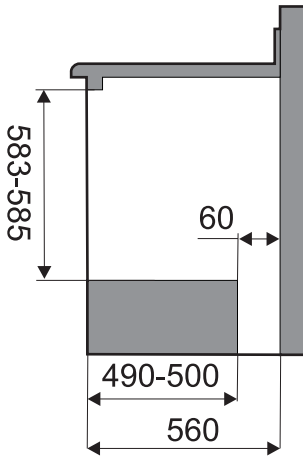
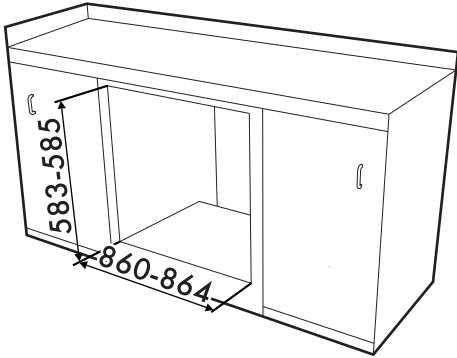

### Mounting into a column (mm)

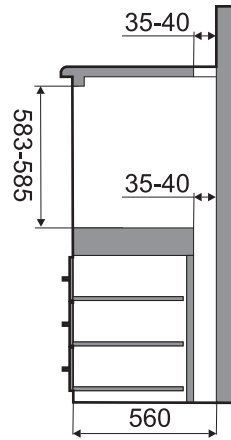
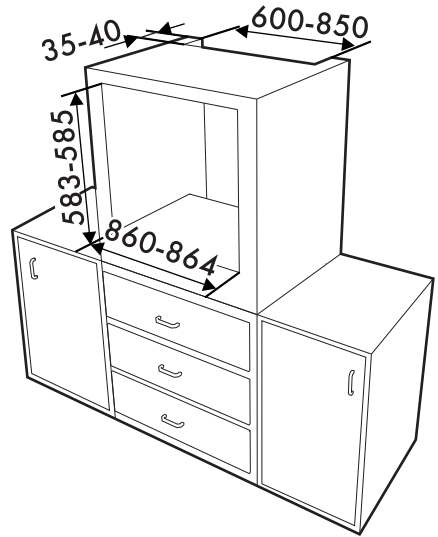

Make sure that the piece of furniture rear/bottom part has an opening of approx. 60 mm.



Make sure that the piece of furniture top/rear part has an opening approx. 35-40 mm deep.







914775316/A