

U2P™

UPA to PCI Interface User's Manual



THE NETWORK IS THE COMPUTER™

A Sun Microsystems, Inc. Business
2550 Garcia Avenue
Mountain View, CA 94043 USA
1-800-681-8845
www.sun.com/sparc
Part No.: 802-7835-01
May 1997

Copyright © 1997 Sun Microsystems, Inc. All Rights Reserved.

THE INFORMATION CONTAINED IN THIS DOCUMENT IS PROVIDED "AS IS" WITHOUT ANY EXPRESS REPRESENTATIONS OR WARRANTIES. IN ADDITION, SUN MICROSYSTEMS, INC. DISCLAIMS ALL IMPLIED REPRESENTATIONS AND WARRANTIES, INCLUDING ANY WARRANTY OF MERCHANTABILITY, FITNESS FOR A PARTICULAR PURPOSE, OR NON-INFRINGEMENT OF THIRD PARTY INTELLECTUAL PROPERTY RIGHTS.

This document contains proprietary information of Sun Microsystems, Inc. or under license from third parties. No part of this document may be reproduced in any form or by any means or transferred to any third party without the prior written consent of Sun Microsystems, Inc.

Sun, Sun Microsystems, and the Sun logo are trademarks or registered trademarks of Sun Microsystems, Inc. in the United States and other countries. All SPARC trademarks are used under license and are trademarks or registered trademarks of SPARC International, Inc. in the United States and other countries. Products bearing SPARC trademarks are based upon an architecture developed by Sun Microsystems, Inc.

The information contained in this document is not designed or intended for use in on-line control of aircraft, air traffic, aircraft navigation or aircraft communications; or in the design, construction, operation or maintenance of any nuclear facility. Sun disclaims any express or implied warranty of fitness for such uses.

Printed in the United States of America.

Contents

1. Overview	1-1
Introduction	1-1
Product Summary	1-2
Technology	1-2
Package	1-2
Design Size	1-2
Custom Cells	1-2
Maximum Frequency of Operation	1-3
Minimum Frequency of Operation	1-3
Power Consumption	1-3
Performance	1-4
Typical System Partition	1-5
U2P External Interfaces	1-5
U2P Block Diagram	1-7
U2P Block Overviews	1-8
UPA Interface blocks	1-8
PCI Interface blocks	1-8
Interrupt block	1-9
Internal Control	1-9
Clock Ratios	1-10
Miscellaneous	1-10
PCI Address Map Overview	1-10

2. U2P Pin Descriptions	2-1
UPA Interface Signals	2-1
64-bit, 66MHz capable PCI Interface Signals (PCI Bus A)	2-2
64-bit, 33MHz PCI Interface Signals (PCI Bus B)	2-3
Miscellaneous Interfaces	2-4
Power and Ground Pins/Pads	2-5
Total Pin/Pad Count	2-6
3. U2P Functional Description	3-1
Functional Overview	3-1
Top-Level Architectural Philosophy	3-1
Block Overviews	3-4
PIO Decoder	3-4
DMA Control	3-4
Bus Control	3-5
UPA Master / Slave	3-5
UPA Reply	3-6
ECC Generate / Check	3-6
DMA Merge Buffer	3-7
PCI Bus Module (PBM)	3-7
IOMMU	3-10
Streaming Cache	3-10
MDU	3-11
Timer / Counters	3-12
Reset	3-12
Testability	3-13
4. DMA/PIO Transactions Flow	4-1
Block Diagram	4-2
DMA Transaction Flow	4-5
DMA Write Transactions	4-6
64 and 16 Byte DMA Writes to IO Space	4-6
64 Byte DMA Write to Memory	4-8
Less than 64 Byte DMA Write to Memory	4-10
DMA Read Transactions	4-13

PIO Transaction Flow 4-14

PIO Write 4-15

PIO Read 4-17

5. IOMMU 5-1

Block Diagram 5-2

TLB Entry Format 5-2

TLB CAM Tag 5-3

TLB RAM Data 5-3

DVMA Operation Modes 5-4

Translation Mode 5-4

Bypass Mode 5-5

Pass-through Mode 5-6

Translation Storage Buffer 5-6

Translation Table Entry 5-7

TSB Lookup 5-7

PIO Operations 5-9

Translation Errors 5-9

IOMMU Demap 5-10

TLB Initialization and Diagnostics 5-10

6. PCI Bus Interface 6-1

Introduction 6-1

Supported PCI features: 6-1

Unsupported PCI features: 6-2

PCI Bus Operations 6-2

Bus Master Operation (PIO) 6-2

Target Operation (DMA) 6-4

Transaction Termination Behavior 6-5

Retries 6-5

Disconnects 6-5

Master-aborts 6-5

Target-aborts 6-6

Addressing Modes 6-7

- Configuration Cycles 6-7
- Special Cycles 6-7
- Exclusive Access 6-8
- Fast Back-to-Back Cycles 6-8
- Functional Topics 6-9
 - PCI Arbiter 6-9
 - Arbitration Scheme 6-9
 - Bus Parking 6-9
 - Endianess 6-10
 - PCI Commands 6-10
 - Diagnostic Modes 6-11
 - Clocks 6-11
 - Reset 6-11

7. Streaming Cache Operation 7-1

- Overview 7-1
 - Streaming Cache Conceptual Overview 7-2
 - STC Subsections 7-2
- Streaming Cache Functional Description 7-3
 - Streaming Writes 7-3
 - Byte Holes and Zero Byte Writes 7-4
 - Streaming Reads 7-4
 - Entry Flushing 7-5
- Streaming Cache Programming Model 7-6
 - Performance Issues 7-6
 - Memory Coherency Maintenance 7-7
 - Error Recovery 7-8

8. Mondo Dispatch Unit 8-1

- Overview 8-1
 - Mondo Dispatch Overview 8-1
 - Mondo Dispatch Block Diagram 8-3
- Mondo Unit Functional Description 8-3
 - Mondo Vectors 8-4

	Overview of an Interrupt	8-4
	Interrupt Number Register	8-5
	Interrupt Types	8-6
	Internal/External	8-6
	Level/Pulse	8-7
	Priority	8-8
	Synchronization with DMA writes	8-9
	Interrupt Table	8-9
	Processing an Interrupt	8-11
	Interrupt Receiver	8-12
	Interrupt Decoder	8-12
	Interrupt Arbiter	8-12
	Interrupt Dispatcher	8-12
9.	U2P Timer/Counter	9-1
	Overview	9-1
	Timer Functional Description	9-2
10.	Little-endian support	10-1
	Big- and Little-endian regions	10-1
	Address Space	10-1
	Internal blocks	10-2
	Byte Twisting	10-2
	Specific Cases	10-4
	PIOs	10-4
	DMA	10-5
11.	Error Handling	11-1
	Overview	11-1
	Fatal Hardware Errors	11-1
	UPA Address Parity Error	11-1
	Non-fatal Hardware Error	11-2
	UPA Datapath Uncorrectable Error	11-2
	UPA Timeout	11-3
	UPA Read Error	11-3

PCI Data Parity Error	11-3
PCI Target-Abort	11-4
PCI Timeout	11-4
DVMA ECC Error	11-5
IOMMU Translation Error	11-5
PCI Address Parity Error	11-5
PCI System Error	11-6
Summary of Error Reporting	11-6
Unreported Errors	11-9

12. JTAG 12-1

Introduction	12-1
TAP Controller	12-2
Synchronous FSM and Decode	12-5
Instruction Register	12-5
Instruction Decode Logic	12-6
Bypass Register	12-6
Internal Register Clocking Logic	12-7
JTAG ID Register	12-7
Boundary Scan Control Logic	12-7
BIST Control Logic	12-7
Clock Control Registers	12-8
Clock Stop Logic	12-8
TDO MUX logic	12-8
Scan Chains	12-9
Boundary Chain	12-9
The Internal Scan Chain	12-9
ATPG Chain	12-10
Special JTAG Instructions	12-10
INTEST	12-10
The ATPG Instruction	12-10
The RUNBIST Instruction	12-11
Test Coverage Information	12-11
ATPG	12-11
BIST	12-12

13. Programmer's Model	13-1
Internal Registers	13-1
U2P Control/Status Register	13-2
UPA Registers	13-4
UPA Port ID Register	13-4
UPA Configuration Register	13-5
ECC Registers	13-6
ECC Control Register	13-6
Uncorrectable Error Asynchronous Fault Status/Address Register	13-7
Correctable Error Asynchronous Fault Status/Address Register	13-9
DMA Scoreboard Diagnostic Support	13-10
PCI Bus Module	13-12
PCI Control/Status Register	13-13
PCI Asynchronous Fault Status/Address Registers	13-14
PCI Diagnostic Register	13-17
PBM Configuration Space	13-18
Vendor ID	13-20
Device ID	13-20
Command Register	13-21
Status Register	13-22
Revision ID Register	13-22
Programming I/F Code Register	13-23
Sub-class Code Register	13-23
Base Class Code Register	13-23
Latency Timer Register	13-23
Header Type Register	13-24
Bus Number	13-24
Subordinate Bus Number	13-24
Unimplemented Registers	13-24
IOMMU Registers	13-25
IOMMU Control Register	13-25
TSB Base Address Register	13-28
Flush Address Register	13-29
TLB TAG Diagnostics Access	13-29

TLB Data RAM Diagnostic Access	13-30
LRU Queue Diagnostic Access	13-31
Virtual Address Diagnostic Register	13-31
TLB Tag Compare Diagnostic Access	13-32
Streaming Buffer Registers	13-33
Streaming Buffer Control Register	13-34
Streaming Buffer Page Invalidate/Flush Register	13-35
Streaming Buffer Flush Synchronization Register	13-35
Streaming Buffer Page Tag Diagnostic Access	13-36
Streaming Buffer Line Tag Diagnostic Access	13-36
Streaming Buffer Data RAM Diagnostic Access	13-37
Streaming Buffer Error Status Diagnostic Access	13-37
Interrupts	13-38
Partial Interrupt Mapping Registers	13-40
Full Interrupt Mapping Registers	13-42
Clear Interrupt Registers	13-43
Interrupt State Diagnostic Registers	13-45
Interrupt Retry Timer Register	13-48
Counter/Timer Registers	13-49
Count Registers	13-49
Limit Registers	13-50
Performance Monitor Registers	13-50
Performance Monitor Control Register	13-51
Performance Counter Register	13-53
PCI Address Spaces	13-53
UPA to PCI	13-53
PCI Configuration Space	13-54
Special Cycles	13-56
PCI I/O Space	13-56
PCI Memory Space	13-56
PCI to UPA	13-57
PCI Configuration Space	13-57
PCI I/O Space	13-57
PCI Memory Space	13-57
Address Map Summary	13-59

Figures

Typical PCI UltraSPARC System Block Diagram 1-5

U2P External Interfaces 1-6

U2P Conceptual Block Diagram 1-7

U2P PIO and DVMA address spaces 1-11

PIO Data & Address Paths 3-2

DMA Data & Address Paths 3-3

Top level block diagram for DMA and PIO transactions flow/control 4-2

DMA Write to IO space 4-6

64 Bytes DMA Writes to Memory 4-8

Less than 64 Bytes DMA Writes to Memory 4-10

DMA read request to memory or IO space 4-13

PIO Write Transaction Flow 4-15

PIO Read Transaction Flow 4-17

IOMMU top level block diagram 5-2

Virtual to physical address translation for 8K page size 5-5

Virtual to physical address translation for 64K page size 5-5

Physical address formation in bypass mode (8K and 64K) 5-5

Physical address formation in pass-through mode (8k and 64K) 5-6

Computation of TTE Entry Address 5-8

Basic PCI Read Transaction 6-3

Basic PCI Write Transaction 6-3

Retry Cycle 6-5

Disconnect Cycle 6-6

Master-abort Cycle 6-6

Target-abort Cycle 6-7

Special Cycle 6-8

Fast Back-to-Back Cycles 6-9

Mondo Dispatch Unit in U2P 8-2

Mondo Dispatch Overview Block Diagram 8-3

Mondo Vector Format on UPA Data Bus 8-4

Full INR Contents 8-5

Partial INR Contents 8-6

Level Interrupt States 8-8

U2P Byte Twisting 10-3

TAP Controller Block Diagram 12-2

U2P Data registers 12-3

JTAG control signals during ATPG instruction 12-11

Legal DVMA address configurations 13-27

U2P Interrupt Format 13-38

Type 0 Configuration Address Mapping 13-55

Type 1 Configuration Address Mapping 13-55

Tables

U2P Absolute Best Case Performance 1-4

UPA Interface Signals 2-1

PCI Bus A signals 2-2

PCI Bus B Signals 2-3

Miscellaneous Signals 2-4

Power and ground pins 2-5

Special power and ground pins 2-5

Total Pin Count 2-6

Type of P_REQ and S_REPLY used for DMA write to IO space 4-7

Type of S_REPLY's U2P receives 4-7

Type of P_REQ and S_REPLY used for 64 byte DMA writes to memory 4-9

Type of P_REQ and S_REPLY used for less than 64 byte DMA writes 4-11

Type of P_REQ and S_REPLY used for DMA reads 4-14

Type of write P_REQ's U2P receives and type of P_REPLY it generates 4-16

Type of P_REPLY's generated by U2P 4-16

Type of read P_REQ's U2P receives and type of P_REPLY it generates 4-18

Description of TLB Tag Fields 5-3

TLB Data Format 5-3
PCI DVMA Modes of Operation 5-4
TTE Data Format 5-7
Offset to TSB Table 5-8

PCI Command Generation and Response 6-10

Level Interrupt States 8-7
Interrupt Receiver State Register 8-8
Summary of Interrupts 8-10

Summary of Fatal Error Reporting 11-6
Summary of Non-Fatal Error Reporting 11-7

Description of signals in JTAG macro 12-3
Components of the U2P TAP controller 12-4
Instructions supported by U2P JTAG controller 12-5
U2P scan chains 12-9
BIST register files 12-12
Non-BIST register files 12-13

Offset of Control Register 13-2
U2P Control Register 13-2
Offset of UPA Registers 13-4
UPA Port ID Register 13-4
UPA Configuration Register 13-5
Offset of ECC Registers 13-6
ECC Control Register 13-6
ECC Error Reporting 13-7
UE AFSR 13-8

UE AFAR 13-8
CE AFSR 13-9
CE AFAR 13-10
Offset of DMA Scoreboard Diagnostic Access 13-10
DMA Scoreboard Diagnostic Access 13-11
Offset of PBM Registers 13-12
PCI Control and Status Register 13-13
PCI AFSR 13-15
PCI AFAR 13-16
PCI Diagnostic Register 13-17
Default offset of PCI Bridge Configuration Spaces 13-18
Configuration Space Header Summary 13-19
Command Register 13-21
Status Register 13-22
Latency Timer Register 13-23
Header Type Register 13-24
Offset of IOMMU Registers 13-25
IOMMU Control Register 13-25
Address space size and base address determination 13-26
TSB Base Address Register 13-28
Flush Address Register 13-29
TLB Tag Diagnostics Access 13-29
TLB Data RAM Diagnostics Access 13-30
LRU Entry Diagnostics Access 13-31
Virtual Address Diagnostic Register 13-31
TLB Tag Comparator Diagnostics Access 13-32
Offset of Streaming Buffer Registers 13-33
Streaming Buffer General Control Register (2 copies) 13-34
Streaming Buffer Page Invalidate/Flush Register (2 copies) 13-35

Streaming Buffer Flush Synchronization Register (2 copies) 13-35

Streaming Buffer Page Tag Format 13-36

Streaming Buffer Line Tag Format 13-36

Streaming Buffer Data RAM Content Format 13-37

Streaming Buffer Data RAM Error Format 13-37

Interrupt Number Offset Assignments 13-39

Offset of Partial Interrupt Mapping Registers 13-40

Format of Partial Interrupt Mapping Registers 13-42

Offset of Full Interrupt Mapping Registers 13-42

Format of Full Interrupt Mapping Registers 13-43

Offset of Clear Interrupt Pseudo Registers 13-43

Clear Interrupt Register 13-45

Offset of Interrupt State Diagnostic Registers 13-45

Level Interrupt State Meaning 13-46

Pulse Interrupt State Meanings 13-46

PCI Int Diag Reg Definition 13-46

OBIO and Misc Int Diag Reg Definition 13-47

Offset of Interrupt Retry Timer Registers 13-48

Interrupt Retry Timer Register 13-48

Offset of Counter/Timer Registers 13-49

Count Register 13-49

Limit Register 13-50

Offset of Performance Monitor Registers 13-50

Performance Monitor Control Register 13-51

Performance Counter Event Sources 13-51

Performance Counter Register 13-53

Offsets for access from UPA space to PCI space 13-53

PCI DVMA Modes of Operation 13-58

Address Map Summary 13-59

Overview

1.1 Introduction

The U2P chip is the primary connection on an UltraSPARC CPU board between the UPA System Bus (including UltraSPARC Processors and Memory) and a PCI based I/O Subsystem. U2P features include:

- Full master and slave port connection to the high-speed UltraSPARC UPA Interconnect. The UPA is a split address/data packet-switched bus which has a potential data throughput rate of over 1 Gbyte/sec. UPA data is ECC protected.
- Two physically separate PCI bus segments, with full master and slave support.

PCI Bus A has the following features:

- 5 volt or 3.3 volt signalling.
- 64-bit data bus.
- Compatible with the PCI Rev 2.1 Specification.
- Compatible with the PCI 66MHz extensions.
- Support for up to four master devices (at 33MHz only).

PCI Bus B has the following features:

- 5 volt signalling.
- 64-bit data bus.
- Compatible with the PCI Rev 2.1 Specification.
- Support for up to six master devices.
- Two separate 16-entry streaming caches, one for each bus segment, for accelerating some kinds of PCI DVMA activity. Single IOMMU with 16-entry TLB for mapping DVMA addresses for both busses.

- A “Mondo-Vector” Dispatch Unit, or MDU, for delivering Interrupt requests to UltraSparc CPU modules, including support for PCI interrupts from up to six total slots, as well as interrupts from on board IO devices.

1.2 Product Summary

1.2.1 Technology

- 0.35 micron, 3 level metal, 3.3 volt optimized CMOS standard cell library from Lucent Technologies (formerly AT&T).

1.2.2 Package

- The U2P die has 352 signal pads (including specialty power/grounds) and 104 VSS/VDD pads for a total pad count of 456.
- The U2P package is a 456 ball PBGA, with 352 signal balls and 104 VSS/VDD balls.

1.2.3 Design Size

- 170K gates.
- 29K bits RAM.
- Die size = 404.7 x 435.4 mils (10280 x 11060 microns)

1.2.4 Custom Cells

The following non-standard cells are used in the U2P chip design:

- 5V tolerant PCI pads.
- 66MHz capable PCI pads.
- UPA pads (with and without holding amps).
- PLL and PECL receiver for UPA clock.
- PLL for main clock.

1.2.5 Maximum Frequency of Operation

- UPA operation (UPACLK) up to 100 MHz (10 ns).
- Main internal clock (PSYCLK) up to 66.7 MHz (15 ns).
- PCI bus A clocks at 1x or 0.5x internal clock (synchronous).
- PCI bus B clocks at 0.5x internal clock (synchronous).

1.2.6 Minimum Frequency of Operation

At times it is desirable to run the clocks at less than their intended frequencies. For reliable operation, certain ratios between UPACLK and PSYCLK must be maintained.

- $UPACLK > 0.9 * PSYCLK$ if Mode bit = 1 (Control/Status Reg bit 0).
- $PSYCLK > 0.41 UPACLK$

1.2.7 Power Consumption

- Maximum power consumption: 3 Watts.

1.3 Performance

The performance numbers in the table below were extracted from simulations. For PIO and Consistent DMA, 16 back-to-back transactions were simulated, the first 4 were ignored, and the remaining ones were timed. For Streaming DMA, 64 back-to-back transactions were simulated and the first 16 ignored.

Table 1-1 U2P Absolute Best Case Performance

Xfer Size	Bus speed	Bus Width	PIO Wr	PIO Rd ¹	DMA Wr Consistent	DMA Rd Consistent	DMA Wr Streaming	DMA Rd Streaming
4	33 MHz	32 bit	22.2	8.3	10.3	7.7	22.5	24.2
16	33 MHz	32 bit	59.3	26.7	40.3	27.9	61.0	53.3
64	33 MHz	32 bit	97.0	66.7	106.7	71.1	106.7	106.7
8	33 MHz	64 bit	----	----	19.5	15.8	45.4	44.6
16	33 MHz	64 bit	----	----	39.5	29.6	79.0	59.3
64	33 MHz	64 bit	----	----	177.8	94.1	177.8	164.1
4	66 MHz	32 bit	33.3	11.1	10.1	8.6	33.6	33.3
16	66 MHz	32 bit	106.7	38.1	40.0	33.3	99.2	76.2
64	66 MHz	32 bit	185.5	103.2	193.9	106.7	193.9	185.5
8	66 MHz	64 bit	----	----	19.6	17.4	67.7	59.3
16	66 MHz	64 bit	----	----	40.5	34.3	121.9	82.1
64	66 MHz	64 bit	----	----	304.8	125.5	304.8	222.1
All performance measurements are in MBytes/sec.								

1. The PIO read performance numbers shown here are not absolute best case numbers. Simulations were run with only a single outstanding PIO read allowed. In systems where multiple outstanding PIO reads are supported, somewhat higher PIO read performance numbers are possible.

Caution – Except where noted, the table above lists the maximum achievable performance for the U2P chip. These are not minimum or typical performance numbers. Many factors can reduce the above performance numbers, including but not limited to: (1) System clock speed; (2) Contention for memory or UPA bus; (3) Specific SC implementation details; (4) IOMMU tablewalks, or thrashing in the IOMMU or streaming cache; (5) Insertion of wait-states by PCI device (as master or slave); (6) Software overhead.

1.4 Typical System Partition

Figure 1-1 shows one possible configuration of U2P in a PCI UltraSPARC system. U2P connects to the system controller chip and other UPA ports via UPA address, control and data busses. The system has both PCI and EPCI slots, as well as an on board PCI device (PCIO). Interrupt information is provided by the RIC chip, and a JTAG port is provided for board test as well as in-circuit test and debug of U2P.

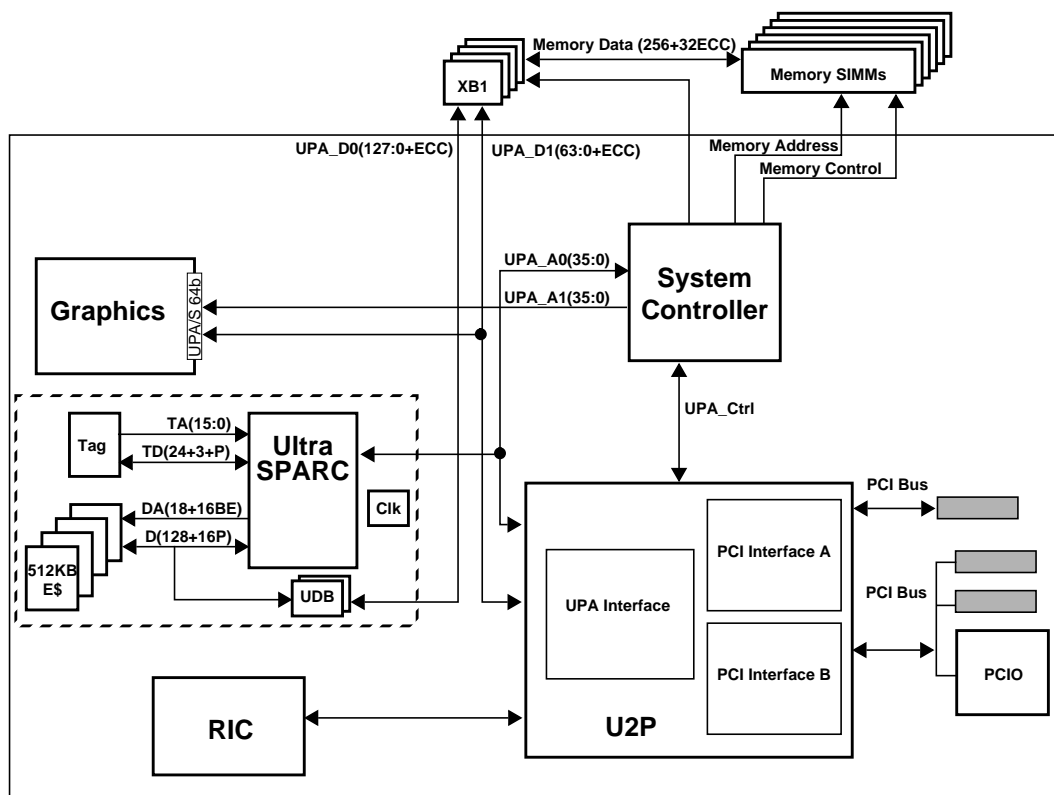

Figure 1-1 Typical PCI UltraSPARC System Block Diagram

1.5 U2P External Interfaces

Figure 1-2 summarizes the external interfaces and pins of U2P.

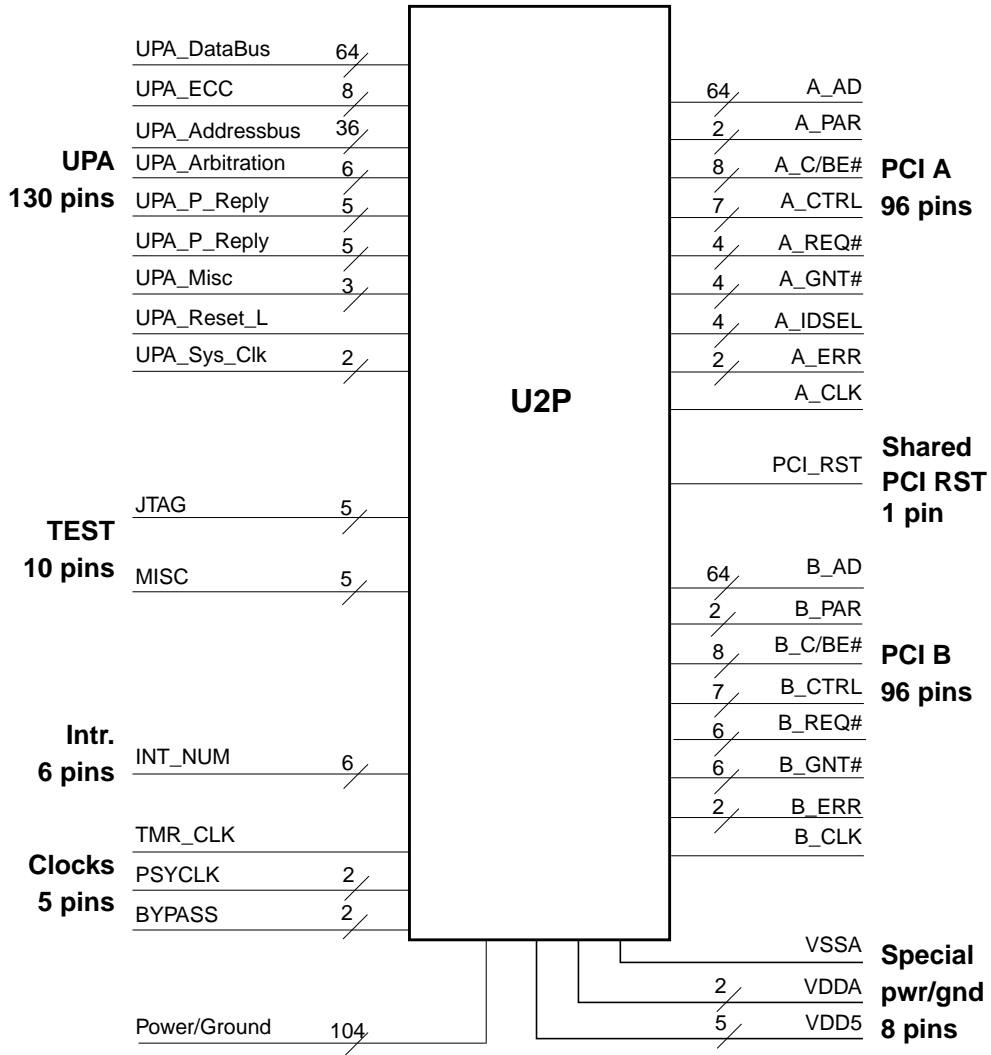

Figure 1-2 U2P External Interfaces

1.6 U2P Block Diagram

The diagram below shows a conceptual block diagram of U2P. The actual implementation is somewhat different, for example, there are no internal bidirectional busses. Details of specific implementation of each block can be found in the following chapters.

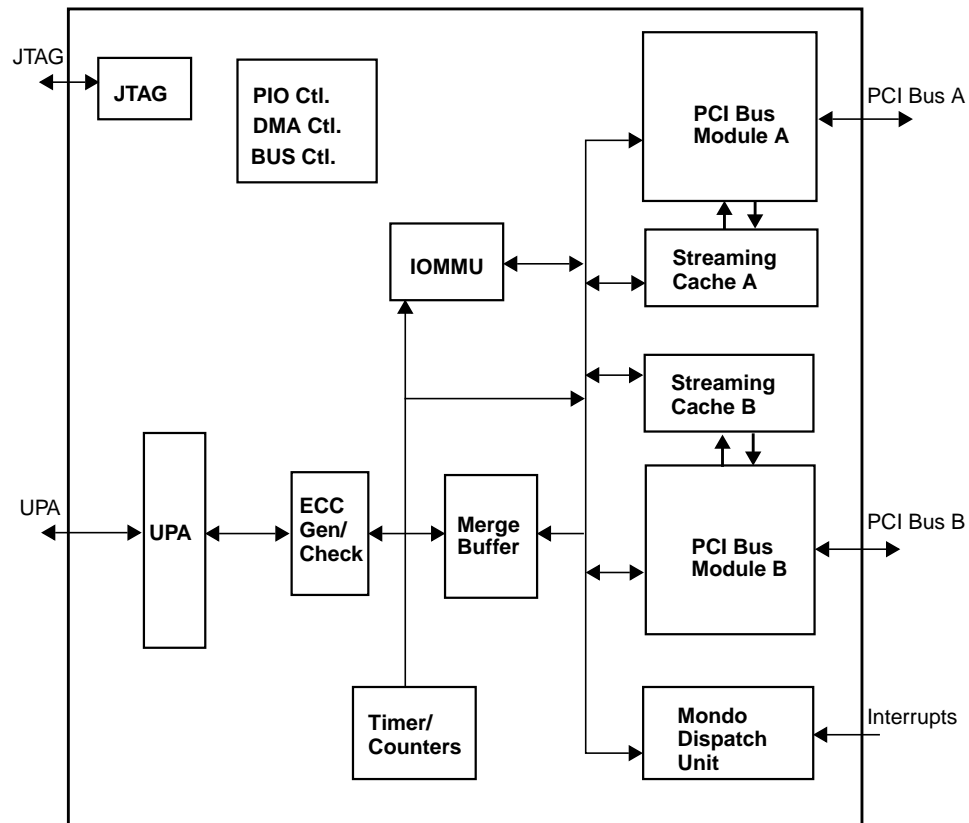

Figure 1-3 U2P Conceptual Block Diagram

1.7 U2P Block Overviews

This section gives a brief description of each top level functional block. A more detailed description of each block can be found in Chapter 3. Each block is also described in its own individual chapter as well. The top level blocks in U2P fall into one of five categories:

- UPA.
- PCI.
- Interrupt.
- Internal Control.
- Miscellaneous.

1.7.1 UPA Interface blocks

The UPA is UltraSPARC system's packet switched main system bus. In an UltraSPARC system, the UPA can operate up to 100 MHz. Data and address have independent flow controls. Each type of UPA cycle (PIO read, PIO write, DMA read, etc.) uses its own FIFO-based queueing. There is a synchronization boundary between the UPA interface blocks and other U2P blocks, which run at 66.7 MHz.

- **UPA Master/Slave:** This block deals exclusively with UPA address control. It listens to UPA_A when U2P is a slave. It also arbitrates for and drives UPA_A when U2P is a master.
- **UPA_Reply:** This block deals exclusively with UPA data. It generates P_REPLY to the System Controller (SC) ASIC during PIO and copyback cycles. It also listens to S_REPLY from the SC and manages the UPA data FIFOs accordingly.
- **ECC Generate:** Generates ECC on the outgoing 64-bit UPA data path.
- **ECC Check:** Checks ECC on the incoming 64-bit UPA data path.

1.7.2 PCI Interface blocks

- **PCI Bus Module (PBM):** This is the main portion of the PCI interface. U2P contains two nearly identical copies of this block. One is designed to support a 64-bit PCI bus at 66 MHz or 33 MHz with up to four master devices. The other supports a 64-bit PCI bus at 33MHz with up to six master devices. The PBM adheres to all PCI protocol guidelines as contained in the PCI Revision 2.1

specification. Each PBM controls arbitration, flow control and error handling for its bus segment. Each PBM also handles the big- to little-endian byte twisting required for correct operation of both PIO and DVMA datapaths.

- **IOMMU:** For the portion of the PCI memory address space which is reserved for DMA to the UPA bus, the IOMMU maps the PCI address into the appropriate UPA physical address. The IOMMU keeps the 16 most recently used translations in a TLB, and automatically performs hardware tablewalks on TLB misses. There is a single IOMMU supporting both PCI busses. Only a single translation can be in progress at a time, and during tablewalks, translations from the other bus segment will be delayed.
- **Streaming Cache:** The Streaming Cache (STC) is used to accelerate PCI DMA activity. For DMA reads, the STC will speculatively prefetch 64-byte cache lines. For DMA writes, the STC buffers up 64-byte lines before sending to the UPA interface. There are two separate STC blocks in U2P, one associated with each PBM block. Each STC contains storage for 16 virtual address tagged entries and their data, which is stored in 64-byte lines, allocated on a least recently used basis.

1.7.3 Interrupt block

- **Mondo Dispatch Unit (MDU):** In the Sun-4U architecture, interrupts to a processor are sent as packets on the UPA bus. The MDU in U2P is a system resource for generating such packets. The MDU accepts interrupt requests from the UPA slave ports, PCI busses and internal U2P sources and dispatches interrupt packets to the UPA.

1.7.4 Internal Control

- **Merge Buffer:** In order to allow sub-line writes into a 64-byte memory line, it is necessary to perform a read-modify-write operation on the UPA. The Merge Buffer is responsible for generating the correct UPA read, merging the partial line, and writing the whole block to the UPA.
- **PIO Control:** Decodes slave requests from the UPA_A request FIFO, arbitrates for the appropriate resource and dispatches the request.
- **Bus Control:** This is an internal arbiter shared by the PIO Control and DMA Control blocks. It schedules the use of the main internal data paths.
- **DMA Control:** Arbitrates and decodes requests from internal DMA sources (PBM, STC, IOMMU, MDU), and arbitrates for the appropriate UPA FIFO.

1.7.5 Clock Ratios

At times it is desirable to run the clocks at less than their intended frequencies. Such instances might be using the part in a low speed emulation environment, or if on power up the clocks are defaulted to something other than their usual speed.

There are two ratios that must be adhered to:

- $UPACKL > 0.9 * PSYCLK$ if Mode bit = 1 (Control/Status Reg bit 0).
Prevents underrunning the UPA input FIFO which could occur if UPACKL is running too slow in relation to PSYCLK.
- $PSYCLK > 0.41 UPACKL$.
Prevents underrunning the DMA write data FIFO which could occur if PSYCLK is running too slow in relation to UPACKL.

Note that it is clock ratios which are being specified here and not a minimum operating frequency. U2P has been used in emulation at speeds in the 1KHz range.

1.7.6 Miscellaneous

- **Timer/Counter:** Contains two identical 32-bit timer-counters as specified by the Sun-4U architecture. Used for system scheduling and profiling.
- **JTAG Control:** Provides the necessary control for the standard IEEE 1149.1 JTAG port, as well as additional scan based features that are useful for debugging purposes.

1.8 PCI Address Map Overview

Complete information on address maps and other software visible features of U2P can be found in Chapter 13. A simplified diagram showing PIO and normal DVMA address spaces is in Figure 1-4.

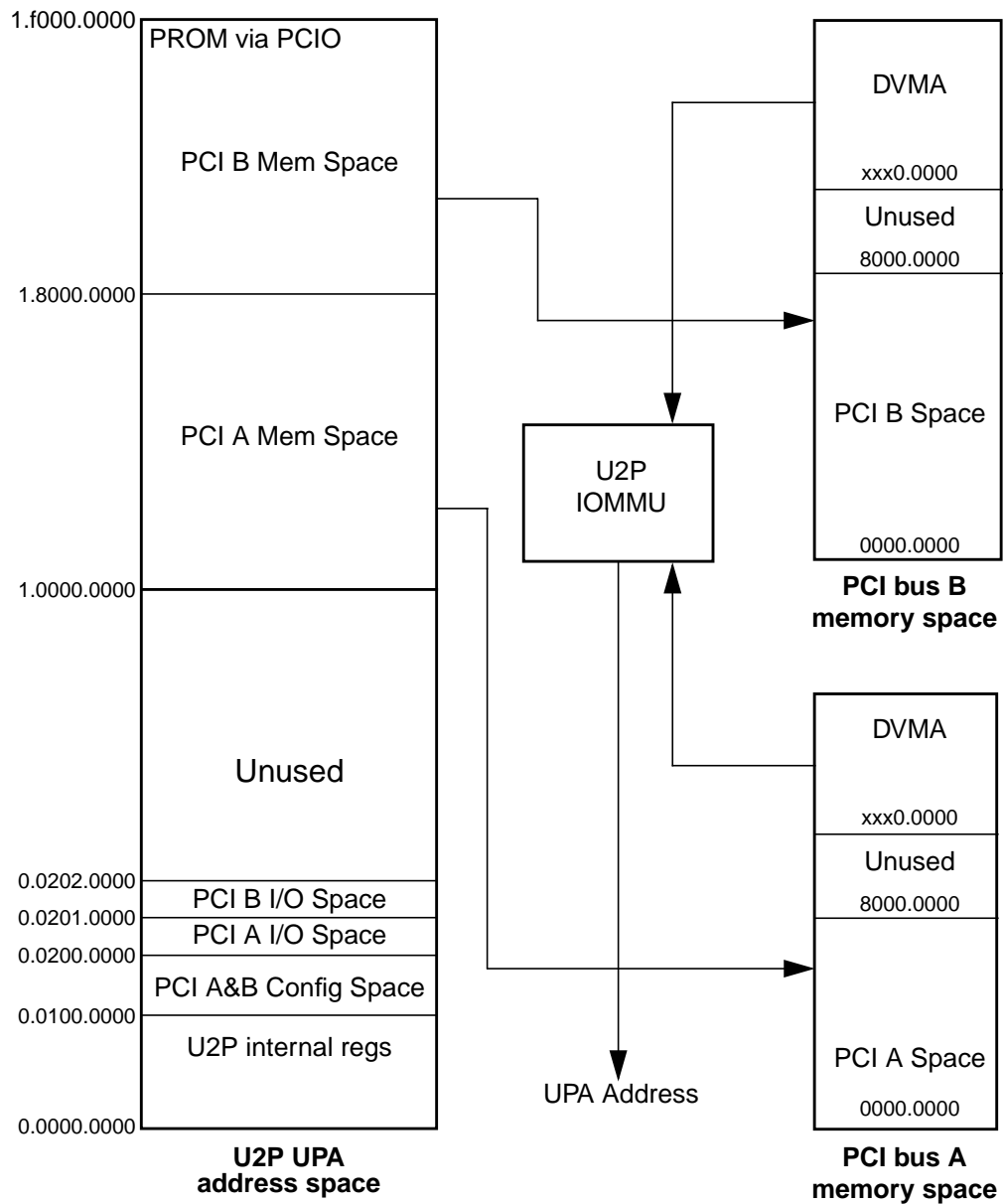

Figure 1-4 U2P PIO and DVMA address spaces

U2P Pin Descriptions

2.1 UPA Interface Signals

These signals connect U2P to the UPA. Maximum frequency of operation is 100 MHz.

Table 2-1 UPA Interface Signals

Signal Name	Pin Count	I/O	Description
UPA_DataBus	64	I/O	64 bit Data Bus
UPA_ECC	8	I/O	8 bits for ECC
UPA_Addressbus	36	I/O	Address/request lines + parity
UPA_Req_in	3	I	Requests from other clients on this address bus
UPA_Req_out	1	O	Request asserted by U2P
UPA_SC_Req_in	1	I	Request from the SC
UPA_Arb_Reset_L	1	I	UPA Arbiter reset
UPA_Addr_Valid	1	I/O	Valid address; active high
UPA_ECC_Valid	1	I	ECC Valid
UPA_Data_Stall	1	I	Data Stall
UPA_P_Reply	5	O	Port Reply signals
UPA_S_Reply	5	I	System Reply signals

Table 2-1 UPA Interface Signals (Continued)

Signal Name	Pin Count	I/O	Description
UPA_Reset_L	1	I	Port/System Reset Signal
UPA_Sys_Clk_pos UPA_Sys_Clk_neg	2	I	UPA System Clock (PECL)
UPA Total	130		

2.2 64-bit, 66MHz capable PCI Interface Signals (PCI Bus A)

These signals connect U2P to the 64-bit, 66MHz capable PCI bus segment. Maximum frequency of operation is 66.7 MHz.

Table 2-2 PCI Bus A signals

Signal Name	Pin Count	I/O	Description
A_AD<63:0>	64	I/O	Address/Data Bus
A_PAR	1	I/O	Parity for AD<31:0>
A_PAR64	1	I/O	Parity for AD<63:32>
A_CBE_<7:0>	8	I/O	Command/Byte enable lines
A_FRAME_	1	I/O	Cycle frame
A_REQ64_	1	I/O	Request 64-bit transfer
A_ACK64_	1	I/O	Acknowledge 64-bit transfer
A_TRDY_	1	I/O	Target Ready
A_IRDY_	1	I/O	Initiator Ready
A_STOP_	1	I/O	Target initiated STOP
A_DEVSEL_	1	I/O	Target decoded its address
A_IDSEL<3:0>	4	O	Chip select lines for configuration cycles
A_PERR_	1	I/O	Parity Error
A_SERR_	1	I/O	System Error
A_CLK	1	I	PCI Clock

Table 2-2 PCI Bus A signals (Continued)

Signal Name	Pin Count	I/O	Description
A_REQ_<3:0>	4	I	Bus master request lines
A_GNT_<3:0>	4	O	Bus master grant lines
PCI_RST_	1	I	Reset (shared with PCI bus B)
PCI Bus A total	97		

2.3 64-bit, 33MHz PCI Interface Signals (PCI Bus B)

These signals connect U2P to the 32-bit PCI bus segment. Maximum frequency of operation is 33.3 MHz.

Table 2-3 PCI Bus B Signals

Signal Name	Pin Count	I/O	Description
B_AD<63:0>	64	I/O	Address/Data Bus
B_PAR	1	I/O	Parity for AD<31:0>
B_PAR64	1	I/O	Parity for AD<63:32>
B_CBE_<7:0>	8	I/O	Command/Byte enable lines
B_FRAME_	1	I/O	Cycle frame
B_REQ64_	1	I/O	Request 64-bit transfer
B_ACK64_	1	I/O	Acknowledge 64-bit transfer
B_TRDY_	1	I/O	Target Ready
B_IRDY_	1	I/O	Initiator Ready
B_STOP_	1	I/O	Target initiated STOP
B_DEVSEL_	1	I/O	Target decoded its address
B_PERR_	1	I/O	Parity Error
B_SERR_	1	I/O	System Error
B_CLK	1	I	PCI Clock
B_REQ_<5:0>	6	I	Bus master request lines

Table 2-3 PCI Bus B Signals (Continued)

Signal Name	Pin Count	I/O	Description
B_GNT_<5:0>	6	O	Bus master grant lines
PCI_RST_	0	I	Reset (shared with PCI bus A)
PCI Bus B total	96		

2.4 Miscellaneous Interfaces

Clocks, interrupts, JTAG interface, and other test pins.

Table 2-4 Miscellaneous Signals

Signal Name	Pin Count	I/O	Description
PSYCHOPS_CLK	1	I	66 MHz main clock
PSYCHOPS_CLKR	1	I	Reference pin for PSYCHOPS_CLK
PSY_BYPASS	1	I	Bypass PLL on PSYCHOPS_CLK
UPA_BYPASS	1	I	Bypass PLL on UPA_Sys_Clk
TMR_CLK	1	I	10 MHz timer/counter clock
INT_NUM	6	I	Encoded interrupt number
BOOT_BUS	1	I	Select PCI bus A or B for system boot path
EXT_EVENT	1	I	External event trigger
INT_EVENT	1	O	Internal event trigger
B_CPU_REQ	1	O	Test signal - copy of PBMB internal request
B_CPU_GNT	1	O	Test signal - copy of PBMB internal grant
JTAG	5	I/O	JTAG test port
Misc. total	21		

2.5 Power and Ground Pins/Pads

Each signal pin (or ball) is directly connected to a pad on the U2P die. Power and ground pins are connected to power and ground planes on the package substrate. Power and ground pads on the die are connected to these planes as well, but there is no 1-1 correspondence between power/ground pads and pins.

Table 2-5 Power and ground pins

Signal Name	Pad Count	Pin Count	Description
VDD	52	32	3.3V power supply
VSS	52	72	Digital ground
Power total	104	104	

In addition to the main power and ground pins, U2P has some special purpose power and ground pins. These are treated as signal pads/balls, and there is no special handling on the package substrate.

Table 2-6 Special power and ground pins

Signal Name	Pad Count	Pin Count	Description
VDD5	5	5	5V reference voltage
VDDA	2	2	3.3V analog supply
VSSA	1	1	Analog ground
Special total	8	8	

2.6 Total Pin/Pad Count

Table 2-7 Total Pin Count

Interface	Pad Count	Pin Count
UPA	130	130
PCI Bus A	97	97
PCI Bus B	96	96
Miscellaneous	21	21
Special Power/Ground	8	8
Subtotal	352	352
Power/Ground	104	104
Total Count	456	456

U2P Functional Description

3.1 Functional Overview

This chapter contains the functional description of the U2P chip at the top level. Overall chip design is discussed and the address data/flow is presented. This chapter has 2 major sections:

- Block diagrams of the address and data paths.
- A description of each of the major design blocks within U2P.

3.2 Top-Level Architectural Philosophy

When reviewing the U2P internal bus structure, it is important to keep in mind the architectural philosophy of the chip:

- U2P has a UPA bus.
- U2P has two PCI busses.
- The design connects them together so that data goes as fast as possible without making the chip too complicated.
- Where practical, the UPA to SBus (U2S) chip design has been leveraged.

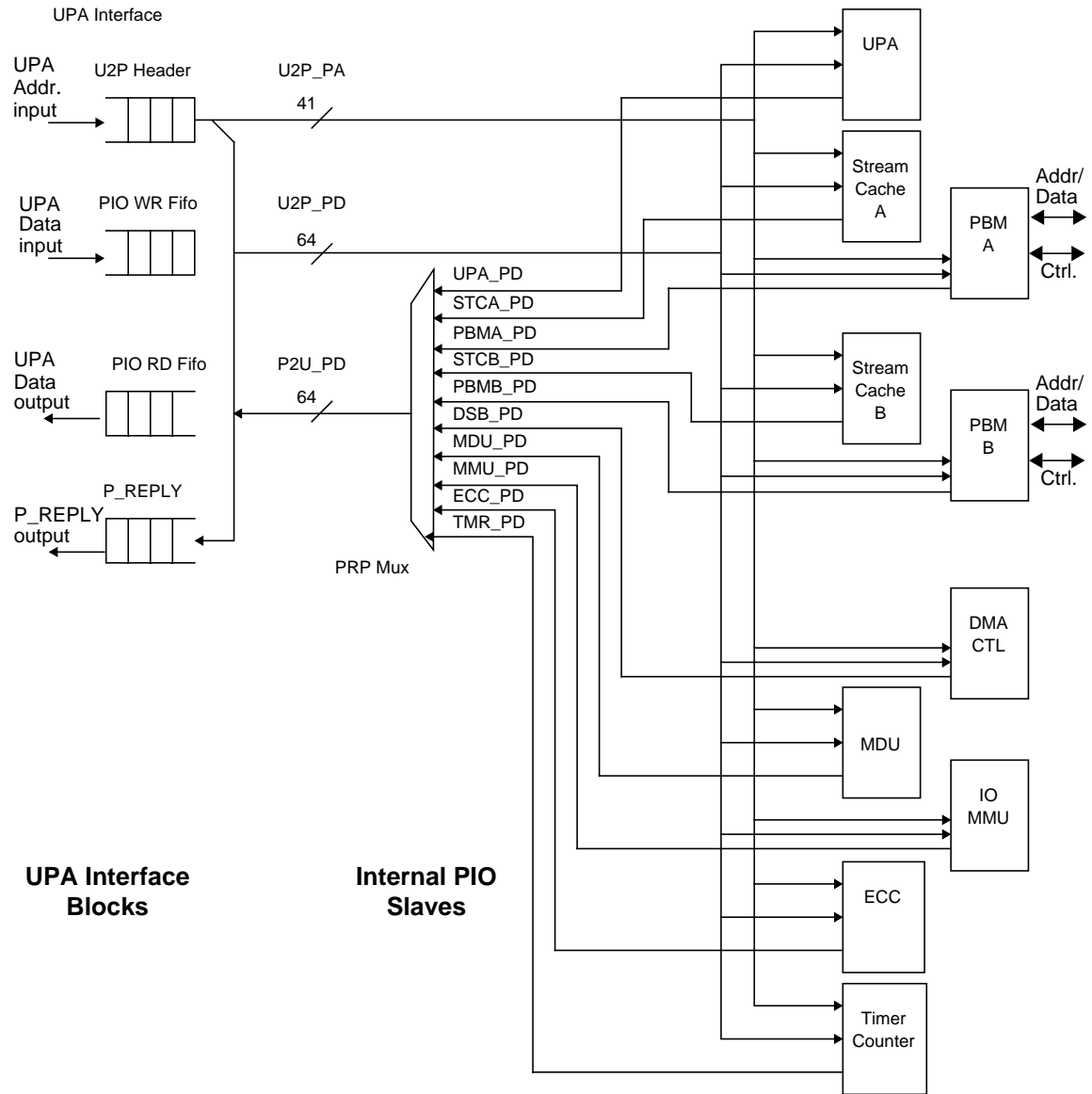

Figure 3-1 PIO Data & Address Paths

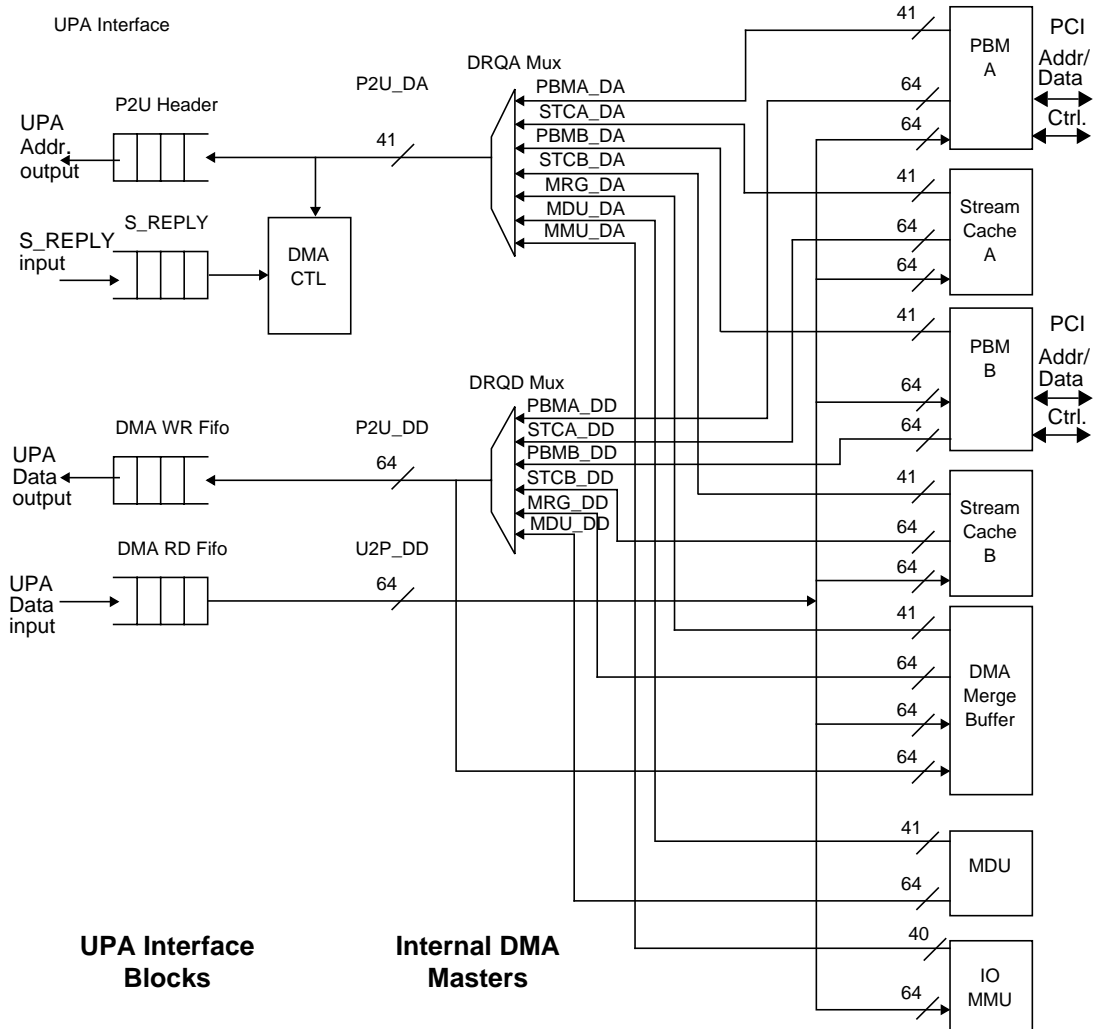

Figure 3-2 DMA Data & Address Paths

3.3 Block Overviews

3.3.1 PIO Decoder

This block decodes requests from the U2P header request FIFO. The target of the PIO cycle may be either PCI bus or one of the internal U2P units. For PCI, the corresponding PBM will determine the transaction timing based on the response of the PCI device. For internal units, the PIO Decoder and Bus Controller block control the timing. All PIO requests are serviced strictly in order and one at a time.

For PIO accesses to PCI configuration space, the PIO Decoder does not have enough information to determine which PBM receives the transaction. With the help of the Bus Controller block, the PIO Decoder will forward the request to both PBM modules. Based on the values programmed into the Bus Number and Subordinate Bus Number registers in each PBM, one or none of the PBM's will accept the PIO, and the Bus Control unit will correctly handle the situation.

The PIO decoder allows the following transaction types:

- P_NCBRD_REQ, P_NCBWR_REQ - Only to PCI memory space portion of address space, not to U2P internal address space or PCI config or PCI I/O space.
- P_NCRD_REQ - With byte masks representing 1, 2, 4, or 8-byte aligned accesses to any U2P internal register.
- P_NCRD_REQ - With byte masks representing 1, 2, or 4-byte aligned accesses to PCI I/O or PCI Configuration space.
- P_NCRD_REQ - 1, 2, 4, 8, or 16-byte accesses are allowed to PCI memory space.
- P_NCWR_REQ - 8-byte accesses are allowed to U2P internal registers (less than 8-byte access is allowed, but treated as 8 bytes).
- P_NCWR_REQ - 4-byte or less accesses are allowed to PCI I/O or PCI Configuration Space.
- P_NCWR_REQ - Any arbitrary byte mask is allowed to PCI memory space.

3.3.2 DMA Control

This block decodes and builds the UPA packet for requests from PCI bus A or B, streaming cache A or B, the IOMMU, the Mondo Dispatch Unit or the Merge Buffer. This block also keeps a FIFO of the requests. All DMA transactions are issued on the UPA with the class bit set to 0, so the UPA will service U2P DMA requests in order. U2P is capable of generating the following transaction types:

- P_NCBRD_REQ, P_NCBWR_REQ - From PBM blocks only.
- P_NCWR_REQ - From PBM block only, may have arbitrary byte mask.
- P_RDO_REQ, P_WRB_REQ - From merge buffer for partial line DMA writes.
- P_RDD_REQ - From PBM, STC or IOMMU.
- P_WRI_REQ - From PBM or STC.
- P_INT_REQ - From Mondo Dispatch Unit.

3.3.3 Bus Control

This is an internal arbiter shared between the DMA Control and PIO Control units. The bus control unit handles timing of internal U2P resources based on the number of clocks required for each kind of transaction. The bus control unit correctly handles “ambiguous” PIO destinations (i.e. PIO’s to PCI configuration space, in which either or none of the PBM blocks may respond).

There are separate busses for each of the following operations: PIO read, PIO write, DMA read and DMA write. The PIO read and write busses are considered a single resource by the bus controller, so only one PIO operation is in progress at a time. The remaining busses are independent, however, so the bus controller allows a PIO operation, a DMA read, and a DMA write all to be in progress at the same time.

The bus controller also handles allocation of the merge buffer. A DMA write that requires the merge buffer is held off until it is available. Once the merge buffer is allocated, the bus controller will not allow any other DMA operation to be initiated until the merged data is written back to the UPA.

3.3.4 UPA Master / Slave

The UPA Master / Slave (UMS) block is U2P’s interface to the UPA_A request bus. When U2P is addressed as a UPA slave (PIO requests), the UMS always writes the request into the U2P Header FIFO.

When U2P is performing a DMA request, the UMS arbitrates for use of the UPA_A bus and drives the request out from the P2U Header FIFO.

As with the UPA Reply block, the UMS runs at the UPA clock frequency, up to 100 Mhz. Signals from other internal U2P blocks are 2-clock synchronized by the UMS before being used. Likewise, status and control which is an output of the UMS block is 2-clock synchronized with the U2P main clock (66.7 Mhz) before being used.

3.3.5 UPA Reply

The UPA Reply unit manages replies to the system controller. P_REPLY requests are received from the PIO Control Unit and forwarded to the UPA bus. For PIO reads, P_REPLY indicates that U2P has read data ready in the PIO_RD FIFO. For PIO writes, P_REPLY indicates that U2P has removed write data from the PIO_WR FIFO. P_REPLY is not used for DMA.

S_REPLY is used for both PIO and DMA cycles. For PIO reads, S_REPLY indicates that the system controller is ready to read data out of the PIO_RD FIFO. For PIO writes, S_REPLY indicates that data is being written into the PIO_WR FIFO. For DMA reads, S_REPLY indicates that data is being delivered into the DMA_RD FIFO, and for DMA writes, S_REPLY indicates that the system controller is ready to read data out of the DMA_WR FIFO.

The UPA Reply unit is responsible for reading and writing the appropriate data FIFO's and enabling the UPA Data outputs if necessary. In addition, the UPA Reply unit must control the ECC check logic. When data is arriving at U2P (related to a PIO write or DMA read), the data is ECC checked. The UPA Reply unit must accumulate the ECC results for the entire packet, which may be between 1 and 64 bytes in length. The UPA Reply unit manages a separate packet status FIFO which signals the PIO and DMA CTL units of error conditions.

3.3.6 ECC Generate / Check

The ECC unit is split into separate generate and check functions. ECC is always calculated on 64 bits of data. The ECC generate logic is positioned on the "internal" side of all of the data FIFO's. (There is not enough time between receiving S_REPLY and providing data to generate the ECC if the logic is on the UPA side of the FIFO.) This also allows more flexibility in the circuit timing since the UPA clock is faster than the internal U2P clock. In some situations, it is necessary for U2P to generate intentionally bad ECC with the data. When this is needed, bits [1:0] of the outgoing ECC are inverted to provide a guaranteed Uncorrectable Error.

The ECC check logic will detect Correctable and Uncorrectable ECC errors. (CE and UE errors.) Refer to the ECC chapter for the rules for detecting and correcting errors. For a correctable error, the data will be repaired before being sent to the internal destination block. None of the internal U2P units will be aware of CE errors. For both UE and CE errors, the ECC unit will signal the Mondo Dispatch Unit to generate a Mondo Vector (interrupt) if enabled.

3.3.7 DMA Merge Buffer

The DMA Merge Buffer block is used for servicing cacheable DMA Writes of less than 64 bytes (partial writes). This is required in a UPA based system because there is no way to write cacheable memory in sub-line increments. (There are at least 2 problems that force this; the SIMMS do not have individual byte controls and ECC is generated on 8-byte boundaries.). In order to perform a sub-line write, U2P performs a UPA Read-to-Own (P_RDO_REQ) transaction to gain control of the line, merge the new data into the line and then flush the line to memory with a UPA Writeback (P_WRB_REQ) transaction. Once the Merge Buffer's request for a Read-to-Own transaction is granted internally, no other DMA requests will be serviced until the writeback completes.

The only blocks capable of partial writes are the two PBM's and the two streaming caches. The Merge Buffer contains a 64-byte buffer for storing the partial line while waiting for data from the P_RDO_REQ transaction. There are valid bits for each byte in the buffer, so it is able to handle completely arbitrary byte enables on a consistent write from a PCI device. Although the merge buffer could also handle arbitrary byte enables on a streaming access, U2P does not support this because the streaming cache only stores a begin and end pointer for valid data, and not individual byte enables.

To avoid the complexity of having to participate in system coherence during a merge, the external system controller is responsible for blocking all requests to the line for which U2P has issued a Read-to-Own until the data merge is completed and U2P has issued a Writeback of the line to memory. U2P will not issue any other transactions between the Read-to-Own and the Writeback.

The DMA Merge Buffer is not intended to be a high performance solution for sub-line DMA writes from a PCI bus; rather its purpose is to provide correct functionality given the UPA bus constraints. The streaming cache (STC) can be used to improve PCI performance by buffering data into 64-byte lines before flushing to memory. STC line flushes that contain a complete 64 bytes will be able to bypass the Merge Buffer by doing a Write Invalidate (P_WRI_REQ) on the UPA.

3.3.8 PCI Bus Module (PBM)

Each PCI Bus Module block implements a complete PCI Master and Slave interface. Each PBM implements all of the required host bridge functions for PCI, and also acts as the central resource for: arbitration, reset, and system error (SERR#) monitoring.

The PBM handles the timing of PIO requests to the PCI bus. These are handled one at a time. The PBM handles target disconnects, retries and various error conditions during the PIO. If necessary, multiple PCI transactions will be generated for each

PIO (up to 16 transactions in the case of 64-byte block reads or writes). While the multiple transactions of a single PIO are occurring on the PCI bus, DMA requests from other devices on that bus can be still be serviced.

Only 1, 2, 4, 8, 16 or 64-byte aligned PIO read accesses are allowed to the PCI bus Memory Space. Writes to the PCI bus Memory Space may be of any size supported on the UPA. For most PIO's, the command used on the PCI bus will be Memory Read or Memory Write. 64-byte PIO reads will use the Memory Read Line command. Other command types can be generated by PIO's to special regions in the PCI address space. These include the Configuration Read, Configuration Write, I/O Read, I/O Write, and Special Cycle commands. With these command types, only 4-byte or smaller PIO's are supported.

The PBM also responds as a target to other PCI masters. The PBM will respond to any PCI Memory Space transaction for which address bit 31 is on. Typically, the transaction address is treated as a virtual address, and translated to a physical address by the IOMMU. These transactions are referred to as DVMA transactions. The PBM communicates with the IOMMU and STC blocks as needed to complete DVMA cycles to/from the PCI bus. (An IOMMU bypass mode is also available, which can directly access the entire UPA physical address space using PCI Dual-Address Cycles.) DVMA data can be moved from the PCI bus to either the associated STC or directly to the UPA. Peer-to-peer DMA is also allowed between two devices on the same PCI bus segment, but due to the way PCI addressing is defined, U2P is not involved in these transfers (except as the central arbiter for bus request and grant signals).

The PBM will only respond, as a target, to PCI memory space commands (Memory Read, Memory Read Line, Memory Read Line Multiple, Memory Write, and Memory Write & Invalidate). All other PCI command types are ignored.

All PCI transactions targeting U2P will be disconnected by the PBM if the master attempts to cross a 64-byte boundary. Under certain conditions, the PBM will issue a retry for an incoming PCI transaction. These conditions include:

- PBM requests the IOMMU to do a tablewalk to get mapping for this transaction.
- STC indicates that it is initiating a request to get the desired read data.
- Due to congestion, resources (buffers) are currently lacking to accept a transaction.

For DVMA transactions to cacheable memory, based on the IOMMU mapping information for the virtual address, the PBM will treat the DVMA cycle as a **consistent** or **streaming** access (accesses made in IOMMU bypass mode are always treated as consistent). Consistent accesses are sent directly to the UPA and have strict ordering constraints; The performance of consistent accesses can be worse than streaming accesses (particularly for reads or sub-line writes), and DVMA pages should only be marked consistent-mode when necessary. DVMA accesses to non-cacheable memory is always treated in consistent mode.

For consistent DVMA reads, the PBM treats all three PCI memory read commands identically. For streaming reads, the PBM passes the information on which command was used to the streaming cache so that a decision can be made on prefetching data. For all DVMA write transactions, both PCI memory write commands are treated the same.

For DVMA reads, the DVMA master may drive arbitrary byte enables on the PCI bus, which will be ignored. DVMA reads always generate 64-byte requests on the UPA bus, and correct data is returned for all byte lanes on the PCI bus, regardless of the byte enables.

For consistent DVMA writes, arbitrary byte enables are also allowed. The byte enables for the transaction are stored along with the data, and are passed on to the Merge Buffer for partial line writes to cacheable space. For non-cacheable partial writes, the byte enables are passed on to the Bus Controller/DMA Controller, which uses them for the Bytemask field of the outgoing P_NCWR_REQ packet(s).

For streaming DVMA writes, arbitrary byte enables are not allowed. Within a single PCI transaction, all data must be contiguous bytes. If any byte holes are detected, the PBM will set a status bit, and an interrupt will be generated if enabled. Meanwhile, the transaction continues as if the byte hole were not there, and the appropriate byte enables were on. This will cause incorrect data to be eventually be written to memory for these bytes. This only applies to a single continuous PCI transaction - gaps between the end address of one transaction and the start address of the next are allowed, and correctly handled by the streaming cache (although they may cause performance degradation).

The PBM also helps to enforce certain ordering constraints between consistent DVMA writes (cacheable or non-cacheable) and the following synchronization events:

- PIO reads of PCI registers.
- Interrupts.
- Other consistent DVMA writes (e.g. a descriptor update).

For PIO reads (to PCI space, not internal registers), the PBM for the targeted bus communicates with the DMA Controller to ensure that all of its previous consistent DVMA writes have completed before allowing the PIO to complete.

For PCI related interrupts, the MDU notifies the appropriate PBM when an interrupt is received. The PBM then notifies the MDU when all of its outstanding consistent DVMA writes have been flushed. The MDU will not generate the interrupt packet until the PBM has flushed data.

Descriptor updates are correctly handled by the strict ordering of all consistent DVMA accesses.

The only PCI bus function that is not handled by the PBM is the interrupt logic. This is contained in the MDU block.

3.3.9 IOMMU

This block is used for PCI DVMA cycles. It maps 32-bit PCI Virtual Addresses to 41-bit UPA Physical Addresses for both PBM blocks. There is a single 16-entry Translation Look-aside Buffer (TLB) to cache recently used translations. The TLB entries are replaced on an LRU basis, without regard to the bus of origin. The IOMMU can provide 2 levels of service when a PBM presents a virtual address for translation:

- First, the IOMMU examines the TLB to see if a translation for the virtual address is already available.
- If there is a miss in the TLB, the IOMMU block will perform a HW table-walk to get the translation if requested by the PBM (since the PBM also checks the streaming cache for a translation, this may not be necessary). The IOMMU does this by reading from the TSB table by issuing a DMA read to main memory. This is only a single-level table search, unlike previous Sun MMU models.

The IOMMU allows only a single translation to be in progress at a time. This includes the tablewalk portion of a translation, so if one PBM has requested a tablewalk, translation requests from the other PBM are held off until the tablewalk completes.

In the case of simultaneous translation requests by both PBM's, priority is given to PBM A.

3.3.10 Streaming Cache

Each Streaming Cache (STC, but sometimes referred to as a Streaming Buffer) is used to accelerate DVMA traffic to/from its associated PCI bus. It contains a pool of 16 64-byte entries. These entries are tagged by virtual page number, and are managed as a fully-associative cache. Only one entry will be valid for any given virtual page. Entries are assigned as needed by the STC logic. An LRU algorithm is used to assign new pages to entries when all of the entries are valid. All 16 entries are available for either read or write streams, although at a given time, each entry is only valid for a single direction.

For DVMA writes, the STC will buffer up data in an entry until a 64 byte has been reached. The STC will then flush the completed line into a flush buffer. As soon as the internal busses are available, data in the flush buffer is sent to the UPA block. The flush is guaranteed to occur if the last word of the line has been written - there is no possibility of a completed dirty line being left in the streaming cache for an indeterminate amount of time. For DVMA reads, the STC will often be able to prefetch a new 64 byte line into a prefetch buffer, and then copy it into the correct streaming cache entry before it is needed by the requesting device. This prefetch is initiated whenever the Memory Read Line or Memory Read Line Multiple commands are used on the PCI bus, as signalled to the STC by the PBM, and there is

not already an outstanding prefetch request waiting for data. A prefetch is also initiated if it has not already been issued and the last word of a line is read. Prefetches are never issued when a page boundary is reached.

The STC expects that the DVMA device is accessing data in sequential and increasing order, without any byte holes. If the actual device access pattern is different, the STC, in concert with the PBM, will maintain data correctness but the performance gains will not be as high. One exception to data correctness is if a device generates byte-holes within a single write transaction. When this happens, the byte enables in the byte hole are treated as if they were on (thus possibly causing data corruption), and a Streaming Byte Hole Interrupt is signalled (if enabled).

Data which is stored in the STC does **not** participate in the UPA cache coherence protocol. The STC implements a flush command to allow system software to explicitly remove virtual pages from the STC when a DVMA transfer is done or when an IOMMU demap operation occurs. In order to ensure that the STC flush data has reached UPA memory, a special synchronization register is provided.

The two streaming caches in U2P do not communicate with each other. There is no snooping done to determine if the same virtual page is in use in both caches. It is up to software to ensure that either no devices from separate busses access the same virtual page in streaming mode, or, if they do, that they do not access the same 64-byte lines within the page. (Note that the same warning applies to having multiple virtual addresses in either or both streaming caches map to the same physical address.)

3.3.11 MDU

The Mondo Dispatch Unit is U2P's vehicle for dispatching Interrupt packets to an Interrupt Handler on the UPA bus (primarily a CPU). The MDU will generate a special type of UPA packet (a Mondo Vector, P_INT_REQ). The MDU block accepts external interrupt requests from PCI or UPA devices (encoded onto a 6-bit INT_NUM bus) as well as internal U2P interrupt sources and dispatches Interrupt packets to the UPA. The contents and target of the interrupt packet are controlled through the Interrupt Number Registers (INR) within the MDU. Each INR is 16 bits, with 5 of these bits indicating the MID of the target CPU. For simplicity, no data other than the interrupt number (INO) is sent in the 64-byte interrupt packet from U2P (unused bits are all sent as 0s).

There are 38 external interrupt sources that can have their requests serviced through the MDU. In order to conserve pins on U2P, these are handled by an external interrupt concentrator (e.g. the RIC chip). The interrupt concentrator sends interrupt requests to the U2P by encoding them onto a 6 bit interface.

Once an interrupt is received from the external concentrator, it is put into one of 2 groups, based on the least significant bit of the target MID programmed into the corresponding INR (U2P is optimized for a system with 2 CPU's, but can be used in systems with up to 4 CPU's). Within each of these groups, the MDU performs a priority arbitration to determine which interrupt to send.

Before any PCI related interrupt packet is sent to the UPA, the MDU checks with the appropriate PBM block to see if it has any posted consistent DMA write data. If so, the MDU waits until the PBM indicates that the write data has been sent to the UPA block.

The Mondo Interrupt packet is then sent to the target CPU using the same UPA queue that is used for DMA writes. The Mondo packet can be either ACKed or NACKed by the UPA. If the packet is NACKed (rejected), the CPU is already busy servicing another Mondo. In this case, the MDU will resubmit the packet at a later time based on a free-running retry interval counter. (This retry interval is programmable.) In the meantime, Mondo packets can still be sent to other CPU's (as long as they differ in the LSB of the MID). To simplify the design, U2P can only have one Mondo vector outstanding (i.e. waiting for ACK or NACK) at any time.

3.3.12 Timer / Counters

There are two identical, independent 29-bit timer/counters in U2P. Each can provide either periodic interrupts or single-event interrupts to a selected processor. The interrupt is delivered to the target CPU using a Mondo vector, and each counter can target a different CPU. The counters are driven by the TMR_CLK input, which is nominally at 10MHz. This clock is scaled down by a factor of 10 first, so the counters will typically increment once a microsecond, which allows periodic interrupt intervals of up to 536 seconds.

Each counter has an associated Limit Register, and a Periodic enable bit. When a counter reaches its limit value, an interrupt is generated (if enabled). If the Periodic bit is set, the count is reset to 0, otherwise it is left alone (the count is also reset to 0 whenever the Limit Register is written). To obtain a periodic interrupt every 'N' microseconds, the limit value should be set to 'N-1'.

3.3.13 Reset

A synchronous reset is implemented in U2P. UPA_RST_L is the source of this reset and it is distributed to 3 internal clock domains and to the PCI bus.

To the UPA domain UPA_RST_L is registered on input and distributed to the various modules within the domain. Each of those modules further registers the reset before distribution to the destination flops. This gives a 3 cycle delay between the external reset pin and the time the internal logic is reset.

In the PSYCLK domain UPA_RST_L will occur at the destination flops either 1 or 2 clocks from the time of it's assertion. This is due to the fact that UPA_RST_L is based in the UPACLK time domain and is thus asynchronous to the PSYCLK domain. The de-assertion of UPA_RST_L will occur at the destination flops a maximum of 3 PSYCLK cycles later. This is accomplished by sending UPA_RST_L through a dual rank synchronizer which feeds an AND function, and at the same time by-passing the synchronizer with UPA_RST_L to feed the other term of the AND function.

To the PCI bus, UPA_RST_L is asserted asynchronously and de-asserted synchronously. This is accomplished using the dual rank synchronizer and AND function described in the previous paragraph. The PCI signal PCI_RST_ will be asserted in the same cycle as UPA_RST_L and will be de-asserted 2 PSYCLK cycles after UPA_RST_L.

3.3.14 Testability

U2P has a JTAG (IEEE 1149.1) compliant TAP controller and boundary scan. In addition, all internal functional flip-flops are scannable. Several other scan based test and debug features are implemented as well, including Built-In Self-Test (BIST) circuitry for internal memories that are not directly accessible via PIO accesses. The Design-for-Testability (DFT) features of U2P are further documented in Chapter 12.

DMA/PIO Transactions Flow

This chapter describes the flow of DMA and PIO transactions through U2P's UPA (Unified/UltraSPARC Port Architecture) bus interface. The major generic blocks involved in any DMA transaction are the Bus Controller, DMA controller, and UPA bus interface (and the Merge Buffer for coherent DMA writes of less than 64 Bytes). The major blocks involved in any PIO transaction are the Bus Controller, PIO Decoder, and the UPA bus interface.

Figure 4-1 shows a top level block diagram of the interconnection between the blocks responsible for DMA and PIO transactions control.

Note – This chapter assumes that the reader is familiar with the basics of the UPA (Unified/UltraSPARC Port Architecture) Interconnect. Please refer to “UPA Interconnect Architecture” Release 2.0, Document Part Number 960-1156-01.

4.1 Block Diagram

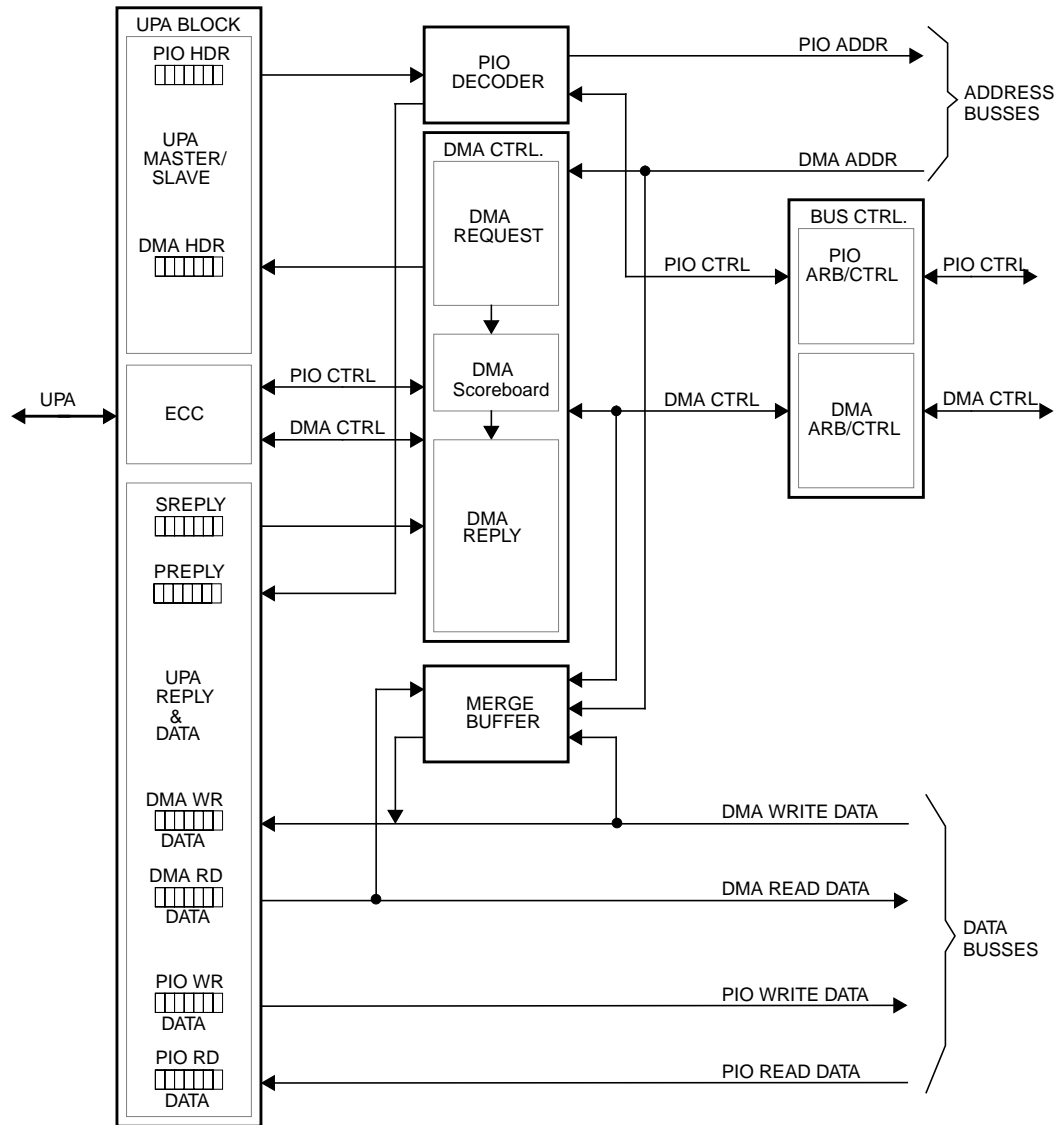

Figure 4-1 Top level block diagram for DMA and PIO transactions flow/control

- **UPA Block:** This block is U2P's interface to the UPA bus. It is composed of three major sub-blocks:
 - a. UPA Master/Slave: This block is so called because it simultaneously operates in two different modes, Master and Slave. In Master mode, it arbitrates for the UPA bus and puts a UPA request on the UPA address bus after it wins arbitration. In slave mode, it listens to the UPA address bus waiting for a transaction.
 - b. UPA Reply/Data: This block contains all data FIFO's needed to buffer DMA and PIO data. It also handles P_REPLY and S_REPLY packets.
 - c. ECC: This block generates ECC on data sent from U2P to the UPA bus, and checks ECC on data received from the UPA bus.
- **DMA Controller:** This block is responsible for building DMA transaction packets sent to the UPA bus and for keeping track of them. It is composed of three major sub-blocks:
 - a. DMA Request: DMA requests from U2P's internal blocks are sent to this block under control from the Bus Controller. The DMA Request block then builds the appropriate UPA transaction and inserts it in the DMA header FIFO in UPA Master/Slave. At the same time it sends all information related to the DMA transaction to the Scoreboard to be stored until the DMA transaction is completely serviced (i.e., DMA read data has been received, or DMA write data has been taken).
 - b. DMA Reply: The UPA Reply/Data block forwards all DMA related S_REPLY's to this block to be decoded. If the S_REPLY is related to an outstanding DMA read, the DMA reply arbitrates for U2P's internal busses to deliver the DMA read data and removes the DMA request from the scoreboard. If the S_REPLY is related to an outstanding DMA write, the DMA Reply just removes the DMA write request from the scoreboard. This block also drives the appropriate Ack and Nack signals to U2P's internal blocks based on the S_REPLY type.
 - c. Scoreboard: The scoreboard keeps a record of all outstanding DMA transactions to the UPA. It stores the following DMA related information:
 - i. Transaction direction (Read/Write).
 - ii. Cacheable bit to indicates transaction destination (memory vs. IO).
 - iii. 16-bit Byte Mask.
 - iv. ID of the block that initiated the DMA transaction.
 - v. Special field (4 bits) that can be used by the block which initiated the DMA to store any type of information. The Streaming Cache, for example, stores an index number to its 16 buffers. This index number is returned to the streaming cache along with the DMA read data.
 - vi. DMA address (used for DMA read error recording).

- **PIO Decoder:** The UPA Master/Slave passes UPA transactions to this block to be decoded. The PIO Decoder extracts from the UPA transaction the PIO address, destination, direction (read or write), byte mask, and transfer size. Outputs of this block are used by the Bus Controller to initiate the PIO access internally.
- **Bus Controller:** This block is in charge of concurrently coordinating DMA and PIO transactions inside U2P. It is composed of three major sub-blocks. The first one controls PIO transactions to all internal blocks. The second one is responsible for arbitration between internal blocks and for passing DMA requests to the DMA Controller. The third block communicates with the DMA Reply to deliver DMA read data to the requesting block.
- **Merge Buffer:** The merge buffer concept was introduced to eliminate the need for U2P to participate in the UPA cache coherence protocol. Its main function is to handle coherent DMA writes to main memory which are less than 64 Bytes. When the Bus Controller detects that the size of the write transaction is less than 64 Bytes it informs the merge buffer. The merge buffer fetches the addressed data block (64 Bytes) from the memory and merges the new data, then it writes the data block back into the memory.

U2P's internal blocks that issue DMA transactions destined for the UPA are called in this chapter **Requesting Sources or Blocks**. These sources include the PBM Modules (A & B), the Streaming Caches (A & B), the Merge Buffer, the Mondo Dispatch Unit (Interrupts are treated as DMA Writes), and the IOMMU. Blocks that can be accessed in slave mode (PIO) are called **Destination Blocks**. These blocks include, in addition to all requesting blocks, the UPA interface, the ECC block, the Timer block, the Scoreboard, and the Performance registers.

The acronyms below are used in the following sections:

- **DMA_HDR:** A 70 bit DMA header which is basically the two cycles of a UPA transaction (side by side) without the parity bits.
- **DMA_HDR FIFO:** DMA Header FIFO used to buffer UPA transactions until U2P wins the UPA bus arbitration.
- **DMA_WR FIFO:** DMA Write Data FIFO.
- **DMA_RD FIFO:** DMA Read Data FIFO.
- **P2U_DD:** PCI-to-UPA DMA Data (DMA Write Data).
- **U2P_DD:** UPA-to-PCI DMA Data (DMA Read Data).
- **P2U_DA:** PCI-to-UPA DMA Address.
- **PIO_HDR:** A 71 bit PIO header which is basically the two cycles of a UPA transaction received from the UPA bus (side by side) without the parity bits. Bit 71 is set if a parity error is detected in either of the two cycles.
- **PIO_HDR FIFO:** PIO Header FIFO used to buffer UPA transactions forwarded to U2P from the SC.
- **PIO_WR FIFO:** PIO Write Data FIFO.
- **PIO_RD FIFO:** PIO Read Data FIFO.

- **U2P_PD**: UPA-to-PCI PIO Data (PIO Write Data).
- **P2U_PD**: PCI-to-UPA PIO Data (PIO Read Data).
- **U2P_PA**: UPA-to-PCI PIO Address.

4.2 DMA Transaction Flow

This section describes the flow of a DMA request and reply through the DMA Controller. Refer to the figures provided below for each step described in the transaction flow (a step number is shown on the corresponding figure in a circle). The delta between the numbers in circles does not necessarily represent the actual number of clock cycles between steps.

The following discussion uses a simplified signal handshake protocol between the requesting DMA source and the Bus Controller. See Chapter 3 for more details.

Note – U2P uses class 0 only for all UPA transactions. Class 1 is not used.

4.2.1 DMA Write Transactions

4.2.1.1 64 and 16 Byte DMA Writes to IO Space

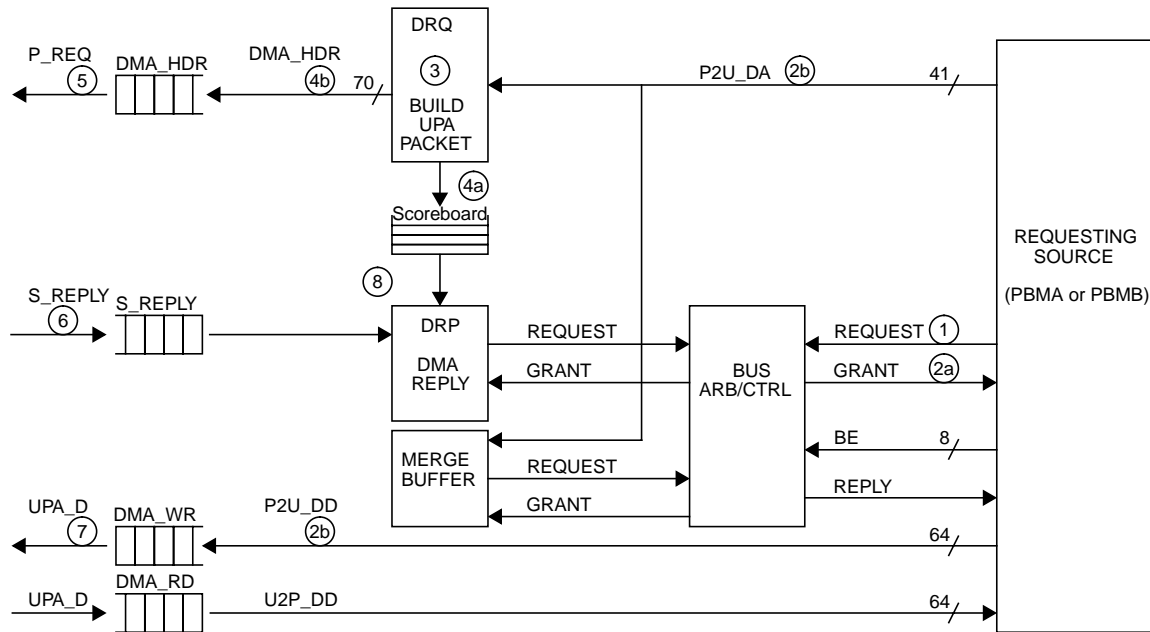

Figure 4-2 DMA Write to IO space

Note – PBMA and PBMB are the only blocks which access IO space

PBMA is used as an example of a requesting block.

1. PBMA raises a request for a transfer. It indicates a write with the C bit clear (non-Cacheable). It also indicates the size which can be either 64 bytes or any arbitrary number of bytes less than or equal to 16. The Bus Controller begins arbitration.
2. Two things happen:
 - a. PBMA wins arbitration.
 - b. PBMA drives address and data busses. Data is entered into DMA_WR FIFO.

3. The DMA header (DMA_HDR) is formed in the DMA request block (DRQ). If the size is less than or equal to 16 bytes, the value on the Byte Enable (BE) lines from PBMA is used to determine the Bytemask field in the UPA transaction.
4. Two things happen:
 - a. The Request is entered in the DMA Scoreboard.
 - b. The Request is entered in the DMA header (DMA_HDR) FIFO in the UPA interface.
5. P_REQ packet is issued on the UPA bus. Table 4-1 shows the type of P_REQ packets issued and the type of possible S_REPLY.

Table 4-1 Type of P_REQ and S_REPLY used for DMA write to IO space

Source	Size (byte)	P_REQ	S_REPLY
PBMA, PBMB	1 - 16	P_NCWR_REQ	S_WAS
	64	P_NCBWR_REQ	S_WAB

6. S_REPLY received from SC (System Controller). Table 4-2 briefly describes the action taken by U2P based on the type of S_REPLY it receives.

Table 4-2 Type of S_REPLY's U2P receives

S_REPLY	Description
S_WAS	Write Ack Single. U2P sources 16B of data from DMA_WR FIFO.
S_WAB	Write Ack Block. U2P sources 64B of data from DMA_WR FIFO.
S_INAK	Interrupt NACK. No data is transferred. U2P retries sometime later.
S_RBU	Read Block Ack. Unshared. U2P receives 64B of data into DMA_RD FIFO.
S_RBS	Read Block Ack. Shared. U2P receives 64B of data into DMA_RD FIFO.
S_SWB	Write Block Ack. U2P receives 64B data into PIO_WR FIFO.
S_SWS	Write Single Ack. U2P receives 16B data into PIO_WR FIFO.
S_SRB	Read Block Ack. U2P sources 64B data from PIO_RD FIFO.
S_SRS	Read Single Ack. U2P sources 16B data from PIO_RD FIFO.
S_ERR	Error. No data is transferred.
S_RTO	Read Time Out. No data is transferred.

7. U2P sources write data from DMA_WR data FIFO to UPA data bus.
8. The DMA Reply Controller is informed of the reply. It removes the transaction from the scoreboard. U2P considers the DMA write transaction complete.

4.2.1.2 64 Byte DMA Write to Memory

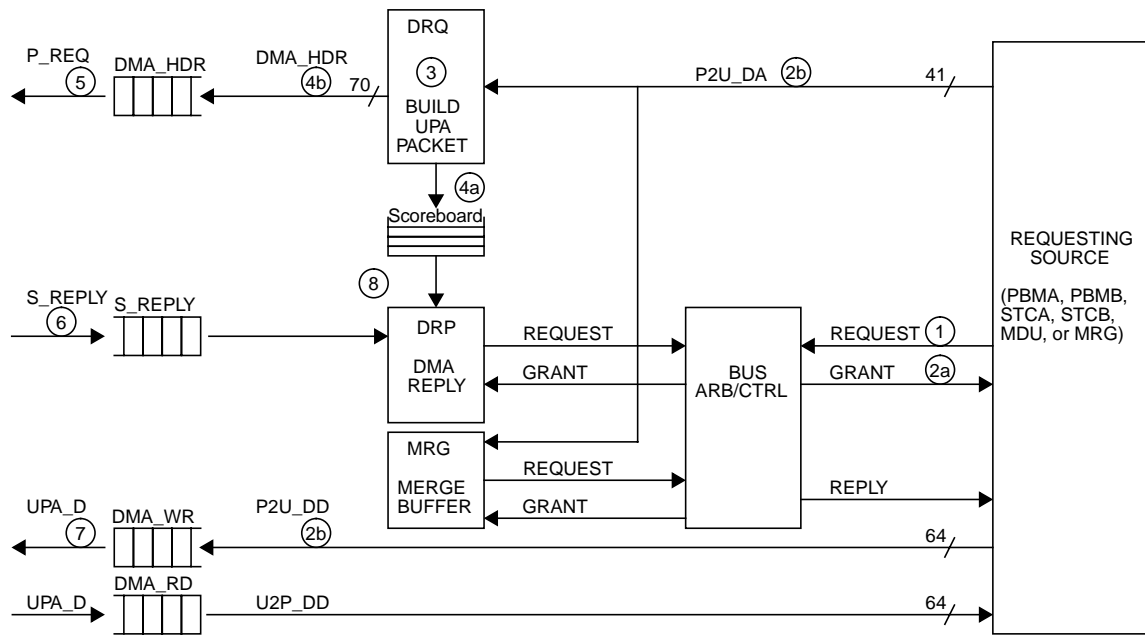

Figure 4-3 64 Bytes DMA Writes to Memory

Note – PBMA, PBMB, STCA, STCB, and Merge Buffer (MRG) do 64 bytes DMA writes to memory. Interrupt transactions from MDU have identical flow.

PBMA is used as an example of a requesting block.

1. PBMA raises a request for a transfer. It indicates a 64B write with the C bit set (Cacheable). The Bus Controller begins arbitration.
2. Two things happen:
 - a. PBMA wins arbitration.
 - b. PBM drives address and data busses. Data is entered into DMA_WR FIFO.

3. The UPA header is formed in the DRQ. 64 Byte writes bypass the merge buffer.
4. Two things happen:
 - a. The Request is entered in the DMA Scoreboard.
 - b. The Request is entered in the DMA_HDR FIFO in the UPA interface.
5. P_REQ packet is issued on the UPA bus. Table 4-3 shows the type of P_REQ packets issued and the type of possible S_REPLY.

Table 4-3 Type of P_REQ and S_REPLY used for 64 byte DMA writes to memory

Source	Size (byte)	P_REQ	S_REPLY
PBMA, PBMB	64	P_WRI_REQ	S_WAB
STCA, STCB	64	P_WRI_REQ	S_WAB
MRG	64	P_WRB_REQ	S_WAB
MDU	64	P_INT_REQ ¹	S_WAB S_INAK

1. The flow of interrupt transaction is similar to 64 byte DMA write transactions, therefore it is shown here.

6. S_REPLY received from SC (System Controller). See Table 4-2 for brief description of the action taken by U2P based on the type of S_REPLY it receives. It is assumed here that U2P receives S_WAB.
7. U2P sources write data from DMA_WR data FIFO to UPA data bus.
8. The DMA Reply Controller is informed of the reply. It removes the transaction from the scoreboard. U2P considers the DMA write transaction complete.

4.2.1.3 Less than 64 Byte DMA Write to Memory

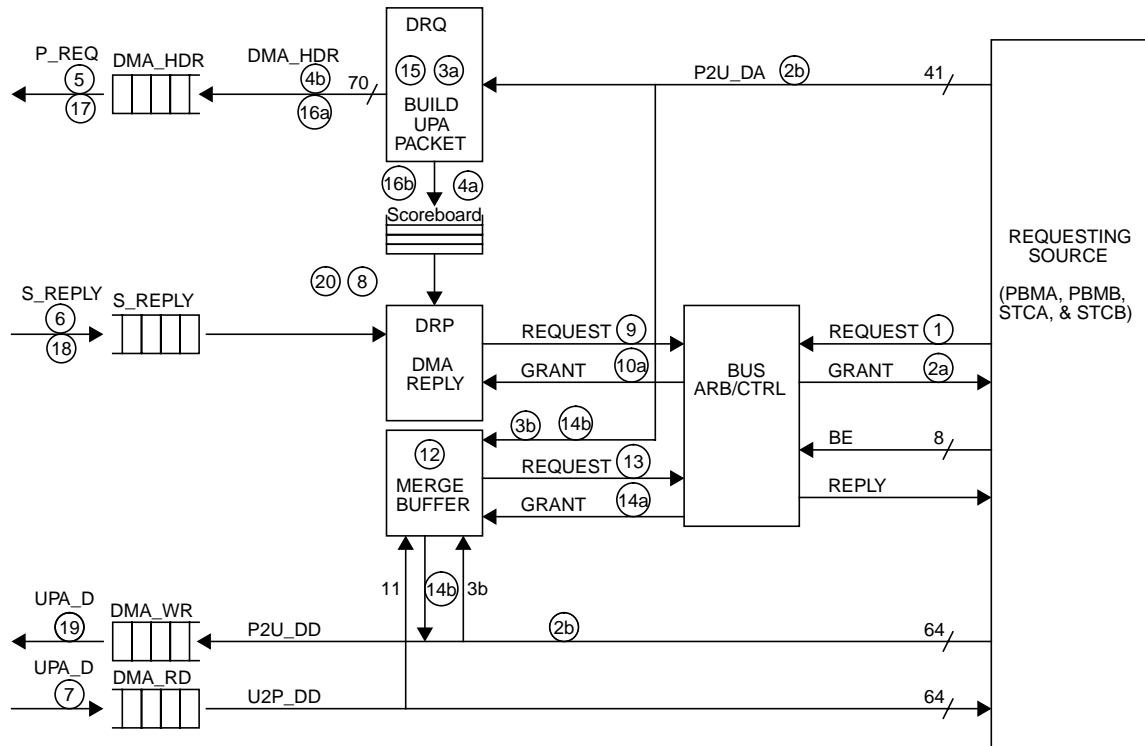

Figure 4-4 Less than 64 Bytes DMA Writes to Memory

Note – Only PBMA, PBMB, STCA, & STCB issue less than 64 Bytes DMA write.

PBMA is used as an example of a requesting block.

1. PBMA raises a request for a transfer. It indicates a write with the C bit set (Cacheable). It also indicates that the size is less than 64 bytes. The size can be any arbitrary number of bytes less than or equal 63 bytes. The Bus Controller begins arbitration.
2. Two things happen:
 - a. PBMA wins arbitration. DMA Requests from all other blocks are blocked.
 - b. PBMA drives address and data busses (and byte enable lines).

3. Two things happen:
 - a. The DMA header is formed in the DMA request block (DRQ). The DRQ recognizes that it is less than 64 Byte write to memory, so it forms a Read-To-Own transaction to read the whole block (64B) that contains the addressed data and forwards it to the merge buffer upon return.

Note – Read-To-Own (P_RDO_REQ) transaction is issued with DVP bit set.

- b. Write address and data are sent to the merge buffer along with the value on the Byte Enable (BE) lines.
4. Two things happen:
 - a. The Request is entered in the DMA Scoreboard. The requestor ID is changed from PBMA to Merge buffer (MRG) before the transaction is entered in the scoreboard.
 - b. The Request is entered in the DMA_HDR FIFO in the UPA interface.
5. P_REQ packet is issued on the UPA bus. Table 4-4 shows the type of P_REQ packets issued and the type of possible S_REPLY.

Table 4-4 Type of P_REQ and S_REPLY used for less than 64 byte DMA writes

Source	Size (byte)	P_REQ	S_REPLY
PBMA, PBMB	1-63	P_RDO_REQ	S_RBU S_ERR S_RTO
STCA, STCB	1-63	P_RDO_REQ	S_RBU S_ERR S_RTO
MRG	64	P_WRB_REQ	S_WAB

6. S_REPLY received from SC (System Controller). See Table 4-2 for brief description of the action taken by U2P based on the type of S_REPLY it receives. It is assumed here that U2P receives S_RBU for P_RDO_REQ and S_WAB for P_WRB_REQ.
7. U2P latches read data into DMA_RD data FIFO.
8. The DMA Reply Controller is informed of the reply. It removes the transaction from the scoreboard.
9. The DMA Reply raises a request to return the data to the merge buffer (DMA Reply gets the requestor ID from the scoreboard). The bus controller begins arbitration.
10. Two things happen:
 - a. The DMA Reply wins arbitration.

- b. Bus controller informs the Merge Buffer to receive the read data by asserting signal Reply (not shown).
11. Data is sourced from DMA_RD data FIFO to merge buffer.
 12. Data is merged inside the merge buffer (the byte enable value received earlier is used during the merge).
 13. Merge buffer raises a request to write back the merged data. It wins arbitration next clock because DMA requests from other blocks are stalled.
 14. Two things happen:
 - a. Merge Buffer wins arbitration.
 - b. Merge Buffer drives address and data busses. Data is entered into DMA_WR FIFO.
 15. The DMA header is formed in the DMA request block (DRQ).
 16. Two things happen:
 - a. The Request is entered in the DMA Scoreboard.
 - b. The Request is entered in the DMA_HDR FIFO in the UPA interface.
 17. P_REQ packet is issued on the UPA bus (See Table 4-4).
 18. S_REPLY received from SC (System Controller).
 19. U2P sources write data from DMA_WR data FIFO to UPA data bus.
 20. The DMA Reply Controller is informed of the reply. It removes the transaction from the scoreboard. DMA Activity is allowed to proceed. U2P considers this less than 64 byte DMA write transaction complete.

Note – Possible overlapping between the steps above is not shown.

4.2.2 DMA Read Transactions

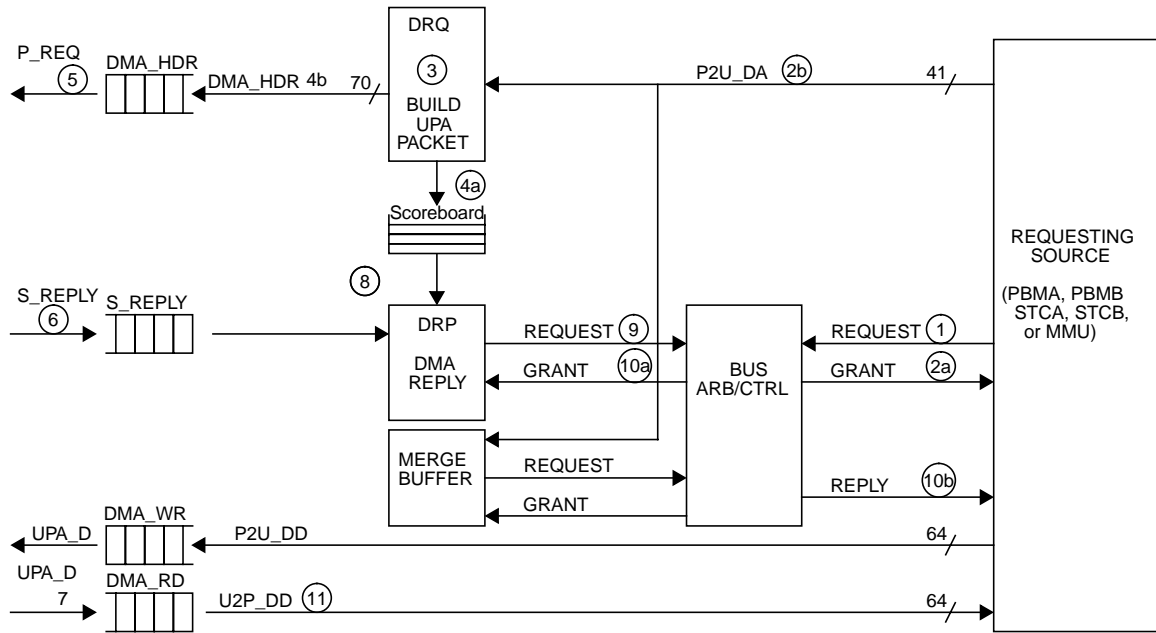

Figure 4-5 DMA read request to memory or IO space

Note – PBMA, PBMB, STCA, STCB, and MMU submit DMA read requests. Only PBMA and PBMB blocks access IO space.

PBMA is used in the example below.

1. PBMA raises a request for a transfer. It indicates a read and the request size. The Bus Controller begins arbitration.
2. Two things happen:
 - a. PBMA wins arbitration.
 - b. PBMA drives the address bus.
3. The DMA header is formed in the DMA request block (DRQ). Reads from coherent domain are sent out as a 64 byte transactions regardless of size, with the extra data ignored upon return.
4. Two things happen:

- a. The Request is entered in the DMA Scoreboard.
 - b. The Request is entered in the DMA_HDR FIFO in the UPA interface.
5. P_REQ packet is issued on the UPA bus. Table 4-5 shows the type of P_REQ packets issued and the type of possible S_REPLY.

Table 4-5 Type of P_REQ and S_REPLY used for DMA reads

Source	C ¹	Size (byte)	P_REQ	S_REPLY
PBMA, PBMB	1	Any size	P_RDD_REQ	S_RBS S_ERR S_RTO
	0	Any size	P_NCBRD_REQ	S_RBU S_ERR S_RTO
STCA, STCB	1	64	P_RDD_REQ	S_RBS S_ERR S_RTO
MMU	1	64	P_RDD_REQ	S_RBS S_ERR S_RTO

1. Cacheable bit (1=Cacheable, 0=Non-Cacheable)

- 6. S_REPLY received from SC (System Controller). See Table 4-2 for brief description of the action taken by U2P based on the type of S_REPLY it receives. It is assumed here that S_REPLY is not of type S_ERR or S_RTO.
- 7. U2P latches read data into DMA_RD data FIFO.
- 8. The DMA Reply Controller is informed of the reply. It removes the transaction from the scoreboard.
- 9. The DMA Reply raises a request to return the data to the requesting block.
- 10. Two things happen:
 - a. The DMA Controller wins arbitration.
 - b. Bus controller inform the requesting block to receive the read data by asserting signal Reply.
- 11. Data is sourced from DMA_RD data FIFO. U2P considers the DMA read transaction complete.

4.3 PIO Transaction Flow

This section describes the flow of PIO transactions through U2P. Size of PIO reads can be 1, 2, 4, 8, 16, or 64 bytes. Size of PIO writes can be 64 bytes or any arbitrary number of bytes from 1 to 16 bytes. PIO accesses destined to U2P's internal blocks are restricted to be 8 bytes or less.

Note – Only 1 PIO transaction is processed at a time in U2P.

4.3.1 PIO Write

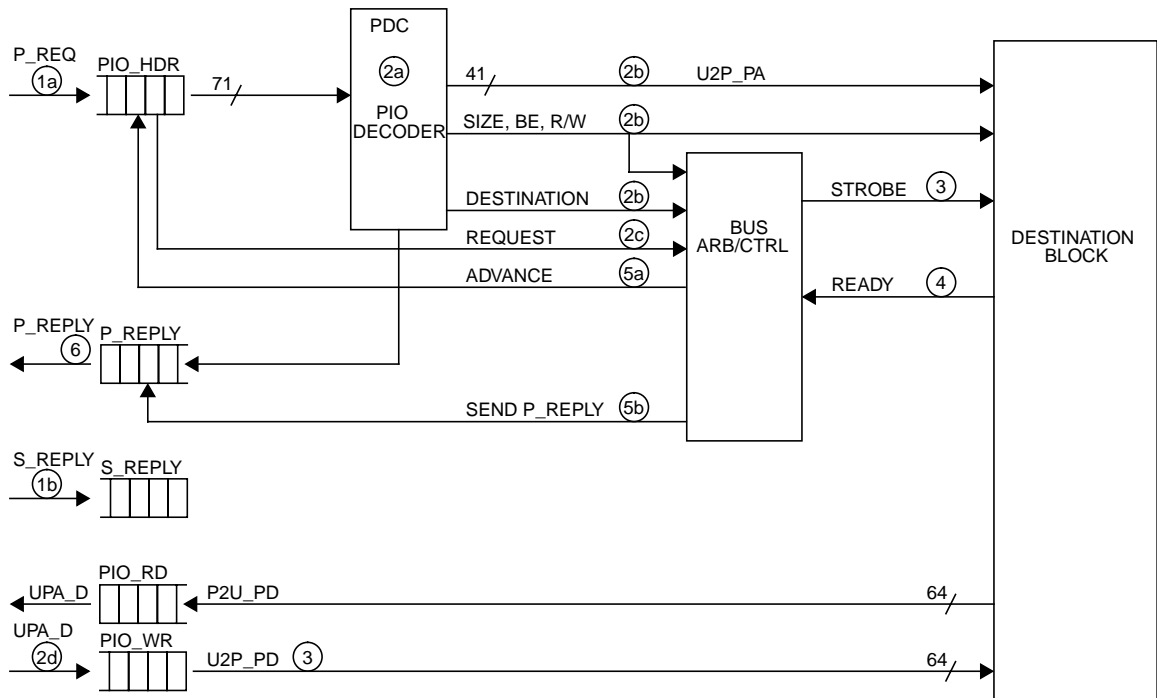

Figure 4-6 PIO Write Transaction Flow

1. Two things happen:

- a. A PIO Write request enters the PIO_HDR FIFO.
- b. The corresponding S_REPLY enters S_REPLY FIFO. The S_REPLY tells U2P that write data is valid next cycle.

Note – Since the address and data paths on the UPA bus are independent, P_REQ and corresponding S_REPLY can arrive in any order. It is assumed here for simplicity that they both arrive at the same time.

Table 4-6 lists all valid write P_REQ's and S_REPLY's that U2P receives as well as the P_REPLY's it generates in response. Table 4-7 provides brief description of the P_REPLY's generated by U2P. See Table 4-2 for description of S_REPLY.

Table 4-6 Type of write P_REQ's U2P receives and type of P_REPLY it generates

Destination	Size (byte)	P_REQ	P_REPLY ¹	S_REPLY
PBMA, PBMB	1 - 16	P_NCWR_REQ	P_WAS P_FERR	S_SWS
	64	P_NCBWR_REQ	P_WAB P_FERR	S_SWB
Other Blocks	1 - 8	P_NCWR_REQ	P_WAS P_FERR	S_SWS

1. Default P_REPLY is P_IDLE.

Table 4-7 Type of P_REPLY's generated by U2P

P_REPLY	Description
P_IDLE	Idle. This is the default P_REPLY.
P_RAS	Read Ack Single. Tells SC 16B of read data is ready in PIO_RD data FIFO.
P_RAB	Read Ack Block. Tells SC 64B of read data is ready in PIO_RD data FIFO.
P_WAS	Write Ack Single. Tells SC 16B of write data has been absorbed.
P_WAB	Write Ack Block. Tells SC 64B of write data has been absorbed.
P_RERR	Read Error. No data is transferred.
P_FERR	Fatal Error. No data is transferred.
P_RTO	Read Time Out. No data is transferred.

2. Four things happen:
 - a. PIO header is decoded by the PIO decoder (PDC). Size, destination, and direction of PIO transaction are determined.
 - b. PIO transaction information is made available to the bus controller. U2P_PA, size, and direction of transaction are visible to all internal blocks. Byte Enable (BE) lines are used by PBMA and PBMB only.
 - c. A request signal is sent from the PIO_HDR FIFO in the UPA interface to the bus controller.
 - d. UPA data is entered into PIO_WR FIFO. Bus Controller is informed.
3. The Bus Controller sees the request along with the PIO transaction size (and byte enable lines), destination, and direction. It asserts Strobe signal which indicates that address, size, byte enable, direction, and data on U2P_PD are valid.

4. The destination block asserts signal **READY** indicating that it took the data.

Note – For multi-cycle PIO's (size > 8 bytes), signal **READY** is asserted for every data cycle (see Bus Controller chapter for details).

5. Two things happen:

- a. The Bus Controller notifies the UPA interface to advance **PIO_HDR** FIFO and begins processing the next request.
- b. The Bus Controller inserts the **P_REPLY** packet from PIO decoder into **P_REPLY** FIFO in the UPA interface.

6. UPA interface sends the **P_REPLY** packet. PIO transaction is complete as far as U2P is concerned.

4.3.2 PIO Read

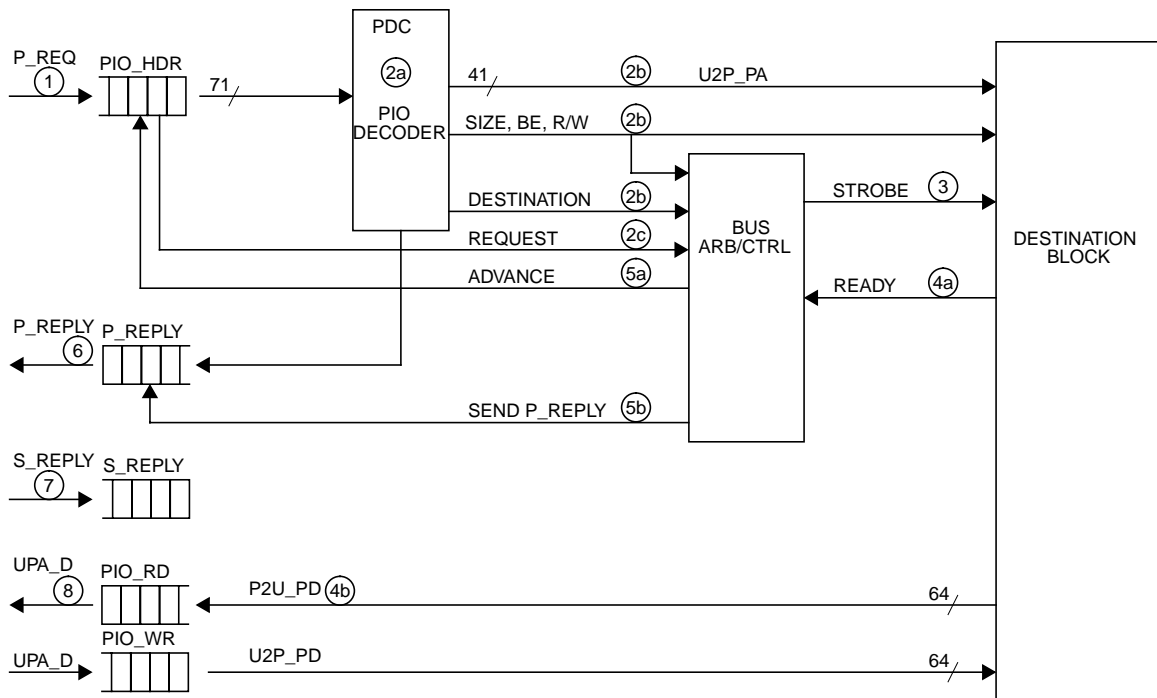

Figure 4-7 PIO Read Transaction Flow

1. A PIO Read request enters the PIO_HDR FIFO.

Table 4-8 lists all valid read P_REQ's and S_REPLY's that U2P receives as well as the P_REPLY's it generates in response. Table 4-7 provides brief description of the P_REPLY's generated by U2P. See Table 4-2 for description of S_REPLY.

Table 4-8 Type of read P_REQ's U2P receives and type of P_REPLY it generates

Destination	Size (byte)	P_REQ	P_REPLY ¹	S_REPLY
PBMA, PBMB	1, 2, 4, 8, 16	P_NCRD_REQ	P_RAS P_PERR P_RTO P_FERR	S_SRS
	64	P_NCBRD_REQ	P_RAB P_PERR P_RTO P_FERR	S_SRB
Other Blocks	1, 2, 4, 8	P_NCRD_REQ	P_RAS P_PERR P_RTO P_FERR	S_SRS

1. Default P_REPLY is P_IDLE.

2. Three things happen:

- a. PIO header is decoded by the PIO decoder (PDC). Size, destination, and direction of PIO transaction is determined.
- b. PIO transaction information is made available to the bus controller. U2P_PA, size, and direction of transaction are visible to all internal blocks. Byte Enable (BE) lines are used by PBMA and PBMB only.
- c. A request signal is sent from the PIO_HDR FIFO in the UPA interface to the bus controller.

3. The Bus Controller sees the request along with the PIO transaction size (and byte enable lines), destination, and direction. It asserts Strobe signal which indicates that address, size, byte enable, and direction are valid.

4. Two things happen:

- a. The destination block asserts signal READY indicating that it is driving the data.

Note – For multi-cycle PIO's (size > 8 bytes), signal READY is asserted for every data cycle (see Bus Controller chapter for details).

- b. Data is valid on P2U_PD bus.

5. Two things happen:

- a. The Bus Controller notifies the UPA interface to advance PIO_HDR FIFO and begins processing the next request.

- b. The Bus Controller inserts the P_REPLY packet from PIO decoder into P_REPLY FIFO in the UPA interface.
6. UPA interface sends the P_REPLY packet.
7. UPA interface receives S_REPLY from the SC to tell U2P to source the data from PIO_RD FIFO.
8. PIO read data is sourced from PIO_RD. PIO read transaction is complete as far as U2P concerned.

IOMMU

The IOMMU performs virtual to physical address translation during DVMA cycles. PCI master devices provide 32-bit virtual address at the beginning of a DVMA transfer. The IOMMU translates them into 41 bits of physical address.

The IOMMU consists of a 16-entry fully-associative TLB (Translation Lookaside Buffer) implemented in the U2P ASIC and a TSB (Translation Storage Buffer) which is a software managed data structure (one-level) in main memory. Hardware performs TSB lookup (also known as a hardware table walk) when the translation cannot be found in the TLB. The TLB stores recently used translation information. An error is returned to the PCI master device if TSB lookup fails to locate a valid mapping.

The U2P IOMMU supports two different page sizes, 8K and 64K. Mixed page sizes can be used in the system, but in that case the TSB table lookup only assumes the smaller page size. No overlapping of pages is allowed. Bypass operation is supported to allow devices having their own translation facility to bypass IOMMU.

This chapter provides a high level description of IOMMU operations.

5.1 Block Diagram

One IOMMU provides translation for both PCI Buses (A & B).

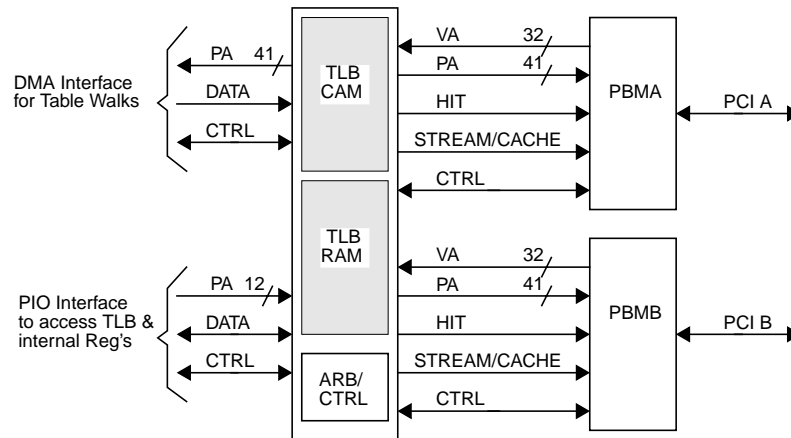

Figure 5-1 IOMMU top level block diagram

5.2 TLB Entry Format

A TLB entry consists of TLB tag in the CAM and TLB data in the RAM.

5.2.1 TLB CAM Tag

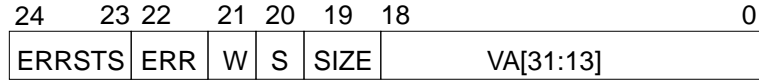

Table 5-1 Description of TLB Tag Fields

Field	Bits	Description	Type
ERRSTS	24:23	Error Status: 00 = Protection Error, 01 = Invalid Error, 10 = Time Out Error, 11 = ECC Error (UE).	RW
ERR	22	When set to 1 indicates that there is an error associated with this entry	RW
W	21	Writeable, when set, the page mapped by this TLB has write permission granted.	RW
S	20	Stream bit to determine stream vs. consistent access.	RW
SIZE	19	0 mean 8K page, 1 means 64K page.	RW
VA [31:13]	18:0	19-bit VPN (Virtual Page Number)	RW

5.2.2 TLB RAM Data



Table 5-2 TLB Data Format

Field	Bits	Description	Type
V	30	Valid bit, when set, the TLB data field is meaningful.	RW
RESERVED	29	RESERVED	
C	28	Cacheable bit. 1=Cacheable access, 0=Non-cacheable.	RW
PA[40:13]	27:0	28-bit Physical Page Number	RW

5.3 DVMA Operation Modes

U2P IOMMU operates in three different DVMA modes: translation, bypass, and pass-through. Its operation mode is determined by the value of “MMU_EN” bit of IOMMU Control Register, PCI addressing mode used: 64 bits Dual Address Cycle (DAC) vs. 32 bits Single Address Cycle (SAC), and PCI virtual address (bit 31 in SAC mode, bits 63:50 in DAC mode).

Table 5-3 PCI DVMA Modes of Operation

Mode	Addr<31>	MMU_EN	Addr<63:50>	Result
SAC	0	X	N/A	PCI peer-to-peer (Ignored by U2P)
SAC	1	0	N/A	Pass-through
SAC	1	1	N/A	IOMMU Translation (DVMA)
DAC	X	X	0x0000-0x3FFE	Ignored by U2P
DAC	X	X	0x3FFF	Bypass (DMA)

5.3.1 Translation Mode

Translation is initiated by the PBM block (PBMA or PBMB) by providing a 32-bit virtual address. The IOMMU hardware performs a TLB lookup first. If the lookup results in a TLB hit, the IOMMU returns a 41 bits physical address to the PBM block. If a TLB miss happens, hardware will start a TSB lookup unless the streaming cache lookup resulted in a hit (see hardware section for details on launching a table walk). If TSB lookup locates a valid mapping for the virtual page, information in the TSB entry will be loaded into TLB and translation continues. If TSB lookup results in a miss, an error will be returned to the PBM.

The virtual address consists of two fields, virtual page number and page offset. Page offset stays the same from virtual address to physical address. The conversion of virtual address to physical address for page sizes 8K and 64K is shown below.

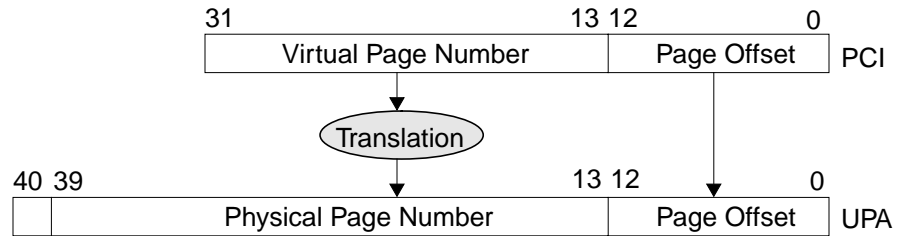

Figure 5-2 Virtual to physical address translation for 8K page size

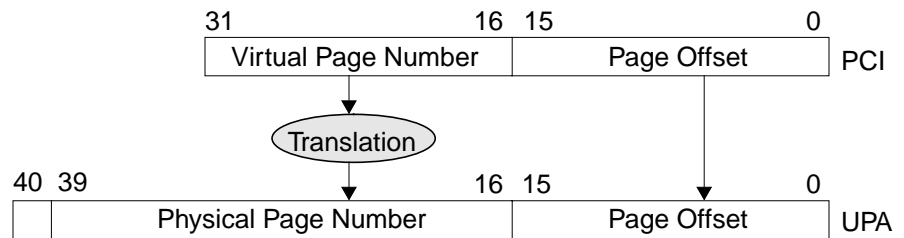

Figure 5-3 Virtual to physical address translation for 64K page size

5.3.2 Bypass Mode

The implementation of U2P IOMMU allows PCI devices to have their own MMU and bypass the IOMMU supported by the system. A PCI device is operating in bypass mode if all conditions in the last row in Table 5-3 are met. In this mode UPA physical address PA[40:0] = PCI_ADDR[40:0].

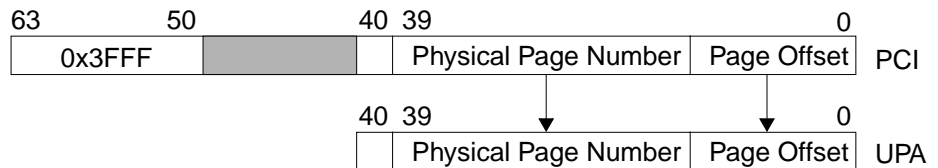

Figure 5-4 Physical address formation in bypass mode (8K and 64K)

A PCI device operating in bypass mode has direct access to the entire physical address space. Bit 40 of PCI_ADDR indicates whether the PCI device is accessing the coherent space (PA[40] = 0) or the IO space (PA[40] = 1).

5.3.3 Pass-through Mode

The IOMMU operates in pass-through mode if all conditions in the second row in Table 5-3 are met. Pass-through mode allows access to 2 GB of memory address space. If the higher 10 bits of physical address are padded with 0. A DVMA access in pass-through mode will always be to the coherent space.

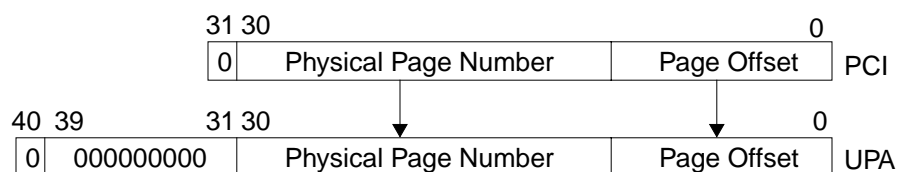

Figure 5-5 Physical address formation in pass-through mode (8k and 64K)

5.4 Translation Storage Buffer

Translation Storage Buffer, or TSB, is a translation table in memory. It contains one-level mapping information for the virtual pages. IOMMU hardware will look up this table if a translation cannot be found in the TLB. A TSB entry is called Translation Table Entry, or TTE, and takes 8 bytes.

Several TSB table sizes are supported in the system. The size of the TSB table is specified by the TSB_SIZE field of IOMMU Control Register. TSB table sizes supported are 1K, 2K, 4K, 8K, 16K, 32K, 64K and 128K entries (not bytes). This gives support for DVMA address space of 8M to 1G for an 8K page, and 64K to 2G for a 64K page (128K and 64K TSB sizes are not supported with 64K page). Software must set up TSB before it allows translation to start.

5.4.1 Translation Table Entry

Translation Table Entries (TTE) contain translation information for virtual pages. The IOMMU hardware reads one TTE during a table walk and stores it in the TLB. A TTE entry has valid information only when bit “DATA_V” is set. Information stored in the TTE is shown in the following table.

Table 5-4 TTE Data Format

Field	Bits	Description
DATA_V	<63>	Valid bit (1 = TTE entry has valid mapping)
DATA_SIZE	<61>	Page size of the mapping (0 = 8K, 1 = 64K).
STREAM	<60>	Stream bit (1 = streamable page, 0 = consistent page).
LOCALBUS	<59>	Local Bus bit. Not used.
DATA_SOFT_2	<58:51>	Reserved for software use
DATA_PA	<40:13>	Contains bits <40:13> of physical address. Bits 15:13 are not used for 64K page.
DATA_SOFT	<12:7>	Reserved for software use.
CACHEABLE	<4>	Cacheable (1 = cacheable page, 0 = non-cacheable page).
DATA_W	<1>	Set if this page is writeable

Caution – “LOCALBUS” bit is not stored in the TLB. The MMU hardware drops this bit after a table walk.

5.4.2 TSB Lookup

During the TSB lookup physical address for the TTE entry is formed based on the following information.

- Base address of the TSB table.
- Assumed page size during TSB lookup (as specified by TBW_SIZE bit in IOMMU Control Register).
- Size of TSB table.

TSB Base Address Register contains physical address of the first TTE entry in the TSB table. Lower order 13 bits of this register are all zeros because the TSB table must be aligned on 8K boundary regardless of TSB size. Physical address for an

entry in TSB table is formed by adding the base address and an offset generated as shown in Table 5-5. The lower order 3 bits of the offset are set to 0x0 because each TTE entry is 8 bytes in size.

Table 5-5 Offset to TSB Table

TSB Table Size	N	Offset (8K TSB lookup page size) (TBW_SIZE=0)	Offset (64K TSB lookup page size) (TBW_SIZE=1)
1K	12	[VA<22:13>, 000]	[VA<25:16>, 000]
2K	13	[VA<23:13>, 000]	[VA<26:16>, 000]
4K	14	[VA<24:13>, 000]	[VA<27:16>, 000]
8K	15	[VA<25:13>, 000]	[VA<28:16>, 000]
16K	16	[VA<26:13>, 000]	[VA<29:16>, 000]
32K	17	[VA<27:13>, 000]	[VA<30:16>, 000]
64K	18	[VA<28:13>, 000]	Not allowed ¹
128K	19	[VA<29:13>, 000]	Not allowed ¹

1. The MMU returns an error if it detect illegal combinations.

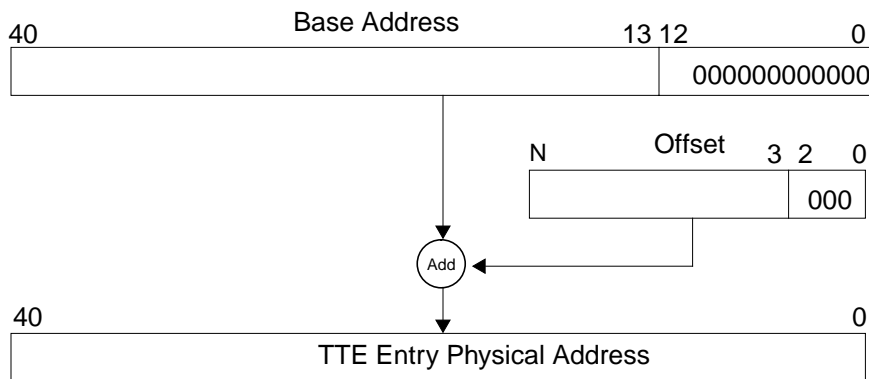

Figure 5-6 Computation of TTE Entry Address

TBW_SIZE should be set to 0 if 8K page size or mixed (8K and 64K) page sizes are used for DVMA mappings. If mixed page sizes are used, each 64K page will use up 8 entries of TTE. Software must fill all 8 entries with the same information. TBW_SIZE should be set to 1 if 64k page size is used for DVMA mappings.

5.5 PIO Operations

To prevent random PIO operations from interfering with the internal states of the translation, IOMMU implements some interlocking mechanism. The mechanism is described below.

- PIO operations to the IOMMU are held off during address translation.
- PIO operations to the IOMMU are held off during service of TLB Miss.
- If there is a pending PIO request, the IOMMU will begin the PIO operation once it completes the current translation or TLB miss service. In other words, when IOMMU is in idle state, it gives higher priority to PIO requests than address translations.

5.6 Translation Errors

Translation errors detected by the IOMMU are:

- **Invalid Errors.**

An invalid error happens if bit `DATA_V` in the TTE read by IOMMU hardware indicates that the TTE is invalid (`DATA_V = 0`).

- **Protection Error.**

A protection error is detected if the PCI device is doing DVMA write to a page which is mapped as read-only (bit `W = 0` in the TLB tag or bit `DATA_W = 0` in the TTE).

- **ECC Error.**

If a correctable ECC error occurred during table walk, the ECC unit will correct the error and the TTE received by the IOMMU is error free. If the ECC error is uncorrectable, the received TTE will be invalid and the IOMMU will flag an error.

- **Time Out Error.**

A time out error is a result of a time out on the UPA interconnect during a table walk.

- **Out-Of-Range Virtual Address Error.**

The combination of `TSB_SIZE` and `TBW_SIZE` determines the range of valid virtual addresses as described in Table 13-28 in the Programmer's Model Chapter. The MMU returns error if it detects any out-of-range virtual address. The MMU also return an error if it detects illegal combinations of `TSB_SIZE` and `TBW_SIZE`.

Errors detected by the IOMMU will be reported to the requesting PBM immediately after detection if the PBM is still connected. Under certain conditions the PBM can disconnect after a table walk is initiated. In such cases an error bit along with 2-bit error status (see Table 5-1) are loaded along with the received TTE.

5.7 IOMMU Demap

After the mapping between virtual address and physical address spaces is established, any change to the mapping information needs to demap the existing mapping before a new mapping can be used by the device. Demap is required for the following occasions: taking down existing mapping to make physical memory available to other virtual addresses, or changing access permission to a page.

During an IOMMU demap, the PCI device is not allowed to use the page that is being demapped. If a device tries to access a page that is being demapped, unexpected results may happen. The following events are needed to demap a page in the IOMMU.

- Update proper TSB entry with new information.
- Perform TLB flush with virtual page number.
- Flush the streaming cache if the page is marked streamable.

TLB flush is initiated by writing to IOMMU Flush Address Register with specified virtual page number. Match criteria are different for 8K and 64K page sizes. Hardware performing the flush will adjust the match criteria based on the page size. The matched entry in the TLB will be marked invalid.

5.8 TLB Initialization and Diagnostics

IOMMU provides direct access to its internal resources, such as TLB Tag, TLB Data, LRU Queue and Match Comparison Logic. Please see the hardware and the programmer's model sections for more details.

After power is turned on, all TLB entries are invalid. Before any DVMA is allowed to proceed, software may want to ensure that none of the entries is marked valid as a result of the diagnostic operations during booting. This is done by writing "0" to the "V" bit in every entry of TLB Data RAM.

PCI Bus Interface

6.1 Introduction

This chapter describes the PCI Bus interface block of U2P. It goes by the abbreviation “PBM” for ‘PCI Bus Module’. It is a host-PCI bridge and can be instantiated alone or as a pair of peer Host-PCI bridges. In U2P two PBM’s are used to interface to two PCI bus segments. The A segment is a 64-bit wide, 33/66MHz capable PCI bus which supports 4 external master devices, and the B segment is a 64-bit wide, 33MHz capable PCI bus which supports 6 external master devices. Both segment clocks are synchronous to the internal 66MHz clock. The PBM’s main features are:

- Compliant with PCI Local Bus Specification, version 2.1.
- Operates with a PCI clock rate of either 1X or 0.5X the internal clock rate.
- Internal interfaces to:
 - Streaming Cache.
 - IOMMU.
 - UPA Interface & Merge Buffer.
 - Mondo Interrupt Controller.
- Dual 64-byte DMA write buffers, single 64-byte DMA Read buffer, and a single 64-byte PIO write buffer.
- Little-endian access to the bus and to internal configuration space.
- Source configurable for a 32- or 64-bit PCI data bus - same source code for both segments.

6.1.1 Supported PCI features:

- 64-bit Bus Extension (as a target only, for DMA, not as master for PIO).
- 64-bit Addressing (Dual Address Cycle) for IOMMU bypass.
- Required adapter and host-bridge configuration space header registers.

- Fast Back-to-Back cycles as a target.
- Arbitrary byte enables (Consistent mode only).
- Ability to generate memory, I/O, and configuration read and write cycles.
- Ability to generate special cycles.
- Responds only to memory space accesses.
- Peer-to-peer DMA on a single segment.

6.1.2 Unsupported PCI features:

- Exclusive Access to main memory (LOCK).
- Peer-to-peer DMA between different PCI bus segments.
- Local (on-PCI) cache support.
- External arbiter.
- Cache-line Wrap Addressing Mode.
- Fast Back-to-Back cycles as a PIO master.
- Address/Data Stepping.
- Subtractive decode.
- Any DOS compatibility features.

6.2 PCI Bus Operations

6.2.1 Bus Master Operation (PIO)

Read and write transactions occur as specified in the PCI specification but are also described here for completeness. Figure 6-1 illustrates a read transaction. Figure 6-2 illustrates a write transaction.

U2P is capable of generating aligned PIO reads of 1,2,4,8,16, and 64 bytes to memory space and 1,2, and 4 byte accesses to I/O and configuration space. It is also capable of generating PIO writes with arbitrary byte enables with 0-16 bytes transferred to memory space, and 0-4 bytes transferred to I/O or configuration space. In addition, 64-byte PIO writes with all bytes enabled can be generated to memory space. PIO write data is posted to the 64B write buffer to be dispatched by the PBM which handles target retries and disconnects transparently to other control blocks. PIO read data is loaded directly from the PCI bus to U2P's internal bus in 64-bit quantities.

The PBM cannot generate 64-bit PIO cycles nor PIO's with Dual Address Cycles

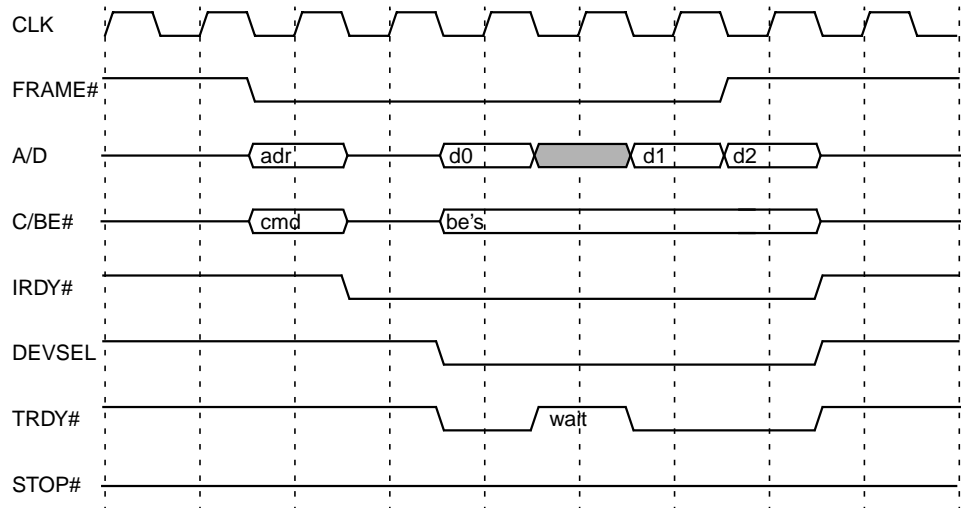

Figure 6-1 Basic PCI Read Transaction

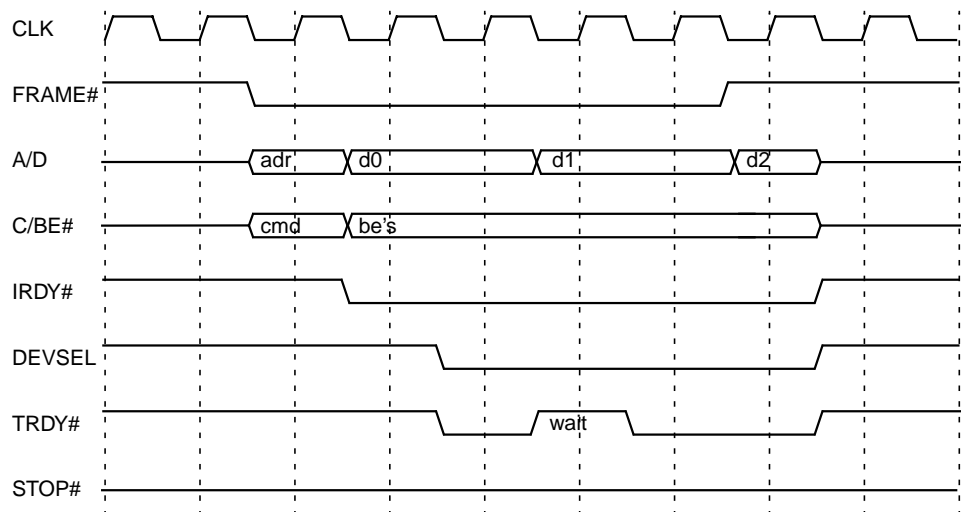

Figure 6-2 Basic PCI Write Transaction

Errors on PIO writes are handled asynchronously; status is logged in the AFSR and configuration status registers, and address is logged in the AFAR. Errors on reads are returned to the processor synchronously.

6.2.2 Target Operation (DMA)

The PBM handles both consistent and streaming mapped DMA. The PBM responds with medium DEVSEL# timing (2 clocks) to any PCI address with A/D[31] equal to a 1. The PBM resolves the address before asserting TRDY# to the master. Address resolution is done by either the IOMMU translating the address, or by hitting the Streaming Cache. Errors or “busy” signals from either of these units may be communicated back to the master device via target-aborts or retries. DMA errors are the responsibility of the bus master so no interrupts are issued, however status is logged in the configuration status register.

Address resolution may also occur in two other ways; Bypass, which occurs on Dual Address Cycles (DAC), wherein a valid 64-bit physical address is provided by the master, and Pass-through, where the IOMMU is disabled and the physical address is composed by bit extending the 32-bit address PCI address with zeroes. To avoid claiming the entire 64-bit PCI address space, U2P responds only to DAC's where the top 14 bits of address are ones.

DMA writes are posted to dual 64B buffers. One buffer can drain to U2P's internal data bus while the other is filling from the PCI bus. Byte enables are stored along with the data. DMA reads are singly buffered in the PBM to insulate the internal data bus from disconnects and pauses due to master wait states, master latency time-outs, slower bus speeds, and narrower bus width.

When a DMA burst transfer attempts to go past a cache line (64B) boundary, U2P generates a disconnect. This should cause the master device to attempt the transaction again beginning at the address of the next untransferred data.

Arbitrary byte enables are supported for Consistent DMA transactions. In Streaming mode, U2P only supports contiguous byte enable patterns: if a *byte hole* is encountered in streaming mode, U2P will complete the transaction but the data for those disabled bytes will be unknown. If enabled, the PBM will generate an interrupt and set a status bit indicating the detection of a byte hole. A byte hole is defined as any byte enable pattern in a single bus transaction which would cause a byte to not be written while writing bytes both before and after it. Byte holes that are a result of two separate bus transactions do not cause any errors in either consistent or streaming mode.

Any DMA transaction which requests 64-bit data transfer will receive a 64-bit acknowledgment from U2P.

6.2.3 Transaction Termination Behavior

6.2.3.1 Retries

A *retry* is depicted in Figure 6-3. A count is kept of the number of retries for a given PIO transaction. When this value exceeds the Retry Limit Count the PBM ceases to attempt the transaction and issues an interrupt to the processor. The Retry Limit Count is fixed at 16,384.

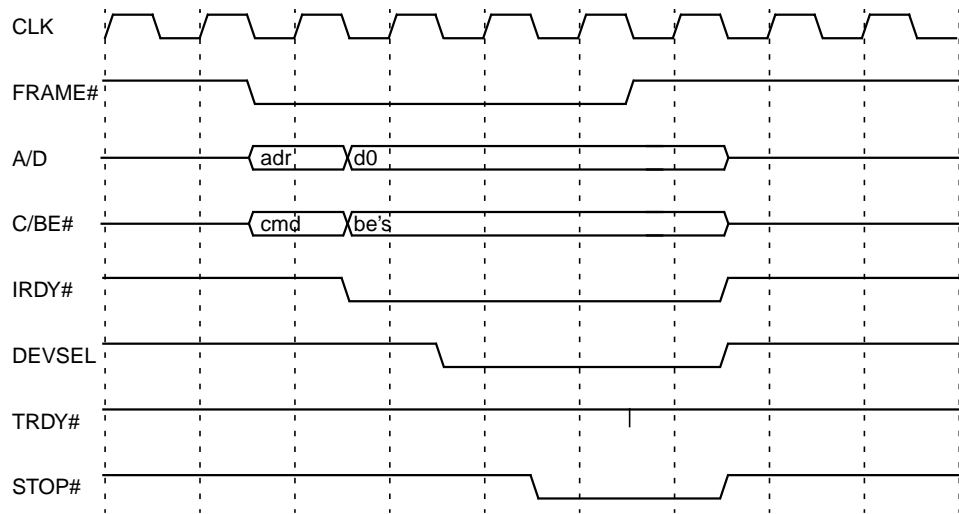

Figure 6-3 Retry Cycle

For DMA, U2P can generate retries at the request of the streaming cache, for consistent reads which miss the IOMMU, and when the DMA write buffers are full.

6.2.3.2 Disconnects

A PBM *disconnect* is depicted in Figure 6-4. As a target, the PBM only disconnects at line boundaries. No count is kept of disconnects.

6.2.3.3 Master-aborts

A *master-abort* is depicted in Figure 6-5. This is the case when no device responds to the PIO address.

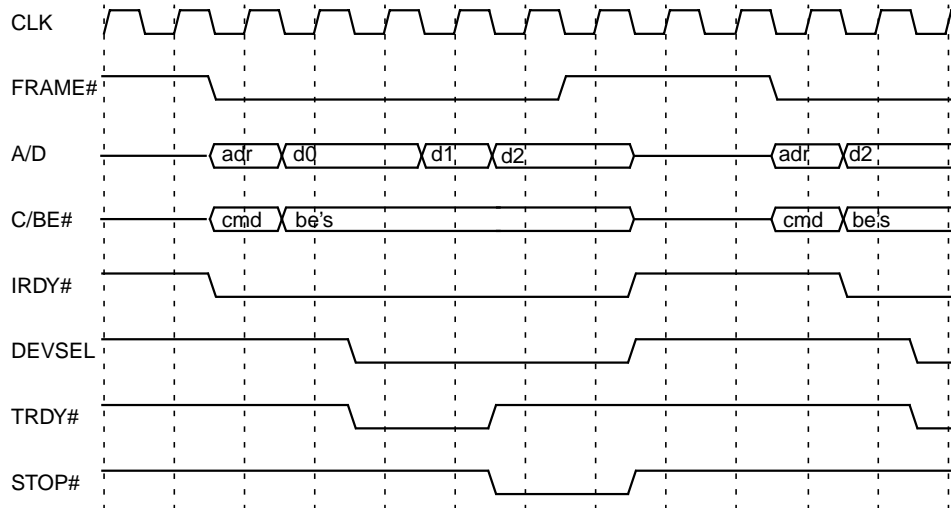

Figure 6-4 Disconnect Cycle

6.2.3.4 Target-aborts

A *target-abort* is depicted in Figure 6-6. A target-abort may be received for a variety of error conditions and may be generated by U2P for illegal addresses, address parity errors, and protection errors. All cases for which U2P may signal a target-abort are given in Chapter 11.

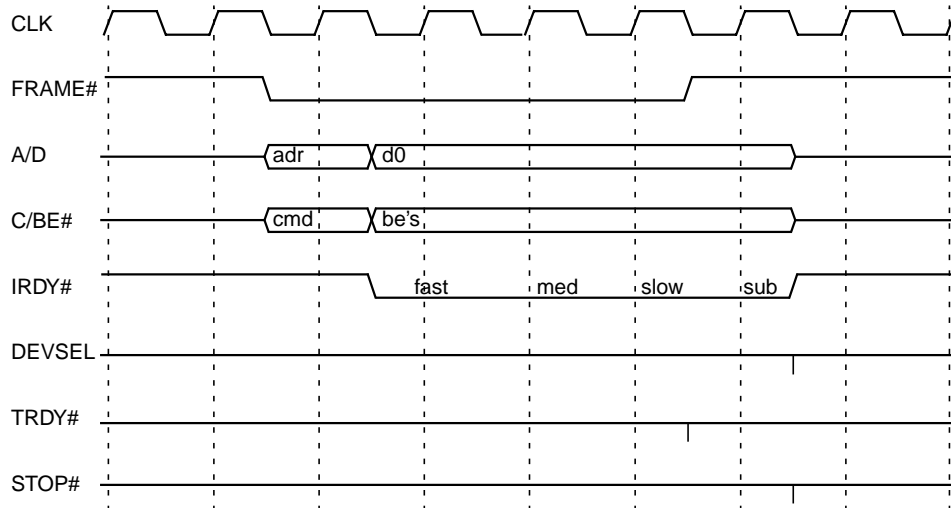

Figure 6-5 Master-abort Cycle

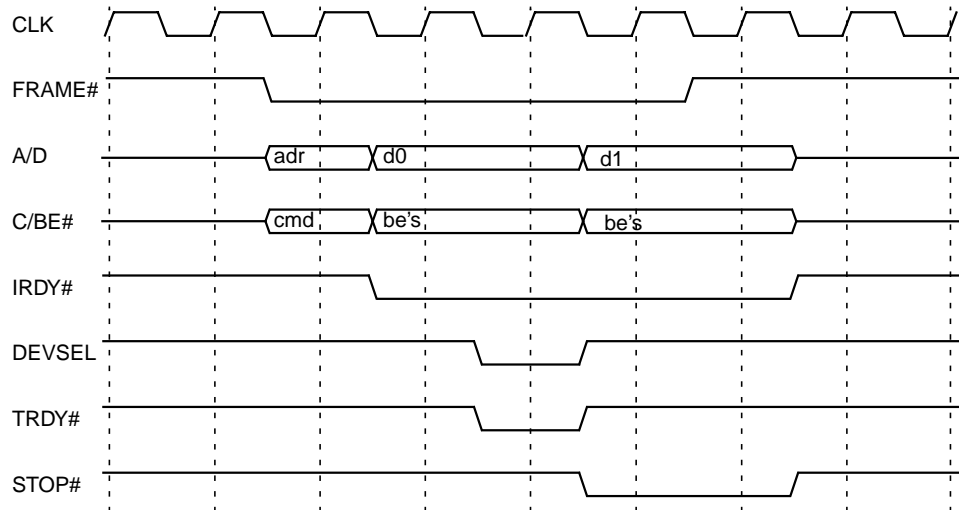

Figure 6-6 Target-abort Cycle

6.2.4 Addressing Modes

Only the Linear Incrementing addressing mode is supported. Reserved and Cache Line Wrap address mode accesses are disconnected after the first data phase, allowing the master to complete the transfer one data word at a time.

6.2.5 Configuration Cycles

U2P can generate both Type 0 and Type 1 configuration accesses. The type generated depends on the bus number field within the configuration address and the bus number and subordinate bus number registers in the bridge configuration header. See Section 13.2.2.1, "PCI Configuration Space" for details.

6.2.6 Special Cycles

A PCI special cycle is shown in Figure 6-7. The PCI address is a don't care and the message (data written) is passed on the first data phase on AD[31:0]. No additional data phases may be generated. The cycle ends in a master abort with no error reported and the RMA status register bit not set.

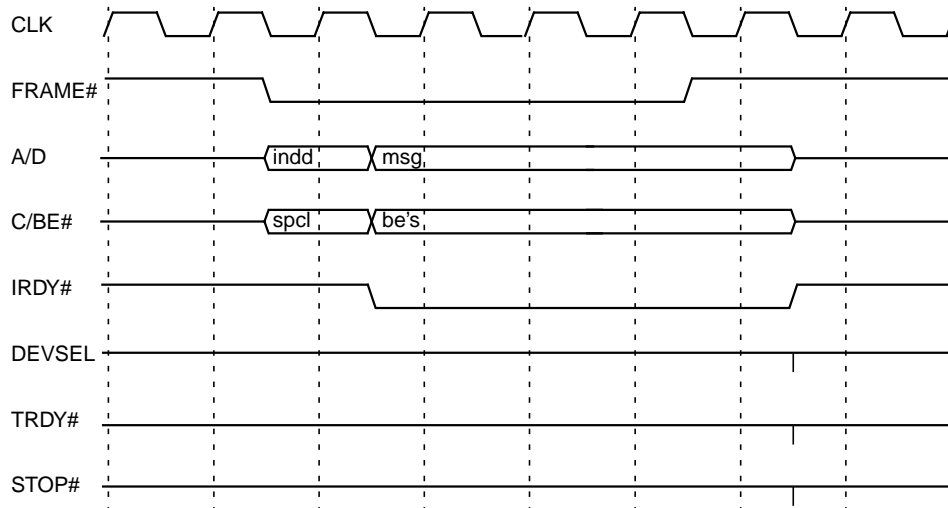

Figure 6-7 Special Cycle

6.2.7 Exclusive Access

U2P does not implement locking at all and the LOCK# signal is not connected. Any exclusive access will proceed as if it were a non-exclusive access.

6.2.8 Fast Back-to-Back Cycles

The PBM is capable of handling Fast Back-to-Back DMA transactions as a target device. The Fast Back-to-Back Capable bit in the Status register is hardwired to '1'. It handles the master-based mechanism (required) and is capable of decoding the target-based mechanism as well. The address is checked and masters presenting an invalid address receive a target-abort termination just as in the normal case. Figure 6-8 illustrates several Fast Back-to-Back cycles on a PCI bus. The specification requires that TRDY#, DEVSEL#, and STOP# be delayed by one cycle unless this device was the target of the previous transaction. This causes writes to be extended by a cycle but is hidden on reads.

The PBM is not capable of generating Fast Back-to-Back PIO transactions and does not implement the Fast Back-to-Back enable bit in the Command Register in the configuration header. A Fast Back-to-Back PIO would remove the idle cycle between

two transactions to the same target as long as the first transaction was a write. Observe that this feature would place the burden on U2P of knowing which device is targeted for each transaction.

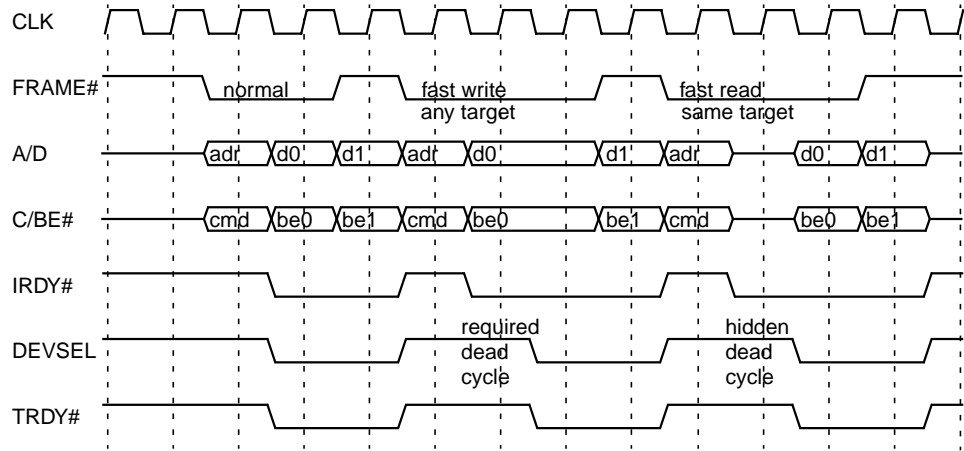

Figure 6-8 Fast Back-to-Back Cycles

6.3 Functional Topics

6.3.1 PCI Arbiter

6.3.1.1 Arbitration Scheme

The PBM provides the arbiter for its PCI bus segment. The arbitration scheme implemented is fair arbitration where all enabled requests are serviced in round-robin fashion.

6.3.1.2 Bus Parking

The ARB_PARK bit in the PCI Control Register causes the grant for the last active bus master to be asserted when no other requests are asserted. This results in a 1 clock savings for the parked device in the “cold-start” case, and a 1 clock delay for devices in other slots.

6.3.2 Endianness

U2P's main internal data busses are connected to the PBM in a "byte-twisted" fashion where the logical byte lanes are connected together. For byte 0, the U2P data bits [63:56] are connected to the PBM data bits [7:0], and so on. The PBM internal control registers, which are big-endian, are byte-twisted again internally.

6.3.3 PCI Commands

Table 6-1 defines the commands the PBM is able to generate as well as how it responds to all commands as a target.

Table 6-1 PCI Command Generation and Response

Command	C/BE#	Generate?	Response
Interrupt Acknowledge	0000	No	Ignored
Special Cycle	0001	Yes	Ignored
I/O Read	0010	Yes	Ignored
I/O Write	0011	Yes	Ignored
Reserved	0100	No	Ignored
Reserved	0101	No	Ignored
Memory Read	0110	Yes	Perform read access
Memory Write	0111	Yes	Perform write access
Reserved	1000	No	Ignored
Reserved	1001	No	Ignored
Configuration Read	1010	Yes	Ignored
Configuration Write	1011	Yes	Ignored
Memory Read Multiple	1100	No	Perform read (with prefetch if streamable)
Dual Address Cycle	1101	No	Bypass access
Memory Read Line	1110	Yes	Perform read (with prefetch if streamable)
Memory Write & Invalidate	1111	No	Equivalent to Memory Write command

6.3.4 Diagnostic Modes

U2P has the ability to count certain PBM operations such as tablewalks, retries due to tablewalks, and number of DMA bytes transferred, via the performance monitor block.

There is a diagnostic bit that puts the PBM interface in loopback mode. This results in all PIO being looped back through the DMA interface and back to memory. Any valid PIO cycle may be looped back in consistent, streaming, or pass-through mode.

There are three bits that invert parity generation for PIO address, PIO write data, and DMA read data individually. For the DMA read data PAR64 is also inverted.

6.3.5 Clocks

The clocks are driven from an external low-skew clock driver chip. This provides the PCI A and B clocks as well as the U2P source clock. All PBM internal registers are clocked by the internal 66MHz U2P clock, the PCI CLK signal is only used for reference, to determine bus speed (1X or 0.5X), and phasing.

PCI specifies a signal, "M66EN", which indicates the ability of all devices on the bus to run at 66MHz. To save a pin, U2P doesn't have M66EN as an input but instead samples PCI CLK with respect to the U2P clock to determine the correct state of M66EN.

6.3.6 Reset

The PCI reset line are driven as a function of the chip reset signal UPA_RST_L.

Streaming Cache Operation

7.1 Overview

The SStreaming Cache (STC) implemented in the U2P ASIC is a small size fully associative cache managed by both hardware and software, to accelerate certain PCI bus DVMA to and from system memory.

There are two STC modules instantiated in U2P, one for PCI bus A, and one for PCI bus B. This chapter specifies the size, functionality and algorithms of a single STC module, but the reader should realize that all statements can be applied to both instances, unless otherwise specified.

The U2P streaming cache performs three primary functions. The first is to accumulate sequentially addressed PCI write bursts into quantities the size of a system block. The second function is to speculatively prefetch the next (increasing) sequential block of memory for an active PCI read stream. The third function is to act as a local cache for PCI read accesses to the same block.

The implementation of the U2P streaming cache features:

- A fully associative pool of 16 entries shared among read and write streams.
- Dual ported data RAM for concurrent write/flush and read/fill operations.
- 64 bit wide interface to both the PBM and UPA modules.
- Least Recently Used entry allocation scheme.
- Virtual address tags for low lookup latency.
- Physical address page translation for each entry to reduce flush and prefetch latencies.
- One entry allotment per virtual page to reduce the problem of individual misbehaved devices from thrashing the cache.

- Individual byte write enables to support PCI bus byte granularity.

Only accesses to virtual pages that are designated by software as streamable pages can use the streaming cache's functions. The cache is located in non-coherent memory, therefore software intervention is required to ensure a consistent memory image. PCI devices will see program order functionality; reads followed by writes and writes followed by reads will see the correct results.

7.1.1 Streaming Cache Conceptual Overview

The streaming cache conceptually resides in close proximity to the PCI Bus Controller Module (PBM) so that low latency will be observed by the cards on each streaming access. A very tight coupling exists between the PBM and the streaming cache, with the STC almost appearing as a slave device to the PBM.

The streaming cache also has its own interface to the internal bus of the U2P. One reason is that the STC needs to pass different information to the DMA controller than the PBM. Another reason is that there are occasions when both the STC and the PBM would like to communicate with the UPA interface. The U2P internal bus controller can handle this arbitration more effectively than PBM controlled arbiter since it has superior knowledge of the resources available (merge buffer, UPA queue). Separate internal bus interfaces mean that streaming read replies will not be synchronized with the PBM; the data will first be placed into the cache and then the PCI bus can consume it.

IOMMU lookups are handled as a natural part of the PBM's functionality. The PBM will communicate all necessary information to the STC, therefore there is no direct connection between the STC and the IOMMU.

The STC is essentially a intermediate buffer for streaming data transfer between the UPA and PCI busses. There is no need for the STC to generate interrupts, therefore no connection to the Mondo Unit is necessary. Error information from the UPA on read replies will be stored in the STC to be used by the PBM at a later time. PCI parity error information on write requests will be stored in the STC and be used to corrupt the ECC of the outbound data.

7.1.1.1 STC Subsections

The streaming cache is partitioned into four major subsections: the STC Central Control Unit, the Tag block, the Data block, and the Master Request Port.

The STC Central FSM handles control signal communication between the STC and PBM module. It also, along with the Master request Port, handles STC communication with the U2P Bus Controller module (BCT).

The Tag block contains all of the address and status information concerning the entries within the cache. This includes the virtual page number, the corresponding physical page number, the byte locations of dirty data within a block, and the status of the line (invalid, fetching).

The Data block holds the actual data associated with the block of memory. It also contains error status in the form of 32 total bits, two bits per entry, one bit associated with PCI writes, one bit associated with PCI reads.

The Master Request Port handles most communication between the U2P internal bus structure and the streaming cache. It is responsible for posting DMA requests and subsequently sinking/sourcing data. To decouple streaming cache operation from the delays and protocol associated with using U2P's internal busses, the Master Request Port has both a 64-byte prefetch buffer and a 64-byte flush buffer.

7.2 Streaming Cache Functional Description

The STC is first consulted whenever a PCI DMA request occurs. The virtual address appearing on the PCI bus is compared with the VA tags to see if the page is streamable and active in the cache. If there is a hit, then the appropriate action is taken on the matching entry as described in the following paragraphs. If the virtual page is not found in the STC, then this initial transaction will be ignored and the internal state reset. A page not found in the cache does not mean that the page is not streamable; just that it is not active in the cache at this time. The PCI controller module will return if the results of the IOMMU lookup indicate that the page was indeed marked streamable. In this case, the least recently used entry will be allocated and its contents invalidated (if clean) or flushed to memory (if the contents are dirty).

7.2.1 Streaming Writes

The STC receives write data from the PBM and fills the appropriate cache line in the hopes of eventually accumulating an entire system block quantity of data. This block can then be sent to memory without having to perform a read-merge-write operation. If the write ends at a block boundary, then after the data is inserted into the cache, the entry will be copied into the 64-byte flush buffer, from which it will be copied to the UPA block as soon as allowed by U2P's Bus Controller. If the flush buffer is already full when a DMA write ends at a block boundary, the streaming cache will wait until the flush buffer begins emptying to the UPA, then it will transfer the entry to the flush buffer. During this wait, no further requests from the PBM will be acknowledged. This guarantees that all completed 64-byte blocks will be flushed without software intervention.

7.2.1.1 Byte Holes and Zero Byte Writes

Byte holes within a single PCI write data stream (i.e. byte enable bit is off, while byte enable to the left and right are on), and zero byte writes are defined to be an error condition if the page is marked streamable. The PBM detects these conditions, signals the DVMA master, and cleanly ends its transaction with the streaming cache.

7.2.2 Streaming Reads

Streaming reads fall into one of three categories; either the requested data is already located in the cache, the data must be fetched from memory, or the data is currently being fetched from memory.

If the data is in the cache, and the last byte of the block will not be read, then the data is simply fed to the PCI device. If the last byte is expected to be read, as signalled by the PBM when it services a PCI Memory Read Line or Memory Read Line Multiple command, then a prefetch of the next increasing sequential block of memory will also be attempted, as long as there is not already an outstanding prefetch request. If the master request port is not busy, the prefetch will be launched immediately, otherwise the fetch will try to occur after the data is provided to the PCI device. When the prefetch data arrives, it is put into the prefetch buffer. As soon as the Data Block is not busy, the prefetch data is copied to it, provided that the last word of the line being overwritten was really read by the PCI device. If the PCI device did not access the last word (even though it issued a Memory Read Line or Memory Read Line Multiple command), the prefetch (and some UPA bandwidth) will be wasted. A prefetch can also be issued if the PCI device reads the last word of a line. This covers the normal PCI read case (i.e. the op is not a Memory Read Line or Memory Read Line Multiple).

If the data is not in the streaming cache (either the page or the line is not valid in the cache), then the data must be fetched from memory. The entry will be allocated by the fetch and marked as fetch outstanding. A demand fetch is then posted. In this scenario, the PCI controller will be informed that the PCI device should be retried. This is done to free up the PCI bus to perform other transactions during the memory read latency.

If the PCI device hits on an entry in the cache that is currently marked fetch outstanding, the streaming cache will wait while the fetch completes, then proceed as above.

7.2.3 Entry Flushing

There are several occasions when an entry containing dirty data needs to be flushed toward coherent memory. These are:

- End of line flush: When a DVMA write reaches end of a cache line, the hardware will perform a line flush if the flush buffer is available, or wait until the flush buffer is available and then perform the flush.
- Non-sequential write to the same line: Any non-sequential write to a cache line will cause the existing line to be flushed before new data can be accepted.
- Line eviction on the same page: If a line is partially filled and is dirty and the device starts writing to a new line on the same page, buffered data for the previous write has to be flushed before new data can be accepted.
- Line eviction different page: This happens when all the cache lines are used up and the incoming DVMA accesses a page with no line allocated to it. If the LRU line has dirty data, it needs to be flushed before the line can be allocated to a new page.
- Read from page currently mapped for Writes: If a DVMA read occurs to a cache line currently being used for writes, and the line is dirty, then the buffer must be flushed before the read data is accepted.
- Software triggered flush: Software needs to flush the Streaming Buffer cache line on any DVMA write transfers which end on sub-line boundaries.

Of the preceding, only the software triggered flush is visible to the software.

To make sure all previous flush operations are completed at the coherence domain, U2P provides a mechanism to synchronize the flush operation. The flush synchronization involves a PIO write to the Streaming Buffer Flush Synchronization Register with the physical address of the flush flag provided as PIO write data. Only one write of the synchronization register is required as a barrier for all previous flush/invalidate writes to that streaming cache.

In all of the mentioned cases, it is possible that the entry may not contain an entire system block of data to be written to memory. This situation requires a sub-block to be delivered to the Merge Buffer block, whereupon the sub-block can be merged with the rest of the block of coherent memory.

7.3 Streaming Cache Programming Model

7.3.1 Performance Issues

Extracting the most performance out of the streaming cache involves following several guidelines concerning DMA accesses. Not prescribing to these guidelines will result in less than ideal observed performance. Some access patterns may, in fact, incur a penalty which causes the streaming cache to yield poorer performance than equivalent non-streamable accesses.

DMA Writes

DMA writes to a block within a streamable virtual page should always access memory in increasing total sequential order (i.e. no gaps). Failure to do so will cause unnecessary flushing of the cache entry (and byte holes within a single DMA write will cause errors). Better performance is exhibited when writing large sized bursts (32 to 64 bytes). While writes within a block should be increasing and sequential, no hardware imposed performance impact is made in regard to accesses across blocks or pages.

DMA Reads

DMA reads from a block within a streamable virtual page should access memory in increasing sequential order, and should use the appropriate PCI bus commands based on amount of data to be read. Failure to do so will cause unnecessary prefetching.

U2P always disconnects from the PCI bus at 64 byte boundaries. Optimum performance is achieved by using PCI Memory Read Line or PCI Memory Read Line Multiple (treated the same by U2P) in conjunction with 64 byte accesses. If a transfer will not be reading to an aligned 64 byte boundary it should use the Memory Read command and not the Read Line commands. Failure to adhere to this method can result in extra UPA prefetching and PCI bus Retrys occurring on every other transaction.

Reads across blocks should also be in increasing and sequential order. Failure to do so will waste the prefetching, reducing the maximum read bandwidth to no more than non-streaming reads. Prefetches are not launched if they would cross a page boundary.

Since there is only one entry allotted per virtual page, multiple devices should not interleave their accesses to the same virtual page. If it is desired to have multiple devices accessing non-overlapping portions of the same page, aliasing should be used to map different virtual pages to the same physical page.

7.3.2 Memory Coherency Maintenance

The streaming cache resides outside of the coherent memory domain, therefore it must rely on software maintenance to guarantee correctness to the PCI devices. Two mechanisms have been defined to provide software access to the operation of the streaming cache.

The first means of software maintenance is the “page invalidate/flush” command (henceforth referred to simply as flush command). Software can issue a flush command to force the streaming cache to remove any entry that matches the indicated virtual page. If the page contains dirty data, a DMA write will be issued to flush the data to memory. Regardless of the contents of the entry, both the virtual page entry and its corresponding physical page translation will be invalidated from the cache. De-mapping a streamable page must involve flush command(s) to the streaming cache to ensure a valid virtual to physical page translation.

The flush command is enacted by performing a PIO write of the appropriate virtual page to the streaming cache flush port. Multiple page flush commands are allowed to be outstanding at anytime. The PIO writes will be serviced in the order received by the cache.

Note – The streaming cache considers all pages to be 8K in size, therefore virtual pages to be flushed need to have bits 31 through 13 to be significant. When dealing with a 64K page size, eight separate flush commands will have to be issued to ensure that the entire 64K page is consistent between memory and the streaming cache.

The second mechanism provided for software to help maintain the cache is a means to synchronize with the DMA flush stream. The positive acknowledge to the PIO write command on a flush operation is not sufficient to indicate whether the data from the appropriate virtual page has been flushed all the way into the coherent memory domain. There is no ordering enforced between the PIO and DMA datapaths; the data from the cache entry can reside in an intermediate write buffer for an unknown period of time after the PIO acknowledge has been received by the processor. The “synch” command has been created to properly inform software when the flush data has actually reached the coherent domain. The command is launched by issuing a PIO write to the streaming cache synch port with a (block

aligned) physical address pointer. The cache will subsequently launch a DMA block write (data = 0x00000000 00000001, 0x0) to the supplied physical address to indicate that the flush operation has completed.

Since PIO accesses are serviced by the STC in the order received, and write requests across the U2P are strongly ordered, only one synch operation is needed to indicate that all previous flush commands for a particular streaming cache have completed and their data has entered the coherent memory domain.

7.3.3 Error Recovery

Whenever any DVMA read results in a UPA error (including uncorrectable ECC errors), the corresponding virtual page must be invalidated in the streaming cache. In some cases, software will only be provided with the physical address of the erroneous location. It is software's responsibility to determine the virtual page(s) that correspond to the error and subsequently invalidate them. Failure to conform to this procedure will result in a PCI device to be continuously error acked due to the presence of the error bit in the streaming cache entry. In the case of an uncorrectable ECC error, no further interrupts will be launched by the ECC unit, and the (stale) entry will most likely never be replaced in the cache (on its own, by a prefetch) since it will be continually accessed and error acked.

No software intervention is required for DVMA write errors. These errors (which are the result of PCI parity errors) cause bad ECC to be written back to memory when the bad entry is flushed. Since flushing invalidates the line the error will not repeat.

Mondo Dispatch Unit

This chapter describes the Mondo Dispatch Unit (MDU) which handles interrupts from the PCI bus, other external sources and U2P internal sources.

8.1 Overview

The Mondo interrupt transfer mechanism used by UltraSPARC systems is designed to reduce interrupt service overhead through the use of processor and system-based supports. On the processor side, SPARC V9 CPUs will provide a dedicated set of registers to be used exclusively for servicing interrupts. This eliminates the need for the processor to save its current register set to service an interrupt, and then restore it later. On the system side, requests for interrupt service are converted into interrupt request packets which are sent over the memory interconnect to the processor. An interrupt packet contains a Mondo vector which has three double words designed to assist the processor in servicing the interrupt.

Limitations of the Mondo vector approach include: Only one interrupt request packet can be in serviced at a time. There is no priority level associated with Mondo vector interrupts; they are serviced on first come, first served basis. Flow control must be done at the interconnect level to prevent loss of interrupt packets.

8.1.1 Mondo Dispatch Overview

The Mondo Dispatch Unit is responsible for fielding interrupts from external PCI sources, other external sources, and internal U2P sources, building the UPA Interrupt packet, and sending the interrupt packet to the appropriate CPU.

External interrupt sources include 6 PCI slots (four separate interrupts each) on two separate PCI busses, the onboard IO devices, a graphics interrupt, and the expansion UPA slot. These interrupts are concentrated in an external ASIC and are presented to the Mondo Unit one at a time. Internal interrupt sources include the ECC (errors), PBMA & PBMB (PCI bus errors), Timer/Counters, and the Power Management Wakeup interrupt (which combines wakeup interrupts from the Timer, PBMA and PBMB). These sources are discussed in further detail later in this chapter.

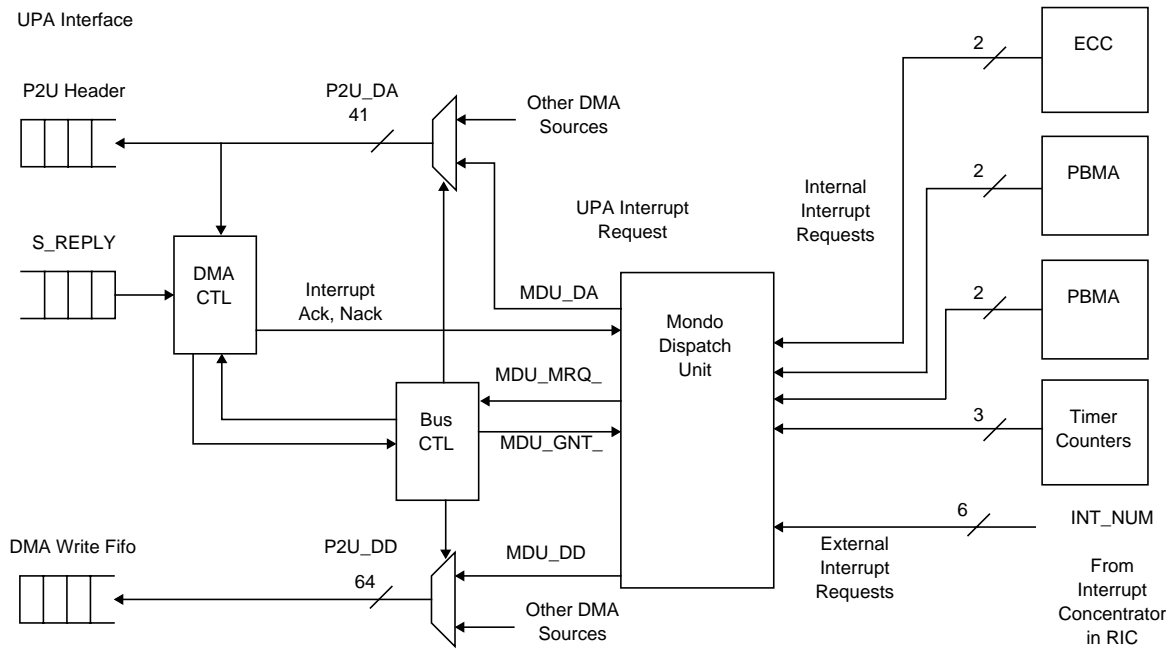

Figure 8-1 Mondo Dispatch Unit in U2P

8.1.2 Mondo Dispatch Block Diagram

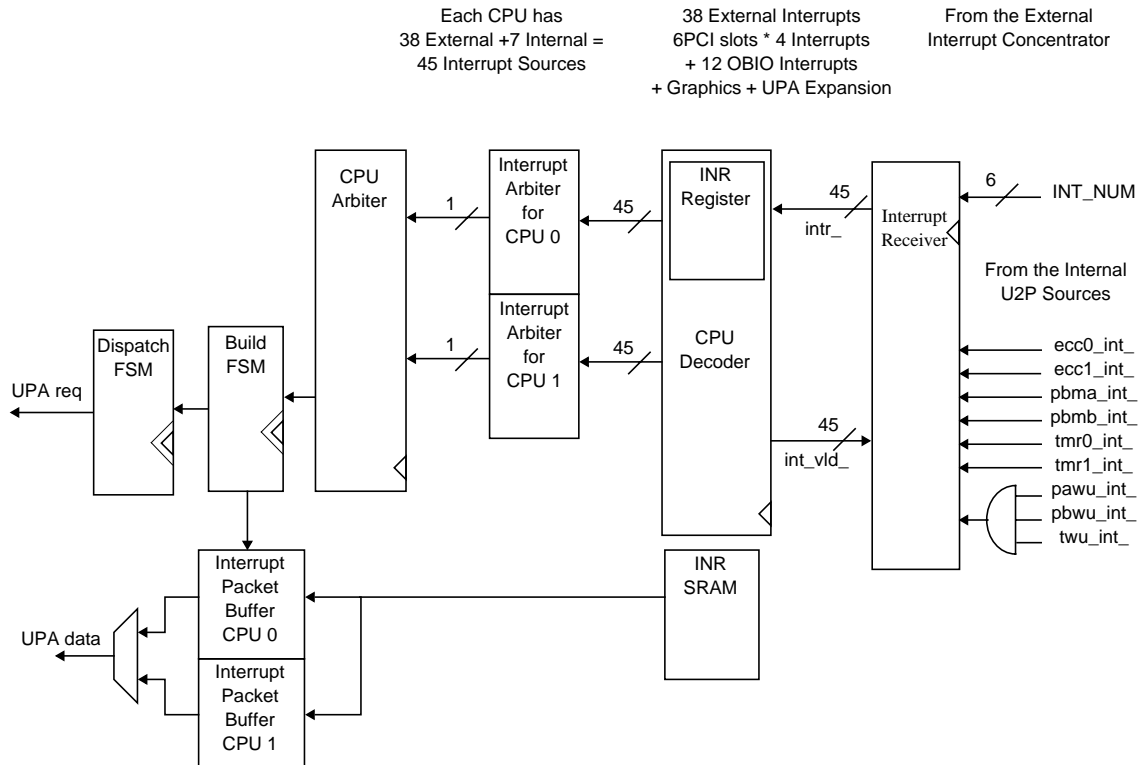

Figure 8-2 Mondo Dispatch Overview Block Diagram

The figure above shows the general flow through the Mondo Dispatch Unit. Each triangle in a block indicates a clock cycle of latency. Thus, the overall latency through the Mondo Dispatch Unit from the External Interrupt Concentrator to issuing the request to the internal U2P Bus Controller is 6 cycles.

8.2 Mondo Unit Functional Description

The Mondo Unit is responsible for generating a UPA Mondo Vector Request Packet for interrupt clients. This section contains the following:

1. An overview of Mondo Interrupts.

2. Interrupt Types.
3. Flow of an interrupt through the Mondo Dispatch Unit.

8.2.1 Mondo Vectors

Before a functional discussion on the Mondo Dispatch Unit, it is necessary to provide a brief overview of Mondo Vectors. Refer to Sun-4U Architecture Specification for a more detailed description.

8.2.1.1 Overview of an Interrupt

Interrupts are delivered to the process in a packet format which looks like a 64 byte write on the UPA; this implies 4 cycles of 128 bits of data (or 8 cycles of 64 bits of data). However, only 3 double words are used to carry "pertinent" information. Note that U2P does not deliver interrupt data, only the Interrupt Number.

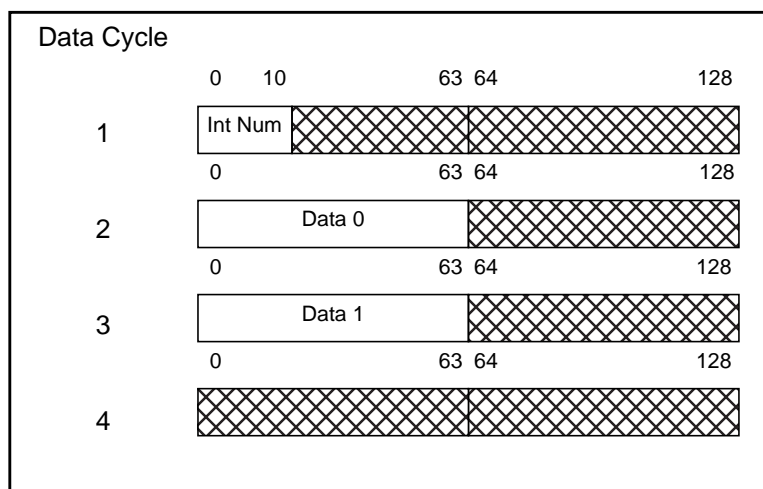

Figure 8-3 Mondo Vector Format on UPA Data Bus

The first data cycle contains the interrupt number (11 bits). The second and third data cycles contain 64 bits of data. These data fields may contain interrupt specific information such as address, timer values, error information, status register values, etc. Again note that U2P does not deliver Data 0 and Data 1. All other bits are not used (driven to 0 on the data bus).

As much as possible, the interrupt number is specific to each interrupt source, which allows software to uniquely identify the source of the interrupt without having to poll all interrupt sources, thus reducing overhead in processing interrupts.

Note that there is no priority associated with the interrupt packet. Thus, interrupts are processed on a first-come-first-serve basis.

Each CPU can process only one interrupt at a time. All subsequent interrupts that are delivered to a busy CPU will get Naked on the UPA. The interrupt source must then retry later.

8.2.1.2 Interrupt Number Register

Generally, each interrupt source has an Interrupt Number Register (INR) associated with it. The INR is either fully or partially software programmable and contains the Interrupt Number, which is delivered in the first data cycle, the MID of the processor the interrupt is to be sent, and a valid bit which enables or disables the interrupt.

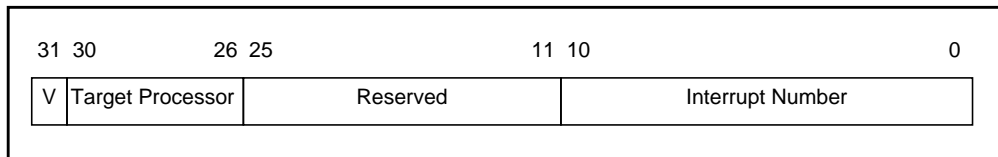

Figure 8-4 Full INR Contents

As shown the INR has 3 fields:

1. Valid bit (1 bit) - enables the interrupt when set to 1. Note that when an interrupt is present and the valid bit is 0, the interrupt is prevented from being delivered. However, once the valid bit is set to 1, the interrupt is delivered.
2. Target Processor (5 bits) - used to determine the address of the Interrupt in the UPA header. The Mondo Dispatch Unit also uses the LSB of the Target to determine which of two arbitration pools the interrupt will go into.
3. Interrupt Number (11 bits) - delivered in the first data cycle.

For most of the interrupts, the Interrupt Number field is broken further broken down into two separate fields: the Interrupt Group Number (IGN) and the Interrupt Number Offset (INO). The IGN is the same for all of these interrupts, and is set in U2P's main Control/Status register. The INO is a fixed value depending on the interrupt. So for these interrupts, the Interrupt Number in the INR is read-only. For two of the interrupts that U2P handles (graphics and UPA expansion), the Interrupt Number is fully programmable in the INR.

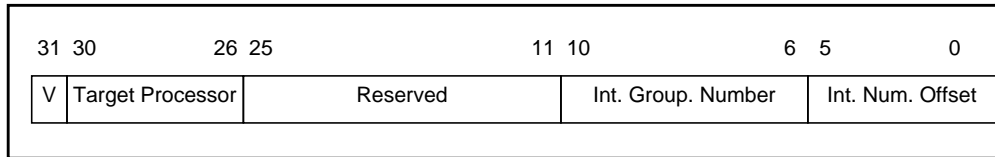

Figure 8-5 Partial INR Contents

8.2.2 Interrupt Types

Interrupts that U2P processes are classified by four characteristics:

1. Internal/External.
2. Level/Pulse.
3. Priority.
4. Synchronization with DMA.

8.2.2.1 Internal/External

Internal Interrupts

Internal Interrupts refer to those interrupts that are generated within U2P. Each internal interrupt source has a dedicated set of signals to the Mondo Unit for raising an interrupt. There are a total of 7 internal interrupts.

- ECC - The ECC unit will raise an interrupt when it detects a correctable or uncorrectable error for PIO Writes Requests or DMA Read Replies. There are 2 ECC interrupt lines, one for correctable and one for uncorrectable errors.
- Power Management - The Power Management interrupt is issued by U2P in order to wake up a system that is sleeping. It can be triggered by a wakeup request from a timer, or by wakeup requests from either PBM (due to DMA activity).
- PCI Bus Modules - Each PBM has an interrupt which will be asserted for error conditions on its associated PCI bus.
- Timer/Counters - Each Timer/Counter will raise an interrupt when its counter has reached its programmed limit. There are 2 Timer/Counter interrupts (1 for each Timer/Counter).

External Interrupts

External Interrupts refer to those interrupts that are generated external to U2P. All external sources for interrupts (PCI, OBIO, Graphics, and UPA) go through the Interrupt Concentrator. The Interrupt Concentrator logic resides external to U2P (e.g. in the RIC ASIC).

The Interrupt Concentrator samples all interrupts lines and in round-robin fashion, presents one of them at a time to U2P. The 38 interrupt lines are encoded into a 6 bit value to U2P. This was done to save pins on U2P.

- PCI - U2P supports 6 total PCI slots on two separate busses. Each PCI slot has 4 interrupt lines. So, there are 24 interrupt lines from PCI.
- OBIO (On-board IO Devices) - There are 12 interrupts from OBIO devices.
- Graphics/UPA - 2 UPA slot interrupts are supported. These are the only two interrupts that are of pulse type (see paragraph 8.2.2.2). These are also the only interrupts with the full INR register (fully software programmable). All other interrupts have a IGN and INO fields.

8.2.2.2 Level/Pulse

An interrupt can be either level or pulse driven. Level interrupts have three states associated with them: Idle, Received, and Pending, (see Figure 8-6). Level interrupts include all interrupts except for the Graphics and UPA interrupts.

Table 8-1 Level Interrupt States

State	Description
00	Idle - no interrupt has been received yet
01	Received - the source has raised an interrupt; the interrupt is going through decoding and arbitration
11	Pending - the interrupt has won arbitration; it will be or has been delivered; the interrupt is disabled until a process PIO writes the state register to set the interrupt back to IDLE
10	Reserved

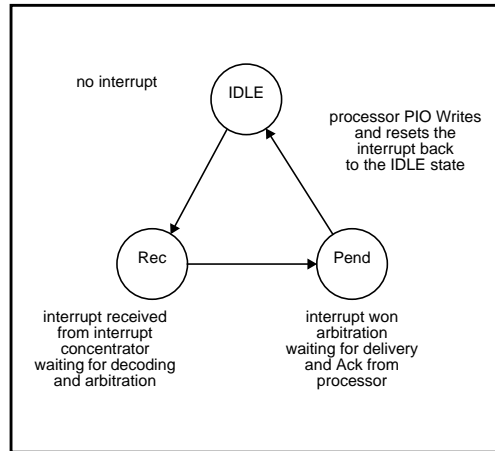

Figure 8-6 Level Interrupt States

Pulse Interrupts only have two states: Idle and Received. After the U2P delivers the interrupt, the interrupt returns to the Idle state. No software intervention is needed as in the Level interrupts case. Pulse interrupts include the Graphics and UPA Interrupts.

8.2.2.3 Priority

Each interrupt has a priority associated with it. There are a total of 8 priority levels (8 being the highest priority, 1 being the lowest).

Priority is taken into account during interrupt arbitration. When multiple interrupts are present, the highest priority interrupt is delivered first. If multiple interrupts with the same priority are present, the interrupts are delivered in a round-robin fashion. When all interrupts at the highest priority level are delivered, the next highest priority level is processed.

Table 8-2 Interrupt Receiver State Register

Level	Number of Interrupts	Source
8	6	Audio Record, Power Fail, Floppy, UE ECC, CE ECC, PBMA Error
7	6	Kbd/mouse/serial, Serial Int, PBMB Error, Audio Playback PCI_A0_INTA#, PCI_A1_INTA#

Table 8-2 Interrupt Receiver State Register (Continued)

Level	Number of Interrupts	Source
6	6	Timer 0, Timer 1 PCI_B0_INTA#, PCI_B1_INTA# PCI_B2_INTA#, PCI_B3_INTA#
5	6	OB Graphics, UPA64S Int PCI_A0_INTB#, PCI_A1_INTB# PCI_A0_INTC#, PCI_A1_INTC#
4	6	Keyboard Int, Mouse Int PCI_B0_INTB#, PCI_B1_INTB# PCI_B2_INTB#, PCI_B3_INTB#
3	6	SCSI Int, Ethernet Int PCI_B0_INTC#, PCI_B1_INTC# PCI_B2_INTC#, PCI_B3_INTC#
2	4	Parallel Port, Spare Int PCI_A0_INTD#, PCI_A1_INTD#
1	5	Power Management PCI_B0_INTD#, PCI_B1_INTD# PCI_B2_INTD#, PCI_B3_INTD#

8.2.2.4 Synchronization with DMA writes

When the end of a DMA write operation is signalled to software via an interrupt, U2P guarantees that all the DMA write data will actually be written to memory before the interrupt is seen. In order for this to happen, the MDU and PBM blocks communicate for any interrupt that is coming from a PCI source. Just before the MDU block dispatches any PCI interrupt request, it notifies the appropriate PBM block that an interrupt is pending. If there is any buffered DMA write data in the PBM, it will stall the MDU until that write data has been sent to the UPA block of U2P. New DMA write data that comes in while waiting for old data to flush will not cause additional stalling.

Onboard IO devices are considered to be PCI bus B sources.

8.2.3 Interrupt Table

Table 8-3 summarizes all of the interrupts that U2P handles. For each interrupt, the source, type, priority and any synchronization of the interrupt is listed. For external interrupts, the value of the INT_NUM bus from the external concentrator that will cause that interrupt is listed (this will not in general match the INO). Also included is the name of the pin on the RIC ASIC which will cause the correct INT_NUM to be

asserted. The RIC ASIC is the standard external concentrator found in UltraSPARC systems, and since it was originally designed for SBus based systems, there is the potential for some confusion when hooking it up in a system with U2P.

Table 8-3 Summary of Interrupts

Offset	Interrupt	Int/Ext	Source	Type	Priority	Synch To	INT_NUM	RIC pin
000000	PCI A Slot 0, INTA#	Ext	PCI	Level	7	PBMA	000111	SB0_INTREQ7
000001	PCI A Slot 0, INTB#	Ext	PCI	Level	5	PBMA	000101	SB0_INTREQ5
000010	PCI A Slot 0, INTC#	Ext	PCI	Level	5	PBMA	010101	SB2_INTREQ5
000011	PCI A Slot 0, INTD#	Ext	PCI	Level	2	PBMA	000010	SB0_INTREQ2
000100	PCI A Slot 1, INTA#	Ext	PCI	Level	7	PBMA	001111	SB1_INTREQ7
000101	PCI A Slot 1, INTB#	Ext	PCI	Level	5	PBMA	001101	SB1_INTREQ5
000110	PCI A Slot 1, INTC#	Ext	PCI	Level	5	PBMA	011101	SB3_INTREQ5
000111	PCI A Slot 1, INTD#	Ext	PCI	Level	2	PBMA	001010	SB1_INTREQ2
010000	PCI B Slot 0, INTA#	Ext	PCI	Level	6	PBMB	000110	SB0_INTREQ6
010001	PCI B Slot 0, INTB#	Ext	PCI	Level	4	PBMB	000100	SB0_INTREQ4
010010	PCI B Slot 0, INTC#	Ext	PCI	Level	3	PBMB	000011	SB0_INTREQ3
010011	PCI B Slot 0, INTD#	Ext	PCI	Level	1	PBMB	000001	SB0_INTREQ1
010100	PCI B Slot 1, INTA#	Ext	PCI	Level	6	PBMB	001110	SB1_INTREQ6
010101	PCI B Slot 1, INTB#	Ext	PCI	Level	4	PBMB	001100	SB1_INTREQ4
010110	PCI B Slot 1, INTC#	Ext	PCI	Level	3	PBMB	001011	SB1_INTREQ3
010111	PCI B Slot 1, INTD#	Ext	PCI	Level	1	PBMB	001001	SB1_INTREQ1
011000	PCI B Slot 2, INTA#	Ext	PCI	Level	6	PBMB	010110	SB2_INTREQ6
011001	PCI B Slot 2, INTB#	Ext	PCI	Level	4	PBMB	010100	SB2_INTREQ4
011010	PCI B Slot 2, INTC#	Ext	PCI	Level	3	PBMB	010011	SB2_INTREQ3
011011	PCI B Slot 2, INTD#	Ext	PCI	Level	1	PBMB	010001	SB2_INTREQ1
011100	PCI B Slot 3, INTA#	Ext	PCI	Level	6	PBMB	011110	SB3_INTREQ6
011101	PCI B Slot 3, INTB#	Ext	PCI	Level	4	PBMB	011100	SB3_INTREQ4
011110	PCI B Slot 3, INTC#	Ext	PCI	Level	3	PBMB	011011	SB3_INTREQ3
011111	PCI B Slot 3, INTD#	Ext	PCI	Level	1	PBMB	011001	SB3_INTREQ1
100000	SCSI	Ext	OBIO	Level	3	PBMB	100000	SCSI_INT
100001	Ethernet	Ext	OBIO	Level	3	PBMB	100001	ETHERNET_INT
100010	Parallel Port	Ext	OBIO	Level	2	PBMB	100010	PARALLEL_INT

Table 8-3 Summary of Interrupts (Continued)

Offset	Interrupt	Int/Ext	Source	Type	Priority	Synch To	INT_NUM	RIC pin
100011	Audio Record	Ext	OBIO	Level	8	PBMB	100100	AUDIO_INT
100100	Audio Playback	Ext	OBIO	Level	7	PBMB	011111	SB3_INTREQ7
100101	Power Fail	Ext	OBIO	Level	8	PBMB	100101	POWER_FAIL_INT
100110	Kbd/Mouse/Serial	Ext	OBIO	Level	7	PBMB	101000	KEYBOARD_INT
100111	Floppy	Ext	OBIO	Level	8	PBMB	101001	FLOPPY_INT
101000	Spare Hardware	Ext	OBIO	Level	2	PBMB	101010	SPARE_INT
101001	Keyboard	Ext	OBIO	Level	4	PBMB	101011	SKEY_INT
101010	Mouse	Ext	OBIO	Level	4	PBMB	101100	SMOU_INT
101011	Serial	Ext	OBIO	Level	7	PBMB	101101	SSER_INT
101100	Timer 0	Int	Timers	Level	6			
101101	Timer 1	Int	Timers	Level	6			
101110	Uncorrectable ECC	Int	ECC	Level	8			
101111	Correctable ECC	Int	ECC	Level	8			
110000	PCI Bus A Error	Int	PBMA	Level	8			
110001	PCI Bus B Error	Int	PBMB	Level	7			
110010	Power Management	Int	Timers, PBMA, PBMB	Level	1			
From INR	Graphics	Ext	UPA	Pulse	5		100011	GRAPHIC1_INT
From INR	UPA Expansion Slot	Ext	UPA	Pulse	5		100110	GRAPHIC2_INT
N/A	No interrupt	Ext	None	N/A	N/A		111111	

8.2.4 Processing an Interrupt

The Mondo Dispatch Unit in U2P is optimized for a two processor system. The Mondo Dispatch Unit is composed of 4 main blocks: Interrupt Receiver, Interrupt Decoder, Interrupt Arbiter, and the Interrupt Dispatcher. These blocks are described as follows.

8.2.4.1 Interrupt Receiver

The Interrupt Receiver receives all of the internal interrupt requests, as well as external interrupt numbers from the Interrupt Concentrator one at a time. It decodes the interrupt and stores it in a 2 bit state register. There is one state register for each interrupt source (45 total). The Graphics and UPA interrupts have a 1 bit state register, since they are Pulse Interrupts.

When an interrupt is in the received state, its interrupt line will be asserted to the next block, the Interrupt Decoder block.

8.2.4.2 Interrupt Decoder

The Interrupt Decoder uses the INR for each interrupt to determine the destination CPU for that interrupt. This is optimized for a systems of one or two CPUs, as only the least significant bit of the CPU's ID is used. The 45 interrupt lines from the Interrupt Receiver are fed into this block. The Mondo Unit keeps the INR of all interrupts, external and internal.

The output of the Interrupt Decoder is 2 sets of 45 interrupt lines (45 interrupt lines for each CPU). These are fed into the next block, the Interrupt Arbiter.

8.2.4.3 Interrupt Arbiter

The Interrupt Arbiter arbitrates among two sets of 45 interrupt lines and chooses a winner. The first stage of arbitration involves choosing one winner for each CPU. The highest priority level interrupts are chosen first. Then a round-robin among those interrupts picks the winner.

After a winner has been chosen for each CPU, a round-robin chooses between the two CPUs for a winner. This is fed into the next block, the Interrupt Dispatcher.

8.2.4.4 Interrupt Dispatcher

The Interrupt Dispatcher is composed of the following three sub-blocks.

Packet Builder FSM

The Packet Builder takes the winner from the Interrupt Arbiter and assembles the interrupt packet in the appropriate CPU's Packet Buffer. There is one Packet Buffer for each CPU. Once the Packet Buffer contains an interrupt, it prevents that CPU from winning arbitration until the buffer is cleared (i.e. - the interrupt delivered and Acked).

Dispatcher FSM

The Dispatcher checks each Packet Buffer in a round-robin fashion. If the Packet Buffer contains a valid interrupt that is ready to be sent, the Dispatcher will raise a request to the U2P Bus Controller to deliver an interrupt packet (which looks like a 64 byte write) to the UPA interface.

After delivering the interrupt, the Dispatcher waits for the Ack or Nack from the System Controller. If the interrupt is Acked, the Packet Buffer is cleared. If the interrupt is Nacked, the Dispatcher clears the Retry Bit in the Packet Buffer. In both cases, the Dispatch proceeds to the next Packet Buffer.

Note that this means that the Mondo Unit dispatches only one interrupt at a time, and waits for the Ack or Nack before dispatching the next interrupt.

Retry FSM

There is a Retry FSM associated with each Packet Buffer. When the Retry Bit is cleared (by the Dispatcher), the Retry FSM waits for a common free-running counter to roll over twice then sets the Retry Bit.

Setting the Retry Bit sets the Packet Buffer into the ready state for when the Dispatcher comes around the next time.

U2P Timer/Counter

9.1 Overview

There are two independent but identical timers in U2P. Each provides either periodic interrupts or alarm-clock (callout) interrupts to a selected processor.

The features supported:

- Limit Register - to set the interrupt enable, reload, periodic bits, and the counter interrupt comparison value.
- Count Register - for loading the counter on write and for returning the current count on read.
- Periodic interrupts can be generated.
- Interrupt can be disabled.
- 29-bit counter which allows a maximum count of 0x1FFFFFFF or 536 seconds using a 1 microsecond count interval.

9.2 Timer Functional Description

It is expected that the two timers will have independent functions; one used for system callout events, and the other for operating system profiling. It is up to the processor to issue cross-calls to other processors if broadcast is needed. Each timer has separate Count and Limit registers. In order for the processor to uniquely identify the source of the timer interrupts, each timer will also have its own Interrupt Number Register.

The two timers operate as follows:

- Writes to the Limit Register set the LIMIT value, and cause the corresponding timer to reset to zero if (RELOAD == 1).
If (RELOAD == 0), then the LIMIT gets set without affecting the value of COUNT.
- When (COUNT == LIMIT) and (INT_EN == 1), an interrupt request is made. When granted, the Mondo Vector with the corresponding INR is dispatched.
- If (PERIODIC == 1), whenever (COUNT == LIMIT) then the counter is reset to zero and continues counting.

Else if (PERIODIC == 0), when (COUNT == LIMIT) then the counter continues to count normally without taking an intermediate reset. Note that the counter will still wrap-around to zero if the current count has reached 0xFFFFFFFF.

- To obtain a periodic interrupt every 'N' microseconds, the LIMIT should be set to 'N-1'.

Note – If (INT_EN == 0), when (COUNT == LIMIT) then the counter will not send interrupt. However, counter might be reset depending on the state of PERIODIC.

Little-Endian Support

On one side of U2P, the UPA bus is big-endian. On the other side, each PCI bus is little-endian. U2P provides the necessary support to connect the two together. The main feature is called “byte twisting”: from a hardware perspective, the bytes on the datapath from a PCI bus are twisted around before connecting to any other datapath within U2P, so that bits 63:56 map to bits 7:0, bits 55:48 map to bits 15:8, etc. From another perspective, this ensures that logical byte lanes are connected: the byte at address 0 on the big-endian side is directly wired to the byte at address 0 on the little-endian side. As a result, all byte-sized PIOs and byte-stream DMA is handled correctly. This, along with other features built into SPARC V9 processors, allows all PIO and DMA activity to/from the PCI bus to take place correctly.

10.1 Big-and Little-endian regions

10.1.1 Address Space

U2P’s 8Gb UPA address space consists of several regions. The lower 16Mb, from 0x0.0000.0000-0x0.0100.0000 allows access to internal registers within U2P. This portion of the address space is big-endian. There is no byte twisting done for accesses within this range.

There is a large region of unused/reserved address space from 0x0.0202.0000-0x0.ffff.ffff. Reads to this address range cause an error response (P_RERR), and writes are simply ignored, so there is nothing on which to perform byte twisting.

The remaining address regions are little-endian. The upper 4Gb, from 0x1.0000.0000-0x1.ffff.ffff is used for accesses to PCI bus memory space. The 16Mb region from 0x0.0100.0000-0x0.01ff.ffff is used for access to PCI configuration space, and there are

two 64Kb regions from 0x0.0200.0000-0x0.0201.ffff that are used to access PCI bus I/O space. All of these address ranges are little-endian, and all accesses to them use byte twisting.

If U2P provides the path to the system PROM, the PROM is found at offsets 0x1.f000.0000-0x1.f0ff.ffff within U2P's UPA port. This falls in the upper 4Gb region, which U2P considers little-endian, and does byte-twisting. In spite of the byte-twisting, and because of the way the PROM is programmed, the PROM appears to the system correctly as a big-endian device. This is explained in more detail below.

10.1.2 Internal blocks

Most of U2P's internal blocks are big-endian: the 64-bit data paths within these blocks are connected to the UPA's 64-bit data bus with no byte twisting. The only exceptions are the two PBM blocks. Since these blocks control the little-endian PCI busses, they are considered little-endian. For each data interface from a PBM block to the rest of U2P (in addition to interfacing to the main internal busses, each PBM has a data interface with a streaming cache block), byte twisting is in effect.

Note – Each PBM contains some registers mapped into the lower 16Mb of U2P's UPA port, which is a big-endian address region. So that these registers are not affected by the byte twisting of the PBM's data paths to the rest of the chip, within the PBM, the data path to these registers is “retwisted”.

10.2 Byte Twisting

Figure 10-1 diagrams what is meant by byte twisting. It shows how data is manipulated from a 32-bit little-endian PCI bus to a 64-bit big-endian UPA bus. The case of a 64-bit PCI bus is a straightforward modification of this diagram, and won't be shown.

For each bus, a typical connection to memory is shown, along with the byte addresses of the memory. This is mainly for reference - it is one way of showing exactly what is meant by big- or little-endian. It helps to show that the “logical” byte lanes of each bus are correctly connected thru U2P.

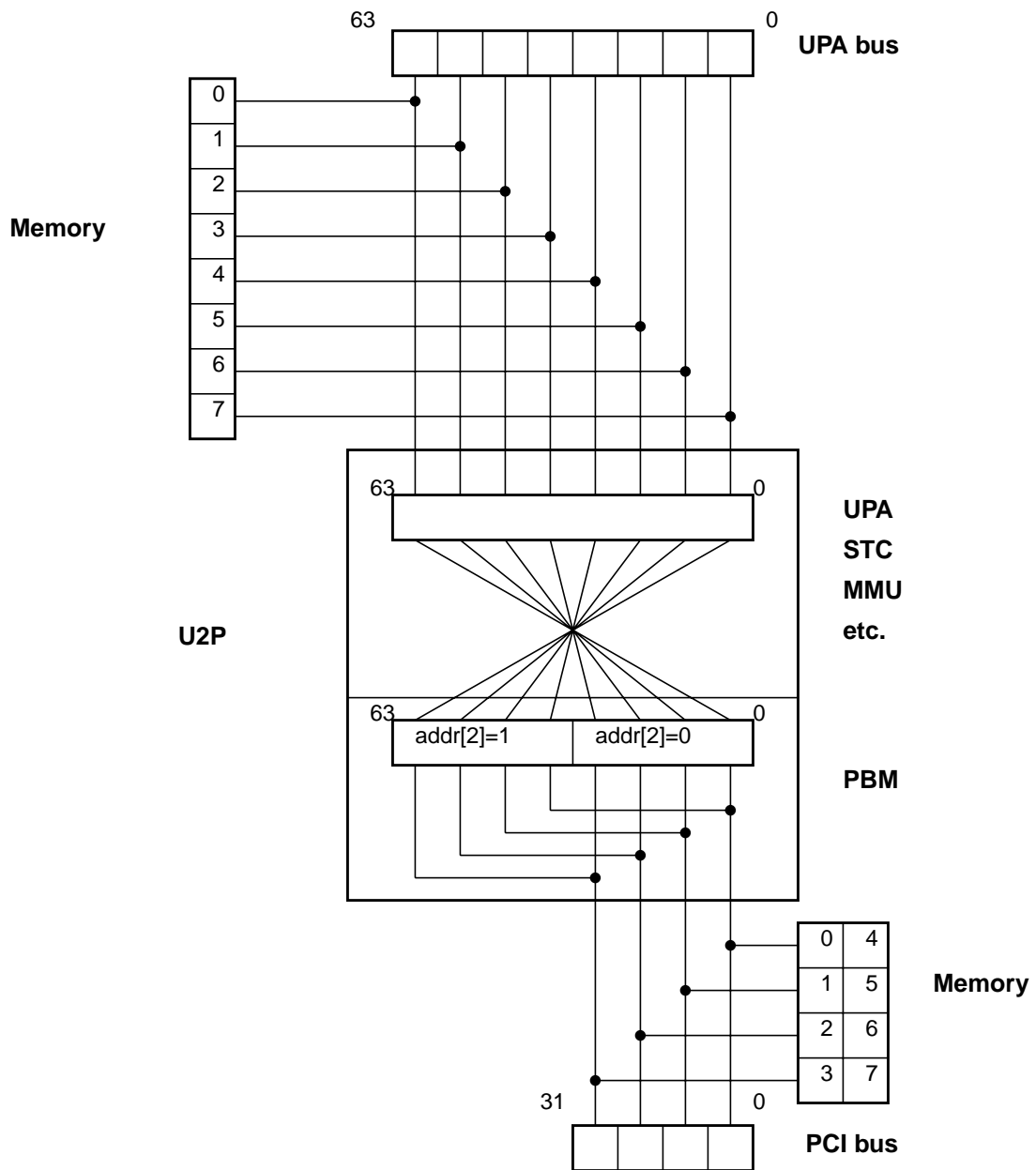

Figure 10-1 U2P Byte Twisting

10.3 Specific Cases

The following sections detail specific types of data transfers, and how correct byte ordering is maintained in each case.

10.3.1 PIOs

Normal

Due to the byte twisting, all byte sized PIOs work correctly. The byte lane used for a given address on the big-endian side is directly wired to the byte lane used for that address on the little-endian side.

For any access larger than a byte, byte-twisting is not sufficient. For example, if the 32-bit value 0x12345678 is written to a 32-bit register on a PCI device, the PCI device will see the value 0x78563412 instead.

To correct for this, SPARC V9 CPUs have special support for little-endian access. By either marking the page containing the PCI register as little-endian in the processor's MMU, or by using one of the little-endian Address Space Identifiers (ASIs), the CPU will alter its ordering of the bytes so that the PCI device correctly sees 0x12345678.

PROM accesses

Instruction fetches from the PROM are a special case because they are unable to use the little-endian features of SPARC V9 processors. PROM instruction fetches, like all instruction fetches, are always done in big-endian mode.

The PROM is a byte device on the EBus2, controlled by PCIO. PCIO allows 32-bit access to the PROM, and stacks the bytes in little-endian format, such that the byte at address 0 in the PROM appears on PCI bus data bits 7:0, byte 1 is on bits 15:8, etc. To function correctly with the byte-twisting of U2P, and lack of other byte re-ordering by the processor, the PROM needs to be programmed in big-endian order - byte 0 in the PROM should be the MSB of the first instruction.

If this is done, PROM instruction fetches will have the correct byte ordering.

Because of this required byte programming ordering for the PROM, data accesses to the PROM should not use the little-endian byte re-ordering of the processor, even though the PROM is located within the little-endian PCI space. If only big-endian accesses are made to the PROM, PIOs of any size return data with the correct byte order.

10.3.2 DMA

Data streams

Because byte lanes at the same address are connected, DMA of byte streams works correctly without any further intervention. A PCI device that receives the byte stream (01,02,03,04) would pack the bytes into a 32-bit register starting with the LSB of the register, i.e. 0x04030201. After transferring to memory on the PCI bus, the value 0x01 would be at the lowest memory location, as desired.

After byte twisting, the value that appears on the UPA bus would be 0x01020304. Since the MSB on the UPA bus is the lowest memory location, the value 0x01 is still stored at the lowest memory location, as desired.

Descriptors

This case is similar to PIOs of size greater than one byte. With just byte twisting, a DMA descriptor access would get the wrong byte ordering. For example, if the value 0x12345678 were set up in an address field in a descriptor, a PCI device using DMA to fetch the descriptor would see the value as 0x78563412 instead.

To avoid this, the little-endian features of the processor are used again. Processor loads and stores to the descriptors should be specified as little-endian. This will re-order the bytes in memory when the descriptor is built so that after byte twisting, the PCI device sees the correct value.

Error Handling

11.1 Overview

This chapter describes the error detection, correction, and error reporting mechanisms supported by U2P.

Errors detected in the system are classified as either fatal errors or non-fatal hardware errors. A fatal error may result in a system reset if the error reset is enabled by software. Actions taken on non-fatal hardware errors include generating interrupts, setting status register bits, or no action at all.

11.1.1 Fatal Hardware Errors

The only type of fatal error detectable by U2P is UPA address parity error.

11.1.1.1 UPA Address Parity Error

The UPA address bus carries address and control information for UPA transactions. The format of the address packet is described in the UPA Interconnect Architecture document. U2P supports parity generation/checking on its UPA address bus. The parity bit is driven by a master UPA port at the same time the address packet is driven onto the bus.

Address parity error is taken as a fatal error to the system. Any UPA device including U2P can detect address parity errors. The action taken on an address parity error is as follows:

- The device detecting address parity error sends a P_FERR reply to the system controller (SC) if it is enabled to do so. The SC will generate reset to the system if the EN_FATAL bit is set in the SC Control Register. The SC will log the fatal error condition in the SC Port Status Register and SC Control Register.

11.1.2 Non-fatal Hardware Error

11.1.2.1 UPA Datapath Uncorrectable Error

U2P connects to a 64 bit wide UPA data bus, with 8 bits of ECC, and does support generation and checking of ECC syndrome and automatic correction of correctable errors on all UPA transactions.

Two types of ECC errors are checked by UPA ports like U2P: Correctable Errors (CE) and Uncorrectable Errors (UE). CE's and UE's can come from the following sources:

- Corruption on the UPA or memory datapaths.
- A faulty device, such as DRAM, XB1, or a UPA device.

In addition to these normal error sources, there are other cases where a device can force a UE to the system. U2P will translate parity errors on PCI transactions into forced UE errors on the UPA. Information related to a U2P generated UE is logged in the U2P PCI Control/Status Register.

If U2P detects a CE, data is corrected before it is used. Data transfer continues as if there was no error. U2P will log and report the error if enabled. Upon a UE, U2P will also log and report the error if enabled. In addition, the error will be carried along with the data, showing up on the PCI bus as a Target Abort, to make sure the erroneous data is not consumed. PIO writes to U2P with UE errors are aborted.

U2P detects and corrects ECC errors on the data it receives. The checking and correction are done on the following operations:

- PIO writes to U2P and devices controlled by U2P.
- PCI DVMA reads from memory and UPA devices.
- PCI DVMA partial line writes to memory.

U2P reports ECC errors to the processor via interrupt as long as ECC checking and ECC interrupt are both enabled. Error information is logged in the UE or CE AFSR/AFAR. For more information about the ECC control register and UE/CE asynchronous error registers please refer to Chapter 13, Programmers Model.

11.1.2.2 UPA Timeout

A UPA timeout can be generated by U2P in response to a PIO read to a non-existing PCI location or non-responsive PCI device. A UPA timeout can be received by U2P for any non-cacheable read transactions it generates.

PIO writes to U2P and non-cacheable write transactions generated by U2P cannot result in timeout responses.

11.1.2.3 UPA Read Error

Other than address parity errors the UPA does not provide for error replies to write transactions. A UPA device can only send error replies to read transactions. Errors detected by a UPA slave port should be reported through an interrupt. A UPA slave can send a UPA read error reply for various reasons. For example U2P will respond with a read error reply if a connected PCI target device issues a target-abort to it.

11.1.2.4 PCI Data Parity Error

PCI mandates that all devices generate parity for the address/data and cmd/byte enable busses. For 32-bit transfers, a single bit parity is provided for the 32 bits of address/data and 4-bit cmd/byte enable bus. For 64-bit data transfers, an additional parity bit covers the high 32 bits of address/data and the high 4 lines of the cmd/byte enable bus. PCI implements even parity.

This section covers only parity errors on data phases, address parity errors are covered in section 11.1.2.9.

U2P's parity checking and generation are always enabled. Error reporting may be disabled via the PER bit in the Configuration space Command register. Setting PER enables U2P to report PIO data parity errors to the processor and DVMA data parity errors to the bus master. When a data parity error is detected or signalled U2P does not terminate the transaction prematurely but attempts to take it to completion.

If PER is enabled, a parity error detected on PIO read will be reported by providing data on the UPA bus with an intentional UE-ECC error, and by setting the DPE and DPD bits in the Configuration space Status register. U2P also asserts the PCI signal 'PERR#' to indicate to the target that it received bad parity. A parity error signalled via PERR# on a PIO write will be logged as an asynchronous error. DPE, and DPD will be set, the AFSR P_PERR/S_PERR bits will be set, AFAR will be loaded with the PIO address, and a PCI interrupt will be generated.

If PER is enabled, a parity error detected during a DVMA write will be reported by asserting PERR# to the bus master and by setting the DPE Status bit. Subsequent action taken by the master is device dependent. If the DVMA write is targeted for a

UPA device or memory, U2P will provide data with a UE-ECC. A parity error signalled via PERR# on a DVMA read will be reported by setting the DPE Status bit. Subsequent action taken by the bus master is device dependent.

Note that for the PIO and DVMA cases above, if PER is disabled only the DPE Status bit is set - no other error reporting action is taken and data is transferred as if there had been no error.

11.1.2.5 PCI Target-Abort

If an error occurs during an access to a PCI device, the device may terminate the transaction with a target-abort. Examples are unsupported byte enables, an unsupported addressing mode, an address parity error, and device specific errors. Any data that may have been transferred during the transaction before the target-abort occurred is corrupt and must not be used by the recipient.

A PIO read terminated with a target-abort results in an P_RERR reply being sent to SC with the RTA bit in U2P's Status register set. A PIO write which is terminated with a target-abort results in an asynchronous error. The P_TA/S_TA bit is set in the U2P AFSR and the physical address loaded into the AFAR. The RTA Status bit is also set for writes.

U2P will issue a target-abort in the following cases: taking an IOMMU address translation error, and receiving a UE ECC error on data from the UPA bus. U2P sets the STA Status bit, but in all cases it is up to the bus master to report the error to the system.

11.1.2.6 PCI Timeout

U2P will return a UPA Timeout Reply (P_RTO) under a variety of PIO read error cases. If no device is mapped (or responds) to the PCI address the transaction is terminated with a master-abort and the U2P RMA Status bit is set. If a device terminates a PIO read with too many retries (disconnect with no data transfer) U2P will stop retrying the access and issue a P_RTO. U2P's Retry Limit is set to 16,384 successive retries.

PCI has no timeout mechanism once a transaction has been claimed (via DEVSEL_) if the target never terminates. However, the PCI specification does recommend that all targets issue a retry when more than 16 PCI clocks will be consumed waiting for the first data transfer. When a device claims the transaction but never signals that it is ready to transfer data, U2P will hang. This will only happen because of a device hardware error and is equivalent to a UPA device hardware error which could also hang the system.

11.1.2.7 DVMA ECC Error

The UPA UE-AFSR/AFAR registers and the PCI AFSR/AFAR registers log DVMA errors. Errors are logged in the following manner:

1. If UE interrupts are enabled, an interrupt will be posted when U2P detects a UE.
2. Data will be ignored by the Streaming Buffer when a UE occurs on a prefetch, and the buffer entry will be marked invalid.
3. A UE on a read from a streamable page will cause a target-abort to the PCI master device when any data from that cacheline is requested, even if the UE does not happen on the particular 8 byte quantity requested.
4. A UE on a DVMA read from a consistent page will cause a target-abort to the PCI master device only if the UE happens on the 8 bytes of data requested. Error free bytes will be transferred without error.
5. A UE on a DVMA partial write: if the DVMA transaction totally overwrites the 8 bytes with UE, no error will be reported. Good data and check bits will be provided for the data when writing it back to memory. If a DVMA transaction does not overwrite, or only partially overwrites, the UE data, U2P will force a UE-ECC to memory.

11.1.2.8 IOMMU Translation Error

The IOMMU translates the PCI DVMA address to a physical page address. The IOMMU also checks for access violations. Errors that can be detected by the IOMMU are out of range access, access to a invalid page and access with protection violation. An out of range access is a transaction that targets what is normally DMA space, but which is outside the currently programmed TSB table size. An invalid error happens when the DVMA page address does not have a valid physical page mapped to it. A protection error happens when the PCI master tries to write to a page that is marked as read-only. All of these errors will be reported with a target-abort to the device. The actual reporting of translation errors from the device to the system is device dependent.

11.1.2.9 PCI Address Parity Error

PCI Address parity errors may be reported during PIO operations and detected or reported during DVMA transfers. PCI's mechanism for reporting address parity errors is the "System Error". Address parity error reporting can be disabled (along with all parity error reporting) via the PER Command register bit.

When a DVMA address parity error is detected by U2P, it decodes and completes the transaction as normal, sets the SSE and DPE bits in the Status register, sets the PCI_SERR bit in the PCI CSR, and generates a PCI interrupt. U2P does not indicate a system error on the bus, however, any number of devices may simultaneously check address parity and generate a system error.

When a PIO address parity error is reported by a device via a system error, U2P will report the system error as described in section 11.1.2.10. Upon detecting the address parity error the target device has the option of:

1. Not claiming the transaction, thus generating a UPA timeout.
2. Issuing a target-abort, resulting in an P_RERR reply for reads and an asynchronous error for writes.
3. Completing the cycle as if there were no error and either generating a system error or an interrupt at some later time.

11.1.2.10 PCI System Error

The PCI System Error may occur on address parity errors as well as device specific fatal errors. System Error reporting can be disabled by the SERR_EN Command register bit.

Any PCI device may generate a system error at any time but only U2P is capable of detecting and reporting it to system software. When a system error is detected U2P generates a PCI interrupt and sets the PCI_SERR bit in the PCI CSR. The device(s) that generated the system error is required to set it's SSE Status register bit. Multiple system errors generated before the system software clears the PCI CSR will not cause additional interrupts, so it is important that software check all device Status registers.

11.1.3 Summary of Error Reporting

Table 11-1 summarizes the reporting of fatal errors detected by U2P.

Table 11-1 Summary of Fatal Error Reporting

Error Type	Type of operation	System Action	Error Register
UPA Address Parity Error	All	Reset	U2P Control/Status Register (APERR bit)

Table 11-2 summarizes non-fatal error detection/reporting in U2P. Some U2P register abbreviations are: CSR for the PCI Control/Status Register, UE, CE, PCI-AFRs for the various AFSR/AFARs, and Status for the PBM's Configuration space Status register.

Table 11-2 Summary of Non-Fatal Error Reporting

Transaction	Error Type	UPA Response	Error Register(s)	PCI Bus
PIO Read	Data parity	Force bad ECC	CSR, Status	Complete Transaction
	Master-abort	P_RTO	Status	Master-abort
	Target-abort	P_RERR	Status	Target-abort
	Retry Limit	P_RTO	Status	Cease Retries
	Timeout ¹	-	-	Hang
PIO Write	UE-ECC	UE Interrupt	UE-AFRs	No Transaction
	CE-ECC	CE Interrupt	CE-AFRs	Complete Transaction
	Master-abort	PCI Interrupt	PCI-AFRs, Status	Master-abort
	Target-abort	PCI Interrupt	PCI-AFRs, Status	Target-abort
	Retry Limit	PCI Interrupt	PCI-AFRs	Cease Retries
	Data Parity	PCI Interrupt	PCI-AFRs, Status	Complete Transaction
	Timeout ¹	-	-	Hang
Any PIO	Address Parity Error	-	-	Device dependent ²
Special Cycle	No Error	-	-	Master-abort
	Data parity	-	-	Device dependent ²

Table 11-2 Summary of Non-Fatal Error Reporting (Continued)

Transaction	Error Type	UPA Response	Error Register(s)	PCI Bus
DMA Read	UE-ECC	UE Interrupt	UE-AFRs, Status	Target-abort
	CE-ECC	CE Interrupt	CE-AFRs	Complete Transaction
	Data Parity	-	Status	Complete Transaction ³
	Prefetch ECC Error ⁴	UE Interrupt	UE-AFRs	Target-abort
DMA Write	UE-ECC ⁵	UE Interrupt	UE-AFRs	Complete Transaction
	CE-ECC ⁵	CE Interrupt	CE-AFRs	Complete Transaction
	Data Parity	Force bad ECC	CSR, Status	Assert PERR#, complete transaction ³
Any DMA	Address Parity	PCI Interrupt	Status	Complete transaction
	Translation Error	-	Status	Target-abort
PCI System Error	PCI System Error	PCI Interrupt	CSR, Status	SERR# sampled active

1. The target device claims the transaction but is never ready to transfer data.
2. A system error will likely be generated.
3. Master device should report error.
4. Error taken only if bad cacheline accessed
5. Sub-line writes only.

11.2 Unreported Errors

Certain error conditions are not reported by the U2P. Examples of these errors are listed below. Please beware that this list may not enumerate all unreported errors.

- A non-cacheable write from U2P to a non-existing or disconnected UPA port.
- A write to a read-only register in U2P is ignored.
- A non-cacheable write transaction from U2P that is directed to cacheable address space.
- A read from a write-only register in U2P returns unknown data, but no error.
- A UPA bus error or timeout during a DVMA write is ignored.
- Sending an interrupt to a non-existing or disconnected UPA port.

JTAG

12.1 Introduction

This chapter documents describes the features of the JTAG Test Access Port (TAP) for U2P. The JTAG macro which implements the IEEE 1149.1-1990 provides access to the test structures on the chip.

The TAP includes the TAP controller state machine, a instruction register, a bypass register, a device identification register and the necessary decoding logic. The TAP requires five dedicated pads: test data input (TDI), test data output (TDO), test mode select(TMS), test clock (TCK) and test reset (TRST).

12.2 TAP Controller

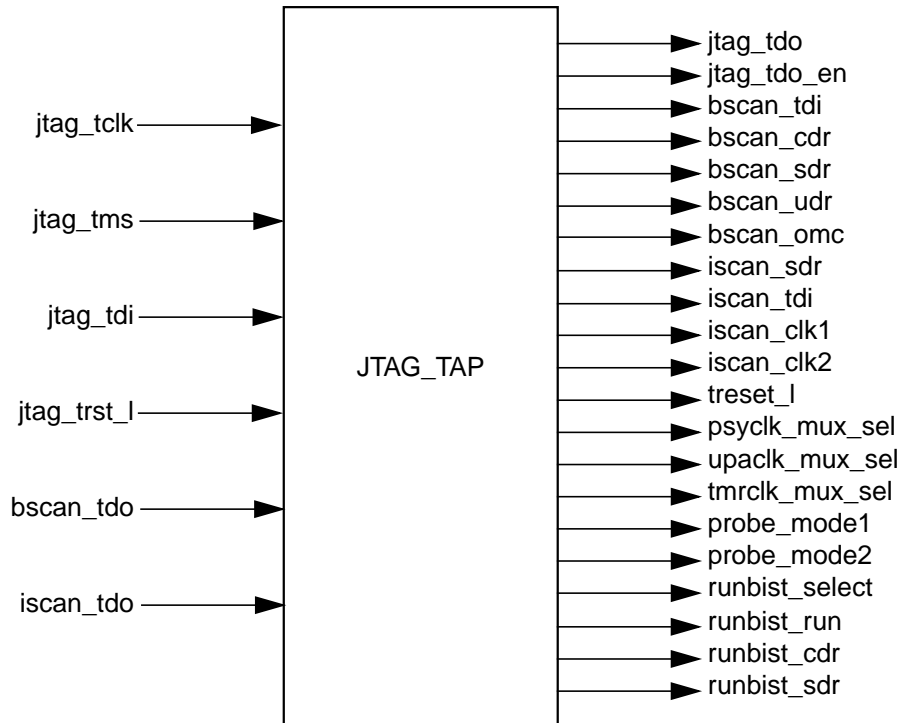

Figure 12-1 TAP Controller Block Diagram

The U2P JTAG TAP Controller is based around a standard IEEE 1149.1-1990 TAP controller. The TAP controller is a synchronous finite state machine which transitions on values of TMS (jtag_tms) and TCK (jtag_tclk). The TDI (jtag_tdi) and TDO (jtag_tdo) ports can be used to serially load one of several test modes as well as read and write data to the chip internals.

In addition to the required instructions used to manipulate the standard bypass and boundary scan registers, the JTAG controller has several additional instructions to control the internal scan register, two clock control registers as well as run several different test modes. (See *Section 12.2.2 Instruction Register* and *Section 12.4 Special JTAG Instructions*)

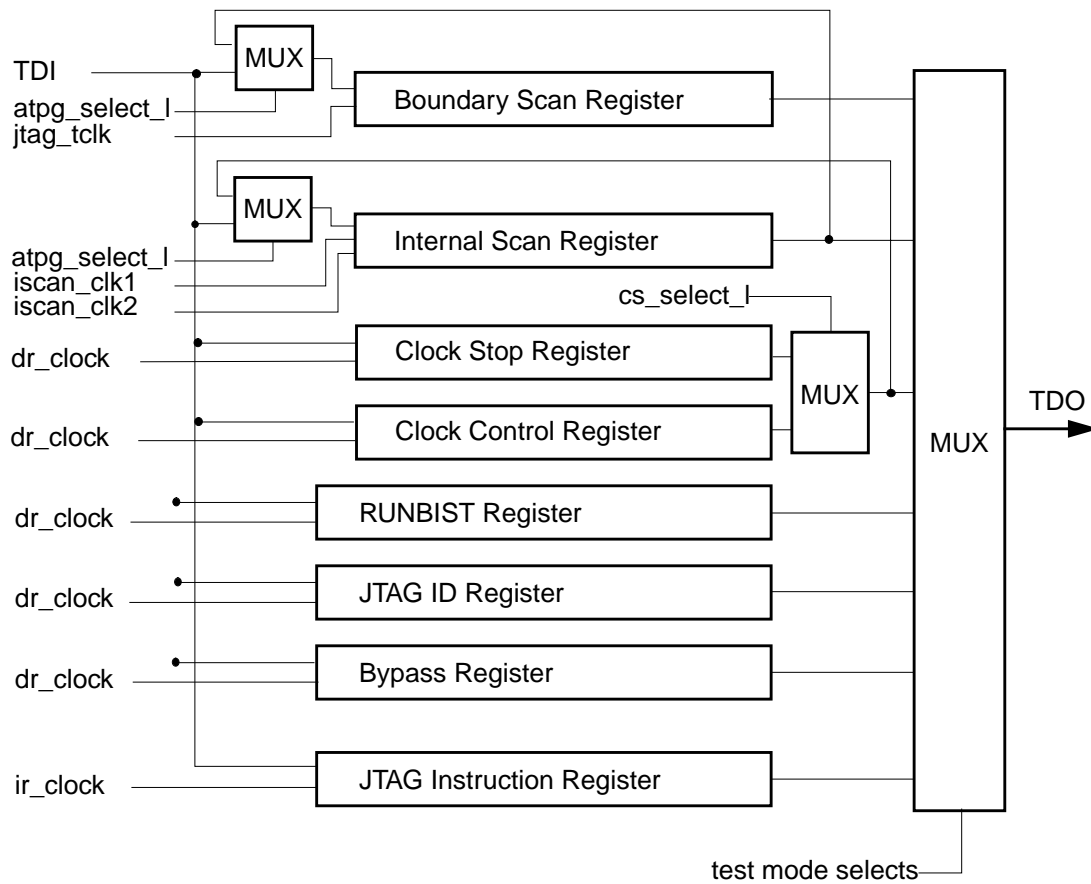

Figure 12-2 U2P Data registers

Descriptions of the I/O signals of the JTAG module can be found in Table 12-2.

Table 12-1 Description of signals in JTAG macro

Signal	Description
jtag_tclk	JTAG clock from chip pads
jtag_tdi	JTAG test data in from chip pads
jtag_tdo	JTAG test data out to chip pads
jtag_tms	JTAG mode select from chip pads
jtag_trst_l	JTAG test reset from chip pads

Table 12-1 Description of signals in JTAG macro (Continued)

Signal	Description
jtag_tdo_en	JTAG test data out enable to chip pads
bscan_tdi	Boundary scan data input (to bscan cells)
bscan_tdo	Boundary scan test data output
bscan_omc	Boundary scan output mode control
bscan_cdr	Boundary scan capture data register
bscan_sdr	Boundary scan shift data register
bscan_udr	Boundary scan update data register
iscan_sdr	Internal scan mode shift enable signal
iscan_clk1	Internal scan capture clock (domain 1)
iscan_clk2	Internal scan capture clock (domain 2)
iscan_tdi	Internal scan data input
iscan_tdo	Internal scan test data output
treset_l	Boundary scan output enable reset (buffered trst_l)
psyclk_mux_sel	Internal Scan mode select w/clock stop
upaclk_mux_sel	Internal Scan mode select w/clock stop
tmrclk_mux_sel	Internal Scan mode select w/clock stop
probe_mode1	probe_mode enable signal
probe_mode2	probe_mode enable signal
runbist_select	enable BIST logic
runbist_run	run BIST test(s)
runbist_cdr	RUNBIST capture data register
runbist_sdr	RUNBIST shift data register

The blocks which make up the U2P TAP controller can be found in Table 12-3.

Table 12-2 Components of the U2P TAP controller

Synchronous FSM and Decode logic
Instruction register
Instruction decode logic
Bypass register

Table 12-2 Components of the U2P TAP controller (Continued)

Internal register clocking logic
JTAG ID register
JTAG Boundary scan control logic
Clock Control Register
Clock Stop Logic
TDO mux logic

The following sections describe each of these blocks.

12.2.1 Synchronous FSM and Decode

The TAP controller is made up of two modules: a 4-bit, 16 state finite state machine and a block of state decode logic. Transitions between states occur synchronously at the rising edge of `jtag_tclk` in response to the `jtag_tms` signal or when `jtag_trst_l` goes low.

12.2.2 Instruction Register

The instruction register is used to select the test to be performed and/or the test data register to be accessed. The U2P instruction register is 4-bit wide shift register with parallel load and parallel outputs. At the start of an instruction register shift cycle (during the CAPTURE-IR state) the least two significant bits are loaded with '01' pattern. During the TEST-LOGIC-RESET controller state the instruction register is loaded with the IDCODE. The instruction register is right shifted by one bit at each rising edge of `jtag_tclk` when the state machine is in Shift-IR and is updated at the falling edge of the `jtag_tclk` in Update-IR.

The instructions found in Table 12-4 are supported in U2P.

Table 12-3 Instructions supported by U2P JTAG controller

Value	Instruction	Scan Chain	OMC	BCAP	ICAP
0000	extest	boundary	1	1	0
0001	sample	boundary	0	1	0
0010	intscan	internal	0	0	1
0011	atpg	atpg	1	1	1

Table 12-3 Instructions supported by U2P JTAG controller (Continued)

Value	Instruction	Scan Chain	OMC	BCAP	ICAP
0100	debug	internal	1	0	0
0101	delay	internal	0	0	1
0110	clamp	bypass	1	0	0
0111	intest	boundary	0	1	0
1000	int_omc	internal	1	0	1
1001	sel_ccr	ccr	0	0	0
1010	probe1	bypass	0	0	0
1011	probe2	bypass	0	0	0
1100	sel_cs	cs	0	0	0
1101	runbist	runbist	0	0	0
1110	idcode	id	0	0	0
1111	bypass	bypass	0	0	0

OMC defines the value of the output Mode Control for the boundary scan chain. Where OMC=1, the boundary cell output is driven by the internal update register; where OMC=0, the boundary cell output is driven from the core logic for output cells and from the pin for input cells.

BCAP indicates that a capture clock is generated for the boundary scan chain during the capture-DR state. Similarly, ICAP indicates that a capture clock is generated for the internal scan chain.

12.2.3 Instruction Decode Logic

The instruction decode logic decodes the value at the parallel outputs of the instruction register and selects the appropriate scan data register and control signals.

12.2.4 Bypass Register

The Bypass register provides a minimum length path between the test data input and the test data output. It consists of a single shift-register stage that loads a constant 0 in the Capture-DR TAP controller state when the mandatory BYPASS instruction is selected.

12.2.5 Internal Register Clocking Logic

This module generates the scan clocks for the internal scan flops (iscan_clk1 and iscan_clk2) and the scan enable to enable serial shifting of the internal scan chain. Clocks are generated during Capture-DR and Shift-DR for parallel captures and serial shifting, respectively.

12.2.6 JTAG ID Register

This is a 32 bit shift register which has four fields. The least significant bit is a one, the next 11 bits [11:1] are the Manufacturer ID, the next 16 bits [27:12] are the chip ID, and the most significant 4 bits [31:28] are the chip version. For version 3.1, the fields are as follows:

Version	4'b0100
Manufacturer ID	11'b00000011101
Chip ID	16'b0001100101010100

Thus the JTAG id for U2P is 3195403b hex.

12.2.7 Boundary Scan Control Logic

This block generates the boundary scan capture, shift and update signals which forms part of the boundary scan control bus that runs along the boundary scan chain. This control bus feeds the boundary scan cells.

12.2.8 BIST Control Logic

This block generates the BIST control signals to run the BIST tests, performs a capture of the BIST test results (BIST Flags) and allows the BIST test results to be shifted out. This control bus feeds the BIST control block in the core logic. runbist_run is asserted when the TAP controller enters the Run/Test-Idle state and indicates to the BIST controller that the BIST test should be run. Upon entering Capture-DR, runbist_cdr is asserts in order to capture the BIST test results into the scan register. runbist_sdr is asserted during Shift-DR to enable the scan register to be serial shifted. The result registers (made up on the BIST flags and the BIST control state) are connected between TDI and TDO for the entire time that the instruction is selected.

12.2.9 Clock Control Registers

This module actually contains two functional blocks: a Clock Stop register and a Clock Control register. The Clock Stop register is a 2-bit register used to initialize the clock stop logic in the TAP controller. Bit [0] enables the clocks to be stopped upon receiving an External Event signal (a rising edge from the pin, EXT_EVENT), which then allows the CLOCK_STOP logic to mux out the system clocks. Bit [1] forces a clock stop event by sending a clock_stop_force signal to the CLOCK_STOP logic. The signals clock_stop_en and clock_stop_force may be changed either by shifting in new control data through the TAP or by asserting a hard test reset (jtag_trst_l) which will reset the bits to 0.

The Clock Control register is a 3-bit shift register which is used to control the generation of capture clocks (in the Capture-DR state) when using the ATPG instruction. (See *Section 12.4.2 The ATPG Instruction*) Bit [0] controls the generation of the boundary scan capture enable signal (bscan_cdr) and bit [1] and [2] control the generation of iscan_clk1 (psyclk) and iscan_clk2 (upaclk), respectively. This logic may be reset by asserting a test reset (either hard or soft).

The two chains are muxed through ccr_tdo, which is controlled by the Clock Stop register enable signal, cs_select_l.

12.2.10 Clock Stop Logic

This block implements the clock stopping logic used by the Clock Control Register. The module generates the mux select signals which are used to mux in the capture clocks (and mux out the functional clocks) during scan mode.

12.2.11 TDO MUX logic

This block implements the muxing of the signal which is to appear at the TDO output pin. It has one flop to ensure that changes on the TDO pin happen on the falling edge of jtag_tclk when the data is not being shifted in the data registers. When data is not being shifted through the chip, TDO is set to a high impedance state. (The jtag_tdo_en signal is generated by the TAP controller logic since it is based on the state of the JTAG FSM.)

This block also contains logic which muxes together the special ATPG chain.

12.3 Scan Chains

U2P has several scan chains which are controlled by different instructions in the TAP controller. A summary of the accessible chains and their lengths is provided in Table 12-5.

Table 12-4 U2P scan chains

Scan Chain Name	Chain Length
Boundary	643
Internal	7039
atpg	7685
id	32
RUNBIST	30
ccr	3
cs	2
bypass	1

12.3.1 Boundary Chain

The boundary chain is IEEE 1149.1-1990 (JTAG) compliant. The described earlier, the TAP controller fully supports the required Bypass, Sample/Preload and Extest instructions, as well as providing Idcode and Intest instructions.

It should be noted that the signals PSYCLOPS_CLK, PSYCLOPS_CLKR, UPA_CLK and UPA_CLK_L (clock signals which feed the PLL) are not scannable due to the impact on the PLL feedback loop.

12.3.2 The Internal Scan Chain

The internal scan chain is a chain made up of all the sequential elements within the core logic of the chip. For U2P, this also includes the registered I/O, which resides in the boundary ring, but are still clocked by the internal system clocks.

12.3.3 ATPG Chain

The ATPG chain is primarily made up of the internal scan chain and boundary scan chain and the Clock control register. Including the boundary chain gives us the ability to apply ATPG vectors to the chip in-system.

12.4 Special JTAG Instructions

In addition to the mandatory instructions U2P JTAG implements some special instructions.

12.4.1 INTEST

Intest can be used to apply stimulus to test the on chip logic when the chip sits on a board. This requires that the core be driven off the input boundary scan cells and the core drives the output boundary scan cells. Clocks must be applied either from a tester or via the TAP controller using either the Int_OMC or ATPG instructions (by cycling through Capture-DR without entering Shift-DR.) Intest can also be used to apply burn-in vectors if the burn-in tester is pin limited and can't accommodate all the U2P pins.

12.4.2 The ATPG Instruction

The ATPG instruction is used to apply ATPG vectors to U2P. As described in *Section 12.3.3 ATPG Chain*, the ATPG chain includes the registers in both the internal scan chain and boundary chain. During Shift-DR, both chains are loaded with a known state, the core being driven off the input boundary scan cells rather than the I/O. During Capture-DR, outputs are captured on the output boundary scan cells. Thus, ATPG vectors can be applied to a chip in-system.

Like the Intscan instruction, the ATPG utilizes an unusual clocking scheme in order to address the multiple clock domains. However, the ATPG also muxes in the 3-bit Clock Control register in order to select which of the 3 time domains to clock. (See *Section 12.2.9 Clock Control Registers*).

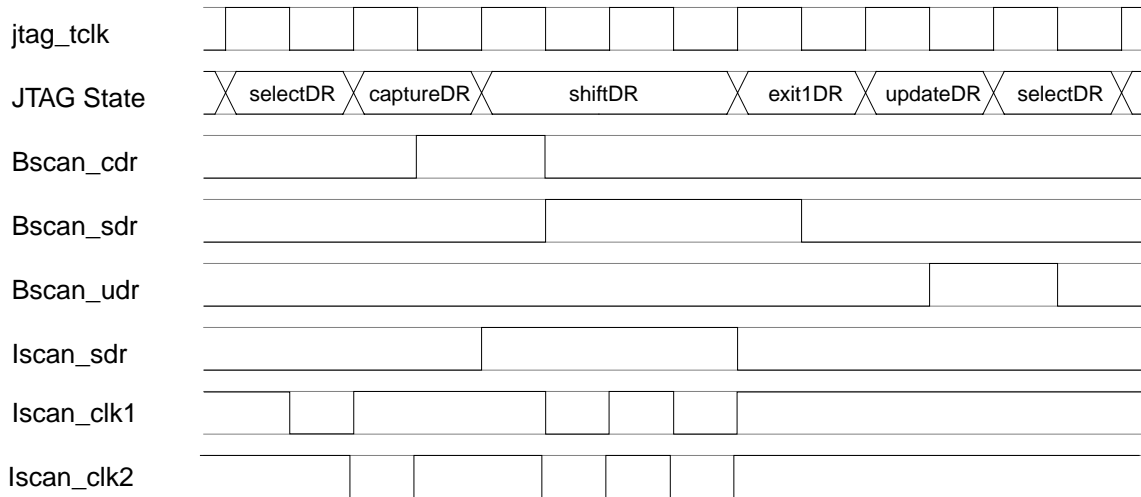

Figure 12-3 JTAG control signals during ATPG instruction

12.4.3 The RUNBIST Instruction

U2P will be implementing Built-In Self-Test (BIST) as a means of testing the on-chip memory cells which are more difficult to access via internal scan. The instruction initiates the tests which are run while the TAP state machine is in Run-Test/Idle. Once a specified time has elapsed, the results are captured into the RUNBIST data register which is connected between TDI and TDO.

12.5 Test Coverage Information

12.5.1 ATPG

Total parallel vectors 1357

Total Fault Coverage 95.92%

Testable Fault Coverage 99.47%

12.5.2 BIST

The actual BIST control logic (including state machines, address, pattern generators and compare logic) is not contained within the JTAG TAP controller. U2P uses a shared resource methodology to reduce area cost. Testable memories are grouped by address size. There is a single control state machine and a single set of address and pattern generators. Compare logic is duplicated for each BISTed RAM. All test result flags (BIST flags) are registered and accessible via the TAP controller.

The BIST control logic is based on Lucent's standard BIST algorithm which provides 100% fault coverage for stuck-at faults, transition faults, stuck-at-open faults, multi-access port faults, static single coupling faults, dynamic single coupling faults, linked transition and coupling faults, and addressing faults.

There are a total of 30 register files which are tested via BIST.

Table 12-5 BIST register files

Type	Instance
R8X36	MRG.MB.MBL
R8X36	MRG.MB.MBU
R8X32	PBMA.dp.drb.rdhi
R8X32	PBMA.dp.drb.rdlo
R16X36	PBMA.dp.dwb.rdhi
R16X36	PBMA.dp.dwb.rdlo
R8X36	PBMA.dp.pwb.rdhi
R8X36	PBMA.dp.pwb.rdlo
R8X32	PBMB.dp.drb.rdhi
R8X32	PBMB.dp.drb.rdlo
R16X36	PBMB.dp.dwb.rdhi
R16X36	PBMB.dp.dwb.rdlo
R8X36	PBMB.dp.pwb.rdhi
R8X36	PBMB.dp.pwb.rdlo
R8X32	STCA.mrp.fill_q.drd_data0
R8X33	STCA.mrp.fill_q.drd_data1
R8X32	STCA.mrp.fsh_q.drd_data0
R8X33	STCA.mrp.fsh_q.drd_data1
R8X32	STCB.mrp.fill_q.drd_data0

Table 12-5 BIST register files (Continued)

Type	Instance
R8X33	STCB.mrp.fill_q.drd_data1
R8X32	STCB.mrp.fsh_q.drd_data0
R8X33	STCB.mrp.fsh_q.drd_data1
R16X36	UPA.URD.u_pfifo_dmawr.dmawr_fifo_l
R16X36	UPA.URD.u_pfifo_dmawr.dmawr_fifo_u
R8X36	UPA.URD.u_pfifo_piord.u_pfifo_piord_h
R8X36	UPA.URD.u_pfifo_piord.u_pfifo_piord_l
R16X33	UPA.URD.u_ufifo_dmard.u_ufifo_dmard_h
R16X32	UPA.URD.u_ufifo_dmard.u_ufifo_dmard_l
R16X32	UPA.URD.u_ufifo_piowr.u_ufifo_piowr_h
R16X32	UPA.URD.u_ufifo_piowr.u_ufifo_piowr_l

The following register files are tested by applying the BIST algorithm via directed functional tests.

Table 12-6 Non-BIST register files

Type	Instance
R28X5	MDU.IDA.INR
S16X28	MMU.u_mmu_tlb.u_mmu_ram
B12832	STCA.dat.dt_data_ram.word_slice0
B12832	STCA.dat.dt_data_ram.word_slice1
R16X6	STCA.tag.lrm
R16X28	STCA.tag.prm
B12832	STCB.dat.dt_data_ram.word_slice0
B12832	STCB.dat.dt_data_ram.word_slice1
R16X6	STCB.tag.lrm
R16X28	STCB.tag.prm

Programmer's Model

This chapter documents the software visible features of U2P.

All of the addresses shown in this chapter are 33-bit offsets within U2P's UPA space, and are not full physical addresses. For systems in which U2P occupies the main I/O UPA port, the full physical address is constructed by adding 0x1FE.0000.0000 to the addresses shown here.

Terms and Abbreviations Used:

R -	Read only
W -	Write only
R/W -	Read/Write
R/W1C -	Read/Write with 1 to clear



Warning – Registers which are designated as Write Only may be read, but the data returned is UNDEFINED. No error is reported for such an access. Software should never rely on the value returned. Writes to Read Only registers have no effect. No error is reported for such an access.

13.1 Internal Registers

Register accesses to U2P can be in any size from one byte up to 8 bytes. Sizes and locations for the registers are given in the sections which follow. Reads of any size up to 8 bytes to any register are supported regardless of whether reads of that size makes sense. Writes of any size up to 8 bytes are also supported regardless of whether writes of that size makes sense. Writes of any size MAY corrupt unwritten bits in the register (i.e., writes may result in all 8 bytes being written regardless of

the indicated write size). Software must insure that only the proper sized accesses are used. No hardware checking is performed. Burst access to U2P registers is not permitted and will result in an error return for reads, and silent failure for writes.

Addresses which are not specified below should be neither read nor written by software. Reads will return undefined data, which software should never rely upon. Writes to such addresses may corrupt data contained in other registers.

As a general rule, the appropriate part of U2P must be inactive when changes are made to important control registers. This includes ensuring that there are no DMA transactions active on the corresponding PCI bus segment when the streaming buffer control register or PBM control/status register is modified. There should be no DMA transactions active on either bus when the IOMMU control register is modified, and there should be no DMA or interrupts active when the U2P control/status register or the UPA configuration register are modified.

13.1.1 U2P Control/Status Register

Table 13-1 Offset of Control Register

Register	Offset	Access Size
U2P Control Register	0x0.0000.0010	8 bytes

Table 13-2 U2P Control Register

Field	Bits	Description	Type
IMPL	63:60	Implementation number of U2P	R
VER	59:56	Revision number of this implementation. 0x0 = Psycho pass 1 0x1 = Psycho pass 2 0x2 = Psycho pass 3 (never manufactured) 0x3 = Psycho+ pass 3 0x4 = Psycho+ pass 3.1	R
MID	55:51	UPA Module ID for U2P. Software must set up correct MID value before allowing U2P to generate interrupts or DMA. Reset to 0xf.	R/W

Table 13-2 U2P Control Register (Continued)

Field	Bits	Description	Type
IGN	50:46	Interrupt Group Number; this field supplies the upper 5 bits of the 11-bit Interrupt Number Offset in the first word of interrupt packets generated by U2P. Reset to 0.	R/W
RESERVED	45:4	Reserved, read as 0	R
APCKEN	3	UPA Address parity check enable. When set, any parity error detected results in a P_FERR reply. When clear, parity errors are logged in APERR bit, but transaction completes normally. Reset to 0.	R/W
APERR	2	Incoming UPA address parity error. Persistent across reset. Initial value upon power-up is undefined. Set regardless of value of APCKEN.	R/W1C
IAP	1	Invert UPA address parity. Reset to 0. U2P generates odd parity when this bit is set to 0 and even parity when set to 1.	R/W
MODE	0	When set to 0, it enables full-handshaking between UPA and PCI clocks. When set to 1, it enables performance mode which assumes that $UPA_{CLK} > 0.9 * PSY_{CLK}$ (calculated limit - not proven in the lab). Set to 0 upon reset.	R/W

The design of U2P is optimized with the assumption that UPA is running faster than U2P clock. This assumption is true in normal operation of existing systems. However, in the debug or bringup stage of a system, this assumption may not be true. The “MODE” bit, which enables full-handshaking between UPA and PCI when set to 0, allows the UPA to run slower than the U2P clock at the expense of performance.

13.1.2 UPA Registers

Table 13-3 Offset of UPA Registers

Register	Offset	Access Size
UPA Port ID Register	0x0.0000.0000	8 bytes
UPA Configuration Reg	0x0.0000.0008	8 bytes

13.1.2.1 UPA Port ID Register

This register includes information about identification and capability of U2P UPA interface. This register is read-only.

Table 13-4 UPA Port ID Register

Field	Bits	Description	Type
Cookie	63:56	Value is 0xFC, which is the FCODE for FERR. Software attempts to read this register as FCODE will be readily identifiable as errors.	R
Reserved	55:35	Reserved, read as 0.	R
ECCNotValid	34	Indicates whether port can generate ECC when sourcing data. Hardwired to 0, indicating that ECC will be generated.	R
ONEREAD	33	Set if the slave port can allow only one outstanding slave read P_REQ transaction at a time. This bit is hardwired to 0, indicating multiple reads allowed.	R
Reserved	32:31	Reserved and reads as 0. Would encode PINT_RDQ for ports implementing this feature.	R
PREQ_DQ	30:25	Specifies the size of data queue in 16-byte unit. This field is 0x8 for U2P which has 128 bytes of data queue.	R

Table 13-4 UPA Port ID Register (Continued)

Field	Bits	Description	Type
PREQ_RQ	24:21	Specify the size of PREQ_RQ queue. U2P can support 2 pending PREQ, this field is 0x2.	R
UPACAP	20:16	Bit <16>: Set if the port has master capability, set to 1. Bit <17>: Set if the port has a cache, set to 0. Bit <18>: Set if port interrupts via UPA_Slave_Int_L signal, set to 0. Bit <19>: Set if the port can generate interrupt, set to 1. Bit <20>: Set if the port can service interrupt, set to 0.	R
JEDEC	15:00	JEDEC identification 0x1954 for all passes of U2P	R

13.1.2.2 UPA Configuration Register

This register indicates the queue sizes for each class of UPA request. Please refer to the UPA Architecture manual for the description of classes. U2P only uses one request class (class 0) for its transfers. The depth of queue supported by SC for U2P is 2, therefore SCIQ0 field should be programmed with 0x2. The initial value after reset is 0x1.

Table 13-5 UPA Configuration Register

Field	Bits	Description	Type
Reserved	63:8	Reserved, read as 0 and write has no effect.	R
SCIQ1	7:4	Unused. Read as 0 and write has no effect.	R
SCIQ0	3:0	Size of input request queue for one master class in SC. Software should set it to 0x2 during initialization. ¹	R/W

1. Note: Software must insure that no DMA is taking place when this field is changed. Once set, the value may not be reduced; it can only be increased.

13.1.3 ECC Registers

Table 13-6 Offset of ECC Registers

Register	Offset	Access Size
ECC Control Register	0x0.0000.0020	8 bytes
UE AFSR	0x0.0000.0030	8 bytes
UE AFAR	0x0.0000.0038	8 bytes
CE AFSR	0x0.0000.0040	8 bytes
CE AFAR	0x0.0000.0048	8 bytes

13.1.3.1 ECC Control Register

This register controls enable/disable of ECC checking and generation of ECC error related interrupts. All bits are 0 upon reset.

Table 13-7 ECC Control Register

Field	Bits	Description	Type
ECC_EN	63	Enables ECC Checking. ECC Generation is always enabled.	R/W
UE_INTEN	62	Enable interrupt generation on uncorrectable error (UE).	R/W
CE_INTEN	61	Enables interrupt on correctable ECC errors (CE).	R/W

Note – The timing of changes to these enable bits when a PIO write is performed is somewhat indeterminate. If software wants to ensure that a change takes effect before proceeding, it should follow the PIO write by a PIO read of this register.

The following table shows how the ECC_EN and UE_INTEN/CE_INTEN controls the ECC checking, error handling in U2P.

Table 13-8 ECC Error Reporting

ECC_EN	INTEN	Description
0	X	No ECC checking and reporting, every UPA transaction proceed as if there is no ECC error. Data flows through from UPA to PCI bus.
1	0	ECC checking will be done, but no interrupt will be sent on ECC error. UE on PIO write will not be performed on PCI bus, UE on DVMA read will terminate PCI access with target-abort Error is logged in ARSR/AFAR but no interrupt is generated. Software should clear error status before enabling interrupt.
1	1	U2P sends interrupt on ECC error. UE on PIO write will not be performed on PCI bus, UE on DVMA read will terminate PCI access with target-abort.

13.1.3.2 Uncorrectable Error Asynchronous Fault Status/Address Register

Any uncorrectable ECC error detected by the UPA interface of U2P will log the error in the UE AFSR/AFAR. Uncorrectable errors can happen during PIO write, DVMA read or DVMA partial write. Two sets of status bits are defined in this register. Bits <63:61> are the primary error status and bits <60:58> are the secondary status. One and only one of the primary error status can be set at any time. Primary error status can be set only when either:

- none of the primary error condition exists prior to this error.
- a new error is detected at the same time software is clearing the primary error; the same time means on coincident clock cycles. Setting takes precedence over clearing.

Secondary bits are set whenever a primary bit is set (one and only one primary bit can be set at a time). The secondary bits are cumulative and always indicate that information has been lost as no address information has been captured. Setting of the primary error bits is independent.

The AFAR and bits <47:23> of AFSR log address and status of the primary UE. Further UE will not be logged into these bits until software clears the primary error, which makes the AFAR and part of the AFSR available to log new error. An interrupt is generated whenever the AFAR logs the new error address.

Table 13-9 UE AFSR

Field	Bits	Description	Type
P_PIO	63	Set if primary UE is caused by PIO write	R/W1C
P_DRD	62	Set if primary UE is caused by PCI DVMA read	R/W1C
P_DWR	61	Set if primary UE is caused by PCI DVMA write	R/W1C
S_PIO	60	Set if secondary UE is caused by PIO write	R/W1C
S_DRD	59	Set if secondary UE is caused by PCI DVMA read	R/W1C
S_DWR	58	Set if secondary UE is caused by PCI DVMA write	R/W1C
Reserved	57:48	Reserved, read as 0.	R
BYTEMASK	47:32	16-bit UPA bytemask for the failing transaction	R
DW_OFFSET	31:29	Offset of doubleword containing ECC error in 64 byte block, relative to PA modulo 64 bytes.	R
UPA_MID	28:24	UPA MID that causes the error transaction	R
BLK	23	Set to 1 if the error transaction was a block read or write, in which case BYTEMASK is not valid.	R
Reserved	22:0	Reserved, read as 0.	R

Table 13-10 UE AFAR

Field	Bits	Description	Type
Reserved	63:41	Reserved, read as 0.	R
UE_PA	40:00	Physical address of error transaction	R

13.1.3.3 Correctable Error Asynchronous Fault Status/Address Register

U2P logs the correctable ECC error in the CE AFSR/AFAR. Correctable errors can happen during PIO write, DVMA read or DVMA partial write. Two sets of status bits are defined in this register. Bits <63:61> are the primary error status and bits <60:58> are the secondary error status. One and only one of the primary error status can be set at any time. Primary error status can be set only when either:

- none of the primary error condition exists prior to this error.
- a new error is detected at the same time software is clearing the primary error; the same time means on coincident clock cycles. Setting takes precedence over clearing.

Secondary bits are set whenever a primary bit is set (one and only one primary bit can be set at a time). The secondary bits are cumulative and always indicate that information has been lost as no address information has been captured. Setting of the primary error bits is independent.

The AFAR and bits <55:23> of AFSR log address and status of the primary CE. Further CE will not be logged into these bits until software clears the primary error, which makes the AFAR and part of the AFSR available to log new error. An interrupt is generated whenever the AFAR logs the new error address.

Table 13-11 CE AFSR

Field	Bits	Description	Type
P_PIO	63	Set if primary CE is caused by PIO access	R/W1C
P_DRD	62	Set if primary CE is caused by PCI DVMA read	R/W1C
P_DWR	61	Set if primary CE is caused by PCI DVMA write	R/W1C
S_PIO	60	Set if secondary CE is caused by PIO access	R/W1C
S_DRD	59	Set if secondary CE is caused by PCI DVMA read	R/W1C
S_DWR	58	Set if secondary CE is caused by PCI DVMA write	R/W1C
Reserved	57:56	Reserved, read as 0.	R
E_SYND	55:48	CE Syndrome bits	R
BYTEMASK	47:32	16-bit UPA bytemask for failing transaction	R
DW_OFFSET	31:29	Offset of doubleword containing ECC error in 64 byte block, relative to PA modulo 64 bytes.	R

Table 13-11 CE AFSR (Continued)

Field	Bits	Description	Type
UPA_MID	28:24	UPA MID that causes the error transaction	R
BLK	23	Set to 1 if the error transaction was a block transaction, in which case the BYTEMASK field is not valid.	R
Reserved	22:00	Reserved, read as 0.	R

Table 13-12 CE AFAR

Field	Bits	Description	Type
Reserved	63:41	Reserved, read as 0.	R
UE_PA	40:00	Physical address of error transaction	R

13.1.4 DMA Scoreboard Diagnostic Support

Table 13-13 Offset of DMA Scoreboard Diagnostic Access

Register	Offset	Access Size
DMA Scoreboard Diag Reg 0	0x0.0000.A000	8 bytes
DMA Scoreboard Diag Reg 1	0x0.0000.A008	8 bytes

The DMA Scoreboard stores information associated with outstanding DMA transactions. Software can perform PIO accesses to the DMA Scoreboard SRAM for Diagnostic or status tracking purposes. Note the VALID bit is read-only, write has no effect. Reading the DMA Scoreboard while DVMA is in progress may get stale information. U2P can generate maximum of two pending UPA transactions, two entries are supported in U2P as indicated in Table 13-13. The ordering of the registers is not significant and they do not form a FIFO. Therefore, any transaction can be in either register. The valid bit must be checked to determine whether a valid entry exists.

Table 13-14 DMA Scoreboard Diagnostic Access

Field	Bits	Description	Type
VALID	63	Indicate this entry has valid transaction pending	R
C	62	Set if the pending transaction is mapped cacheable	R/W
READ	61	Set if the pending transaction is read	R/W
TAG	60:57	Pending transaction identification	R/W
ADDR	56:19	Physical address bits <40:3> of the pending transaction	R/W
BYTEMASK	18:3	Bytemask of the pending transaction (only valid if transaction is marked non-cacheable, will be set to 0 for a block transaction to non-cacheable space).	R/W
SRC	2:0	Source of UPA DMA transactions 0x0 = IOMMU 0x1 = Merge Buffer 0x2 = Streaming Cache A 0x3 = Streaming Cache B 0x4 = PCI Bus A module 0x5 = PCI Bus B module 0x6 = Mondo Interrupt Dispatch Unit	R/W

Note – The address stored in the DMA scoreboard is the address of the original DMA transaction, not necessarily the address of the transaction performed on the UPA. In particular, for partial line writes, U2P issues a 64-byte aligned Read To Own transaction on the UPA, but the DMA scoreboard reflects the 8-byte aligned address of the original DMA write request.

13.1.5 PCI Bus Module

U2P has two independent PCI Bus Modules (PBM), each with a set of control registers. These registers control aspects of U2P's PCI operations that are not defined by the PCI specification. Each PBM also has a number of registers in PCI Configuration Space which are defined by the PCI specification.

Table 13-15 Offset of PBM Registers

Register	Offset	Access Size
PCI Bus A Control/Status Register	0x0.0000.2000	8 bytes
PCI Bus A AFSR	0x0.0000.2010	8 bytes
PCI Bus A AFAR	0x0.0000.2018	8 bytes
PCI Bus A Diagnostic Register	0x0.0000.2020	8 bytes
PCI Bus B Control/Status Register	0x0.0000.4000	8 bytes
PCI Bus B AFSR	0x0.0000.4010	8 bytes
PCI Bus B AFAR	0x0.0000.4018	8 bytes
PCI Bus B Diagnostic Register	0x0.0000.4020	8 bytes

Note – Although these registers are part of the PBM blocks, which are “little-endian”, the bit definitions below assume “big-endian” type accesses.

13.1.5.1 PCI Control/Status Register

Note – There are an unequal number of PCI devices controlled by each PBM. PBM A supports 4 devices, PBM B supports 6 devices. Some of the bits in the PCI Control/Status Register are replicated for each supported device. The register description below documents the maximum number of devices. Bits for unavailable devices should be considered reserved, are read-only, and will read back as 0.

Table 13-16 PCI Control and Status Register

Field	Bits	Description	R/W
Reserved	63:36	Reserved, read as 0.	R
PCI_SBH_ERR	35	PCI streaming byte hole error Set to 1 if a byte hole is detected during a streaming DMA write. Reset to 0.	R/W1C
PCI_SERR	34	Set when SERR# signal is sampled asserted on the PCI bus	R/W1C
PCI_SPEED	33	PCI bus speed 0 = U2P clock / 2 1 = U2P clock The value of this bit reflects the status of the bus speed input pin. It is calculated by motherboard circuitry at power-on, based on capabilities of plugged in devices.	R
Reserved	32:22	Reserved, Read as 0.	R
ARB_PARK	21	PCI bus arbitration parking enable 0 = no parking 1 = previous bus owner parked (including CPU) Reset to 0	R/W
Reserved	20:11	Reserved, read as 0.	R
SBH_INT_EN	10	Streaming byte hole interrupt enable 0 = PCI error interrupt will not be issued for streaming byte hole errors 1 = PCI error interrupt will be issued for streaming byte hole errors, if ERRINT_EN is also set to 1. Reset to 0	R/W
WAKEUP_EN	9	Power Management Wakeup Enable Control; 1 for power management wakeup enabled, 0 for disabled. Resets to 0	R/W

Table 13-16 PCI Control and Status Register (Continued)

Field	Bits	Description	R/W
ERRINT_EN	8	Enable PCI error interrupt 0 = PCI error interrupt disabled 1 = PCI error interrupt enabled Reset to 0	R/W
Reserved	7:6	Reserved, read as 0.	R
ARB_EN<5:0>	5:0	PCI DVMA arbitration enable. One independent bit for each supported device on the bus. ARB_EN<5:0> assigned to slots 5 through 0 respectively. 0 = Bus requests from corresponding PCI device are ignored. 1 = Bus requests from corresponding PCI device are honored. Reset to 0x0	R/W

WAKEUP_EN

Used by system software when putting various parts of the system to sleep. When set to 1, any attempt by an enabled PCI device (ones with ARB_EN == 1) to arbitrate for the PCI bus will result in an interrupt packet being delivered to a target for the purpose of waking up the system. Refer to the interrupt section for more details. Arbitration for PCI devices is inhibited as long as this bit is set; in other words, with (WAKEUP_EN == 1) the system behaves as though (ARB_EN<5:0> == 0).

Additionally, this bit enables a divide by 1000 prescaler for Timer/Counter 0 thereby changing it from incrementing once per microsecond to once per millisecond. The divide by 1000 prescaler is enabled when the WAKEUP_EN bit is set in either or both of the PBM blocks.

13.1.5.2 PCI Asynchronous Fault Status/Address Registers

PCI AFSR/AFAR record error information related to PIO writes to PCI slave devices. Only asynchronous errors reported through interrupt are recorded in these registers. Asynchronous errors include any PIO write access terminated by Master Abort, Target Abort, or excessive retries, as well as any PIO write during which a parity error was signaled on the PCI bus. Although status bits for Master Abort, Target Abort and Parity Error exist in the PCI Configuration Registers for each PBM, they are duplicated here to provide the additional functionality of identifying which error occurred first in the case of multiple errors, and associating an address with that error.

Two sets of status bits are defined in this register. Bits <63:60> are the primary error status and bits <59:56> are the secondary error status. One and only one of the primary error status can be set at any time. Primary error status can be set only when either:

- none of the primary error conditions exist prior to this error.
- a new error is detected at the same time software is clearing the primary error.

Secondary bits are set whenever a primary bit is set (one and only one primary bit can be set at a time). The secondary bits are cumulative and always indicate that information has been lost as no address information has been captured. Setting of the primary error bits is independent.

The AFAR and bits <47:37> of AFSR log address and status of the primary PCI PIO error. Further PCI PIO error will not be logged into these bits until software clears the primary error, which makes the AFAR and part of the AFSR available to log new error. An interrupt is generated whenever the AFAR logs the new error address.

Table 13-17 PCI AFSR

Field	Bits	Description	R/W
P_MA	63	Set if primary error detected is Master Abort	R/W1C
P_TA	62	Set if primary error detected is Target Abort	R/W1C
P_RTRY	61	Set if primary error detected is excessive retries	R/W1C
P_PERR	60	Set if primary error detected is parity error	R/W1C
S_MA	59	Set if secondary error detected is Master Abort	R/W1C
S_TA	58	Set if secondary error detected is Target Abort	R/W1C
S_RTRY	57	Set if secondary error detected is excessive retries	R/W1C
S_PERR	56	Set if secondary error detected is parity error	R/W1C
Reserved	55:48	Reserved, read as 0.	R
BYTEMASK	47:32	Bytemask of failed primary transfer. Only valid if BLK is 0.	R
BLK	31	Set to 1 if failed primary transfer was a block read or write	R
Reserved	30	Reserved, read as 0.	R
MID	29:25	UPA MID that causes error transaction	R
Reserved	24:00	Reserved, read as 0.	R

Table 13-18 PCI AFAR

Field	Bits	Description	R/W
Reserved	63:41	Reserved, read as 0.	R
PA	40:00	Physical address of error transaction	R

13.1.5.3 PCI Diagnostic Register

Table 13-19 PCI Diagnostic Register

Field	Bits	Description	R/W
Reserved	63:7	Reserved, read as 0.	R
DIS_RETRY	6	Disable retry limit. When set to 1, U2P will not abort PIO operations after 16,384 retries, but will continue indefinitely. Reset to 0	R/W
DIS_INTSYNC	5	Disable DMA write / interrupt synchronization. When set to 1, interrupts will not wait until associated DMA is complete before proceeding. Reset to 0	R/W
DIS_DWSYNC	4	Disable DMA write / PIO read synchronization. When set to 1, PIO read completion does not wait for prior DMA writes to complete. Reset to 0	R/W
I_DMA_D_PAR	3	Invert DMA data parity 0 = Correct parity asserted 1 = Incorrect parity asserted for all PCI DMA read data phases. Both the regular parity signal and the 64-bit parity extension are effected. Reset to 0	R/W
I_PIO_D_PAR	2	Invert PIO data parity 0 = Correct parity asserted 1 = Incorrect parity asserted for all PCI PIO write data phases. Reset to 0	R/W
I_PIO_A_PAR	1	Invert PIO address parity 0 = Correct parity asserted 1 = Incorrect parity asserted for all PCI PIO address phases. Reset to 0	R/W
LPBK_EN	0	Loopback enable 0 = Loopback disabled. 1 = Loopback enabled. Reset to 0	R/W

Loopback Mode

When LPBK_EN is set to 1, U2P can act as both the initiator and target of a PCI transaction. The immediate effect of Loopback Mode is that PCI address bit [31] will

be set in all outgoing PIO transactions. This causes the PIO's to match U2P's DMA address range, and U2P will respond accordingly.

Any transaction that can be both legally generated and accepted by U2P may be looped back in this fashion, e.g. PIO's to Config or IO space will not loop back, but PIO reads/writes of Memory space will cause DMA reads/writes.



Warning – When Loopback Mode for a PCI bus is enabled, all normal PIO access to that bus becomes disabled.

13.1.6 PBM Configuration Space

Each PBM contains a configuration header whose format is specified by the PCI Specification. The registers in the configuration header are accessed via PCI Configuration Address Space. Each PBM is considered to be device 0, function 0 on its PCI bus. After a reset, PBM A will be PCI bus 1, and PBM B will be PCI bus 0.

Table 13-20 Default offset of PCI Bridge Configuration Spaces

Register	Offset
PBM A Bridge Device Config Space	0x0.0101.0000 - 0x0.0101.00FF
PBM B Bridge Device Config Space	0x0.0100.0000 - 0x0.0100.00FF

Note – These are the offsets in effect after reset. However, since the PCI bus number of each PBM can be changed by software, the actual offset for these spaces may be different than what is listed above.

Note – The PCI Configuration Address Space is a little-endian address space. When accessing configuration space registers, software should take advantage of one of the SPARC V9 little-endian support mechanisms to get proper byte ordering. These mechanisms include little-endian ASI's or MMU support for marking pages little-endian.

Table 13-21 lists the configuration header registers (one set for each PBM), as defined by the PCI specification and PCI System Design Guide. Several of the registers are not implemented in U2P which is indicated by shading in the table. The rule used is that any optional register for which equivalent information exists elsewhere is not implemented.

Table 13-21 Configuration Space Header Summary

Register	Offset	Size
Required PCI device configuration header:		
Vendor ID	0x00	2 bytes
Device ID	0x02	2 bytes
Command	0x04	2 bytes
Status	0x06	2 bytes
Revision ID	0x08	1 byte
Programming I/F Code	0x09	1 byte
Sub-class Code	0x0A	1 byte
Base Class Code	0x0B	1 byte
Cache Line Size	0x0C	1 byte
Latency Timer	0x0D	1 byte
Header Type	0x0E	1 byte
BIST	0x0F	1 byte
Base Address	0x10-0x27	Varies
Reserved	0x28-0x2F	n/a
Expansion ROM	0x30	4 bytes
Reserved	0x34-0x3B	n/a
Interrupt Line	0x3C	1 byte
Interrupt Pin	0x3D	1 byte
MIN_GNT	0x3E	1 byte
MAX_LAT	0x3F	1 byte
Optional bridge configuration header:		
Bus Number	0x40	1 byte
Subordinate Bus Number	0x41	1 byte
Reserved	0x42-0xFF	n/a
Disconnect Counter	Unspecified	1 byte

Table 13-21 Configuration Space Header Summary (Continued)

Register	Offset	Size
Bridge Command/Status	Unspecified	4 bytes
Bridge Memory Base Address	Unspecified	4 bytes
Bridge Memory Limit Address	Unspecified	4 bytes
DOS Read Attributes	Unspecified	2 bytes
DOS Write Attributes	Unspecified	2 bytes
Bridge I/O Base Address	Unspecified	2 bytes
Bridge I/O Limit Address	Unspecified	2 bytes

Note – The sizes listed in the table above are just the logical size for each register. Actual PIO access to the registers can be in any size from 1 to 8 bytes.

13.1.6.1 Vendor ID

Read only, VendorID<15:0> = 0x108E.

13.1.6.2 Device ID

Read only, DeviceID<15:0> = 0x8000.

13.1.6.3 Command Register

Table 13-22 Command Register

Field	Bits	Description	R/W
Reserved	15:10	Reserved, read as 0.	R
FAST_EN	9	Enable fast back-to-back cycles to different targets. Hardwired to 0 (disabled).	R
SERR_EN	8	Enable driving of SERR# pin. Reset to 0 (disabled).	R/W
WAIT	7	Enable use of address/data stepping. Hardwired to 0 (disabled).	R
PER	6	Enable reporting of parity errors. Reset to 0 (disabled).	R/W
VGA	5	Enable VGA palette snooping. Hardwired to 0 (disabled).	R
MWI	4	Enables use of Memory Write & Invalidate. Hardwired to 0 (disabled).	R
SPCL	3	Enables monitoring of special cycles. Hardwired to 0 (disabled).	R
MSTR	2	Enables ability to be bus master. Hardwired to 1 (enabled).	R
MEM	1	Enables response to PCI MEM cycles. Hardwired to 1 (enabled).	R
IO	0	Enables response to PCI I/O cycles. Hardwired to 0 (disabled).	R

13.1.6.4 Status Register

Table 13-23 Status Register

Field	Bits	Description	R/W
DPE	15	Set if PBM detects a parity error	R/W1C
SSE	14	Set if PBM signalled a system error. This occurs if the PBM detects a PCI address parity error, or another device asserts SERR#. Reset to 0	R/W1C
RMA	13	Set if PBM receives a master-abort. Reset to 0	R/W1C
RTA	12	Set if PBM receives a target-abort. Reset to 0	R/W1C
STA	11	Set if PBM generates target-abort. Reset to 0	R/W1C
DVSL	10:9	Timing of DEVSEL#. Hardwired to 01 (medium speed response)	R
DPAR	8	Set when parity error occurs while PBM is bus master, if PER in command register also set. Reset to 0	R/W1C
FASTCAP	7	Indicates ability to accept fast back-to-back cycles as target, when the back-to-back transactions are not to the same target. Hardwired to 1 (allowed)	R
UDF_SUPPORT	6	User Definable Feature Support. Hardwired to 0 (no user definable features)	R
66MHZ_CAPABLE	5	Indicates ability to run at 66MHz clock speed. Hardwired to 1 (66MHz capable) for PBMA and 0 for PBMB.	R
Reserved	4:0	Reserved, read as 0	R

13.1.6.5 Revision ID Register

Read only, RevisionID<7:0> = 0x00. This register will always read as 0. The actual revision number for U2P is contained in the U2P Control/Status Register.

13.1.6.6 Programming I/F Code Register

Read only, ProgrammingIFCode<7:0> = 0x00.

13.1.6.7 Sub-class Code Register

Read only, SubclassCode<7:0> = 0x00. (Specifies host bridge device).

13.1.6.8 Base Class Code Register

Read only, BaseClassCode<7:0> = 0x06. (Specifies bridge device).

13.1.6.9 Latency Timer Register

This 8-bit read/write register specifies the value of the latency timer for the PBM as a bus master. Only the top five bits are implemented, giving a timer granularity of 8 PCI clocks. The bottom three bits will read as 0 and should be written as 0. The maximum PIO transfer is 64 bytes, so the latency timer may come into play for transfers to slow targets that insert many wait states. After a reset, the timer will be set to 0x0.

Table 13-24 Latency Timer Register

Field	Bits	Description	R/W
LAT_TMR_HI	7:3	Programmable portion of latency timer. Reset to 0x0	R/W
LAT_TMR_LO	2:0	Read only portion of latency timer. Hardwired to 0x0	R

13.1.6.10 Header Type Register

Table 13-25 Header Type Register

Field	Bits	Description	R/W
MULTI_FUNC	7	Indicates whether the PBM is a multi-function PCI device. Hardwired to 0 (not multi-function)	R
HDR_TYPE	6:0	Defines layout of configuration header bytes 0x10-0x3F. Hardwired to 0 (the only defined value in PCI specification)	R

13.1.6.11 Bus Number

This 8-bit read/write register specifies the number of the PCI bus this bridge resides on. It's value upon reset is 1 for PBM A, and 0 for PBM B.

13.1.6.12 Subordinate Bus Number

This 8-bit read/write register specifies the highest subordinate bus number beneath this bridge. It's value upon reset is 0.

13.1.6.13 Unimplemented Registers

The following registers are defined in the PCI Specification or PCI System Design Guide, but are not implemented in U2P's PBM's for the indicated reasons.

Cache Line Size - The cache line size is fixed at 64-bytes by the UPA architecture.

Base Address Registers - The bridge itself has neither memory nor I/O space. Its configuration space is accessible only from the host and is hard-mapped.

Interrupt Line, Interrupt Pin - Do not apply. Interrupt lines are handled by the RIC ASIC chip.

Min_Gnt, Max_Lat - There is no regular traffic pattern to programmed I/O. Values of zero indicate there are no stringent requirements (true).

Disconnect Counter - This seems to be intended mainly for cases where the other bus (host bus in this case) is potentially very slow. This shouldn't apply to UPA.

Bridge Memory/IO Base and Limit Address - These registers are defined for an entirely flat address space which the UPA and PCI busses cannot abide by.

DOS Attribute Registers - DOS compatibility is not a feature of U2P.

13.1.7 IOMMU Registers

Table 13-26 Offset of IOMMU Registers

Register	Offset	Access Size
IOMMU Control Register	0x0.0000.0200	8 bytes
TSB Base Address Reg	0x0.0000.0208	8 bytes
IOMMU Flush Register	0x0.0000.0210	8 bytes
IOMMU Virtual Addr Diag Reg	0x0.0000.A400	8 bytes
TLB Tag Compare Diag	0x0.0000.A408	8 bytes
IOMMU LRU Queue Diag	0x0.0000.A500 - 0x0.0000.A57F	8 bytes
TLB Tag Diag	0x0.0000.A580 - 0x0.0000.A5FF	8 bytes
TLB Data RAM Diag	0x0.0000.A600 - 0x0.0000.A67F	8 bytes

13.1.7.1 IOMMU Control Register

The Control Register provides means to enable and disable the diagnostic mode, TSB size and page size. It also contains some revision control information.

Table 13-27 IOMMU Control Register

Field	Bits	Description	Type
RESERVED	63:27	Reserved, read as zeros.	R
XLT_ERR_STS	26:25	Reason for most recent translation error: 00 = Protection Error, 01 = Invalid Error, 10 = Time Out Error, 11 = ECC Error (UE).	R
XLT_ERR	24	When set to 1 indicates that the IOMMU has encountered and signaled a translation error. Reset to 0.	R/W
LRU_LCKEN	23	LRU Lock Enable Bit. Reset to 0. When set, only the TLB entry specified by the Lock Pointer can be replaced.	R/W

Table 13-27 IOMMU Control Register (Continued)

Field	Bits	Description	Type
LRU_LCKPTR	22:19	LRU Lock Pointer. Works in conjunction with the LRU Lock Enable bit to limit TLB replacement to a single entry	R/W
TSB_SIZE	18:16	TSB table size measured in the number of 8 byte entries. 0=1K, 1=2K, 2=4K, 3=8K, 4=16K, 5=32K, 6=64K, 7=128K.	R/W
RESERVED	15:3	Reserved, read as zeros.	R
TBW_SIZE ¹	2	Assumed page size during TSB lookup. 0 = 8K page. 1 = 64K page	R/W
MMU_DE	1	Diagnostic mode enable, when set it enables the diagnostic mode. See description of TLB tag diagnostics. Reset to 0	R/W
MMU_EN	0	IOMMU enable bit, when set it enables the translation. Reset to 0	R/W

1. If DVMA mappings are always 8K pages, or mixed 8K and 64K pages, set this bit to '0' so that the index is constructed for 8K lookup. If all DVMA mappings are to 64K pages, set this bit to '1' so that the index is based on 64K pages. When this bit is '0', a 64K mapping should be placed in all 8 TSB entries in which it is indexed.

Table 13-28 Address space size and base address determination.

TSB_SIZE	TBW_SIZ == 0			TBW_SIZ == 1		
	VA Space Size	VA Base Address	TSB Index [3]	VA Space Size	VA Base Address	TSB_Index [3]
0	8 MB	0xFF80.0000	VA<22:13>	64 MB	0xFC00.0000	VA<25:16>
1	16 MB	0xFF00.0000	VA<23:13>	128 MB	0xF800.0000	VA<26:16>
2	32 MB	0xFE00.0000	VA<24:13>	256 MB	0xF0000000	VA<27:16>
3	64 MB	0xFC00.0000	VA<25:13>	512 MB	0xE000.0000	VA<28:16>
4	128 MB	0xF800.0000	VA<26:13>	1 GB	0xC000.0000	VA<29:16>
5	256 MB	0xF000.0000	VA<27:13>	2 GB	0x8000.0000	VA<30:16>
6	512 MB	0xE000.0000	VA<28:13>	not allowed ¹	--	--
7	1GB	0xC000.0000	VA<29:13>	not allowed ¹	--	--

1. Hardware does not prevent illegal combinations from being programmed. If an illegal combination is programmed into the IOMMU, all translation requests will be rejected as invalid.

Address space size and base address are controlled by TSB_SIZE and TBW_SIZE as shown in Table 13-28. shows the same information is a different format. Virtual addresses that are within U2P's DVMA range (0x8000000-0xffffffff) but below the VA base address determined by the value of TSB_SIZE and TBW_SIZE are rejected by the IOMMU, and result in Target Aborts on the PCI bus.

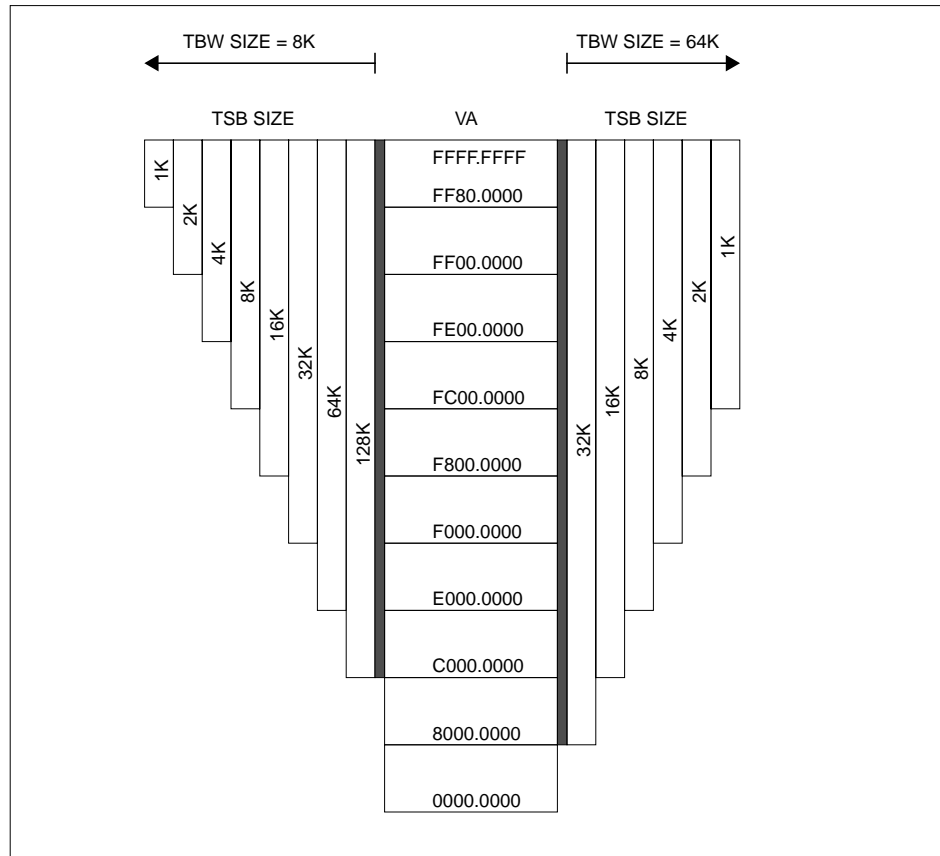

Figure 13-1 Legal DVMA address configurations

TLB locking

For diagnostics and debugging, the IOMMU has the capability of restricting itself to use just a single entry in the TLB. This is controlled by the LRU_LCKEN and LRU_LCKPTR fields of the IOMMU Control Register. To properly turn locking on the following sequence is required:

- Set MMU_EN to 0.

- Set LRU_LCKEN to 1 (must be a separate PIO write).
- Set LRU_LCKPTR to desired value (may be combined with previous PIO).
- Set MME_DE to 1 (may be combined with previous PIO).
- Invalidate all TLB entries.
- Set MMU_EN to 1 and MMU_DE to 0.

To unlock the TLB:

- Set LRU_LCKEN to 0.

13.1.7.2 TSB Base Address Register

The TSB Base Address Register contains the pointer to the first entry of the TSB table. Together with part of the virtual address it uniquely identifies the address where hardware should fetch the TTE from TSB table. The TSB table has to be aligned on 8K boundary. The lower order 13 bits are assumed to be 0x0 during TSB table lookup. Tables larger than 8K bytes are only constrained to be on 8K boundaries rather than having to be size aligned.

Table 13-29 TSB Base Address Register

Field	Bits	Description	Type
RESERVED	63:41	Reserved, read as zeros.	R
TSB_BASE	40:13	Upper 28 bits of the PCI TSB's physical address.	R/W
RESERVED	12:0	Reserved, read as zeros.	R

13.1.7.3 Flush Address Register

This is a write-only pseudo-register to allow software to perform an address based flush of a mapping from the TLB. The data written to this address contains the page number to be flushed. A TLB entry with a matching page number will be invalidated.

Table 13-30 Flush Address Register

Field	Bits	Description	Type
RESERVED	63:32	Reserved, write has no effect.	W
FLUSH_VPN	31:13	31:16 = virtual page number if 64K page; bits 15:13 are don't care. 31:13 = virtual page number if 8K page.	W
RESERVED	12:0	Reserved, write has no effect.	W

Note – No hardware mechanisms exist to solve the potential race between a DVMA translation needing a TLB entry and the write to the Flush Address Register intended to flush that entry. Software must manage the interlock by guaranteeing that no DVMA can be going on to the page which is being flushed.

13.1.7.4 TLB TAG Diagnostics Access

The TLB Tag Diagnostics Access provides diagnostics a path to the 16-entry TLB Tag when the MMU_DE bit in the IOMMU Control Register is turned on.

Table 13-31 TLB Tag Diagnostics Access

Field	Bits	Description	Type
RESERVED	63:25	Reserved, read as zeros.	R
ERRSTS	24:23	Error Status: 00 = Protection Error, 01 = Invalid Error, 10 = Timeout, 11 = ECC Error (UE).	R/W
ERR	22	When set to 1, indicates that there is an error associated with this TLB entry. The specific error is indicated by the ERRSTS field.	R/W
W	21	Writable bit. When set, the page mapped by the TLB has write permission granted.	R/W

Table 13-31 TLB Tag Diagnostics Access (Continued)

Field	Bits	Description	Type
S	20	Stream bit, 1 = page is streamable, 0 = page is not streamable.	R/W
SIZE	19	Page Size, 0=8K and 1=64K.	R/W
VPN	18:0	VPN[31:13]	R/W

Note – Diagnostic accesses should insure that multiple match conditions are not generated. The result of multiple matches is unpredictable.

13.1.7.5 TLB Data RAM Diagnostic Access

The TLB Data Diagnostics Access provides direct PIO accesses to 16 entries of TLB Data RAM. MMU_DE bit in the IOMMU Control Register must be turned on to perform the accesses. Following table shows the information included in the returned data.

Table 13-32 TLB Data RAM Diagnostics Access

Field	Bits	Description	Type
RESERVED	63:31	Reserved, read as zeros.	R
V	30	Valid bit, when set, the TLB data field is meaningful.	R/W
RESERVED	29	Reserved, read as 0 (was local bus bit for SBus).	R/W
C	28	Cacheable bit. 1=Cacheable access, 0=Non-cacheable.	R/W
PA[40:13]	27:0	28-bit Physical Page Number	R/W

13.1.7.6 LRU Queue Diagnostic Access

This LRU queue can be directly accessed by PIO read for diagnostic purpose. The MMU_DE bit in IOMMU Control Register must be set to perform direct access. There are 16 entries in the LRU Queue. Each entry contains a unique value from 0x0 to 0x1F. Entry 0 contains the pointer to a TLB entry which is least recently used, and entry 15 contains the pointer to a TLB entry that is most recently used.

Table 13-33 LRU Entry Diagnostics Access

Field	Bits	Description	Type
RESERVED	63:4	Reserved, read as zeros	R
LRU_DO	3:0	LRU entry selected	R

13.1.7.7 Virtual Address Diagnostic Register

This register is used to set up the virtual address for TLB compare diagnostic. The virtual address is written to this register and the compare results from TLB can be read.

Table 13-34 Virtual Address Diagnostic Register

Field	Bits	Description	Type
RESERVED	63:32	Reserved, read as 0.	R
VPN	31:13	Virtual page number	R/W
RESERVED	12:00	Reserved, read as 0.	R

13.1.7.8 TLB Tag Compare Diagnostic Access

Table 13-35 TLB Tag Comparator Diagnostics Access

Field	Bits	Description	Type
RESERVED	63:16	Reserved, read as zeros.	R
COMP	15:0	TLB tag comparator output for each entry	R

Note – The TLB Tag Comparator Diagnostics Access provides diagnostics a path to the 16-entry TLB Tag Comparator when the MMU_DE bit in the IOMMU Control Register is turned on. Bit 0 represents the comparison result of the first TLB Tag entry, and bit 15 represents the last.

In order to avoid invalid address translation after TLB diagnostics, the valid bits in the TLB should be reset appropriately before doing any meaningful address translation. Diagnostics write to read-only space or read from write-only space will be ignored.

13.1.8 Streaming Buffer Registers

Table 13-36 Offset of Streaming Buffer Registers

Register	Offset	Access Size
Streaming Buffer A Control Reg.	0x0.0000.2800	8 bytes
Streaming Buffer A Page Flush/Invalidate Reg	0x0.0000.2808	8 bytes
Streaming Buffer A Flush Synchronization Reg	0x0.0000.2810	8 bytes
Streaming Buffer B Control Reg.	0x0.0000.4800	8 bytes
Streaming Buffer B Page Flush/Invalidate Reg	0x0.0000.4808	8 bytes
Streaming Buffer B Flush Synchronization Reg	0x0.0000.4810	8 bytes
Streaming Buffer A Data RAM Diagnostic	0x0.0000.B000 - 0x0.0000.B3FF	8 bytes
Streaming Buffer A Error Status Diagnostics	0x0.0000.B400 - 0x0.0000.B7FF	8 bytes
Streaming Buffer A Tag Diagnostics	0x0.0000.B800 - 0x0.0000.B87F	8 bytes
Streaming Buffer A Line Tag Diagnostics	0x0.0000.B900 - 0x0.0000.B97F	8 bytes
Streaming Buffer B Data RAM Diagnostic	0x0.0000.C000 - 0x0.0000.C3FF	8 bytes
Streaming Buffer B Error Status Diagnostics	0x0.0000.C400 - 0x0.0000.C7FF	8 bytes
Streaming Buffer B Page Tag Diagnostics	0x0.0000.C800 - 0x0.0000.C87F	8 bytes
Streaming Buffer B Line Tag Diagnostics	0x0.0000.C900 - 0x0.0000.C97F	8 bytes

13.1.8.1 Streaming Buffer Control Register

This register controls the various functions of the selected streaming buffer.

Table 13-37 Streaming Buffer General Control Register (2 copies)

Field	Bits	Description	Type
Reserved	63:08	Reserved, read as 0	R
LRU_LPTR	7:4	LRU Lock Pointer. Works in conjunction with LRU_LE to restrict all streaming cache replacement operations to use a single entry. Reset to 0	R/W
LRU_LE	3	LRU Lock Enable. Reset to 0. When set, only the entry specified by LRU_LPTR will be victimized.	R/W
RR_DIS	2	Rerun Disable. Reset to 0. When set, the streaming cache will not rerun the PBM on check or put line misses.	R/W
DE	01	Diagnostic Mode enable. Set to "1" to enable diagnostic mode access. This bit is reset to 0.	R/W
SB_EN	00	Streaming buffer enable/disable. Set to "1" to enable Streaming buffer. This bit is reset to 0.	R/W

Streaming cache entry locking

For diagnostics and debugging, each STC has the capability of restricting itself to use just a single entry. This is controlled by the LRU_LE and LRU_LCKPTR fields of the STC Control Register. To properly turn locking on the following sequence is required:

- Set SB_EN to 0.
- Set LRU_LE to 1 (must be a separate PIO write).
- Set LRU_LCKPTR to desired value (may be combined with previous PIO).
- Set DE to 1 (may be combined with previous PIO).
- Invalidate all STC entries.
- Set SB_EN to 1 and DE to 0.

To unlock the STC:

- Set LRU_LE to 0.

13.1.8.2 Streaming Buffer Page Invalidate/Flush Register

This is a write-only pseudo register. It provides a means for software to cause an entry in one streaming buffer with a matching tag to become invalidated/flushed. The data written to this address contains the virtual page number to be used for match comparison. The flush/invalidation is based on 8K page size.

Table 13-38 Streaming Buffer Page Invalidate/Flush Register (2 copies)

Field	Bits	Description	Type
FLUSH_A	31:13	8K virtual page to be invalidated/flushed	W
reserved	12:0	These bits are ignored	W

13.1.8.3 Streaming Buffer Flush Synchronization Register

The Flush Synchronization Register provides a means for software to determine when flush data has entered the coherent memory domain. Data written to this register contains the physical address of the flush flag. Writing to this register triggers U2P to write a 64-byte block of data to FLAG_PA, when all in progress flush operations for the indicated streaming buffer are complete. The first doubleword of the block will be set to 0x1, and the remaining doublewords will be set to 0x0. The low order 6 bits of the FLAG_PA Address will be ignored. Please read the Streaming Buffer chapter for more information of how the synchronization is done.

Table 13-39 Streaming Buffer Flush Synchronization Register (2 copies)

Field	Bits	Description	Type
FLAG_PA	40:06	64-byte aligned physical address for synch update	W
Reserved	05:00	These bits are ignored	W

13.1.8.4 Streaming Buffer Page Tag Diagnostic Access

The Page Tags are directly accessible through PIO access. This can be done only when the DE bit of the corresponding Stream Buffer Control Register is set to 1.

Table 13-40 Streaming Buffer Page Tag Format

Field	Bits	Description	Type
PTPA	59:32	Physical page number (as an 8K page)	R/W
PTVA	31:13	Virtual page number (as an 8K page)	R/W
Reserved	12:02	Reserved, read as 0.	R
PTVD	01	Valid bit for page	R/W
PTRD	00	Read (/write_) bit for page	R/W

Caution – Valid bits on all entries should be reset to “0” after finishing diagnostics of the Page Tag.

13.1.8.5 Streaming Buffer Line Tag Diagnostic Access

The Line Tag contains information related to the line in the streaming buffer. This information can be directly accessed when streaming buffer is in diagnostic mode, DE bit is set in the appropriate Stream Buffer Control Register.

Table 13-41 Streaming Buffer Line Tag Format

Field	Bits	Description	Type
LRU	24:21	LRU index. Provides index of the least recently used streaming cache line at any given time	R
LTSP	20:15	Start pointer for dirty data portion of buffer	R/W
LTLA	14:08	Line address for this entry	R/W
LTEP	07:02	End pointer (+1) for dirty data portion	R/W
LTVD	01	Valid bit for line	R/W
LTFH	00	Fetch Outstanding/Flush Necessary bit	R/W

The LTEP field should be set to zero if the page is readable. If writable, this field should be set to one greater than the end byte address of the dirty data chunk in the data ram (module buffer size of 64 bytes).

Caution – Valid bits on all entries should be reset to “0” after finishing diagnostics of the Line Tag.

13.1.8.6 Streaming Buffer Data RAM Diagnostic Access

There are sixteen 64-byte entries in each Streaming Buffer. Physical address bit <13> selects which Streaming Buffer, bits <9:6> selects the entry number and bits <5:3> selects which 8-byte quantity to access in the entry.

Table 13-42 Streaming Buffer Data RAM Content Format

Field	Bits	Description	Type
DRDA	63:00	Data	R/W

13.1.8.7 Streaming Buffer Error Status Diagnostic Access

Each entry of Streaming Buffer has an error bit associated with it for DMA read operations and another error bit associated with DMA write operations. These bits are only visible to software during diagnostic mode. Each pair of error bits can be accessed at any of 8 different addresses (one for each doubleword in the line - addressing is the same as for the Data RAM diagnostic access), but these different addresses are accessing the same physical bits bit.

Table 13-43 Streaming Buffer Data RAM Error Format

Field	Bits	Description	Type
Reserved	63:2	Reserved	R
DWER	1	DMA write error (PCI parity error) bit	R/W
DRER	0	DMA read error (UPA read reply error) bit	R/W

13.1.9 Interrupts

Interrupts delivered to the processor by U2P have the format shown in Figure 13-2.

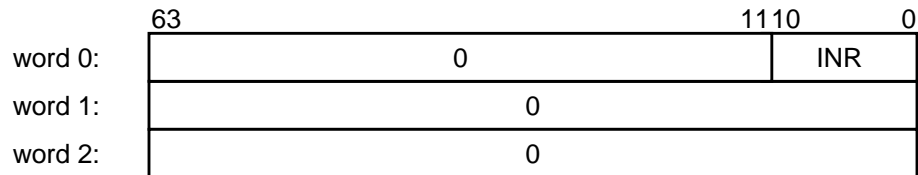

Figure 13-2 U2P Interrupt Format

INR is an 11 bit interrupt number which indicates the source of the interrupt. Where possible, the interrupt is precise (i.e., it points to only one interrupt source). This permits the dispatch of the proper interrupt service routine without any register polling. Bits 11 through 63 of the first word are guaranteed to be 0 for all U2P generated interrupts. Software can use this knowledge to distinguish these interrupts from others such as cross-calls. Words 1 and 2 of the interrupt packet are also guaranteed to be 0.

For each interrupt source supported by U2P, there is an associated interrupt mapping register (with the exception that all interrupts from a single PCI slot share a single mapping register). These mapping registers contain the value of the INR field that U2P will use for each interrupt. There are two formats of mapping registers - partial and full.

For the partial format, the INR portion of the mapping register is read-only, and consists of two parts. The upper 5 bits are the Interrupt Group Number (IGN) which is shared by all interrupts using the partial format. It is read-only in the mapping registers, but is writable via the U2P Control Register (see Table 13-2). The lower 6 bits of the INR are the Interrupt Number Offset (INO). This value is hardcoded by U2P for each interrupt source, as shown in Table 13-44, and is available read-only in the mapping register. For PCI slot interrupt mapping registers, INO<1:0> will always be read as 00.

For the full format, which is only used by the Graphics and UPA expansion interrupts, the full 11-bit INR field is writable, and under software control.

Table 13-44 Interrupt Number Offset Assignments

INO (binary)	INO (hex)	Interrupt Source
0bssnn	00-1f	PCI Bus b Slot ss Interrupt nn b = 0 for bus A, 1 for bus B ss = 00 or 01 for bus A slots, 00-11 for bus B slots nn = 00 for INTA#, 01 for INTB#, 10 for INTC#, 11 for INTD#
100000	20	SCSI
100001	21	Ethernet
100010	22	Parallel port
100011	23	Audio Record
100100	24	Audio Playback
100101	25	Power Fail
100110	26	Keyboard/mouse/serial ¹
100111	27	Floppy
101000	28	Reserved (spare HW int)
101001	29	Keyboard ²
101010	2a	Mouse ²
101011	2b	Serial ²
101100	2c	Timer/Counter 0
101101	2d	Timer/Counter 1
101110	2e	UE
101111	2f	CE
110000	30	PCI Bus A Error
110001	31	PCI Bus B Error
110010	32	Power Management Wakeup
111111	3f	RESERVED

1. This interrupt number is used in a system where the keyboard, mouse and serial interrupts are wire-ORed together.

2. These interrupt numbers are used in systems where the keyboard, mouse and serial interrupts are not wire-ORed together.

Each interrupt source also has a state register associated with it. This state register can be either of type “level” or of type “pulse.”

In the level sensitive case, the state register has two bits, and there are three valid states: IDLE, RECEIVED, and PENDING. IDLE represents the state where no interrupts are reported. RECEIVED indicates that an interrupt has been detected and should be delivered to the processor if the valid bit is set in its the mapping register. PENDING is the state when the interrupt has been delivered to the processor. Any subsequent detection of the same interrupt is ignored until software resets the state machine back to IDLE.

The state register for each level sensitive interrupts can be set to any desired state by software via the Clear Interrupt Registers.

In the pulse case, the state register consists of a single bit, with two states: IDLE and RECEIVED. These states have the same meaning as for the level sensitive case. There is no PENDING state, so the state machine transitions from RECEIVED back to IDLE when the interrupt is dispatched to a processor.

Diagnostic access is provided to allow software to read the state register for all interrupt sources.

See the hardware description of the Mondo Dispatch Unit if a more detailed description of interrupt handling is needed.

13.1.9.1 Partial Interrupt Mapping Registers

The offset of each partial Interrupt Mapping Register can be derived from the associated INO. There are two cases:

PCI Interrupts: $IMR\ offset = 0x0.0000.0C00 + (INO \& 0x3C) \ll 1$

OBIO Interrupts: $IMR\ offset = 0x0.0000.1000 + (INO \& 0x1F) \ll 3$

Table 13-45 Offset of Partial Interrupt Mapping Registers

Register	Offset	Access Size
PCI Bus A Slot 0 Int Mapping Reg	0x0.0000.0C00	8 bytes
PCI Bus A Slot 1 Int Mapping Reg	0x0.0000.0C08	8 bytes
PCI Bus B Slot 0 Int Mapping Reg	0x0.0000.0C20	8 bytes
PCI Bus B Slot 1 Int Mapping Reg	0x0.0000.0C28	8 bytes
PCI Bus B Slot2 Int Mapping Reg	0x0.0000.0C30	8 bytes
PCI Bus B Slot3 Int Mapping Reg	0x0.0000.0C38	8 bytes
SCSI Int Mapping Reg	0x0.0000.1000	8 bytes

Table 13-45 Offset of Partial Interrupt Mapping Registers (Continued)

Register	Offset	Access Size
Ethernet Int Mapping Reg	0x0.0000.1008	8 bytes
Parallel Port Int Mapping Reg	0x0.0000.1010	8 bytes
Audio Record Int Mapping Reg	0x0.0000.1018	8 bytes
Audio Playback Int Mapping Reg	0x0.0000.1020	8 bytes
Power Fail Int Mapping Reg	0x0.0000.1028	8 bytes
Kbd/mouse/serial Int Mapping Reg	0x0.0000.1030	8 bytes
Floppy Int Mapping Reg	0x0.0000.1038	8 bytes
Spare HW Int Mapping Reg	0x0.0000.1040	8 bytes
Keyboard Int Mapping Reg ¹	0x0.0000.1048	8 bytes
Mouse Int Mapping Reg ¹	0x0.0000.1050	8 bytes
Serial Int Mapping Reg ¹	0x0.0000.1058	8 bytes
Timer 0 Int Mapping Reg	0x0.0000.1060	8 bytes
Timer 1 Int Mapping Reg	0x0.0000.1068	8 bytes
UE Int Mapping Reg	0x0.0000.1070	8 bytes
CE Int Mapping Reg	0x0.0000.1078	8 bytes
PCI A Error Int Mapping Reg	0x0.0000.1080	8 bytes
PCI B Error Int Mapping Reg	0x0.0000.1088	8 bytes
Power Management Wakeup Int Mapping Reg	0x0.0000.1090	8 bytes

1. The keyboard, mouse, and serial interrupts are defined for future devices which do not combine all of the interrupts into one.

The format for each partial interrupt mapping register is shown in Table 13-46

Table 13-46 Format of Partial Interrupt Mapping Registers

Field	Bits	Description	Type
Reserved	63:32	Reserved, read as 0	R
V	31	Valid bit When set to 0, interrupt will not be dispatched to CPU. Has no other impact on interrupt state. Reset to 0	R/W
TID	30:26	Target ID UPA module ID of the processor that this interrupt will be sent to. Undefined at reset	R/W
Reserved	25:11	Reserved, read as 0.	R
IGN	10:6	Interrupt Group Number. This field always reflects the value of the IGN field in the U2P Control Register.	R
INO	5:0	Interrupt Number Offset The value of this field is hardwired for each mapping register, as shown in Table 13-44.	R

13.1.9.2 Full Interrupt Mapping Registers

There are only two full Interrupt Mapping Registers in U2P.

Table 13-47 Offset of Full Interrupt Mapping Registers

Register	Offset	Access Size
On board graphics Int Mapping Reg	0x0.0000.1098 and 0x0.0000.6000 ¹	8 bytes
Expansion UPA Int Mapping Reg	0x0.0000.10A0 and 0x0.0000.8000	8 bytes

1. Accesses to either of these addresses behave identically; in other words, the registers are double mapped.

The format for the full Interrupt Mapping Registers, shown in Table 13-48, is the same as the partial Interrupt Mapping Registers, except for the INR field.

Table 13-48 Format of Full Interrupt Mapping Registers

Field	Bits	Description	Type
Reserved	63:32	Reserved, read as 0.	R
V	31	Valid bit When set to 0, interrupt will not be dispatched to CPU. Has no other impact on interrupt state. Reset to 0	R/W
TID	30:26	Target ID UPA module ID of the processor that this interrupt will be sent to. Undefined at reset	R/W
Reserved	25:11	Reserved, read as 0.	R
INR	10:0	Interrupt Number Undefined at reset	R/W

13.1.9.3 Clear Interrupt Registers

The offset of each Clear Interrupt Register can be derived from the associated INO. There are two cases:

PCI Interrupts: CIR offset = $0x0.0000.1400 + (INO \& 0x1F) \ll 3$

OBIO Interrupts: CIR offset = $0x0.0000.1800 + (INO \& 0x1F) \ll 3$

The graphics and UPA expansion interrupts do not have associated Clear Interrupt Registers (they are pulse type interrupts which are automatically cleared when sent).

Table 13-49 Offset of Clear Interrupt Pseudo Registers

Register	Offset	Access Size
PCI Bus A Slot 0 Clear Int Regs	0x0.0000.1400 - 0x0.0000.1418	8 bytes
PCI Bus A Slot 1 Clear Int Regs	0x0.0000.1420 - 0x0.0000.1438	8 bytes
PCI Bus B Slot 0 Clear Int Regs	0x0.0000.1480 - 0x0.0000.1498	8 bytes

Table 13-49 Offset of Clear Interrupt Pseudo Registers (Continued)

Register	Offset	Access Size
PCI Bus B Slot 1 Clear Int Regs	0x0.0000.14A0 - 0x0.0000.14B8	8 bytes
PCI Bus B Slot 2 Clear Int Regs	0x0.0000.14C0 - 0x0.0000.14D8	8 bytes
PCI Bus B Slot 3 Clear Int Regs	0x0.0000.14E0 - 0x0.0000.14F8	8 bytes
SCSI Clear Int Reg	0x0.0000.1800	8 bytes
Ethernet Clear Int Reg	0x0.0000.1808	8 bytes
Parallel Port Clear Int Reg	0x0.0000.1810	8 bytes
Audio Record Clear Int Reg	0x0.0000.1818	8 bytes
Audio Playback Clear Int Reg	0x0.0000.1820	8 bytes
Power Fail Clear Int Reg	0x0.0000.1828	8 bytes
Kbd/mouse/serial Clear Int Reg	0x0.0000.1830	8 bytes
Floppy Clear Int Reg	0x0.0000.1838	8 bytes
Spare HW Clear Int Reg	0x0.0000.1840	8 bytes
Keyboard Clear Int Reg	0x0.0000.1848	8 bytes
Mouse Clear Int Reg	0x0.0000.1850	8 bytes
Serial Clear Int Reg	0x0.0000.1858	8 bytes
Timer 0 Clear Int Reg	0x0.0000.1860	8 bytes
Timer 1 Clear Int Reg	0x0.0000.1868	8 bytes
UE Clear Int Reg	0x0.0000.1870	8 bytes
CE Clear Int Reg	0x0.0000.1878	8 bytes
PCI A Async Error Clear Int Reg	0x0.0000.1880	8 bytes
PCI B Async Error Clear Int Reg	0x0.0000.1888	8 bytes
Power Management Wakeup Clear Int Reg	0x0.0000.1890	8 bytes

One such register exists per interrupt source. The lower 2 bits of the data word written to this register specify the operation as shown in the table below. All other bits should be written as 0 to guarantee future compatibility.

Table 13-50 Clear Interrupt Register

Field	Bits	Description	Type
RESERVED	63:02	Reserved, undefined when read.	R
STATE	01:00	State bits for the interrupt state machine associated with this interrupt. The following values may be written: 00 - Set state machine to IDLE state 01 - Set state machine to RECEIVED state 10 - Reserved 11 - Set state machine to PENDING state	W

Note – The Interrupt Clear Registers are write only. To determine the current interrupt state, use the interrupt state diagnostic registers instead.

13.1.9.4 Interrupt State Diagnostic Registers

Table 13-51 Offset of Interrupt State Diagnostic Registers

Register	Offset	Access Size	Type
PCI Int State Diag Reg	0x0.0000.A800	8 bytes	R
OBIO and Misc Int State Diag Reg	0x0.0000.A808	8 bytes	R

The meaning of the state bits and their layout are shown in the tables below.

The locations of each set of state bits can also be derived from the associated INO (except for Graphics and UPA expansion interrupts, for which the INO is fully programmable):

Register: if (INO & 0x20) then OBIO Int Diag Reg else PCI Int Diag Reg.

Bits: Int Diag Reg [((INO & 0x1F)<<1)+1: ((INO & 0x1F)<<1)].

The Graphics and UPA expansion interrupts are pulse type interrupts, and all others are level type interrupts.

Table 13-52 Level Interrupt State Meaning

Field	Description
INT_STATE<1:0>	00 - IDLE state; no interrupt received or pending 01 - RECEIVED state; interrupt detected, but not dispatched 11 - PENDING state; interrupt is received and dispatched 10 - Illegal state

Table 13-53 Pulse Interrupt State Meanings

Field	Description
INT_STATE<0>	0 - IDLE state; no interrupt received. 1 - RECEIVED state; interrupt detected, but not dispatched.

Definitions of the registers are shown in a general way in the table below. Refer to the formula above for specific bit positions. As an example, the bit position for PCI Bus B Slot 1, INTB# is <43:42>.

Table 13-54 PCI Int Diag Reg Definition

Bits	Description
7:0	PCI Bus A Slot 0 INT# DCBA
15:8	PCI Bus A Slot 1 INT# DCBA
31:16	Reserved
39:32	PCI Bus B Slot 0 INT# DCBA
47:40	PCI Bus B Slot 1 INT# DCBA
55:48	PCI Bus B Slot 2 INT# DCBA
63:56	PCI Bus B Slot 3 INT# DCBA

Table 13-55 OBIO and Misc Int Diag Reg Definition

Bits	Description
1:0	SCSI Int State
3:2	Ethernet Int State
5:4	Parallel Port Int State
7:6	Audio Record Int State
9:8	Audio Playback Int State
11:10	Power Fail Int State
13:12	Kbd/mouse/serial Int State
15:14	Floppy Int State
17:16	Spare HW Int State
19:18	Keyboard Int State
21:20	Mouse Int State
23:22	Serial Int State
25:24	Timer 0 Int State
27:26	Timer 1 Int State
29:28	UE Int State
31:30	CE Int State
33:32	PCI A Error Int State
35:34	PCI B Error Int State
37:36	Power Management Wakeup Int State
38	Graphics Int State
39	Expansion UPA Int State
63:40	Reserved (return 0 on read)

13.1.9.5 Interrupt Retry Timer Register

Table 13-56 Offset of Interrupt Retry Timer Registers

Register	Offset	Access Size
Interrupt Retry Reg	0x0.0000.1A00	8 bytes

If an interrupt packet sent by U2P is NACK'd by the UPA interrupt handler, U2P will wait for a certain number of clocks and resend the interrupt. This register controls the number of clocks the interrupt dispatch unit should wait before resending the interrupt packet. The count specified by this register is not precise: it is a free running counter which the logic samples. It must roll through 0 twice before the packet is retried.

Table 13-57 Interrupt Retry Timer Register

Field	Bits	Description	Type
RESERVED	63:20	Reserved, read as 0.	R
LIMIT	19:0	Limit - the retry interval	R/W

Note – The Retry timer provides maximum of 1M clocks of delay before re-issuing the interrupt to UPA. The maximum delay is approximately 31.5 msec. using the internal U2P clock for a reference source (15.7 msec per iteration through the counter with a worst case of nearly two complete cycles counting to 0). The minimum delay is (count + 1) clock cycles.

13.1.10 Counter/Timer Registers

Table 13-58 Offset of Counter/Timer Registers

Register	Offset	Access Size
Timer/Counter 0 Count Register	0x0.0000.1C00	8bytes
Timer/Counter 0 Limit Register	0x0.0000.1C08	8bytes
Timer/Counter 1 Count Register	0x0.0000.1C10	8bytes
Timer/Counter 1 Limit Register	0x0.0000.1C18	8bytes

13.1.10.1 Count Registers

Table 13-59 Count Register

Field	Bits	Description	Type
RESERVED	63:29	Reserved, read as zeros	R
COUNT	28:0	Value to preset counter on write, and current count value on read.	R/W

Each Count Register provides means to load the timer with a preset value on write, and return current value of timer on read. The count register normally increments once per microsecond, however, when the WAKEUP_EN bit is set in either PBM's CSR, Timer/Counter 0 increments once every millisecond instead (Timer/Counter 1 continues to increment every microsecond).

13.1.10.2 Limit Registers

Table 13-60 Limit Register

Field	Bits	Description	Type
Reserved	63:32	Reserved, read as 0.	R
INT_EN	31	Enable interrupt from this timer. Reset to '0' at power up	R/W
RELOAD	30	Writes to LIMIT register with this bit set causes the counter to restart at 0x0. Reads as '0'	W
PERIODIC	29	When set, causes counter to reset to 0x0 when LIMIT is reached.	R/W
LIMIT	28:0	Counter interrupt comparison value	R/W

Each Limit Register provides means to enable and disable the interrupt, reloading the counter, setting periodic interrupt, and setting LIMIT for counter time-out comparison.

13.1.11 Performance Monitor Registers

Table 13-61 Offset of Performance Monitor Registers

Register	Offset	Access Size
Performance Monitor Control Register	0x0.0000.0100	8 bytes
Performance Counter Register	0x0.0000.0108	8 bytes

In order to gather useful statistics on the performance of U2P, a pair of registers provide counts of key events. There are only two counters present, and the control register selects the input for each of the counters.

13.1.11.1 Performance Monitor Control Register

This register controls the events to be monitored by the Performance Counter Register. The event counters in the Performance Counter Register will be reset when the respective CLR{0,1} bits are written with a 1.

Table 13-62 Performance Monitor Control Register

Field	Bits	Description	Type
Reserved	63:16	Reserved, read as 0.	R
CLR1	15	Clears the counter indicated by SEL1	W
Reserved	14:13	Reserved, read as 0.	R
SEL1	12:8	Select event source for counter 1. Selected source counter is cleared when CLR1 field is written.	R/W
CLR0	7	Clears the counter indicated by SEL0	W
Reserved	6:5	Reserved, read as 0.	R
SEL0	4:0	Select event source for counter 0. Selected source counter is cleared when CLR0 field is written.	R/W

The table below defines the code to select monitored events in U2P.

Table 13-63 Performance Counter Event Sources

SEL0, SEL1	Event Sources
0x00	Number of streaming DVMA read transfers for PCI bus A
0x01	Number of streaming DVMA write transfers for PCI bus A
0x02	Number of consistent DVMA read transfers for PCI bus A
0x03	Number of consistent DVMA write transfers for PCI bus A
0x04	Number of streaming buffer misses for PCI bus A
0x05	Number of cycles PCI bus A is granted to DVMA ¹
0x06	Number of words transferred using DVMA on PCI bus A ²
0x07	Number of U2P cycles PCI bus A is consumed by PIO ¹
0x08	Number of streaming DVMA read transfers for PCI bus B
0x09	Number of streaming DVMA write transfers for PCI bus B
0x0A	Number of consistent DVMA read transfers for PCI bus B

Table 13-63 Performance Counter Event Sources (Continued)

SEL0, SEL1	Event Sources
0x0B	Number of consistent DVMA write transfers for PCI bus B
0x0C	Number of streaming buffer misses for PCI bus B
0x0D	Number of cycles PCI bus B is granted to DVMA ¹
0x0E	Number of words transferred using DVMA on PCI bus B ²
0x0F	Number of U2P cycles PCI bus B is consumed by PIO ¹
0x10	Number of TLB misses
0x11	Number of interrupts
0x12	Number of interrupt NACK on UPA
0x13	Number of PIO read transfers
0x14	Number of PIO write transfers
0x15	Number of merge buffer transactions
0x16	Number of PCI DMA requests retried on bus A due to tablewalks
0x17	Number of PCI DMA requests retried on bus A due to STC
0x18	Number of PCI DMA requests retried on bus B due to tablewalks
0x19	Number of PCI DMA requests retried on bus B due to STC
0x1A-0x1F	Reserved. Counter value is undefined when these sources are chosen

1. This is the number of internal clock cycles, which may be twice the number of PCI clock cycles on bus A, and will be twice the number of PCI clock cycles on bus B.
2. The word count will increment whenever any of the four associated byte enables is active. If, during the recording interval, there are any DMA's that start or end on unaligned addresses, it won't be possible to determine the exact number of bytes transferred. In addition, the word count will increment twice for every data transfer on a 33MHz PCI bus, so the count should be scaled down before using.

13.1.11.2 Performance Counter Register

This is a 64-bit read-only register. Value read back contains the counts of two events selected by Performance Monitor Control Register. The two counters operate independently. When the counter reaches its maximum count, it will wrap around to 0x0 and continues counting. Software needs to detect and handle the overflow condition.

Table 13-64 Performance Counter Register

Field	Bits	Description	Type
CNT0<31:0>	63:32	Contains value for event counter 0	R
CNT1<31:0>	31:00	Contains value for event counter 1	R

13.2 PCI Address Spaces

13.2.1 UPA to PCI

Several regions of U2P's UPA address space are used to access devices on the two PCI busses supported by U2P. Most UPA transactions to these regions (exceptions listed below) are forwarded to the appropriate bus segment, according to the address map below. For the non-block transfers, any legal combination of bits in the bytemask may be set (i.e. arbitrary bytemasks for writes, aligned 1, 2, 4, 8 or 16 byte bytemasks for reads), within the size restrictions listed below. The PCI byte enables generated by U2P for the transaction will match the UPA bytemask. The value of the BOOT_BUS input pin affects the address map as noted in the table.

Table 13-65 Offsets for access from UPA space to PCI space

PCI Address Space	UPA Offset	UPA Commands Supported	PCI Commands Generated
PCI Configuration Space	0x0.0100.0000-0x0.01FF.FFFF	P_NCRD_REQ (max 4 bytes) P_NCWR_REQ (max 4 bytes)	Configuration Read Configuration Write (may also be Special Cycle)
PCI Bus A I/O Space	0x0.0200.0000-0x0.0200.FFFF	P_NCRD_REQ (max 4 bytes) P_NCWR_REQ (max 4 bytes)	I/O Read I/O Write

Table 13-65 Offsets for access from UPA space to PCI space (Continued)

PCI Address Space	UPA Offset	UPA Commands Supported	PCI Commands Generated
PCI Bus B I/O Space	0x0.0201.0000-0x0.0201.FFFF	P_NCRD_REQ (max 4 bytes) P_NCWR_REQ (max 4 bytes)	I/O Read I/O Write
PCI Bus A Memory Space (if BOOT_BUS=1, else PCI Bus B Memory Space)	0x1.0000.0000-0x1.7FFF.FFFF	P_NCRD_REQ P_NCBRD_REQ P_NCWR_REQ P_NCBWR_REQ	Memory Read Memory Read Line Memory Write Memory Write
PCI Bus B Memory Space (if BOOT_BUS=1, else PCI Bus A Memory Space)	0x1.8000.0000-0x1.FFFF.FFFF	P_NCRD_REQ P_NCBRD_REQ P_NCWR_REQ P_NCBWR_REQ	Memory Read Memory Read Line Memory Write Memory Write

Note – All PCI address spaces use little-endian address byte ordering. Any accesses made to a PCI address space should use one of the SPARC V9 little-endian support mechanisms to get proper byte ordering. These mechanisms include little-endian ASI's or MMU support for marking pages little-endian.

13.2.1.1 PCI Configuration Space

PCI configuration cycles are generated by U2P in response to UPA reads and writes to addresses in the PCI Configuration Space. The PCI Specification defines two mechanisms for generating PCI configuration cycles, one of which is required to be implemented for PC compatible systems; U2P, however, does not implement either of those mechanisms. Instead, the following mechanism is used, which allows for generation of both Type 0 and Type 1 configuration cycles. Type 0 configuration cycles are used to configure devices on a PCI bus directly beneath this bridge. Type 1 configuration cycles are used to configure devices on subordinate PCI busses via other bridges beneath this one.

A type 0 configuration cycle on a PCI bus is initiated by a host access to U2P where address bits 32:24 equal 0x001 and bits 23:16 match the Bus Number register in the bridge configuration header for one of the PBM blocks, and the Device Number is not 0 (a Device Number of 0 designates the PBM itself, and the configuration cycle will not appear on the PCI bus). The type 0 configuration cycle will be generated on the corresponding PCI bus. Figure 13-3 shows how address bits 15:0 map to the PCI configuration cycle address. Bits 10:0 come directly from the configuration space address, and bits 30:11 are decoded from the Device Number field starting with device number 0 (device number 0 is always used for the PBM itself). Bit 31 is always 0 for a type 0 configuration cycle. PCI Bus B on U2P has no IDSEL# pins so

32	24 23	16 15	11 10	8 7	2 1 0
0 0 0 0 0 0 0 1	Bus Number	Device Number	Function Number	Register Number	0 0

Configuration Space Address

31 30	11 10	8 7	2 1 0
0	² Device Number (Only one '1')	Function Number	Register Number 0 0

PCI Configuration Cycle Address

Figure 13-3 Type 0 Configuration Address Mapping

device IDSEL# lines must be resistively tied to individual AD[30:12] lines. It is recommended that slot 0 be device 1, tied to AD[12]; slot 1 be device 2; tied to AD[13], etc.

A type 1 configuration cycle is generated when the bus number field of the configuration space address is greater than the Bus Number configuration register value and less than or equal to the Subordinate Bus Number register for one of the PBM blocks. Bus numbers that are outside of the Bus Number - Subordinate Bus Number range for both PBM blocks will not generate a configuration cycle on either bus. The type 1 configuration cycle address is constructed from the configuration space address as shown in Figure 13-3.

32	24 23	16 15	11 10	8 7	2 1 0
0 0 0 0 0 0 0 1	Bus Number	Device Number	Function Number	Register Number	0 0

Configuration Space Address

31	24 23	16 15	11 10	8 7	2 1 0
Reserved	Bus Number	Device Number	Function Number	Register Number	0 1

PCI Configuration Cycle Address

Figure 13-4 Type 1 Configuration Address Mapping

Note – It is up to software to ensure that the Bus Number and Subordinate Bus Number registers of the two PBM blocks are correctly programmed so that configuration accesses are not passed to both PCI busses. U2P will detect such duplicate bus ranges, and pass the configuration cycle only to bus A.

13.2.1.2 Special Cycles

The generation of special cycles on a PCI bus is just a special case of the type 0 configuration cycle, where the Device Number and Function Number portions of the address are all 1's and the Register Number is all 0's.

13.2.1.3 PCI I/O Space

PCI I/O cycles are generated by U2P in response to UPA reads and writes to addresses in one of the PCI I/O Spaces (one for each bus). For each access to I/O space, an I/O Read or I/O Write command is issued on the appropriate PCI bus. Bits 31:16 of the address on the PCI bus will be 0, and bits 15:0 will be a copy of UPA address bits 15:0.

Note – It is expected that all PCI resources will be mapped by software into PCI Memory space, and not PCI I/O space. Access to PCI I/O space is only provided to allow for support of non-compliant PCI devices.

13.2.1.4 PCI Memory Space

PCI Memory cycles are generated by U2P in response to UPA reads and writes to addresses in one of the PCI Memory Spaces (one for each bus). As a bus master, U2P will never generate Dual-Address-Cycles; all PCI addresses generated will be 32 bits. Bits 30:0 of the PCI address will be a copy of bits 30:0 of the UPA address, and bit 31 of the PCI address will always be 0. The memory command used for the PCI transaction depends on the UPA transaction type, as shown in Table 13-65.

For PCI transactions with multiple data phases, U2P will always use Linear Incrementing mode as defined by the PCI specification. Cache Line Toggle Mode is not used.

Note – Because of the way the addressing is done, it is not possible for U2P to generate an address in the range 0x8000.0000-0xFFFF.FFFF on either PCI bus. Software should ensure that PCI targets on each bus are mapped into the correct range so that they are accessible.

13.2.2 PCI to UPA

13.2.2.1 PCI Configuration Space

U2P does not respond to any Configuration Read or Configuration Write cycles on either PCI bus. U2P is the central resource for each PCI bus, and is expected to be the only device generating configuration cycles. Accesses from the UPA bus that target configuration registers within either of the PBM blocks will be serviced by the PBM block without generating a configuration cycle on the PCI bus.

Peer-to-peer transfers between two PCI devices on the same bus using Configuration Read or Configuration Write commands aren't (and can't be) prohibited by U2P, but are not expected to occur, since U2P is the only device that knows the correct method for driving the IDSEL# lines.

13.2.2.2 PCI I/O Space

U2P does not respond to I/O Read or I/O Write commands on the PCI bus.

Peer-to-peer transfers between two PCI devices on the same bus using I/O Read or I/O Write commands aren't (and can't be) prohibited by U2P, but they are not expected to occur, since all PCI resources are intended to be mapped into Memory Space.

13.2.2.3 PCI Memory Space

This is the space in which DVMA, DMA (IOMMU bypass), and PCI peer-to-peer activity takes place. The final destination and address translation of a PCI Memory transaction is based on:

- Addressing mode used: 64-bit (DAC) vs. 32-bit (SAC).
- PCI address bit <31>.
- Value of MMU_EN in the IOMMU Control Register.
- Value of PCI address bits <63:50> in DAC mode.

Table 13-66 shows the various ways that U2P as a PCI target device deals with PCI addresses.

Table 13-66 PCI DVMA Modes of Operation

Mode	Addr<31>	MMU_EN	Addr<63:50>	Result
SAC	0	X	N/A	PCI peer-to-peer (Ignored by U2P)
SAC	1	0	N/A	Pass-through
SAC	1	1	N/A	IOMMU Translation (DVMA)
DAC	X	X	0x0000-0x3FFE	Ignored by U2P
DAC	X	X	0x3FFF	Bypass (DMA)

Pass-through

In pass-through mode, UPA_Addr<40:31> = 0x000, UPA_Addr<30:0> = PCI_Addr<30:0>. Pass-through transfers always generate cacheable transactions.

IOMMU Translation mode

In IOMMU translation mode, the physical address is obtained by performing a virtual to physical translation through the IOMMU. The value of the C bit in the TTE for the virtual page determines whether the UPA transaction generated is cacheable or non-cacheable.

PCI peer-to-peer mode

In peer-to-peer mode, two devices on the same PCI bus transfer data without any involvement from U2P. There is no address translation involved - the master device simply puts out the PCI address to which the target device has been mapped. If no device has been mapped there, the PCI master device will terminate its cycle with a Master-Abort.

Bypass mode

In bypass mode, the UPA_Addr<40:0> = PCI_Addr<40:0>. The decision to generate a cacheable vs. non-cacheable transaction is determined by the value of PCI_Addr<40>, with a 0 specifying cacheable.

In all cases, U2P will only support bursts as a target device in Linear Incrementing mode. If any of the reserved modes are used, U2P will issue a target disconnect after the first data phase.

13.3 Address Map Summary

Table 13-67 Address Map Summary

Offset	Register	Access Size
0x0.0000.0000	UPA Port ID Register	8 bytes
0x0.0000.0008	UPA Configuration Reg	8 bytes
0x0.0000.0010	U2P Control Register	8 bytes
0x0.0000.0020	ECC Control Register	8 bytes
0x0.0000.0030	UE AFSR	8 bytes
0x0.0000.0038	UE AFAR	8 bytes
0x0.0000.0040	CE AFSR	8 bytes
0x0.0000.0048	CE AFAR	8 bytes
0x0.0000.0100	Performance Monitor Control Register	8 bytes
0x0.0000.0108	Performance Counter Register	8 bytes
0x0.0000.0200	IOMMU Control Register	8 bytes
0x0.0000.0208	TSB Base Address Reg	8 bytes
0x0.0000.0210	IOMMU Flush Register	8 bytes
0x0.0000.0C00	PCI Bus A Slot 0 Int Mapping Reg	8 bytes
0x0.0000.0C08	PCI Bus A Slot 1 Int Mapping Reg	8 bytes
0x0.0000.0C20	PCI Bus B Slot 0 Int Mapping Reg	8 bytes
0x0.0000.0C28	PCI Bus B Slot 1 Int Mapping Reg	8 bytes
0x0.0000.0C30	PCI Bus B Slot 2 Int Mapping Reg	8 bytes
0x0.0000.0C38	PCI Bus B Slot 3 Int Mapping Reg	8 bytes
0x0.0000.1000	SCSI Int Mapping Reg	8 bytes
0x0.0000.1008	Ethernet Int Mapping Reg	8 bytes
0x0.0000.1010	Parallel Port Int Mapping Reg	8 bytes
0x0.0000.1018	Audio Record Int Mapping Reg	8 bytes
0x0.0000.1020	Audio Playback Int Mapping Reg	8 bytes
0x0.0000.1028	Power Fail Int Mapping Reg	8 bytes
0x0.0000.1030	Kbd/mouse/serial Int Mapping Reg	8 bytes

Table 13-67 Address Map Summary (Continued)

Offset	Register	Access Size
0x0.0000.1038	Floppy Int Mapping Reg	8 bytes
0x0.0000.1040	Spare HW Int Mapping Reg	8 bytes
0x0.0000.1048	Keyboard Int Mapping Reg	8 bytes
0x0.0000.1050	Mouse Int Mapping Reg	8 bytes
0x0.0000.1058	Serial Int Mapping Reg	8 bytes
0x0.0000.1060	Timer 0 Int Mapping Reg	8 bytes
0x0.0000.1068	Timer 1 Int Mapping Reg	8 bytes
0x0.0000.1070	UE Int Mapping Reg	8 bytes
0x0.0000.1078	CE Int Mapping Reg	8 bytes
0x0.0000.1080	PCI A Error Int Mapping Reg	8 bytes
0x0.0000.1088	PCI B Error Int Mapping Reg	8 bytes
0x0.0000.1090	Power Management Wakeup Int Mapping Reg	8 bytes
0x0.0000.1098	On board graphics Int Mapping Reg (also mapped at 0x0.0000.6000)	8 bytes
0x0.0000.10A0	Expansion UPA Int Mapping Reg (also mapped at 0x0.0000.8000)	8 bytes
0x0.0000.1400- 0x0.0000.1418	PCI Bus A Slot 0 Clear Int Regs	8 bytes
0x0.0000.1420- 0x0.0000.1438	PCI Bus A Slot 1 Clear Int Regs	8 bytes
0x0.0000.1480- 0x0.0000.1498	PCI Bus B Slot 0 Clear Int Regs	8 bytes
0x0.0000.14A0- 0x0.0000.14B8	PCI Bus B Slot 1 Clear Int Regs	8 bytes
0x0.0000.14C0- 0x0.0000.14D8	PCI Bus B Slot 2 Clear Int Regs	8 bytes
0x0.0000.14E0- 0x0.0000.14F8	PCI Bus B Slot 3 Clear Int Regs	8 bytes
0x0.0000.1800	SCSI Clear Int Reg	8 bytes
0x0.0000.1808	Ethernet Clear Int Reg	8 bytes
0x0.0000.1810	Parallel Port Clear Int Reg	8 bytes
0x0.0000.1818	Audio Record Clear Int Reg	8 bytes
0x0.0000.1820	Audio Playback Clear Int Reg	8 bytes

Table 13-67 Address Map Summary (Continued)

Offset	Register	Access Size
0x0.0000.1828	Power Fail Clear Int Reg	8 bytes
0x0.0000.1830	Kbd/mouse/serial Clear Int Reg	8 bytes
0x0.0000.1838	Floppy Clear Int Reg	8 bytes
0x0.0000.1840	Spare HW Clear Int Reg	8 bytes
0x0.0000.1848	Keyboard Clear Int Reg	8 bytes
0x0.0000.1850	Mouse Clear Int Reg	8 bytes
0x0.0000.1858	Serial Clear Int Reg	8 bytes
0x0.0000.1860	Timer 0 Clear Int Reg	8 bytes
0x0.0000.1868	Timer 1 Clear Int Reg	8 bytes
0x0.0000.1870	UE Clear Int Reg	8 bytes
0x0.0000.1878	CE Clear Int Reg	8 bytes
0x0.0000.1880	PCI A Async Error Clear Int Reg	8 bytes
0x0.0000.1888	PCI B Async Error Clear Int Reg	8 bytes
0x0.0000.1890	Power Management Wakeup Clear Int Reg	8 bytes
0x0.0000.1A00	Interrupt Retry Register	8 bytes
0x0.0000.1C00	Timer/Counter 0 Count Register	8 bytes
0x0.0000.1C08	Timer/Counter 0 Limit Register	8 bytes
0x0.0000.1C10	Timer/Counter 1 Count Register	8 bytes
0x0.0000.1C18	Timer/Counter 1 Limit Register	8 bytes
0x0.0000.2000	PCI Bus A Control/Status Register	8 bytes
0x0.0000.2010	PCI Bus A AFSR	8 bytes
0x0.0000.2018	PCI Bus A AFAR	8 bytes
0x0.0000.2020	PCI Bus A Diagnostic Register	8 bytes
0x0.0000.2800	Streaming Buffer A Control Reg.	8 bytes
0x0.0000.2808	Streaming Buffer A Page Flush/Invalidate Reg	8 bytes
0x0.0000.2810	Streaming Buffer A Flush Synchronization Reg	8 bytes
0x0.0000.4000	PCI Bus B Control/Status Register	8 bytes
0x0.0000.4010	PCI Bus B AFSR	8 bytes
0x0.0000.4018	PCI Bus B AFAR	8 bytes
0x0.0000.4020	PCI Bus B Diagnostic Register	8 bytes

Table 13-67 Address Map Summary (Continued)

Offset	Register	Access Size
0x0.0000.4800	Streaming Buffer B Control Reg	8 bytes
0x0.0000.4808	Streaming Buffer B Page Flush/Invalidate Reg	8 bytes
0x0.0000.4810	Streaming Buffer B Flush Synchronization Reg	8 bytes
0x0.0000.6000	On board graphics Int Mapping Reg (also mapped at 0x0.0000.1098)	8bytes
0x0.0000.8000	Expansion UPA Int Mapping Reg (also mapped at 0x0.0000.10A0)	8bytes
0x0.0000.A000	DMA Scoreboard Diag Reg 0	8 bytes
0x0.0000.A008	DMA Scoreboard Diag Reg 1	8 bytes
0x0.0000.A400	IOMMU Virtual Address Diag Reg	8 bytes
0x0.0000.A408	TLB Tag Compare Diag	8 bytes
0x0.0000.A500- 0x0.0000.A57F	IOMMU LRU Queue Diag	8 bytes
0x0.0000.A580- 0x0.0000.A5FF	TLB Tag Diag	8 bytes
0x0.0000.A600- 0x0.0000.A67F	TLB Data RAM Diag	8 bytes
0x0.0000.A800	PCI Int State Diag Reg	8 bytes
0x0.0000.A808	OBIO and Misc Int State Diag Reg	8 bytes
0x0.0000.B000- 0x0.0000.B3FF	Streaming Buffer A Data RAM Diagnostic	8 bytes
0x0.0000.B400- 0x0.0000.B7FF	Streaming Buffer A Error Status Diagnostics	8 bytes
0x0.0000.B800- 0x0.0000.B87F	Streaming Buffer A Tag Diagnostics	8 bytes
0x0.0000.B900- 0x0.0000.B97F	Streaming Buffer A Line Tag Diagnostics	8 bytes
0x0.0000.C000- 0x0.0000.C3FF	Streaming Buffer B Data RAM Diagnostic	8 bytes
0x0.0000.C400- 0x0.0000.C7FF	Streaming Buffer B Error Status Diagnostics	8 bytes
0x0.0000.C800- 0x0.0000.C87F	Streaming Buffer B Page Tag Diagnostics	8 bytes
0x0.0000.C900- 0x0.0000.C97F	Streaming Buffer B Line Tag Diagnostics	8 bytes

Table 13-67 Address Map Summary (Continued)

Offset	Register	Access Size
0x0.0100.0000-0x0.01FF.FFFF	PCI Configuration Space	1-4 bytes
0x0.0100.0000-0x0.0100.00FF	PBM B PCI Configuration Header (Location after reset, may be moved by SW)	1-4 bytes
0x0.0101.0000-0x0.0101.00FF	PBM A PCI Configuration Header (Location after reset, may be moved by SW)	1-4 bytes
0x0.0200.0000-0x0.0200.FFFF	PCI Bus A I/O Space	1-4 bytes
0x0.0201.0000-0x0.0201.FFFF	PCI Bus B I/O Space	1-4 bytes
0x1.0000.0000-0x1.7FFF.FFFF	If BOOT_BUS=1, PCI Bus A Memory Space	Any
0x1.0000.0000-0x1.7FFF.FFFF	If BOOT_BUS=0, PCI Bus B Memory Space	Any
0x1.8000.0000-0x1.FFFF.FFFF	If BOOT_BUS=1, PCI Bus B Memory Space	Any
0x1.8000.0000-0x1.FFFF.FFFF	If BOOT_BUS=0, PCI Bus A Memory Space	Any
All others	Reserved	None

