



EUROPEAN SOUTHERN OBSERVATORY

Organisation Européenne pour des Recherches Astronomiques dans l'Hémisphère Austral
Europäische Organisation für astronomische Forschung in der südlichen Hemisphäre

ESO - European Southern Observatory
Karl-Schwarzschild Str. 2, D-85748 Garching bei München

Very Large Telescope

HAWK-I User Manual

Doc. No. VLT-MAN-ESO-14800-3486

Issue 81
06 December 2007

Prepared M. Kissler-Patig, N. Ageorges

Change Record

Issue/Rev.	Date	Section/Parag. affected	Reason/Initiation/Documents/Remarks
Issue 1 Issue 81	25 May 2007 31 August 2007 6 Dec. 2007	all all	First release for PAE prepared for CfP P81 update after end of commissionings

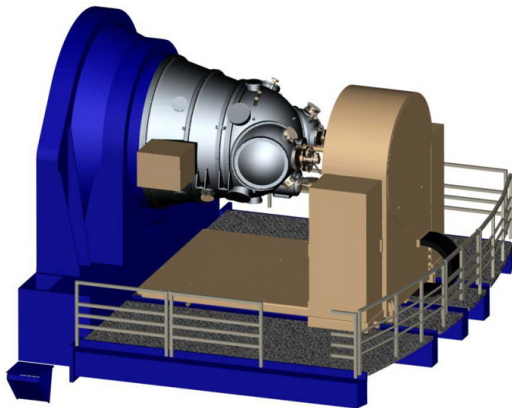

HAWK-I as a CAD drawing attached to the VLT and in the integration hall in Garching

HAWK-I in a Nutshell

Online information on HAWK-I can be found on the [instrument web pages](#).

HAWK-I is a near-infrared ($0.85 - 2.5 \mu\text{m}$) wide-field imager.

The instrument is cryogenic (120 K, detectors at 80 K) and has a full reflective design. The light passes four mirrors and two filter wheels before hitting a mosaic of four Hawaii 2RG 2048×2048 pixels detectors. The final F-ratio is F/4.36 ($1''$ on the sky correspond to $169.4 \mu\text{m}$).

The field of view on the sky is $7.5' \times 7.5'$ (with a small cross-shaped gap of $\sim 15''$ between the four detectors). The pixel scale is $0.106''/\text{pix}$. The two filter wheels of six positions each host ten filters: Y(Z), J, H, K_s (identical to the [VISTA](#) filters), as well as 6 narrow band filters ($\text{Br}\gamma$, CH4, H2 and three cosmological filters at 1.061, 1.187, and $2.090 \mu\text{m}$).

Typical limiting magnitudes ($S/N=5$ in 3600s on source) are around $J=23.9$ and $K_s=22.3$ mag (Vega).

Contents

1	Introduction	1
1.1	Scope of this document	1
1.2	Structure of this document	1
1.3	Glossary	1
1.4	Abbreviations and Acronyms	1
I	Observing with HAWK-I: from phase 1 to data reduction	2
2	PHASE 1: applying for observing time with HAWK-I	2
2.1	Is HAWK-I the right instrument for your project?	2
2.1.1	Field of View	2
2.1.2	Filters	3
2.1.3	Limiting magnitudes	3
2.1.4	Instrument's performance	3
2.2	Photometry with HAWK-I	4
2.2.1	Two ways to get reasonable photometry	4
2.2.2	Consider the 2MASS calibration fields	5
2.3	The Exposure Time Calculator	5
2.4	Proposal Form	6
2.5	Overheads and Calibration Plan	6
3	PHASE 2: Preparing your HAWK-I observations	7
3.1	HAWK-I specifics to templates, OBs, and p2pp	7
3.1.1	p2pp	7
3.1.2	Observing Blocks – OBs	7
3.1.3	Templates	7
3.2	Finding Charts and README Files	8
4	Observing (Strategies) with HAWK-I	9
4.1	Overview	9
4.2	Visitor Mode Operations	9
4.3	The influence of the Moon	9
4.4	Orientation, offset conventions and definitions	9
4.5	Instrument and telescope overheads	11
4.6	Recommended DIT/NDIT and Object–Sky pattern	11
II	Reference Material	13
A	The HAWK-I filters	13

B The HAWK-I detectors	16
B.1 Detectors' structures	16
C The HAWK-I Field-of-View	19
C.1 Relative position of the four quadrants	19
C.1.1 Center of Rotation and Centre of Pointing	19
C.2 Vignetting of the field-of-view	20
D The HAWK-I calibration plan	21
D.1 Do you need special calibrations?	21
D.2 The HAWK-I standard calibrations in a nutshell	21
D.3 Quality Control	21
E The HAWK-I pipeline	23

1 Introduction

1.1 Scope of this document

The HAWK-I user manual provides the information required for the proposal preparation (phase 1), the phase 2 observation preparation and the observation phase.

The instrument has just completed its commissioning phase and is being used for science verification until the regular start of operations in period 81. We welcome any comments and suggestions on the manual; these should be addressed to our user support group at usd-help@eso.org.

1.2 Structure of this document

The document is structured in 2 parts. Part 1 (I) takes you step by step through the essentials (writing your proposal in phase 1, preparing your observations in phase 2, conducting your observations at the telescope and reducing your data). Part 2 (II) contains collected useful reference material.

1.3 Glossary

1.4 Abbreviations and Acronyms

DMO	Data Management and Operations Division
ESO	European Southern Observatory
ETC	Exposure Time Calculator
FC	Finding Chart
FoV	Field of View
FWHM	Full Width at Half Maximum
HAWK-I	High Acuity Wide-field K-band Imager
NIR	Near InfraRed
OB	Observing Block
P2PP	Phase II Proposal Preparation
PSF	Point Spread Function
QC	Quality Control
RTC	Real Time Computer
RTD	Real Time Display
SM	Service Mode
TIO	Telescope and Instrument Operator
USD	User Support Department
VLT	Very Large Telescope
VM	Visitor Mode

Part I

Observing with HAWK-I: from phase 1 to data reduction

2 PHASE 1: applying for observing time with HAWK-I

This section will help you to decide whether HAWK-I is the right instrument for your scientific project, take you through a quick evaluation of the observing time needed, and guide you through the particularities of HAWK-I in the proposal form.

2.1 Is HAWK-I the right instrument for your project?

HAWK-I does only one thing but does it well: direct imaging in the NIR (0.97 to 2.31 μm) over a large field (7.5' \times 7.5'). If this is what you intend to do, HAWK-I is the instrument you need. If not, you have probably downloaded the wrong manual...

The basic characteristics (FoV, pixel scale, ...) can be found in the nutshell at the beginning of this document.

2.1.1 Field of View

The Field of View of HAWK-I is defined by four Hawaii-2RG chips of 2048² pixels each (1 pixel corresponds to 0.106 arcsec on the sky). The detectors are separated by gaps of about 15 arcsec. Thus, the field of view looks like this:

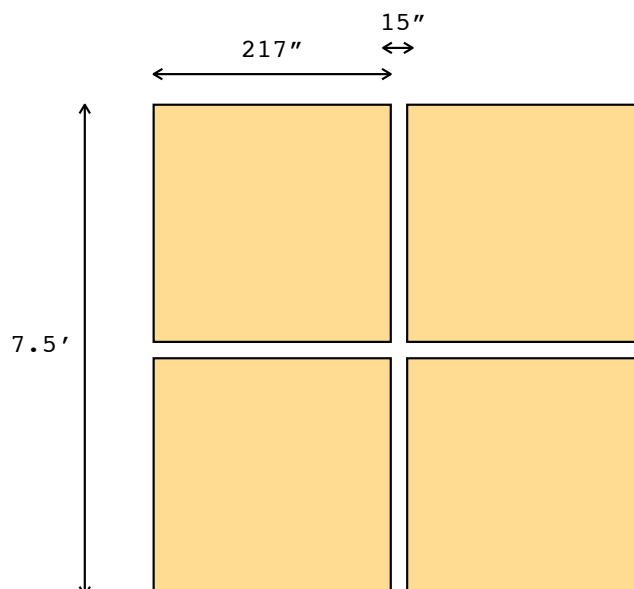

Note that it is very tempting to point *right onto* your favourite target and to lose it in the gap, since this is where the telescope points.

BEWARE of the gap between the detectors! And see the details in Appendix C.

2.1.2 Filters

HAWK-I is equipped with 10 filters: 4 broad band filters, and 6 narrow band filters. (see A for detailed characteristics and the URL to download the filter curves in electronic form).

The broad-band filters are the classical NIR filters: Y,J,H,K. The particularity of HAWK-I is that the broad band filter set has been ordered together with the ones of VISTA. There are thus *identical* which allows easy cross-calibrations and comparisons.

The narrow band filters include 3 cosmological filters (for Ly α at z of 7.7 ($1.06\mu\text{m}$) and 8.7 ($1.19\mu\text{m}$), and H α at $z = 2.2$, i.e. $2.09\mu\text{m}$) as well as 3 stellar filters (CH $_4$, H $_2$, Br γ).

Can you bring your own filters? Possibly.

HAWK-I hosts large (105mm^2 , i.e. expensive) filters, and was designed to have an easy access to the filter wheel. However, to exchange filters the instrument needs to be warmed up which, usually, only happens once per year.

Thus, in exceptionnal cases, i.e. for very particular scientific program, user supplied filters can be installed in HAWK-I, within the operational constraints of the observatory. Please make sure to contact paranal@eso.org before buying your filters. provide your filters, we would do our best to support you (within the operational constraints of the observatory).

2.1.3 Limiting magnitudes

Limiting magnitudes are of course very much dependent on the observing conditions. The [exposure time calculator](#) is reasonably well calibrated and we encourage you to use it.

In order to give you a rough idea of the performance to be expected, we list here the limiting magnitudes (S/N=5 for a point source in 3600s integration on source) under average conditions (0.8" seeing, 1.2 airmass):

Filter	Limiting mag [Vega]	Limiting mag [AB]	Saturation limit (in 2 sec)*
J	23.9	24.8	11.0
H	22.5	23.9	11.3
K _s	22.3	24.2	10.2

*: assumed 0.8" seeing.

For more detailed exposure time calculation, in particular for narrow band filters, please use the [exposure time calculator](#).

Due to persistence effect of the detector, in service mode, no observation will be accepted for fields containing objects brighter than K_s=8.6 , H=9.6 & J=9.3 ; i.e. ~ 5 times the saturation level.

2.1.4 Instrument's performance

We expect HAWK-I to be used for plain imaging, photometry and astrometry.

The image quality of HAWK-I is excellent across the entire field of view. Distortions are below 2% over the full 10' diagonal and the image quality has always been limited by the seeing (our best

recorded images had FWHM below 2.2 pix, i.e. $<0.23''$ in the Ks band).

The photometric accuracy and homogeneity that we measured across one quadrant is $<5\%$ (as monitored on 2MASS calibration fields). We expect that with an even more careful illumination correction and flat-fielding about 3% absolute accuracy across the entire field will be achieved routinely when the calibration database is filled and stable.

Of course, differential photometry can be pushed to a higher accuracy. Note in particular, that given the HAWK-I field size, between 10 and 100 useful 2MASS stars (calibrated to 0.05 – 0.10 mag) are usually present in the field.

Finally, the relative astrometry across the entire field was auto-calibrated (following Anderson et al. 2006, A&A 454, 1029) and checked against ACS astrometric fields. The distortion map currently allows to recover relative position across the entire field with a (spectacular) precision of <5 mas.

A note of caution: as all current infrared arrays, the HAWK-I detectors suffer of persistence at the level of $10^{-3} - 10^{-4}$ (depending on how badly the pixels were saturated) that decays slowly over minutes (about 5min for the maximum tolerated saturation level in SM). This might leave artefacts reflecting the dither pattern around saturated stars.

2.2 Photometry with HAWK-I

As you will have noticed, acquiring a single star per night does not allow to carry out high precision photometry (but rather to monitor the instrument performance).

2.2.1 Two ways to get reasonable photometry

If good photometry is your goal, you should go for one of the following options.

- **Ask for special calibrations!** Take into account as early as phase 1 (i.e. in your proposal) the fact that you want to observe more and other standard fields than the ones foreseen in the calibration plan.

In your README file you can then explain that you want your specified standard field observed e.g. before and after your science OB.

You can also specify that you want illumination maps for your filters close in time to your observations, and/or specify as special calibrations your own illumination maps.

- If a photometric calibration to $\sim 0.05-0.1$ magnitude is enough for your programme, consider that the HAWK-I field is large and that (by experience) you will have 10–100 stars from the 2MASS catalogue in your field.

These are typically catalogued with a photometry good to <0.1 mag and would allow to determine the zero point on your image to ~ 0.05 mag, using these "local secondary standards". Extinction coefficients would automatically be taken into account (and the colour terms for HAWK-I are small, $\sim 0.1 \times (J-K)$).

Check with Skycat (or Gaia) ahead of time whether good (non-saturated!) 2MASS stars are present in your science field.

Skycat is available under <http://archive.eso.org/skycat/>

Gaia is part of the starlink project: <http://starlink.jach.hawaii.edu/>

2.2.2 Consider the 2MASS calibration fields

The 2MASS mission used a number of calibration fields for the survey. Details are given at http://www.ipac.caltech.edu/2mass/releases/allsky/doc/seca4_1.html
In particular the sect.III, 2 http://www.ipac.caltech.edu/2mass/releases/allsky/doc/sec3_2d.html provides a list of fields that **you could use** as photometric fields in order to calibrate your observations.

2.3 The Exposure Time Calculator

The HAWK-I exposure time calculator can be found at:

<http://www.eso.org/observing/etc>

it returns a good estimation of the integration time (on source!) needed in order to achieve a given S/N, as a function of atmospheric conditions.

A few words about various *input variables* that might not be quite standard (also read the online help provided on the ETC page):

- the parameters to be provided for the input target are standard. The input magnitude can be specified for a point source, for an extended source (in which case we compute an integration over the surface defined by the input diameter), or as surface brightness (in which case we compute values per pixel e.g. 106×106 mas).
- Results are given as exposure time to achieve a given S/N or as S/N achieved in a given exposure time. In both cases, you are requested to input a typical DIT, which for broad band filters will be short (10 to 30s) but for narrow band filters could be long exposures between 60 and 300s before being sky background limited.
- Do not hesitate to make use of the many graphical outputs. In particular for checking your target line (and the sky lines) in the NB filters...

The *screen output from the ETC* will include the input parameters together with the calculated performance estimates. Here some additional notes about the ETC output values:

- The integration time is given on source: depending on your technique to obtain sky measurements (jitter? or offsets?), and accounting for overheads, the total observing time will be much larger.
- The S/N is computed over various areas as a function of the source geometry (point source, extended source, surface brightness). Check carefully what was done in your case.

Most of the other ETC parameters should be self-explaining and/or well explained in the online help of the ETC.

2.4 Proposal Form

HAWK-I allows only 1 set-up: direct Imaging.

Please indicate which filters (in particular narrow-band filters) you intend to use. This will allow us to optimize their calibration during the semester.

```
%\INSconfig\{HAWK-I}\Imaging\{provide HERE list of filters(s) (Y,J,H,K,NB1060,NB1190,NB2090,H2,BrG,CH4)}
```

2.5 Overheads and Calibration Plan

When applying for HAWK-I, do not forget to take into account all the overheads when computing the required time.

- Make sure that you compute the exposure time including on sky time (not only on source) if your observing strategy requires it.
- Verify in the [call for proposal](#) that you have taken into account all listed overheads; which can also be found in Sect. [4.5](#).
- Check whether you need any special calibration: have a look at the calibration plan in Sect. [D](#) – this is what the observatory will give you as default. Any additional calibration you might need should be mentioned in the phase 1 proposal and the corresponding (night) time to execute them must be included in the total time requested.

3 PHASE 2: Preparing your HAWK-I observations

This sections provides a preliminary guide for the observation preparation for HAWK-I in phase 2, both for Service mode (SM) or Visitor mode (VM).

We assume that you are familiar with the existing generic guidelines which can be found at:

- <http://www.eso.org/observing/observing.html> Proposal preparation
- <http://www.eso.org/observing/p2pp> Service mode informations
- http://www.eso.org/paranal/sciops/VA_GeneralInfo.html VM informations

We know that they are not super-thrilling, but a quick browse over them might save (yes!) you some time during phase 2.

3.1 HAWK-I specifics to templates, OBs, and p2pp

HAWK-I follows very closely the philosophy set by the ISAAC (short wavelength) and NACO imaging templates.

3.1.1 p2pp

Using p2pp to prepare HAWK-I observations does not require any special functions (no file has to be attached except for the finding chart, all other entries are typed).

3.1.2 Observing Blocks – OBs

As an experienced ESO user, it will come as no surprise to you that any HAWK-I science OB should contain one acquisition template, followed by a number of science templates.

If this **did** surprise you, you may need to get [back to the basics](#).

3.1.3 Templates

The HAWK-I templates are described in detail in the template reference guide available through the [instrument web pages](#).

A brief overview is given below. If you are familiar with the ISAAC SW imaging or NACO imaging templates, these will look very familiar to you and cover essentially the same functionalities.

The acquisition and science templates are listed in Table 1.

Two forms of acquisition exist: a simple preset (when a crude accuracy of a couple of arcsec is enough), and the possibility to position the target interactively at a given position in the image.

The science templates provide four forms of obtaining sky images: small jitter patterns for un-crowded fields; random sky-offsets for extended or crowded fields when the off-position needs to be acquired far from the target field; fixed sky-offsets when random sky-offsets are not suited; and finally the possibility to define an arbitrary offset pattern, when the standard strategies are not suited.

Table 1: Acquisition and science HAWK-I templates

acquisition templates	functionality	comment
HAWKI_img_acq_Preset	Simple telescope preset	recommended
HAWKI_img_acq_MoveToPixel	Interactive target acquisition	
HAWKI_img_acq_PresetRRM	Simple telescope preset for RRM	not offered in P81
HAWKI_img_acq_A0	Acquisition in Adaptive Optics mode	foreseen for future implementation
science templates		
HAWKI_img_obs_AutoJitter	imaging with jitter (no offsets)	recommended for low-density fields
HAWKI_img_obs_AutoJitterOffset	imaging with jitter and random sky offsets	recommended for extended objects
HAWKI_img_obs_FixedSkyOffset	imaging with jitter and fixed sky offsets	when random sky is not suited
HAWKI_img_obs_GenericOffset	imaging with user defined offsets	

The calibration and technical templates are listed in Table 2.

The only calibration template accessible to the service mode (SM) user is the one to take standard stars.

The calibration templates are foreseen to acquire darks, flat-fields and simple standard star observations to calibrate the zero point.

The technical templates are used for the periodical characterization of the instrument. The illumination frames are used to determine the variation of the zero point as a function of detector position. The astrometry and flexure template are needed to compute the distortion map, the plate scale and relative positions of the detectors and to quantify possible flexures. Three further templates are used to characterize the detector, to determine the best telescope focus and to measure the reproducibility of the filter wheel positioning.

Table 2: Calibration and technical HAWK-I templates

calibration templates	functionality	comment
HAWKI_img_cal_Darks	series of darks	
HAWKI_img_acq_TwPreset	acquisition for flat-field	
HAWKI_img_cal_TwFlats	imaging twilight flat-field	
HAWKI_img_cal_SkyFlats	imaging sky flat-field	
HAWKI_img_cal_StandardStar	imaging of standard field	available to the SM user
technical templates		
HAWKI_img_tec_IlluFrame	imaging of illumination field	
HAWKI_img_tec_Astrometry	imaging of astrometric field	
HAWKI_img_tec_Flexure	measuring instrument flexure/center of rotation	
HAWKI_img_tec_DetTest	detector test/monitoring	
HAWKI_img_tec_Focus	telescope focus determination	
HAWKI_img_tec_FilterWheel	filter wheel positioning accuracy	

3.2 Finding Charts and README Files

In addition to the general instructions on finding charts and README files that are available at:

<http://www.eso.org/observing/p2pp>

the following HAWK-I specifics are recommended:

- The field of view of all finding charts must be 10' by 10' in size, with a clear indication of the field orientation.
- Ideally, the finding chart should show the field in the NIR, or at least in the red, and the wavelength of the image must be specified in the finding chart and the README file.
- The (IR) magnitude of the brightest star in the field must be specified in the P2PP comment field of the OB.

4 Observing (Strategies) with HAWK-I

4.1 Overview

As with all other ESO instruments, users prepare their observations with the p2pp software. Acquisitions, observations and calibrations are coded via templates and Observing Blocks (OBs). OBs contain all the information necessary for the execution of an observing sequence.

At the telescope, OBs are executed by the instrument operator. HAWK-I and the telescope are setup according to the contents of the OB.

The HAWK-I RTD is used to view the raw frames. During acquisition sequences, the RTD can be used for the interactive centering of the targets in the field.

Calibrations including DARKs, skyflats, photometric standard stars, illumination maps etc are acquired by the Observatory staff according to the calibration plan and monitored by the Quality Control group of ESO Garching, see Appendix F.

4.2 Visitor Mode Operations

Information/policy on the Visitor Mode operations at the VLT are described at:

http://www.eso.org/paranal/sciops/VA_GeneralInfo.html

Visitors should be aware that about 30 minutes/night (of night time!) may be taken off their time, in order to perform the HAWK-I calibrations according to the calibration plan.

4.3 The influence of the Moon

Moonlight does not noticeably increase the background in the NIR, so there is no need to request dark or gray time.

However, it is recommended not to observe targets closer than 30 deg to the moon to avoid problems linked to the telescope guiding/active optics system. The effect is difficult to predict and to quantify as it depends on too many parameters. Just changing the guide star often solves the problem.

Visitors should check their target positions with respect to the Moon at the time of their scheduled observations (e.g. with the tools available at <http://www.eso.org/observing/support.html>). Backup targets are recommended whenever possible, and you are encouraged to contact ESO in case of severe conflict (i.e. when the distance to the Moon is smaller than 30 deg).

4.4 Orientation, offset conventions and definitions

HAWK-I follows the standard astronomical offset conventions and definitions: North is up and East to the left.

All offsets are given as telescope offsets (i.e. your target moves exactly the other way) in arcseconds. The reference system can be chosen to be the sky (offsets 1 and 2 refer to offsets in Alpha and Delta respectively, independently of the instrument orientation on the sky) or the Detector (offsets 1 and 2 refer to the detector +X and +Y axis, respectively).

For jitter pattern and small offset, it is more intuitive to *use the detector coordinates* as you

probably want to move the target on the detector, or place it on a different quadrant (in which case, do not forget the 15" gap!).

The sky reference system is probably only useful when a fixed sky frame needs to be acquired with respect to the pointing.

For a position angle of 0, the reconstructed image on the RTD will show North up (+Y) and East left (-X). The positive position angle is defined from North to East.

Note that **the templates use always offsets relative to the original pointing**; not relative to the previous position.

For example, if you want to place a target in a series of four offsets in the centre of each quadrant: point to the star, then perform the offsets (-115,-155) [telescope moves to the lower left, star appears in the upper right, i.e. in Q3]; (-115, 115); (115, 115); (115, -115).

Do NOT do something like (-115,-115); (230,0); ... (that would be cumulative).

Note that HAWK-I offers during execution a display that shows, at the start of a template, all the offsets to be performed (see below). It provides a quick visual check whether your pattern looks as expected:

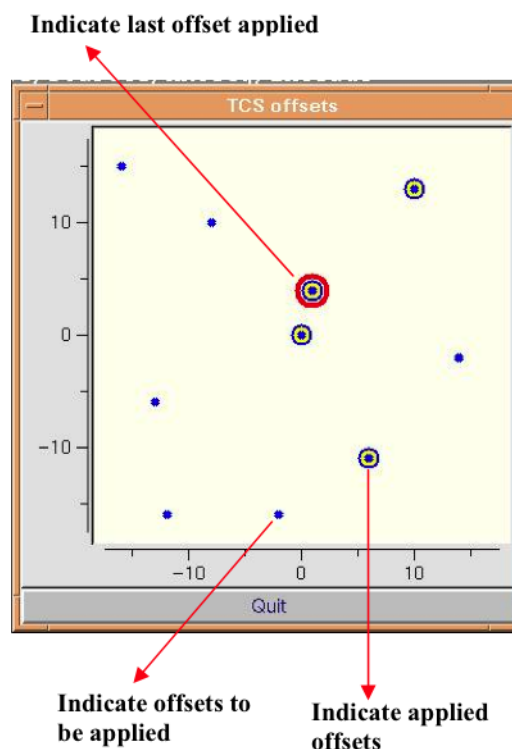

Pop-up window at the start of all template:
it provides a quick check of your offset pattern
and of the execution along the template.

In the above example, 10 offsets are requested in a 30×30 arcsec box; four offsets have already been executed, six are pending; the current offset is ~ 5 arcsec from the original pointing.

4.5 Instrument and telescope overheads

The telescope and instrument overheads are summarized below. They have been modified from the ones quoted in the call for proposal for P81, following our gained experience during commissionings.

Hardware Item	Action	Time (minutes)
Paranal telescopes	Preset	4
HAWK-I	Acquisition	(*)
HAWK-I	Initial instrument setup (for ACQ only)	1
HAWK-I	Telescope Offset (small)	0.15
HAWK-I	Telescope Offset (large $\approx 90''$)	0.5
HAWK-I	Readout (per DIT)	0.03
HAWK-I	Filter change	0.65

(*) The instrument set-up is usually absorbed in the telescope preset for a simple preset. In the case of 'MoveToPixel', the exact integration time is dependant on the number of images one needs to take (at least 2) and of course the corresponding integration time. For 3 images of DIT=2 (NDIT=1), the overhead is 1.5min.

4.6 Recommended DIT/NDIT and Object–Sky pattern

For integration time longer than DIT=120sec, the service mode user has to use one of the following DIT: 150, 180, 240, 300, 600 and 900sec.

Table 3: Sky background contribution & Useful integration times

Filter	Contribution from sky (electrons/sec)	RON limitation \sim DIT (sec)	linearity limit \sim DIT (sec)	Recommended DIT (sec)
Broad band filters				
K _s	1600	< 1	30	10
H	2900	< 1	20	10
J	350	1.15	140	10
Y	130	3	400	30
Narrow band filters				
CH4	1200	< 1	40	10
NB2090	60	7	900	60
NB1190	3.6	110	14000	300
NB1060	3.4	120	14000	300
H2	140	17	400	30
BrG	180	15	300	30

Please note that these values are indicative and can change due to sky variability especially for H band, whose flux for a given DIT can fluctuate by a factor of 2, due to variations of the atmospheric OH lines. This effect also impacts the Y, J & CH4 filters. The Moon has an effect on the sky

background, especially for the NB1060 and NB1190 filters. Similarly the variation of the outside temperature impacts the sky contribution for the K_s , BrG, H2 and NB2090 filters.

Due to the sky variations and in order to allow for proper sky subtraction, we recommend to offset at least every 5 minutes. Please be reminded that the minimum time at a position before an offset is 1 minute.

Part II

Reference Material

A The HAWK-I filters

The 10 filters in HAWK-I are listed in Table 4.

The filter curves as ascii tables can be retrieved from the [instrument web pages](#).

Note in particular that the Y band filter leaks and transmits 0.015% of the light between 2300 and 2500 nm. All other filters have no leaks (at the $<0.01\%$ level).

Table 4: HAWK-I filter summary

Filter name	central wavelength [nm]	cut-on (50%) [nm]	cut-off (50%) [nm]	width [nm]	transmission [%]	comments
Y	1021	970	1071	101	92%	LEAKS! 0.015% at 2300–2500 nm
J	1258	1181	1335	154	88%	
H	1620	1476	1765	289	95%	
K _s	2146	1984	2308	324	82%	
CH ₄	1575	1519	1631	112	90%	
Br γ	2165	2150	2181	30	77%	
H ₂	2124	2109	2139	30	80%	
NB1060	1061	1057	1066	9	70%	Optical ghost
NB1190	1186	1180	1192	12	75%	Optical ghost
NB2090	2095	2085	2105	20	81%	

Optical ghosts (out of focus images showing the M2 and telescope'spiders) have been found only with the NB1060 (Ly α at $z = 7.7$) & NB1190 (Ly α at $z = 8.7$) filters. As illustrated in Fig. 1, the ghost images are 153 pixels in diameter and offset from the central star in the same direction; however the latter varies with each quadrant and is not symmetric to the centre of the mosaic. The total integrated intensities of the ghosts are in both cases $\sim 2\%$ but their surface brightnesses are a factor 10^{-4} of the peak brightness in the stellar PSF.

The figure 2 summarizes the HAWK-I filters graphically.

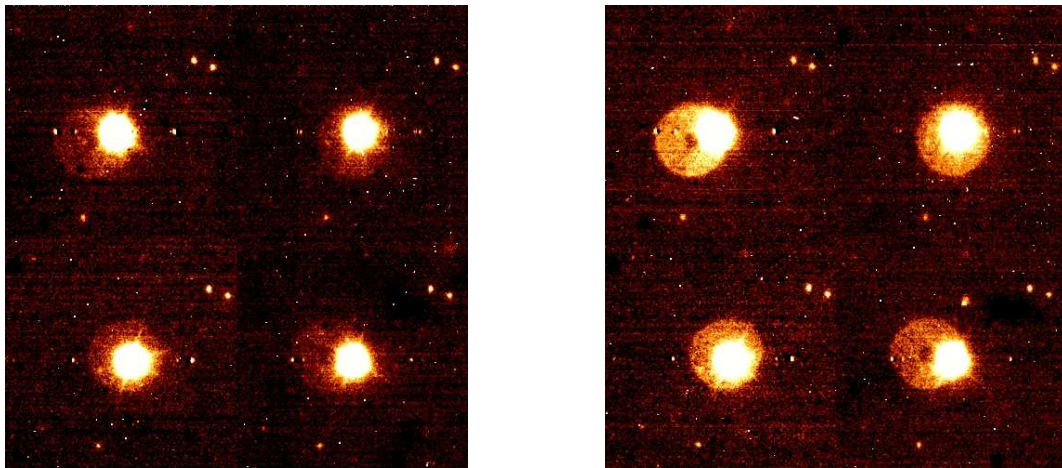

Figure 1: Smoothed enhanced images of the optical ghosts visible in the four quadrants for the NB1060 (left) & NB1190 (right) filters

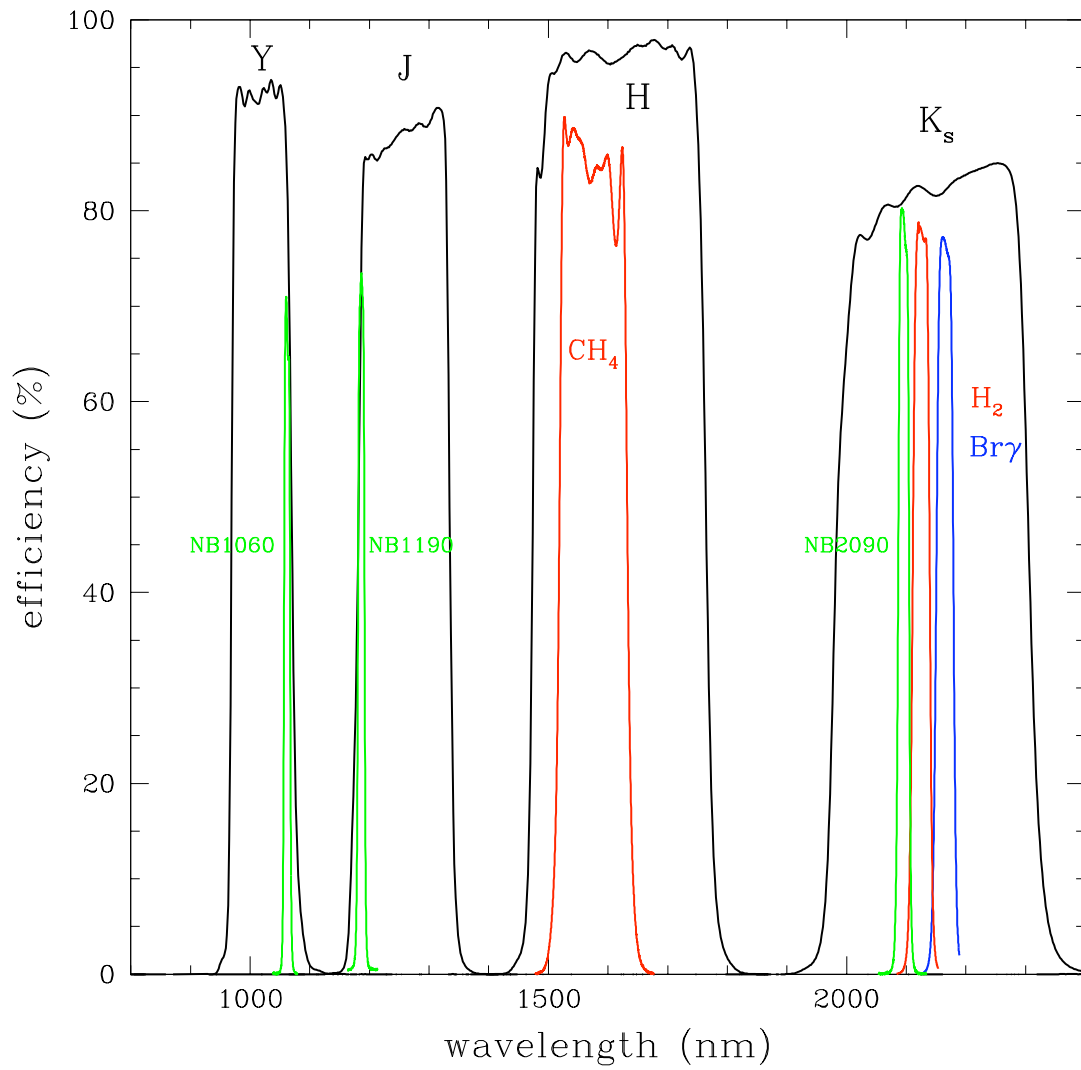
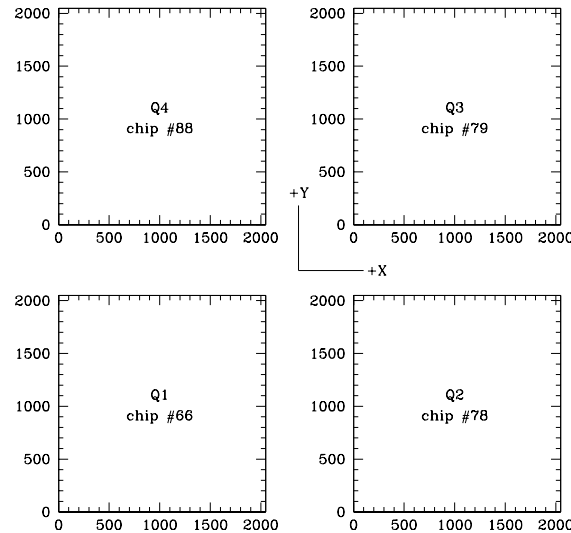

Figure 2: HAWK-I Filters. Black: broad-band filters Y, J, H, K_s, Green: cosmological filters NB1060, NB1190, NB2090; Red: CH₄, H₂; Blue: Br γ

B The HAWK-I detectors

The naming convention for the four detectors is the following:



Note that quadrant 1,2,3,4 are usually, **but not necessarily**, stored in extensions 1,2,4,3 of the HAWK-I FITS file. Indeed, FITS convention forbids to identify extensions by their location in the file. Instead, look for the FITS keyword EXTNAME in each extension and verify that you are handling the quadrant that you expect (eg. EXTNAME = 'CHIP1.INT1').

The characteristics of the four detectors are listed below:

Detector Parameter	Q1	Q2	Q3	Q4
Detector Chip #	66	78	79	88
Operating Temperature	75K, controlled to 1mK			
Gain [e ⁻ /ADU]	1.705	1.870	1.735	2.110
Dark current (at 75 K) [e ⁻ /s]	between 0.10 and 0.15			
Read noise ¹ (NDR)	~ 5 to 12 e ⁻			
Linear range (1%)	60.000 e ⁻ (~ 30.000 ADUs)			
Saturation level	between 40.000 and 50.000 ADUs			

¹ The noise in Non-Destructive Read (NDR) depends on the DIT: the detector is read continuously every ~1.3s, i.e the longer the DIT, the more reads are possible and the lower the RON. For the minimum DIT (1.3s), the RON is ~12e⁻; for DIT=10s, the RON is ~8e⁻ and for DIT>15s, the RON remains stable at ~5 e⁻.

Figure 3 represents the quantum efficiency curve for each of the detectors.

B.1 Detectors' structures

We present some of HAWK-I's detector features in two examples.

Figure 4 is a typical long (> 60s) exposure. Some features have been highlighted:

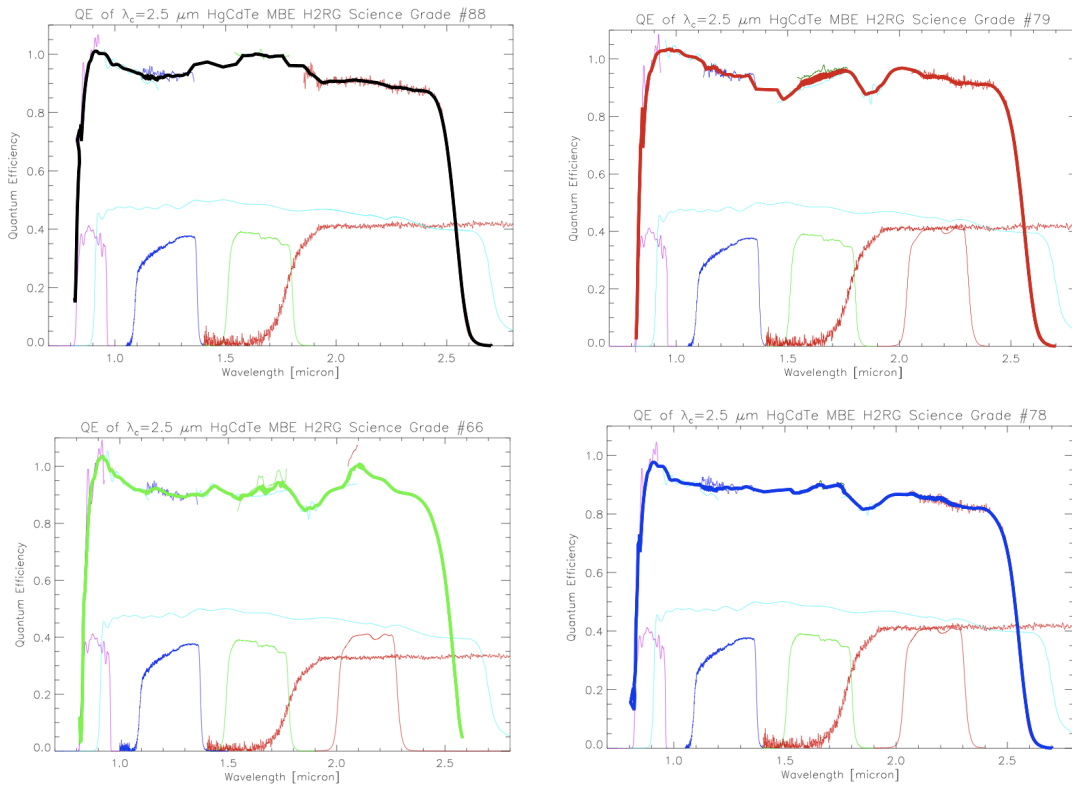

Figure 3: Quantum efficiency of the HAWK-I detectors

- 1: some black features on chip 66 & 76. For both of them, when light falls directly on these spots some diffraction structures can be seen, as shown in the corresponding quadrants in Fig. 5.
- 2: On the left (chip #88) there is an artefact on the detector's surface layer. On the right (chip #79), these are sort of doughnut shaped features. More of these can be seen in Fig. 5 on chip #88. Both features are stable and removed completely by simple data reduction (no extra step needed).
- 3: Detector glow, which is visible for long DITs but is removed by e.g. sky subtraction
- 4: The darker area visible here corresponds to the shadow of the baffling between the detectors.
- 5: Emitting structure, whose intensity grows with the integration time. It is however fully removed by classical data reduction.

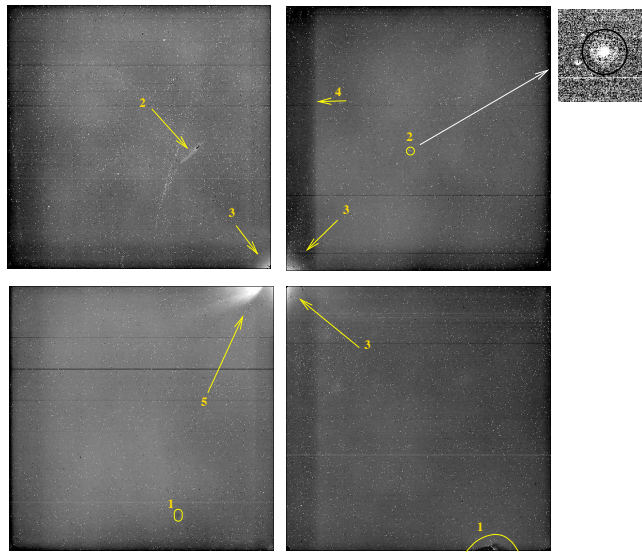

Figure 4: Typical HAWK-I dark frame (DIT=340sec)

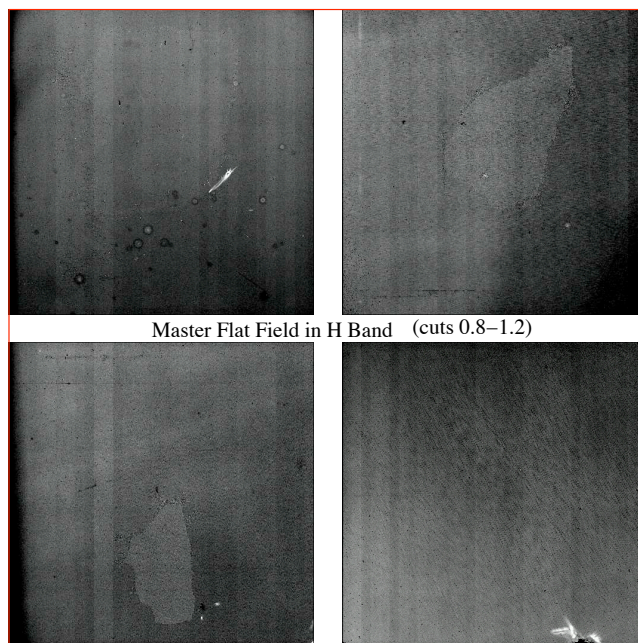
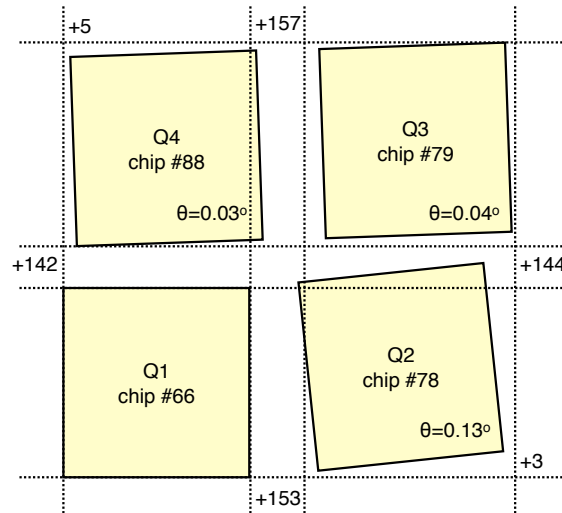

Figure 5: Typical HAWK-I twilight flat field (H Band)

C The HAWK-I Field-of-View

C.1 Relative position of the four quadrants

The four quadrants are very well aligned with respect to each other. Yet, small misalignments exist. They are sketched below:



Quadrants 2,3,4 are tilted with respect to quadrant 1 by 0.13, 0.04, 0.03 degrees, respectively. Accordingly, the size of the gaps changes along the quadrant edges.

The default orientation (PA=0 deg) is North along the +Y axis, East along the -X axis, for quadrant #1.

For reference purposes, we use the (partly arbitrarily) common meta system:

Quadrant	offset in X (pix)	offset in Y (pix)
Q1	0	0
Q2	2048 + 153	0 + 3
Q3	2048 + 157	2048 + 144
Q4	0 + 5	2048 + 142

It is valid in its crude form to within a few pixels. The distortion corrections for a proper astrometry will be added to all image headers.

Distortions (including the obvious rotation component) will be defined with respect to the above system. First qualitative evaluations with respect to HST/ACS astrometric calibration fields recovered the relative positions of objects to about 5 mas once the distortion model was applied (a precision that should satisfy most purposes).

C.1.1 Center of Rotation and Centre of Pointing

The center of rotation of the instrument **is not exactly the centre of the detector array.**

In the standard orientation (North is +Y, East is -X) the center of the detector will be located ~0.4" East and ~0.4" South of the telescope pointing.

The common reference point for all four quadrants, taken as the centre of the telescope pointing and centre of rotation, has the following pixel coordinates (to ± 0.5 pix) in the respective quadrant reference system:

Quadrant	CRPIX1	CRPIX2
Q1	2163	2164
Q2	-37.5	2161.5
Q3	-42	-28
Q4	2158	-25.5

The CRVAL1 and CRVAL2 have the on-sky coordinates of the telescope pointing (FITS keywords TEL.TARG.ALPHA , TEL.TARG.DELTA) in all quadrants.

C.2 Vignetting of the field-of-view

The Hawaii2RG detectors have 4 reference columns/rows around each device which are not sensitive to light. In addition, due to necessary baffling in the all-reflective optical design of HAWK-I, some vignetting at the edges of the field has turned out to be inevitable due to positioning tolerances of the light baffles. The measured vignetting during commissioning on the sky is summarised in the following table:

Edge	No of columns or rows vignettted > 10%	Maximum vignetting
+Y	1	14%
-Y	8	54%
-X	7	36%
+X	2	15%

The last column represents the maximum extinction of a vignettted pixel, i.e. the percentage of light absorbed in the pixel row or column, with respect to the mean of the field.

Note : although the +Y edge vignetting is small in amplitude, it extends to around 40 pixels at < 10%.

D The HAWK-I calibration plan

D.1 Do you need special calibrations?

The calibration plan defines the default calibrations obtained and archived for you by your friendly Paranal Science Operations team.

The calibration plan is what you can rely on without asking for any special calibrations. However, these are indeed the only calibration that you can rely on without asking for special calibrations!!

Thus, we strongly advise all the users to carefully think whether they will need additional calibrations and if so, to request them right in phase 1.

For example: is flat-fielding very critical for your program, i.e. should we acquire more flats (e.g. in your narrow band filters)? Would you like to achieve a photometry better than a few percent, i.e. do you need photometric standards observe right before/after your science frames? Is the homogeneity of the photometry critical for your program - i.e. should you ask for illumination frames close to your observations? Is the astrometry critical, i.e. should we acquire a full set of distortion and flexure maps around your run?

We would be more than happy to do all that for you *if you tell us so* ! (i.e. if you mention it in phase 1 when submitting your proposal).

D.2 The HAWK-I standard calibrations in a nutshell

Here is what we do, if we do not hear from you:

HAWK-I – Calibration Plan			
	TO BE UPDATED COMM1		
Calibration	number	frequency	comments / purpose
Darks	10 exp. / DIT-NDIT	daily	for all pairs with $DIT \times NDIT \leq 120$
Darks	5 exp. / DIT-NDIT	daily	for all other DIT-NDIT pairs taken during
Twilight Flat-fields	1 set / filter	daily	for broad-band filters
	1 set / filter	as needed	for narrow-band filters (as needed)
Zero points	1 set / filter	daily	zero points only
Illumination frames	1 set	monthly	zero point variations across the field
Astrometric calibration	1 + 1 sets	monthly	plate scale, distortions
Detector characteristics	1 set	monthly	RON, dark current, linearity, ...

Please do not hesitate to contact us (usd-help@eso.org) if you have any questions!

D.3 Quality Control

All calibrations taken within the context of the calibration plan are pipeline-processed and quality-controlled by the Quality Control group at ESO Garching. Appropriate master calibrations, and the raw data they are derived from, for reducing the science data are included in each Service Mode

data package along with the raw science data and the science pipeline products. More information about the HAWK-I quality control can be found under http://www.eso.org/qc/index_hawki.html. The time evolution of the most important instrument parameters like DARK current, detector characteristics, photometric zero-points and others can be followed via the continuously updated trending plots available on the HAWK-I QC webpages.

E The HAWK-I pipeline

We refer to the pipeline manual for a full description on the HAWK-I pipeline. This section provides only a very brief overview of what to expect from the pipeline.

The pipeline full documentation will be made available in the HAWK-I Pipeline User Manual (VLT-MAN-ESO-19500-4407) in April 2008 together with the 1.0 public release.

The planned data reduction recipes included in this delivery will be:

- `hawki_img_dark`: The dark recipe produces master dark and bad pixel map.
- `hawki_img_flat`: The flat-field recipe produces a master flat, a bad pixel map, a statistics table, the fit error image.
- `hawki_img_zpoint`: This recipe provides the zero points for the UKIRT selected standards.
- `hawki_img_detlin`: This recipe determines the detector linearity polynomial coefficients computation as well as the error on the fit.
- `hawki_img_illum`: The illumination map of the detectors is obtained by observing a bright photometric standard consecutively at all predefined positions over a grid.
- `hawki_img_jitter`: All science data resulting from the jitter and generic offset templates. The four quadrants are combined separately. The four combined products are eventually stitched together. The online reduction pipeline, working on Paranal, will not provide this stitched image if $\min(\text{offset}) < -1500$ or $\max(\text{offset}) > 1500$.

Besides, utilities will be provided to make it easier for the users to reduce the data by hand, step by step. This utilities list is not finalised yet, but will contain among others:

- `hawki_util_distortion`: Apply the distortion correction
- `hawki_util_stitch`: Stiches 4 quadrant images together
- `hawki_util_stdstars`: Generates the standard stars catalog from asii files
- `hawki_util_gendist`: Generates the distortion map used for the distortion correction