Tetra Personal Multigas Monitor



User Manual

M07237

May 2010
Issue 10

Safety information:

- Read and understand all instructions in the operation section of this manual before use.
- Do not substitute components as this may impair intrinsic safety and invalidate warranty.
- Observe all warnings and instructions marked on the unit and within this manual.
- Observe site health and safety procedures for gases being monitored and evacuation procedures.
- Make sure you understand the screen display and alarm warnings.
- If this product is not working properly, read the troubleshooting guide or call Crowcon.
- Ensure qualified service personnel change sensors and operating system.
- Ensure maintenance and calibration are carried out in accordance with the procedures in the manual.

Instructions specific for use in hazardous areas

The following instructions apply to equipment covered by certificate number:

BASEEFA03ATEX0193

The following information covers all relevant points listed in clause 1.0.6 of the EHSR's of the ATEX directive.

1. The certification marking is as follows:

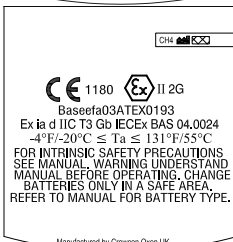
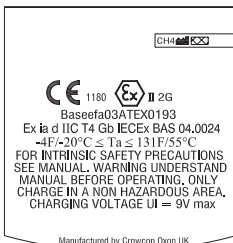

2. The equipment may be used in zones 1 and 2 with group IIA, IIB, and IIC flammable gases, temperature classes and vapours T1, T2, T3 and T4 with rechargeable battery option and classes T1, T2 and T3 with non-rechargeable battery option.
3. The equipment is certified for use in ambient temperatures in the range -20°C to +55°C

(-4°F to +131°F). The equipment should not be used outside these ranges.

4. Compliance with the Essential Health and Safety Requirements has been assured by compliance with EN50014:1997 + Amds 1 & 2, EN50020:2002 and EN50018:2000, as certified by Baseefa. Compliance with gas detection performance standards EN50054, EN50057, EN61779-1, EN61779-4, EN50104 and EN50270 has been certified by Lloyd's Register.
5. Repair of this equipment and gas sensor replacement shall be carried out by the manufacturer or in accordance with the applicable code of practice.
6. If the equipment is likely to come into contact with aggressive substances, then it is the responsibility of the user to take suitable precautions that prevent it from being adversely affected, thus ensuring that the type of protection is not compromised.
7. The rechargeable battery must only be charged in non-hazardous (safe) areas by connection to the specified Crowcon charger power supply.
8. Only the following cell types may be fitted in the battery compartment of the non-rechargeable battery pack:

Duracell MN1500 LR6

Varta 4006

Ever Ready Energizer LR6

GP Batteries 15A LR6 1.5V

The cells must only be changed in a non-hazardous (safe) area.

9. The equipment is not certified for use in atmospheres containing more than 21% oxygen.

Area Classifications: -

Zone 1: An area classified as Zone 1 is likely to have ignitable concentrations of flammable gases, vapours or liquids present under normal operating conditions.

Zone 2: An area classified as Zone 2 is not likely to have ignitable concentrations of flammable gases, vapours or liquids present under normal operating conditions.



© Copyright Crowcon Detection Instruments Ltd 2010. All rights are reserved. No part of the document may be photocopied, reproduced, or translated to another language without the prior written consent of Crowcon Detection Instruments Ltd.

Publication number: M07237

Tenth edition: May 2010

Tetra

Personal Multigas Monitor

Contents

Unpacking	1
Quickstart guide	2
I. Introduction	6
II. Operation	8
III. Batteries	12
IV. Alarm indications	14
V. Fixing accessories	15
VI. Flow sampling	16
VII. Maintenance and calibration.....	21
VIII. PC interface and software.....	23
IX. i-module replacement.....	24
X. Specification.....	26
XI. Accessories and spare parts	27
XII. Troubleshooting guide	29
Appendix: Limitations of sensors.....	30

Tetra

Personal Multigas Monitor

Thank you for purchasing the new *Tetra Personal Multigas Monitor*. Tetra has redefined portable gas monitoring and will give you years of unparalleled service and reliability.

Please read the instructions carefully before use. Keep the manual for future reference.

Unpacking

Remove the Tetra Personal Multigas Monitor from the packaging. The Tetra accessories will be located in the bottom of the box. Check the contents are complete, you should have:

- Tetra unit;
- Optional battery charger power supply for units supplied with rechargeable Li-ion batteries;
- A configuration report detailing the sensors installed, alarm settings and a calibration certificate;
- Optional accessories such as flow adaptor and aspirator bulb;
- Optional spare battery pack for non-rechargeable units.

Battery check

The Tetra Personal Multigas Monitor has two battery options: Li-ion rechargeable or alkaline non-rechargeable batteries. Depending on the battery option chosen, the Tetra will operate for a minimum of 12 hours and up to 18 hours when fully charged.

Rechargeable units

Tetra uses a Li-ion battery pack and should arrive with sufficient charge so that the unit can be used straight out of the box. However, if this is the first time you have used the Tetra unit, you may need to charge the batteries to attain the full 12 to 14.5 hour operating time. (The actual operating time will depend on the types of sensors installed.)

Warning: rechargeable units

Do not attempt to use any other charger power supply with this unit except the one supplied by Crowcon. Failure to comply could invalidate safety certification and may result in permanent damage to the unit.

Quickstart guide

1. Getting started

Review your Tetra unit

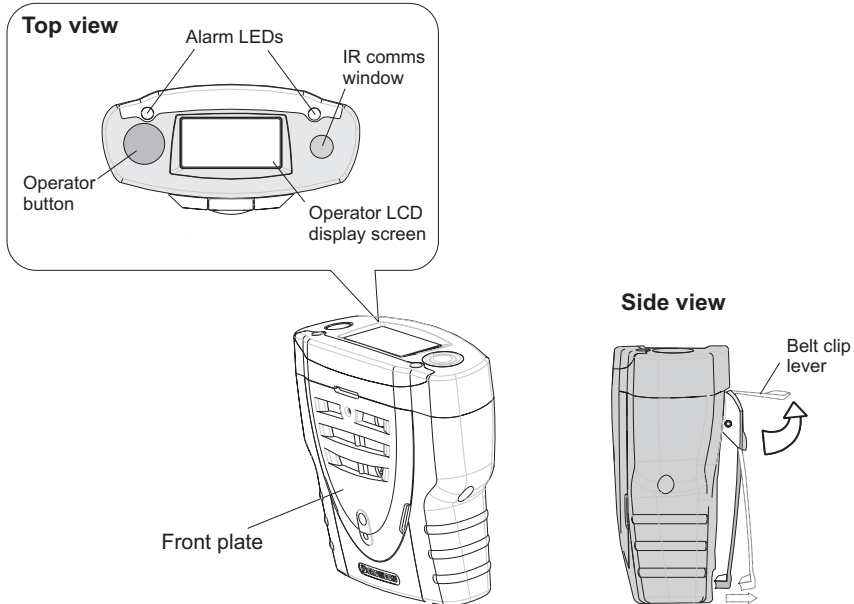

Switching on your unit

Tetra requires little setting up, follow these simple steps to get your unit ready for use.

1. Ensure the unit is in clean air.

2. Switch on

Press and hold the operator button until the red LED flashes.

The operator display screen will light up and the unit will begin a warm up sequence.

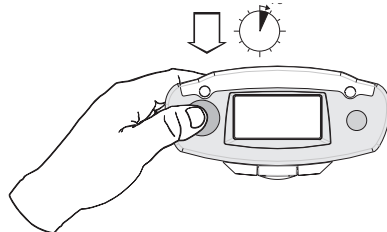

Tetra warm up sequence

- a) The unit will test the alarm LEDs, sounder, vibration alerts, and the operator display screen. The sounder may be silenced by pressing the button.

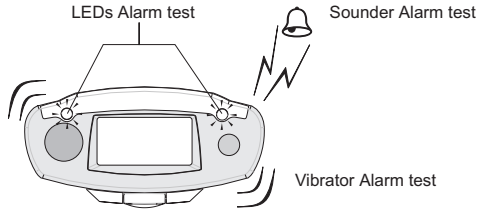

- b) The unit will continue through a warm up sequence as shown below, this will take approximately 45 seconds.

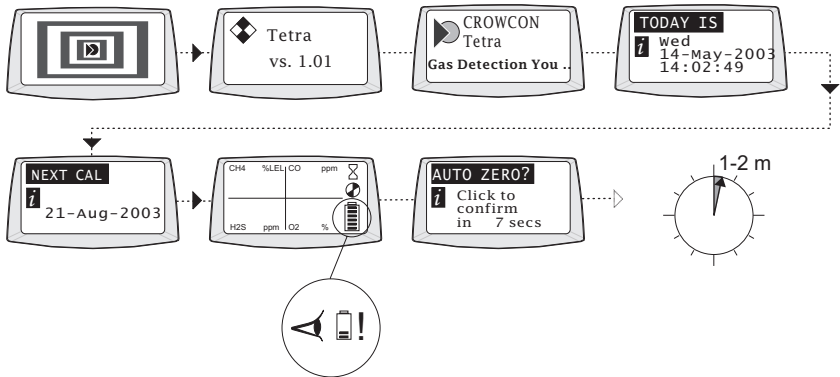

c) Auto zero

If auto zero is enabled (default), the unit will display the auto zero menu. Press the operator button with a single click to confirm auto zero. If the operator button is not pressed within the 10 second time out, Tetra will proceed directly to Run mode without performing zero.

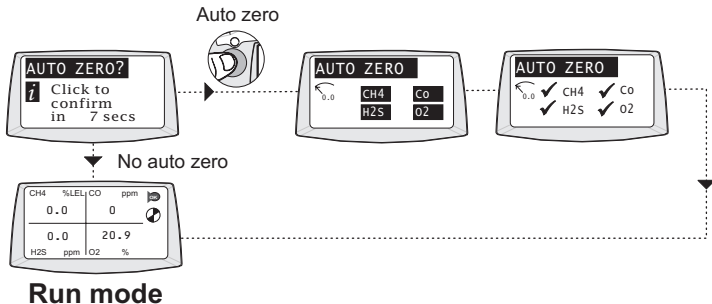

Run mode

Your unit is now ready to use. Below is a typical screen display showing the unit in normal gas monitoring Run mode.

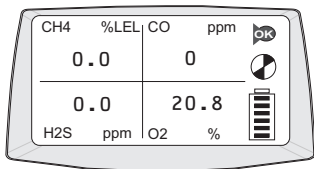

Familiarise yourself with the gases being monitored in your unit and make sure you understand site health and safety procedures in the event of alarm conditions.

Tetra units with an inbuilt pump will produce a low humming noise, this is normal.

Screen Icons

- Warm up
- Flashing icon, Tetra running normally
- Pump
- Battery
- Auto zero

Confidence signals

In normal Run mode, Tetra will emit a short beep every 10 seconds and the OK icon flashes to show operational health.

2. In the event of an alarm

Alarm signals

In the event of gas concentrations exceeding the alarm thresholds for any gas being monitored, Tetra will activate the alarm signals.

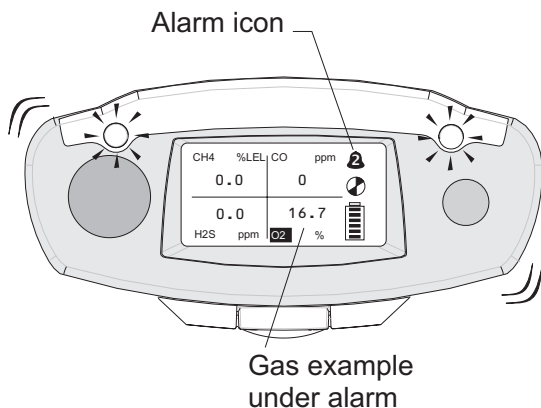

Alarm signals

The red and blue alarm LEDs will flash, the sounder will emit a loud, fast series of beeps, the internal vibrator alarm will activate. The operator screen will display the gas in alarm and the alarm level. See the figure to the left.

1. When the gas level returns to normal, press the operator button. This will reset your Tetra unit to normal Run mode. If gas levels are still in alarm, the button will have no effect.

For any one gas, there are normally two alarm thresholds. These are indicated by the alarm icons shown.

The Tetra alarm is set to latch by default. The unit will still continue in alarm mode even when gas levels return to normal, until the alarm is cleared, by pressing the operator button.



3. Switch off unit and storage

Switching off unit

1. Press and hold the button for 5 seconds. The shut down menu appears, continue to hold button until the unit counts down to shut off.

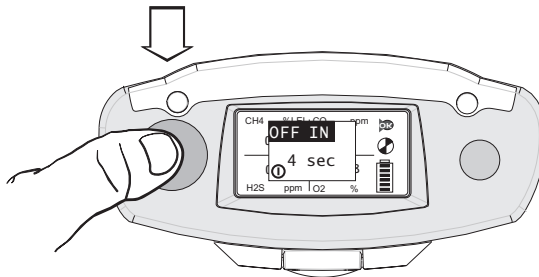

Storing conditions

In order to optimise sensor performance and lifetime, your Tetra unit should be stored in a safe, non-hazardous area, 0-30°C, 10-90%RH.

4. Additional information

- For battery recharging information go to section III.
- For fixing accessories go to section V.
- For sampling section go to section VI.
- For calibration information go to section VII.
- For troubleshooting guide go to section XII.

I. Introduction

Thank you for purchasing the new *Tetra Personal Multigas Monitor*. Tetra is a portable multigas detector, designed to be carried or worn by individuals working in hazardous environments such as confined spaces. It is suitable for use in Zone 1 and 2 hazardous areas. Tetra can monitor up to four different gases and display the readings simultaneously on a display screen. Alarm warnings are given through a combination of a loud audible alarm, a bright visual alarm of blue/red flashing LEDs and an internal vibrator. Tetra can be fitted with a wide range of modular, plug and play gas sensors. Each sensor carries an intelligent processor which contains calibration and sensor information.

Tetra is battery operated and is available with rechargeable and non-rechargeable battery options. The rechargeable unit contains its own internal charger, a battery charger power supply is available for 110 V or 230 V a.c. see section XI for more information.

At Crowcon we recognised the need for a reliable and robust confined space personal monitoring system, which is lightweight, compact, easy to use and cost effective. Tetra has a single operator button, and an intelligent user-friendly display with automatic backlight. Gas levels are continuously monitored providing normal gas readings, peak readings and time weighted averages (TWA). Tetra is available as a diffusion sampling instrument or with built in electric sampling pump. Configuration and data/event logging is handled by Crowcon Portables PC software, the PC communication link being provided through a fast, reliable optical link.

Tetra's shape and design makes it comfortable to wear and as non-intrusive as possible, with a non-slip grip for better handling. Extra accessories, such as shoulder strap and chest harness, can be purchased.

Tetra has been designed from top to bottom to bring you a revolution in ease of use, maintenance and extreme reliability. Through innovative and rigorous design technology, we have introduced several new features.

i-module gas sensor

Tetra uses unique plug and play i-module sensor technology. Each sensor unit incorporates its own intelligent processor holding sensor configuration and calibration data. Different sensors can be purchased, and once inserted, are immediately ready to run. Tetra can operate with up to four sensors and display, simultaneously, information and gas readings for all the sensors on one screen. This means no redundancy and assured future investment in your Tetra

unit, allowing you to swap sensors between units or configure your unit, as appropriate, to your current needs. Plug and play will ease maintenance time and cost, and the intelligent modular system will remove the need to calibrate each sensor. Additional i-modules can be purchased pre-calibrated from your local supplier.

Reliable, anti-shock mechanics and robust housing

The Tetra housing is built from resilient material, giving it strength and flexibility to withstand the hardest of working conditions, water and dust tight to IP65, and with a non-slip grip. The internal structure has been carefully designed to make servicing easy and at the same time very rugged. If the unit is dropped, there will be no disruption of power or function, ensuring reliability and service for years to come.

Software

The internal software in Tetra has been designed and written in accordance with the requirement of IEC 61508 to ensure quality and integrity of operation. Tetra has been designed to give a truly reliable personal gas monitoring system. The internal circuitry includes an external watchdog, the software monitors for any malfunction within the unit and will display an error warning to the user should they occur.

II. Operation

2.1 Switch-on sequence

1. **Ensure the unit is in clean air.**
2. **Switch on**

Press and hold the operator button until the red LED flashes.

The instrument begins with testing all the LCD segments on the operator display screen, the red and blue alarm LEDs, sounder and internal vibrator alert for about 5 seconds. The sounder may be silenced by pressing the button. The unit enters a warm up mode and displays a sequence of screens, see page 3 for more details. At the end of warm up, the auto zero menu will be displayed.

The auto zero function can be disabled or set to run automatically, without user confirmation: autozero menu will not appear. See section VIII PC Interface and software.

**Battery check**

Use this time to check there is sufficient charge in the battery pack

NB. During the warm up sequence, the date for next calibration will be displayed. If the date has expired or has passed, the Tetra unit will display a warning message that calibration is due. The instrument can still function, but it is strongly recommended the unit is sent for calibration as soon as possible.

Tetra can be set, using the Portables PC software, for the instrument to shut down automatically, if the calibration date is passed, to prevent further operation of the instrument.

3. **Auto zero menu**

Press the operator button with a single click to confirm auto zero. If the operator button is not pressed within 10 seconds, Tetra will proceed directly to Run mode without performing a zero. Flammable and toxic sensors will be set to read zero and the oxygen sensor to read 20.9%.

NB. If auto zero fails, a warning message will be displayed and an 'X' will appear against the sensor that has failed.

Switch off

To switch off the unit, press and hold the operator button for 5 seconds. A shut-down message 'OFF IN' will appear, continue to hold button until the unit counts down to shut off.

2.2 Run mode

The Tetra unit will display up to four gas readings simultaneously on the operator display screen. A typical display with four sensors installed, is shown below.

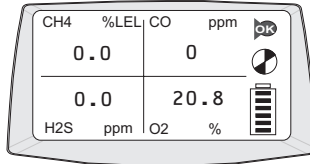

Each channel will display the gas name, units and current value. Familiarise yourself with the gases currently being monitored in your unit. Ensure you understand site health and safety procedures. For information on peak and TWA readings, go to section 2.4.

Confidence signals

To reassure users the unit is working correctly, the Tetra unit will emit a short beep every 10 seconds and the OK icon will flash. The pump is running correctly when the icon is revolving.

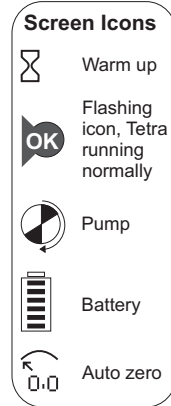

2.3 Display symbol guide



Battery

A full battery is represented by a battery icon showing a full six bars. A low battery charge will show 1 to 2 bars. When zero bars are shown the battery icon flashes. The sounder will emit warning bleeps.

If the battery becomes too low, Tetra will display a 'Battery low' warning message and switch off.



Internal pump

This revolving icon indicates the internal pump is running. If the pump or airway becomes blocked, the unit will emit a warning sound and display a warning message. Check the flow adaptor and sample lines are free from dirt or water, and that the sample line is not kinked or blocked. Restart pump by pressing the operator button.



TWA alarm

Tetra will display the TWA alarm when the 15 minute or 8 hour time weighted average alarm threshold is passed for toxic gases.

2.4 Display options

Tetra provides two additional selectable displays:

Peak display

When Peak mode is selected the instrument shows the highest value for flammable and toxic gases and the lowest value for oxygen since the mode was selected. This is useful for vertical entry checks where the whole instrument can be lowered down the shaft rather than just a sampling tube. Deselecting Peak mode clears stored peak information.

TWA display

Shows the 15 minute or 8 hour time weighted average (TWA), for toxic gases, monitored since last turn on.

1. To view the additional display option menu, double-click the operator button.

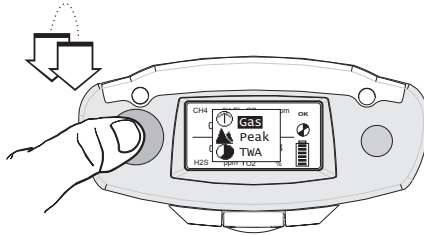

2. Press the operator button with a single click to scroll through the list. When your choice is highlighted, double-click the operator button.



The Tetra operator screen will display the peak or TWA icon and the gas readings recorded.

Peak test

When performing a peak test, such as a vertical entry check, previous readings can be cleared on entry to the peak display option.

Zero

The Tetra instrument can perform an autozero by selecting the Zero function from the menu. When zero is completed, the instrument will return to normal operation.

2.5 Logging

Tetra incorporates data and event logging which can be accessed using the IR communications link with Portables PC software (See section VIII). It can record data each minute for 50 hours up to a limit of 1500 events.

Tetra records the time and date for a number of operating and diagnostic events including:

- Switch on and switch off
- Level 1, Level 2 and Time Weighted Average Alarms, alarm on, alarm off and the peak level during the alarm
- Zero, calibration and gas test with success or failure
- Pellistor saver on and off
- The battery condition is logged every 15 minutes while the instrument is operating, and certain configuration changes are also logged.

III. Batteries

3.1 Rechargeable batteries

Recharge time for the Li-ion batteries is less than 6 hours (less, if they are not fully discharged). Rechargeable batteries will typically last 12+ hours, fully loaded with 3 or 4 sensors and a pump.

Charging the batteries

1. Ensure you are in a safe area.
2. Plug the charger power supply into a mains socket.
3. The charging socket is located on the bottom of the unit: there is a small cover which can be opened to reveal the socket, (see figure below). Pull back the cover and insert the lead into the socket. Switch on the power.

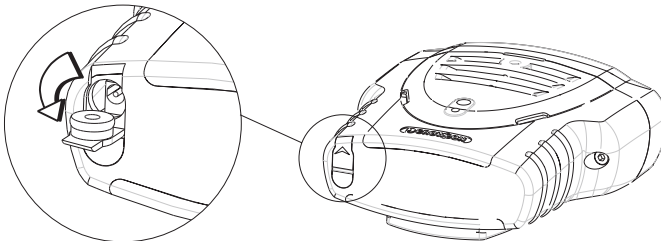

The unit would normally be left switched off for charging and will display a battery icon on the display sweeping from empty to full. When charging is complete a full battery icon flashes on the screen. If the unit is switched on during charge the normal display battery icon sweeps from empty to full. On disconnecting the charger power supply this display icon will update in 20 seconds to show actual charge state. The unit is fully charged when the charging battery icon is flashing (see

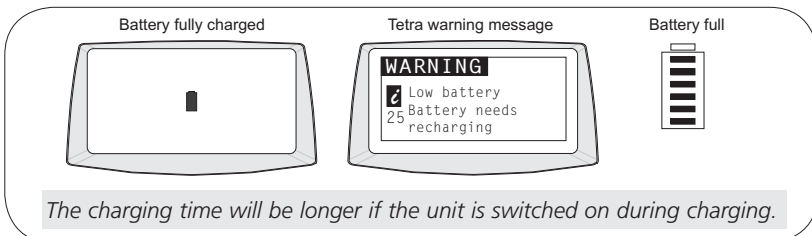

The charging time will be longer if the unit is switched on during charging.

example). In Run mode, the battery icon will display six bars when it is full.

4. Remove the lead from the charging socket and replace the protective cover.

3.2 Non-rechargeable batteries

Tetra uses a three AA alkaline battery pack which will give 11 hours operating time. The following battery types are suitable for the non-rechargeable version:

Energizer type LR6 MN1500
Gold Peak type 15A LR6
Duracell type MN1500 LR6
Varta type 4006

Alkaline batteries will typically last 11 hours.

To replace the battery pack, ensure you are in a safe, non-hazardous area. The battery pack is located in the bottom of the instrument. Remove the access cover and withdraw the battery pack. Replace the 3 x AA cells, then reinsert the pack into the instrument and replace and securely fasten the access cover.

IV. Alarm indications

Tetra provides two instantaneous alarm levels for each installed sensor, designated level 1 and level 2. For toxic gas sensors, there are also two time weighted average alarms (TWA), one for short term exposure (STEL): based on a 15 minute time weighted average, and the second TWA alarm is for long term exposure: based on a 8 hour time weighted average.

Alarm configurations are set via the Crowcon Portables PC software. The following settings can be made:

Alarm thresholds for each sensor: Level 1 and level 2 alarms can be set for each individual gas sensor. 

Alarm type: This can be set to rising levels of gas concentration, or as falling. Oxygen sensors are set to falling for deficiency monitoring.

Alarm latching: Alarms can be set to be latched or unlatched. Latched alarms will require the operator button to be pushed in order to clear the alarm. This is the default setting. Unlatched alarms will clear automatically when the gas hazard has passed.

Alarm mute: The sounder can be set to mute for level 1 alarm only; pressing the operator button during an alarm condition ie presence of hazardous gas, will silence the sounder and stop the vibration alarm. The alarm LEDs will continue to flash.

Alarm sounder tone: Different tones can be selected to achieve the best performance for the monitoring conditions available.

In the event of a Time Weighted Alarm (TWA)



In the event the 15 minute or the 8 hour TWA is triggered, Tetra will go into alarm and display the TWA icon with the toxic gas readings. The 8 hour TWA alarm cannot be cleared.

V. Fixing Accessories

Belt clip

Tetra has a strong built-in belt clip located on the back of the unit. Lifting the small lever will allow the unit to be attached to a belt more easily.

Universal harness plate

Crowcon provide a universal harness plate which can be used with either a chest harness or a shoulder strap.

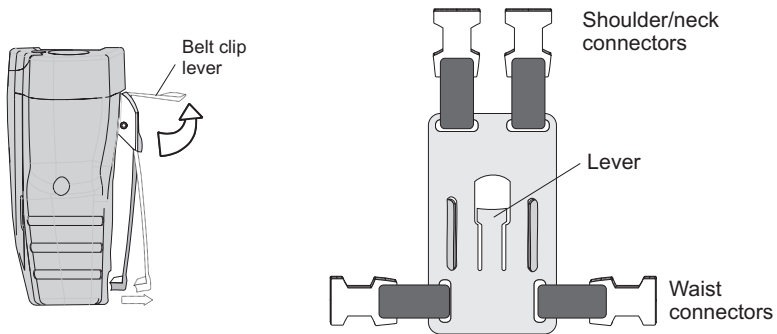

How to wear your Tetra unit

Chest harness

Slide the universal harness plate over the belt clip at the back of your Tetra unit. The plate will lock automatically into place. Create a chest harness by attaching one strap to the top connectors, to go around the neck, and the other to link around the waist using the side connectors. Adjust the lengths until the Tetra unit is in a comfortable working position.

Shoulder strap

With the universal harness plate in place on the belt clip, attach the shoulder strap accessory onto the top connectors. Adjust to a comfortable working position.

See accessories, section XI, for full list.

VI. Flow sampling

Attaching the flow adaptor plate

To perform manual sampling using Tetra, a flow adaptor plate must be fitted onto the front of the instrument.

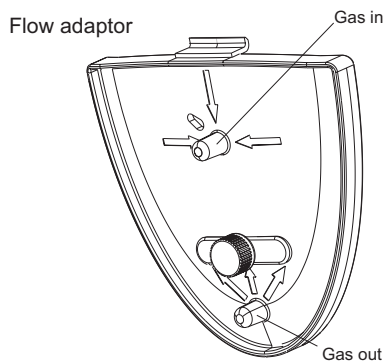

1. To fit the flow adaptor plate, slide the top of the flow adaptor plate into the small recess on the front of the instrument, screw the thumbscrew until the plate is tightly fitted into place.
2. Attach the sampling tube or flow accessory onto the gas inlet nozzle.
3. **Non- Pumped (diffusion) instruments**
Attach the aspirator bulb onto the gas outlet nozzle.
4. To remove the flow adaptor plate, unscrew the thumbscrew and lift the plate away from the instrument.

The sampling tube supplied is normally a 2m (6ft) length. Longer lengths of sampling tube can be provided, but will increase the time taken to get a sample from the point of sampling to the Tetra instrument. When using an extended length of tubing a response time test is recommended. Gas of known concentration should be sampled along the full length of tubing to be used and the time taken for the sensor reading to reach the known gas levels should be noted. This time should be used as the minimum for sampling before readings should be taken.

Pumped instruments

Tetra's inbuilt pump draws sample air in through the inlet nozzle of the flow adaptor plate and out through the outlet nozzle. When using sampling equipment, if the inlet should become blocked with dirt, water or a kink in the line, the pump will automatically stop. Tetra will emit a rapid series of beeps and display a warning message. To restart the pump, clear the blockage and press the operator button.



Extension probes, drop lines and water traps are available. See accessories section XI.

Diffusion instruments

When using the manual aspirator kit, adopt a consistent style whilst using the hand aspirator. Crowcon recommend squeezing once per second to achieve a flow rate of approximately 0.5 - 1 litre/min. At least 10 pumps per sample are recommended.

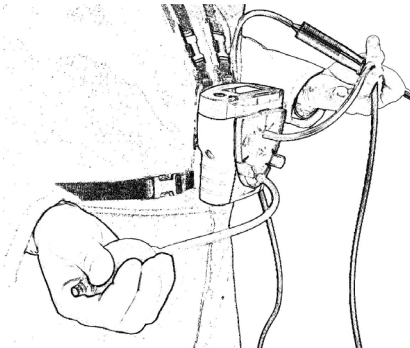

Tetra gas test accessory kit

The Gas Test Accessory is a gas testing kit designed to enable gas testing of the Tetra multigas detector using a specially formulated, high stability long life quad gas mix. It can be used with Tetra units having sensors for Flammable, Oxygen, Carbon Monoxide and Hydrogen Sulphide gases, and all Tetra units with these sensors can be gas tested using the kit.

6.1 Gas testing

Gas testing checks the sensor is responding within set limits to an applied gas of known composition. This can be performed as often as desired, but would usually be carried out each time the Tetra is issued for use. The Tetra itself will determine Pass/Fail status for the gas test.

In order to perform successful gas tests ensure:

- The quad gas mixture used has the correct gas concentration, and that it is within the validity date specified by the supplier.
- The gas flow path is leak tight. It is important to check that the flow plate is properly fitted to the Tetra, and the outlet tubing is not restricted in any way, nor additional tubing length used.

The Gas Test Accessory Kit is supplied in a convenient carry case and comprises; a gas cylinder containing the quad gas mix, a 'Trigger' regulator with interconnect tubing, a magnet - used to activate Test mode, an aspirator plate to attach to the Tetra and a vent line. The Trigger regulator can be operated in two ways: (1) squeeze and hold - allows gas flow as long as the lever is held in, or (2) by lifting the lever - the flow is locked on. There are two versions of the kit; one for pumped Tetra units and one for non-pumped Tetra units supplied with an aspirator plate. Pumped Tetra units require the use of the plate with the integral bellows assembly.

6.2 How to perform a gas test

1. Ensure your Tetra unit is switched on and in normal operation.
2. Clip the flow plate onto the front of the unit and attach the hose from the Trigger regulator.
Attach the outlet hose to 'vent gas away' - do not extend this hose and do not restrict or allow kinks.
3. Swipe the magnet past the display adjacent to the LED lens. Your Tetra unit will activate the Gas Test and show 'GAS TEST' on the display.
4. Tetra will display a progress bar at the bottom, the names of the gas

sensors fitted are shown with a cross beside each.

Operate the Trigger regulator and apply gas to the Tetra whilst the progress bar is counting down.

As gas flows and the sensors respond, the Tetra monitors the response against stored gas values. Provided the response reaches a predefined window around each gas value within the test time the cross by each sensor will change to a tick and the unit passes the test.

If any sensor response fails the test the Tetra will display a message advising the unit be sent for calibration.

6.3 How to perform a field calibration test

To perform a field calibration test, you must first Zero your Tetra unit 15 minutes or less before commencing the gas test instructions.

1. Follow steps 1 to 3 given in 6.2. Tetra will display an alternate screen message:

**Calibrate?
Click to
Confirm
In 10 seconds**

2. Press the button within 10 seconds to confirm Calibration.

If the button confirmation for calibration is not made within 10 seconds then the process will revert to gas test as in 6.2.

3. Apply calibration gas following step 4 in 6.2.

Tetra will display a progress bar at the bottom, the names of the gas sensors fitted are shown in reverse image with a cross beside each.

Operate the Trigger regulator and apply gas to the Tetra whilst the progress bar is counting down.

As gas flows the Tetra allows the sensors to respond and then adjust the value for each gas channel to match the stored calibration gas value within each sensor i-module. Provided all channels calibrate successfully within the allowed time the calibration will be designated successful. If any channel does not calibrate successfully it will remain marked with a cross and screen a message 'Gas test failed' and 'Send for calibration' will be displayed. A tick will appear against each channel as the unit passes the test

4. To abort the Calibration test press the button at any time whilst the test is in progress.

6.4 Cal/Test

This can arise if having selected and confirmed calibration one or more (but not all) of the sensors are not calibrate enabled. In this case calibrate enabled channels will calibrate, and non-enabled channels will Gas Test (bump) only.

Oxygen i-modules are usually not set to calibrate enabled as the calibration at 20.9% on atmospheric air during the zero process is more accurate and repeatable than using certified gas mixtures. Provided it completes a successful test and the other i-modules fitted successfully calibrate the calibration due date for oxygen will be reset during a Cal/Test.

6.5 Gas test/calibration troubleshooting

Symptom	Possible Cause	Action
No response to gas	Gas cylinder empty	Check gauge, replace cylinder as needed
	Hose blocked or kinked	Ensure no restriction to flow
Tetra fails gas test	Gas cylinder empty	Check gauge, replace cylinder as needed
	Gas cylinder out of date	Check date and replace as needed
	Hose blocked or kinked	Ensure no restriction to flow
	Calibration drifted	Calibrate Tetra
	Gas flow not started immediately	Repeat test, starting gas immediately
Tetra fails calibration	Gas cylinder empty	Check gauge replace bottle as needed
	Gas cylinder out of date	Check date and replace as needed
	Hose blocked or kinked	Ensure no restriction to flow
	Calibration drifted	Calibrate Tetra
	Stabilisation time too short	Reset using PC software
Tetra passes gas test but will not enter calibration mode	Menu Zero not performed Tetra not field calibration version	Select Zero from menu Send for re-configuration

Note: Remove regulator from gas cylinder when not in use over a prolonged period.

For parts list, see section XI.

VII. Maintenance and Calibration

Tetra is designed to operate almost maintenance free under most conditions. However, some small items of routine maintenance are recommended.

General

To keep the display panel and operator button free from dirt build up, regularly wipe over your Tetra unit with a damp cloth.

Filter

Inspect the front filter at regular intervals for dirt or damage. Replace with a new filter/front grille if necessary, part number CO1852.

Zero and calibration

Tetra is supplied with an auto zero function on start-up. This function can be configured to operate automatically, on user confirmation (see quick start guide), or can be disabled. This configuration can be set with the Crowcon Portables PC software, see section VIII. Tetra also has a zero function in the menu. See section II.4.

Crowcon recommends, as a minimum, a monthly gas test to confirm sensor operation. A test gas of known composition, needs to be applied, to verify sensor response and alarm function.

Instrument calibration of all sensors should be performed at 6 month regular intervals.

Calibration method

Tetra calibration can either be performed using the Portables PC software or by use of the Gas Test Accessory Kit. Using the Portables PC software allows calibration using either single gas mixtures, and calibrating each sensor in turn, or using a multigas mixture for simultaneous calibration. The Gas Test Accessory Kit allows calibration on a quad gas mixture for the standard 4 gas combinations of flammable, oxygen, carbon monoxide and hydrogen sulphide.

Calibration and Gas Testing require the use of the correct type of flow plate as follows:

Non pumped units - use either the standard flow plate or the clip on calibration flow plate C011005

Pumped units with software version 1V07 or lower. The pump is

always running even in Calibration or Gas Test modes - it is essential to use the C01874 'bellows' style flow plate.

Pumped units with software version 1V08 or later where the default configuration is that the pump is automatically switched off in Calibration or Gas Test mode. Use the clip on calibration flow plate C011005 unless the default configuration has been changed to maintain the pump running for Calibration or Gas Test in which case it is essential to use the C01874 'bellows' style flow plate.

Ozone detector calibrations

Always calibrate Crowcon ozone detectors with ozone only.

Fittings:

For ozone calibrations all fittings and pipework should be stainless steel, brass, aluminium or PTFE. Fittings or pipework in other plastic materials such as Tygon must not be used.

Gas flow rate:

It is important that the flow rate is set correctly as otherwise pressure effects may distort calibration values and prevent the gas detector from working correctly. To calibrate Crowcon portable detectors the flow rate should be set between 0.8-1.0 litres / minute (0.03-0.04 cubic feet / minute).

Normal safety precautions for handling ozone should always be observed along with any special instructions that accompany the calibration gas cylinder or generator being used.

Model specific instructions:

Below is information about the calibration of specific Crowcon detectors. This differs between models due to the different interactions of sensors and gas flows in each type.

For calibrating the ozone, the flow plate with four inlets (part number S012976) should be used. The ozone sensor should always be at position 3 as marked on the aspirator plate. Note that the standard flow plate must be used for calibrating the other gas sensors.

VIII. PC interface and software

Tetra can be connected to a PC using an infrared optical link. The Tetra unit has an optical communication port: an IR window is located on the top of the unit. The PC requires a Crowcon infrared PC interface, part number MIS26003 and Crowcon Portables PC software. The adaptor connects to an RS232 port, a USB-RS232 adaptor is also available from Crowcon.

The software provides the user with access to reconfigure alarm levels, operation, run calibrations, print reports and to access the event log.

Set-up

1. Install Portables PC software on PC and install infrared adaptor.

Warning

The infrared communications are not IrDA. **DO NOT install IrDA drivers**, if supplied with with the IR link kit.

2. Switch on the Tetra unit and move to within range of the adaptor.
3. Open the Portables PC software and either use the Wizard or the Engineer's Form, select Tetra and upload the configuration.

For more information on using the Crowcon Portables PC software, see installed help file.

IX. i-module replacement

1. Ensure you are in a non-hazardous (safe) area.
Switch off the unit
2. Remove any accessories, such as the flow adaptor, if fitted.
3. Remove the front cover grille by unscrewing the M3, 2 mm Allen screw as shown the in the drawing, point ①

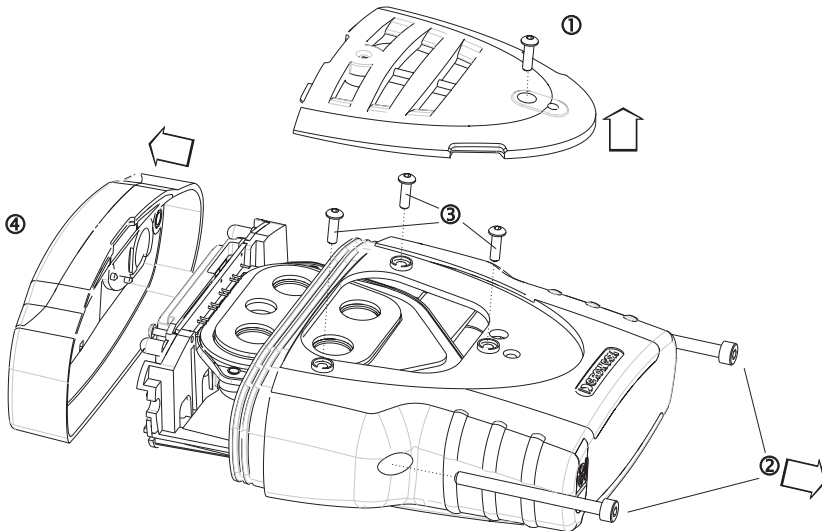

4. Unscrew the side retaining M4, 3 mm Allen screws as shown in ②.
5. Remove the three sensor plate retaining screws as shown by point ③.
6. Ease the top away from the body, point ④.
7. Press down lightly on the rubber seal protecting the sensor housing and slide forward, to clear the internal chassis from the sensor plate aperture. With care, withdraw the whole instrument assembly.

Removing an installed i-module

1. Locate the i-module connection ribbon, squeeze the two retaining lugs, on the module board, toward each other and pull out slightly, this will release the ribbon.
2. Remove the retaining ring from the clips. Unclip the i-module from the

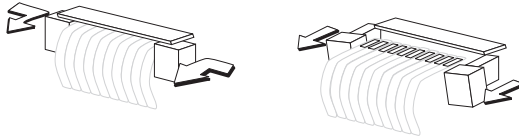

two quick release fixings, push the sensor mounting out of the sensor plate housing, taking care to retain any seals.

Installing or replacing an i-module

If replacing an i-module with one of the same type, instrument specific configuration will be retained. If replacing with a different i-module its default configuration will be loaded.

1. Unwrap the i-module from any packaging, ensure the sensor is fully seated on the module board.
If you are installing a new i-module into a currently unused slot, you will first need to remove the dummy i-module. Follow the i-module removal instructions to do so.
2. Ensure the gasket is in place on the sensor, push the sensor through the sensor aperture in the sensor plate housing. Click the quick release fixings around the i-module board, ensuring the i-module is held in place firmly and the sensor is still tightly located on the module board. Replace the retaining ring on the clips.
3. Attach the ribbon connector by squeezing the two retaining lugs, on the module board, toward each other and pulling out slightly. Slide the ribbon, with the metal connectors facing away from the board, into the slot. Push the retaining lugs back toward the sensor, this will grip the ribbon firmly.

Warning

Do not twist the connection ribbons.
Do not pull the sensor housing assembly too far from the PCB board.
Doing so may damage the cabling or electrical connections.

Re-assembling the Tetra unit

1. Ensure the connection ribbons and cables are tucked in. Slide the whole assembly back into the casing. Ensure all gaskets are in place. Replace the top and front cover grille.
2. Switch on your Tetra unit. The new sensor will be automatically identified.

*Check the filters and gaskets are all in good condition.
Replace if any items are faulty.
Refer to the troubleshooting guide if necessary.*

X. Specification

Dimensions	122 x 128 x 57 mm (4¾ x 5 x 2½ inches)
Weight	498 g rechargeable unit, including belt clip and 4 sensors.
Housing, degree of protection	Ingress protection IP65 (NEMA 4)
Operating temperature	-20°C to +55°C (-4°F to +131°F)
Humidity	0-99% RH, non-condensing for continuous operation
Display	128 x 64 pixel
Warm up time	45 seconds approximately
Response time (typical)	(T90) : approx 20 seconds for most toxic sensors, 10 seconds for oxygen.
Repeatability	±2% FSD, 6 months
Explosion protection	Intrinsically Safe
ATEX	Essential Health and Safety Requirement, clause 15.9
Safety certificate no.	BASEEFA03ATEX0193
Approval codes	
Europe:	ATEX II 2G EEx ia d IIC T4, (Tamb -20°C to +55°C)
USA:	Class I Division 1, Groups A, B, C and D.
Canada:	Class I Division 1, Groups A, B, C and D T4.
Standards	
Safety:	EN50014, EN50020, EN50018, 94/9/EC
USA:	UL913
Canada:	CSA22.2, 152
Operation	EN50270, EN50271, IEC61508
Marine Equipment Directive 96/98/EC	Tetra can be supplied Wheelmarked compliant with the Marine Equipment Directive. Contact Crowcon to obtain a copy of the MED certificate

XI. Accessories and spare parts

Accessory list

Crowcon

part number

Description

C01841	Aspirator Plate and Gasket
C01846	Aspirator assembly for pumped units
C01847	Aspirator assembly, non pumped units
C01876	Tetra Gas Test Accessory Kit for pumped units
C01877	Tetra Gas Test Accessory Kit for non-pumped units. Refer to Section VII for applicability
C01893	Tetra Gas Test Accessory Kit. Refer to Section VII for applicability
C01874	Calibration Flow Plate for pumped units. Refer to Section VII for applicability
C01875	Calibration Flow Plate for non-pumped units. Refer to Section VII for applicability
C011005	Calibration Flow Plate. Refer to Section VII for applicability.
C03365	Quad Gas mixture for Gas Test Accessory Kit, 34 litre bottle 50%LEL methane, 100ppm carbon monoxide, 15ppm hydrogen sulphide, 18% oxygen balance nitrogen. Calibration gas contact Crowcon - required gases depend on sensor combination

Battery charger power supplies

E01839	External PSU for Tetra Charger, UK 230 V 50 Hz
E01866	External PSU for Tetra Charger, US 110 V 60 Hz
E01841	External PSU for Tetra Charger, Euro 230 V 50Hz
E01860	230 V in line charger, no plug fitted.
E01861	110 V in line charger, no plug fitted.

i-modules:

S011424*	0-100% LEL methane
S011436*	0-100% LEL propane
S011437*	0-100% LEL pentane
S011439*	0-100% LEL butane
S011440*	0-100% LEL ethylene

*There are alternative flammable sensors for different applications. Contact Crowcon with the instrument Serial No. to check correct sensor type.

i-modules cont:

S011423	0-25% oxygen O ₂
S011421	0-100 ppm hydrogen sulphide H ₂ S

S011422	0-500 ppm carbon monoxide CO
S011425	0-20 ppm sulphur dioxide SO ₂
S011426	0-10 ppm nitrogen dioxide NO ₂
S011427	0-20 ppm nitrogen dioxide NO ₂
S011428	0-20 ppm chlorine Cl ₂
S011429	0-1000 ppm hydrogen H ₂
S011430	0-25 ppm hydrogen cyanide HCN
S011431	0-5 ppm phosphine PH ₃
S011432	0-1 ppm ozone O ₃
S011433	0-10 ppm hydrogen fluoride HF
S011434	0-1 ppm fluorine
S011435	0-100 ppm ammonia NH ₃
S011438	0-1000 ppm ammonia

Sampling accessories:

C01847	Aspirator assembly for non pumped units
C01757	Telescopic aspirator probe
C01097	3 foot Sample probe
M04032	Aspirator hose (please specify length in feet)
C03141	6 m Drop line
C01245	Water trap

Carrying and wearing:

C01842	Universal harness plate
C01843	Shoulder strap
C01844	Chest harness strap kit
C01845	Carry case, rechargeable units
C01888	Carry case, non-rechargeable units

Communications:

MIS26003	Infrared adaptor for PC, plugs into RS232 port
C02097	USB to RS232 adaptor
C01832	Portables PC Software CD

Spares / consumables:

E01541	Alkaline battery, AA (3 required)
S011330	Rechargeable Li-ion battery pack assembly
C01851	Aspirator bulb
S011398	Sensor filter assembly
C01853	Dummy sensor module
M04787	Rubber sealing bung for charger socket
M04482	i-module O-ring seal
M04431	Sensor clip retaining ring

For calibration gases consult Crowcon

XII. Troubleshooting guide

Symptom/ error message	Cause	Action
Instrument won't switch on	Flat battery.	Recharge or replace battery.
Pump not running	The pump is a PC configurable option.	Reconfigure with PC software.
No confidence beep	Function disabled.	Reconfigure with PC software.
Gas reading when no gas present	Zero drifted.	Restart instrument in clean air.
Unstable/inaccurate gas reading	Sensor failure	Do not use; exit hazardous area immediately. Return instrument for recalibration or sensor replacement.
Autozero failed	Zeroing in contaminated atmosphere	Switch off and restart in clean air.
Cannot autozero due to alarm	Zeroing in contaminated atmosphere	Switch off and restart in clean air
Calibration expired	The calibration due date has passed	Send for calibration
Flow fail clear blockage	Sample tube is blocked with water or dirt or kinked	Clear blockage and press button to restart pump
LCD too faint/dark	Contrast setting wrong	Adjust using Portables PC software.



Fatal/Auto shut



Service



User alert



Calibration



Configuration

Appendix: Limitations of sensors

Sensor limitations

The sensors used in Tetra have limitations common to all such gas sensors, and users should be aware of the points listed below. Crowcon can advise on particular situations and suggest alternative sensors if the instrument is likely to experience extreme conditions.

Tetra uses a catalytic flammable gas sensor, which measures the flammability of the gas. For this reason, readings displayed on the unit will be unreliable over concentrations of approximately 120% LEL. Oxygen is necessary for catalytic sensors to operate. A 'pellistor saver' is used to disconnect power to the pellistor sensor in the event of over-range to prevent burn out. This locks out for 200 seconds after which a button press will reconnect power to the pellistor. If the sensor power is reconnected when the unit is exposed to an over-range gas concentration there is a risk of damage to the pellistor sensor. Restart should be carried out in a known fresh air environment. Depleted oxygen levels can reduce the flammable gas reading, and if oxygen levels are below safe breathing limits it should be assumed that the flammable reading is low.

Electrochemical gas sensors contain chemicals. Extreme levels of humidity can also cause problems. The sensors are rated for an (average) ambient of 15-90% R.H. However they are used from the tropics to deserts to tundra without this normally being a problem.

Water should not be allowed to collect on the sensors as this may impede gas diffusion.

Persistent exposure to high levels of toxic gas will shorten the life of toxic sensors. If the high level gas is corrosive (e.g. hydrogen sulphide) damage may occur over time to metal components.

Sensors may be cross sensitive to other gases. If unsure, contact Crowcon or your local agent.

A HALMA COMPANY



www.thorneandderrick.com

