**User's
Manual**

**Model OX400
Low Concentration Zirconia
Oxygen Analyzer
[Style: S2]**



IM 11M10B01-01E

vigilantplant.[®]

INTRODUCTION

■ Safety, Protection, and Modification of the Product

- In order to protect the system controlled by the product and the product itself and ensure safe operation, observe the safety precautions described in this user's manual. We assume no liability for safety if users fail to observe these instructions when operating the product.
- If this instrument is used in a manner not specified in this user's manual, the protection provided by this instrument may be impaired.
- If any protection or safety circuit is required for the system controlled by the product or for the product itself, prepare it separately.
- Be sure to use the spare parts approved by Yokogawa Electric Corporation (hereafter simply referred to as YOKOGAWA) when replacing parts or consumables.
- Modification of the product is strictly prohibited.
- The following symbols are used in the product and user's manual to indicate that there are precautions for safety:



■ Notes on Handling User's Manuals

- Please hand over the user's manuals to your end users so that they can keep the user's manuals on hand for convenient reference.
- Please read the information thoroughly before using the product.
- The purpose of these user's manuals is not to warrant that the product is well suited to any particular purpose but rather to describe the functional details of the product.
- No part of the user's manuals may be transferred or reproduced without prior written consent from YOKOGAWA.
- YOKOGAWA reserves the right to make improvements in the user's manuals and product at any time, without notice or obligation.
- If you have any questions, or you find mistakes or omissions in the user's manuals, please contact our sales representative or your local distributor.

■ Warning and Disclaimer

The product is provided on an "as is" basis. YOKOGAWA shall have neither liability nor responsibility to any person or entity with respect to any direct or indirect loss or damage arising from using the product or any defect of the product that YOKOGAWA can not predict in advance.

■ Notes on Hardware

● Appearance and Accessories

Check the following when you receive the product:

- Appearance
- Standard accessories

Contact our sales representative or your local distributor if the product's coating has come off, it has been damaged, or there is shortage of required accessories.

● Model and Suffix Codes

The name plate on the product contains the model and suffix codes. Compare them with those in the general specification to make sure the product is the correct one. If you have any questions, contact our sales representative or your local distributor.

■ Symbol Marks

Throughout this user's manual, you will find several different types of symbols are used to identify different sections of text. This section describes these icons.



WARNING

Identifies instructions that must be observed in order to avoid physical injury and electric shock or death of the operator.



CAUTION

Identifies instructions that must be observed in order to prevent the software or hardware from being damaged or the system from becoming faulty.



NOTE

Identifies important information required to understand operations or functions.

■ About Unique Representations Used in this Operation Manual

When operation keys, contents displayed on the display, and lamp displays are specifically described in the text or anywhere else in this operation manual, in principle, they are represented in the following ways.

- Operation key

Represented by []. Example: [ENT] key

- Display contents on the display

Represented by “ ”. Example: Main display --> “HEAt”

Example: Sub-display --> “CAL”

Example: Data display --> “10.00” (in the ON state)

Example LED lamp --> ● PPM (in the ON state), ○ PPM (in the OFF state)

- Graphical representation of the flashing state

Represented by italic characters or the  mark.

Flashing state

1.000

Flashing state of decimal point

1.000

- Representation of digital characters

The OX400 employs a 7-segment alphanumeric digital display. For the correspondence between the display characters on the display and alphanumeric characters for explanation, see Figure 5.2.

■ Operation Parameters

The OX400 is shipped with default parameters as shown in Table 8.1. Change them according to the purpose of use. For how to change parameters, see Chapter 6, “Operation and Parameters.” It is recommended to write down the changed operation parameters as user set values as shown in Table 8.1.

■ Notes on Use

The OX400 is a product that conforms to the general safety requirements of the IEC standard. Be sure to observe the following precautions when you operate it.



Handling Precautions

- Installation location
The OX400 is structurally non-explosion proof so you cannot use it in an explosive atmosphere. Also, see 3.1, “Installation Location.”
- Power supply
Be sure to check that the power supply voltage specification of the OX400 matches the voltage of the power supply before turning on the power.
- Protective ground
Be sure to connect the power plug of the OX400 to the 3P socket with a protective ground pin in order to prevent electric shock.

- Fuse
Be sure to use a designated fuse in order to prevent a fire. Be sure to turn off the power before replacing the fuse. Never use a fuse holder other than a designated one.
- Removing cover
There is a heated area inside the OX400, and touching it directly may cause a burn injury. Never remove the cover except to replace the sensor.
- When opening the cover to replace the sensor, turn off the power switch, remove the power plug from the socket, and wait for 1.5 hours or more before opening the cover.
- Before connecting wires to the terminal block on the rear panel of the OX400, remove the power plug from the socket in order to prevent electric shock. After finishing the wiring, secure the removed special terminal cover with screws.
- The OX400 is a measuring instrument intended to be installed indoors, so do not install it in a location that is exposed to direct sunlight, rain, and wind.
- Do not use the OX400 in a location that may be subject to vibrations and impact. Doing so may cause destruction and damage to the internal sensor.
- Do not apply a pressure of 30 kPaG or more to the gas inlet. Doing so may cause destruction of the suction pump and damage to the sensor. Be sure to reduce the sample gas pressure to the atmospheric pressure level before introducing the gas.
- Be sure to use metal piping for the gas piping; particularly when handling oxygen concentration in 1 vol % or less. Use of piping materials such as polyethylene, vinyl, rubber, and plastic may cause significant errors in measurements because of their large oxygen transmission and absorption rates.
- The presence of corrosive gas components (H₂S, SO_x, HCl, NH₃, HF, and the like) or potentially toxic elements (Si, Sn, Cd, Te, As, P, and the like) in the sample gas may cause deterioration of the sensor. Be sure to remove them with an activated carbon filter or the like in the previous step of the OX400 before introducing the gas.
- The presence of combustible gas in the sample gas may cause errors in measurements because oxygen in the sample gas will be consumed by combustion. Be sure to remove it with a filter or the like in the step before introducing the sample gas into the OX400.
- Make sure the temperature of the sample gas is 50°C or less.
- Be careful because the presence of water droplets in the sample gas may cause damage to the sensor.
- Keep the supply gas flow rate and pressure as constant as possible while introducing the gas.
- Keep the sample gas outlet open to the atmosphere during operation. If a gas line must be used to discharge gas, use a gas line with a connector that has the largest possible diameter in order to prevent back pressure.
- Do not use the supplied power cord with another device.
- Power cable suffix codes of “-D” can be used in Japan, because another cable doesn’t conform to PSE marking.

◆ After-sales Warranty

- Do not modify the product.

- During the warranty period, for repair under warranty carry or send the product to the local sales representative or service office. Yokogawa will replace or repair any damaged parts and return the product to you. Before returning a product for repair under warranty, provide us with the model name and serial number and a description of the problem. Any diagrams or data explaining the problem would also be appreciated.
 - If we replace the product with a new one, we won't provide you with a repair report.
 - Yokogawa warrants the product for the period stated in the pre-purchase quotation Yokogawa shall conduct defined warranty service based on its standard. When the customer site is located outside of the service area, a fee for dispatching the maintenance engineer will be charged to the customer.

- In the following cases, customer will be charged repair fee regardless of warranty period.
 - Failure of components which are out of scope of warranty stated in instruction manual.
 - Failure caused by usage of software, hardware or auxiliary equipment, which Yokogawa Electric did not supply.
 - Failure due to improper or insufficient maintenance by user.
 - Failure due to modification, misuse or outside-of-specifications operation which Yokogawa does not authorize.
 - Failure due to power supply (voltage, frequency) being outside specifications or abnormal.
 - Failure caused by any usage out of scope of recommended usage.
 - Any damage from fire, earthquake, storms and floods, lightning, disturbances, riots, warfare, radiation and other natural changes.

- Yokogawa does not warrant conformance with the specific application at the user site. Yokogawa will not bear direct/indirect responsibility for damage due to a specific application.

- Yokogawa Electric will not bear responsibility when the user configures the product into systems or resells the product.

- Maintenance service and supplying repair parts will be covered for five years after the production ends. For repair for this product, please contact the nearest sales office described in this instruction manual.

Model OX400
Low Concentration Zirconia Oxygen Analyzer
[Style: S2]

IM 11M10B01-01E 4th Edition

CONTENTS

INTRODUCTIONi

◆ After-sales Warrantyv

1. Outline 1-1

2. Specifications 2-1

 2.1 Standard Specifications..... 2-1

 2.2 Characteristics 2-3

 2.3 Model and Suffix Codes 2-4

 2.4 Standard Accessories 2-4

 2.5 External Dimensions 2-5

 2.6 Piping Diagram..... 2-10

 2.7 Wiring Diagram..... 2-11

3. Installation..... 3-1

 3.1 Installation Location 3-1

 3.2 How to Install 3-2

 3.2.1 Installing Desktop Type..... 3-2

 3.2.2 Installing Panel Mount Type..... 3-3

 3.2.3 Mounting Activated Carbon Filter..... 3-4

4. Piping and Wiring 4-1

 4.1 Piping 4-1

 4.2 Wirings 4-2

 4.2.1 Power Supply Wiring..... 4-2

 4.2.2 Signal Wiring 4-3

 4.2.3 Communication 4-5

5. Names and Functions 5-1

 5.1 Front Panel 5-1

 5.2 Rear Panel..... 5-3

6. Operation and Parameters 6-1

 6.1 Startup and Settings..... 6-2

 6.1.1 Setting Output Range “rnG” 6-2

 6.1.2 Setting Secondary Output “oUt2” 6-4

 6.1.3 Setting HOLD Function “HoLd” 6-4

 6.1.4 Setting Burnout Function “nAMU” 6-5

 6.1.5 Setting Alarms (Oxygen Concentration High/Low Alarms) “ALM” 6-6

6.1.6	Setting Calibration Gas Concentration “SEt.C”	6-7
6.1.7	Setting Sensor Constant “SEnS”	6-7
6.1.8	Setting Output Smoothing “SMoo”	6-8
6.1.9	Setting Multi-Selector “MLS”	6-8
6.1.10	Checking Calibration Coefficient “CoEF”	6-8
6.1.11	Displaying Cell Resistance Value “CEL.r”	6-9
6.1.12	Displaying Software Revision “rEV”	6-9
6.2	Calibration “CAL”	6-10
6.3	Communication.....	6-12
6.4	Measurement Gas Sampling Using Aspirator	6-14
6.5	Switching Measurement Flow Path Using Multi-Selector	6-15
6.6	Numerical Value, Decimal Point, and Unit Input Operation	6-16
7.	Inspection and Maintenance	7-1
7.1	Routine Inspection and Maintenance	7-1
7.2	Inspection in the Event of an Error	7-1
7.2.1	Inspection in the Event of an Alarm (ALM)	7-2
7.2.2	Inspection in the Event of an Error (ERR).....	7-2
7.3	How to Replace Sensor	7-3
7.3.1	Removing Sensor	7-3
7.3.2	Installing Sensor	7-5
7.4	How to Replace Activated Carbon Filter	7-7
7.5	How to Replace the Line Filter.....	7-8
8.	Appendix	8-1
8.1	Parameter Settings	8-1
	Customer Maintenance Parts List (Style: S2)	CMPL 11M10B01-02E
	Revision Information	i

1. Outline

The OX400 is a highly accurate and reliable low concentration zirconia oxygen analyzer that is capable of measuring a wide range of concentrations, from 0-10 ppm up to 0-100 vol% O₂. This is the latest oxygen analyzer from Yokogawa, and its development was based on the company's long experience and strong track record with this technology.

A proprietary new thin-film deposition technology was used in the zirconia sensor that creates a molecular bond between the zirconia element and the platinum layer. This prevents separation, enables a reduction in sensor size and ensures a high-speed response and long life.

The OX400 can be used to control and monitor various semiconductor applications, and to control environment, air leakage into inert gas, and other processes.

Features

Long life and high-speed response

- Thanks to the use of Yokogawa's proprietary new thin-film deposition technology, the sensor has three times the lifespan of those used in our earlier products.
- A cylindrical sensor design facilitates the replacement of measurement gases, thereby helping to assure a high-speed response.

High performance and high reliability

- Superior repeatability and linearity even at low oxygen concentrations
- Either pump or aspirator sampling can be selected, depending on the application.

Built-in functions and a variety of self-diagnosis functions

- Comes with multi selector, auto range, partial range, and pump on/off functions
- A variety of self-diagnosis functions are provided that detect malfunctions such as heater temperature error, temperature sensor burnout, and sensor resistance value error.

Superior maintainability

- The sensor can be replaced on-site.
- Compact and lightweight for easy installation.

Applications

- Oxygen concentration control in semiconductor-related diffusion and drying furnaces and in LCD manufacturing processes
- Oxygen concentration control in solder pot flow and re-flow ovens, and glove boxes used in electronics manufacturing, and in gas production processes
- Oxygen concentration measurements to prevent dust explosions during powder transfer

Blank Page

2. Specifications

2.1 Standard Specifications

Measurement object

: Oxygen concentrations in inert gases containing no flammable gas, silica, corrosive gas, or liquid (including water vapor).

Measurement system: Zirconia system

Sampling method: Pump, aspirator, or no suction device.

Pump and aspirator suction flow rate

: Approx. 1.0 L/min.

Aspirator suction conditions

: Air or N₂, supply pressure 65 to 100 kPaG, total discharge flow 10 L/min max. (when gas inlet and outlet are at ambient atmospheric pressure).

Sample gas conditions

Flow rate : 200 ± 25 mL/min (only applies to sensor).

Temperature : 0-50°C (non-condensing).

Humidity : Non-condensing.

Pressure : 0-300 PaG

Measurement range: 0-10 ppm O₂ to 0-100 vol% O₂.

Resolution: 0.01 ppm O₂.

Display: 4 digit LED.

Main display: O₂ concentration (auto switching).

Sub display: Parameter or alarm/error number

Unit : %, ppm.

Output range

Auto : 0-10 ppm, 0-100 ppm, 0-1000 ppm, 0-1%, 0-10%, 0-100% (default)
Other : 0-□ ppm, 0-□00 ppm, 0-□000 ppm, 0-□%, 0-□0% can be set,
□ is an integer from 2 to 9.

Fixed : Set to 0-10 ppm, 0-100 ppm, 0-1000 ppm, 0-1%, 0-10%, or 0-100%.

Partial : Lower value or upper value of range can be set.

Note : Span (upper value-lower value) is 20% FS or more of above fixed range.

Example: 200-400 ppm when fixed range is 0-1000 ppm, 20-40 ppm when fixed range is 0-100 ppm.

Analog output: 2 outputs

Primary : 4 to 20 mA DC (maximum load resistance: 550Ω)

Secondary : Select from 0-1, 0-5, 0-10 V DC (load resistance: 10 kΩ or greater)

Contact output: 3 outputs

Error contact, O₂ concentration high/low alarm contact, range marker output

Multi selector (optional)

: Contact output for switching sample gas flow, measurement flow information contact output.

Note : For details , see external dimensions.

Contact output specifications

General : Relay

Nominal contact capacity:

2 A 30V DC, 2 A 240 V AC (120 V AC for 100 V power supply) for resistive load

Maximum power: 60 W, 480 VA

Maximum voltage: 30 V DC, 264 V AC (132 V AC for 100 V power supply)

Maximum current: 2 A DC/AC

Contact input: Voltage-free contact, 1 point

: Remote switching for sample gas suction pump ON/OFF

Self-diagnostics

Error (failure) : Sensor unit error, heater temperature error, temperature sensor disconnection, device temperature error, CPU error, fan stop.

Alarm (warning) : Heater unstable, sensor defect, electromotive force abnormal, asymmetry voltage error, calibration error, sensor resistance error, O₂ concentration upper/lower, over range.

Serial communication

Comm. signal : RS-232 , one way

Baud rate : 38,400 bps

Data (ASCII) : O₂ concentration, unit, alarm/error

Calibration methods:

(1) 3 point: 10 ppm, 1000 ppm, Air

(2) 2 point: zero and span calibration may be set freely

(3) 1 point:

(4) Air calibration

Warm-up time : Within 20 min

Power supply:

Power supply : 100 - 120 V AC/200 - 240 V AC, 50/60 Hz

Acceptable range: 100 to 120 V AC \pm 10%, 50/60 Hz

200 to 240 V AC \pm 10%, 50/60 Hz

Power consumption

: 100 to 120 V AC, 200 VA max.

200 to 240 V AC, 400 VA max.

Dimensions : 213 (W) x 132 (H) x approx. 375 (D) mm

Weight : Approx. 5 kg

Finish : Polyester coating

Line connection

Gas inlet : Rc1/4 or 1/4NPT female

Gas outlet : Rc1/4 or 1/4NPT female

Electrical connection

External output terminals: M3 screw

Contact input/output terminals: M3 screw

Serial communication: D-sub 9 pin connector

Ground: within power cord connector

Environment and operational conditions

Installation conditions: Indoors, panel or wall mounting, non explosion area

Ambient temperature: 0 to 40°C, non-condensing

Ambient humidity: 5 to 85% RH

Storage temperature: -5 to 50°C

Conformance to Safety and EMC standards   

Safety : EN 61010-1

CAN/CSA-C22.2 No. 61010-1-04, UL Std. No. 61010-1

EMC: EN 61326-1 Class A, Table 2 (for use in industrial locations)(*1)

EN 61326-2-3, EN 61000-3-2, EN 61000-3-3

KC Marking: Korea Electromagnetic Conformity Standard

*1: Influence of immunity environment (Criteria A): $\pm 20\%$ of F.S.

Note1: This instrument is a Class A product, and it is designed for use in the industrial environment. Please use this instrument in the industrial environment only.

Note2: The current or voltage signal output cable length and contact input cable length must be no longer than 30 m for CE marking. RS232 connection cable length must be no longer than 3 m.

Installation altitude: 2000 m or less

Category based on IEC 61010: II (Note)

Pollution degree based on IEC 61010: 2 (Note)

Note: Installation category, called over-voltage category, specifies impulse withstand voltage. Category II is for electrical equipment. Pollution degree indicates the degree of existence of solid, liquid, gas or other inclusions which may reduce dielectric strength. Pollution degree 2 is the normal indoor environment.

2.2 Characteristics

Repeatability

: $\pm 1\%$ FS (Hereafter, either 10, 100, 1000 ppm, 1%, 10%, or 100% O₂ is FS)

Linearity

: $\pm 2\%$ FS

$\pm 3\%$ FS (0-100 ppm or less)

Response time : 90% response

: Within 10 sec (0-1% or more)

: Within 30 sec (less than 0-1%)

Drift

: $\pm 2\%$ FS / week

2.3 Model and Suffix Codes

[Style: S2]

Model	Suffix Code	Option Cord	Description
OX400	Low Concentration Zirconia Oxygen Analyzer
Power supply (*1)	-5 -3	100-120 V AC 200-240 V AC
Sampling method	-P -A -N	Built-in pump With aspirator No suction device
Line connection	R T	Rc 1/4 1/4 NPT
User's manual	-J -E	Japanese English
Power cable (*1)	-D -F -H -Q -R	UL/CSA cable (2 m) VDE cable (2.5 m) GB cable (2.5 m) BS cable (2 m) SAA cable (2.5 m)
Option	Mounting hardware Multi selector function Filter	/P /MS /A	Panel mount Multi selector function Activated carbon filter (*2)

- *1: Power cable of two-pole with earthing plug is attached.
Suffix code "-D" of power cable can not be specified when "-3" of power supply is specified.
Power cable of "-D" can be used in Japan, because another cable doesn't conform to PSE marking.
- *2: When "R" of line connection is specified, K9643KH filter (Rc1/4) is attached, when "T" of line connection is specified, K9643KJ filter (1/4NPT) is attached.
"/A" is specified when it is used for flow furnace or reflow furnace.

2.4 Standard Accessories

Check the standard and optional accessories when you receive the product.

Accessories

Item	Part no. and rating	Qt'y
Fuse	A1113EF: Time-lag T3.15 conformed to IEC60127	1
User's manual	IM 11M10B01-01E (English), -01 (Japanese)	1
Aspirator kit	K9643KA (Rc1/4), K9643KB (1/4NPT)	Optional
Panel mount kit	K9643KC	Optional
Activated carbon filter	K9643KH (Rc1/4), K9643KJ (1/4NPT)	Optional

Consumables

Item	Part no. and rating	Qt'y
Activated filter element kit (15 times replacement)	K9643KK	1
Filter kit (5 times replacement)	K9643KL	1
Sensor assembly (including O-ring)	K9643KG	1
Snap ring (retainer)	Y9011EV	1 (*1)
Plate	K9213FB	1 (*1)
Filter	K9643FB	1
Snap ring plier	K9643ZE	1

- *1: Qt'y of 10 pieces or more can be purchased.

Desktop type with built-in pump or no suction device (OX400-□-□□-□-□)

Unit: mm

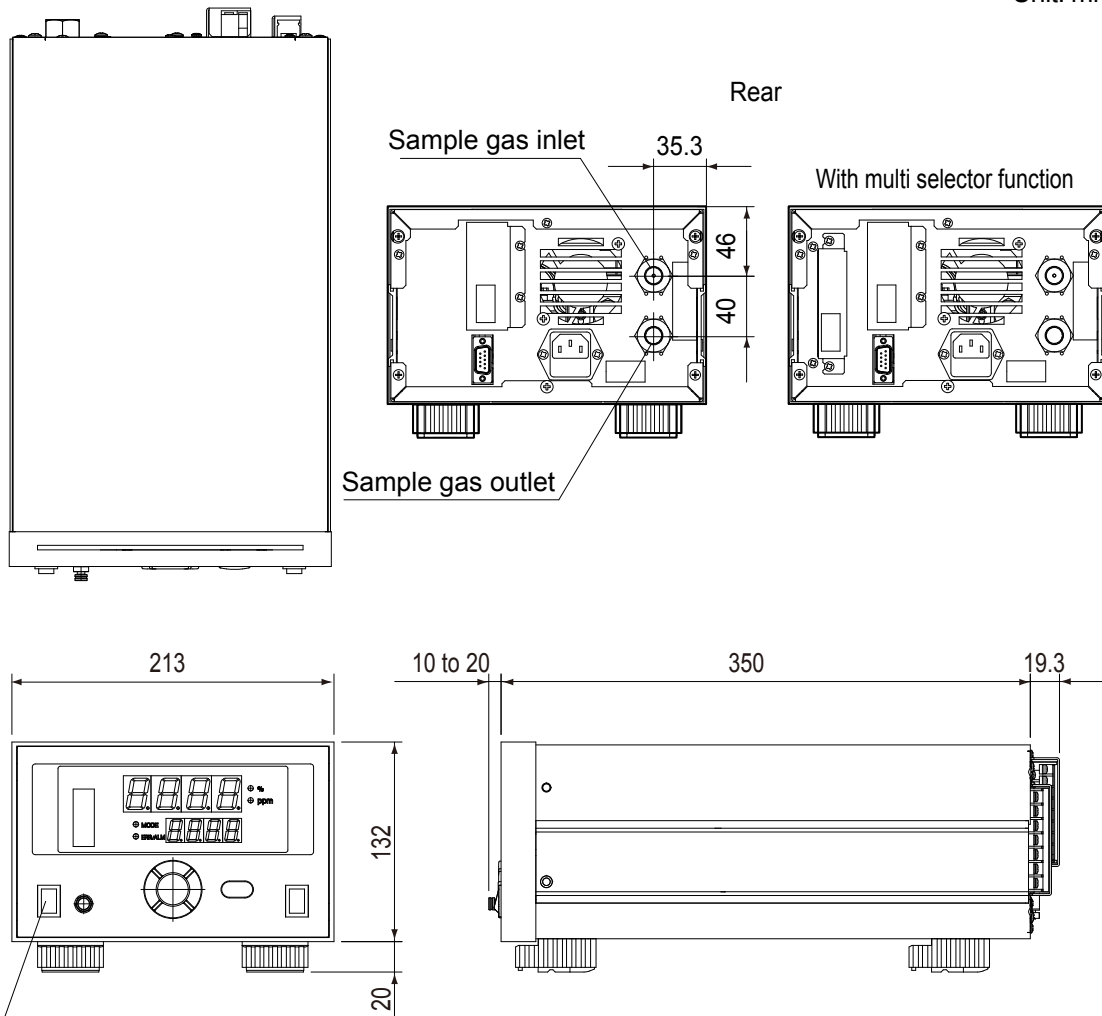

Note: Pump ON/OFF switch; when no suction device [-N] is specified for the sampling method, this switch is not installed.

Notes on installation

Hot air is discharged from the air outlet on the rear panel of the OX400. Maintain at least 100 mm of free space around the OX400 to ensure adequate ventilation.

Desktop type with aspirator (OX400-□-A□-□-□)

Unit: mm

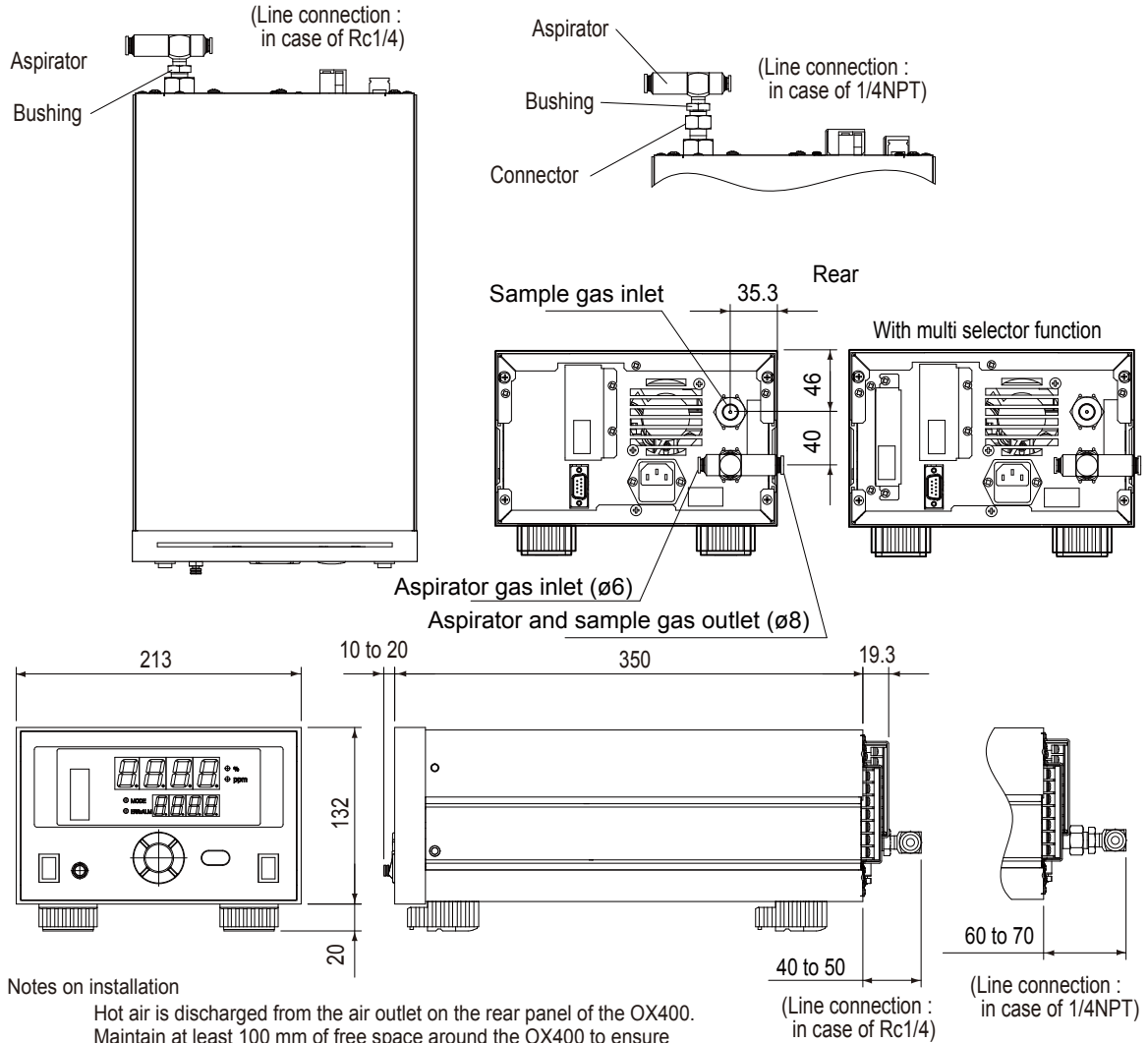

Notes on installation

Hot air is discharged from the air outlet on the rear panel of the OX400. Maintain at least 100 mm of free space around the OX400 to ensure adequate ventilation.

Activated carbon filter

Unit: mm

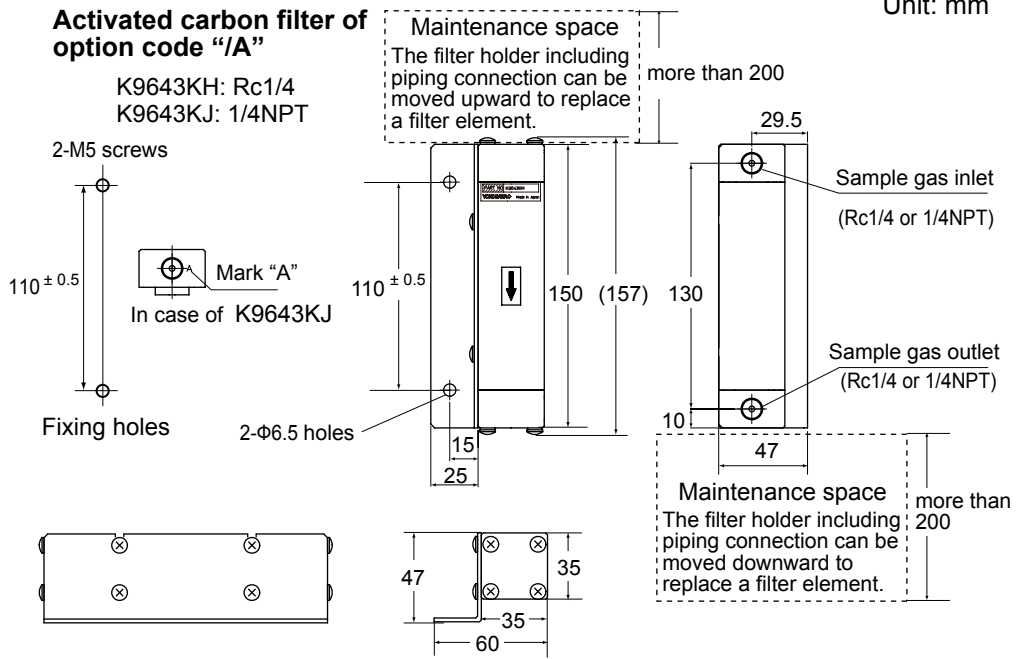

2.6 Piping Diagram

Built-in pump (Sampling method [-P])

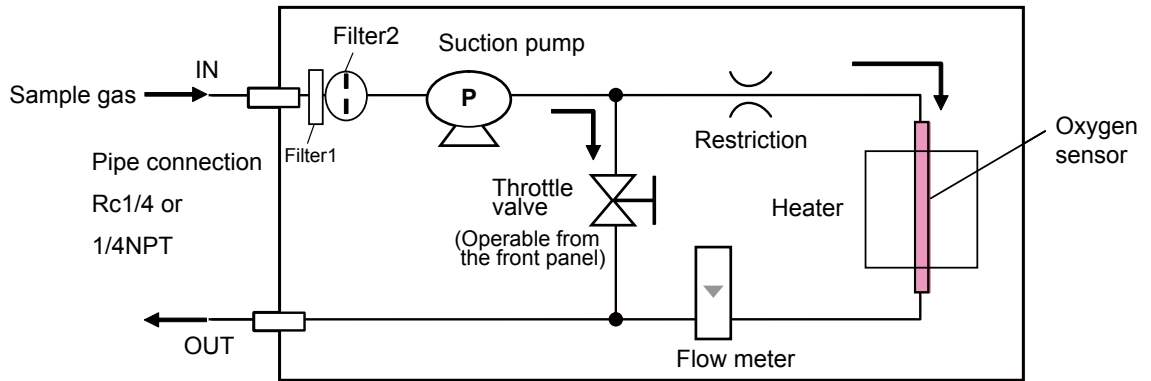

With aspirator (Sampling method [-A])

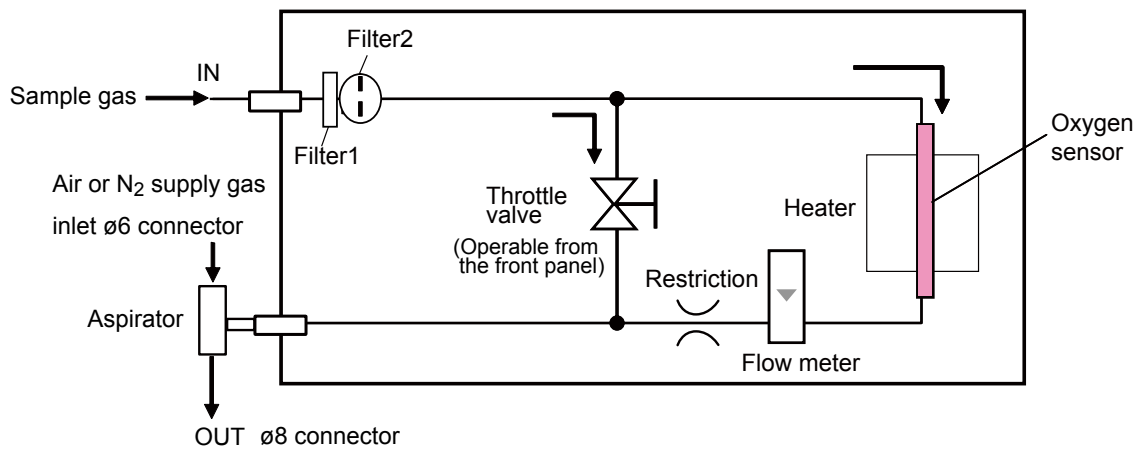

Note: If no suction device [-N] is specified, the aspirator is removed from this diagram.

2.7 Wiring Diagram

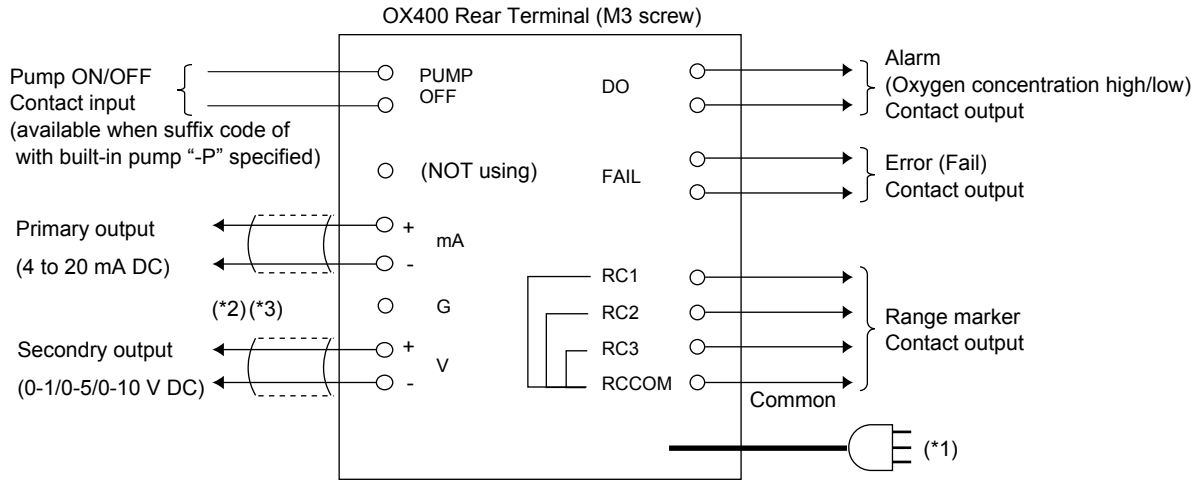

- *1: Use the earthing contact of power cord to ground to earth.
Use the supplied power cord only.
- *2: Ground the measurement output signal line shield on the receiving side.
The G-terminal is connected to a ground pin. Use this if the line shield cannot be grounded on the receiving side.
Be very careful not to ground the line at two points.
- *3: The signal output and contact input cable must be no longer than 30 m for CE marking.
RS232 cable must be no longer than 3 m.

The following terminals are added for the multi-selector "/MS" option.
The customer needs to supply a switching device and carry out the necessary wiring.

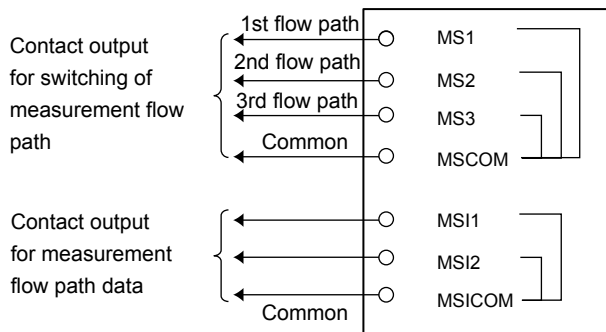

Blank Page

3. Installation

3.1 Installation Location

The OX400 is a measuring instrument intended to be installed indoors. Install and operate it in a location that meets the following conditions in order to ensure the best performance.

- (1) Location where there is no corrosive gas.
- (2) Indoor location where there is no mechanical vibration.
- (3) Location that is not exposed to direct sunlight and radiant heat.
- (4) Location that is free of dust and dirt particles.
- (5) Location with a room temperature of 0 to 40°C and no condensation.



WARNING

Never use the OX400 in an explosion hazardous area. Doing so may cause a fire, explosion, or the like.

- The OX400 is a measuring instrument intended to be used indoors. Do not install it in a location that is exposed to direct sunlight, wind, and rain.
- Do not use the OX400 in a location that may be subject to vibrations and impact. Doing so may cause destruction and damage to the internal sensor.
- Do not apply a pressure of 30 kPaG or more to the gas inlet. Doing so may cause destruction of the suction pump and damage to the sensor. Be sure to reduce the sample gas pressure to the atmospheric pressure level before introducing it.
- Be sure to use metal piping for the gas piping; particularly when handling oxygen concentration in 1 vol % or less. Use of piping materials such as polyethylene, vinyl, rubber, and plastic may cause significant errors in measurements because of their large oxygen transmission and absorption rates.
- The presence of corrosive gas components (H₂S, SO_x, HCl, NH₃, HF, and the like) or potentially toxic elements (Si, Sn, Cd, Te, As, P, and the like) in the sample gas may cause deterioration of the sensor. Be sure to remove them with an activated carbon filter or the like in the previous step of the OX400 before introducing the gas.
- The presence of combustible gas in the sample gas may cause errors in measurements because oxygen in the sample gas will be consumed by combustion. Be sure to remove it with a filter or the like in the previous step of introducing the sample gas into the OX400.
- Make sure the temperature of the sample gas is 50°C or less.
- Be careful because the presence of water droplets in the sample gas may cause damage to the sensor.
- Keep the supply gas flow rate and pressure as constant as possible while introducing the gas.
- Keep the sample gas outlet open to the atmosphere during operation. If a gas line must be used for discharge gas, use a gas line with a connector that has the largest possible diameter in order to prevent back pressure.

3.2 How to Install

3.2.1 Installing Desktop Type

Place and operate the OX400 on a level surface as shown in Figure 3.1.

- (1) Provide a distance of 100 mm or more behind the OX400 in order to not block the outlet of the cooling fan on the rear panel.
- (2) The air inlet of the cooling fan is located on the bottom panel of the OX400. Be sure to provide a distance from the installation surface (desktop) larger than that of the height of the legs of the OX400.

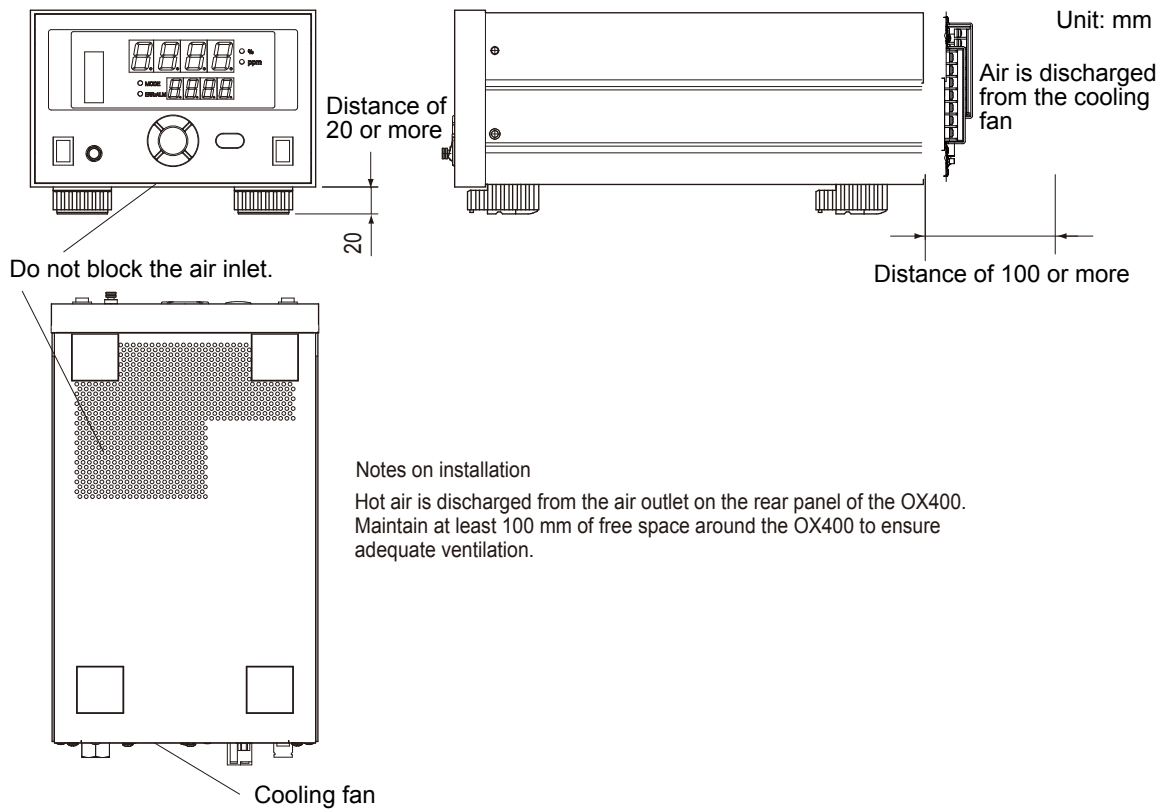
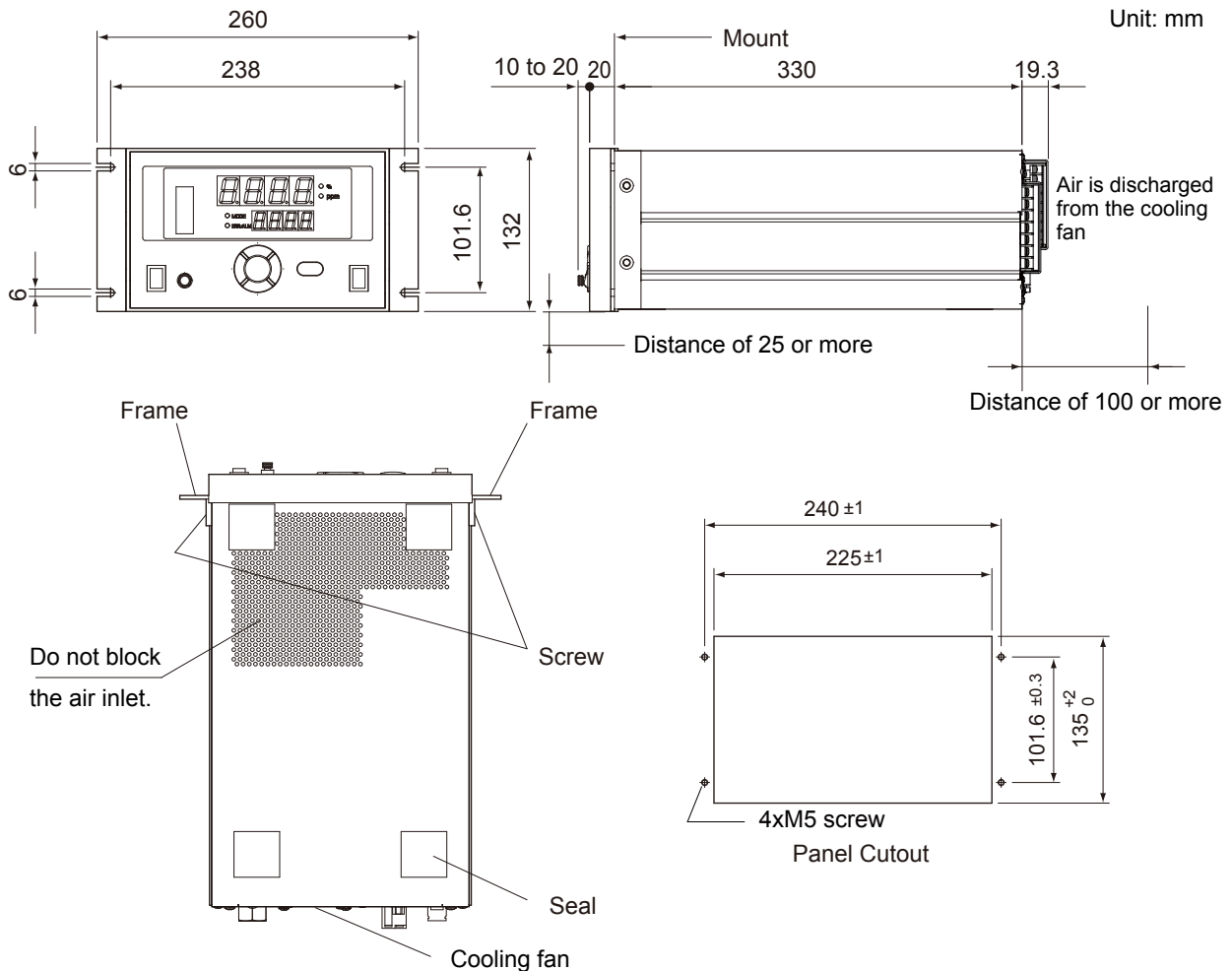

Figure 3.1 Notes on Installing Desktop Type

3.2.2 Installing Panel Mount Type

- (1) Attach a panel mount frame to the side of the OX400, insert it into the panel, and securely screw it to the panel.
- (2) Provide a distance of 100 mm or more behind the OX400 in order to not block the outlet of the cooling fan on the rear panel.
- (3) The air inlet of the cooling fan is located on the bottom panel of the OX400. Be sure to provide a distance of 25 mm or more from the bottom panel in order to not block the bottom panel of the OX400.



Notes on mounting

- 1. Make sure the bottom supports do not block the ventilation outlet on the bottom panel of the measuring instrument.
- 2. Maintain at least 100 mm of free space around the measuring instrument in order to ensure adequate ventilation.
- 3. Make sure the panel is at least 2 mm thick.

Figure 3.2 Notes on Mounting Panel Mount Type

3.2.3 Mounting Activated Carbon Filter

Mount the filter on a panel or wall. To fix the filter with M5 screws. When replace a filter pack, 200 mm or more of maintenance space is necessary. If necessary, the piping connection should be removable.

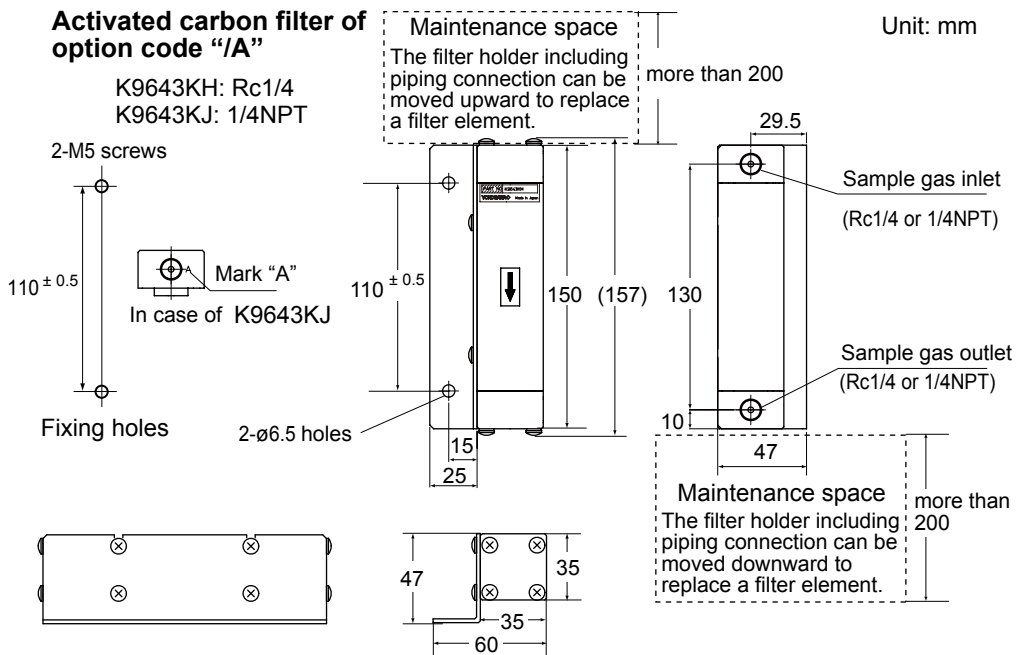

Figure 3.3 Mounting Activated Carbon Filter



NOTE

The activated carbon filter used in this equipment have limited life, and periodic maintenance or replacement will be required. Install this equipment in an accessible location to facilitate maintenance.

Maintenance conditions vary depending on the gas conditions. Replacement intervals for the filter and activated carbon should be determined in accordance with the operating conditions.

- Activated carbon filter life is about 50 hours. (if measured gas contains isopropyl alcohol of concentration 500 ppm, and flow is 500 mL/min.)
- In case of using the built-in pump or with the aspirator, the activated carbon filter life is about 25 hours.

4. Piping and Wiring

4.1 Piping

Be sure to observe the following precautions when connecting the gas pipe to the OX400.

- (1) The connections for both the gas inlet and outlet are Rc1/4 or 1/4NPT. Use the specified thread and securely connect the gas pipe so that no leakage will occur.

WARNING

When screwing in the pipe, be sure to hold the inlet hexagonal part in place with a wrench or the like. Not doing so and using a strong force when screwing in the pipe may cause the thread on the OX400 to rotate, resulting in damage to the internal pipe.

- (2) With respect to piping, use a metal pipe. Use of materials such as plastic, vinyl, rubber, and the like may result in inaccurate measurements due to the transmission of oxygen from the air and absorption onto the inside surface of the pipe. Particularly with respect to silicon tube, be careful because due to its large oxygen transmission rate, accurate measurements cannot be performed in the low concentration range.
- (3) Be careful of leakage from the pipe because it may cause measurement errors. Particularly in the low concentration range, take great care because even though the pressure inside the pipe is positive, oxygen may flow from the air due to diffusion, resulting in a large error.
- (4) Fluctuations of back pressure at the pipe outlet may cause measurement errors, so always keep the pressure at the atmosphere pressure level as much as possible during operation.

Built-in pump (Sampling method [-P])

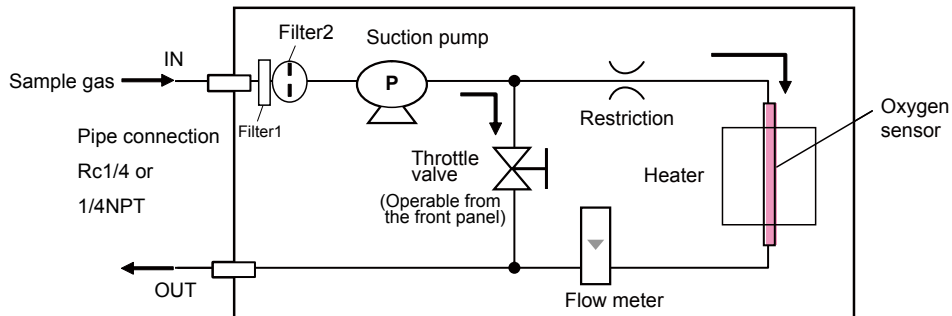

With aspirator (Sampling method [-A])

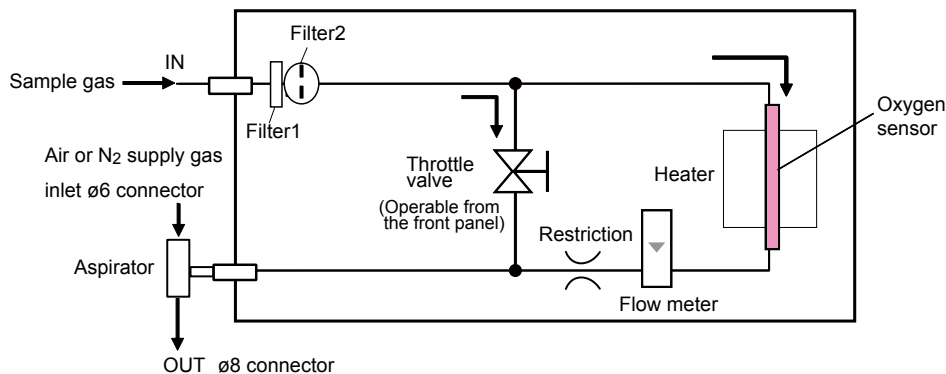

Note: If no suction device [-N] is specified, the aspirator is removed from this diagram.

Figure 4.1 Piping Flow Diagram

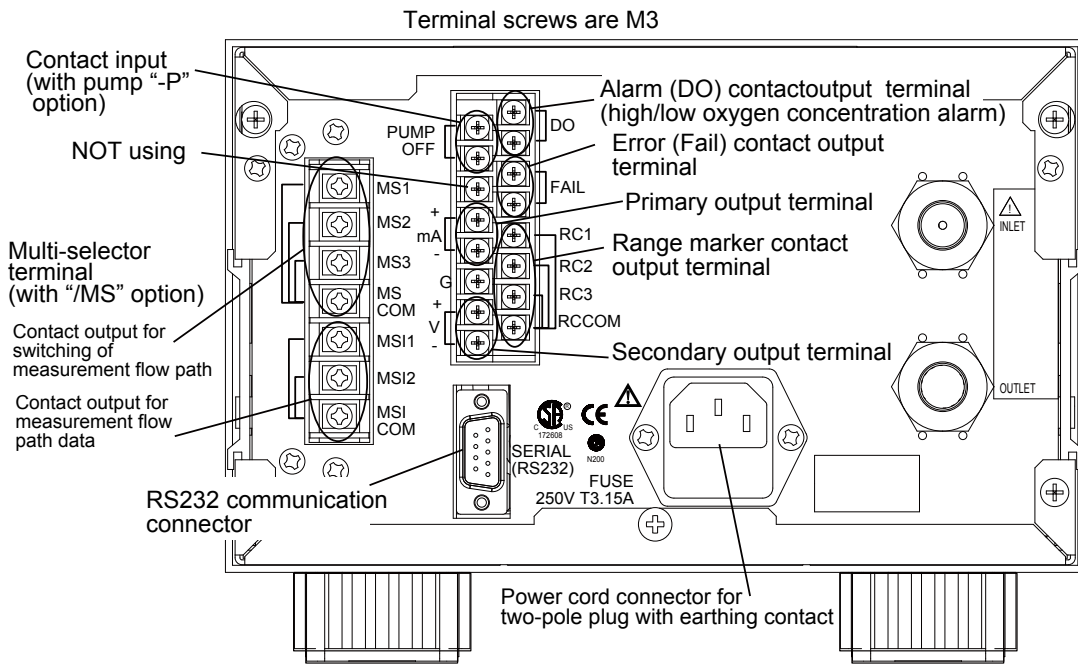

Figure 4.2 Piping for Sample Gas

4.2 Wirings

4.2.1 Power Supply Wiring

CAUTION

For the power supply, be sure to use the rated voltage shown on the rear panel. Connection to a power supply with a different voltage may cause damage to the OX400. Power cord connector with a protective ground pin is used for power supply wiring for the OX400. Be sure to securely insert the connector of supplied power supply cord to the OX400, and connect the plug to a 3P socket with a protective ground pin.

WARNING

Before connecting wires, be sure to remove the power plug from the socket and check that the power is turned off in order to prevent electric shock. Furthermore, after finishing the wiring, be sure to secure the special terminal cover with screws.

- Do not use the supplied power cord with another device.

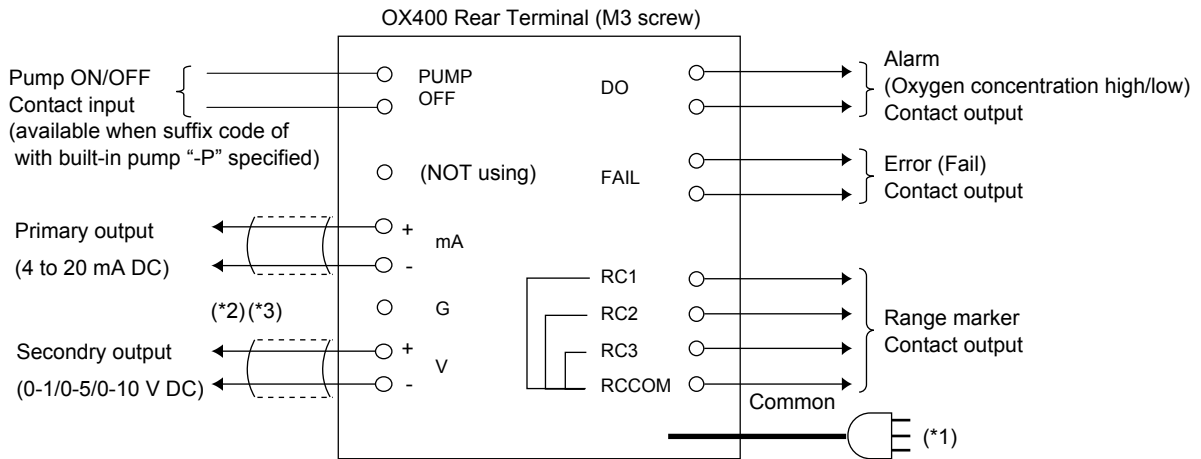

- *1: Use the earthing contact of power cord to ground to earth. Use the supplied power cord only.
- *2: Ground the measurement output signal line shield on the receiving side. The G-terminal is connected to a ground pin. Use this if the line shield cannot be grounded on the receiving side. Be very careful not to ground the line at two points.
- *3: The signal output and contact input cable must be no longer than 30 m for CE marking. RS232 cable must be no longer than 3 m.

The following terminals are added for the multi-selector "/MS" option. The customer needs to supply a switching device and carry out the necessary wiring.

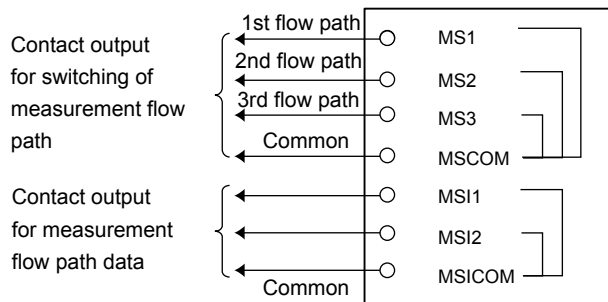

Figure 4.3 External Wiring Diagram

4.2.2 Signal Wiring

Table 4.1 shows the signal assignments of terminals on the rear panel. Perform wiring as necessary. It is recommended to use an insulation sleeve crimp terminal (for M3 screws) for cable termination.

Table 4.1 List of Input and Output Signals

Type of Signal	Terminal Marking	Description	Screw	Wiring Limit
Primary output terminal	mA + -	4-20 mA current output	M3	(*1)
Secondary output terminal	V + -	0-1, 0-5, 0-10 V DC voltage output	M3	(*1)
Range marker terminal	RC1, RC2, RC3, RCCOM	For auto range recognition	M3	
Contact input terminal	PUMP OFF	For pump remote ON/OFF	M3	(*1)
Error contact output terminal	FAIL	Output in the event of an error (ERR)	M3	
Alarm contact output terminal	DO	Output in the event of an oxygen concentration alarm (ALM7)	M3	
Contact output terminal for multi-selector	MS1, MS2, MS3, MSCOM MSI1, MSI2, MSICOM	For measurement flow path switching (1 to 3) For information on flow path under measurement	M3	

*1: The current or voltage signal output cable length must be no longer than 30 m for CE use.

(1) Primary output terminal

This is a terminal to output oxygen concentration at a 4-20 mA DC current. Use it at a load resistance of 550Ω or less. The wire shall be shielded, and the shield shall be connected to the ground on the receive side and open on the OX400 side.

(2) Secondary output terminal

This is a terminal to output oxygen concentration in terms of voltage. Specify in advance one of 0-1, 0-5, and 0-10 V DC. Use it at a load resistance of 10 kΩ or more. The wire shall be shielded, and the shield shall be connected to the ground on the receive side and open on the OX400 side.

(3) Range marker output

Range recognition information such as the auto range is expressed as a 3-bit code. This is a non-voltage contact output signal.

- "1" when lines between RC1, RC2, and RC3 terminals and RCCOM are closed, and "0" when open. Range recognition information is as shown in Table 4.2. The contact capacity is 2 A/30 VDC.

Table 4.2 Output Correspondence Table of Measurement Range and Marker

Measurement Range	RC3	RC2	RC1
0-10 ppm (Note)	0	0	1
0-100 ppm (Note)	0	1	0
0-1000 ppm (Note)	0	1	1
0-1% (Note)	1	0	0
0-10% (Note)	1	0	1
0-100%	1	1	0
(MANUAL fixed range)	1	1	1
(Partial range)	0	0	0

(Note) Range of auto range can be changed as follows.

0-20 ppm	0-30 ppm	0-90 ppm
0-200 ppm	0-300 ppm	0-900 ppm
0-2000 ppm	0-3000 ppm	0-9000 ppm
0-2%	0-3%	0-9%
0-20%	0-30%	0-90%

(4) Contact input terminal

This is a terminal to remotely turn on and off the internal pump using an external contact. This is enabled only when the pump switch on the front panel of the OX400 is ON. The pump is OFF when the contact is closed, and ON when the contact is open.

Nothing happens if the OX400 is not equipped with a pump.

(5) Error contact output terminal

If an error (ERRx) occurs, the contact closes.

(6) Alarm contact output terminal

If an oxygen concentration high/low limit alarm (ALM7) occurs, the contact closes.

(7) Contact output terminal for flow path switching by multi-selector (option)

This terminal is added only when the option "/MS" is specified.

- Output terminal for measurement path flow switching: This is a contact output to switch valves for sampling flow paths by panel operation of the OX400. You can select and turn on one of the three flow paths. "1" when lines between MS1, MS2, MS3 terminals and MSCOM are closed, and "0" when open. For details, see Section 6.5.

Table 4.3 Measurement Flow Path Switching Output by Multi-selector

	MS1-MSCOM	MS2-MSCOM	MS3-MSCOM
MS OFF	0	0	0
MS1 ON (Select flow path 1)	1	0	0
MS2 ON (Select flow path 2)	0	1	0
MS3 ON (Select flow path 3)	0	0	1

- Output of information on flow path under measurement by multi-selector: Answer-back output of the flow path that is being measured. "1" when lines between terminals MSI1/MSI2 and MSICOM are closed, and "0" when open.

Table 4.4 Output of Information on Flow Path under Measurement by Multi-selector

	MSI1-MSICOM	MSI2-MSICOM
MS OFF	0	0
MS1 (Flow path 1 under measurement)	1	0
MS2 (Flow path 2 under measurement)	0	1
MS3 (Flow path 3 under measurement)	1	1

CAUTION

Be careful because the contact output is open when the power of the OX400 is OFF.

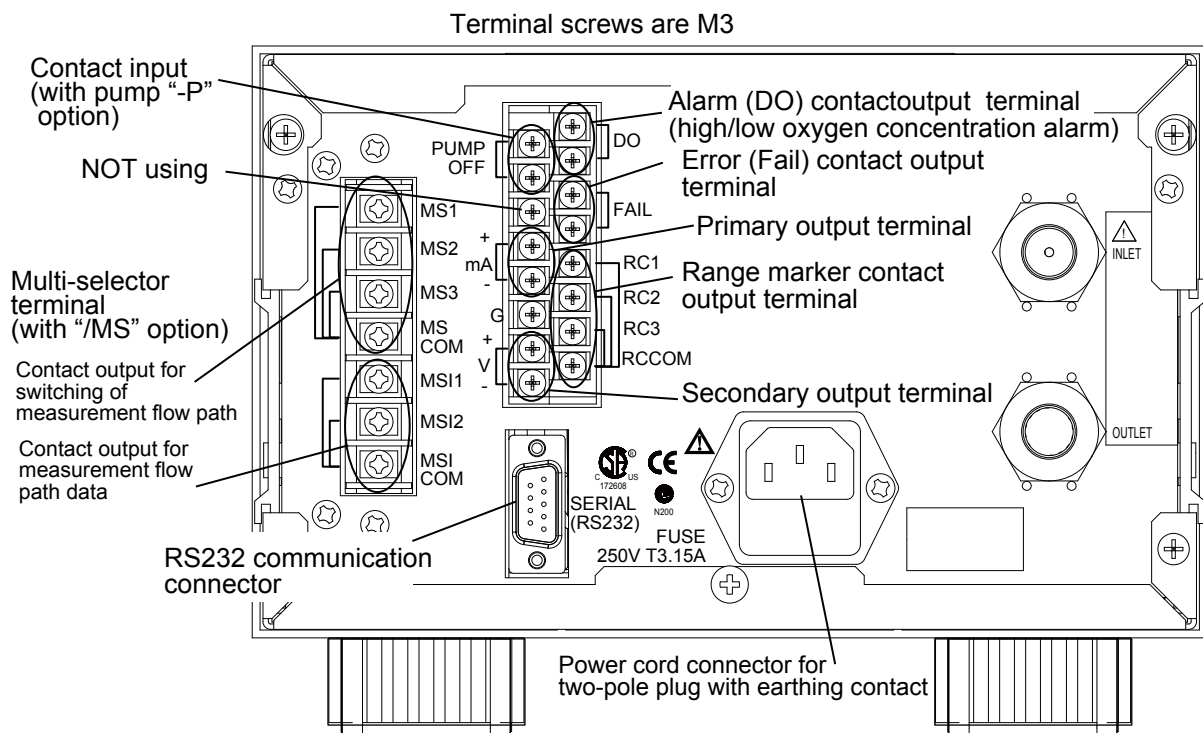

Figure 4.4 Wiring Terminals

4.2.3 Communication

A D-sub 9-pin connector for RS232 communication is located on the rear panel of the OX400. RS232 connection cable length must be no longer than 3 m for CE marking.

5. Names and Functions

5.1 Front Panel



Figure 5.1 Description of Front Panel

① Main Display

The main display digitally displays the oxygen concentration and set value in four digits with a decimal point. The display flashes at one-second intervals while waiting for key input.

② Oxygen Concentration Unit LED

The unit of displayed oxygen concentration is displayed by LED. The LED is not on when a non-oxygen concentration value is displayed. The unit you selected flashes until you confirm it.

③ MODE LED

The LED turns on when you push the MODE switch to enable the maintenance mode. The LED is off in the measurement mode.

④ ERR/ALM LED

The event of an error causes the LED to turn on. The event of an alarm causes the LED to flash. If an error and alarm occur at the same time, the error is given priority and the LED turns on. The LED is off during normal operation.

⑤ Sub-Display

The sub-display displays the description of the currently displayed item or menu item in four digits with a decimal point. If an error or alarm occurs, the error or alarm code corresponding to the content is displayed. "HEAT" is displayed during the warm-up period.

⑥ Flowmeter

The flowmeter uses a floater to indicate the flow rate of gas flowing into the sensor. Always set the value to 200 ±25 mL/min (a floater should be between upper and lower bar of the 200 mL/min bar on flowmeter).

⑦ MODE Key

Hold down the key for 2 seconds to switch from the measurement mode to the maintenance mode (or from the maintenance mode to the measurement mode).

⑧ Arrow Keys

[◀], [▶]: Press the keys to move through the digits of the number to be set. [▲], [▼]: Press the keys to scroll through the numbers or items to be set.

⑨ SETTING/ENTER Key

Press the key to confirm the item or number to be set. Press [ENT] to display the operation description.

⑩ Gas Flow Rate Adjustment Knob

Use the knob to adjust the gas flow rate of gas flowing into the sensor.

⑪ PUMP Switch

Turn the switch on to use the built-in pump. This switch is effective only when the POWER switch is on.

⑫ POWER Switch

This is the power switch of the OX400.

The LED display employs a 7-segment alphanumeric display. Figure 5.2 shows the display characters and alphanumeric characters in the display.

Alphanumerics	LED Display	Alphanumerics	LED Display	Alphanumerics	LED Display
A	A	N	n	0	0
B	b	O	o	1	1
C	C	P	P	2	2
D	d	Q	q	3	3
E	E	R	r	4	4
F	F	S	S	5	5
G	G	T	t	6	6
H	H	U	U	7	7
I	I	V	V	8	8
J	J	W	W	9	9
K	K	X			
L	L	Y	Y		
M	M	Z	Z		

Figure 5.2 LED Display and Alphanumeric Characters

5.2 Rear Panel

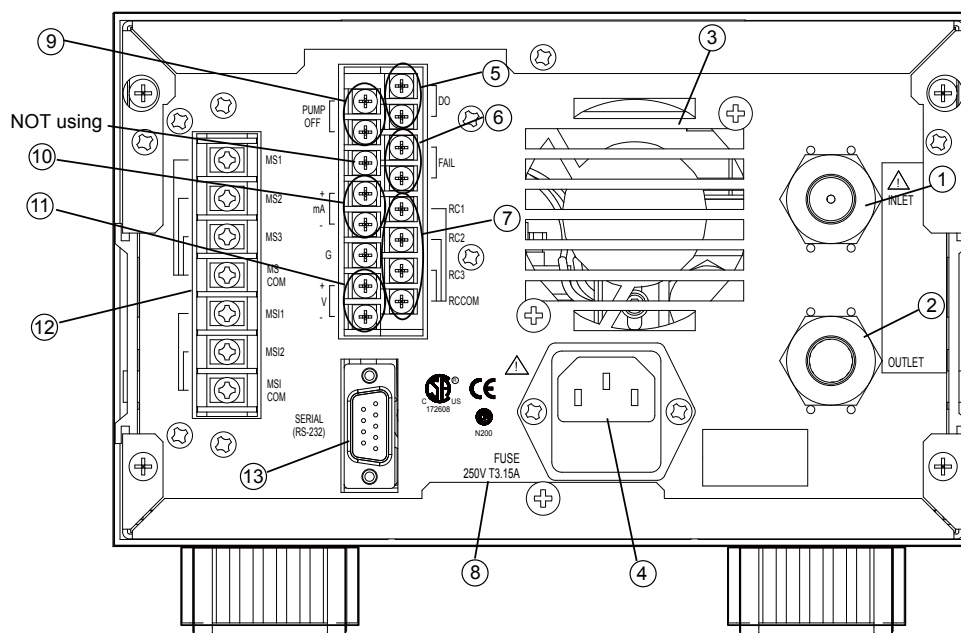

Figure 5.3 Description of Rear Panel

- ① Gas Inlet
This is an inlet for introducing sample gas. The connector is Rc1/4 or 1/4NPT.
- ② Gas Outlet
This is an outlet for discharging sample gas. The connector is Rc1/4 or 1/4NPT.
- ③ Fan
This is a cooling fan inside the OX400. Make sure the outlet of the fan is not blocked
- ④ Power Plug
This is a 3P power plug with a ground terminal. A fuse is included. Use the supplied power cord. Do not use the power cord with another device.
- ⑤ Contact Output Terminal (DO Output)
The event of a high or low oxygen concentration alarm “ALM7” causes output at the terminal. It does not work without a concentration alarm.
- ⑥ Contact Output Terminal (FAIL)
This is a contact output terminal for errors. The event of an error causes output.
- ⑦ Contact Output Terminal for Range Output
In the auto range, the current range is output at the contact output terminal
- ⑧ Fuse Rating Display
The rating of the power fuse is displayed.
- ⑨ Contact Input Terminal
This contact input terminal is used to turn on and off the suction pump from the outside.
- ⑩ External Output Terminal (Primary Output)
Measured values are output at 4-20 mA DC in the set measurement range.

⑪ External Output Terminal (Secondary Output)

Measured values are output at the set voltage (0-1, 0-5, and 0-10 V DC)

⑫ Multi-Selector Contact Output Terminal

This is the contact output to switch measurement flow path. Furthermore, measurement flow path data is output at this contact output terminal.

⑬ RS232 Connector

A D-sub 9-pin connector is connected to this connector when using serial communication.

6. Operation and Parameters

The OX400 has two modes, “**Measurement Mode**” and “**Maintenance Mode**.” Oxygen concentration is displayed in the measurement mode. The setting of operation parameters and calibration operation are performed in the maintenance mode. Furthermore, the MODE LED on the front panel is on in the maintenance mode. To enter the maintenance mode, or to return to the measurement mode from the maintenance mode, hold down the [MODE] key for two seconds. The parameters shown in Figure 6.1 are available in the maintenance mode. Parameters can be displayed by scrolling with the [▼], [▲] keys.

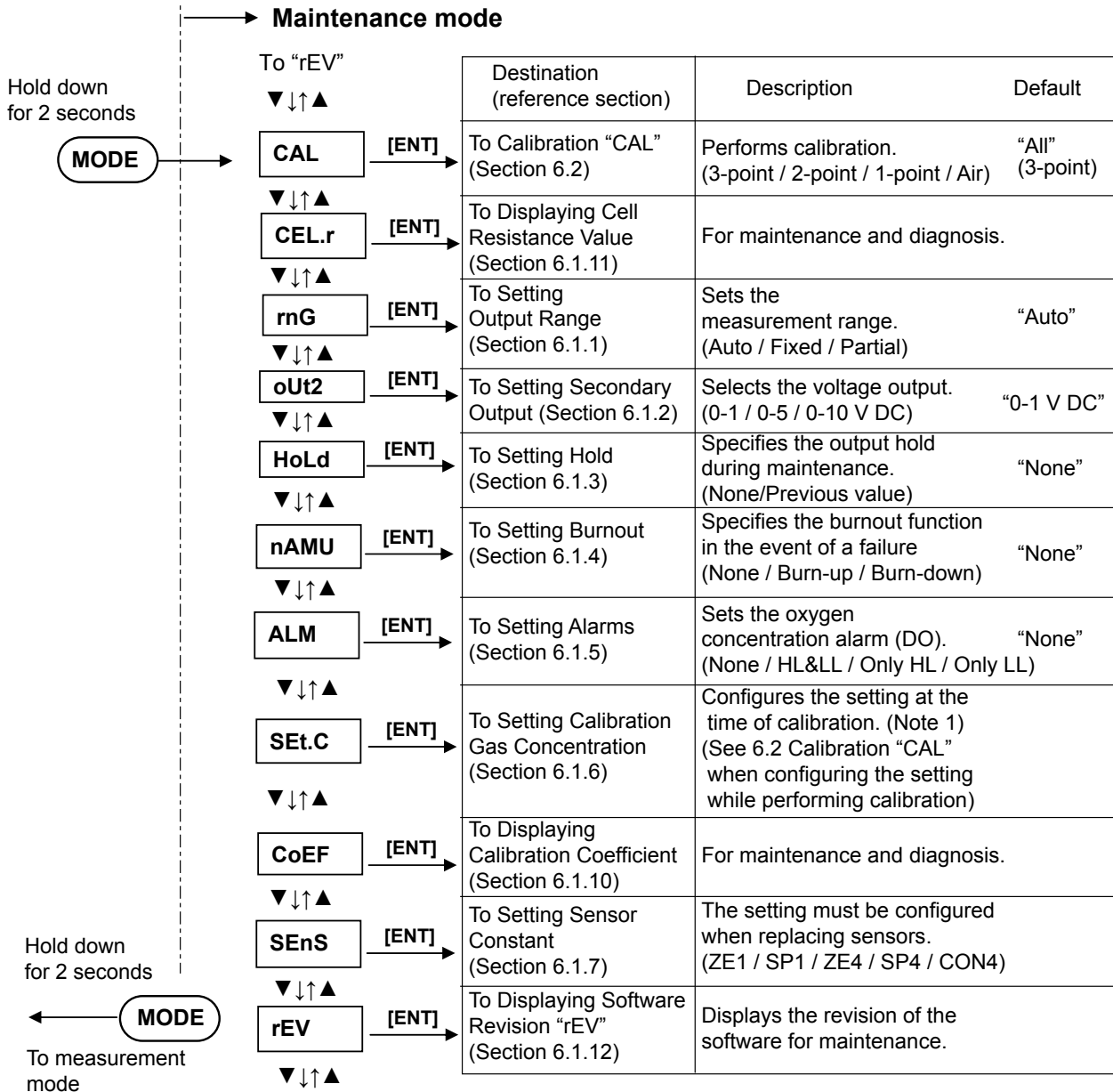

Note 1: When “Air” is selected in Calibration “Cal,” the “SEt.C” menu is not displayed.

Note 2: Some settings are omitted in the above flow chart.

For setting output smoothing function of “SMoo” menu, see Section 6.1.8.

When switching of measurement flow path using the Multi-selector, set the measurement flow path (1 to 3) in “MLS.” For the operation of the “MLS” menu, see Section 6.1.9.

Figure 6.1 List of Parameters in Maintenance Mode

6.1 Startup and Settings

Turning on the Power

Turn on the POWER switch on the front panel. After all displays turn on, the warm-up screen “HEAT” appears, and the OX400 automatically enters the warm-up mode.

The remaining warm-up time is displayed and counted down from 20, and when the warm-up time ends, the measurement screen appears automatically. The warm-up time is about 20 minutes.

The mA output is 4 mA during the warm-up time, and the voltage output is 0 V. Furthermore, it is recommended to check and set the parameters during the warm-up time.

The following shows the operating procedure.

1. Set the parameters required for operation (in the maintenance mode).
2. Check and adjust the sample gas flow rate (200 ±25 mL/min, a floater should be between upper and lower bar of the 200 mL/min bar on flowmeter)
3. Check the measured values (in the measurement mode), and perform calibration, if necessary (in the maintenance mode).

6.1.1 Setting Output Range “rnG”

Operation: Hold down the [MODE] key for 2 seconds, select “rnG” with the [▲], [▼] keys, and press the [ENT] key.

Roughly three types of measurement range are available, “Auto Range,” “MANUAL Range,” and “Partial Range.”

(1) Auto Range “AUto” (auto range)

With respect to this range, the range is switched automatically depending on the oxygen concentration value. Enter range code “1” (default) if the full scale is always 10×10^n , as in the case of 0 to 10 ppm, 0 to 100 ppm, 0 to 1000 ppm, 0 to 10%, 0 to 100%. Furthermore, enter range code (□) “2” to “9”, as in the case of 0 to □0 ppm, 0 to □00 ppm, 0 to □000 ppm, 0 to □0%. For example, enter range code “2” if 20×10^n applies, as in the case of 0 to 20 ppm, 0 to 200 ppm, 0 to 2000 ppm, 0 to 2%, 0 to 20%.

(2) MANUAL Range “MAn” (fixed range)

This range is a fixed range. Select one from the following six ranges: 0 to 10 ppm, 0 to 100 ppm, 0 to 1000 ppm, 0 to 1%, 0 to 10%, and 0 to 100%. The range is always the same and is independent from the oxygen concentration.

(3) Partial Range “FrEE”–“Fr.HI” –“Fr.Lo” (free range)

With respect to this range, any range can be set and fixed. However, the smallest span of the range must be more than 20%FS of the above MANUAL range.

Examples: 2 to 4 ppm if the MANUAL range is 0 to 10 ppm
 60 to 80 ppm if the MANUAL range is 0 to 100 ppm

NOTE: Flashing italic characters such as “*1.000*” used in the subsequent operation flow charts mean waiting for key input. Furthermore, the larger box means the main display (large digital display) on the front panel and the smaller box means the sub-display (small digital display).

Operation in the maintenance mode

Press the **MODE** key to return to the previous operation.

Hold down the **MODE** key for 2 seconds to return to the measurement mode.

You may need to enter a numerical value, decimal point, and unit during the operation.

The following operation flow charts may omit this operation. For details of the numerical value, decimal point, and unit operation, see Section 6.6.

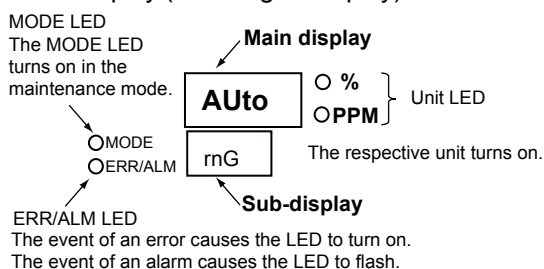

6.1.2 Setting Secondary Output “oUt2”

Operation: Hold down the [MODE] key for 2 seconds, select “oUt2” with the [▲], [▼] keys, and press the [ENT] key.

With respect to the secondary output, select one of the three types of voltage output: 0-1 V is “1,” 0-5 V is “5,” and 0-10 V DC is “10.” Figure 6.3 shows an example of setting 0-1 V DC “1.”

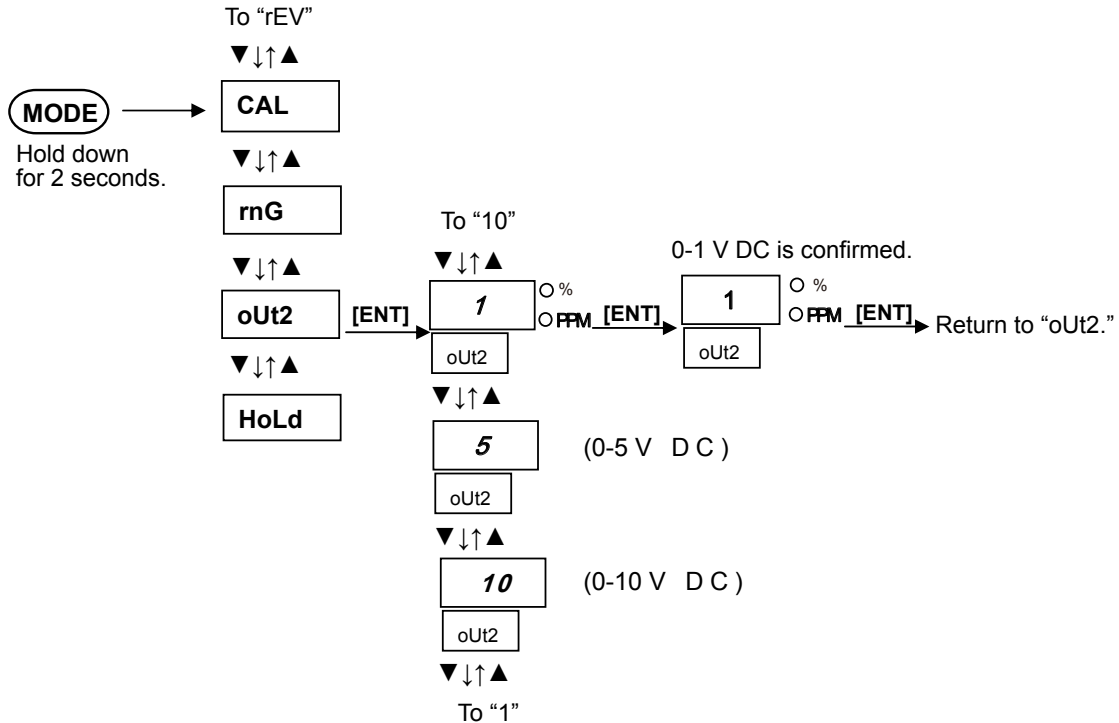

Figure 6.3 Setting Secondary Output “oUt2”

6.1.3 Setting HOLD Function “HoLd”

Operation: Press the [MODE] key for 2 seconds, select HoLd with the [▲], [▼] keys, and press the [ENT] key.

Set the output state in the maintenance mode. Select either “non” or “PrEV.” The former option means no hold, and the latter means hold the previous value. The following is an example of no hold.

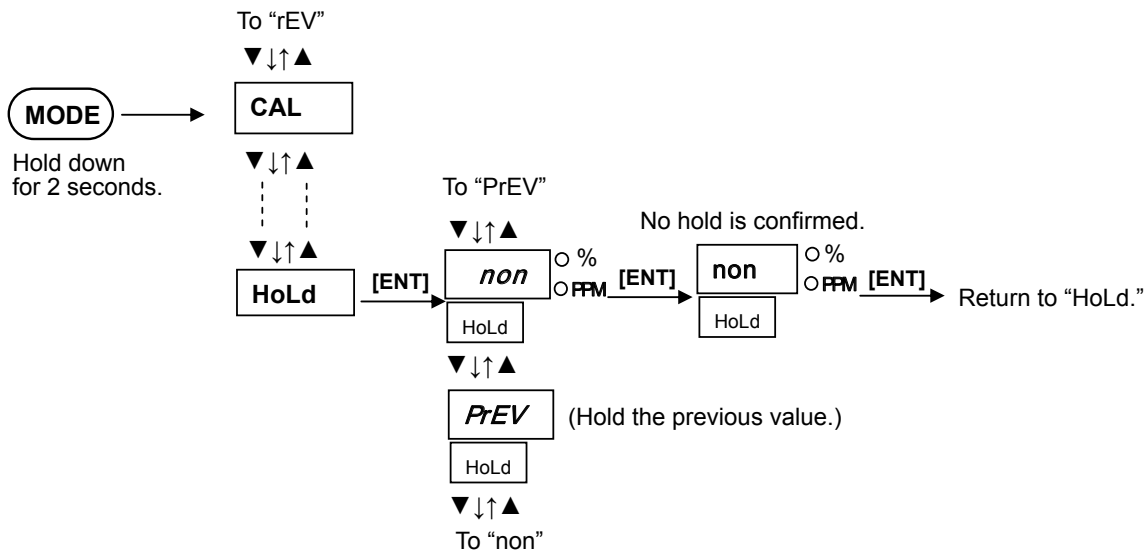

Figure 6.4 Setting HOLD “HoLd”

6.1.4 Setting Burnout Function “nAMU”

Operation: Hold down the [MODE] key for 2 seconds, select “nAMU” with the [▲], [▼] keys, and press the [ENT] key.

Set the burnout function for the primary current output of 4-20 mA DC (compliant with NAMUR). Select one of the options: No burnout function is “non,” burn-up is “Er.HI,” and burn-down is “Er.Lo.”

Figure 6.5 shows an example of setting burn-up.

NOTE: Burnout is a function compliant with NAMUR that allows increasing/decreasing the current output to the high/low limits in the event of a failure. Burn-up allows increasing the output to the high limit of 21.0 mA and burn-down allows decreasing the output to the low limit of 3.6 mA. The burnout function works in the event of an error (when the FAIL contact output closes).

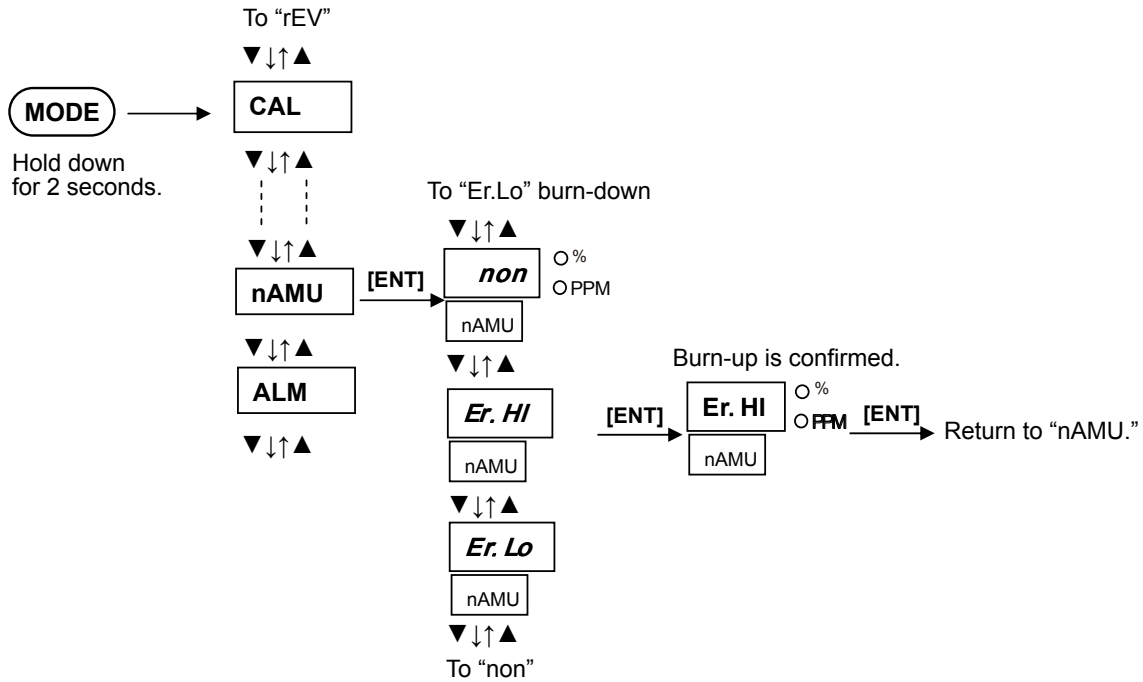

Figure 6.5 Setting Burnout “nAMU”

6.1.5 Setting Alarms (Oxygen Concentration High/Low Alarms) “ALM”

Operation: Hold down the [MODE] key for 2 seconds, select “ALM” with the [▲], [▼] keys, and press the [ENT] key.

High and low limit alarms can be set to the measured oxygen concentration values. With respect to the alarm setting, the following four options are available: No alarm “oFF,” high/low limits “ALL,” high limit alarm “AL.HI,” and low limit alarm “AL.Lo.” If the high and low limit values are reversed or the set value is larger than 100%, an input error occurs and the setting is not accepted. Furthermore, the DO contact output closes in the event of an oxygen concentration alarm (ALM7). In other words, an alarm contact is activated.

Figure 6.6 shows a setting example. With respect to the input method of a numerical value, decimal point, and unit, see Section 6.6.

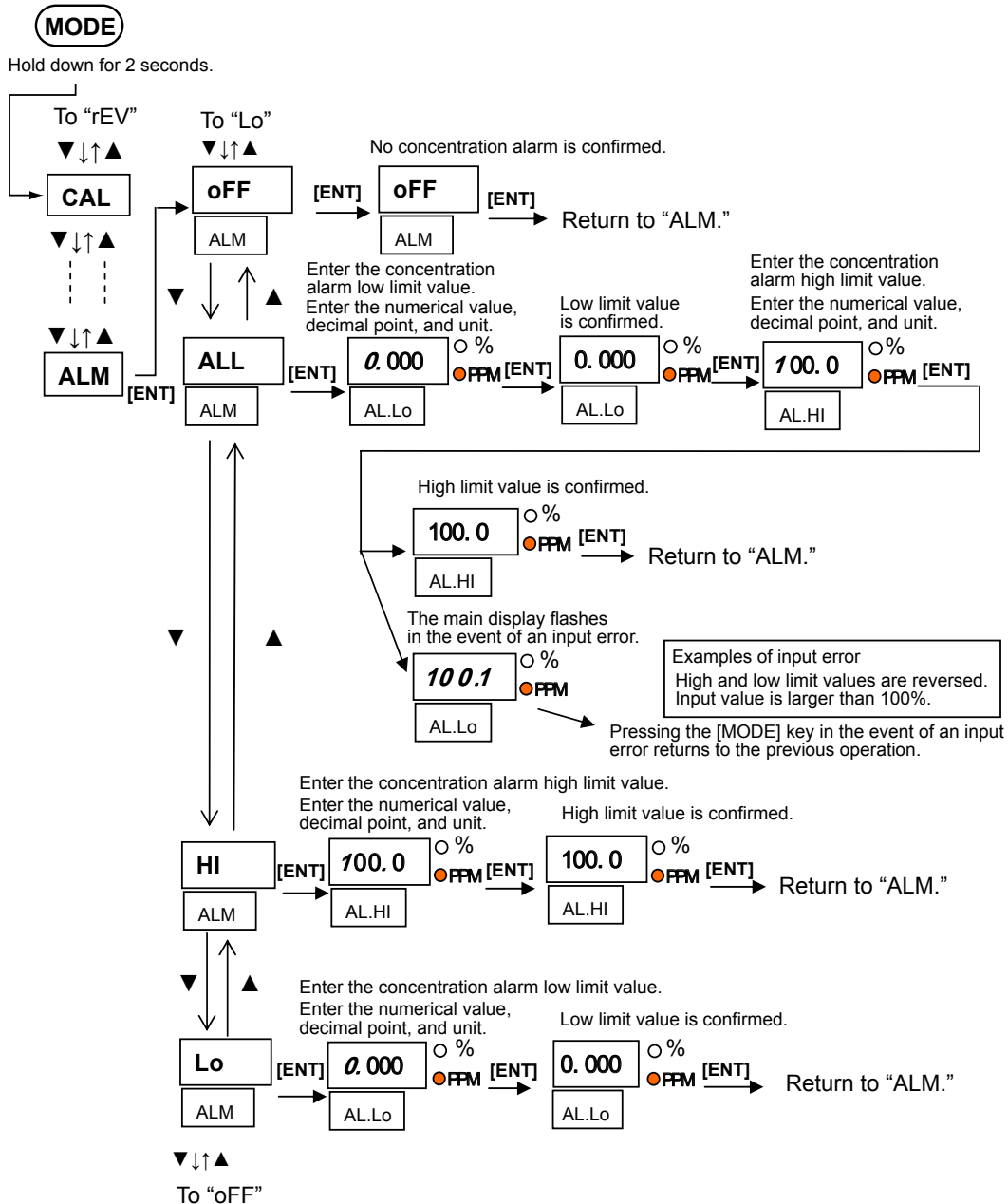

Figure 6.6 Setting Alarm (Oxygen Concentration Alarm) “ALM”

6.1.6 Setting Calibration Gas Concentration “SEt.C”

Operation: Hold down the [MODE] key for 2 seconds, select “SEt.C” with the [▲], [▼] keys, and press the [ENT] key.

Set the O₂ concentration of gas used for calibration. Alternatively, this setting can be performed while performing calibration “CAL.” The gas concentration that can be set is restricted depending on which calibration is performed (which depends on the specification in calibration “CAL”). The oxygen concentration of air is fixed to 20.6% O₂, so it cannot be set. Figure 6.7 shows a setting example in 3-point calibration “ALL.” With respect to the input method of a numerical value, decimal point, and unit, see Section 6.6.

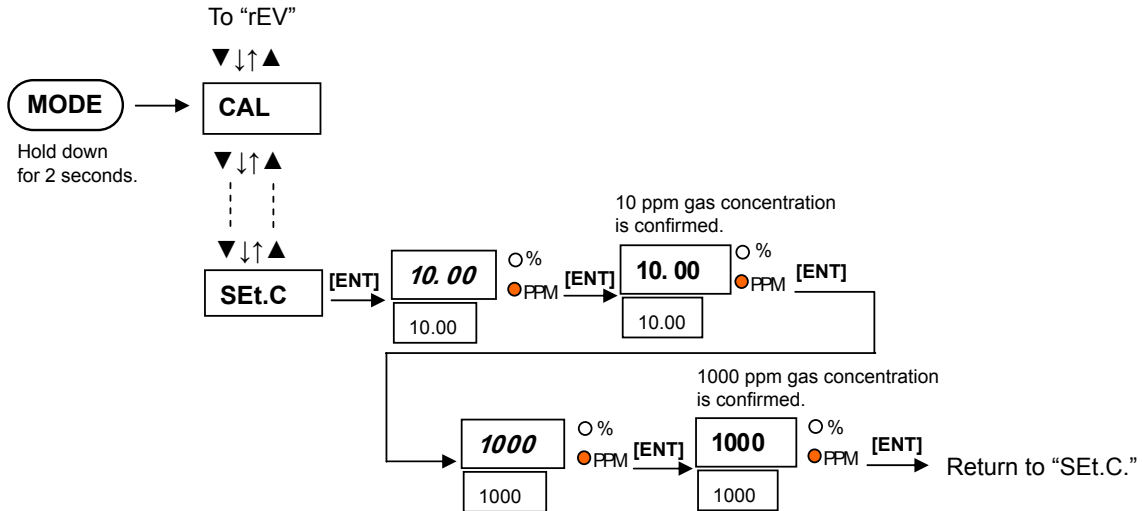
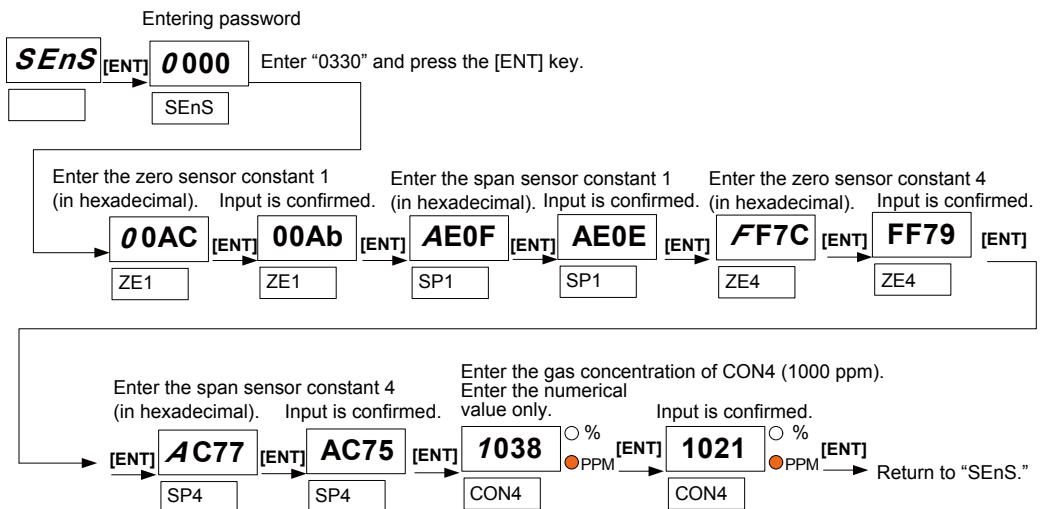

Figure 6.7 Setting Calibration Gas Concentration “SEt.C”

6.1.7 Setting Sensor Constant “SEnS”

Operation: Hold down the [MODE] key for 2 seconds, select “SEnS” with the [▲], [▼] keys, and press the [ENT] key.

Be sure to enter the sensor constant when replacing sensors. With respect to the sensor constant, the following five parameters are available: ZE1, SP1, ZE4, SP4, and CON4, which are on the constant tag of the sensor. Be sure to enter the right parameter. Figure 6.8 shows a setting example. These constants are specific to the sensor and remain the same for all operations. With respect to the input method of a numerical value, decimal point, and unit, see Section 6.6.



*The entered sensor constants are updated altogether when the input of CON4 is confirmed. If the input is interrupted halfway, it returns to the sensor constant before the input.

Figure 6.8 Setting Sensor Constants “SEnS”

6.1.8 Setting Output Smoothing “SMoo”

If the oxygen concentration of sample gas rapidly changes, and the measured value is used for control, harmful results may occur such as frequent on and off switching.

In such a case, signal changes can be smoothed by giving an appropriate time constant and performing calculation. Smoothing factor from 0 to 60 seconds can be set. When the output smoothing is set, the smoothed value is an instantaneous value, which is displayed and output in analog form. The smoothed value is also used as the instantaneous value for checking the concentration alarm and for RS232 communication. The output smoothing is “non” 0 second by default.

Operation: Hold down the [MODE] key for 2 seconds, select “SMoo” with the [▲], [▼] keys, and press the [ENT] key.

Figure 6.9 shows an example of setting the smoothing factor to 30 seconds.

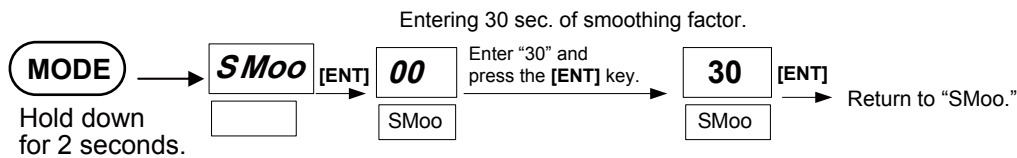

Figure 6.9 Setting Smoothing Factor “SMoo”

6.1.9 Setting Multi-Selector “MLS”

This item is an option, so you do not need to set it unless you specified the option code “/MS.”

Operation: Hold down the [MODE] key for 2 seconds, select “MLS” with the [▲], [▼] keys, and press the [ENT] key.

Set the relay contact to switch measurement flow for path. Up to three sampling flows can be selected. Even though this setting is performed for an OX400 for which the option code “/MS” was not specified, nothing will happen. Figure 6.10 shows a setting example (set measurement flow path 1 to 3). With respect to the usage example, see Section 6.5.

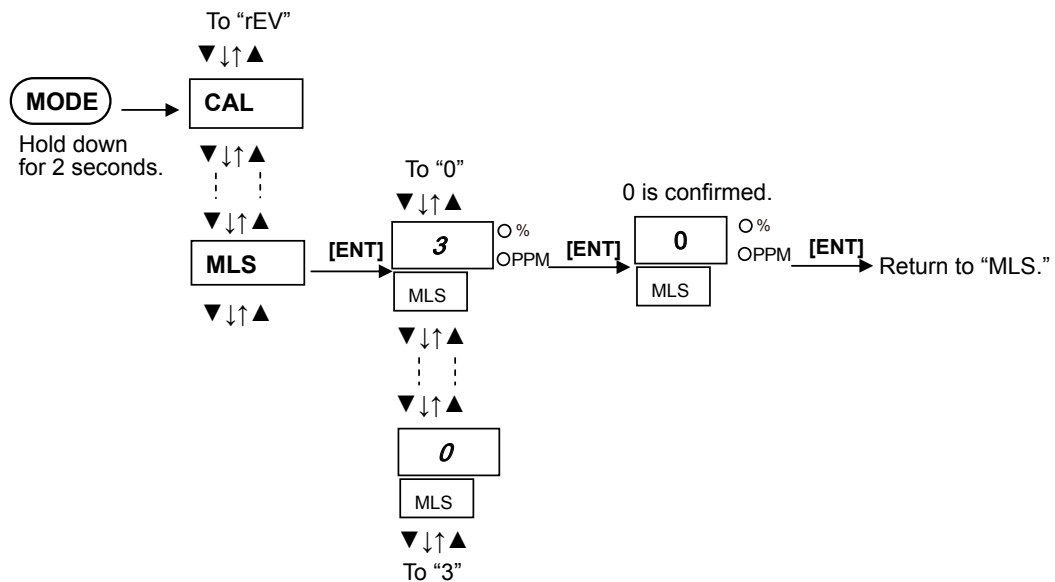

Figure 6.10 Setting Multi-Selector “MLS”

6.1.10 Checking Calibration Coefficient “CoEF”

This item is for checking the sensor state and is not a setting.

Operation: Hold down the [MODE] key for 2 seconds, select “CoEF” with the [▲], [▼] keys, and press the [ENT] key.

Check the current calibration coefficient. These coefficients are updated for each calibration. Figure 6.11 shows an example of checking the coefficient.

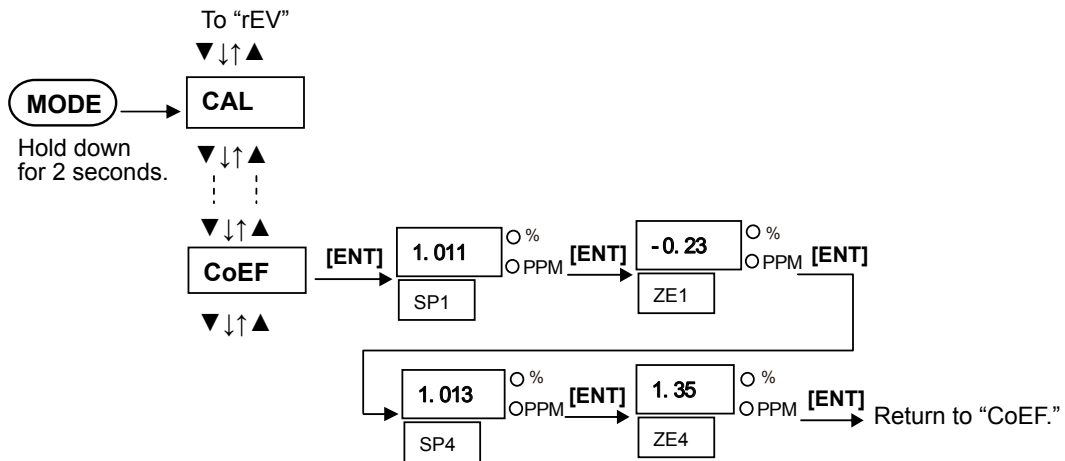

Figure 6.11 Checking Calibration Coefficient “CoEF”

6.1.11 Displaying Cell Resistance Value “CEL.r”

This item is for checking the sensor state and is not a setting.

Operation: Hold down the [MODE] key for 2 seconds, select “CEL.r” with the [▲], [▼] keys, and press the [ENT] key. The sensor cell resistance value is displayed. The unit is Ω. If the value becomes larger than 1050 Ω, “oVER” appears.



NOTE

When the sensor is replaced, the cell resistance value is not displayed. It is displayed when calibration of something other than air is performed.

Figure 6.12 shows an example of displaying the cell resistance value.

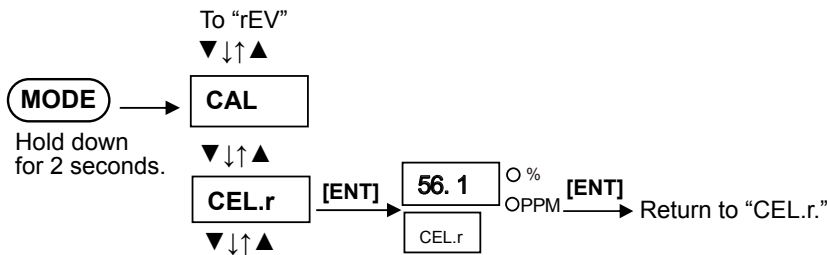

Figure 6.12 Displaying Cell Resistance Value “CEL.r”

6.1.12 Displaying Software Revision “rEV”

This item is for checking the software revision of the OX400 and is not a setting.

Operation: Hold down the [MODE] key for 2 seconds, select “rEV” with the [▲], [▼] keys, and press the [ENT] key.

The current software revision is displayed. Figure 6.13 shows a display example.

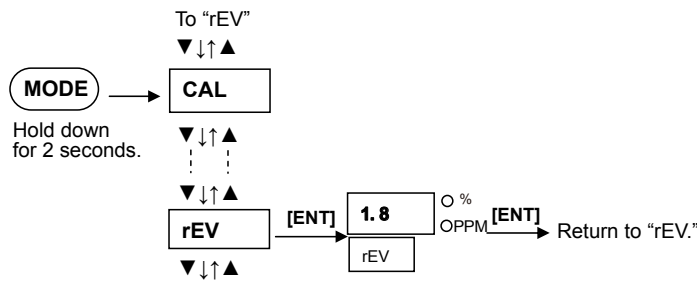

Figure 6.13 Display Software Revision “rEV”

6.2 Calibration “CAL”

Be sure to perform calibration in the measurement mode after the warm-up operation ends. Calibration cannot be performed during the warm-up operation. If an error occurs during calibration, that calibration will be invalid, and keys other than the [MODE] key become invalid. Hold down the [MODE] key for 2 seconds to return to the beginning of the calibration “CAL” and press the [MODE] key again to return to the measurement state.

With respect to the calibration methods of the OX400, there are four types of method.

(1) 3-point (All) calibration “ALL”

By performing calibration at the three points of 10 ppm, 1000 ppm, and Air, the linearity for the entire zone between 0-10 ppm and 100% O₂ is guaranteed. Gas used for calibration is restricted to the ranges of O₂ concentration as follows.

- (1) 8 ppm ≤ 10 ppm gas ≤ 20 ppm
- (2) 800 ppm ≤ 1000 ppm gas ≤ 2000 ppm
- (3) O₂ concentration in Air: 20.6% (Normal air is within this range)

Note: Be sure to use gas that meets conditions (1), (2), and (3) for calibration.

(2) 2-point calibration “2Pnt”

Select zero and span calibration points in the measurement range you will use to perform calibration. However, gas used for calibration is restricted to the ranges of O₂ concentration as follows.

<When the range is 1000 ppm or less.>

- (1) Zero gas is 8%FS or more.
- (2) Span gas is less than 120%FS.
- (3) Between zero and span of the smallest range must be more than 20%FS of the MANUAL range.

Example 1: Two points of 1 ppm and 3 ppm in the 10 ppm range

Example 2: Two points of 20 ppm and 40 ppm in the 100 ppm range

< When the range is more than 1000 ppm.>

- (1) Zero gas is 800 ppm or more.
- (2) Span gas is 100%FS or less.
- (3) Between zero and span of the smallest range must be more than 2000 ppm.

Example 3: Two points of 0.6% and 0.8% in the 1% range

Example 4: Two points of 20.6% and 90% in the 100% range

(3) 1-point calibration “1Pnt”

Principally, 1-point calibration allows obtaining an accurate concentration in an area near the calibration point, but the error may become greater as the distance from the calibration point increases. This is a useful calibration method when it is used in some limited areas. Select one point in an area as close to the concentration you want to measure as possible to perform

calibration. However, there are the following limits to the O₂ concentration. Be sure to perform calibration in that range of the O₂ concentration.

O₂ concentration limits: 0.9 ppm or more and 12% or less, or between 35% and 100%.

(4) Air calibration “AIR”

This is air-only calibration. Uses the cleanest air possible to perform calibration.

Note: If you press the [MODE] key during calibration to exit the calibration mode, that calibration becomes invalid.

If an error occurs during calibration, the ERR/ALM lamp turns on, and an error/alarm code is displayed on the sub-display. That calibration may become invalid depending on the error factor.

Figure 6.14 shows the calibration method (including the calibration gas concentration setting). With respect to the input method of a numerical value, decimal point, and unit, see Section 6.6.

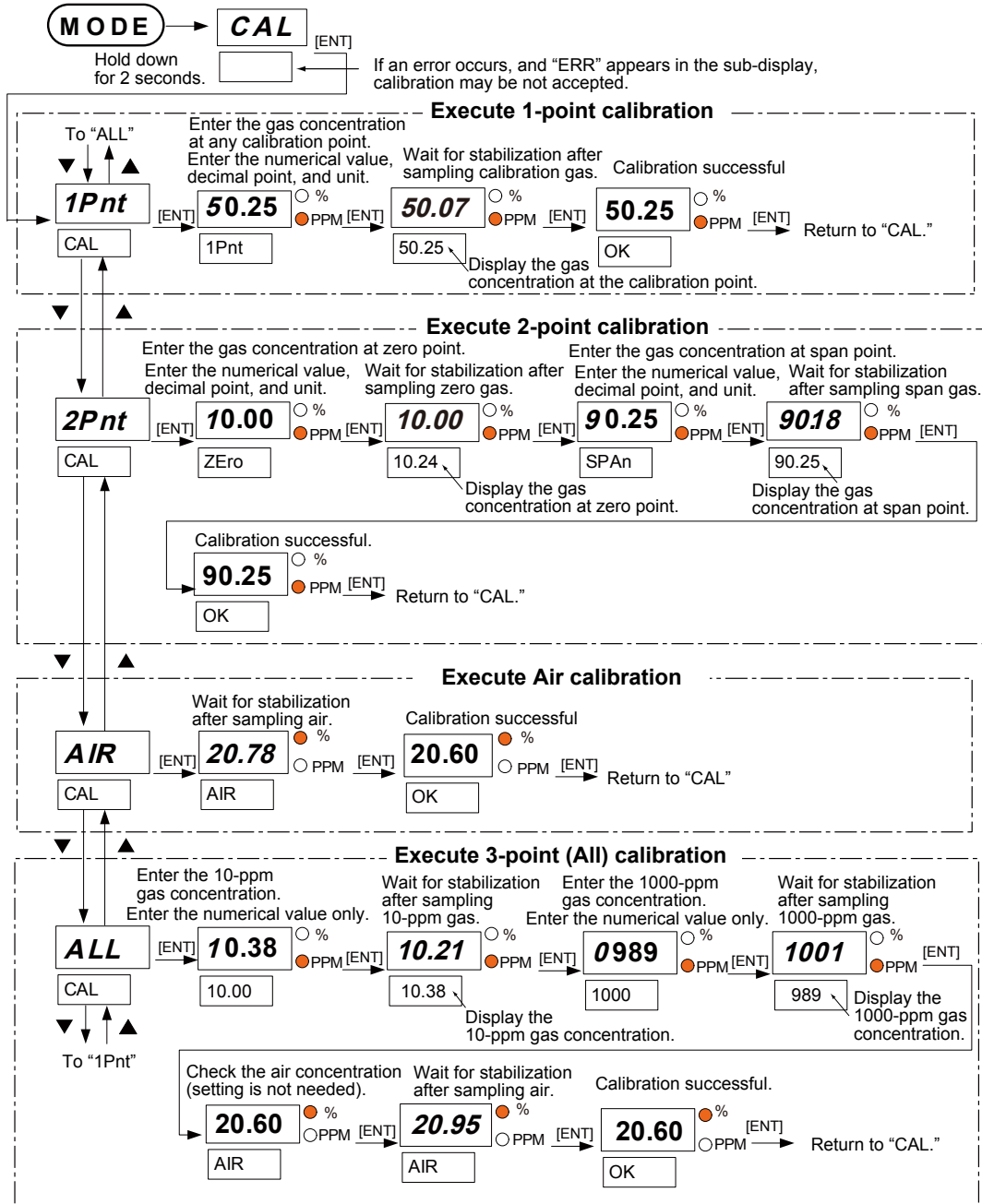

(Note) If an error occurs during calibration, that calibration may become invalid. With respect to the action in the event of an error, see Section 7.2.

Figure 6.14 Calibration “CAL”

6.3 Communication

The OX400 has RS232 serial communication as standard. Oxygen concentration, alarm, and error information are transmitted via this communication. The following shows the communication specifications.

- **Communication Specifications**

Table 6.1 Communication Specifications

Item	Description
Communication method	One-way (transmission only), asynchronous
Data format	ASCII
Baud rate	38400 bps
Data length	8-bit
Parity	None
Stop bit	1-bit
Flow control	None

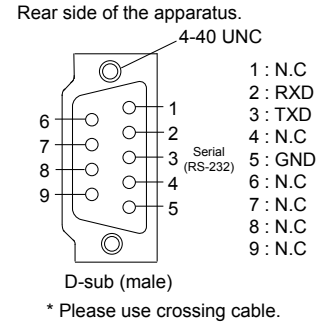

- **Data Logging Packet**

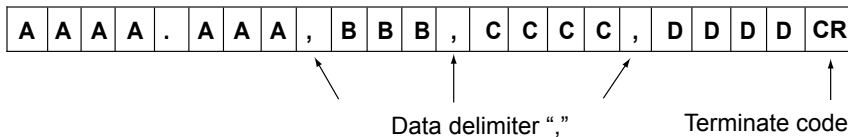

Figure 6.15 Configuration of Data Logging Packet

When communication terminal sends “TS” command to the OX400, OX400 will feed back data logging packet periodically (approx. 200 ms.) When you want to stop comm, send the stop command “CR”. The content of the data logging packet has the following meanings.

Table 6.2 Content of Data

Data	Content
AAAA.AAA	Oxygen concentration value
BBB	Unit
CCCC	Error (hexadecimal display)
DDDD	Alarm (hexadecimal display)

(1) Oxygen concentration value

The oxygen concentration value is displayed in the AAAA.AAA format and up to the three decimal places are output.

Note: When the output smoothing is set, the smoothed value becomes an oxygen concentration value.

(2) Unit

The unit is displayed in the BBB format. The output character is “%” or “ppm.”

(3) Error

The error is displayed in the CCCC format. The output characters are displayed in hexadecimal format, and Table 6.3 shows the error factors and output characters.

Table 6.3 Error Factor and Output Character List

Output characters	Error factor
0001	Err1: Sensor error
0002	Err2: Heater temperature error
0004	Err3: Temperature sensor burnout
0008	Err4: Device temperature error
0010	Err5: CPU error
0020	Err6: FAN stop

If multiple errors occur, the logical sum of output characters is output.

Example 1 : 0003; Err1 and Err2 are occurring

Example 2 : 0017; The four errors Err1, Err2, Err3, and Err5 are occurring.

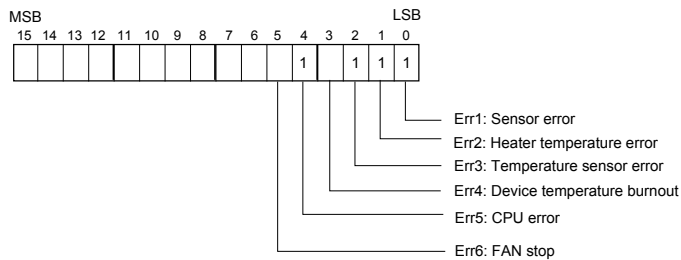

Figure 6.16 Configuration of Error Data (0017)

(4) Alarm

The alarm is displayed in the DDDD format. The output characters are displayed in hexadecimal format, and Table 6.4 shows the error factors and output characters.

Table 6.4 Alarm Factor and Output Character List

Output Characters	Alarm Factors
0001	ALM1: Heater unstable (temperature unstable)
0002	ALM2: Sensor failure
0004	ALM3: Electromotive force (EMF) error
0008	ALM4: Asymmetrical voltage error
0010	ALM5: Calibration error
0020	ALM6: Sensor resistance value error
0040	ALM7: Oxygen concentration Hi/Low limit error
0080	ALM8: Over range error

If multiple alarms occur, the logical sum of output characters is output.

Example 1: 00C0: ALM7 and ALM8 are occurring.

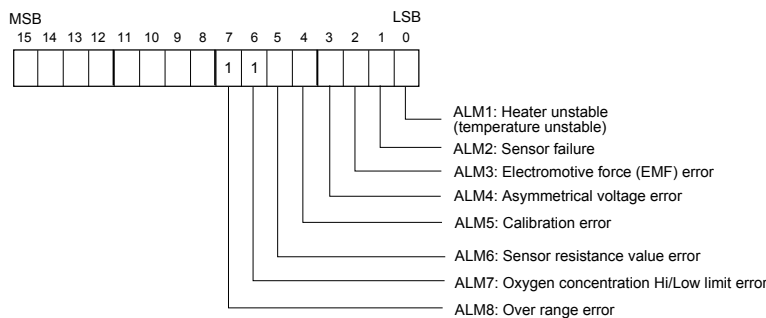

Figure 6.17 Configuration of Alarm Data (00C0)

6.4 Measurement Gas Sampling Using Aspirator

If you selected “-A”: with an aspirator as the sampling method, an aspirator is included in the OX400 package. Connect the aspirator to the sample gas outlet on the rear panel of the OX400.

If you selected “T”: 1/4NPT as the piping connector, connect an adapter between the sample gas outlet and the aspirator.

Supply clean air or N₂ gas to the aspirator. The external diameter of the gas supply inlet of the one-touch connector type aspirator is $\phi 6$, and the gas outlet is $\phi 8$. Do not confuse the supply inlet and gas outlet when you connect the aspirator.

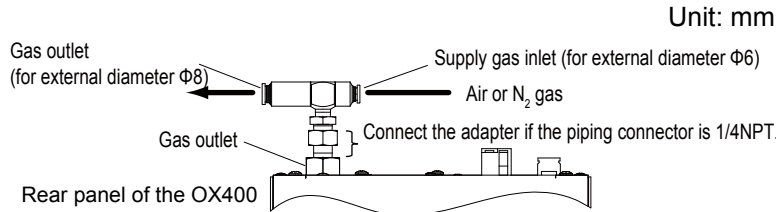

Figure 6.18 Example of Connecting Aspirator and Gas Piping

Figure 6.19 shows the relationship between the supply pressure, suction gas flow rate, and total discharge gas flow rate of the aspirator.

The air supply pressure to the aspirator shall be in the range between 65 and 100 kPaG. Also, maintain the air supply pressure at a certain value to prevent the pressure from fluctuating. If the pressure fluctuates, the suction flow rate fluctuates resulting in a fluctuation of measured data. The allowable pressure fluctuation range is the set pressure ± 2 kPaG. Furthermore, the outlet pressure shall be equal to the atmospheric pressure. Also make sure back pressure is not applied.

Check the sample gas flow rate, and adjust it to 200 ± 25 mL/min (a floater should be on the bar of the 200 mL/min bar on flowmeter) using the throttle knob on the front panel after adjusting the air supply pressure to the aspirator.

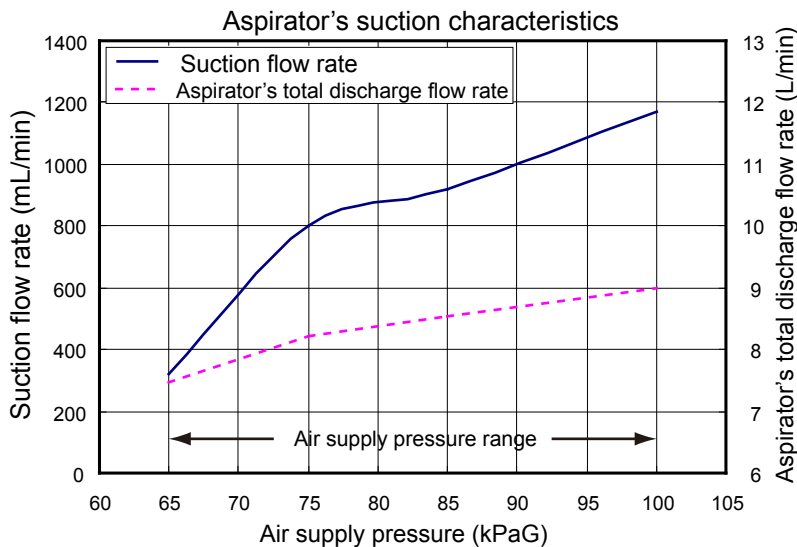

Figure 6.19 Aspirator's Suction Characteristics

6.5 Switching Measurement Flow Path Using Multi-Selector

This item is an option, so if you did not specify option “/MS,” this function does not work.

When oxygen concentration at multiple locations is measured, the multi-selector allows switching of measurement flow path using the relay contact output. Three gas flows can be switched from the panel.

Specify the flow path No. (“1” through “3”) in the maintenance mode “MLS.” The default in “MLS” is “0.” For details, see Section 6.1.9, “Setting Multi-Selector “MLS.”” Furthermore, output of measurement flow path data can be performed by combining two contacts.

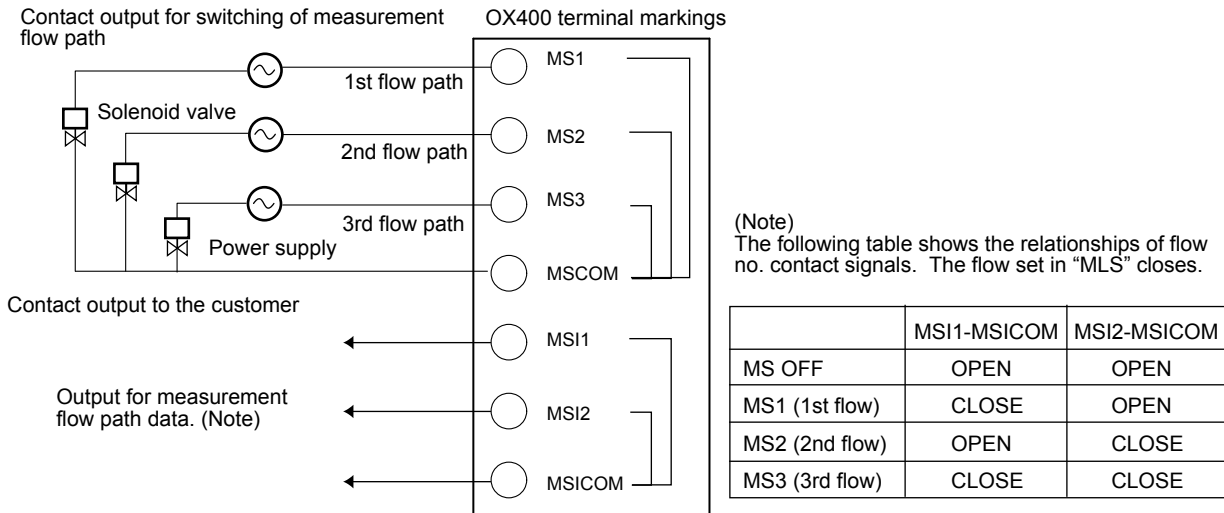

Figure 6.20 Switching Measurement Flow Path Using Multi-Selector (Example of Three Gas Flows)

When the multi-selector is used, the flow path “MLS1” through “MLS3” under measurement are displayed on the sub-display on the front panel. If an error or alarm occurs while the multi-selector is used, the flow path No. and error/alarm are displayed sequentially.

6.6 Numerical Value, Decimal Point, and Unit Input Operation

Figure 6.21 shows an example of operation to input a numerical value, decimal point, and unit. Italic characters indicate the flashing state.

Numerical value input

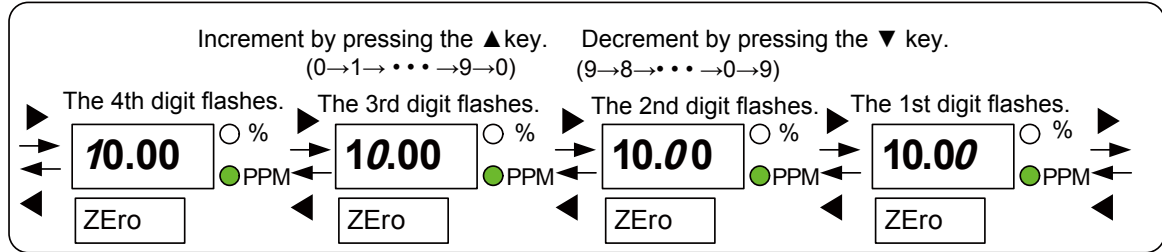

Decimal point and unit input

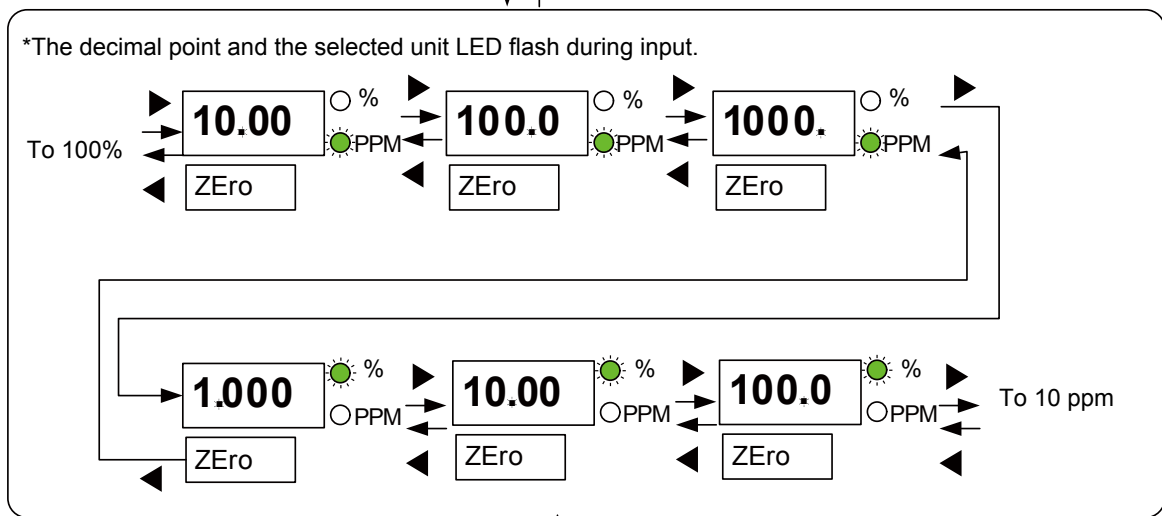

[ENT] ↓
Input is confirmed.

Figure 6.21 Example of Operation to Input Numerical Value, Decimal Point, and Unit

7. Inspection and Maintenance

Routine inspection and maintenance is important to ensure operation of the OX400 in a good condition. Perform regular inspection and maintenance in accordance with the following instructions.

7.1 Routine Inspection and Maintenance

(1) Checking readings

Measure calibration gas about once every two to three months and check the readings. If an error is found with the calibration gas concentration, perform zero-span calibration in the range you use.

(2) Checking gas flow rate

Regularly check the sensor gas flow rate in order to make sure that the flow rate is 200 ± 25 mL/min (a floater should be between upper and lower bar of the 200 mL/min bar on flowmeter).

(3) Other

Regularly check for signs of malfunction such as strange noises of the pump and fan, or unusually high temperature of the case.

(4) Replacing the fuse

Be sure to turn off the power of the OX400 and remove the power plug from the socket before replacing the fuse. The fuse is installed in the lower part of the power cord plug on the rear panel of the OX400 (see right figure). Remove the power cord from the plug, pull the fuse holder out of the lower part of the plug, replace the fuse with a new one, and push the fuse holder back in place. Be sure to replace the old fuse with a correctly rated one.

If a replaced fuse burns out soon, the circuit is likely to be defective. Please contact our service department.

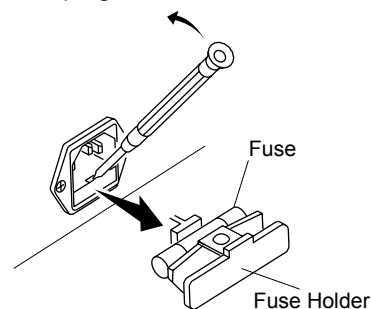

7.2 Inspection in the Event of an Error

If an error occurs, the ERR/ALM lamp on the front panel turns on. An error/alarm code is displayed on the sub-display. If multiple errors occur, codes are displayed in the order of occurrence.

An error means a malfunction, so the heater is turned off and the measurement is stopped. When an error occurs, repair is required. On the other hand, an alarm means a warning, so measurement is continued. An alarm occurring during calibration may invalidate the calibration depending on the content of the alarm.

The following shows the display and output in the event of an error/alarm.

Notice Event	Front Panel		Rear Panel		
	LED lamp	Sub-display	FAIL contact	DO contact	mA output
Error occurs	● ERR/ALM On	[ErrX] Err code	CLOSE	OPEN	Scale-out by burnout
Alarm occurs	●● ERR/ALM Flashing	[ALMX] ALM code	OPEN	Closed only in the event of "ALM7"	Measurement output

(Note) When burnout function is disabled, the mA output in the event of an error (fail) is "4 mA."
 Furthermore, the mA output during warm-up is also "4 mA."
 FAIL (error) contact and DO (alarm) contact are "OPEN" when the power is OFF.

7.2.1 Inspection in the Event of an Alarm (ALM)

If an error is detected by the self-diagnosis function of the OX400 during operation, the ERR/ALM lamp flashes and an alarm (ALM) code is displayed on the sub-display. If an error is detected, take action according to the Table 7.1.

Table 7.1 Alarm (ALM) Conditions and Actions

Display	Content	Diagnosis Condition	Action
ALM1	Unstable heater temperature	The heater temperature changed by $\pm 5^{\circ}\text{C}$ or more from the standard temperature.	Check to make sure the sensor gas flow rate or power supply is not unstable
ALM2	Sensor error	The sensor electromotive force during calibration became greater than $\pm 30\%$ relative to the standard.	Check the calibration gas O ₂ concentration value Re-calibrate Replace the sensor
ALM3	Electromotive force error	A sensor electromotive force error of ± 15 to $\pm 30\%$ relative to the standard occurred during calibration.	Check the calibration gas O ₂ concentration value Re-calibrate Replace the sensor
ALM4	Asymmetric voltage error	The air electromotive force became greater than ± 10 mV during calibration. Calibration up to ± 30 mV is possible. Calibration beyond ± 30 mV is not possible.	Check the air concentration Re-calibrate Replace the sensor
ALM5	Calibration error	The calibration coefficient became greater than the specified values (zero: ± 50 , span: 1 ± 0.2). When zero is ± 50 to ± 75 and span is 1 ± 0.2 to 1 ± 0.4 , calibration is possible When zero exceeds ± 75 and span exceeds 1 ± 0.4 , calibration is not possible	Check the calibration gas O ₂ concentration Re-calibrate Replace the sensor
ALM6	Sensor resistance value error	The sensor impedance (cell resistance value) became greater than 1 k Ω during calibration.	Prepare a replacement sensor
ALM7	Oxygen concentration high/low limit error	The oxygen concentration became larger than the high/low limits.	Change the high/low limits as needed
ALM8	Over range error	The oxygen concentration became greater than 100%FS, or became a negative value.	Change the range Re-calibrate

7.2.2 Inspection in the Event of an Error (ERR)

If an error is detected during operation, the ERR/ALM lamp turns on and an error (ERR) code is displayed on the sub-display. If an error is detected, take action according to Table 7.2.

Table 7.2 Error (ERR) Conditions and Actions

Display	Factor	Diagnosis Condition	Action
Err1	Sensor failure	Sensor burnout. The sensor electromotive force became less than -50 mV.	Replace the sensor
Err2	Heater temperature error	The heater temperature became greater by $\pm 30^{\circ}\text{C}$ relative to the standard temperature.	Replace the heater Check the temperature adjustment circuit (Contact our service department)
Err3	Temperature sensor burnout	The temperature sensor has burned out.	Replace the heater (Contact our service department)
Err4	OX400 temperature error	The temperature inside the OX400 became greater than 70°C .	Check to make sure the ventilation holes, cooling fan outlet, and line are not blocked, lines are not blocked, and so on. Turn the power off and then on.
Err5	CPU failure	A CPU failure occurred.	Contact our service department.
Err6	Fan stop	The cooling fan stopped.	Contact our service department.

Note: If an error (ERR) occurs, the heater is turned off. To clear the error, you need to turn the power off and then on. It is recommended to turn the power off and then on to see whether the error occurs again. Be careful because if the power of the OX400 is turned off, the contact output "OPEN."

7.3 How to Replace Sensor

When the sensor has deteriorated, replace it with a new sensor. As for the part number, see CMPL at the end of this manual. Be sure to perform calibration after replacing the sensor.

Replace the sensor according to the following instructions.

7.3.1 Removing Sensor

- (1) Turn off the power, and be sure to pull the power cord out of the socket.
- (2) Wait for about 1.5 hours until the heater temperature falls to the ambient temperature level.

 **WARNING**

Be sure to replace the sensor after the heater temperature has fallen sufficiently. Not doing so may cause burn injuries.

- (3) To remove the upper cover, remove set screws at three points on the rear panel of the OX400.
- (4) Slide the upper cover backwards and remove it upwards.

Remove the three screws and slide the upper cover backwards.

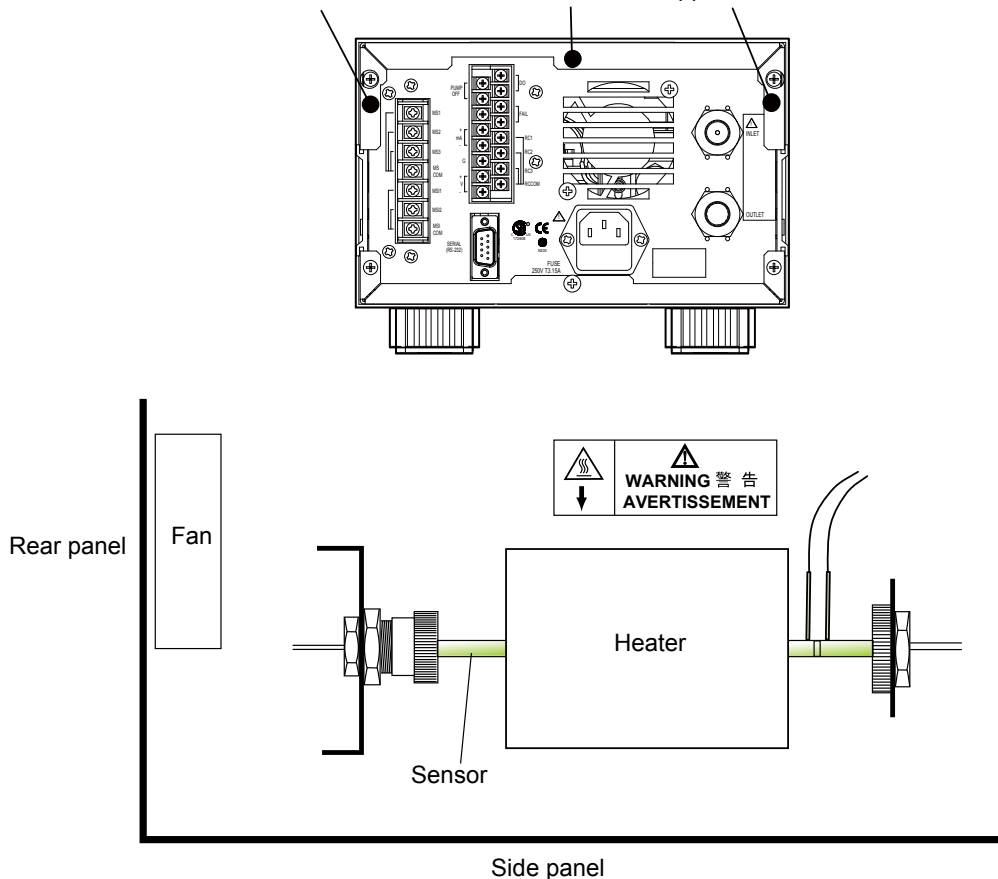

When the upper cover has been removed, you can see the heater sensor.

Figure 7.1 Removing Cover

- (5) Remove the lead wire connector of the sensor from the PCB board.
- (6) Loosen the joint ring ① on the sensor outlet side and remove it towards the heater side.

- (7) Pull out the joint ② while holding the sensor.
- (8) Rotate the inlet-side joint nut ③ counter clockwise seen from the heater side and remove it.

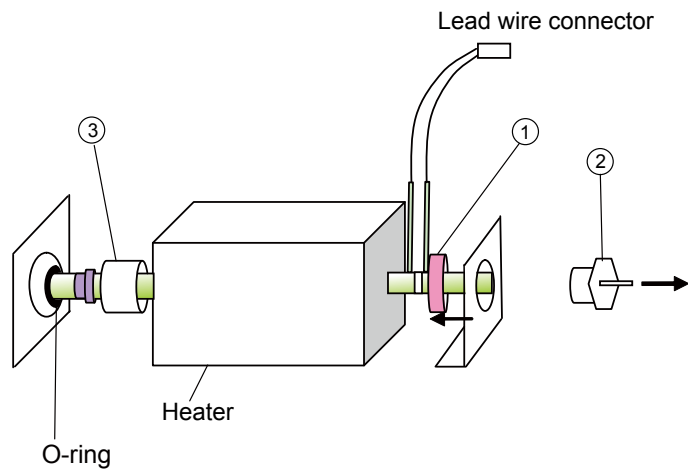
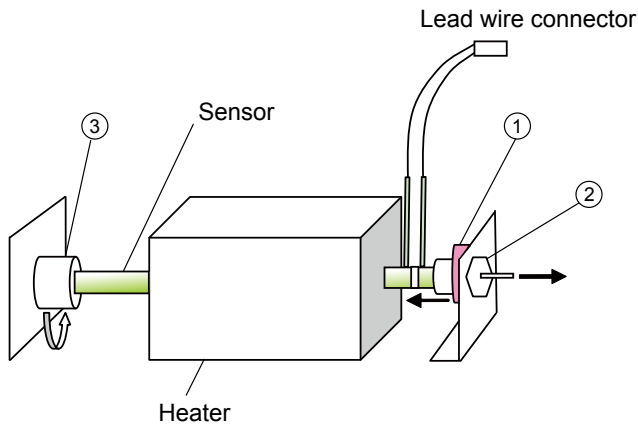

- (9) Pull out the holding plate ④, remove the ring ①, and pull the sensor out of the heater straightforward.

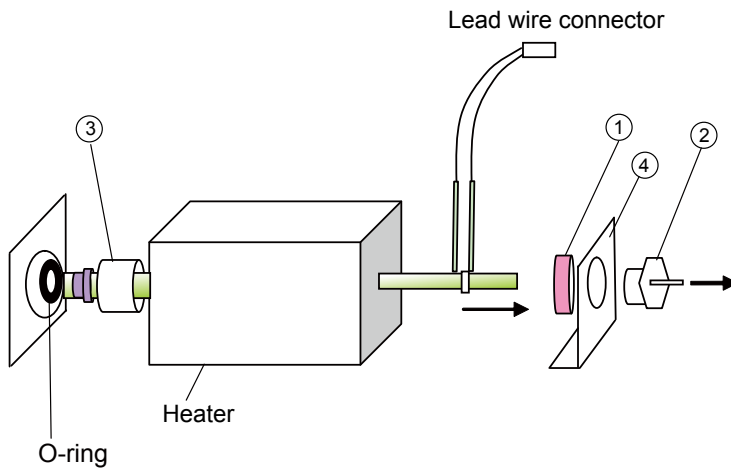
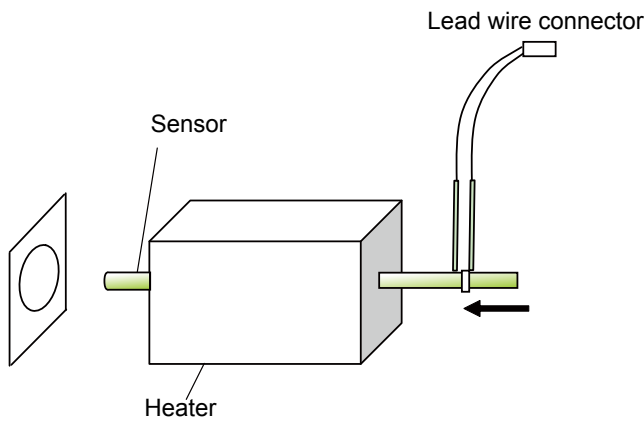

Figure 7.2 Removing Sensor

7.3.2 Installing Sensor

- (1) Pass a new sensor through the heater.



- (2) Insert the nut ③, holder ⑤, and O-ring ⑥ in this order from the front end of the sensor. At this point, set the O-ring in the position about 3 mm from the sensor front end (It is recommended to replace the O-ring with a new one).

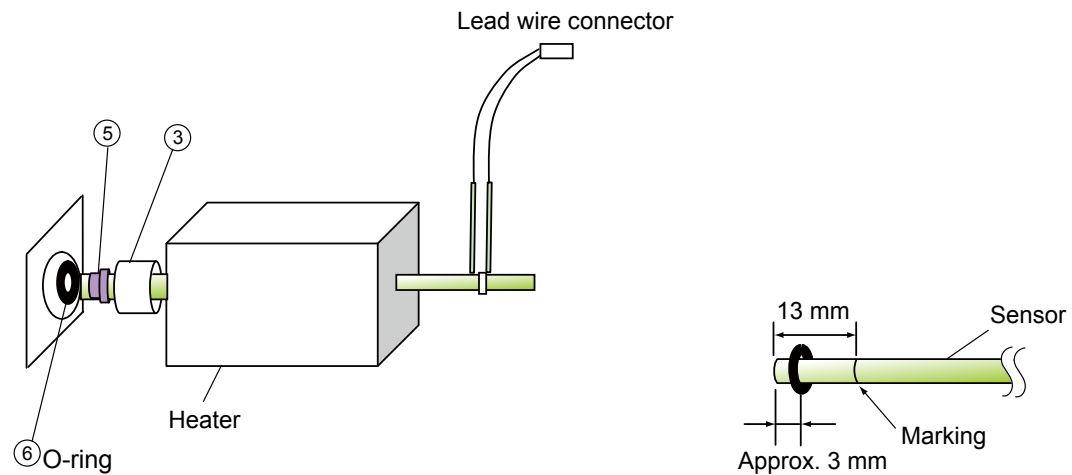

- (3) Insert the sensor into the connector and tighten the nut ③ firmly with fingers. At this point, make sure that the lead wire of the sensor is located in the upper right position.

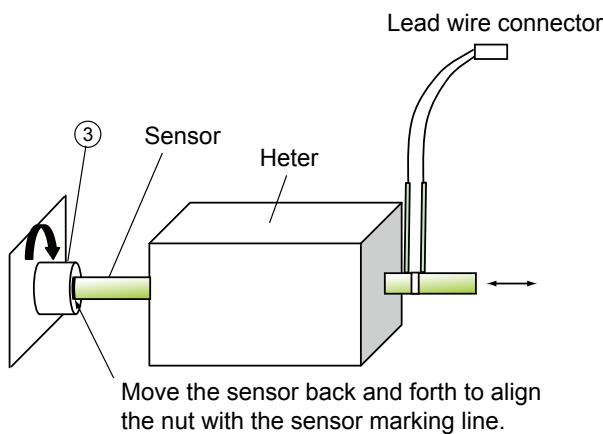
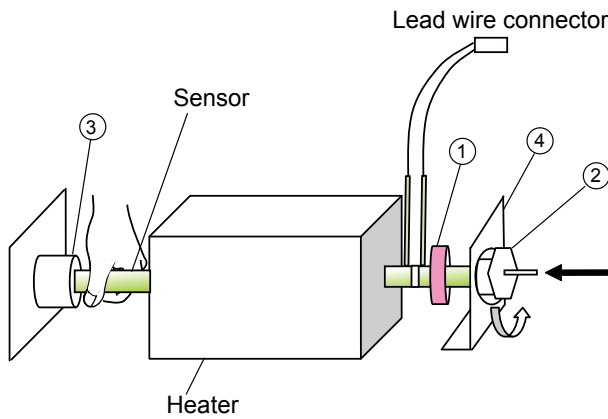

Figure 7.3 Installing Sensor

- (4) Insert the ring ① and holding plate ④ in this order into the sensor. Hold the sensor with fingers and rotate the joint ② right and left to push it into the sensor slowly.



- (5) Rotate and tighten the ring ① into the joint ②. Secure the holding plate ④ with two screws (7).

Connect the lead wire connector of the sensor to the PCB board.

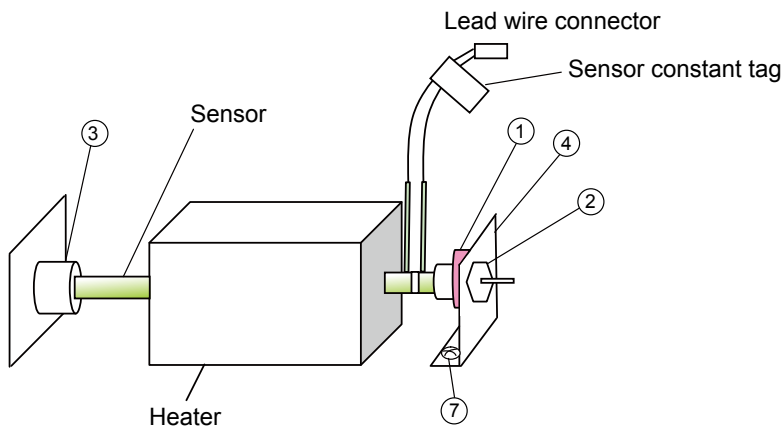

- (6) When the installation of the sensor is finished, take a note of the sensor constant on the sensor constant tag attached to the sensor lead wire, and then close the cover.
- (7) Turn on the power, and when “HEAt” appears and countdown starts, enter sensor constant “SEnS.” As for how to enter it, see 6.1.7 “Setting Sensor Constant.”

Be sure to perform calibration after replacing the sensor.

7.4 How to Replace Activated Carbon Filter

Activated charcoal filter will be provided when "/A" option is specified. Filter should be installed between gas sampling line and gas inlet of OX400. Filter has a life time and need to replace periodically, its replacement interval vary depending on the application. As for the part number, see CMPL at the end of this manual.

- (1) Loosen the four screws with washers (B) of holder (A) and remove holder (A). (Figure 7.4)
- (2) Remove cotton filter (C), felt filter (D), and O-ring (E).
- (3) Dispose of activated carbon (F).

Remove the bottom side holder same as the upper side holder and pull out the activated carbon. Referring item (5) to (7), set the bottom side holder.

- (4) Fill the case with approximately 9 grams of new activated carbon up to approximately 8 mm from the upper surface of the case. Shake the case gently to fill the interstices of the activated carbon.
- (5) If the removed felt filter (D) is dirty, replace it with a new one. Set felt filter (D) onto the activated carbon (F) so that the laminate surface faces activated carbon (F).
- (6) If cotton filter (C) is dirty, replace it with a new one. Set a 0.2 gram cotton filter onto felt filter (D).
- (7) Align O-ring (E) with groove (1) and secure holder (A) with screws with washers (B).



CAUTION

Tightly close the lid of the replacement activated carbon case and store it in an indoor location where it will not be subject to humidity and direct sunlight.

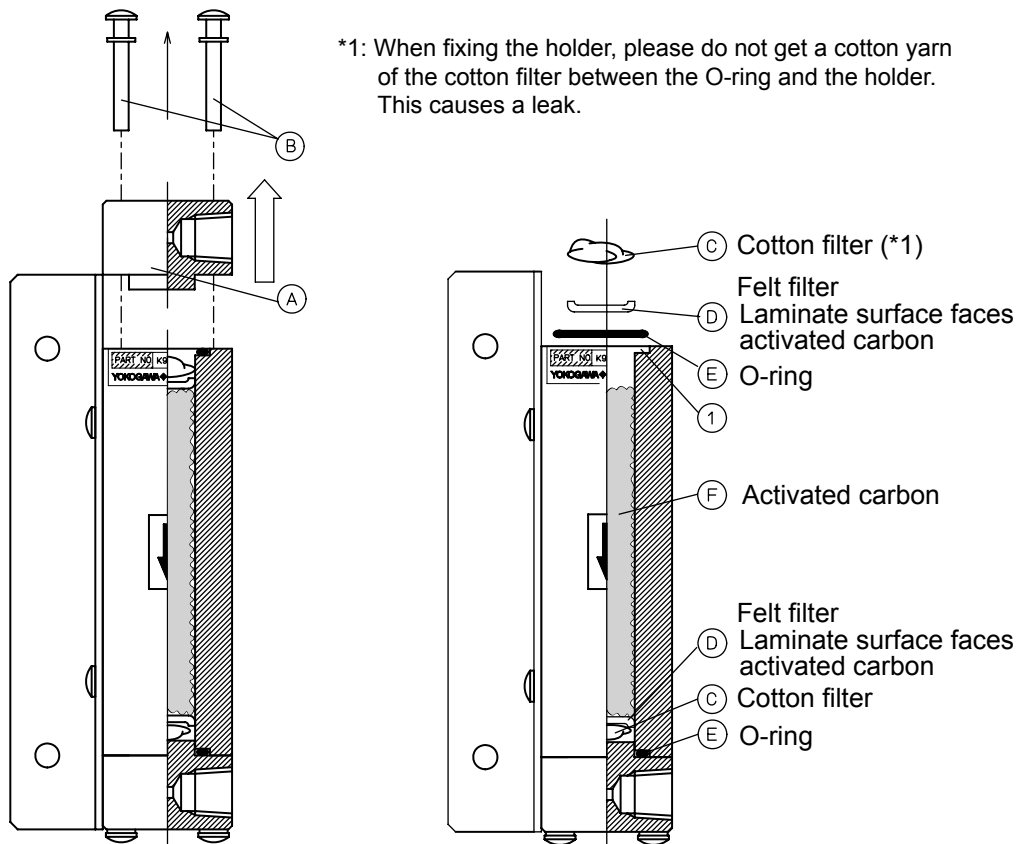

Figure 7.4 How to Replace Activated Carbon

7.5 How to Replace the Line Filter

The line filter is inside the gas inlet connector on the rear panel. The line filter is covered by a plate, and both these parts are held in place by a C-shaped snap ring. The following explains how to replace the line filter. This requires a pair of snap ring pliers and some tweezers.

- (1) Insert the tips of the snap ring pliers in the holes on the snap ring and apply pressure to release and remove the snap ring.
- (2) With the tweezers, remove first the plate and then the filter.
- (3) Attach the new filter, plate, and snap ring in this order.
 - Insert the filter into the connector with the smooth side facing up.
 - Place the plate over it with the fine mesh side facing down.
 - With the snap ring pliers, apply pressure to insert the snap ring, and hold down and secure the filter and plate in place with the snap ring. At this point, make sure you attach the snap ring firmly in place so that the plate is secured enough that it cannot be moved even if an attempt to move it with tweezers is made.



CAUTION

The snap ring must be securely attached to firmly hold the filter and plate in place. Otherwise, the filter will not function correctly.

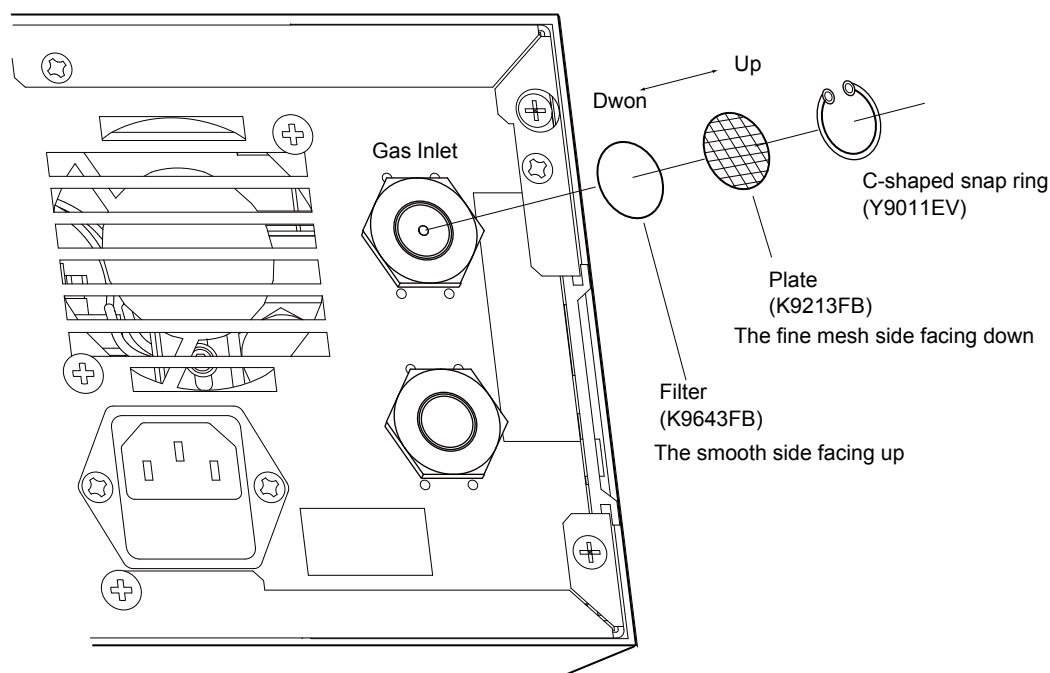

Figure 7.6 How to Replace the Line Filter

8. Appendix

8.1 Parameter Settings

Table 8.1 Parameter Setting List (Customer Settings)

Menu	Parameter 1	Parameter 2	Parameter 3	Function detail	Defaults	Description	Customer Settings	Reference section	
Output range (4-20 mA DC)	"mG"	"Auto"		Auto range	"1"	(Note 1)			
		"MAN"		Manual range	0-1000 ppm				
		"FREE"		Partial range	0-1000 ppm				6.1.1
			"Fr.Lo"		Low limit	0 ppm			
		"Fr.Hi"		High limit	1000 ppm				
Secondary output	"oUt2"	"1" / "5" / "10"		Voltage output	"1"	0-1V DC		6.1.2	
Hold function	"HoLd"	"non" / "PREV"		Previous or non	non	Non hold		6.1.3	
Burnout function	"nAMU"	"non" / "Er.Lo" / "Er.Hi"		Hi/Low/non	non	Non burnout		6.1.4	
O ₂ conc. Hi/Low alarm	"ALM"	"oFF"		Non alarm					
		"ALL"	"AL.Lo"	Low limit					
			"AL.Hi"	Hi limit	Hi limit	oFF	Non alarm		6.1.5
		"AL.Lo"		Low limit only					
Calibration gas concentration	"SET.C"	"1Pnt"		1 point	1000 ppm	Cal-gas conc. (Note 2)			
			"2Pnt"		2 points				
		"Zero"			Zero-gas conc.	100.0 ppm	(Note 3)		
			"SPAN"		Span-gas conc.	1000 ppm	(Note 4)		6.1.6
		"ALL"		3 points					
			"10"		10 ppm gas conc.	10.00 ppm	(Note 5)		
	"1000"		1000 ppm gas conc.	1000 ppm	(Note 6)				
Output smoothing	"SMoo"	"0 to 60"		Smoothing factor.	0 sec	Non (Note 7)		6.1.8	
Multi-selector	"MLS"	"0" / "1" / "2" / "3"		Flow path No.1 to 3	"0"	Non use		6.1.9	

(Note 1) Auto Range between 0-10 ppm, 0-100 ppm, 0-1000 ppm, 0-1%, 0-10%, and 0-100%.

(Note 2) Calibration gas concentration input range: 0.90 ppm to 12.00%, 35.00% to 100.0%. Gas concentration can also be set from "CAL" calibration.

(Note 3) "Zero" input range: 1.00 ppm to 100.0%. Gas concentration can also be set from "CAL" calibration.

(Note 4) "SPAN" input range: 1.00 ppm to 100.0%. Input is not possible if the smallest span is less than 20% of the range after inputting "SPAN." Gas concentration can also be set from "CAL" calibration.

(Note 5) Calibration gas concentration input range: 8.00 to 20.00 ppm. Gas concentration can also be set from "CAL" calibration.

(Note 6) Calibration gas concentration input range: 800 to 2000 ppm. Gas concentration can also be set from "CAL" calibration.

(Note 7) If the output smoothing is set, the smoothed value becomes an instantaneous value which is displayed and output in analog format. The smoothed value is also used as the instantaneous value (measured value) for checking concentration alarms and RS232 communication.

(Note 8) Set parameters will not be erased by turning the power off and on.

Blank Page

Customer Maintenance Parts List

OX400 Low Concentration Zirconia Oxygen Analyzer [Style: S2]

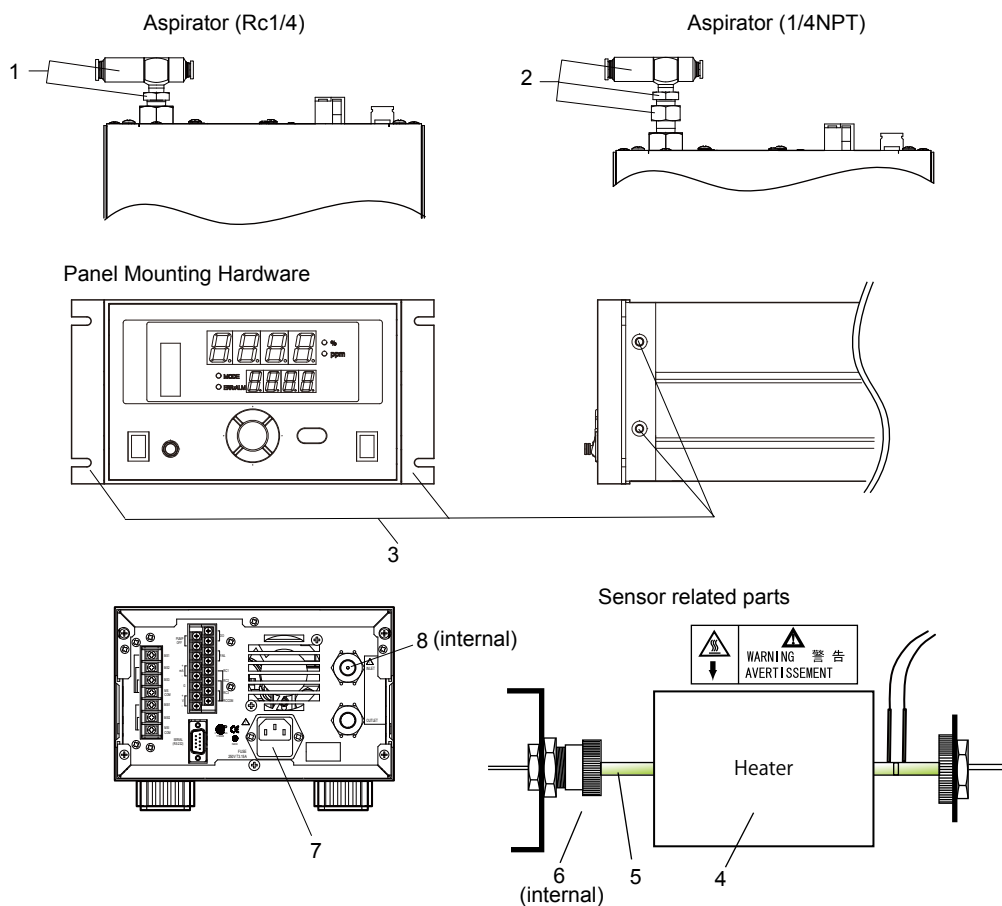

Item	Part No.	Qty	Description
1	K9643KA		Aspirator Assembly (Rc1/4)
	K9643WK	1	Aspirator
	G7010XA	1	Bushing
2	K9643KB		Aspirator Assembly (1/4NPT)
	K9643WK	1	Aspirator
	G7010XA	1	Bushing
	G9612CK	1	Connector
3	K9643KC		Panel Mounting Hardware Assembly
	K9643GM	1	Frame (left-side)
	K9643GN	1	Frame (right-side)
	Y9514EU	4	Screw
*4	—		Heater Assembly
5	K9643KG	1	Sensor Assembly with O-ring
6	K9643WR	1	O-ring
7	A1113EF	1	Fuse (250V T3.15A)
8	—		Line Filter
	K9643FB	1	Filter
	K9213FB	1	Plate
	Y9011EV	1	Snap Ring (Retainer)
	K9643ZE	1	Snap Ring Plier (Tool to remove snap ring)

* Do not exchange these parts. Call service personnel.

Activated Carbon Filter (Option code "/A")

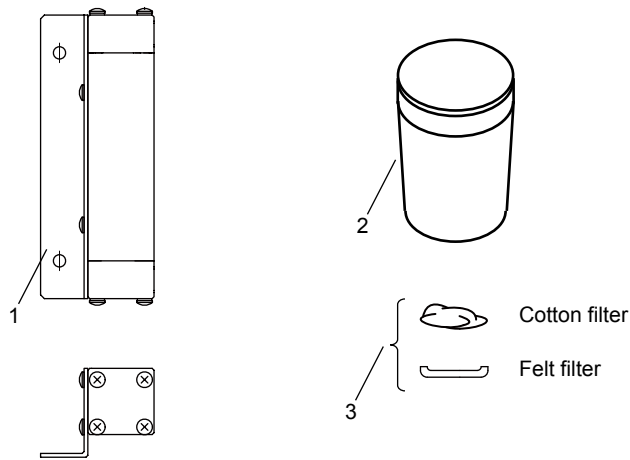

Item	Part No.	Qty	Description
1	K9643KH	1	Filter Assembly (Rc1/4)
	K9643KJ	1	Filter Assembly (1/4NPT)
2	K9643KK	1	Activated Carbon Filter Element Kit (15 times replacement)
3	K9643KL	1	Filter Kit (5 times replacement)

Revision Information

● Title : Model OX400 Low Concentration Zirconia Oxygen Analyzer [Style: S2]

● Manual No. : IM 11M10B01-01E

Aug. 2015/4rd Edition

P 2-3, Section 2.1, "Standard Specifications" Conformance to Safety and EMC standards:
Added of KC Marking and some spell error corrections and addition of specification description.
P 2-4, Section 2.3, "Model and Suffix Codes" Note 2: Addition of the description.
P 2-5, Section 2.4 "Consumables" K9643FB: Deleted the asterisk.
P 6-1, Section 6, "Operation and Parameters" Figure 6.1: Changed of parameters cord.
P 6-7, Section 6.1.7, "Setting Sensor Constant "SEnS" ": Changed the parameters cord of
description and figure 6.8.
P 6-9, Section 6.1.9, "Setting Multi-Selector "MLS" Figure 6.11: Changed of parameters code.
P 6-12, Section 6.3, "Communication" • Communication Specifications: Added of figure.
P 7-7, Some coments added.

May. 2011/3rd Edition

P 2-1, Some revision of output range description (auto range modified); P 2-4, Some revision of MS-code description ("F" changed to "A" for activated carbon filter); P 2-5, Some revision of Consumable (Parts for "A" activated carbon filter added); P 2-9, Some revision of External Dimensions (for "A" activated carbon filter); P 3-4, Some revision of dimensions on Figure 3.3 (for "A" activated carbon filter); P 4-4, Some revision of Table 4.2 Range Marker (auto range modified); P 6-2, Some revision of Auto Range description on subsection 6.1.1 (How to set range code modified); P 7-7 Some revision of Subsection 7.4 "How to Replace Activated Carbon, Felt Filter, and Cotton Filter" (for "A" activated carbon filter); CMPL 11M10B01-02E, revised to 2nd edition (for "A" activated carbon filter).

Nov 2010/2nd Edition (Style changed to S2)

P i INTRODUCTION, Caution mark added to Safety explanation; P 2-1, Some revision of aspirator suction condition; P 2-2, Some revision of power supply and consumption; P 2-3, Some revision of Conformance to Safety description (CSA certified); P 2-4, Some revision of MS-code description; P 2-5, Some revision of Consumable (Parts for Line Filter added); P 2-6, Some revision of External Dimensions (Ventiration holes modified); P 2-7 to P 2-8, Some revision of external dimensions (rear panel modified); P 2-11, Some revision of Wiring Diagram (Caution for power cord modified); P 3-2 to 3-3, Some revision of dimensions on Figure 3.1 to 3.2 (Ventiration holes modified); P 4-2, Some revision of Figure 4.2 (rear panel modified); P 4-3, Some revision of Figure 4.3 Wiring Diagram (Caution for power cord modified); P 4-5, Some revision of Figure 4.4 (rear panel modified); P 5-1, Some revision of Flowmeter description (How to adjust modified); P 5-3, Some revision of Figure 5.3 (rear panel modified); P 6-2, Some revision of Flowmeter description on subsection 6.1 (How to adjust flow rate modified); P 6-14, Some revision of Flowmeter description on subsection 6.4 (How to adjust flow rate modified, some revision of Figure 6.19); P 7-1 Some revision of Checking gas flow rate description on subsection 7.1; P 7-3, Some revision of Figure 7.1 (rear panel modified); P 7-5, Some revision of sec. 7.3.2 Installing Sensor (rmarked line added to sensor assembly); P 7-8, Subsection 7.5 "How to Replace the Line Filter" added; CMPL 11M10B01-02E for Style S2 newly published.

Jun. 2009/1st Edition

Newly published

-
- If you want to have more information about Yokogawa products, you can visit Yokogawa's home page at the following web site.
Home page: <http://www.yokogawa.com/an>
-

