

INSTRUCTION MANUAL
 **DIGITAL LEVEL**

DL-103 SERIES
DL-103AF

Foreword

Thank you for purchasing the TOPCON Electronic Digital Level DL-103 series. For the best performance of the instruments, please carefully read these instructions and keep them in a convenient location for future reference.

EXCEPTIONS FROM RESPONSIBILITY

- 1)The user of this product is expected to follow all operating instructions and make periodic checks of the product's performance.
- 2)The manufacturer, or its representatives, assumes no responsibility for results of a faulty or intentional usage or misuse including any direct, indirect, consequential damage, and loss of profits.
- 3)The manufacturer, or its representatives, assumes no responsibility for consequential damage, and loss of profits by any disaster, (an earthquake, storms, floods etc.).A fire, accident, or an act of a third party and/or a usage any other usual conditions.
- 4)The manufacturer, or its representatives, assumes no responsibility for any damage, and loss of profits due to a change of data, loss of data, an interruption of business etc., caused by using the product or an unusable product.
- 5)The manufacturer, or its representatives, assumes no responsibility for any damage, and loss of profits caused by usage except for explained in the user manual.
- 6)The manufacturer, or its representatives, assumes no responsibility for damage caused by wrong movement, or action due to connecting with other products.

GENERAL HANDLING PRECAUTIONS

1) Staff

Precautions are needed to avoid to be dirt or hurt of Pattern Staff surface or connected part of each staff.

The pattern surface or the connected part is possible to be touched and injured on the occasion of storage or transportation.

If the patterns dirtied or injured, accurate read out or measurement can not be expected because the instrument reads out the white and black patterns of the staff as electrical signals. Otherwise the quality of accuracy of the instrument reduces or sometimes measurement can not be done.

2) Tripod

The screws on each leg of the tripod must be tightened firmly.

3) On tribrach

If tribrach is not installed correctly, measuring precision may be effected. Occasionally check adjusting screws of the tribrach . Tighten the Base Fixing Screw.

4) Guarding the instrument against shocks

When transporting the instrument, provide some protection to minimize risk of shocks. Heavy shocks may cause the measurement to be faulty.

5) Carrying the instrument

When carrying the instrument at the site, always grip its handgrip.

6) Do not expose the instrument directly to the sunlight

Never leave the instrument in extreme heat (+122 degrees F) longer than necessary. Heat can adversely affect its performance. Never expose the instrument's objective lens to direct sunlight without a filter. Sunlight may damage the components inside the instrument.

7) Sudden changes of temperature



Any sudden change of temperature to the instrument may result in a reduction of the measuring range. When taking the instrument out from a heated vehicle let instrument acclimate itself to the ambient temperature.

8) Battery level check

Confirm battery level remaining before operating.

DISPLAY FOR SAFE USE

In order to encourage the safe use of products and prevent any danger to the operator and others or damage to properties, important warnings are put on the products and inserted in the instruction manuals. We suggest that everyone understand the meaning of the following displays and icons before reading the “Safety Cautions” and text.

Display	Meaning
 WARNING	Ignoring or disregard of this display may lead to the danger of death or serious injury.
 CAUTION	Ignoring or disregard of this display may lead to personal injury or physical damage.

- Injury refers to hurt, burn, electric shock, etc.
- Physical damage refers to extensive damage to buildings or equipment and furniture.

SAFETY CAUTIONS

 WARNING
<ul style="list-style-type: none">• Cause eye injury or blindness. Do not look at the sun through a telescope.
<ul style="list-style-type: none">• Risk of fire or electric shock. Do not use a wet battery .
<ul style="list-style-type: none">• Battery can cause explosion or injury. Do not dispose in fire or heat.
<ul style="list-style-type: none">• May ignite explosively. Never use an instrument near flammable gas, liquid matter, and do not use in a coal mine.
<ul style="list-style-type: none">• The short circuit of a battery can cause a fire. Do not short circuit battery when storing it.
<ul style="list-style-type: none">• Keep the pattern staff away from electric facilities such as a high voltage wire or substation. As this is an electric conductor, there is danger of electric shock.
<ul style="list-style-type: none">• Do not use the pattern staff in conditions of thunder and lightning. As this is an electric conductor, thunderbolt can cause serious injury or death.

CAUTION

- Risk of injury by overturn the carrying case.
Do not stand or sit on the carrying cases.
- Please note that the tips of tripod can be hazardous, be aware of this when setting up or carrying the tripod.
- Risk of injury by falling down the instrument or case.
Do not use a carrying case with a damaged which belts, grips or latches.
- Do not allow skin or clothing to come into contact with acid from the batteries, if this does occur then wash off with copious amounts of water and seek medical advice.
- A plumb bob can cause an injury to a person if used incorrectly.
- It could be dangerous if the instrument falls over, please ensure you attach a handle to the instrument securely.
- Risk of injury by falling down a tripod and an instrument.
Always check that the screws of tripod are tightened.

USER

- This product is for professional use only!
The user is required to be a qualified surveyor or have a good knowledge of surveying, in order to understand the user and safety instructions, before operating, inspecting or adjusting.
- Wear the required protectors (safety shoes, helmet, etc.) when operating.

CONTENTS

STANDARD SYSTEM COMPONENTS	5
NOMENCLATURE AND FUNCTIONS	6
Nomenclature	6
Operating Keys and Functions	7
Display	8
PREPARATION FOR MEASUREMENT	9
Using the Battery Box	9
Setting Up the Instrument for Measurement	9
Focusing	12
Battery Supply Switch ON and Changing Mode	15
Battery Power Remaining Display	15
MEASUREMENT	16
Measurement Mode(Rod / Distance)	16
Height Difference Mode	17
Measuring a Horizontal Angle	18
SETTING MODE	19
Items of the setting mode	19
Setting Example	20
Data Format	21
CHECKING AND ADJUSTMENT	22
Adjustment of Circular Level	22
Adjusting Mode	23
ERROR ABOUT INSTRUMENT	25
OPTIONAL ACCESSORIES	26
SPECIFICATIONS	27

STANDARD SYSTEM COMPONENTS

1) Instrument DL-103AF (with lens cap)	1 pc.
2) Carrying case	1 set
3) AA dry battery	4 pc.
4) Silicon cloth	1 pc.
5) Plastic rain cover	1 pc.
6) Plumb bob set	1 set
7) Hexagon wrench	1 pc.
8) Instruction manual	1 vol.

Make sure that all of the above items are with the instrument when purchased.

NOMENCLATURE AND FUNCTIONS

Nomenclature

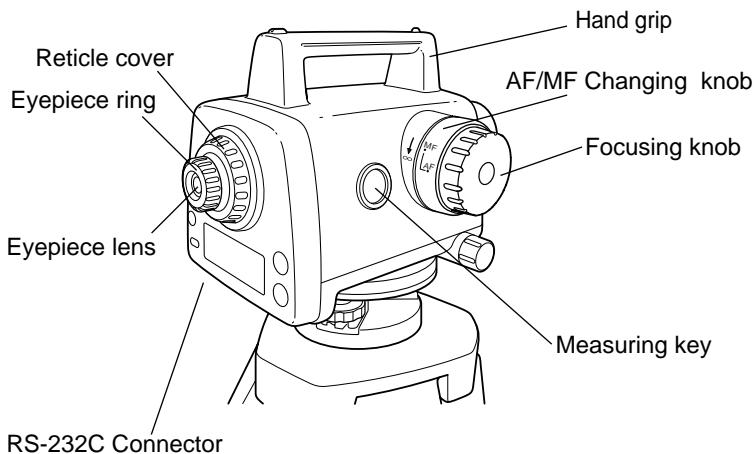
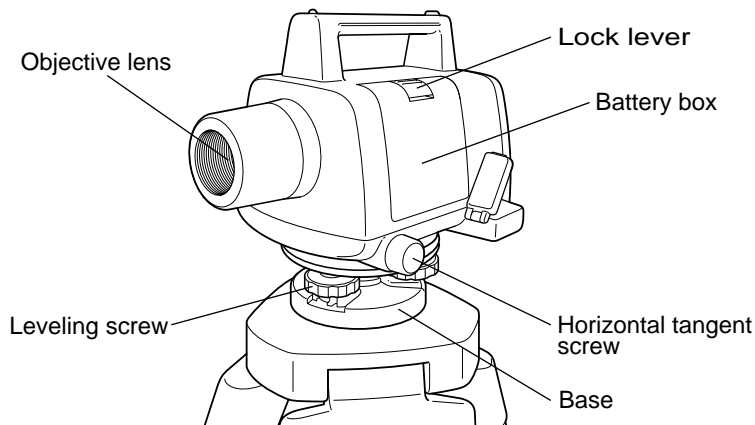

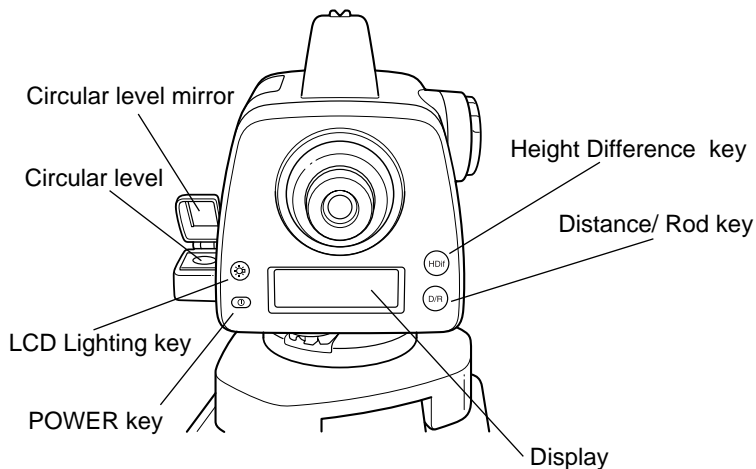

Operating Keys and functions

Key	Function
POWER key	Power supply is on or off.
Measuring key	Measurement is started.
HDif key	<ul style="list-style-type: none"> • Measurement mode and Height Difference mode is changed. • Measuring Height Difference, reference height is removed.
Distance/ Rod key	Distance and rod is changed.
LCD Lighting key	Display is lighted up for ten minutes.

Display

Display

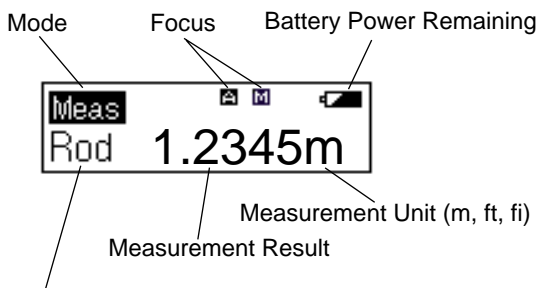

Rod	Staff reading
Dist	Distance
▲ or ▼	Height Difference

Mode

Display	Modes
Meas	Measurement Mode
HDif	Height Difference Mode
Adj	Adjustment Mode
Set	Set Mode

PREPARATION FOR MEASUREMENT

Using the Battery Box

How to remove the Battery Box

Push down the lock lever to remove the battery.

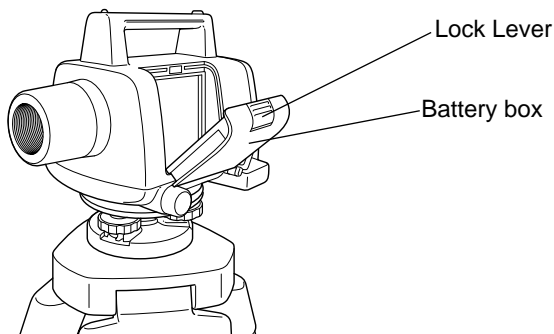

How to install the Battery

Install four AA dry batteries in the battery box referring to illustration of plus and minus.

How to install the Battery Box

Place the base of the battery box into the main body, push the battery box toward the instrument side till the battery clicks into position.

Setting Up the Instrument for Measurement

Setting up the Tripod

Use a tripod with a tripod screw of 5/8" diameter and 11 threads per inch.

- 1** Extend the legs to a suitable length and tighten the wing nuts at the legs mid-sections.
- 2** Tighten the hexagonal nut located on the side of the tripod head such that the tripod legs are not too loose. Place the tripod over the required point, with the legs spread about a meter apart or at such an angle to insure the stability of the tripod. Place one tripod leg in position and then use the other two legs to approximately level the tripod head. If necessary adjust the tripod leg extension.
- 3** Press the shoes of the tripod legs firmly into the ground to anchor the tripod securely.

Attaching the Instrument to the Tripod Head

Take the instrument carefully out of the carrying case and place it on the tripod head.

- 1** Align the tripod screw with the socket on the base of the instrument, and screw in the tripod screw until the instrument is securely fixed to the tripod head.
- 2** If the horizontal circle is being used for measuring an angle or establishing a line, the instrument must be set up exactly over the point with the plum bob.
- 3** Use the three leveling screws to center the circular bubble level in order to level the instrument. If a dome head tripod is being used, loosen the tripod screw slightly and move the instrument around on top of the tripod head to center the circular level bubble vial. When the bubble is within the red circle, tighten the tripod socket.

Setting the Instrument Up Over the Point

When the instrument is used to measure angles or to establish a line, the instrument must be set up exactly over a particular point with the plumb bob.

- 1** Hang the plumb bob hook on the plumb bob hanger of the tripod screw.
- 2** Next suspend the plumb bob string from the plumb hook and adjust the string length with the slipping device so that the plumb bob is at a suitable height.
- 3** If the instrument is not set up over the required point, move the instrument over the point without disturbing the relation between the tripod legs and the tripod head. Place the tripod in position so that the plumb bob is within one centimeter or so of the point. Grasp two of the tripod legs and adjust with respect to the third leg so that the tripod head is level at a convenient height with sufficient spread of the legs when the two legs are allowed to touch ground.
- 4** Finally press each leg firmly into the ground while watching the plumb bob and tripod head.
- 5** Loosen the tripod screw slightly and slide the instrument on the tripod head in order to position the plumb bob directly over the point and tighten the tripod screw.

Leveling the Instrument by the circular level

By using circular level mirror, the position of the bubble can be checked from the direction of the display.

- 1** Use the two leveling screws furthest from the circular level to move the bubble of the circular level vial. Rotate the screws in the direction which will shift the bubble of the circular level vial so that the bubble is located on a line perpendicular to a line running through the center of the two leveling screws being adjusted, as illustrated.
- 2** Next, revolve the remaining leveling screw to shift the bubble towards the center of the circular level vial.

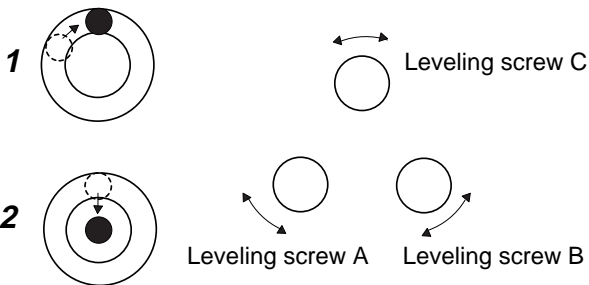

Focusing

You can select focusing method between manual or auto as showing illustrator for your device.

Changing AF/MF

To change AF to MF, push the AF/MF changing knob and turn to clockwise. The display shows “M” during measurement.

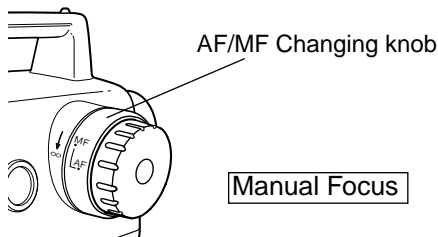

To change MF to AF, turn the AF/MF changing knob to the counterclockwise and pull it. The display shows “A” during measurement.

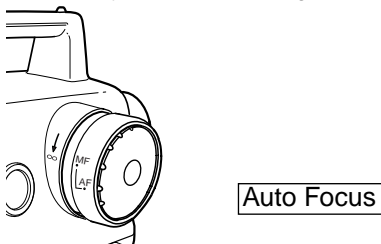

Also you can change focusing system from AF to MF or conversely during measurement.

Collimating

- 1** Point the telescope in the direction of the target. Sight through the telescope and align the target to the apex of the triangular mark as illustrated.
- 2** Next, revolve the focusing knob in either direction until the target is in focus.

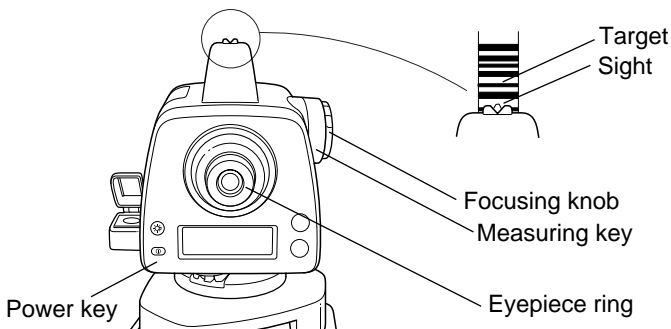

3 Adjust to be focusing

Manual focusing

Turn the focusing knob to fit to the staff line in manual focusing.

Auto focusing

Pressing measuring key after power ON, telescope will be focus to the staff line automatically.

4 Finally, use the horizontal tangent screw for precise alignment of the target.

- 1) You will find small gap in focusing image during Auto focusing in rare case, this is no problem in measuring accuracy.
- 2) Accurate focusing in manual focusing will help to be shorter for measuring time.

Note

Once the level has been focused and aligned on the target, shift the eye to the left and right while looking through the telescope eyepiece. There should be no deviation between the reticle cross-hairs and the target. If there is deviation, parallax, then either focus the instrument or adjust eyepiece.

Effective range of Auto focusing

Effective of Auto focusing range can be on the vertical line of cross hair in the telescope. Set the required target on the vertical line of cross hair.

Auto focusing using other than Pattern Staff

In case the target to be focused shows extremely small contrast between light and shade, focusing accuracy can be poor so it is better that you select high contrast as a target.

STAFF

Use a staff of TOPCON made by all means.

Obstructions

As long as the staff is not hidden by obstructions, such as tree branches by more than 30percent, measurement can be taken. Even if the point of intersection of the cross-hair is obscured, measurements can be taken if the obstruction covers less than 30 percent of the view.

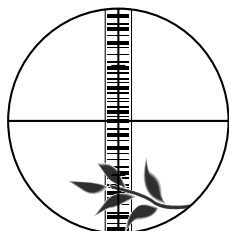

Measuring is possible

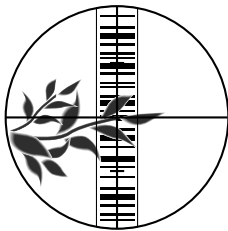

Measuring is possible

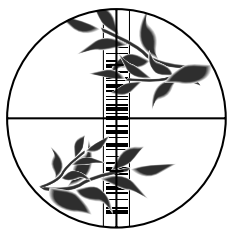

Measuring is impossible

Measurement is impossible even through the point of intersection of cross-hair is not hidden.

Shadow

It may not be possible to rarely measure when the staff is covered with a shadow as shown below. In that case, cover the whole of the staff with a shadow.

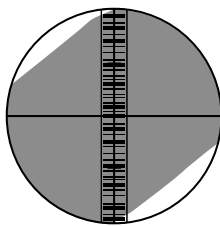
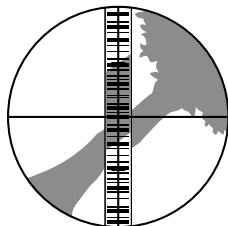

Cover the whole of the staff with a shadow.

Measuring Precaution

The followings are offered to take over full functions from the unit.

- 1** Set up the staff in the sufficient daylight. Even the illumination is used whole the staff should be illuminated.
- 2** The minimum distance possible measurement between instrument and staff is 2m.
- 3** No matter in measuring functions if the staff is in the shade, but if the scale pattern is covered by the shadow of tree branch or leaf, error may displays and measuring will be disturbed.
- 4** Precautions are needed to avoid to be dirt or hurt of Pattern Staff surface or connected part of each staff. When the staff becomes corrupt, wipe with a clean wet cloth after removing soil and the dust. Avoid the use of thinner or benzine.
- 5** Avoid waving of pattern staff in case electrical reading measurement. Use level of pattern staff.

Battery supply switch ON and Changing Mode

When the battery supply switch (power key) is ON , the display indicates measurement mode or height difference mode which is a state of the last time.





Changing Measurement Mode / Height Difference Mode.

Push the [HDif] key to change measurement mode and height difference mode each other.

Battery Power Remaining Display

Battery Icon

The battery icon displays the battery capacity.

-  The battery level is sufficient for measuring.
-  The battery level is sufficient for measuring.
-  The battery level is for measuring.
-  The battery will soon be discharged.
Charge to a new battery as soon as possible.

MEASUREMENT

Measurement Mode(Rod / Distance)

- 1 Check the instrument to be measurement mode.
Collimate the staff at the measuring point.
- 2 Push the [Meas] key.
Measurement is started.
(Then the instrument measures rod and distance at same time.)
After measurement is completed, a result is displayed.

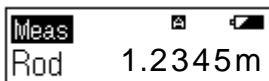
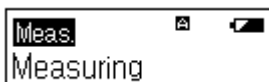

- 3 Push the [D/R] key to change the result to distance or rod.
The result is changed to distance or rod each other.

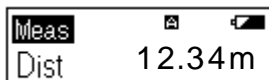

Height Difference Mode

- 1 By using the staff, measure the height of the reference point.

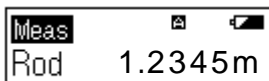

- 2 Push the [HDif] key to memorize the height of the reference point. Then the display indicates "Recorded".



- 3 Collimate the staff of next measurement point. Push the [Meas] key. After measuring, the height difference is displayed. Then the measurement point is higher than the reference point, ▲ mark is indicated. The measurement point is lower than the reference point, ▼ mark is indicated.

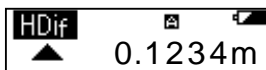

- 4 Push the [D/R] key, the display changes as follows.
HDif→Rod→Dist

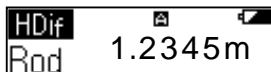

- 5 Press the [HDif] key to return Rod / Distance measurement.

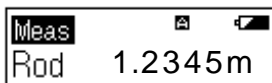

Measuring a Horizontal Angle

This instrument has a horizontal circle which can be used to measure horizontal angles. The horizontal circle is graduated in 1° (1g) divisions and is numbered every 10° (10g), with the scale calibrated from 0° to 350° (0 to 390g). The angular value increases as the instrument is revolved clockwise.

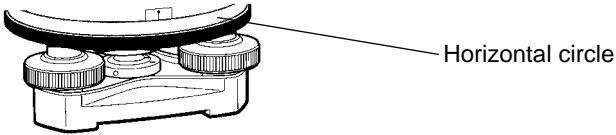

- 1 First, set up and level the instrument over the starting point, point C. Then sight through the telescope on the backsight, point A. Align the rod on point A precisely to the vertical cross-hair using the horizontal tangent screw. Rotate the horizontal circle ring until zero is set on the scale.
- 2 Next, sight through the telescope on the rod held on point B and precisely align with the horizontal tangent screw. The angular reading will be the horizontal angle between points A and B from point C, the angle ACB.

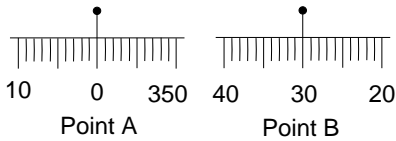
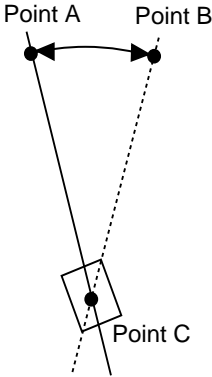

Degree type

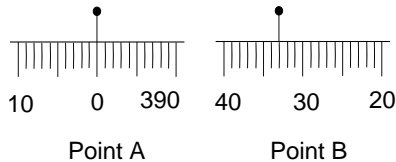

Grade type

Horizontal angle: 30° or 33g

SETTING MODE

Items of the setting mode

The following modes are available.
Refer to the next page to set the items.

Items	Selecting	Contents
Set Fix	Standard / Precise	Select the minimum reading Standard or Precise.
Display Unit	m / ft / fi	Select the distance measurement unit shown on the display.
RS-232C	ON / OFF	Select the RS-232C ON or OFF for data output.
Set Termination	CRLF ON / OFF	Select the option ON or OFF for termination code. (ON→ETXCRLF, OFF→ETX)
Auto Cut OFF	OFF / 30min.	The auto cut off option can be turned OFF or set ON (30 minutes).

Setting Example

Auto Cut OFF

- 1 While pressing the [D/R] key, press the power switch to set the indicator setting mode.
- 2 Press the [HDif] key to change the indicator “Auto Cut off”.

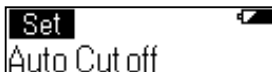

- 3 Press the [D/R] key. The position of the cursor indicates setting condition then.

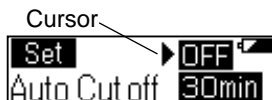

- 4 Press the [HDif] key to select “30min”. (In case of “OFF” is selected, auto cut off function is canceled.)



- 5 Press the [D/R] key to settle the term.
- 6 Turn the power switch off.

Display Unit

- 1 While pressing the [D/R] key, press the power switch to set the indicator set mode.
- 2 Press the [HDif] key to change the indicator “Display unit”.

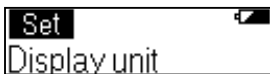

- 3 Press the [D/R] key. The position of the cursor indicates setting condition then.

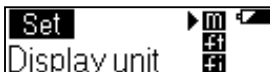

- 4 Press the [HDif] key to select “ft”.

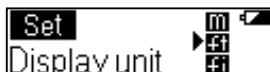

- 5 Press the [D/R] key to settle the term.
- 6 Turn the power switch off.

RS-232C

- 1 While pressing the [D/R] key, press the power switch to set the indicator set mode.
- 2 Press the [HDif] key to change the indicator "RS-232C".

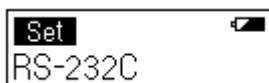

- 3 Press the [D/R] key. The position of the cursor indicates setting condition then.

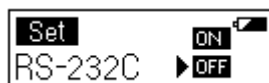

- 4 Press the [HDif] key to select "ON".

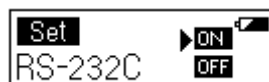

- 5 Press the [D/R] key to settle the term.
- 6 Turn the power switch off.

Data Format

Result of measurement can be transferred to PC from DL-103AF. To transfer the Rod and Distance data, DL-103AF should be set RS-232C on and the measurement mode (Rod / Distance). Character format is fixed.(except termination code)

Baud rate	1200BPS
Start bit	1bit ("0"=high)
Data bit	7bit ("0"=high, "1"=low)
Parity	even number ("0"=high, "1"=low)
Stop bit	1bit ("1"=low)
Termination code	ETX / ETXCRLF

For more information about connecting with the instrument, refer to DL-103 interface manual .

Checking and Adjustment

Adjustment of Circular Level

Check

- 1** Set the instrument on the tripod and carefully center the bubble of the circular level with the three leveling screws.
- 2** Revolve the telescope 180° around its vertical axis. If the bubble moves from the center, adjustment must be made as follows.

Adjustment

- 1** First, pick the level vial adjust screw that the bubble has moved toward. Then tighten the circular level adjustment screw. Return the bubble only one-half the amount of the total error.
- 2** Recenter the circular level bubble with the three leveling screws.
- 3** The bubble should now remain centered as the telescope is revolved around its axis.

If the bubble does not remain centered then the above adjustment should be repeated until the bubble remains centered when the instrument is revolved around its axis.

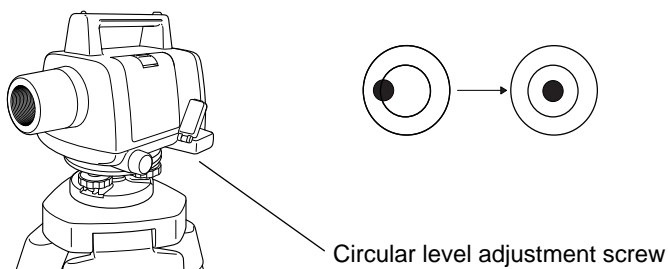

Adjusting Mode

Adjust the instrument by the following steps.

- 1 Set the instrument at the center between staff A and B.
Center the bubble of the circular level with the three leveling screws.

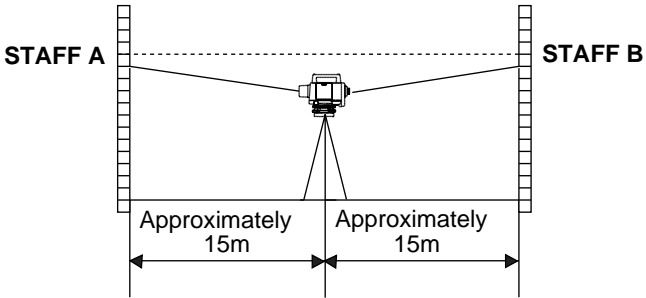

- 2 While pressing the [HDif] key, press power switch to set the indicator adjustment mode.
- 3 Collimate the staff A and push the [Meas] key. (step1)



- 4 Collimate the staff B and push the [Meas] key. (step2)



- 5 Set the instrument at the position that is approximately 3m apart from the staff A. Center the bubble of the circular level again with the three leveling screws.

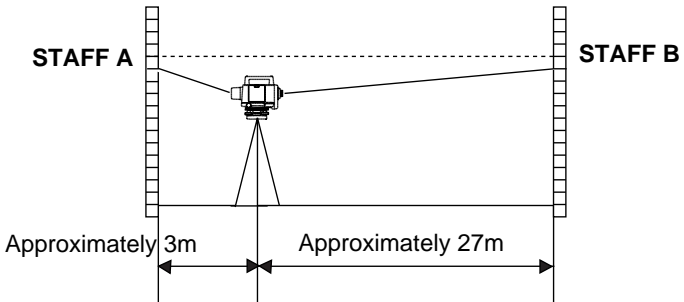

- 6** Collimate the staff A and push the [Meas] key. (step3)

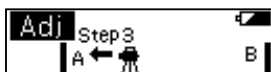

- 7** Collimate the staff B and push the [Meas] key. (step4)

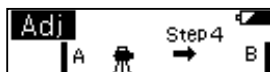

- 8** The complemented value (electrical reading pattern) is displayed.

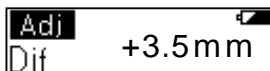

Press the [D/R] key to set displayed electrical adjustment value, then the software indicates the rod value that should be complemented for the reticle adjustment.

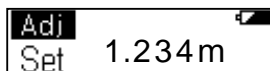

Here the electrical adjustment is completed, however, we recommend to check the optical reading (Reticle adjustment) with the following procedure always when the electrical adjustment is performed.

- 9** Reverse the staff B to be optical reading pattern side. Take the reticle cover off. Adjust the reticle adjustment screws by using the hexagon wrench till the reticle is complemented height. In case that the reticle adjustment is ensured prior to above electrical adjustment, you can skip this step **9** and turn off the instrument.

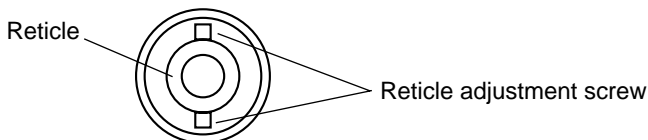

- 10** Turn off the power supply.

ERROR ABOUT INSTRUMENT

Display	Explanation	Countermeasure
Comp Err	The inclination of the instrument exceeds the capacity of the compensator.	Level the instrument properly.
Dark Err	The level cannot read the rod due to lack of light.	The data will have to be entered manually until lighting has improved.
Light Err	The level cannot read the rod due to an excess of light such as direct sunlight or glare.	Remove the source of the sunlight or glare from the objective lens.
ROM Err	This message is displayed when any abnormality occurs with internal memory.	Turn the power switch off then on again.
CCD Err	Any abnormality occurs within the CPU.	Turn the power switch off then on again.
No Staff	Level is not properly sighted on the staff.	Collimate the staff properly.
Meas Err	<ul style="list-style-type: none"> • The distance between the instrument and the staff is either too far or near. • The staff is obstructed by more than 30 percent. • The cross-hairs are not within the range of the staff. 	<ul style="list-style-type: none"> • The distance between the instrument and the staff should be within the range of 2m to 60m. (Fiberglass staff) • Remove the obstructions. • The staff should be within the range of the cross-hairs.
CPU Err	Any abnormality occurs within the CPU.	Turn the power switch off then on again.
COMM Err	Communication Error	Confirm the setting of communication and try to communicate again.
Coll Err	An invalid value has been collected during the adjustment process.	Start the adjustment procedure from the beginning.
Opr Err	Level is not properly sighted during the adjustment process.	Start the adjustment procedure from the beginning.
Setting Err	Level is not set approximately during the adjustment process.	Set the instrument approximately Start the adjustment procedure from the beginning.
Focus Err	Auto focus doesn't function precisely.	Measure again. But auto focus doesn't function precisely, use manual focus.

If errors still persist after attempting to clear them, contact your local TOPCON dealer.

Optional Accessories

Aluminum Staff SA-5M (5m)

Fiber Staff SG-3M/ 3F/ 3I (3m)

Dome Head Aluminum Extension Leg Tripod QM-1D

Dome Head Aluminum Extension Leg Tripod QM-3D

Aluminum Extension Leg Tripod DM-1

Aluminum Extension Leg Tripod DM-3

SPECIFICATIONS

Telescope

Magnification	: 26X~
Image	: Erect
Objective aperture	: 30mm
Field of view	: 1° 30'
Resolving power	: 4"
Minimum focus	: 0.9m

Compensator

Working range	: ±10'
Setting accuracy	: ± 5"

Height Measurement

Accuracy (Standard deviation for 1km)

Electrical reading	: ±1.8mm (Staff SG-3M/ 3F/ 3I)
	: ±2mm (Staff SA-5M+Circular level)
Optical reading	: ±2.5mm

Least count	: 0.1mm
Measuring range	: 2m ~ 60m

Distance Measurement

Minimum reading	: 1cm
Accuracy	: ±(0.1%xDm) (D>10m)
	: ±10mm(D≤10m)(Staff SG-3M/ 3F/ 3I)
	: ±(0.15%xDm) (D>10m)
	: ±15mm
	: (D≤10m) (Staff SA-5M+Circular level)
Measuring range	: 2m ~ 60m

Measuring Time

(daytime) (+20 °C / +68°F)	: Approximately 2sec.(ManualFocus)
	: Approximately 4sec.(Auto Focus)

Circular level sensitivity

: 10'/ 2mm

Others

Display	: 128x32 Dot matrix LCD
Horizontal Circle	: 360°or 400gon
Power Supply	: 4 AA Dry battery
Operating Time (+20°C / +68°F)	: 16 hours (Manual Focus)
	: 10 hours (Auto Focus)
	(Alkaline manganese dry battery)
Ambient Temperature Range	: -20°C~+50 °C (-4°F to +122°F)
Water protection	: Water proof(IPX 4)
Dimensions(D/W/H)	: 196x168x232mm
	(7.7X6.6X9.1 inch)
Weight	: 2.4kg (5.3lbs)



TOPCON CORPORATION

75-1 Hasunuma-cho, Itabashi-ku, Tokyo, 174-8580 Japan Phone: 3-3558-2520 Fax: 3-3960-4214

TOPCON AMERICA CORPORATION

CORPORATE OFFICE
37 West Century Road, Paramus, New Jersey 07652, U.S.A.
Phone: 201-261-9450 Fax: 201-387-2710 www.Topcon.com
TOPCON CALIFORNIA
3380 Industrial BLVD, Suite 105, West Sacramento, CA 95691, U.S.A.
Phone: 916-374-8575 Fax: 916-374-8329
TOPCON MIDWEST
891 Busse Road, Elk Grove Village, IL 60007, U.S.A.
Phone: 847-734-1700 Fax: 847-734-1712
TOPCON DENVER
109 Inverness Dr, E Uniti Englewood, CO 80112, U.S.A.
Phone: 303-706-0920 Fax: 303-706-0921

TOPCON LASER SYSTEMS, INC.

5758 West Las Positas Blvd., Pleasanton, CA 94588, U.S.A.
Phone: 925-460-1300 Fax: 925-460-1315 www.topconlaser.com

TOPCON EUROPE B.V.

Esse Baan 11, 2908 LJ Capelle a/d IJssel, The Netherlands.
Phone: 010-4585077 Fax: 010-4585045 www.topconeurope.com

TOPCON BELGIUM

Preenakker 8, 1785 Merchtem, Belgium
Phone: 052-37.45.48 Fax: 052-37.45.79

TOPCON DEUTSCHLAND G.m.b.H.

Halskestr. 7, 47877 Willich, Germany.
Phone: 02154-9290 Fax: 02154-929-111 Telex: 8531981 TOPC D

TOPCON S.A.R.L.

104/106, Rue Rivay 92300, Levallois-Perret, France.
Phone: 01-4106 9494 (MEDICAL) 1-4106 9490 (TOPOGRAPHIE)
Fax: 01-47390251

TOPCON ESPAÑA S.A.

HEAD OFFICE
Frederic Mompou 5, 08960, Sant Just Desvern Barcelona, Spain.
Phone: 93-473-4057 Fax: 93-473-3932
MADRID OFFICE
Avenida Ciudad de Barcelona 81, 1 Planta 28007, Madrid, Spain.
Phone: 91-552-4160 Fax: 91-552-4161

TOPCON SCANDINAVIA A. B.

Industrivägen 4 P. O. Box 2140 43302 Sävedalen Sweden.
Phone: 031-261250 Fax: 031-268607 Telex: 21414

TOPCON (GREAT BRITAIN) LTD.

HEAD OFFICE
Coach House, London Road, Hurst Green, EastSussex TN19 7QP U.K.
Phone: 01580-860801 Fax: 01580-860802

TOPCON SINGAPORE PTE. LTD.

Alexandra Distripark Block 4, #05-15, Pasir Panjang Road, Singapore 118491
Phone: 2780222 Fax: 2733540 E-mail: topconts@singnet.com.sg

TOPCON AUSTRALIA PTY. LTD.

408 Victoria Road, Gladesville, NSW 2111, Australia
Phone: 02-9817-4666 Fax: 02-9817-4654

TOPCON INSTRUMENTS (THAILAND) CO., LTD.

77/162 Sinn Sathorn Tower, 37th Fl.,
Krungthongburi Rd., Klonglonsai, Klongsarn, Bangkok 10600 Thailand.
Phone: 662-440-1152-7 Fax: 662-440-1158

TOPCON INSTRUMENTS (MALAYSIA) SDN. BHD.

Lot 226 Jalan Negara 2, Pusat Bandar Taman Melawati,
Taman Melawati, 53100, Kuala Lumpur, Malaysia.
Phone: 03-4079801 Fax: 03-4079796

TOPCON KOREA CORPORATION

Hyobong Bldg., 1-1306, Seocho-Dong, Seocho-Gu, Seoul, Korea.
Phone: 02-3482-9231 Fax: 02-3481-1928

TOPCON OPTICAL (H.K.) LIMITED

2/F, Meeco Industrial Bldg., No. 53-55 Au Pui Wan Street, Fo Tan Road,
Shatin, N.T., Hong Kong
Phone: 2690-1328 Fax: 2690-2221 E-mail: sales@topcon.com.hk

TOPCON CORPORATION BEIJING OFFICE

Room No. 962 Poly Plaza Building, 14 Dongzhimen Nandajie,
Dongcheng District, Beijing, 100027, China
Phone: 10-6501-4191-2 Fax: 10-6501-4190

TOPCON CORPORATION BEIRUT OFFICE

P. O. BOX 70-1002 Antelias, BEIRUT-LEBANON.
Phone: 961-4-523525/961-4-523526 Fax: 961-4-521119

TOPCON CORPORATION DUBAI OFFICE

Office No. 102, Khalaf Rashid Al Nayli Bldg., 245 Abu Hail Road, Deira, Dubai, UAE
Phone: 971-4-696511 Fax: 971-4-695272