

Owner's Guide

GENERAL PURPOSE FREEZERS Model: LABH-7-FM, LABH-14-FM, LABH-17-FM, LABH-20-FM, LABH-20-FM3, LABH-30-FM, LABH-30-FM3, LABH-30-FA

OWNER'S INSTRUCTIONS

This manual describes how to operate and care for your appliance to get the best, most efficient, performance.

READ THIS BOOK!

Note to Customer: This merchandise was carefully packed and thoroughly inspected before leaving our plant. Responsibility for its safe delivery was assumed by the carrier upon acceptance of the shipment. As directed on the side of your packing carton, claims for loss or damage sustained in transit must be made on the carrier as follows:

- A.) **Visible Loss, Damage, Shortage External Evidence of Loss or Damage:** This type of damage **must** be noted on the freight bill and acknowledged by the carrier's agent (driver) at time of delivery. Make sure you get a signed copy. Send a written request for an inspection to the carrier.
- B.) **Concealed Damage:** This type of damage may not be discovered until the unit is being unpacked. When concealed damage is discovered, stop unpacking immediately and contact the carrier immediately to report the claim and request an inspection. This should be done as soon as possible and, in any case, must be done within 15 days of receiving the merchandise. If at all possible, do not move the item and save all packaging material for carrier's inspection.
- C.) **FAILURE TO FOLLOW THESE INSTRUCTIONS MAY RESULT IN THE CARRIER REFUSING TO HONOR YOUR COMPANY'S CLAIM. UNDER NO CIRCUMSTANCES SHOULD THE MERCHANDISE BE RETURNED TO THE MANUFACTURER. NO RETURNS WILL BE ACCEPTED WITHOUT PRIOR AUTHORIZATION.**

Horizon Scientific
125 Varnfield Drive
Summerville, SC 29483
Phone: 800-648-4041
Fax: 843-821-8051

Warranty:
Two-Year Parts and Labor
5 Years Compressor Parts

Revision Date
03/06/2012

Table of Contents

RECEIVING	3
INSTALLATION	4
FREEZER OPERATION	8
QUICK TROUBLE-SHOOTING GUIDE.....	9
MAINTENANCE AND CLEANING	11
PRODUCT WARRANTY	13

BEFORE CALLING THE MANUFACTURER’S TECHNICAL SUPPORT DEPARTMENT, please have the unit’s model and serial number ready as well as the problem description. The model and serial number is located on the serial tag which can be found on the interior left upper wall of the unit.

For convenience, you may want to record the following information here for easy access in the future.

Model number: _____

Serial number: _____

Date of delivery: _____

Receiving

Your unit was built, packaged, and inspected with extreme care. We shipped it to you using carriers we trust with a proven track record of careful handling, good customer service, and on time delivery. Unfortunately, regardless of all of these efforts sometimes accidents happen and occasionally those accidents result in shipping damage. When the carrier picked up the merchandise from us, they assumed responsibility for its condition en route to you. Thus, any claims for shipping damage must be filed with the carrier. Like anybody else, carriers don't like to pay out on insurance claims, so their claims procedures and requirements are very restrictive. You should consult the carrier's website for their specific claims procedures. You should also know that time is of the essence.

There are two general types of shipping damage. The first is **visible damage**. This type of damage includes visible loss, damage, shortage or any external evidence of loss or damage that is visible at time of delivery. **This type of damage must be noted in detail on your delivery receipt. Make sure the driver signs and dates the delivery receipt, acknowledging the damage.** This has to happen at the time of delivery or it won't happen at all. Keep a copy for your records and send another to the carrier's damage claims department along with a formal request for an inspection report. Follow up with a phone call. Their contact information can be found on the carrier's web site.

The second type of shipping damage is **concealed damage**. This type of damage will probably not be apparent at time of delivery and may not be discovered until unpacking and inspecting the unit. Remember, time is of the essence here. You should unpack and inspect the unit as soon as possible. Each day that passes reduces the likelihood that the carrier will pay the claim. **As soon as the concealed damage is discovered, stop unpacking and retain all packing materials. Contact the carrier by phone to report the claim.** Note the date and time and person you spoke with. Get a claim number. Follow up with a written letter referencing the claim number and including a formal request for an inspection. Again, consult the carrier's website for specific claim instructions and follow them precisely.

AS STATED ABOVE, THE CARRIER IS YOUR SOLE SOURCE FOR SATISFACTION OF A DAMAGE CLAIM. UNDER NO CIRCUMSTANCES SHOULD THE MERCHANDISE BE RETURNED TO THE MANUFACTURER. NO RETURNS WILL BE ACCEPTED WITHOUT PRIOR AUTHORIZATION.

Installation

UNCRATING – Move your refrigerator as close to the final location as possible before unpacking. Remove the wooden planks or skid. The location should be as close as possible to the power outlet. This unit requires a **minimum of 4 inches of air flow space in back and 3 inches on the sides and top.** Do not store material on the top of this unit.

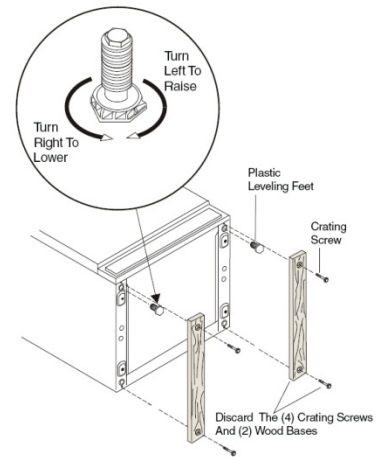

PLEASE NOTE! Your refrigerator or freezer is designed for **INDOOR USE** and should be operated in an air conditioned space with temperature between 65°F to 85°F.

LEVELING – You can level your unit with the screw-type adjustable leveling legs on the front corners of the unit. Turn counterclockwise to raise the corner; turn clockwise to lower it. Leveling legs are required in front only. The unit may have a slight tilt from front to back after legs are installed. This is acceptable and is recommended on this unit.

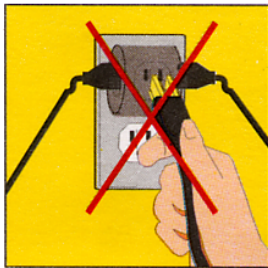

Never plug in more than one unit per electrical outlet.

POWER SOURCE – The supply circuit to this cabinet must conform to all National and Local Electrical Codes. Consult the cabinet Serial-Data plate for voltage, cycle, phase, and amp requirements before making connection. **VOLTAGE SHOULD NOT VARY MORE THAN 5% FROM SERIAL PLATE RATINGS.** A separate circuit is recommended to prevent possible

loss of product due to over-loading or failure of other equipment on the same circuit.

PROTECT THE CIRCUIT WITH A 20 AMP DELAY-TYPE FUSE OR CIRCUIT BREAKER. Do not use an extension cord. Be sure your unit is properly grounded. Use the 3-prong plug provided into a 3-prong grounded outlet. (Only this method complies with national electrical codes, local codes and ordinances.) Unless the above grounding method is followed, you are not protected against severe or lethal shock in the event of a short circuit of an electrical component or wiring of the unit.

STARTING – There are no compressor shipping bolts to loosen or valves to open. All that is necessary after the unit has been properly leveled is to plug the service cord into an electrical outlet. When starting this new appliance, allow the cabinet to operate a minimum of **eight hours** or until it has started cycling normally before placing product in the cabinet. The motor compressor may

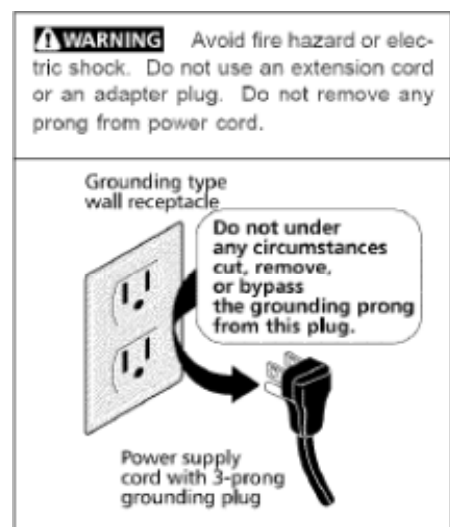

start and stop several times when the unit is first started or after defrosting, especially if the weather is very hot. This is only normal functioning of the motor overload protector. The motor compressor will cycle normally as soon as the excess heat has been removed.

Adjustable Shelf Installation (not applicable to all models)

Hook shelf clips onto pilaster strips (see Illustration). Position all four shelf clips equal in distance from the floor for flat shelves. Wire shelves are oriented so that cross support bars are facing down.

Place shelves on shelf clips making sure all corners are seated properly.

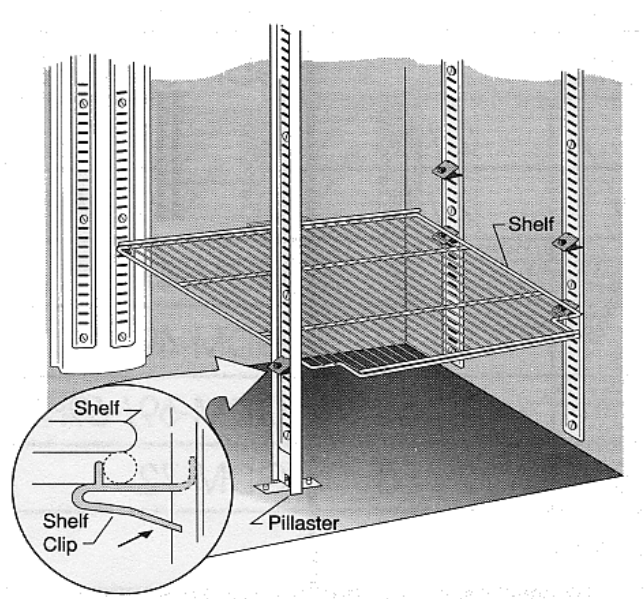

Temperature control

NOTE: The controls are preset at the factory to provide the desired air and product temperatures inside of the units and require no further adjustment. Please contact the manufacturer's Technical Support Department before making any adjustments to determine if adjustment is necessary and, if so, to make sure it is performed properly.

Manual Thermostat (Excludes LABH-30-FM3)

This unit has a manual thermostat located inside of the compartment. This thermostat controls the compressor. Turning the thermostat towards the higher numbers will make the unit colder. Lower numbers make it warmer. Turning the thermostat to the off or 0 position will turn the unit off.

Digital Microprocessor Temperature Controller (For Model: LABH-30-FM3 and LABH-20-FM3 ONLY)

The digital microprocessor temperature controller is designed to provide on/off control of refrigerators or freezers. The controller also provides a constant readout of the air temperature inside of the unit. A touch keypad allows the user to easily select the display units, set point, differential set point, and heating or cooling mode.

Please Note: The digital temperature controller has been factory set and tested to allow your unit to operate at its designed temperature cycle. Adjusting the settings on the controller will alter these factory settings. Please allow the unit to operate at least 8 hours after the initial startup before making any temperature adjustment. WE STRONGLY RECOMMEND YOU CONTACT THE MANUFACTURER'S TECHNICAL SERVICE DEPARTMENT BEFORE MAKING ANY ADJUSTMENTS TO THIS CONTROLLER.

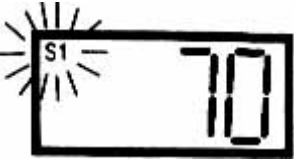
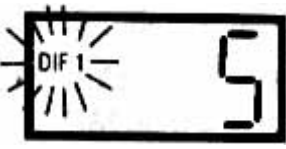
Steps	Procedure	Annunciator	Description	Display
Step 1	To start programming, press the SET key once to access the Fahrenheit/Celsius mode. The display shows the current status, F for degrees Fahrenheit or C for degrees Celsius. Press either up or down arrow to toggle between the F or C .	F or C	Fahrenheit or Celsius Scale	
Step 2	Press SET key again to access the setpoint mode. The LCD will display the current setpoint and S1 will be blinking to indicate that the control is in the setpoint mode. Press the up and down keys to adjust the set point to the desired setting.	S1 (blinking)	Setpoint Temperature	
Step 3	Press SET key again to access the differential mode. The LCD will display the current differential and DIF1 will be blinking to indicate that the control is in the differential mode. . Press the up and down keys to adjust the differential to the desired setting.	DIF 1 (blinking)	Differential Temperature	

Step 4	Press SET key again to access the cooling or heating mode. The LCD will display the current mode, either C1 for cooling or H1 for heating. Then press the up or down key to toggle between the C1 or H1 designation. Press the SET key once more and programming is complete.	C1 / H1	Cooling or Heating mode	
--------	---	----------------	-------------------------	---

Troubleshooting error messages for Microprocessor control

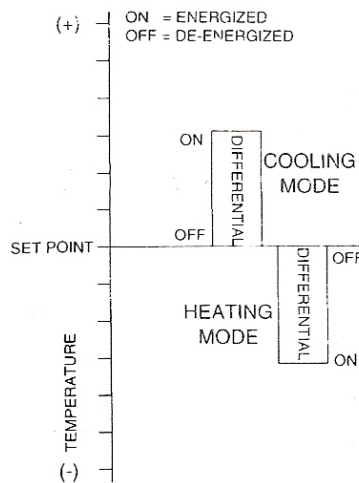

Figure 1: Setpoint and Differential Settings. Diagram indicates relay on and off points in either the heating or cooling modes.

Display	Messages	To correct
E1	Appears when either the up or down key is pressed when not in the program mode	If the E1 message appears even when no keys are being pressed, replace control.
E2	Appears if the control settings are not properly stored in memory.	Check all settings and correct if necessary.
EP	Appears when the probe is open, shorted or sensing a temperature that is out of range.	Check to see if the sensed temperature is out of range. If not, check for probe damage by comparing it to a known ambient temperature between -30°F and 220°F. Replace the probe if necessary.
EE	Appears if the EPROM data has been corrupted.	This condition cannot be field repaired. Replace the control.
CL	Appears if calibration mode has been entered.	Remove power to the control for at least five seconds. Reapply power. If the CL message still appears, replace the control.

Freezer Operation

After the unit is properly installed and power is applied, it will take some time before the system is cooled down to temperature and cycling normally. You should wait 8 hours on the first startup before beginning to add product to the unit. This ensures that the unit is installed and operating properly before being put into service. On subsequent startups (after cleanings, for example), this wait time can be reduced to about 3 hours. After this wait time, the unit should be cycling in the design temperature range. The units are calibrated before leaving the factory, so no adjustment should be necessary.

Loading the units will again cause temperature to rise as the warmer product is introduced into the compartment. If a large amount of product is to be introduced, it is a good idea to do it in stages, allowing several hours between stages to allow temperature to stabilize again before introducing additional warm product. This will minimize the temperature transient while loading. Other tips for successful loading include:

- Leave about 2-3 inches of free space along the back and sides of the unit to allow for proper air flow and, therefore, more even cooling of the product.
- When loading the top shelf, avoid blocking the evaporator fan(s) (if installed). There should be at least 4 inches of clearance below the fan(s) to allow proper air flow.
- Do not overload the unit. A full load is about 70 to 75% full. Additionally, the load should be distributed evenly from top to bottom and side to side for best results.
- Minimize the time the door is open. On top of letting the cold air out, you are also letting warm, moist air in which can result in more condensation and/or frost in the unit.

The auto-defrost models will periodically (usually 2 to 4 times a day) go into a defrost cycle to remove frost build-up. During this cycle, the compressor is turned off and defrost heaters are turned on in the evaporator section. This will cause a temperature transient which will be seen in air temperature inside the unit but should not significantly affect product temperatures.

Remember that the units are calibrated to the design temperature range before leaving the factory. We also do extensive testing to ensure that these temperatures will result in product temperatures in the desired band. There should be no need to adjust the temperature control on these units, but if it is necessary, they can be adjusted using the manual thermostat on the back of the unit.

It is STRONGLY RECOMMENDED that you contact the manufacturer's Technical Support Department prior to performing any temperature adjustments to ensure the adjustment is necessary and, if so, it is performed correctly.

Quick Troubleshooting Guide

Check these items before calling for service

PROBLEM:	POSSIBLE CAUSE / SOLUTIONS:
Unit does not run	<ul style="list-style-type: none"> • Electrical circuit is not 110-120V 60Hz. • The power cord is not plugged in. • No power at electrical outlet. Check to make sure breaker is not tripped or fuse is not blown. Additionally, make sure unit is not plugged into a Ground Fault Circuit Interrupter (GFCI) type of outlet.
Unit does not maintain at the proper temperature	<ul style="list-style-type: none"> • Check the room temperature. We recommend the refrigerator or freezer should be placed in the air conditioned room between 65°F to 85°F. If the room temp is too warm, the refrigerator or freezer may not be able to maintain the interior temp at proper range. • Door is not closed properly. • Amount of stored product is overloaded. • Product replacements are pushed against rear wall or interrupted the proper refrigerator air circulation. For the proper air circulation, place the products evenly on each shelf. Do not push against the refrigerator's rear or side walls. • Evaporator is blocked by frost or ice. Remove the products, unplug the refrigerator or freezer power, and allow the unit to defrost. If the problem still exists, call for service. • 3rd party thermometer is placed incorrectly. For proper temperature monitoring, the thermometer should be placed in the middle of refrigerator.
Appliance runs too long	<ul style="list-style-type: none"> • Prolong door openings. • Control set too cold. • Room temperature is high which will make the unit work harder to keep cool.
Temperature of external wall surface is warm	<ul style="list-style-type: none"> • The exterior walls can be as much as 30 degrees warmer than room temperature due to the embedded condenser coils. This is normal when the unit is operating.

PROBLEM:	POSSIBLE CAUSE / SOLUTIONS:
Compressor noises	<ul style="list-style-type: none"> • Compressor may be overheated. Please check the room temp and ensure the range is within 65°F to 85°F. If the problem still exists, call for service.
Moisture collects inside	<ul style="list-style-type: none"> • Door gasket is not sealing properly. Check for debris, cracks, and items passing through door at the gasket. • The refrigerator or freezer is facing a doorway or is underneath of air conditioning vent. Relocate the unit or redirect air vent. • Too many door openings. Minimize time door is open. • Hot, humid weather increases condensation. • Make sure there is a water trap (U-shaped loop) in the drain tube near the compressor. This will “trap” a small amount of water in the loop and prevent air from entering the chamber through the tube.
Moisture collects on outside surface	<ul style="list-style-type: none"> • Hot, humid weather increases condensation. • As humidity decreases, moisture will disappear.
Odor inside the unit	<ul style="list-style-type: none"> • Interior needs to be cleaned. See section on maintenance and cleaning in this manual. • Make sure product containers are tightly sealed to prevent leakage
Door will not close	<ul style="list-style-type: none"> • The unit is not level. Refer to the Leveling section at the beginning of this manual • Check for dirt and debris or items passing through the door seal.

Moisture during the Summer months

The amount of moisture, condensation, or high humidity related issues increase during the summer and, in most cases, will self-resolve when the weather cools down. Please note a refrigeration system will NOT generate moisture or water but simply condenses the moisture that is already in the chamber. Keeping the unit in an air conditioned, low humidity space will resolve many issues.

Other things you should check:

1. Location of the refrigerator (See Quick Troubleshooting Guide above)
2. Door sealing and frequency of door opening event (See Quick Troubleshooting Guide above)
3. Make sure there is a water trap (U-shaped loop) in the drain tube near the end. This will “trap” a small amount of water in the loop and prevent air from entering the chamber through the tube.

BEFORE CALLING THE MANUFACTURER’S TECHNICAL SUPPORT DEPARTMENT, please have the unit’s model and serial number ready as well as the problem description. The model and serial number is located on the serial tag which can be found on the interior left upper wall of the unit.

Maintenance and Cleaning

Manual-Defrost Freezers should be defrosted whenever $\frac{1}{4}$ to $\frac{1}{2}$ inch of frost has accumulated. Use the procedures in the defrosting section starting at the bottom of this page for best results.

Auto-Defrost Freezers require little maintenance but should be cleaned periodically to keep them running efficiently. Use the cleaning agents and suggestions in this table for best results.

CLEANING

PART	CLEANING AGENTS	TIPS AND PRECAUTIONS
Interior and Door Liners	Soap and water Baking soda and water	Use 2 tablespoons of baking soda in 1 quart of warm water Be sure to wring excess water out of sponge or cloth before cleaning around controls, light bulb or any electrical parts.
Door Gaskets	Soap and water	Wipe gaskets and their seating surfaces with a clean soft cloth
Shelves	Soap and water	Do not wash removable shelves in dishwasher
Exterior and Handles	Soap and water Non Abrasive Glass Cleaner	Do not use commercial household cleaners, ammonia, or alcohol to clean handles Use a soft cloth to clean smooth handles Do not use a dry cloth to clean smooth handles

Defrosting (MANUAL DEFROST FREEZERS ONLY, EXCLUDES LABH-30FA)

It is important to defrost and clean the freezer when $\frac{1}{4}$ to $\frac{1}{2}$ inch of frost has accumulated. Frost may tend to accumulate faster on upper part of the freezer due to warm, moist air entering the freezer when the door is opened. Between defrost evolutions; you can minimize frost build-up by using a plastic scraper to remove frost. Scrape with a pulling motion. Never use a metal instrument to remove frost. Never use a damp cloth or wet hands as they will stick to the inside surfaces when cold. When defrosting becomes necessary, disconnect freezer from power source by unplugging to avoid electrical hazard. **DO NOT ADJUST THE THERMOSTAT.** Remove the product and leave the door open while defrosting the freezer.

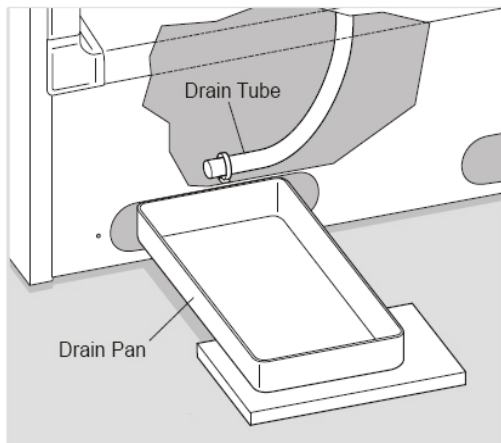

Remove the drain plug on the inside floor of the freezer by pulling straight out. To access the external drain tube on models with a base panel, first remove the two screws from the base panel. Locate the drain tube near the left center under the freezer. Place a shallow pan under the drain tube. Defrost water will drain out. Check the pan occasionally to ensure it does not overflow. A ½ inch garden hose adaptor (available at most hardware stores) can be used to drain the freezer directly into a floor drain. Replace the drain plug when defrosting is complete so warm air does not enter the freezer through the hole.

Defrosting tips – If the frost is soft, remove it with a plastic scraper. If the frost is glazed and hard, fill deep pans with hot water and place them inside on the freezer bottom. Close the freezer door. Frost should soften in about 15 minutes. Repeat this procedure as necessary until all frost is removed.

After defrosting - replace the drain plugs (if applicable) and remove any towels, tools, or pans from the interior of the freezer. Clean the interior and exterior of the unit using the cleaning suggestions on the previous page. Plug the unit back in and restore it to service per the operation section of this manual.

Product Warranty

HORIZON SCIENTIFIC, INC. PRODUCT WARRANTY

Horizon Scientific, Inc. warrants to the original purchaser every new Horizon Scientific, Inc. refrigerated unit, the cabinet and all parts thereof, to be free from defects in material or workmanship, when such unit is installed, used, and maintained in accordance with provided instructions, for a period of two (2) years. The warranty period starts two weeks from the date of shipment from Horizon Scientific, Inc. This two week period allows ample shipping time so that the warranty will go into effect at approximately the same time your equipment is delivered. Unless subject to prior written agreement with Horizon Scientific, Inc., this warranty does not allow for any warranty start deferment greater than two weeks from date of shipment due to a delayed installation and/or start-up. By purchasing any product from Horizon Scientific, Inc., you and any entity for which you are purchasing acknowledge and agree to each and every provision contained herein, and all other Notices and Terms provided to Purchaser by Horizon Scientific, Inc., which are hereby incorporated.

Under this warranty, Horizon Scientific, Inc., through its authorized service organizations, will repair, or at its option, replace any part found to contain a manufacturing defect in material or workmanship without charge to the owner for parts, service labor or any shipping or cartage costs. Replacement or repaired parts will be warranted for only the unexpired portion of the original warranty.

ADDITIONAL THREE YEAR COMPRESSOR WARRANTY

In addition to the two (2) year warranty stated above, Horizon Scientific, Inc. warrants its hermetically and semi-hermetically sealed compressors to be free from defects in both material and workmanship under normal use and service for a period of three (3) additional years from the end of the initial two (2) year warranty period, but not to exceed five (5) years after shipment from Horizon Scientific, Inc.

Compressors determined by Horizon Scientific, Inc. to have been defective within this extended time period will, at Horizon Scientific, Inc.'s option, be either repaired or replaced with a compressor or compressor parts of similar design and capacity.

The three (3) year extended compressor warranty applies only to hermetically and semi-hermetically sealed parts of the compressor and does not apply to any other parts or components, including, but not limited to, cabinet, paint finish, temperature control, refrigerant, metering device, driers, motor starting equipment, fan assembly or any other electrical components.

Horizon Scientific, Inc.'s sole obligation under this warranty is limited to either repair or replacement of parts, subject to the additional limitations below. This warranty neither assumes nor authorizes any person to assume obligations other than expressly covered by this warranty.

NO CONSEQUENTIAL DAMAGES. Horizon Scientific, Inc. is not responsible for economic loss; profit loss; or special, indirect or consequential damages, including without limitation, losses or damages arising from contents spoilage claims whether or not on account of refrigeration failure, electrical failure, power failure, or compressor failure. HORIZON SCIENTIFIC, INC.'S MAXIMUM CUMULATIVE LIABILITY RELATIVE TO ALL CLAIMS AND LIABILITIES, INCLUDING OBLIGATIONS UNDER ANY INDEMNITY, WHETHER OR NOT INSURED, SHALL NOT EXCEED THE COST OF THE PRODUCT(S) GIVING RISE TO THE CLAIM OR LIABILITY.

WARRANTY IS NOT TRANSFERABLE. This warranty is not assignable and applies only in favor of the original purchaser/user to whom delivered. Any such assignment or transfer shall void the warranties herein made and shall void all warranties, express or implied, including any warranty of merchantability or fitness for a particular purpose.

NO IMPLIED WARRANTY OF MERCHANTABILITY OR FITNESS FOR A PARTICULAR PURPOSE. There are no other warranties, express, implied, or statutory, except the two (2) year warranty and the additional three (3) year compressor warranty as described above. These warranties are exclusive and in lieu of all other warranties, including implied warranty and merchantability or fitness for a particular purpose. There are no warranties which extend beyond the description on the face hereof, whether based on contract, warranty, tort (including negligence), strict liability, indemnity, or any other legal theory, and whether arising out of warranties, representations, instructions, installations, or non-conformities from any cause. Purchaser further acknowledges that the purchase price of the Product reflects these warranty terms and remedies.

ALTERATION, NEGLIGENCE, ABUSE, MISUSE, ACCIDENT, DAMAGE DURING TRANSIT OR INSTALLATION, FIRE, FLOOD OR OTHER EXTERNAL CAUSES.

Horizon Scientific, Inc. is not responsible for the repair or replacement of any parts that Horizon Scientific, Inc. determines have been subjected after the date of manufacture to alteration, neglect, abuse, misuse, accident, damage during transit or installation, fire, flood or other external causes. It does not apply to defects resulting from failure to properly install, operate or maintain the product in accordance with the printed instructions provided, or damage caused by the storage of any corrosive material that comes in contact with the interior or exterior portions of the cabinet, or the use of spark producing equipment or containers (such as galvanized or carbonized steel containers) that come in contact with any interior portion of the cabinet.

OUTSIDE U.S./CANADA. This warranty does not apply to, and Horizon Scientific, Inc. is not responsible for, any warranty claims made on products sold or used outside the United States and Canada.

CHOICE OF LAW/VENUE. The laws of the State of South Carolina shall govern the validity, interpretation and enforcement of this warranty, regardless of conflicts of law principles. Purchaser agrees that proper venue for any action to enforce the terms of this warranty shall be the Dorchester County District Courts, South Carolina. Purchaser submits the jurisdiction of such courts over the Purchaser and the subject matter of any such action. Any action for breach of these warranty provisions must be commenced within one (1) year after that cause of action has accrued.

WARRANTY CLAIMS. To obtain prompt warranty service, simply contact the manufacturer at 800-648-4041. Horizon Scientific, Inc.'s shipping records showing date of shipment shall be conclusive in establishing the warranty period. All claims should include: model number of the refrigerator, the serial number of the cabinet, proof of purchase, date of installation, and all pertinent information supporting the existence of the alleged defect. Any repairs must be authorized by Horizon in order for the warranty to be honored.