**User's
Manual**

**Model SPRG
(Style E)
Programmer**

YEW SERIES 80

IM 1B4W1-02E

Notices

■ Regarding This User's Manual

- (1) This manual should be passed on to the end user. Keep at least one extra copy of the manual in a safe place.
- (2) Read this manual carefully and fully understand how to operate this product before you start operation.
- (3) This manual is intended to describe the functions of this product. Yokogawa Electric Corporation (hereinafter simply referred to as Yokogawa) does not guarantee that the functions will suit a particular purpose of the user.
- (4) Under absolutely no circumstances may the contents of this manual in part or in whole be transcribed or copied without permission.
- (5) The contents of this manual are subject to change without prior notice.
- (6) Every effort has been made to ensure accuracy in the preparation of this manual. Should any error or omissions come to your attention however, please contact your nearest Yokogawa representative or our sales office.

■ Regarding Protection, Safety, and Prohibition against Unauthorized Modification

- (1) In order to protect the product and the system controlled by it against damage and ensure its safe use, make certain that all of the instructions and precautions relating to safety contained in this manual are strictly adhered to. Yokogawa does not guarantee safety if products are not handled according to these instructions.
- (2) Be sure to use the spare parts approved by Yokogawa when replacing parts or consumables.
- (3) Modification of the product is strictly prohibited.
- (4) Reverse engineering such as the disassembly or decompilation of software is strictly prohibited.
- (5) No portion of the software supplied by Yokogawa may be transferred, exchanged, leased or sublet for use by any third party without the prior permission of Yokogawa.

■ Force Majeure

- (1) Yokogawa does not make any warranties regarding the product except those mentioned in the WARRANTY that is provided separately.
- (2) Yokogawa assumes no liability to any party for any loss or damage, direct or indirect, caused by the user or any unpredictable defect of the product.

CONTENTS

<i>Section</i>	<i>Title</i>	<i>Page</i>	<i>Section</i>	<i>Title</i>	<i>Page</i>
1.	INTRODUCTION	1-1	5.	OPERATION	5-1
1-1.	Model and Suffix Codes	1-1	5-1.	Front Panel Features	5-1
1-2.	Scope of This Manual and Associated Manuals	1-1	5-2.	Toggle Switches	5-1
2.	GENERAL	2-1	5-2-1.	Mode (TEST RUN/PROGRAM) Switches	5-1
2-1.	Standard Specifications	2-2	5-2-2.	Power Switch (POWER ON/OFF)	5-2
2-2.	Model and Suffix Codes	2-2	5-3.	Programmer Control Keys	5-2
2-3.	Options	2-2	5-3-1.	F (Shift key)	5-2
2-4.	Accessories	2-2	5-3-2.	G (Shift key)	5-2
3.	INSTALLATION	3-1	5-3-3.	MPR (Main program key)	5-2
3-1.	Installation	3-1	5-3-4.	SBP (Subprogram key)	5-2
3-2.	Cable Connection	3-1	5-3-5.	SPR (Simulation program key)	5-2
3-2-1.	Cable Connection Procedures	3-1	5-3-6.	INZ (Program-erasing key)	5-2
3-2-2.	Cable Disconnection Procedures	3-1	5-3-7.	RS (Reset key)	5-2
3-2-3.	Connecting SPRG to SLPC, SLMC or SCMS	3-2	5-3-8.	WR (Program-write key)	5-2
3-2-4.	Connecting SPRG to SPLR Programmable Computing Unit	3-2	5-3-9.	RD (Program-read key)	5-2
3-2-5.	Connecting SPRG to IPL Computing Station	3-2	5-3-10.	XFR (Program transfer key)	5-2
3-2-6.	Connecting SPRG to IPL Computing Unit	3-3	5-3-11.	RUN (Test run execution key)	5-2
3-2-7.	Connecting SPRG to Printer	3-3	5-3-12.	CAN (Clear - partial erasure - key)	5-3
3-2-8.	Turning ON the Power	3-3	5-3-13.	▲ (Forward-step key)	5-3
4.	PRINCIPLES OF OPERATION	4-1	5-3-14.	▼ (Back-step key)	5-3
4-1.	Principles of Operation	4-1	5-3-15.	ENT (Entry key)	5-3
4-2.	Simple Program, Example-1	4-2	5-3-16.	DEL (Delete program step key)	5-3
4-2-1.	Preparation	4-3	5-3-17.	INIP (Parameter erasing key)	5-3
4-2-2.	Programming	4-3	5-4.	Numeric Keys	5-3
4-2-3.	Test Run	4-3	5-5.	Register Keys	5-3
4-2-4.	Specifying Display Table	4-4	5-6.	DIO Designation Key	5-3
4-3.	Simple Program, Example-2	4-5	5-7.	CNT Designation Key	5-4
4-3-1.	Preparation	4-5	5-8.	Computational and Control Program Keys	5-4
4-3-2.	Programming	4-5	5-9.	ID Number Setting Key	5-7
4-3-3.	Test Run	4-6	5-10.	Printer Control Keys	5-7
4-3-4.	Changing Constants during Test Run	4-6	5-10-1.	LIST (Program list key)	5-7
4-3-5.	Specifying Display Table	4-6	5-10-2.	PMT (Display table, constant and parameter keys)	5-7
			5-10-3.	REG (Register key)	5-7

<u>Section</u>	<u>Title</u>	<u>Page</u>	<u>Section</u>	<u>Title</u>	<u>Page</u>
5-11.	Preparation for Operation	5-7	6.	MAINTENANCE	6-1
5-11-1.	Connecting Power Source Plug	5-7	6-1.	Changing Fuse	6-1
5-11-2.	Connecting Programmable Instrument	5-7	6-2.	Precautions in Handling User ROM	6-1
5-11-3.	Connecting Printer	5-7	7.	TROUBLESHOOTING	7-1
5-12.	Keying in Program	5-7	7-1.	Troubleshooting Flowcharts	7-1
5-12-1.	Preparation	5-7	7-2.	Component Replacement	7-7
5-12-2.	Initializing Programmer	5-8	7-2-1.	Disassembly	7-7
5-12-3.	Keying in Main Program	5-8	7-2-2.	Reassembly	7-7
5-12-4.	Keying in Subprograms	5-8	●	Customer Maintenance	
5-12-5.	Keying in Simulation Program	5-8		Parts List	CMPL 1B4W1-03E
5-12-6.	Keying in DIOs	5-9			
5-12-7.	Keying in Constants	5-9			
5-12-8.	Designating Control Functions	5-9			
5-12-9.	Designating Display Table	5-10			
5-12-10.	Setting ROM ID Number	5-10			
5-13.	Modifying Program	5-10			
5-13-1.	Deleting Incorrect Key Entry	5-10			
5-13-2.	Deleting Program Step	5-11			
5-13-3.	Inserting Program Step	5-11			
5-13-4.	Jump Instruction Target Address Changes Automatically	5-11			
5-14.	Test Run	5-12			
5-14-1.	Test Run	5-12			
5-14-2.	Load Rate of Program	5-12			
5-14-3.	Displaying and Modifying Register Data	5-13			
5-14-4.	Change of Parameters	5-14			
5-15.	Storing a Program in ROM	5-14			
5-15-1.	Storing Program	5-14			
5-16.	Reading or Erasing ROM Program	5-15			
5-16-1.	Reading ROM Contents	5-15			
5-16-2.	Erasing ROM Contents	5-15			
5-17.	Printout	5-15			
5-17-1.	Printing a Program List	5-16			
5-17-2.	Printing Parameters	5-16			
5-17-3.	Printing Data	5-16			

1. INTRODUCTION.

This instrument was thoroughly tested in the factory before shipment. However, you should inspect it for visible damage to confirm that it was not damaged in transit. You should also confirm that you have received all standard accessories.

Read this chapter before commencing to use this instrument. For other information, check the index and other chapters of this manual.

1-1. Model and Suffix Codes.

The model and suffix codes are marked on a name plate (see Figure 1-2-1 for location).

Confirm that you received what you ordered.

If you have any questions about this instrument, please contact either your nearest Yokogawa Sales & Service Office or Yokogawa Electric Corporation, Tokyo, Japan.

1-2. Scope of This Manual and Associated Manuals.

This Instruction Manual covers handling, operating and simple maintenance procedures for the SPRG Programmer.

Using this Programmer with the SLPC Programmable Indicating Controller involves the following three steps: This instruction manual covers only Step 2 below. For Steps 1 and 3, see the related instruction manual.

Step-1: Applications programming.

[Reference Manuals]

- ① "Programmable Instruments Functions and Applications" TI 1B4C2-02E.

Step-2: Storing Application Programs in ROM (Read Only Memory).

This is covered by this instruction manual.

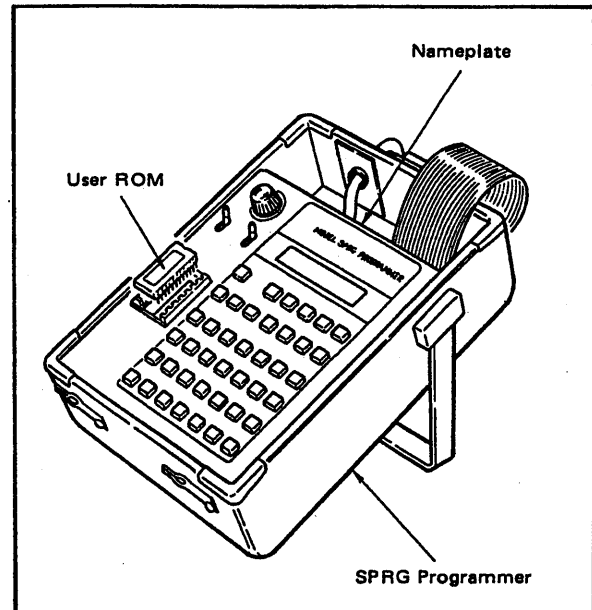

Figure 1-2-1. User ROM and SPRG Programmer.

Step-3: Initiating Operation.

[Reference Manuals]

- ① "SLPC Programmable Indicating Controller" IM 1B4C2-04E.
- ② "SPLR Programmable Computing Unit" IM 1B4L3-01E.
- ③ "SLMC Programmable Indicating Controller with Pulse Width Output" IM 1B4C3-02E.
- ④ "SCMS Programmable Computing Station" IM 1B4D6-01E.

2. GENERAL.

The SPRG Programmer is designed to store control and computational programs – e.g. for the SLPC Programmable Indicating Controller, the SLMC Programmable Indicating Controller with Pulse Width Output, the SCMS Programmable Computing Station, or the SPLR Programmable Computing Unit – in ROM (Read Only Memory).

The Programmer can also store programs for the IPL Computing Station and IPL Computing Unit (Model 5 $\frac{2}{3}$ 47, 5 $\frac{2}{3}$ 55).

When the Programmer is used with the SPCM Pulse Computing Unit, it can set and display SPCM's parameters.

The Programmer has the following functions:

- **Programming functions.**

This programmer is used to prepare SLPC, SLMC, SCMS or SPLR computational/control programs – together with parameters, constants and display tables – and it stores them in its RAM memory.

- **Test run functions.**

Computational expressions for the SLPC, SLMC or SCMS allow you to create a simulated process and a closed control loop without using process simulator to perform “test run” for checking operation of process control.

(SPLR computational expressions may also be “test run” off line: signals may be applied to the input terminals, and the corresponding outputs measured).

- **Function of storing programs in ROM.**

Control and computational expressions which have been successfully “test run” can be stored into ROM by the programmer.

- **Function to read and print programs in ROM.**

This programmer can read application programs – control and computational expressions – from ROM into the programmer's RAM memory, where they may be edited or printed out together with parameters, constants and display tables. Programs, parameters, constants, display tables and register contents may also be printed out on a printer.



Figure 2-1-1. External View of SPRG Programmer.

2-1. Standard Specifications.

Operating keyboard:

Comprises 41 keys: numeric keys, function keys, and command keys – e.g. for reading (from ROM), storing (to ROM), initializing (RAM) and test-running programs.

Indicator: Sixteen-digit alphanumeric displays for program codes, constants, display tables, input/output data etc.

ROM socket: ROM is plugged into this socket for reading or storing programs and data in ROM.

Connection to instrument: Special cable, 0.6-m long, with connector.

Connection to printer: Special cable for printer. Cable length: 2 m (6.6 ft).

Programmer used with: SLPC Programmable Indicating Controller (Styles A and E), SLMC Programmable Indicating Controller with pulse width output (Styles A and E), SCMS Programmable Computing Station, SPLR Programmable Computing Unit, Model 5²₃47 IPL Computing Station (order acceptance is discontinued), Model 5²₃55 IPL Computing Unit (order acceptance is discontinued).

Power and Ground Wiring: JIS C 8303 two-pole plug with earthing contact (IEC A5-15, UL498). Cable length: 2 m (6.6 ft).

Power supply: Two versions, for “100 V” (standard) or “220 V” (option /A2ER). Both versions may use AC or DC, without change to the instrument:

Version	100 V	220 V
DC (polarity reversible)	20 to 130 V	120 to 340 V
AC (47 to 63 Hz)	80 to 138 V	134 to 264 V

Maximum power consumption:

- 330 mA (with 24 V DC supply).
- 11.2 VA (with 100 V AC supply).
- 15.3 VA (with 220 V AC supply).

Insulation resistance:

Between ROM socket pin and ground terminal:
100 MΩ (with a 500 V DC insulation tester).

Dielectric strength:

- Between ROM socket pin and ground terminal:
500 V AC for 1 min.
- Between power terminal and ground terminal:
1000 V AC for 1 min. (100 V version).
1500 V AC for 1 min. (220 V version).

Outside dimensions: 255 X 155 X 95 mm (10.0 X 6.1 X 3.7 in.).

Weight: 1.8 kg (4.0 lb).

2-2. Model and Suffix Codes.

Model	Suffix codes	Style	Description
SPRG		Programmer
	- 000.....		Always 000
Style Code		*E	Style E
Option		/A2ER	220 V power supply

2-3. Options.

/A2ER: For “220 V version” power supply.

2-4. Accessories.

- Tool for pulling ROM from socket 1 piece.
- Conversion plug for two-pole socket 1 piece.
- Extension card for SPLR 1 piece.
- Fuse (1 A) 1 piece.

Note: The fuse (S9510VK) is the dedicated fuse, Do not use it for other products.

3. INSTALLATION.

3-1. Installation.

The SPRG programmer is designed to be placed on a work bench. It is recommended to provide a work-bench large enough to hold the programmer, other instruments to be used with it, and a printer.

Normal Operating Conditions

Ambient temperature: 0 to 40°C (32 to 104°F).

Ambient humidity: 5 to 90% Relative Humidity (non-condensing).

~~~~~  
**CAUTION**  
 ~~~~~

Before connecting or disconnecting the cable, remove the power from both the programmer and the associated instrument (e.g. SLPC/SPLR). Do not remove the SPRG power cable with the power turned ON.

3-2. Cable Connection.

3-2-1. Cable Connection Procedures.

- (1) Turn OFF the power for the SPRG and associated instruments (programmable indicating controller, computing station or unit).
- (2) Set the SPRG to PROGRAM mode.
- (3) Connect the SPRG cable connector to the programmable indicating controller or computing unit (see Subsections 3-2-3 through 3-2-6).
- (4) Turn ON the SPRG power. (For 220V power supply, plug the SPRG.)
- (5) Turn ON the power for associated instruments.

3-2-2. Cable Disconnection Procedures.

- (1) Set the SPRG to PROGRAM mode.
- (2) Turn OFF the power for the associated instruments.
- (3) Turn OFF the SPRG power. (For 220V power supply, unplug the SPRG.)
- (4) Disconnect the SPRG cable connector from the associated instruments.

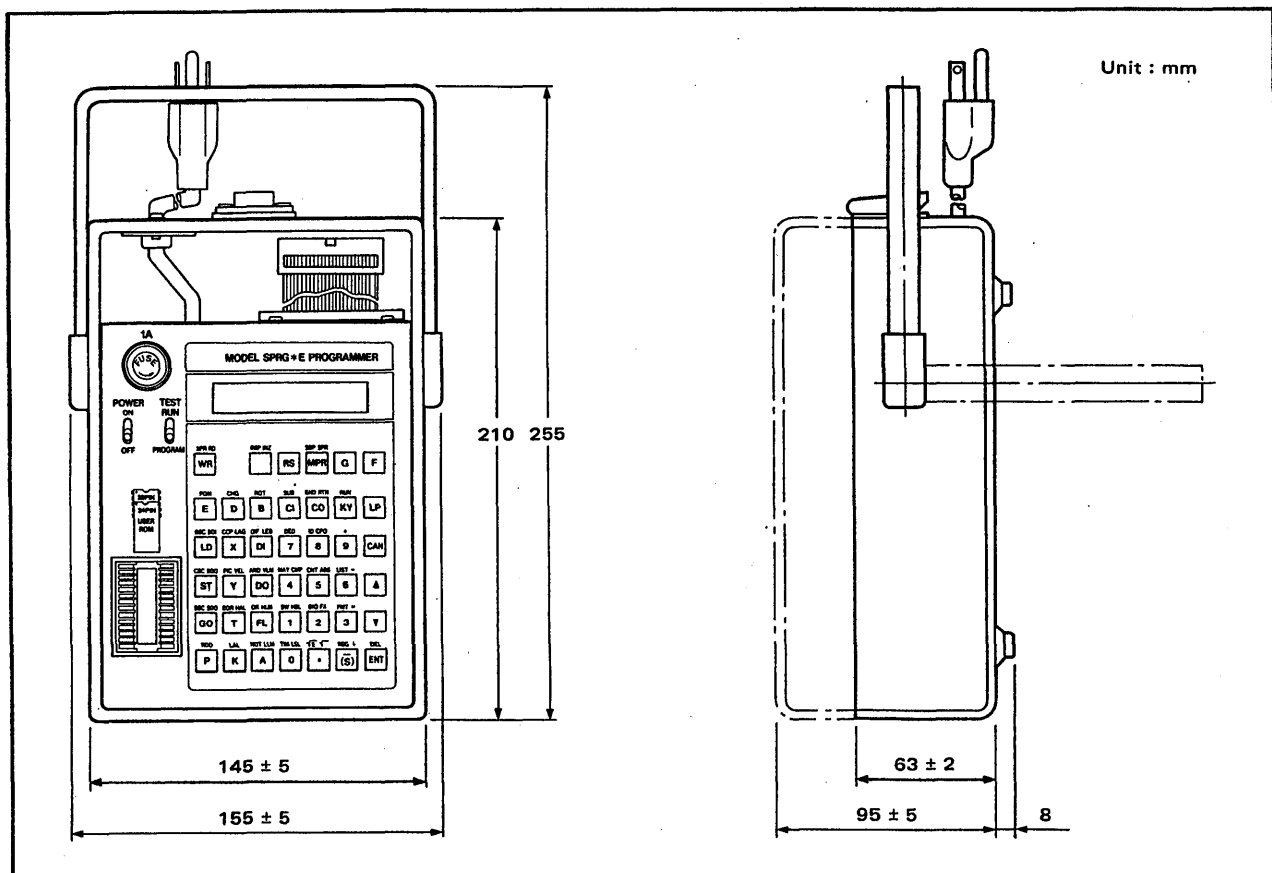

Figure 3-1-1. Outside Dimensions of SPRG.

3-2-3. Connecting SPRG to SLPC, SLMC or SCMS.

Refer to Figure 3-2-1.

- (1) Withdraw the SLPC, SLMC, or SCMS from its housing until it stops at the "service" position. Remove the side cover to access the "programmer" socket (see Figure 3-2-1).
- (2) Insert the SPRG programmer cable connector in the SLPC, SLMC, or SCMS socket so the two marks (▲) coincide.

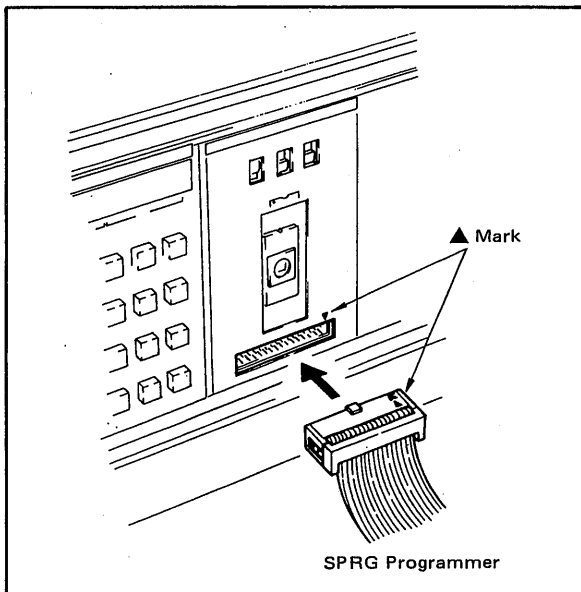

Figure 3-2-1. Connection to SLPC, SLMC or SCMS.

3-2-4. Connecting SPRG to SPLR Programmable Computing Unit.

- (1) When the SPLR module is removed from its housing, a connector socket appears (see Figure 3-2-2).
- (2) Insert the SPRG programmer connector so that the triangle mark (▲) coincides with that on the corresponding SPLR socket.
- (3) Use an extension card to connect the SPLR module to the connector in the housing.

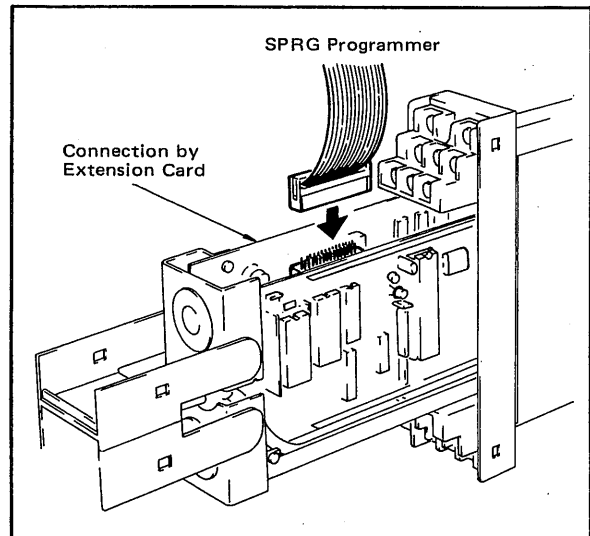

Figure 3-2-2. Connection to SPLR.

3-2-5. Connecting SPRG to IPL Computing Station.

Refer to Figure 3-2-3.

- (1) When the IPL module is removed from its housing, connector socket CN2 appears on its left side.
- (2) Open the lock lever of socket CN2, and insert the SPRG connector so that its triangle mark (▲) coincides with that on the socket. Complete the lock lever.

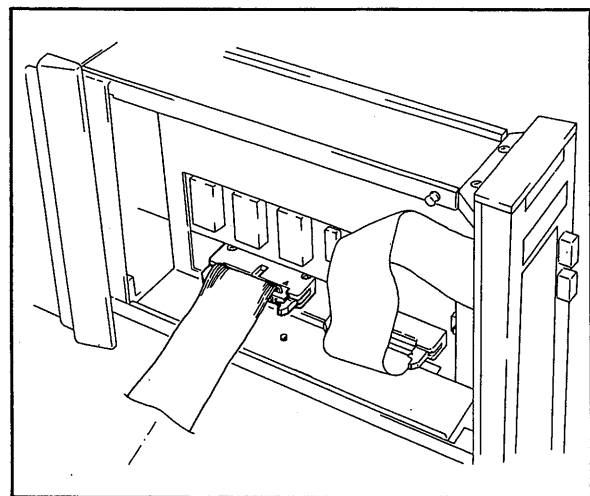

Figure 3-2-3. Connection to IPL Computing Station.

3-2-6. Connecting SPRG to IPL Computing Unit.

Refer to Figure 3-2-4.

- (1) When the IPL module is drawn from its rack housing, connector socket CN2 appears on its left side.
- (2) Open the lock lever of socket CN2, and insert the SPRG connector so that its triangle mark (▲) coincides with that on the socket. Complete the lock lever.

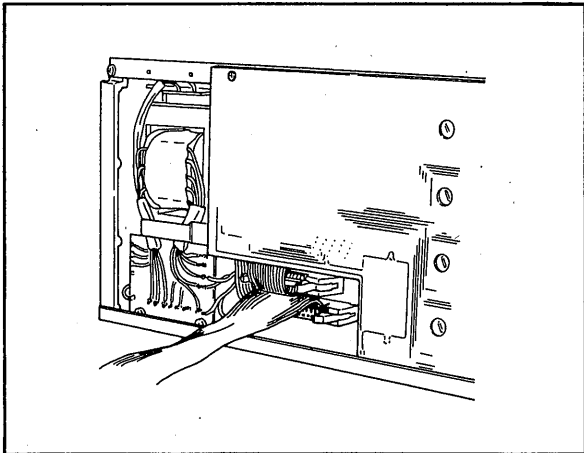

Figure 3-2-4. Connection to IPL Computing Unit.

3-2-7. Connecting SPRG to Printer.

Refer to Figure 3-2-5.

- (1) The printer connection socket is on the left side of SPRG.
- (2) Insert the printer connector (the plug can be only inserted one way).

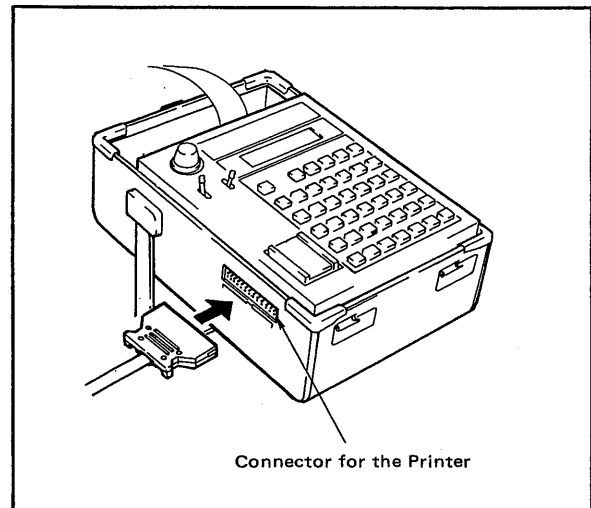

Figure 3-2-5. Connection of Printer.

3-2-8. Turning ON the Power.

After connecting the above-mentioned cables, connect the power plug.

4. PRINCIPLES OF OPERATION.

4-1. Principles of Operation.

When a programmable instrument such as SLPC and the SPRG Programmer are connected together, the operating principles of the system are as shown in Figure 4-1-1. The programmer – consisting of ROM, RAM and interface – is controlled by the CPU of the instrument connected to the programmer. A switch on the programmer selects program mode or test run mode. In program mode, the program is stored in RAM-2. The procedure is as follows:

1. Press the programmer keys to enter a program, or
2. Transfer the program from User ROM mounted in the instrument to RAM-2 of the programmer, or
3. Insert User ROM into the socket on the programmer to transfer its program to RAM-2.

After storing the program in RAM-2 by the above procedure, switch the system to “test run” mode so that the program – including I/O signals to/from the process – will be executed.

For the SLPC, SLMC or SCMS, it is possible not only to store a process model (a program which simulates the process) into RAM-2 but also to test the closed loop operation of the controller off line using the process model. Data in each register can be displayed on the programmer display. This is convenient for program debugging. Parameters can be changed, by pressing the programmer keys, even when the system is in test run mode.

If programs are satisfied, install ROM which is not written in the programmer ROM socket and write a program stored in RAM-2. Parameters set by the programmer tuning panel are stored in ROM of the SLPC, SLMC or SCMS as initial values. The contents of ROM appear on the SPRG Programmer display. So you can check them.

After a program is stored in ROM, the ROM is plugged into an SLPC instrument, the programmer is disconnected, and the instrument can then execute the program by itself.

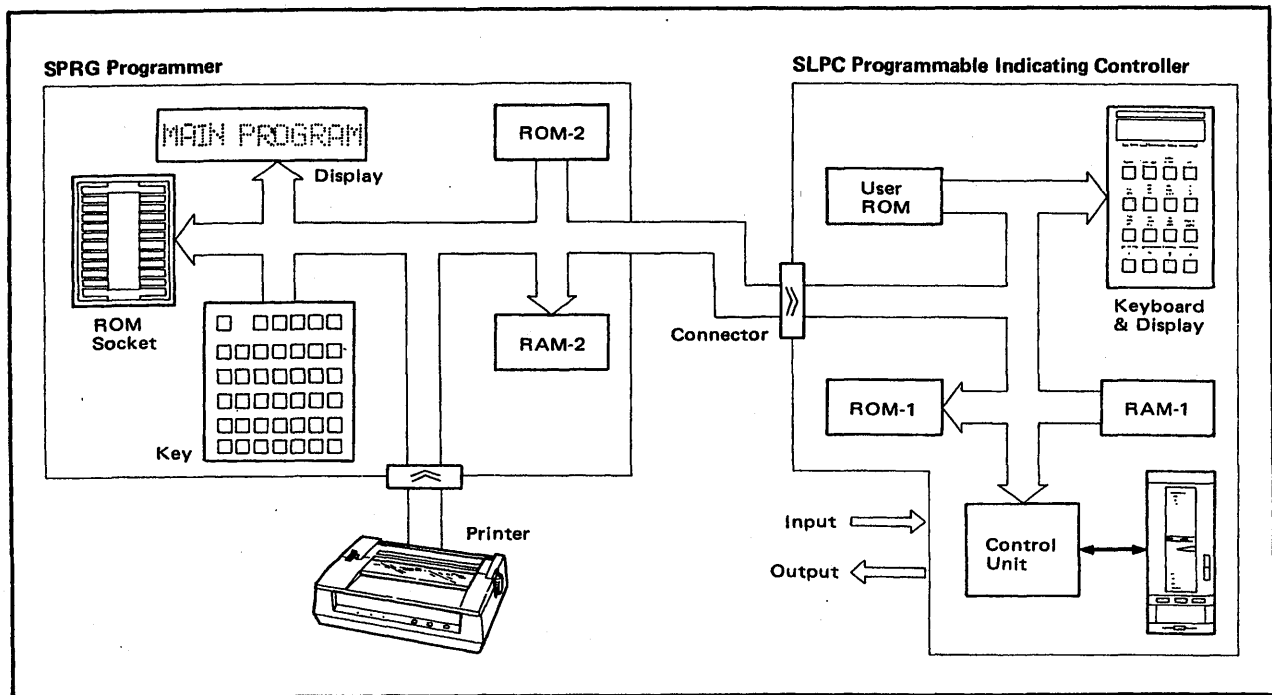

Figure 4-1-1. Principles of Operation.

4-2. Simple Program, Example-1.

For easy handling of this instrument, some simple programs are generated. Detailed key operations are described in Section 5.

DC voltage/current standard : YOKOGAWA's Model 7651 or equivalent

Digital voltmeter : YOKOGAWA's Model 7562 or equivalent

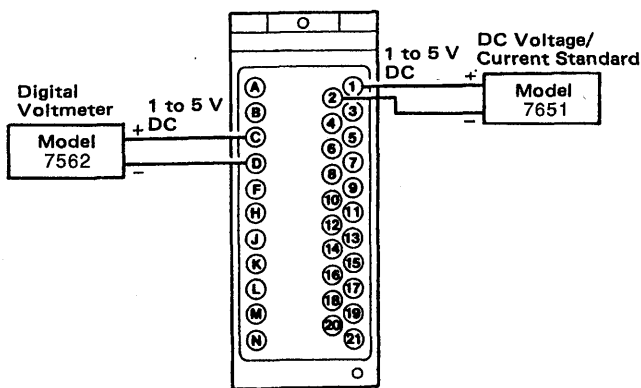

Figure 4-2-1. Wiring Diagram for SLPC, SLMC, or SCMS Test Run.

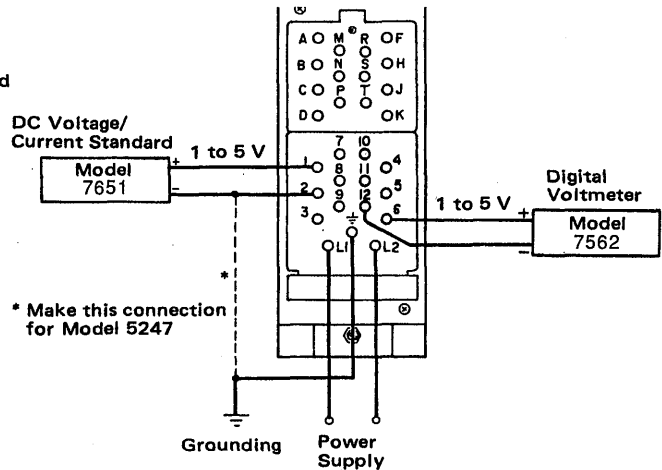

Figure 4-2-3. Wiring Diagram for IPL Station (Model 5²₄₇) Test Run.

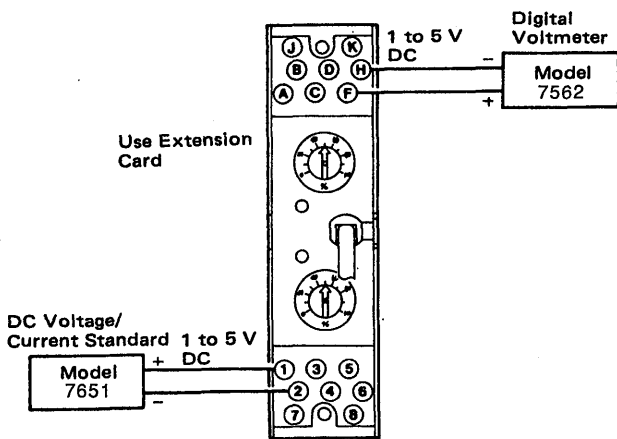

Figure 4-2-2. Wiring Diagram for SPLR Test Run.

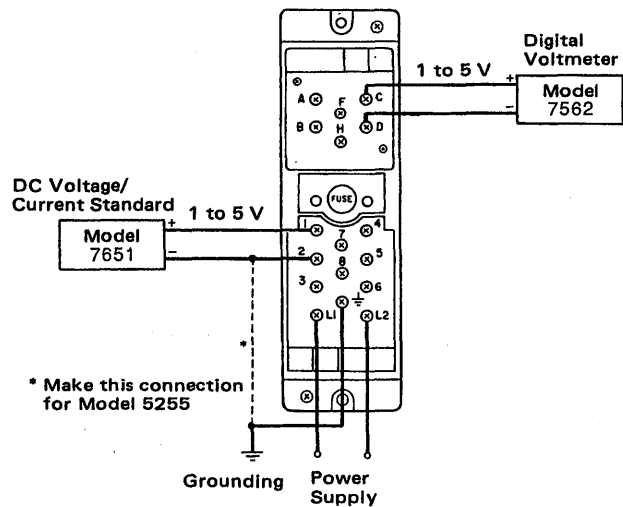

Figure 4-2-4. Wiring Diagram for IPL Unit (Model 5²₅₅) Test Run.

4-2-1. Preparation.

1. Connect the SPRG Programmer and test instruments as shown in Figures 4-2-1 through 4-2-4 to check that operation of the Programmer in test run mode is normal. Leave the power supplies disconnected.
2. Set the TEST RUN/PROGRAM switch to PROGRAM mode.
3. Connect the instrument and the programmer as illustrated in Section 3-2.
4. Connect the programmer to the power supply, but leave its power switch turned off. (No power switch for the SPRG of 220V power supply.)
5. Turn ON the programmer power switch. Connect power to the programmable instrument and test instruments and allow time for warming up. (No power switch for the SPRG of 220V power supply.) For the IPL unit, the fail indicator lamp (red) lights, and the fail contact opens. This operation is normal.

6. Key operation Programmer display

		MAIN PROGRAM
(1)	<input type="button" value="F"/>	m 1 F
(2)	<input type="button" value=""/>	INIT PROGRAM
	After a moment	MAIN PROGRAM
(3)	<input type="button" value="G"/>	m 1 G
(4)	<input type="button" value=""/>	INIT PARAMETER
	After a moment	MAIN PROGRAM

These key operations prepare the programmer to accept a new program (pressing and keys in sequence has the function -- initialize). Refer to Subsections 5-3-1 and 5-3-2.

4-2-2. Programming.

1. As an example, enter the simple program shown below.

```
01 LD X1
02 ST Y2
03 END
```

This program reads input signal 1 and provides output signal 2 (1 to 5 V DC).

2. Key operation Programmer display

		MAIN PROGRAM
(1)	<input type="button" value="LD"/>	m 1 LD
(2)	<input type="button" value="X"/>	m 1 LD X >
(3)	<input type="button" value="1"/>	m 1 LD X 1
	Completion of the first step	
(4)	<input type="button" value="ST"/>	m 2 ST
(5)	<input type="button" value="Y"/>	m 2 ST Y >
(6)	<input type="button" value="2"/>	m 2 ST Y 2

Completion of the second step

(7)	<input type="button" value="END"/> (= <input type="button" value="G"/> <input type="button" value="CO"/>)	m 3 END
-----	------------------------------------------------------------------------------------------------------------	---------

Completion of the third step

Press the keys in order of program steps.

The symbol >, which appears while keying in program steps, prompts the user to enter more information to complete a program step.

If key entry is invalid, press the (cancel) or (delete) key (see Subsections 5-3-12 and 5-3-16).

3. Press the and keys to confirm that the program entry is correct.

Key operation Programmer display

		m 3 END
(1)	<input type="button" value="MPR"/>	MAIN PROGRAM
(2)	<input type="button" value="▲"/>	m 1 LD X 1
(3)	<input type="button" value="▲"/>	m 2 ST Y 2
(4)	<input type="button" value="▲"/>	m 3 END

4-2-3. Test Run.

Confirm that the program runs normally (producing an output corresponding to the applied input) by a test run:

1. Set the TEST RUN/PROGRAM switch to TEST RUN.

2. Key operation Programmer display

		m 3 END
(1)	<input type="button" value="RUN"/> (= <input type="button" value="G"/> <input type="button" value="KY"/>)	TEST RUN

3. Vary the input voltage -- applied to the instrument from the voltage source -- within the range of 1 to 5 V DC. The reading on the digital voltmeter connected to the output terminal of the instrument should coincide with the output voltage from the voltage source.

4. For the SLPC (or SLMC) Programmable Indicating Controller, when X1 is selected using the tuning panel keyboard on the side of the controller, the SLPC (or SLMC) displays the values between 0.0 and 100.0 corresponding to input signals within the range 1 to 5 V DC. Y2 can be selected and displayed in the same way as for X1.
5. For the SCMS Programmable Computing Station, select X1 with the data selection key. The SCMS displays 0.0 to 100.0 when the input signal of 1 to 5 V DC is applied. Y2 can be selected and displayed in the same way.
6. For the Model 5₃47 IPL Computing Station, when the upper display select lamp is lighted, the display varies between 0.0 and 100.0 in response to variation of the input signal within the range 1 to 5 V DC. Y2 can be selected by the selector switch and displayed in a similar manner.
7. The contents of the input and output registers can be displayed on the programmer display.

Key operation	Programmer display
(1) <input type="button" value="X"/> <input type="button" value="1"/>	X 1 □□□□□
(2) <input type="button" value="Y"/> <input type="button" value="2"/>	Y 2 □□□□□

4-2-4. Specifying Display Table.

In the previous section, the values displayed by the SLPC, SLMC, SCMS or IPL Station are within the range 0.0 to 100.0. The following steps show how to display the I/O values in actual engineering units (for example, a range of 1.000 to 5.000) corresponding to an input signal variation within the range 1 to 5 V DC.

1. Set the TEST RUN/PROGRAM switch again to PROGRAM. For the IPL, wait until the fail lamp lights before operating the keys.

2. Key operation

- (1)
- (2)
- (3)
- (4)

Programmer display
MAIN PROGRAM

X>
X1H 100.0
X1L 000.0
X1H 100.0

Each time the key is pressed, the display toggles between the high and low range limits of X1 (in engineering units).

3. Specify X1.

Key operation

- (1)
- (2)
- (3)
- (4)
- (5)
- (6)

Programmer display

X1H 100.0
X1H 5
X1H 5.
X1H 5.0
X1H 5.00
X1H 5.000

After the numeric value 5.000 has disappeared momentarily,

X1H 5.000

Always press the key after keying in a numeric value.

- (7)
- (8)
- (9)
- (10)
- (11)
- (12)
- (13)

X1L 0.000
X1L 1
X1L 1.
X1L 1.0
X1L 1.00
X1L 1.000
X1L 1.000

After the numeric value 1.000 has disappeared momentarily,

X1L 1.000

4. The output signals can be displayed in engineering units in a manner similar to that shown above.
5. Set the TEST RUN/PROGRAM switch to the TEST RUN position, and press the key. Confirm that the value on the display corresponds exactly to the signal from the voltage source. (Since the display table is set to display the range 1.000 to 5.000, the displayed value should coincide with the input voltage from the voltage source).

4-3. Simple Program, Example-2.

4-3-1. Preparation.

Use the same procedure as described in subsection 4-2-1 to set up the instruments. The wiring diagrams are shown in Figures 4-3-1 through 4-3-4.

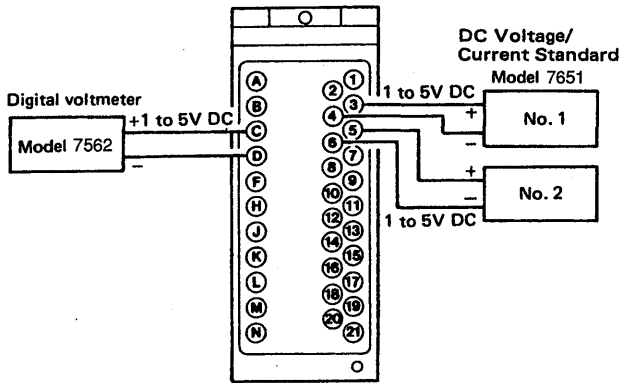

Figure 4-3-1. Wiring Diagram for SLPC, SLMC or SCMS Test Run.

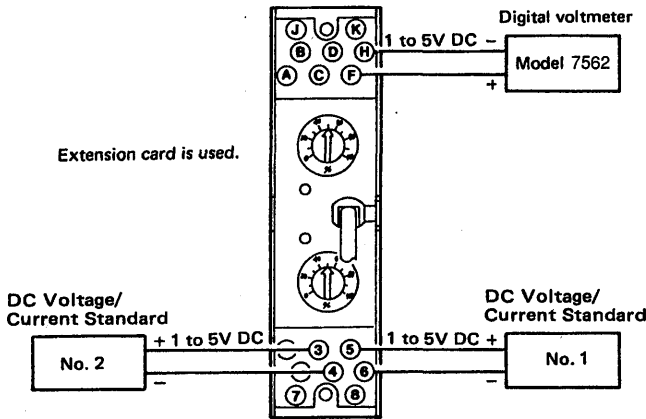

Figure 4-3-2. Wiring Diagram for SPLR Test Run.

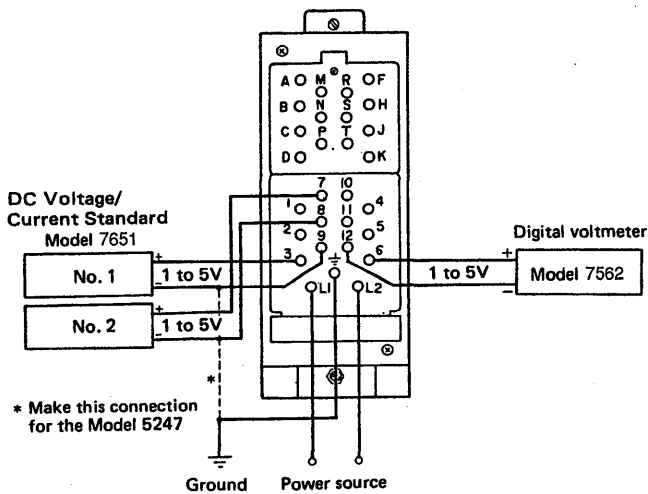

Figure 4-3-3. Wiring Diagram for an IPL Station (Model 5²47) Test Run.

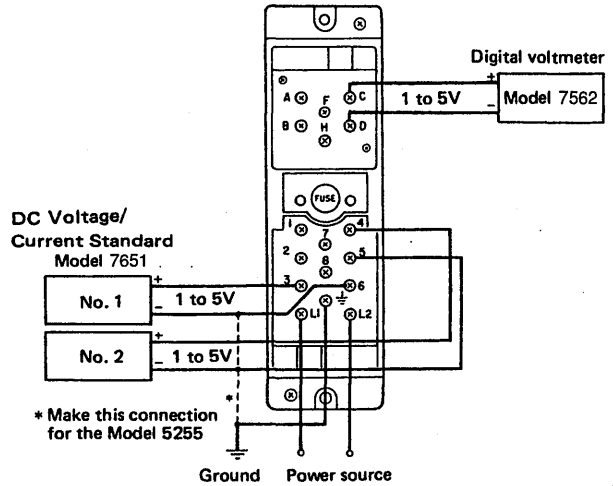

Figure 4-3-4. Wiring Diagram for IPL Unit (Model 5²55) Test Run.

4-3-2. Programming.

The following program outputs the sum of two input signals. Suppose that the application is an actual manufacturing process where flows of two different materials have to be blended.

Flow rate 1: 0 to 600 l/h

Signal of 1 to 5 V DC with linear characteristic

Flow rate 2: 0 to 200 l/h

Signal of 1 to 5 V DC with linear characteristic

In this case, when the two flows are combined, the flow rate will be

Flow rate: 0 to 800 l/h

Signal of 1 to 5 V DC with linear characteristic

Assign input and output signals as follows: assign flow rate 1 to No. 2 input, flow rate 2 to No. 3 input, and output to No. 2 output. The wiring diagrams are as shown in Figures 4-3-1 through 4-3-4.

1. Program

01	LD	X2	
02	LD	K01	K01 = 0.750
03	x		
04	LD	X3	
05	LD	K02	K02 = 0.250
06	x		
07	+		
08	ST	Y2	
09	END		

X2 (100% input represents 600 l/h) and X3 (100% input represents 200 l/h) are multiplied by K01 = 0.75 (75%) and K02 = 0.25 (25%) respectively. Thus, the ratio K01:K02 = 600:200, and the sum K01 + K02 = 1.00 (100%).

2. Key operation

Programmer display

		MAIN PROGRAM
(1)	[LD] [X] [2]	m 1 LD X 2
(2)	[LD] [K] [0] [1]	m 2 LD K 1
(3)	[*] (= [F] [3])	m 3 *
(4)	[LD] [X] [3]	m 4 LD X 3
(5)	[LD] [K] [0] [2]	m 5 LD K 2
(6)	[*]	m 6 *
(7)	[+] (= [F] [9])	m 7 +
(8)	[ST] [Y] [2]	m 8 ST Y 2
(9)	[END]	m 9 END
(10)	[K] [0] [1] [0] [.] [7] [5] [0]	K 0 1 0.750
(11)	[ENT]	K 0 1 0.750
(12)	[K] [0] [2] [0] [.] [2] [5] [0]	K 0 2 0.250
(13)	[ENT]	K 0 2 0.250

4-3-3. Test Run.

Confirm that the instrument performs the keyed-in program correctly.

1. Set the TEST RUN/PROGRAM switch to the TEST RUN position.

2. Key operation

Programmer display

		TEST RUN
(1)	[RUN]	X 2 □□□□
(2)	[X] [2]	

3. When the output of the voltage source connected to the No. 2 input terminal of the instrument is varied within the range 1 to 5 V DC, the programmer displays for inputs of 1 V and 5 V should be 0.000 and 1.000 respectively.

4. When keys [X] and [3] are pressed in sequence, the reading on the programmer display corresponds to input signal 3.

5. When the keys [Y] and [2] are pressed in turn, the programmer displays 0.000 when the digital voltmeter No.2 reads a 1 V DC output, and 1.000 when it reads a 5 V DC output.

6. Vary the two inputs, and confirm that the relationship between inputs and output is correct.

4-3-4. Changing Constants during Test Run.

While checking a program in test run mode, sometimes constants must be changed so that results correspond with actual process quantities. In such cases, the constants Kn can be changed during test run mode.

1. Suppose that – when using the program described in Section 4-3-3 – it becomes necessary to change the flow rates as a result of a test run.

Flow rate 1: 0 to 600 l/h

(Remains unchanged)

Flow rate 2: 0 to 400 l/h

(Changed from 0 to 200 l/h)

Thus, when these two flow rates are combined, we obtain

Flow rate: 0 to 1000 l/h

As a result, the constants have to be changed to K01 = 0.6 (60%) and K02 = 0.4 (40%) respectively.

2. The following key operations have to be performed during test run mode to make the changes.

Key operation

Programmer display

(1)	[K] [0] [1] [0] [.] [6] [0] [0]	K 0 1 0.600
(2)	[ENT]	K 0 1 0.600
(3)	[K] [0] [2] [0] [.] [4] [0] [0]	K 0 2 0.400
(4)	[ENT]	K 0 2 0.400

3. Vary the two inputs, and confirm that the relationship between the input and output “flow rates” is appropriate.

4-3-5. Specifying Display Table.

For the SLPC, SLMC, SCMS or IPL Station, variables Xn and Yn, and parameters Pn can be displayed in engineering units. Prepare the display table according to the procedure described in subsection 4-2-4.

5. OPERATION.

5-1. Front Panel Features.

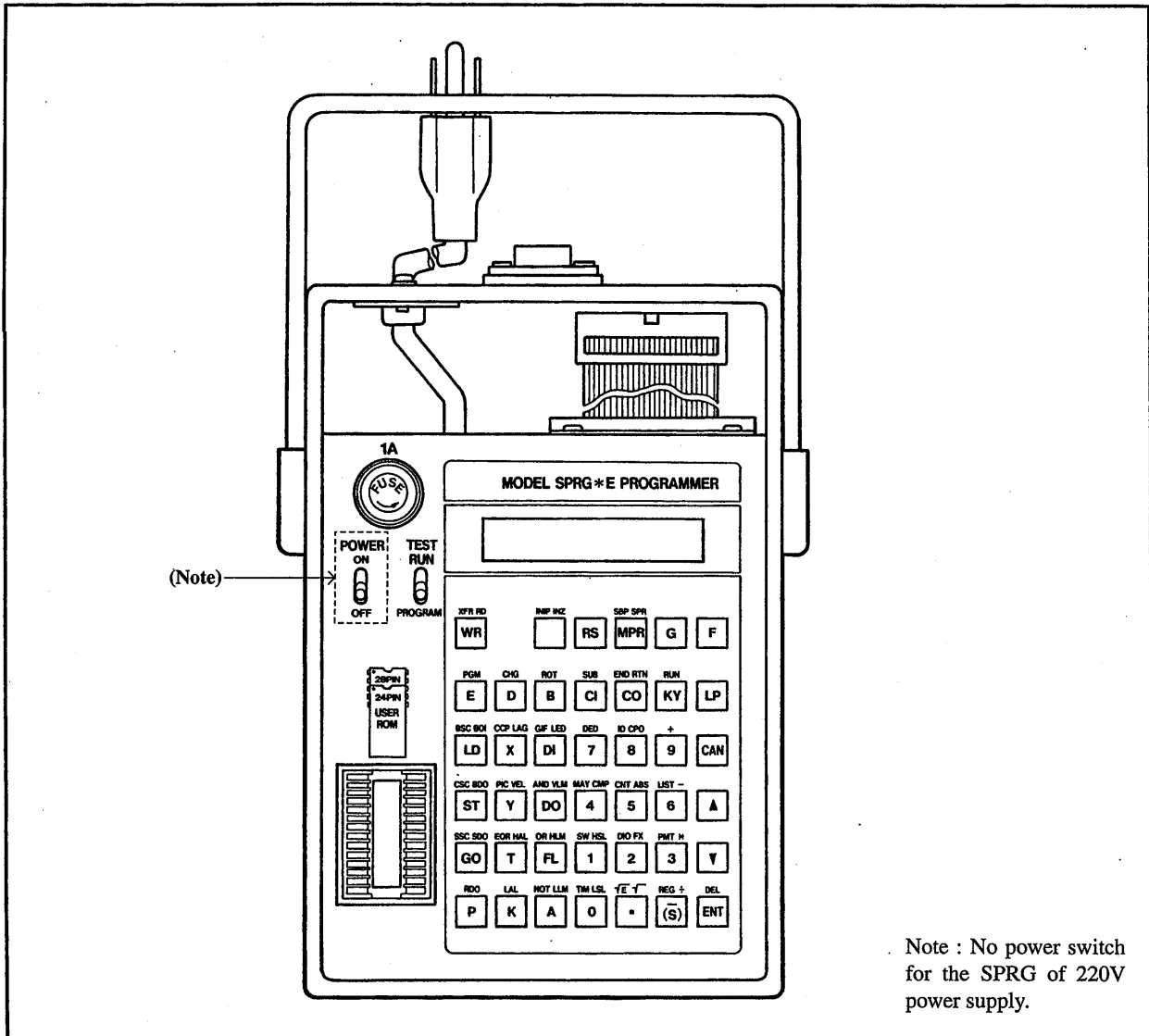

Note : No power switch for the SPRG of 220V power supply.

Figure 5-1-1. Front Panel Features.

5-2. Toggle Switches.

5-2-1. Mode (TEST RUN/PROGRAM) Switches.

1. PROGRAM

When the switch is at the PROGRAM position, a program may be input from the programmer keyboard to its memory. Constants, display table (for SLPC, SLMC, SCMS and IPL station) and control mode CNT (SLPC, SLMC and SCMS) may also be input.

Programs stored in User ROM can be transferred to RAM in the Programmer, and test run or modi-

fied.

2. TEST RUN

When the switch is at the TEST RUN position, pressing the **RUN** key initiates a program in an (SLPC etc.) instrument. In Test Run Mode, register (variable) contents may be checked. (The displayed input register contents are the values read each computational cycle before the user program is executed, the output register contents are the values output at the end of the user program).

5-2-2. Power Switch (POWER ON/OFF).

ON: Power applied.

OFF: Power disconnected.

(No power switch for the SPRG of 220V power supply.)

5-3. Programmer Control Keys.

5-3-1. **[F]** (Shift key).

Pressing **[F]** shifts the next key pressed: it takes the function indicated in blue above the key. For example, when **[F]** and **[X]** keys are pressed in sequence, the program instruction "LAG" is entered (see **[X]** key in Figure 5-1-1). In this manual, these two key operations may simply be expressed as **[LAG]**.

5-3-2. **[G]** (Shift key).

Pressing **[G]** shifts the next key pressed: it takes the function indicated in yellow above the key. For example, when **[G]** and **[DO]** keys are pressed in sequence, the program instruction "AND" is entered (see **[DO]** key in Figure 5-1-1). In this manual, these two key operations may simply be expressed as AND.

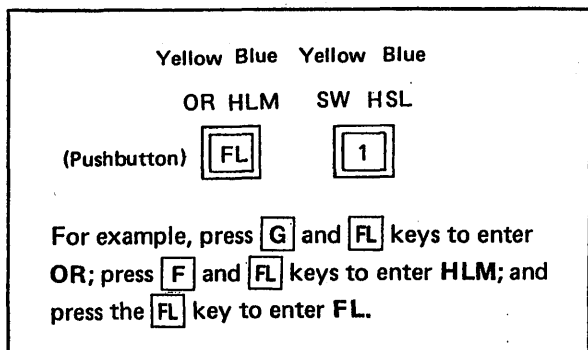

Figure 5-3-1. How to Operate **[F]** and **[G]** Keys.

5-3-3. **[MPR]** (Main program key).

Programs consist of the main program, subprograms and simulation programs. Press the **[MPR]** key to call the head of the main program. Programs which can be used for each instrument are as follows:

	SLPC*E	SLPC*A	SLMC*E	SLMC*A	SCMS	SPLR	5247	5255
Main Program	○	○	○	○	○	○	○	○
Subprogram	○	-	○	-	○	-	-	-
Simulation Program	○	○	○	○	○	-	-	-

*E: Style E
○: Can be used
-: Cannot be used

5-3-4. **[SBP]** (Subprogram key).

[= **[G]** **[MPR]**]

Press the **[SBP]** (subprogram) key to call the head of the subprograms (up to 99 program steps can be described).

5-3-5. **[SPR]** (Simulation program key)

[= **[F]** **[MPR]**].

Pressing this key specifies the head of a process simulation program (process model) used for an off line closed loop test run of an SLPC, SLMC or SCMS program. The program can be up to 20 steps long.

5-3-6. **[INZ]** (Program-erasing key) [= **[F]** **[]**].

Press this key before entering a new program to erase previous programs, constants and display tables.

5-3-7. **[RS]** (Reset key).

This key is used to return the program to its starting point. In test run mode, pressing this key resets register variables Xn Yn and digital I/O and restarts the user's program from the beginning. In program mode, pressing this key changes the program location to its starting point, and the programmer waits for further commands.

5-3-8. **[WR]** (Program-write key).

Pressing this key stores a program (including constants and display tables) from programmer RAM into a blank ROM inserted into the ROM socket.

5-3-9. **[RD]** (Program-read key) [= **[F]** **[WR]**].

Pressing this key reads the contents of the ROM in the programmer ROM socket into programmer RAM memory.

5-3-10. **[XFR]** (Program transfer key) [= **[G]** **[WR]**].

Pressing this key transfers a program from User ROM in an instrument (SLPC etc.) connected to the programmer to RAM in the programmer.

5-3-11. **[RUN]** (Test run execution key) [= **[G]** **[KY]**].

When the TEST RUN/PROGRAM switch is set to the TEST RUN position, pressing this key makes the instrument connected to the programmer execute the program in programmer RAM memory in test run mode.

5-3-12. **CAN** (Clear — partial erasure — key).

Aborts entry of a single program step.

1. This key aborts entry of a partially-complete program step. Operating this key moves the display back one program step. If the last program step entered is complete, this key does not delete it — use the **DEL** key instead.
2. This key can also be used to abort entry of constants Kn, temporary variables Tn and display table items (for SLPC, SLMC, SCMS and IPL Station).

5-3-13. **▲** (Forward-step key).

Pressing this key moves the program display one step forward. Thus, it can be used to display the program step by step, or to move to a program step that must be changed. After step 99 is reached, pressing the key again reverts the display to step 01.

5-3-14. **▼** (Back-step key).

This key is used to display the previous program step. After step 01 is reached, pressing the key again jumps the program display to step 99.

5-3-15. **ENT** (Entry key).

In program mode, this key is used (after typing in numeric data) to enter settings for constants Kn, display table, and the numeric value of CNTn (SLPC, SLMC or SCMS) into the programmer. In test run mode, this key is used (after typing in numeric data) to enter new settings for constants, parameters and the numeric values of various registers. In register print mode, this key is used to initiate printout.

5-3-16. **DEL** (Delete program step key)

[= **F** **ENT**].

This key is used to modify a program. Each time this key is pressed, the currently-displayed program step is erased and the previous program step is displayed.

5-3-17. **INP** (Parameter erasing key) [= **G** **□**].

This key is used to initialize the tuning parameters of the instrument connected to the SPRG (cannot be used for SPLR and IPL).

5-4. Numeric Keys.

0 **1** to **9** **□** **(S)**

These keys are used to input numeric values, e.g. data, register numbers, and step numbers which are the target of jump instructions.

The **□** key is for entering the decimal point. Entries may have up to three digits below the decimal point. (**□□□□** = four digits below the decimal point is illegal).

The **(S)** key enters a minus sign in front of a number.

For example, to enter -0.500, press the keys **(S)**

0 **□** **5** **0** **0** in order (pressing the keys **0** **□** **5** **0** **0** **(S)** in order is invalid).

5-5. Register Keys.

These keys are used with commands LD and ST for creating programs. When only the register keys are pressed, data is displayed. Instruments for which register keys can be used are shown below.

Register		SLPC*E	SLPC*A	SLMC*E	SLMC*A	SCMS	SPLR	5 $\frac{2}{3}$ 47	5 $\frac{2}{3}$ 55
Numeric Data Register	X Input Register	○	○	○	○	○	○	○	○
	Y Output Register	○	○	○	○	○	○	○	○
	T Temporary Storage	○	○	○	○	○	○	○	○
	K Constant	○	○	○	○	○	○	○	○
	P Parameter	○	○	○	○	○	○	○	○
	A Control Parameter	○	○	○	○	—	—	—	—
	B Control Parameter	○	—	○	—	—	—	—	—
	D Send Data	○	—	○	—	○	—	—	—
	E Receive Data	○	—	○	—	○	—	—	—
	Status Register	D I Status Input	○	○	○	○	○	○	○
D O Status Output		○	○	○	○	○	○	○	○
F L Flag		○	○	○	○	○	○	—	○
C I Send Data		○	—	○	—	○	—	—	—
C O Receive Data		○	—	○	—	○	—	—	—
K Y Key Input		○	—	○	—	○	—	—	—
L P Lamp Output		○	—	○	—	○	—	—	—

○ Can be used.
— Cannot be used.

5-6. DIO Designation Key **DIO** [= **G** **2**].

This key is used to designate DIO (digital I/O) terminals for the SLPC*E, SLMC*E and SCMS.

5-7. CNT Designation Key $\boxed{\text{CNT}}$ [= $\boxed{\text{G}}$ $\boxed{5}$].

CNT1: Designates control elements in control loop No.1.

CNT2: Designates control elements in control loop No.2.

CNT3: Designates auto selector for selector control.

CNT4: Designates computation cycles.

CNT5: Designates computation expressions.

Instruments for which CNTs can be used are shown below.

	SLPC*E	SLPC*A	SLMC*E	SLMC*A	SCMS	SPLR	5 $\frac{2}{3}$ 47	5 $\frac{2}{3}$ 55
CNT 1	○	○	○	○	—	—	—	—
CNT 2	○	○	—	—	—	—	—	—
CNT 3	○	○	—	—	—	—	—	—
CNT 4	○	—	—	—	○	—	—	—
CNT 5	○	—	○	—	—	—	—	—

5-8. Computational and Control Program Keys.

Program keys correspond to computational and control functions of SLPC, SLMC, SCMS, SPLR and IPL. A program is generated by keying in a sequence of program steps. Some computational/control functions do not apply to all instruments – see Table 5-8-1 for details of which functions apply to which instruments.

Table 5-8-1. Computational and Control Functions in Different Programmable Instruments (Continued).

Category	Instruction Code	Instruction	Programmer Display	Instruments								
				SLPC*E	SLPC*A	SLMC*E	SLMC*A	SCMS	SPLR	5 ² / ₃ 47	5 ² / ₃ 55	
Load	LDXn	Read Xn	LD Xn	○	○	○	○	○	○	○	○	
	LDYn	Read Yn	LD Yn	○	○	○	○	○	○	○	○	
	LDPmn	Read Pmn	LD Pmn	○	○	○	○	○	○	○	—	
	LDKmn	Read Kmn	LD Kmn	○	○	○	○	○	○	○	○	
	LDTmn	Read Tmn	LD Tmn	○	○	○	○	○	○	○	○	
	LDAmn	Read Amn	LD Amn	○	○	○	○	—	—	—	—	
	LDBmn	Read Bmn	LD Bmn	○	—	○	—	—	—	—	—	
	LDFLmn	Read FLmn	LD FLmn	○	○	○	○	○	—	—	—	
	LDDImn	Read DImn	LD DImn	○	○	○	○	○	○	—	—	
	LDDOm	Read DOmn	LD DOmn	○	○	○	○	○	○	—	—	
	LDEmn	Read Emn	LD Emn	○	—	○	—	○	—	—	—	
	LDDmn	Read Dmn	LD Dmn	○	—	○	—	○	—	—	—	
	LDCImn	Read CImn	LD CImn	○	—	○	—	○	—	—	—	
	LDCOm	Read COmn	LD COmn	○	—	○	—	○	—	—	—	
	LDKYn	Read KYn	LD KYn	○	—	○	—	○	—	—	—	
LDLPn	Read LPn	LD LPn	○	—	○	—	○	—	—	—		
Store	STXn	Store into Xn	ST Xn	○	○	○	○	○	○	○	○	
	STYn	Store into Yn	ST Yn	○	○	○	○	○	○	○	○	
	STPmn	Store into Pmn	ST P mn	○	○	○	○	○	—	—	—	
	STTmn	Store into Tmn	ST T mn	○	○	○	○	○	○	○	○	
	STAmn	Store into Amn	ST A mn	○	○	○	○	—	—	—	—	
	STBmn	Store into Bmn	ST B mn	○	—	○	—	—	—	—	—	
	STFLmn	Store into FLmn	ST FL mn	○	○	○	○	○	—	—	—	
	STDOmn	Store into DOmn	ST DO mn	○	○	○	○	○	○	—	—	
	STDmn	Store into Dmn	ST D mn	○	—	○	—	○	—	—	—	
	STCOmn	Store into COmn	ST CO mn	○	—	○	—	○	—	—	—	
	STLPn	Store into LPn	ST LPn	○	—	○	—	○	—	—	—	
End	END	End of Program	END	○	○	○	○	○	○	○	○	
Function	Basic Functions	+	Addition	+	○	○	○	○	○	○	○	○
		—	Subtraction	—	○	○	○	○	○	○	○	○
		×	Multiplication	*	○	○	○	○	○	○	○	○
		÷	Division	/	○	○	○	○	○	○	○	○
		√	Square Root Extraction	SQT	○	○	○	○	○	○	○	○
		√E	Square Root Extraction with Locked Low Level Signal Adjustable	SQT-E	○	—	○	—	○	—	—	—
		ABS	Absolute Value	ABS	○	○	○	○	○	○	○	○
		HSL	High Selector	HSL	○	○	○	○	○	○	○	○
		LSL	Low Selector	LSL	○	○	○	○	○	○	○	○
		HLM	High Limit	HLM	○	○	○	○	○	○	○	○
LLM	Low Limit	LLM	○	○	○	○	○	○	○	○		

Table 5-8-1. Computational and Control Functions in Different Programmable Instruments.

Category	Instruction Code	Instruction	Programmer Display	Instruments								
				SLPC*E	SLPC*A	SLMC*E	SLMC*A	SCMS	SPLR	5 ² / ₃ 47	5 ² / ₃ 55	
Functions	Function with Device Addresses	FX	Segment	FX n	2 Functions, Each 10 Segments	2 Functions, Each 10 Segments	2 Functions, Each 10 Segments	2 Functions, Each 10 Segments	2 Functions, Each 10 Segments	2 Functions, Each 10 Segments	3 Segments	20 Segments
		FX	Line Segment	FX n	○	—	○	—	○	—	—	—
		LAG	First Order Lag	LAG n	○	○	○	○	○	○	○	○
		LED	First Order Lead	LED n	○	○	○	○	○	○	○	○
		DED	Dead Time	DED n	○	○	○	○	○	○	○	○
		VEL	Velocity Computation	VEL n	○	○	○	○	○	○	○	○
		MAV	Moving Average Computation	MAV n	○	—	○	—	○	○	—	—
		VLM	Velocity Limiter	VLM n	○	○	○	○	○	○	○	○
		CCD	Condition Change Detection	CCD n	○	—	○	—	○	—	—	—
		TIM	Timer	TIM n	○	○	○	○	○	○	—	—
		PGM	Program Set	PGM n	○	—	○	—	○	—	—	—
		PIC	Pulse Input Count	PIC n	○	—	○	—	○	—	—	—
	Conditional Instructions	HAL	High-Limit Alarm	HAL n	○	○	○	○	○	○	○	○
		LAL	Low-Limit Alarm	LAL n	○	○	○	○	○	○	○	○
		BDI	Branch DIn	BDI n	—	—	—	—	—	—	○	—
		BDO	Branch DOn	BDO n	—	—	—	—	—	—	○	—
		AND	Logical Product	AND	○	○	○	○	○	○	—	—
		OR	Logical Sum	OR	○	○	○	○	○	○	—	—
		NOT	Negation	NOT	○	○	○	○	○	○	—	—
		EOR	Exclusive OR	EOR	○	—	○	—	○	—	—	—
		GOmn	Jump to Step mn	GO mn	○	○	○	○	○	○	○	○
		GIFmn	Conditional Jump	GIF mn	○	○	○	○	○	○	—	—
		GO SUB mn	Jump to Sub-program mn	GO SUB mn	○	—	○	—	○	—	—	—
		GIF SUB mn	Jump to Sub-program mn	GIF SUB mn	○	—	○	—	○	—	—	—
		SUBmn	Subprogram Label	SUB mn	○	—	○	—	○	—	—	—
		RTN	Return	RTN	○	—	○	—	○	—	—	—
		CMP	Comparison	CMP	○	○	○	○	○	○	○	○
		SW	Signal Switching	SW	○	○	○	○	○	○	—	—
		Contact Output	SDO	Set DOn	SDO n	—	—	—	—	—	—	○
	RDO		Reset DOn	RDO n	—	—	—	—	—	—	○	—
	CPO		Totalizer Pulse Output	CPO n	○	○	—	—	○	○	○	—
	Register	CHG	Change S Register	CHG	○	—	○	—	○	—	—	—
		ROT	Rotate S Register	ROT	○	—	○	—	○	—	—	—
	Control Functions	BSC	Basic Control	BSC	○	○	○	○	—	—	—	—
		CSC	Cascade Control	CSC	○	○	—	—	—	—	—	—
		SSC	Selector Control	SSC	○	○	—	—	—	—	—	—

○ Can be used
 — Cannot be used

5-9. ID Number Setting Key **ID** [= **G** **8**].

ID numbers are attached to the user ROMs. These ID numbers are read by the SPRG to identify the user ROMs.

For ID numbers, use four-digit constants.

5-10. Printer Control Keys.

These keys are used to print programs or data when the UPRT printer is connected to the SPRG programmer. The printer control keys are valid only when the system is in PROGRAM mode (the **REG** key valid even in test run mode).

5-10-1. LIST (Program list key) [= **G** **6**].

This key allows program steps in a program to be printed ("listed") on the printer. Use **MPR** and **LIST** keys for printing the main program. **SBP** and **LIST** keys for printing subprograms, **SPR** and **LIST** keys for printing the process model (simulation) program.

5-10-2. PMT (Display table, constant and parameter keys) [= **G** **3**].

This key is used to print the engineering unit display tables (range min./max. values) for input signals Xn, parameters Pn constants Kn, and output signals Yn. PID parameters (for SLPC or SLMC) can also be printed by pressing this key.

5-10-3. REG (Register key) [= **G** **S**].

This key is used to print the input signals Xn, output signals Yn, temporary storage registers Tn, parameters Pn (except for IPL units) and the extended function registers An (for SLPC and SLMC only).

5-11. Preparation for Operation.

5-11-1. Connecting Power Source Plug.

A 3-pole power plug is used, but a 3-pole-to-2-pole adapter is supplied to enable connection to a 2-pole socket. The grounding wire should always be properly grounded.

5-11-2. Connecting Programmable Instrument.

With the power supplies OFF, connect the programmer flat cable to the programmable instrument. For more information, see Section 3-2.

5-11-3. Connecting Printer.

To use the printer, disconnect the power supplies and connect the printer to the socket on the left side of the programmer (see Figure 3-2-5).

5-12. Keying in Program.

5-12-1. Preparation.

Before applying power to the programmer, set the TEST RUN/PROGRAM toggle switch to PROGRAM mode. Apply power, and let the programmer warm up for a while. The initial programmer display is as shown below.

(Programmer display)

MAIN PROGRAM

Program generation procedures are dependent upon the types of programmable instruments. Necessary items for each instrument are described below.

Program Generation Procedures	Instruments							
	SLPC*E	SLPC*A	SLMC*E	SLMC*A	SCMS	SPLR	5 ₃ 47	5 ₃ 55
Initialize Programmer	INZ	○	○	○	○	○	○	○
Initialize Parameters	INIP	○	○	○	○	○	—	—
Generate Main Program	MPR	○	○	○	○	○	○	○
Generate Subprogram	SBP	○	—	○	—	○	—	—
Generate Simulation Program	SPR	○	○	○	○	○	—	—
Set DIO Terminals	DIO	○	—	○	—	○	—	—
Set Constants (Kn)		○	○	○	○	○	○	○
Set Control Elements (CNTn)		○	○	○	○	○	—	—
Generate Display Table (Xn,Pn,Yn)		○	○	○	○	○	—	—
Set ID Number		○	○	○	○	○	○	○

5-12-2. Initializing Programmer.

The programmer should be initialized before generating programs.

Key operation	Programmer display
(1) F } = INZ	MAIN PROGRAM
(2) [] }	m 1
	INIT PROGRAM
(3) G } = INIP	MAIN PROGRAM
(4) [] }	m 1
	INIT PARAMETER
	MAIN PROGRAM

The **INZ** key is used to initialize the program area, constants and display table, and the **INIP** key initializes the SLPC tuning parameters.

5-12-3. Keying in Main Program.

After initializing the programmer, key in the main program step-by-step. The correspondence between instruction codes and programmer displays is shown in Table 5-8-1.

5-12-4. Keying in Subprograms.

SLPC*E and SCMS can use subroutines which can be executed at several times. Thirty types of subroutines can be created in 99-step subprogram areas.

For functions with device addresses (except FX), the same device address number should not be executed in a routine.

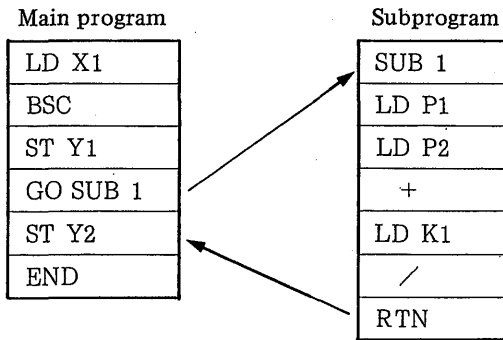

Key operation	Programmer display
01 LD X 1	MAIN PROGRAM
02 BSC	m 1 LD X 1
03 ST Y 1	m 2 BSC
04 GO SUB 0 1	m 3 ST Y 1
05 ST Y 2	m 4 GO SUB 1 e
06 END	m 5 ST Y 2
SBP	m 6 END
	SUB PROGRAM
01 SUB 1	s b 1 SUB 1 e
02 LD P 0 1	s b 2 LD P 1
03 LD P 0 2	s b 3 LD P 2
04 +	s b 4 +
05 LD K 0 1	s b 5 LD K 1
06 /	s b 6 /
07 RTN	s b 7 RTN e

where

m: Main program

sb: Subprogram

si: Simulation program (see Section 5-12-5)

e: Style E program

5-12-5. Keying in Simulation Program.

For the SLPC, SLMC and SCMS, a simple process simulation can be programmed in SPRG program area. The simulation program shares 20 steps and allows a closed loop off-line test run. In this program area, the user can program a process simulation in the same procedures as for the main program. The total number of general functions with device addresses (LEDn, LAGn, DEDn, etc.) used in the simulation and main programs should be within the limits specified.

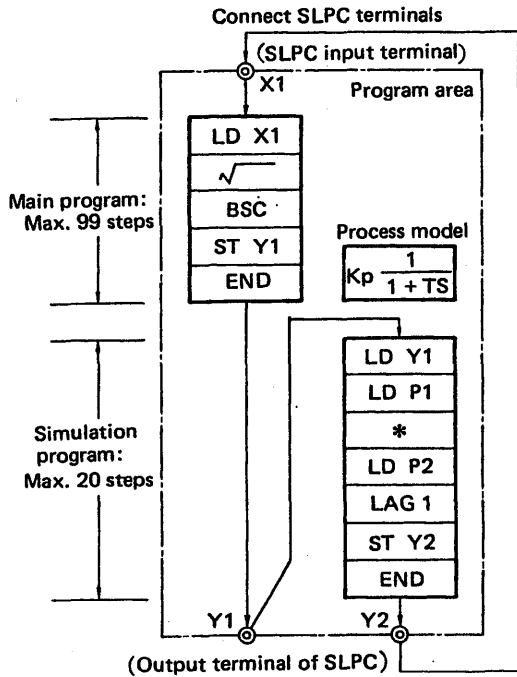

Figure 5-12-1. Simulation Program.

The main program and simulation program shown in Figure 5-12-1 are keyed in as follows:

Key operation	Display
01 LD X 1	MAIN PROGRAM
02 $\sqrt{\quad}$	m 1 LD X 1
03 BSC	m 2 SQT
04 ST Y 1	m 3 BSC
05 END	m 4 ST Y 1
	m 5 END
SPR	SIMUL PROGRAM
01 LD Y 1	Si 1 LD Y 1
02 LD P 0 1	Si 2 LD P 1
03 *	Si 3 *
04 LD P 0 2	Si 4 LD P 2
05 LAG 1	Si 5 LAG 1
06 ST Y 2	Si 6 ST Y 2
07 END	Si 7 END

5-12-6. Keying in DIOs (digital I/O) (for SLPC*E, SLMC*E and SCMS).

- (1) DIO DIO >>
- (2) 0 DIO O>
- (3) 1 DIO 1
- (4) m (m = 0, 1) DIO 1 m
- (5) ENT DIO 1 m

SLPC*E can set DIOs 1 through 6, SLMC*E DIOs 1 through 4 and SCMS DIOs 1 through 10. When the INZ (initialize) key is pressed, DIOs 1 through 3 (for the SLPC*E) and DIOs 1 through 5 (for the SCMS) are set for status input; DIOs 4 through 6 (for the SLPC*E) and DIOs 6 through 10 (for the SCMS) are set for status output.

5-12-7. Keying in Constants.

1. Displaying constants.

- (1) K K
- (2) 0 or 1 Km
- (3) 0 to 9 } 01 to 16 Kmn 0.000

When the function FX is used, specify constants K20 to K85 for SCMS and K20 to K41 for SPLR, 5255 and 5355.

2. Keying in numeric values.

Numeric values -7.999 to 7.999 can be input using the numeric keys. For a negative value, press the (S) key prior to keying in the numeric value. The example shows how to key in "-4.507".

- (1) (S) Kmn -
- (2) 4 Kmn -4
- (3) . Kmn -4.
- (4) 5 Kmn -4.5
- (5) 0 Kmn -4.50
- (6) 7 Kmn -4.507

3. ENT

After keying in the numeric value, press the ENT key to store it.

5-12-8. Designating Control Functions.

For the SLPC, SLMC and SCMS, control function module designations need to be entered.

- (1) CNT CNT>
- (2) 1 CNT 1
- (3) m (m = 1 ~ 3) CNT 1 m
- (4) ENT CNT 1 m
- (5) CNT CNT>
- (6) 2 CNT 2
- (7) n (n = 1 ~ 3) CNT 2 n
- (8) ENT CNT 2 n

The example shown in steps (5) through (8) applies to cascade or selector control. CNT3 may also be specified for selector control.

Keying in CNT4 and 5.

- (1) **CNT** CNT>
- (2) **4** CNT 4
- (3) m CNT 4 m
- (4) **ENT** CNT 4 m
- (5) **CNT** CNT>
- (6) **5** CNT 5
- (7) n CNT 5 n
- (8) **ENT** CNT 5 n

When the **ENT** key is pressed, the display is turned off and on, and the designation is completed.

5-12-9. Designating Display Table (SLPC, SLMC, SCMS and IPL).

1. Displaying inputs (registers Xn).

- (1) **X** X>
- (2) **n** Xn H 100.0
- (3) A 4-digit number is keyed in. For example, if it is 120.0:

1 2 0 . 0 Xn H 120.0

- (4) **ENT** Xn H 120.0

After keying in numeric values, press the **ENT** key to store the numeric value in the programmer.

- (5) **ENT** Xn L 000.0

Each time the **ENT** key is pressed without keying in a numeric value, the display alternates between XnH and XnL (high and low limits of range).

- (6) Follow the procedure shown in (3) and (4) for keying in numeric values. For example, when 0% = -40.0 is keyed in, the decimal point position (see below) must be the same as it would be when entering the value corresponding to 100%.

(S) 0 4 0 . 0 Xn L -040.0

ENT Xn L -040.0

2. Displaying outputs (registers Yn).

The procedure is the same as that of 1. above, except that the **Y** key is operated instead of the **X** key.

3. Displaying parameters.

The procedure is the same as for 1. above, except that the **P** key is operated instead of the **X** key.

5-12-10. Setting ROM ID Number.

To set ROM ID number to 4662:

- (1) **ID** SLPC 0000
- (2) **4 6 6 2** SLPC 4662
- (3) **ENT** SLPC 4662

The instrument model, for example, SLPC (including SLPC*E and SLPC*A) is displayed automatically.

5-13. Modifying Program.

5-13-1. Deleting Incorrect Key Entry.

1. Deleting incomplete program step.

To delete incomplete program step (on the way of one line), press the **CAN** (cancel) key. When the **CAN** key is pressed, the display returns to the previous program step. When the **CAN** key is pressed, the display indicates the previous step. To delete an instruction which has been completely entered, use the **DEL** key.

Deleting a program step using the **CAN** key.

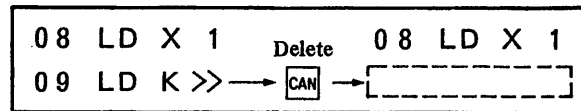

Deleting a program step using the **DEL** key.

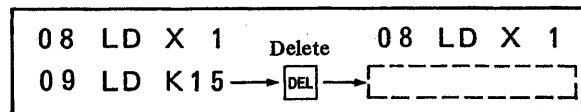

2. Deleting entries for constants Kn and temporary storage registers Tn.

- (1) Numeric values entered in Kn and Tn can be cleared by pressing the **CAN** key before pressing the **ENT** key.

- (2) To change a numeric value already stored in Kn or Tn, display the old value, enter a new numeric value and press the **ENT** key. This replaces the old value with a new one.

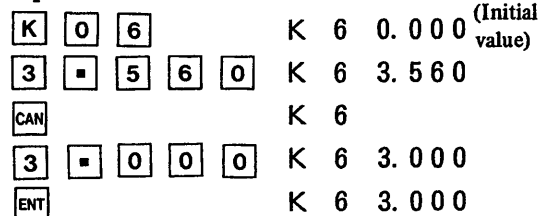

K	0	6				K 6 0.000	(Initial value)
3	▣	5	6	0		K 6 3.560	
ENT						K 6 3.560	
3	▣	0	0	0		K 6 3.000	
ENT						K 6 3.000	

- If you make an error when entering the display table of SLPC, SLMC, SCMS or IPL Station, follow the same procedure as shown in 2 above to make the necessary changes.
- To change the SLPC, SLMC or SCMS control function designation, follow the same procedure as shown in 2 above.

5-13-2. Deleting Program Step.

In the following program, to delete step 05: LD K02, proceed as follows:

- Display the step to be deleted using the numeric keys (Press keys 0 and 5). The step may also be displayed by stepping through the program using ▲ and ▼ keys.
- Press the DEL key to delete the step. The display will then show the previous step.

Before deletion		After deletion	
m 1	LD X 2	m 1	LD X 2
m 2	LD K 1	m 2	LD K 1
m 3	*	m 3	*
m 4	LD X 3	m 4	LD X 3
Display this step	m 5 LD K 2	m 5	+
	m 6 +	m 6	ST Y 2
	m 7 ST Y 2	m 7	GO 19
	m 8 GO 20	m 8

Annotations: Arrows point from the 'Display this step' box to the 'm 5 LD K 2' row and from the 'Displays previous step after deletion' box to the 'm 4 LD X 3' row.

All steps following the deleted step move one step in memory.

- Finally, operate the ▲ and ▼ keys to confirm that the incorrect step has been deleted.

5-13-3. Inserting Program Step.

In the following program, the following procedure inserts the step ST T1 between steps 04 and 05:

- Display the step preceding the one to be inserted (step 04 in this case).
- To insert the new step, follow the same key operation procedure as for keying in an ordinary program. In this case, the keys ST, T and 1 are pressed.

Before modification		After insertion	
m 1	LD X 2	m 1	LD X 2
m 2	LD K 1	m 2	LD K 1
m 3	*	m 3	*
Display previous step	m 4 LD X 3	m 4	LD X 3
	m 5 +	m 5	ST T 1
	m 6 ST Y 2	m 6	+
	m 7 GIF 30	m 7	ST Y 2
	m 8	m 8	GIF 31

Annotations: Arrows point from the 'Displays previous step after insertion' box to the 'm 5 ST T 1' row and from the 'm 5 +', 'm 6 ST Y 2', and 'm 7 GIF 30' rows to the 'm 6 +', 'm 7 ST Y 2', and 'm 8 GIF 31' rows respectively.

Program steps following the inserted step will be shifted by one step.

- Finally, operate ▲ and ▼ keys to confirm that the desired program step insertion has been performed.

5-13-4. Jump Instruction Target Address Changes Automatically.

After deletion or insertion of a program step, the target address of jump instructions (GO GIF) changes automatically.

Before modification		After modification	
m 9	GO 30	m 9	GO 29
:	:	:	:
Deletion	m 17 LD K 5	:	:
:	:	m 29	LD X 3
m 30	LD X 3		

Annotation: An arrow points from the 'm 30 LD X 3' row to the 'm 29 LD X 3' row.

If the deletion or addition does not affect the jump instruction, there is no change of target address.

Before modification	After modification
m 9 GIF 30 →	m 9 GIF 30
⋮	⋮
m 30 LD X 3 →	m 30 LD X 3
	m 31 LD K 5 Addition

If the instruction which is the target of a jump instruction is deleted, the target address in the jump instruction is not be changed.

Modify the target step number in the jump instruction as necessary.

Before modification	After modification
m 9 GIF 30 →	m 9 GIF 30
⋮	⋮
m 30 LD X 3 Deletion	m 30 LD K 5
m 31 LD K 5	

5-14. Test Run.

5-14-1. Test Run.

1. After completely keying in the program, step through it to confirm that all program steps are correct.

- (1) Press the MPR key to MAIN PROGRAM select program mode.

m 1 LD X 1
m 2 LD K 1
⋮
m n END
- (2) Press the ▲ key to display the next program step, and check that it is correct.

For the SLPC, SLMC and SCMS press the SBP or SPR key to select the subprogram or the simulation program and step through it to confirm that it is correct.

- (3) Check the constants. For example, for K01, press keys K 0 1 to display the value of K01.

K 1 □□□□

- (4) For SLPC, SLMC, SCMS and IPL Station, the display table must be checked.

The procedure is similar to that for constants. Pressing X 1 displays the 100% value for the range of X1 in engineering units, pressing ENT displays the 0% value.

X 1 H □□□□
X 1 L □□□□

2. Set the TEST RUN/PROGRAM switch to the TEST RUN position.

TEST RUN

3. A test run is initiated by pressing the RUN key.
4. Apply voltages of 1 to 5 V DC to each input terminal with the programmer connected, and check that the input-output relationship is as intended.
5. If any problems are detected during the test run, set the TEST RUN/PROGRAM switch to the PROGRAM mode position, and correct the program according to the procedure described in Section 5-13. After correcting the program, set the switch back to the TEST RUN position, and press the RUN key to repeat the test run.

5-14-2. Load Rate of Program.

The program load rate is displayed only when the Programmer is connected to SLPC*E, SLMC*E or SCMS*E.

1. If the CAN key is pressed while the test run is being executed, the current load rate flashes at the right of the programmer display.

$$\text{Load rate} = \frac{\text{Program execution time}}{\text{Computing time}} \times 100\%$$

TEST RUN 50%
(flashing)

2. The rate of program load, when the test run is executed, must be less than 100% in any program path. If it exceeds 100%, "OVER" flashes. Leave the rate of program load less than 100%.

Note: Under operating status, the program execution time 20 ms is added for key operation and communication processing.

5-14-3. Displaying and Modifying Register Data.

In test run mode, each register can be displayed, and it is possible to not only display its value on the programmer but also to change its value.

1. Registers Xn.

 X n .

The input data display ranges from 0.0 to 1.0 corresponding to the input data 1 to 5 V DC. However, when the program uses an ST Xn instruction, the input data display may range from -7.999 to +7.999.

2. Registers Yn.

 Y n .

The output signal of 1 to 5 V DC (or 4 to 20 mA DC) is displayed for the input data ranging from 0.0 to 1.0. Data ranging from -7.999 to +7.999 can be stored and displayed by Yn registers. For the SLPC and SLMC, data Y4, Y5 and Y6 to be transmitted to a supervisory system can be checked.

3. Registers Pmn (not in Model 5₃55).

 Pmn .

The set values of parameters are displayed as data in range 0.0 to 1.0 (for SLPC, SLMC and SCMS, values are -7.999 to +7.999, and the setting can be changed from the instrument side-panel keyboard as well as from the programmer).

4. Registers Tmn.

 Tmn .

The values of temporary storage registers are displayed as data of range -7.999 to +7.999. Setting change is possible.

5. Registers Kmn.

 Kmn .

The keyed-in values are displayed. Setting change is possible. For SPLR, SCMS and Model 5₃55, it is possible not only to display but also to set K20 to K85 (for SCMS), K20 to K41 (for SPLR) and K20 to K40 (for 5₃55), the constants which define line segment functions.

6. Registers Amn (for SLPC and SLMC).

 Amn .

The extended function register values are displayed as data in the range 0.0 to 1.0 (or data of range -7.999 to +7.999, depending on the signal).

7. Registers Dimn (not in Model 5₃55).

 DImn

0 indicates the OPEN contact condition, 1 indicates the CLOSED contact condition.

8. Registers DOMn (not in Model 5₃55).

 DOmn

The contact output signal status is displayed, the same as for contact input signals.

9. Registers FLmn (SLPC, SLMC, SCMS, SPLR, Model 5₃55).

 FLmn

For the registers with extension functions, the values are displayed as integer data of range between 0 and 1. For SPLR and Model 5₃55, the result of self-diagnosis will be displayed.

10. Registers Emn (SLPC*E, SLMC*E and SCMS).

 Emn .

For SLPC*E and SLMC*E, data to be sent to the SCMS is displayed. For SCMS, data ranging from -7.999 to +7.999, which is sent from the SLPC*E and SLMC*E is displayed.

11. Registers Dmn (SLPC*E, SLMC*E and SCMS).

 Dmn .

For SLPC*E and SLMC*E, data to be sent to the SCMS is displayed. For SCMS, data ranging from -7.999 to +7.999, which is sent to the SLPC*E and SLMC*E is displayed.

12. Registers CImn (SLPC*E, SLMC*E and SCMS).

 CImn

Same as register E. Data 0 and 1 are displayed.

13. Registers COMn (SLPC*E, SLMC*E and SCMS).

 COMn

Same as register D. Data 0 and 1 are displayed.

14. Registers KYn (SLPC*E and SCMS).

 KYn

The front panel switch statuses are stored. Switch ON-status is displayed by "1"; switch OFF-status by "0".

15. Registers LPn (SLPC*E, SLMC*E and SCMS).

 LPn

The front panel lamp statuses are stored. Lamp ON-status is displayed by "1" and lamp OFF-status by "0".

16. Registers Bmn cannot be displayed contents of register. Check registers Bmn on the side panel of the programmable controller.

5-14-4. Change of Parameters (SLPC, SLMC and SCMS).

In test run mode, the parameters can be changed using the tuning panels on the front and side of SLPC, SLMC or SCMS. When the program is stored in ROM, the final parameter settings are stored as initial values.

5-15. Storing a Program in ROM.

5-15-1. Storing Program.

After verifying the program by a test run, store it into ROM.

- (1) Install a blank ROM in the ROM socket of the programmer (observe correct orientation of ROM in socket – note notch orientation).

Note: ROM may be damaged or deteriorated when ROM is installed in the upper and lower opposite direction.

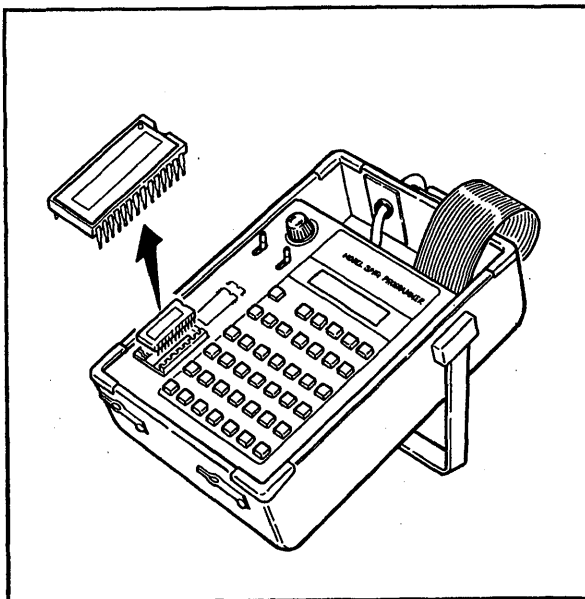

Figure 5-15-1. Orientation of ROM.

- (2) When the **WR** key is pressed, "ROM WRITE" display flickers. The display changes to "COMPLETE" within about 100 seconds, after data storage has been completed.

ROM WRITE
COMPLETE

- (3) When data storage is not possible, the SPRG displays one of the following messages:

NOT BLANK

NOT BLANK – which means that the ROM is not blank. Remove the ROM from the socket and erase it in the procedures described in Section 5-16-2. Or the ROM may not be connected to the socket correctly.

R/W ERROR

This indication means that data has been stored into the ROM, but the data stored in the programmer and the data stored in (and read back from) the ROM differ.

- (4) After completing storing data into the ROM, stick the opaque seal over the window of the ROM.

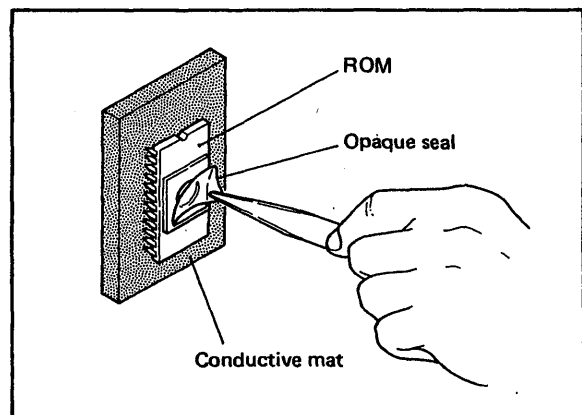

Figure 5-15-2. Attaching Opaque Seal.

- (5) When the ROM loaded with data is plugged into the ROM socket of the programmable instrument, the instrument operates according to the program.

[CAUTION]

If the program – created by the SPRG that is combined with the SLPC*E and SLMC*E – is stored into ROM with function "Style E" (see below), it cannot be used for SLPC*A and SLMC*A (if it is used, the ROM fails).

Function "Style E" includes:

- (1) "e" is displayed at the right of the display when a program is created.
- (2) CNT4 or CNT5 set to other than 0.
- (3) DIO changed from initial status (for example, set other than DIO1 through DIO3 = 0, DIO4 through DIO6 = 1, in case SLPC*E).
- (4) A new program created in a subprogram area.

5-16. Reading or Erasing ROM Program.

5-16-1. Reading ROM Contents.

The ROM contents can be transferred to — and displayed on — the programmer. When the transfer instruction is executed, the program previously stored in the programmer is deleted.

1. Reading the ROM plugged into the socket of the programmer:

RD ROM READ COMPLETE

The **ID** key is used to check the ID number, and the **▲** key for checking each step of the program. If the **RD** key is pressed with no ROM installed, the following indication will appear.

ROM ERROR

If a different ROM is installed and called by pressing the **RD** key, the following display appears.

ERROR ROM
 ↑ Instrument Model for the ROM

If the ROM is blank, "BLANK ROM" is displayed.

2. The **XFR** key is used to check the contents of the ROM installed in the instrument.

TRANSFER COMPLETE

The **ID** key is used to check the ID number, and the **▲** key is used to check each step of the program.

If the **XFR** key is pressed without installing ROM, "TRANSFER ERROR" is displayed.

TRANSFER ERROR

5-16-2. Erasing ROM Contents.

To erase the ROM contents, use a commercially-available ultraviolet erasing device. When using such a device, remove the opaque seal from the window of the ROM.

5-17. Printout.

Programs or data can be printed out by connecting a printer to the SPRG and manipulating the appropriate printer control key.

A special cable (see Figure 5-17-1) supplied by Yokogawa Electric Corporation is necessary for connecting the printer.

Figure 5-17-1 shows the interconnection diagram.

Refer to Section 5-10 for the key definitions.

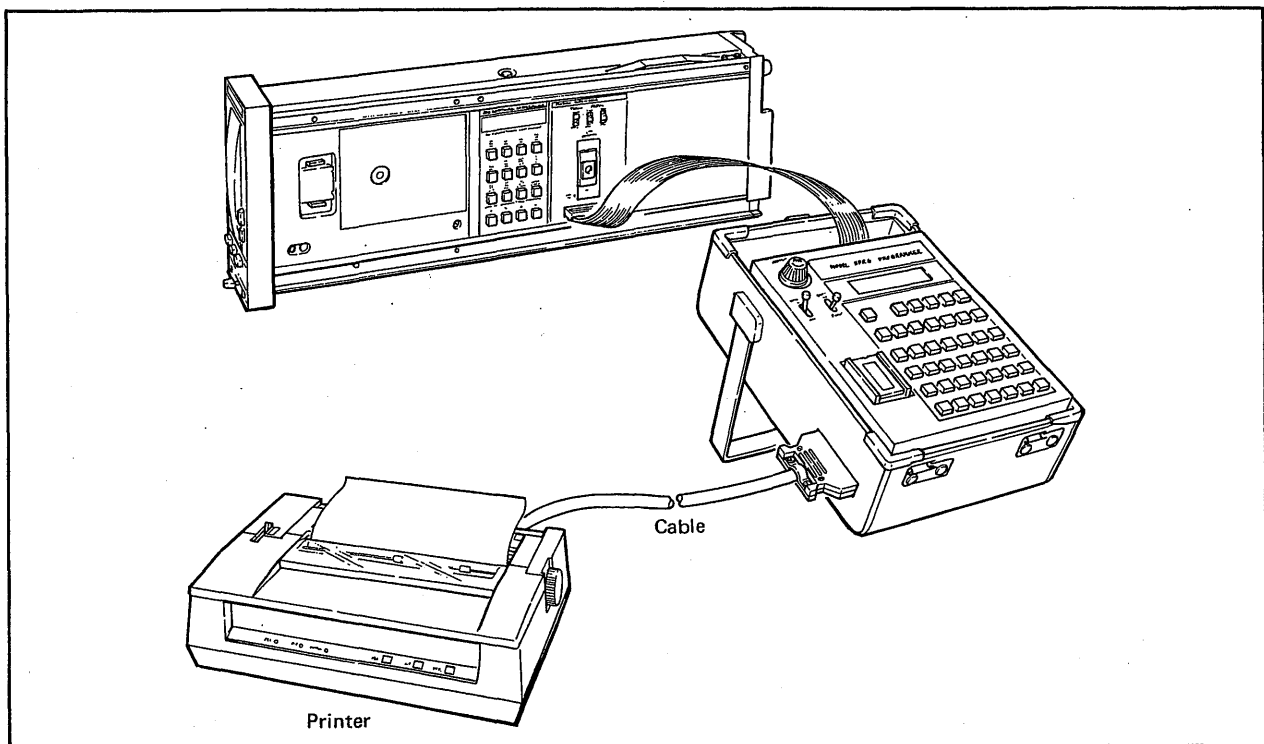

Figure 5-17-1. Connecting Printer.

5-17-1. Printing a Program List.

A program list can be printed out on the printer by using the **LIST** key in program mode.

To print out a main program list, press **MPR** and **LIST**. To print out a subprogram list, press **SBP** and **LIST**.

To print out a simulation program list, press **SPR** and **LIST**.

A printout example is shown in Figure 5-17-2.

5-17-2. Printing Parameters.

In program mode, the **PMT** (parameter) key is used to printout input signal Xn, output signal Yn, parameter Pn, and constant Kn. When the SLPC or SLMC is connected, the control function data including PID parameters is also printed out.

To print out parameters, press **PMT**.

The printout is produced in three pages like the sample printout which is shown in Figure 5-17-3.

5-17-3. Printing Data.

In test run mode, it is possible to print out momentarily-changing data, such as input signal Xn, output signal Yn, temporary register Tn, computational parameter Pn (excluding IPL unit), and function extension register An (SLPC and SLMC).

(Register content printout operation).

- (1) **REG**
- (2) **X** **1** **ENT** to print data X1.
- (3) **Y** **2** **ENT** to print data Y2.
- (4) **ENT** to print data Y2 which is written at the time **ENT** is pressed.
- (5) **CAN** to cancel **REG** key instruction.

In the above key-in sequence, **REG** is set in program mode and step (2) through (5) is executed in test run mode.

A sample printout is shown in Figure 5-17-4.

Note: The printout examples presented in Figures 5-17-2 to 5-17-4 are A4 sized each.

SLPC	USER	PROGRAM	ROM ID: 4662	DATE	/ /
STEP	PROGRAM	COMMENT	STEP	PROGRAM	COMMENT
1	LD	FL10	51		
2	GIF	8	52		
3	LD	K 3	53		
4	ST	A 1	54		
5	LD	K 2	55		
6	TIM	1	56		
7	GO	26	57		
8	LD	K 1	58		
9	TIM	1	59		
10	LD	K 8	60		
11	*		61		
12	ST	Y 4	62		
13	ST	P 1	63		
14	LD	K 1	64		
15	CMP		65		
16	GIF	21	66		
17	LD	Y 4	67		
18	FX	1	68		
19	ST	A 1	69		
20	GO	26	70		
21	LD	K 2	71		
22	ST	FL10	72		
23	LD	K 2	73		
24	ST	Y 4	74		
25	ST	P 1	75		
26	LD	X 1	76		
27	BSC		77		
28	ST	Y 1	78		
29	END		79		
30			80		
31			81		
32			82		
33			83		
34			84		
35			85		
36			86		
37			87		
38			88		
39			89		
40			90		
41			91		
42			92		
43			93		
44			94		
45			95		
46			96		
47			97		
48			98		
49			99		
50					

TAG NO. 1
INSTRUMENT NO. 1

Figure 5-17-2. Printout Example of a Program List.

SLPC	TUNING	PARAMETER	ROM ID: 0000	DATE	/ /
MODE 1	0	: COLD START			
MODE 2	0	: CASCADE OFF			
MODE 3	0	: CSV2 CLOSE			
MODE 4	0	: BACKUP M=N			
MODE 5	0	: WRITE ENABLE			
FB 1	999.9 %		FE 2	999.9 %	
TI 1	1000 SEC		TI 2	1000 SEC	
TO 1	0 SEC		TO 2	0 SEC	
BD 1	0.0 %		BD 2	0.0 %	
BB 1	0.0 %		BE 2	0.0 %	
BL 1	0.0 %		BL 2	0.0 %	
ST 1	0 SEC		ST 2	0 SEC	
SW 1	0 SEC		SM 2	0 SEC	
GW 1	0.0 %		GM 2	0.0 %	
GB 1	100.0 %		GB 2	100.0 %	
DL 1	100.0 %		DL 2	100.0 %	
VL 1	100.0 %		VL 2	100.0 %	
VT 1	1 SEC		VT 2	1 SEC	
PH 1	106.3 %		PH 2	106.3 %	
PL 1	-6.3 %		PL 2	-6.3 %	
HM 1	106.3 %		HM 2	106.3 %	
ML 1	-6.3 %		ML 2	-6.3 %	
HI 1	100.0		HI 2	100.0	
LO 1	0.0		LO 2	0.0	
P 1	0.000		P 9	0.000	
P 2	0.000		P10	0.000	
P 3	0.000		P11	0.000	
P 4	0.000		P12	0.000	
P 5	0.000		P13	0.000	
P 6	0.000		P14	0.000	
P 7	0.000		P15	0.000	
P 8	0.000		P16	0.000	
PX1	-0.000		PX2	-0.000	
PY1	-0.000		PY2	-0.000	
PZ1	-0.000		PZ2	-0.000	

TAG NO.:

INSTRUMENT NO.:

SLPC	TUNING	PARAMETER	ROM ID: 0000	DATE	/ /
P20	0 SEC		P30	0.0 %	
P21	0 SEC		P31	0.0 %	
P22	0 SEC		P32	0.0 %	
P23	0 SEC		P33	0.0 %	
P24	0 SEC		P34	0.0 %	
P25	0 SEC		P35	0.0 %	
P26	0 SEC		P36	0.0 %	
P27	0 SEC		P37	0.0 %	
P28	0 SEC		P38	0.0 %	
P29	0 SEC		P39	0.0 %	
FX 1	0.0 %		GX 1	0.0 %	
FX 2	10.0 %		GX 2	10.0 %	
FX 3	20.0 %		GX 3	20.0 %	
FX 4	30.0 %		GX 4	30.0 %	
FX 5	40.0 %		GX 5	40.0 %	
FX 6	50.0 %		GX 6	50.0 %	
FX 7	60.0 %		GX 7	60.0 %	
FX 8	70.0 %		GX 8	70.0 %	
FX 9	80.0 %		GX 9	80.0 %	
FX10	90.0 %		GX10	90.0 %	
FX11	100.0 %		GX11	100.0 %	
H 1	0.0 %		I 1	0.0 %	
H 2	10.0 %		I 2	10.0 %	
H 3	20.0 %		I 3	20.0 %	
H 4	30.0 %		I 4	30.0 %	
H 5	40.0 %		I 5	40.0 %	
H 6	50.0 %		I 6	50.0 %	
H 7	60.0 %		I 7	60.0 %	
H 8	70.0 %		I 8	70.0 %	
H 9	80.0 %		I 9	80.0 %	
H10	90.0 %		I10	90.0 %	
H11	100.0 %		I11	100.0 %	
L 1	0.0 %		M 1	0.0 %	
L 2	10.0 %		M 2	10.0 %	
L 3	20.0 %		M 3	20.0 %	
L 4	30.0 %		M 4	30.0 %	
L 5	40.0 %		M 5	40.0 %	
L 6	50.0 %		M 6	50.0 %	
L 7	60.0 %		M 7	60.0 %	
L 8	70.0 %		M 8	70.0 %	
L 9	80.0 %		M 9	80.0 %	
L10	90.0 %		M10	90.0 %	
L11	100.0 %		M11	100.0 %	

TAG NO.:

INSTRUMENT NO.:

SLPC	SCALE DATA & CONSTANT	ROM ID: 0000	DATE	/ /
X1H	100.0	X1L	000.0	
X2H	100.0	X2L	000.0	
X3H	100.0	X3L	000.0	
X4H	100.0	X4L	000.0	
X5H	100.0	X5L	000.0	
Y1H	-0001	Y1L	-0001	
Y2H	-0001	Y2L	-0001	
Y3H	-0001	Y3L	-0001	
Y4H	-0001	Y4L	-0001	
Y5H	-0001	Y5L	-0001	
Y6H	-0001	Y6L	-0001	
P1H	100.0	P1L	000.0	
P2H	100.0	P2L	000.0	
P3H	100.0	P3L	000.0	
P4H	100.0	P4L	000.0	
P5H	100.0	P5L	000.0	
P6H	100.0	P6L	000.0	
P7H	100.0	P7L	000.0	
P8H	100.0	P8L	000.0	
K 1	0.000	K 9	0.000	
K 2	0.000	K10	0.000	
K 3	0.000	K11	0.000	
K 4	0.000	K12	0.000	
K 5	0.000	K13	0.000	
K 6	0.000	K14	0.000	
K 7	0.000	K15	0.000	
K 8	0.000	K16	0.000	
CNT 1	1	: BASIC CONTROL		
CNT 2	1	: BASIC CONTROL		
CNT 3	0	: LGM SELECTOR		
CNT 4	0	: 200 ms CYCLE		
CNT 5	0	: AUT Mn CONTROL		
D10 1	0	: IN		
D10 2	0	: IN		
D10 3	0	: IN		
D10 4	1	: OUT		
D10 5	1	: OUT		
D10 6	1	: OUT		

TAG NO.:

INSTRUMENT NO.:

Figure 5-17-3. Printout Example of Parameters.

REGISTER DATA	VALUE
A01	0.500
A02	0.000
A03	1.000
A04	0.000
A09	-8.000
A12	0.503
FL01	0
FL02	0
FL03	0
FL04	0
FL09	0
FL10	0
FL11	1
X 1	0.503
P01	0.200
Y 1	0.503
Y 4	0.200

Figure 5-17-4. Data Printout Example.

6. MAINTENANCE.

6-1. Changing Fuse.

To remove the fuse, unscrew the fuse holder cap in the direction of the arrow mark. To install a new fuse, insert it into the cap, then screw it into the fuse holder.

Fuse part No.: S9510VK.

Rating: 1 A.

Note: Use the dedicated fuse (S9510VK). Do not use a fuse for other products.

6-2. Precautions in Handling User ROM.

User ROM is a EPROM – a MOS (metal oxide semiconductor) IC. This type of IC must be handled carefully, as it may be damaged by static electricity. Note also that the program written into it will be lost if ultraviolet rays are applied through the window of this IC.

Observe the following cautions when handling the ROM:

○ **Cautions against static electricity:**

Be sure to use a conductive mat when carrying and storing this element. Do not bring the EPROM into contact with clothes and other substances that can be charged easily. Do not handle the EPROM using chemical fiber gloves.

○ **Cautions against ultraviolet rays:**

Do not remove the seal of EPROM except when erasing the contents.

When attaching a new EPROM to the controller, be sure to affix the specified seal to the EPROM.

○ **Caution not to deform pins:**

If the pins are deformed, straighten them, taking care not to apply force to the root of each pin.

○ **Caution about installation direction**

EPROM may be damaged or deteriorated when EPROM is installed in the upper and lower opposite direction. In this case, make a new EPROM.

7. TROUBLESHOOTING.

If a problem occurs in the Model SPRG Programmer, identify the problem and resolve it according to the troubleshooting flowcharts shown in Section 7-1.

If the problem is difficult to find, consult your nearest YOKOGAWA service station or sales representative.

7-1. Troubleshooting Flowcharts.

[1] Problem identification

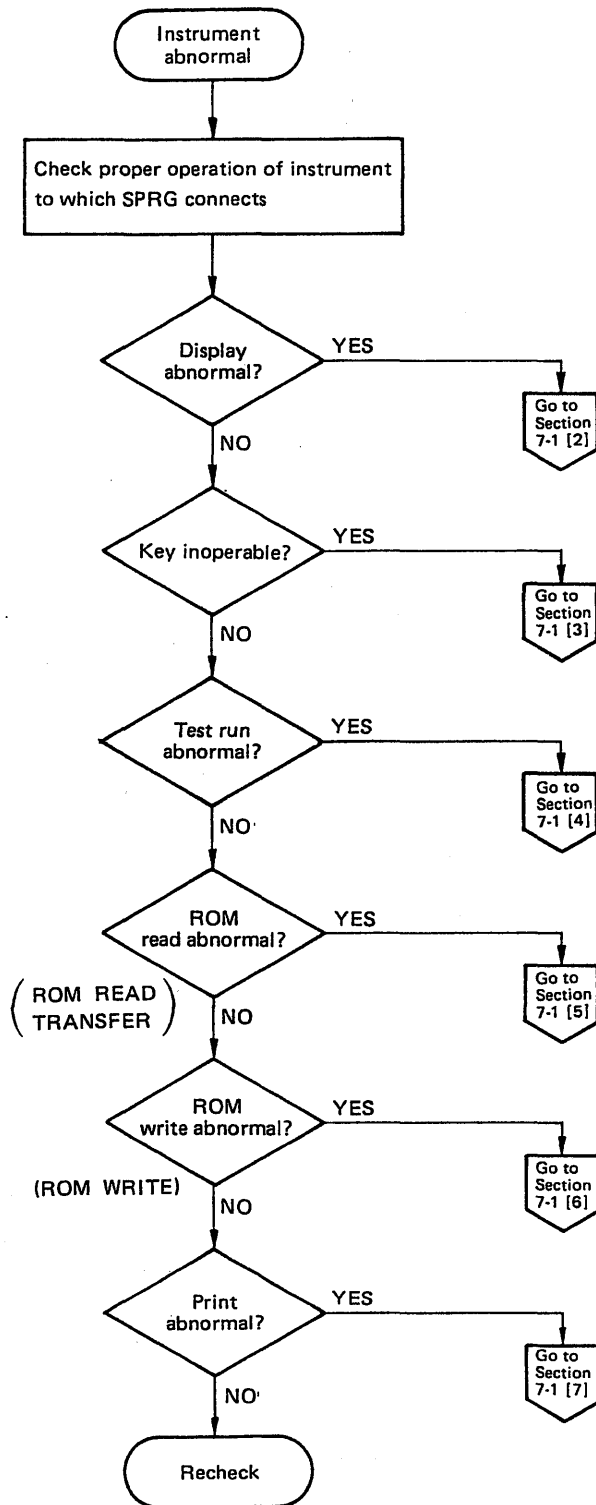

[2] Display abnormal

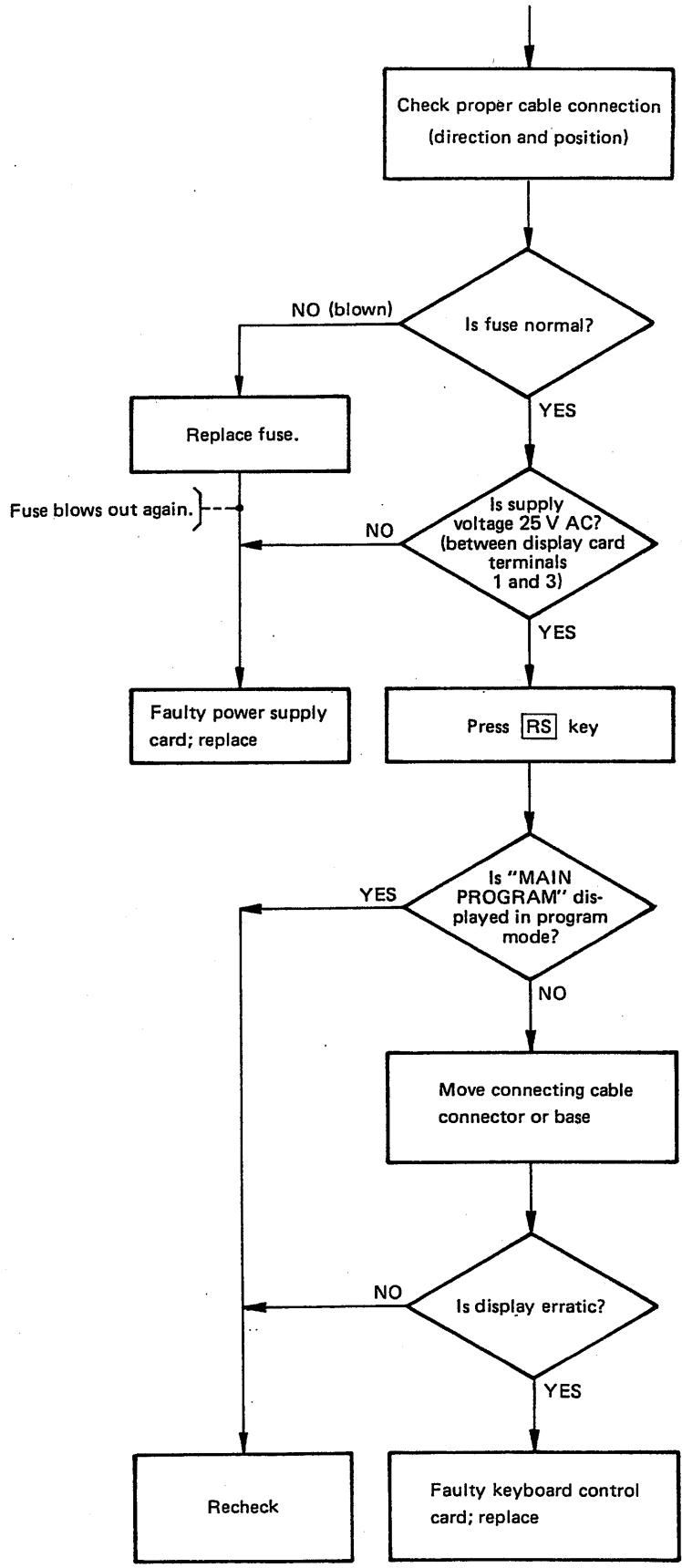

[3] Key inoperable

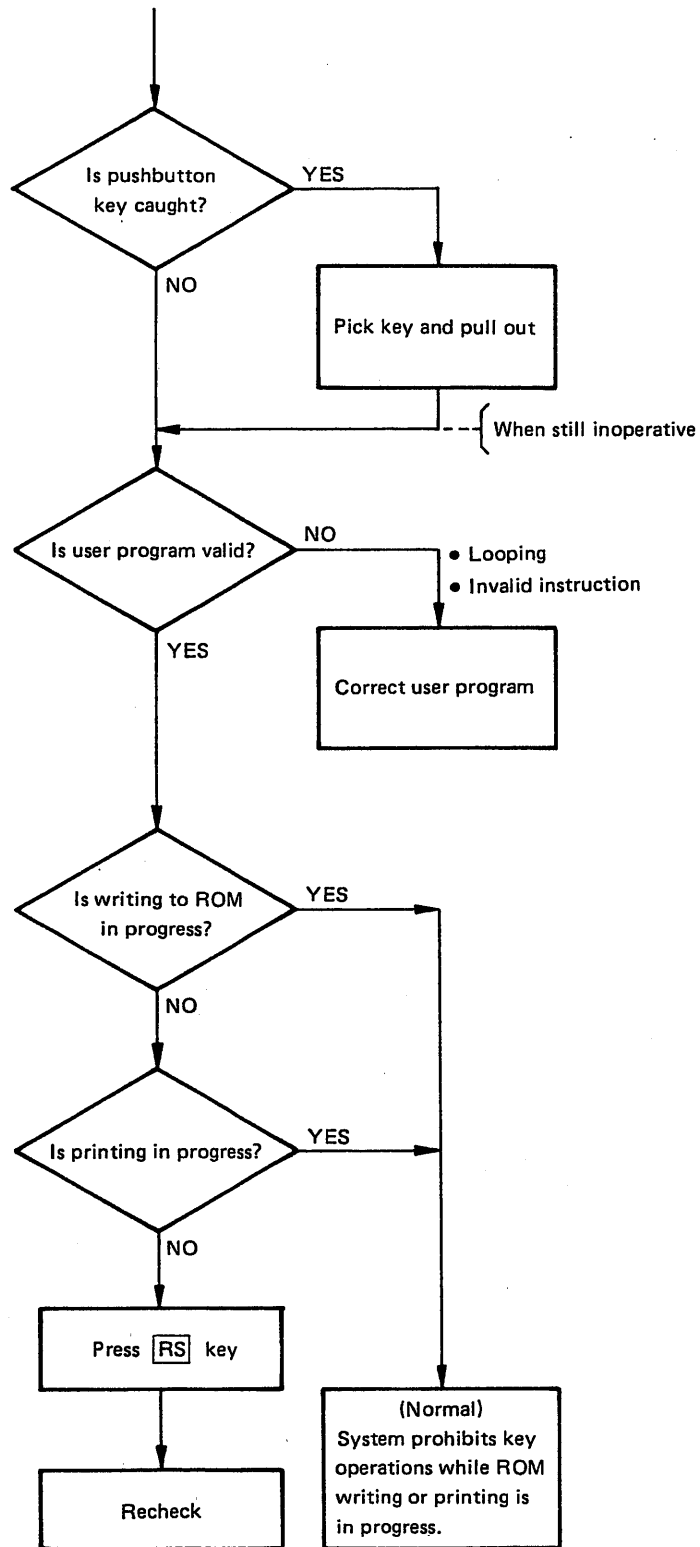

[4] Test run abnormal

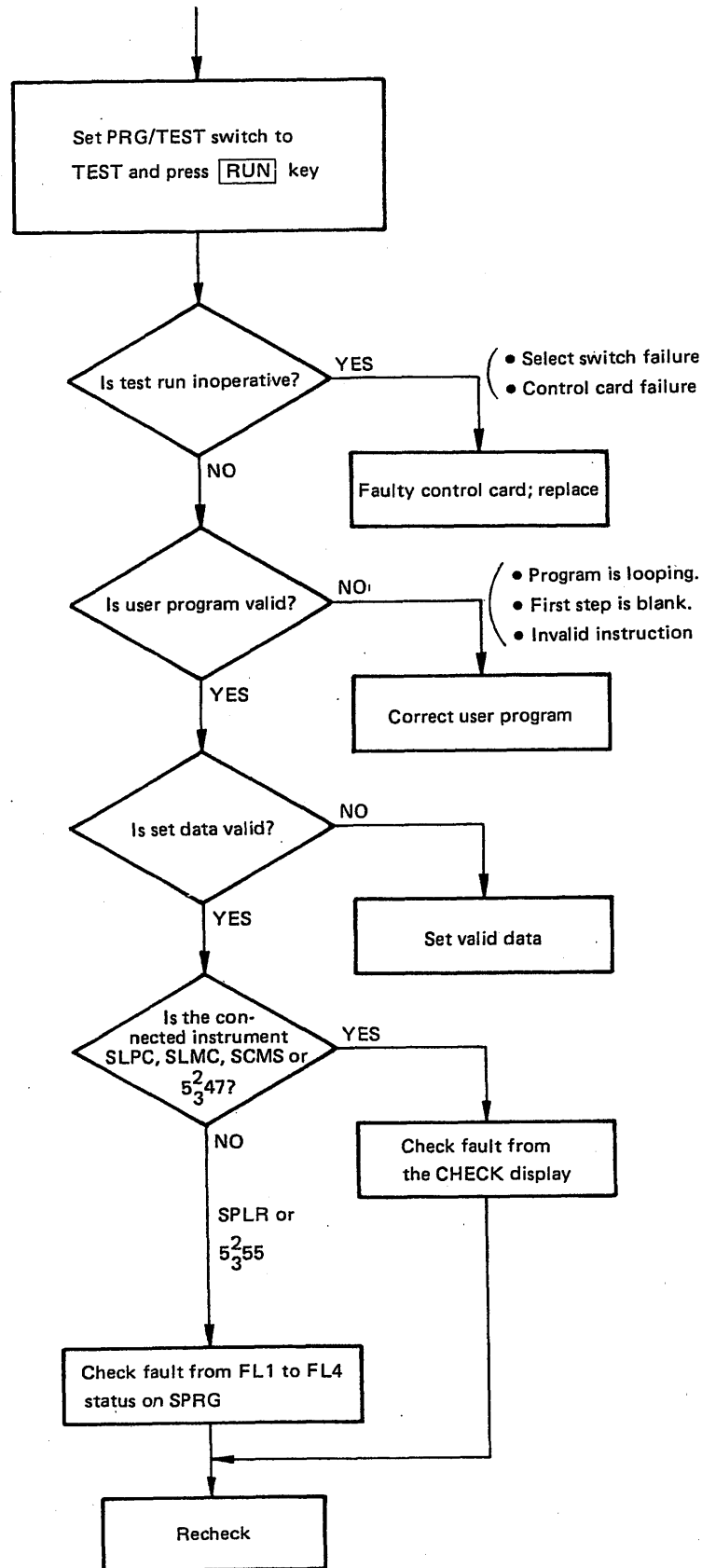

[5] ROM read abnormal
 [6] ROM write abnormal

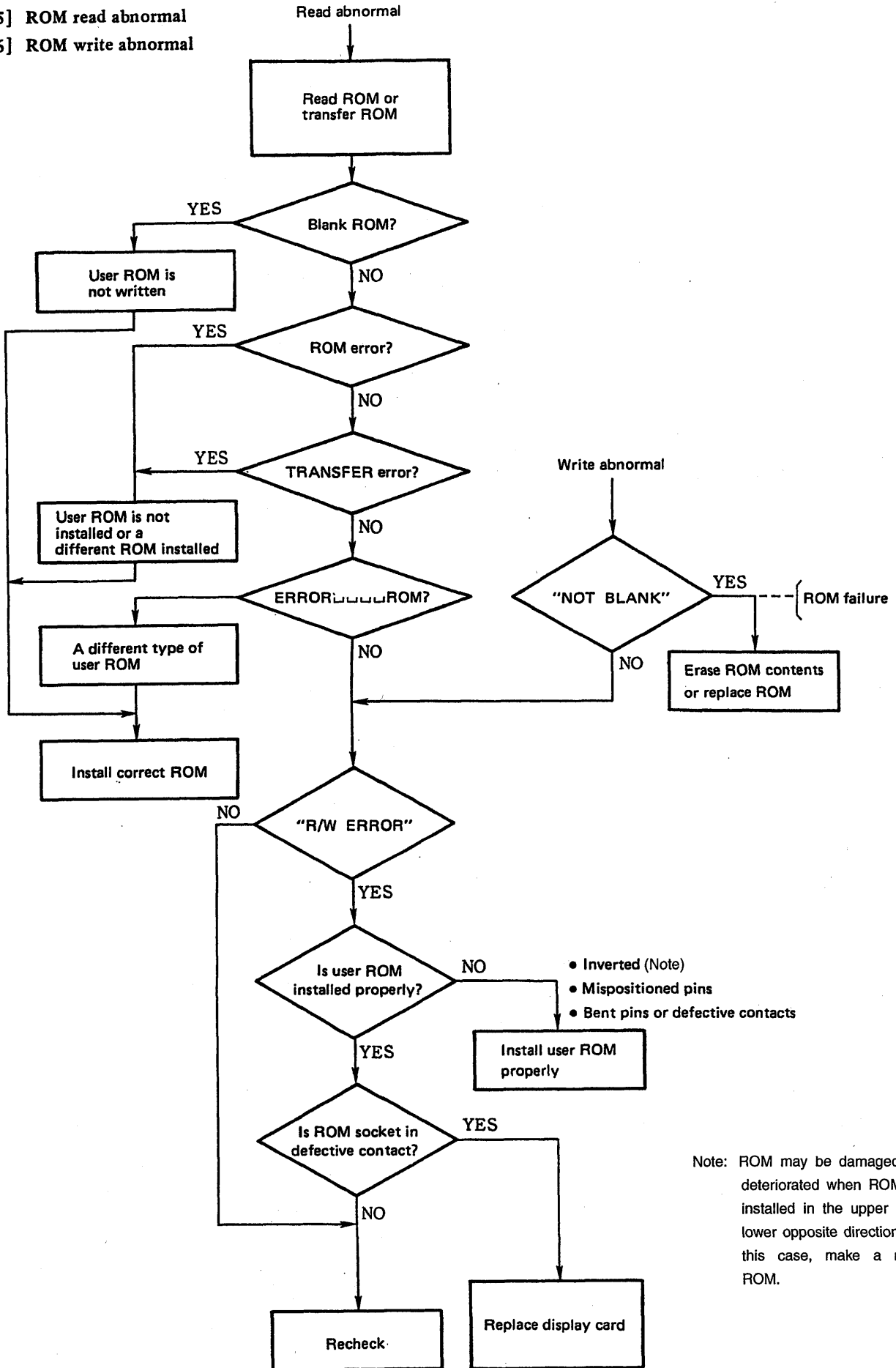

[7] Print abnormal

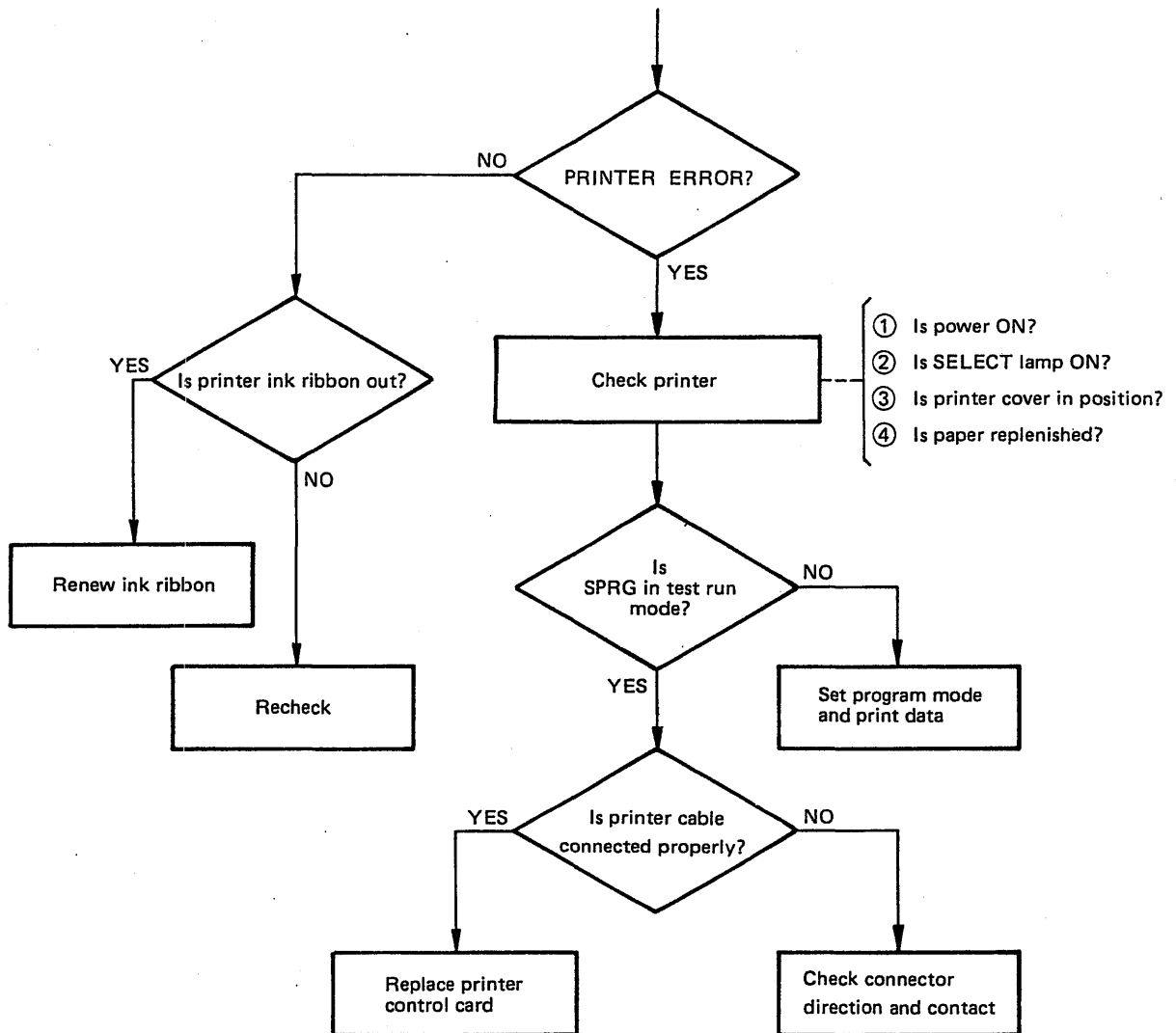

7-2. Component Replacement.

Follow Sections 7-2-1 and 7-2-2 for removal and replacement of a faulty unit.

7-2-1. Disassembly.

Figure 7-2-1 and 7-2-2 illustrate the procedures for disassembling the Programmer.

- (1) Remove the two screws ① and associated two washers on the bottom of the housing. Remove the two screws ② and associated two washers for the power supply cable connection. Remove the programmer internal assembly from the housing.
- (2) Remove the two screws ③ on each side of the front panel, and the two screws ④ fastening the connector cable guide.
- (3) Lift the keyboard to disconnect two connectors for the control card and power supply card. Thus the keyboard and power supply card are separated.
- (4) Remove the two screws ⑤ that fasten the power supply card to the bracket. The power supply card is now free.
- (5) To separate the control card from the display card, proceed as follows:
Remove the four screws ⑥ that connect the control card to the display card with the four studs ⑦.
Disconnect connector CN1 from the display card.

- (6) To remove the cover from the display card, remove the four studs ⑦. Do not perform any further disassembly.

7-2-2. Reassembly.

Reassemble in the reverse order to the above disassembly procedures. Check that the connectors are connected correctly.

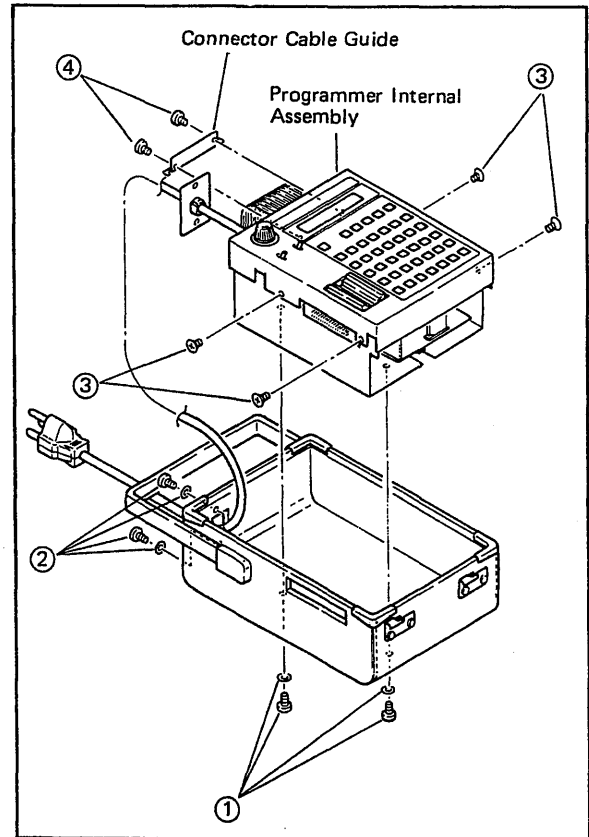

Figure 7-2-1. Model SPRG Programmer Disassembly Drawing - 1.

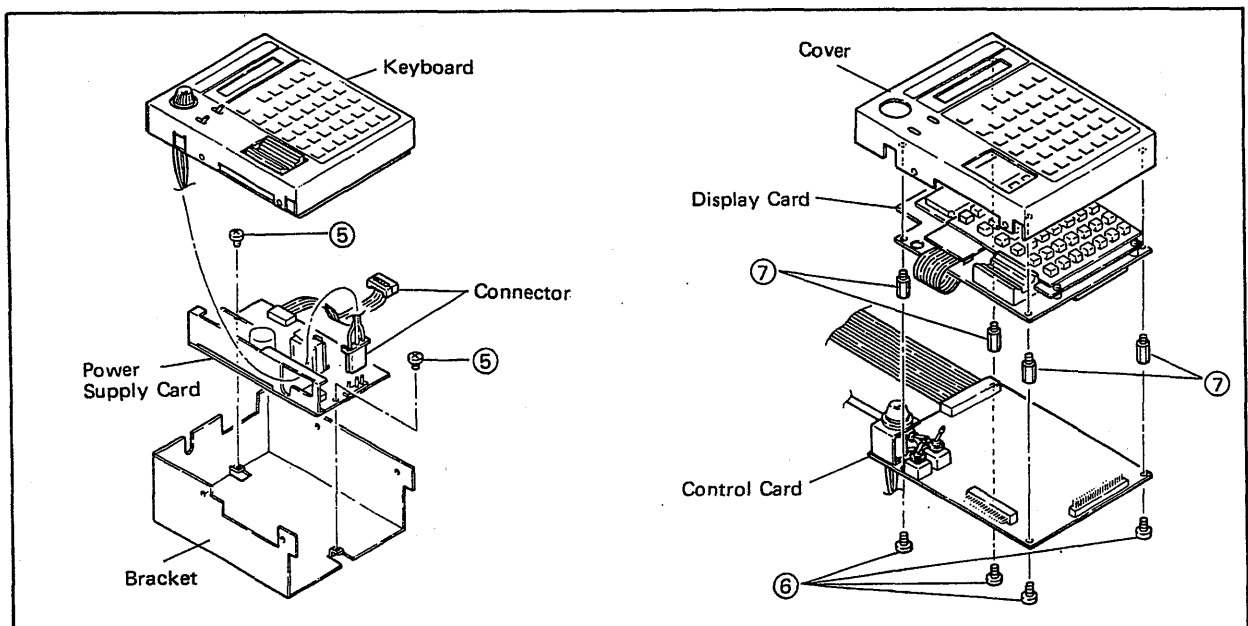
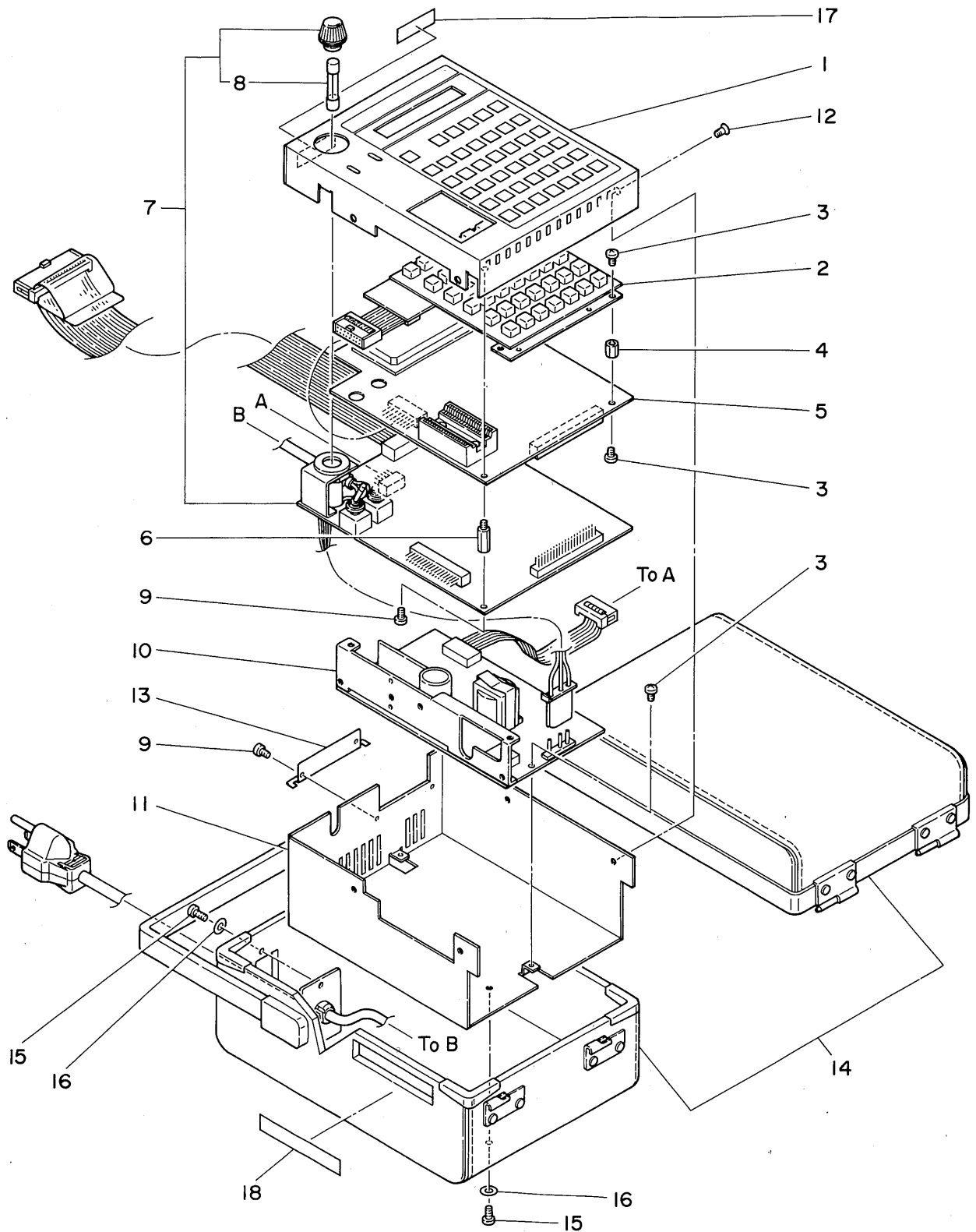

Figure 7-2-2. Model SPRG Programmer Disassembly Drawing - 2.

Customer Maintenance Parts List

Model SPRG (Style E)
Programmer

YEW SERIES 80



Item	Part No.	Qty	Description
1	—	1	Cover Assembly
2	E9714JT	1	Rubber Switch
3	Y9304JB	8	Pan H. Screw, M3 x 4
4	—	4	Stud
5	E9714NA	1	Display Board Assembly
6	—	4	Stud
7	E9714JQ	1	Control Board Assembly
8	S9510VK	1	Fuse (1 A)
9	—	8	Pan H. Screw, M3 x 6
10	E9716YD	1	Power Unit Assembly
11	—	1	Bracket
12	Y9304EB	4	F.H. Screw, M3 x 4
13	E9712AC	1	Bracket
14	E9714JJ	1	Case
15	Y9308LE	4	B.H. Screw, M3 x 8
16	Y9301WE	4	Washer
17	Y9023NP	1	Tag No. Label
18	E9712AZ	1	Label