

UM10856

User manual for dI2C demo board

Rev. 1 — 13 July 2015

User manual

Document information

Info	Content
Keywords	dI2C-bus, differential I ² C-bus buffer, PCA9614, PCA9615, PCA9616
Abstract	User manual for the dI2C demo board OM15323. This demo board will make it easy to test and design with PCA9614, PCA9615 and PCA9616, a differential I ² C-bus buffer.



Revision history

Rev	Date	Description
1	20150713	Initial version.

Contact information

For more information, please visit: <http://www.nxp.com>

For sales office addresses, please send an email to: salesaddresses@nxp.com

1. Introduction

The dI2C demo board OM13523 is for demonstration of the differential I2C-bus working better in noise and ground offset environment than standard I2C-bus. The two dI2C demo boards can be used to see the improvement of signal integrity in a noisy environment or a system that has many different power sources creating different ground offset.

In the system block diagram (Figure 1), the I2C-bus between the Boot Bus Controller and the CPU/Memory board has a lot of high speed data transmission; therefore the I2C-bus may pick up some noise. The fan and power supply modules may have different power sources; they may have a different ground offset level. To make a better I2C-bus system, install dI2C devices to isolate noise and ground offset in a system.

This user manual shows how to use a dI2C demo board on an existing system.

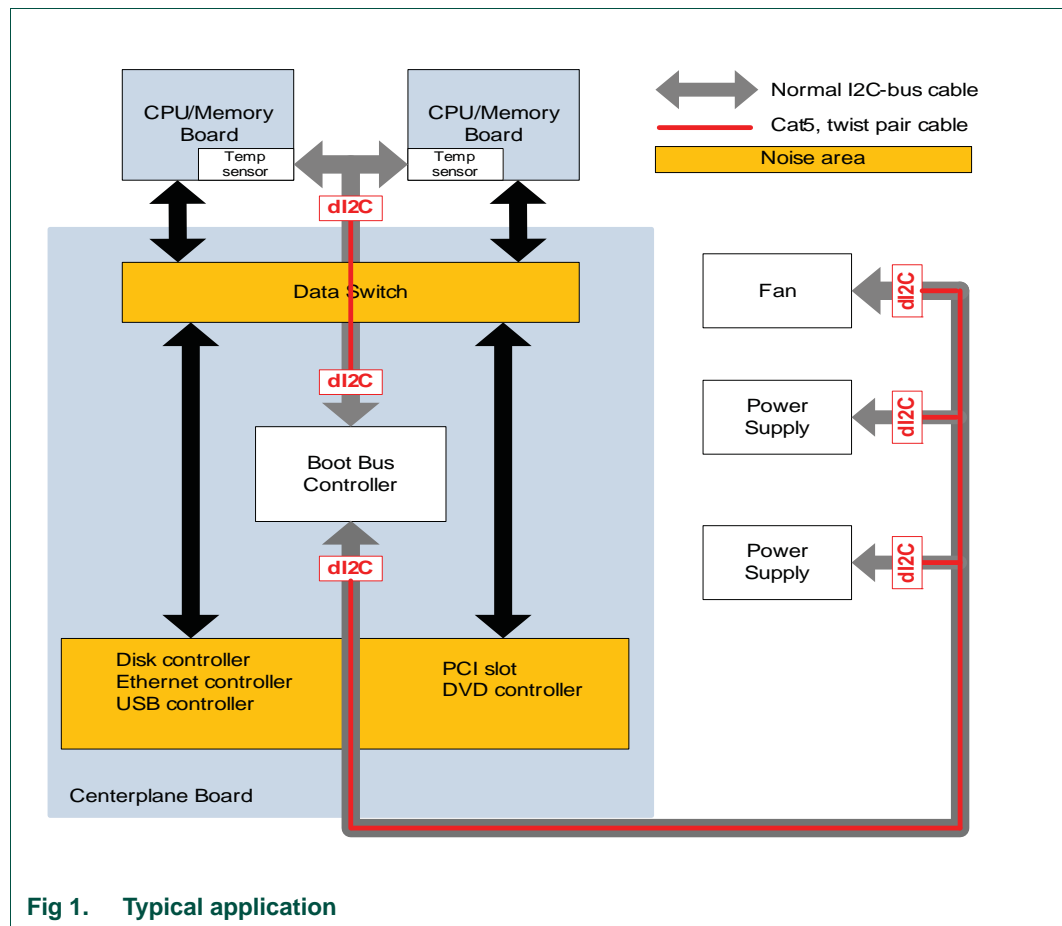

2. Key features

- A complete evaluation platform for PCA9616, (or PCA9614 and PCA9615)
- Easy to connect to an existing system
- Convenient test point for easy scope measurement and signal access

3. Getting started

3.1 Assumptions

Familiarity with the I²C-bus is recommended.

3.1.1 Static handling requirements

This device is sensitive to ElectroStatic Discharge (ESD). Therefore care should be taken during transport and handling. You must use a ground strap or touch the PC case or other grounded source before unpacking or handling the hardware.

3.1.2 System requirement

The OM13523 demo card can be used with Fm+ Development Board (OM13260), or customer's application system.

3.1.3 Schematic of dI2C demo board

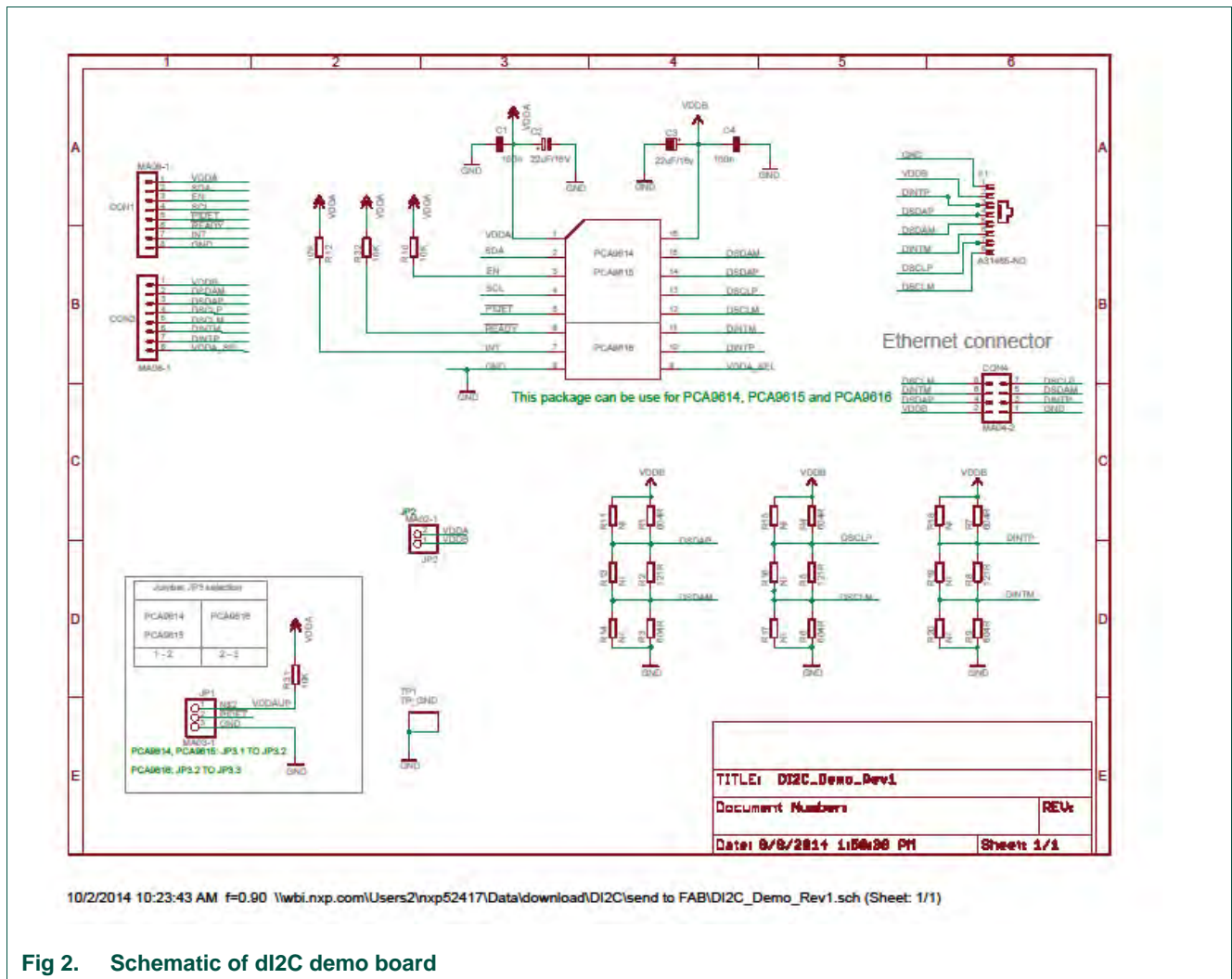

Fig 2. Schematic of dI2C demo board

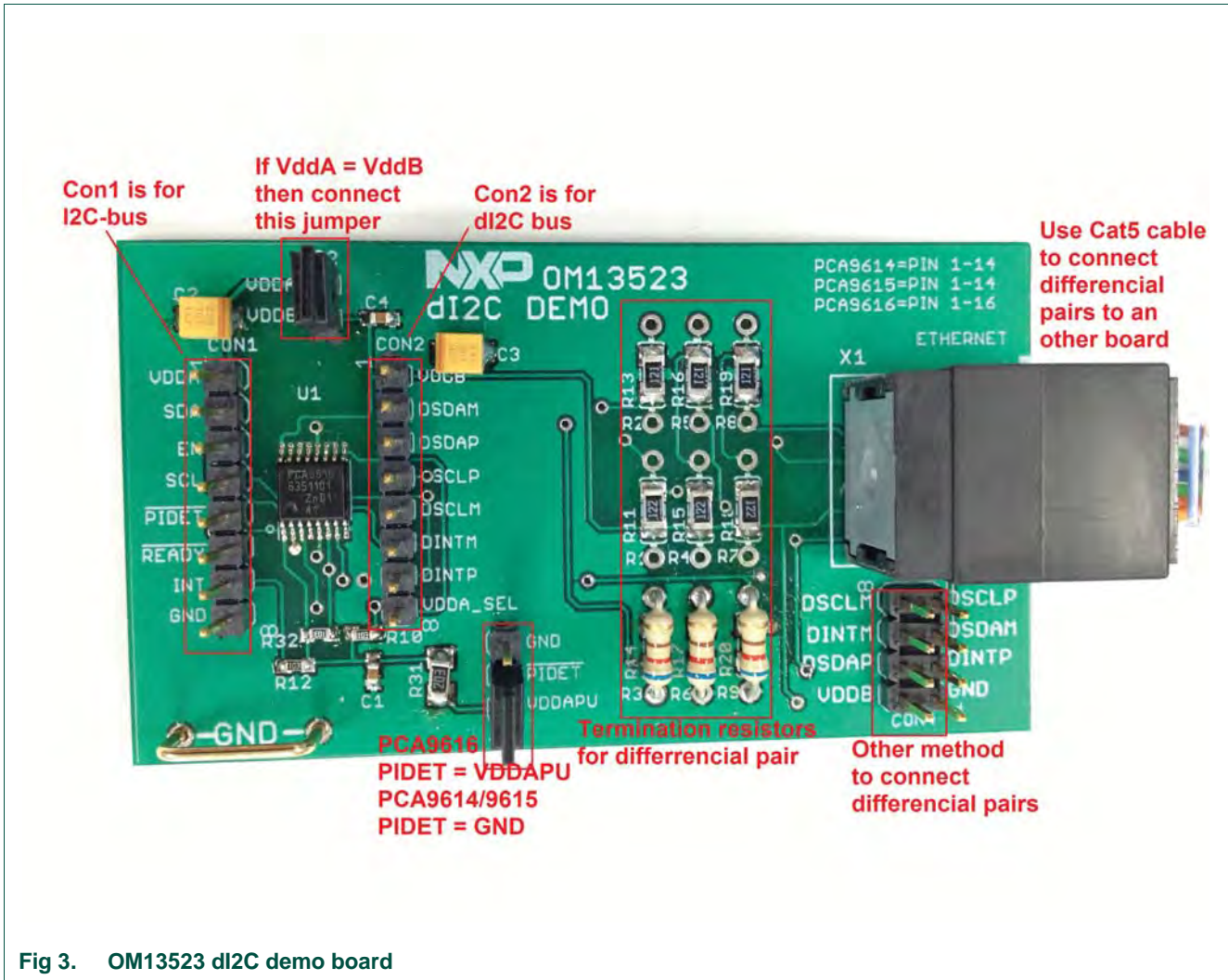

Fig 3. OM13523 dI2C demo board

3.1.4 Bill of materials

Table 1. Bill of materials

Part	Value	Package	Part #	Description
C1	100n	C0603	399-1095-1-ND	SMD capacitor
C2	22uF/16V	A/3216-18R	1276-2728-1-ND	SMD capacitor
C3	22uF/16v	A/3216-18R	1276-2728-1-ND	SMD capacitor
C4	100n	C0603	399-1095-1-ND	SMD capacitor
CON1	MA08-1	MA08-1	609-3235-ND	dI2C part connector 1
CON2	MA08-1	MA08-1	609-3235-ND	dI2C part connector 2
CON4	MA04-2	MA04-2	609-3203-ND	Cable connector
JP1	MA03-1	1X03	WM8073-ND	Part selector header
JP2	MA02-1	1X02	WM8072-ND	VDDB power selector header
R1	604R	M1206	541-604FCT-ND	Terminator resistor
R10	10K	R0603	1276-5930-2-ND	EN, pull-up resistor

Table 1. Bill of materials ...continued

Part	Value	Package	Part #	Description
R11	NI	0204/7	NONE	Terminator resistor op
R12	10K	R0603	1276-5930-2-ND	INT, pull-up resistor
R13	NI	0204/7	NONE	Terminator resistor op
R14	NI	0204/7	NONE	Terminator resistor op
R15	NI	0204/7	NONE	Terminator resistor op
R16	NI	0204/7	NONE	Terminator resistor op
R17	NI	0204/7	NONE	Terminator resistor op
R18	NI	0204/7	NONE	Terminator resistor op
R19	NI	0204/7	NONE	Terminator resistor op
R2	121R	M1206	541-131FCT-ND	Terminator resistor
R20	NI	0204/7	NONE	Terminator resistor op
R3	604R	M1206	541-604FCT-ND	Terminator resistor
R31	10K	M1206	1276-5930-2-ND	Pull-up resistor
R32	10K	R0603	1276-5930-2-ND	!Ready, pull-up resistor
R4	604R	M1206	541-604FCT-ND	Terminator resistor
R5	121R	M1206	541-131FCT-ND	Terminator resistor
R6	604R	M1206	541-604FCT-ND	Terminator resistor
R7	604R	M1206	541-604FCT-ND	Terminator resistor
R8	121R	M1206	541-131FCT-ND	Terminator resistor
R9	604R	M1206	541-604FCT-ND	Terminator resistor
TP1	TP_GND	TP_GND	952-1873	GND
U1	PCA9410	TSSOP16_4X4MM	PCA9616	dl2C part
X1	A31465-ND	RJ45-NO-SHIELD	A31465-ND	Internet connector

3.1.5 Power supply

The dl2C demo board needs two power supplies for I2C-bus (VDDA) and dl2C-bus (VDDB).

- Using Fm+ Development Board (Fm+ DB): There is no direct connector to the Fm+ DB. The dl2C demo board can draw the power from an Fm+ DB using either 3.3 V headers (CN21) or 5 V headers (CN22) to the VDDA of CON1 on the dl2C demo board. VDDB can use the same power as VDDA by connecting JP2, or using jumper wire from CN21 or CN22 of Fm+ DB (see [Figure 4](#)).

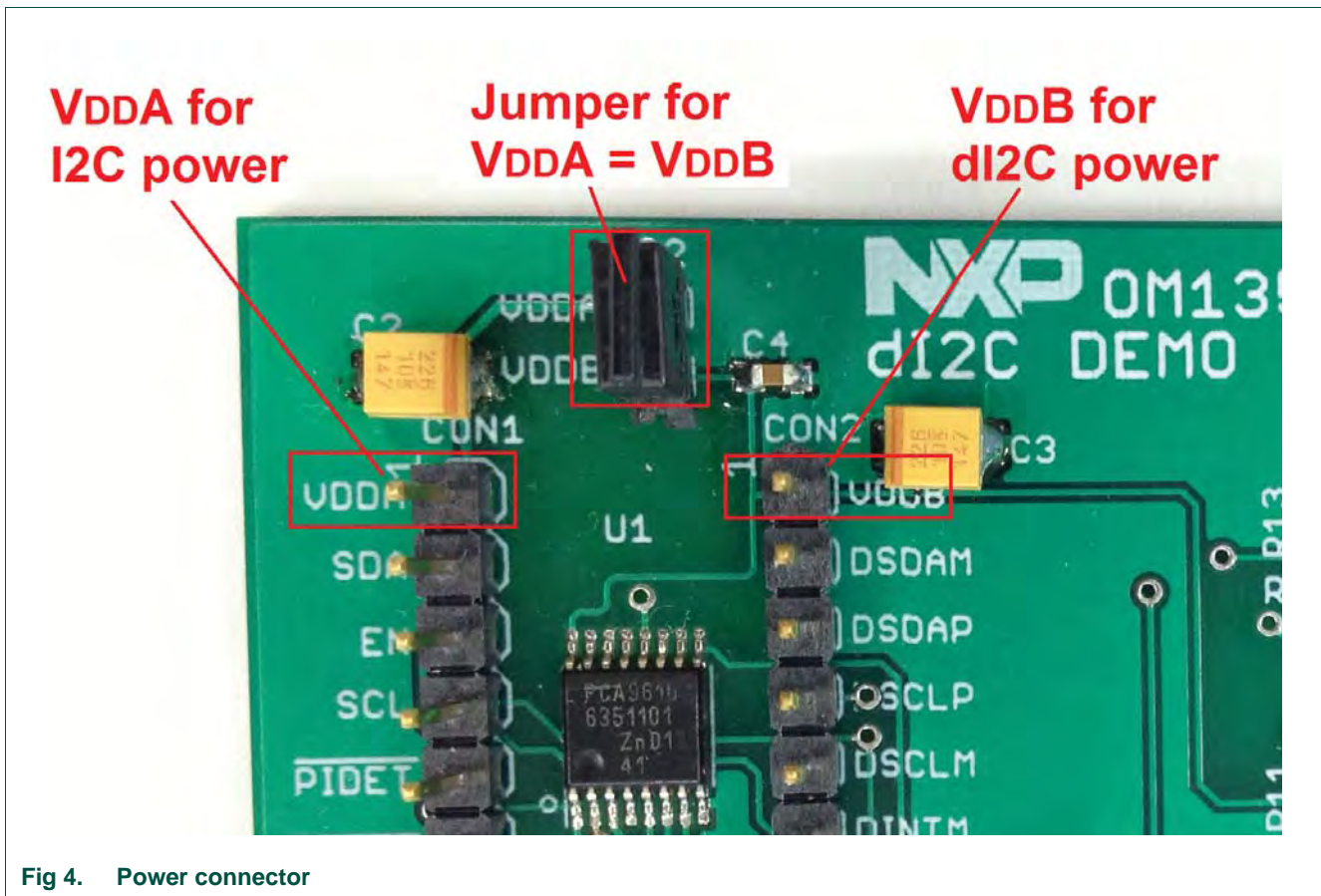

Fig 4. Power connector

- User application board: CON1 pin VDDA is for the I2C-bus power and CON2 pin VDDB is for dI2C-bus power. On an application board, the I2C-bus pull-up power should connect to the VDDA power. VDDB is the power for PCA9616 and differential bus signals. VDDB can be set the same as VDDA by adding a jumper header on JP2, if VDDA is between 3.0 V and 5.0 V.

3.1.6 I2C-bus side

The I2C-bus on the dI2C demo board does not have the pull up resistors on SLC and SDA signals. The pull-up resistors should be taken care of by the I2C master board (Fm+ DB or application board).

INT signal can be used as an interrupt signal to the microcontroller or a reset signal to the slave devices. The INT signal has a 10K pull-up to VDDB on the dI2C demo board.

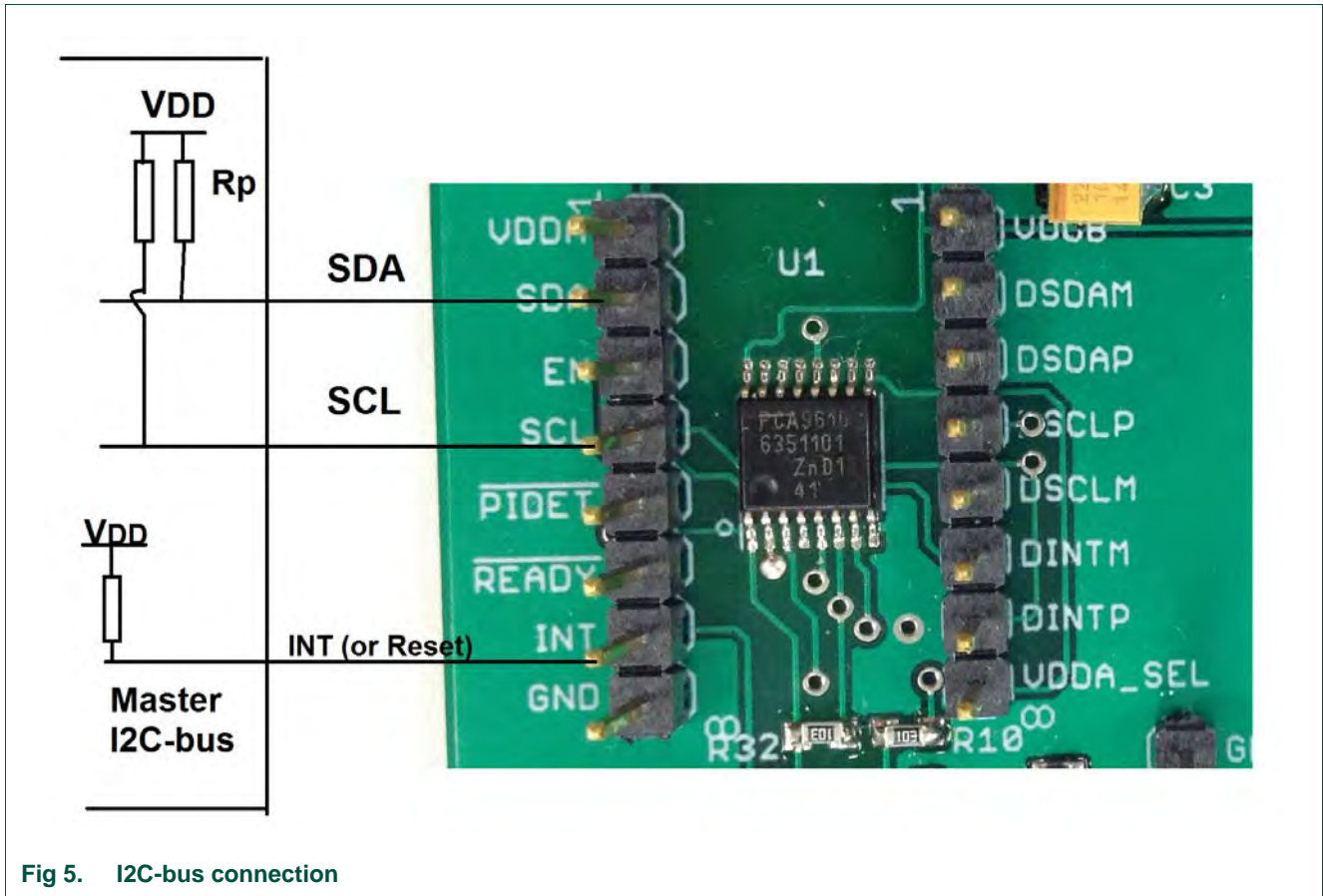

Fig 5. I2C-bus connection

3.1.7 dI2C-bus side

dI2C-bus has three pairs of differential signals on the dI2C demo board. All of the pairs are connected to RJ45 through the termination resistors. Please see schematic (Figure 6) for more detail. RJ45 is internet connector; it can use cat5/6 cable to connect to the other dI2C board. A user can have his or her own cable and it can be connected to CON4.

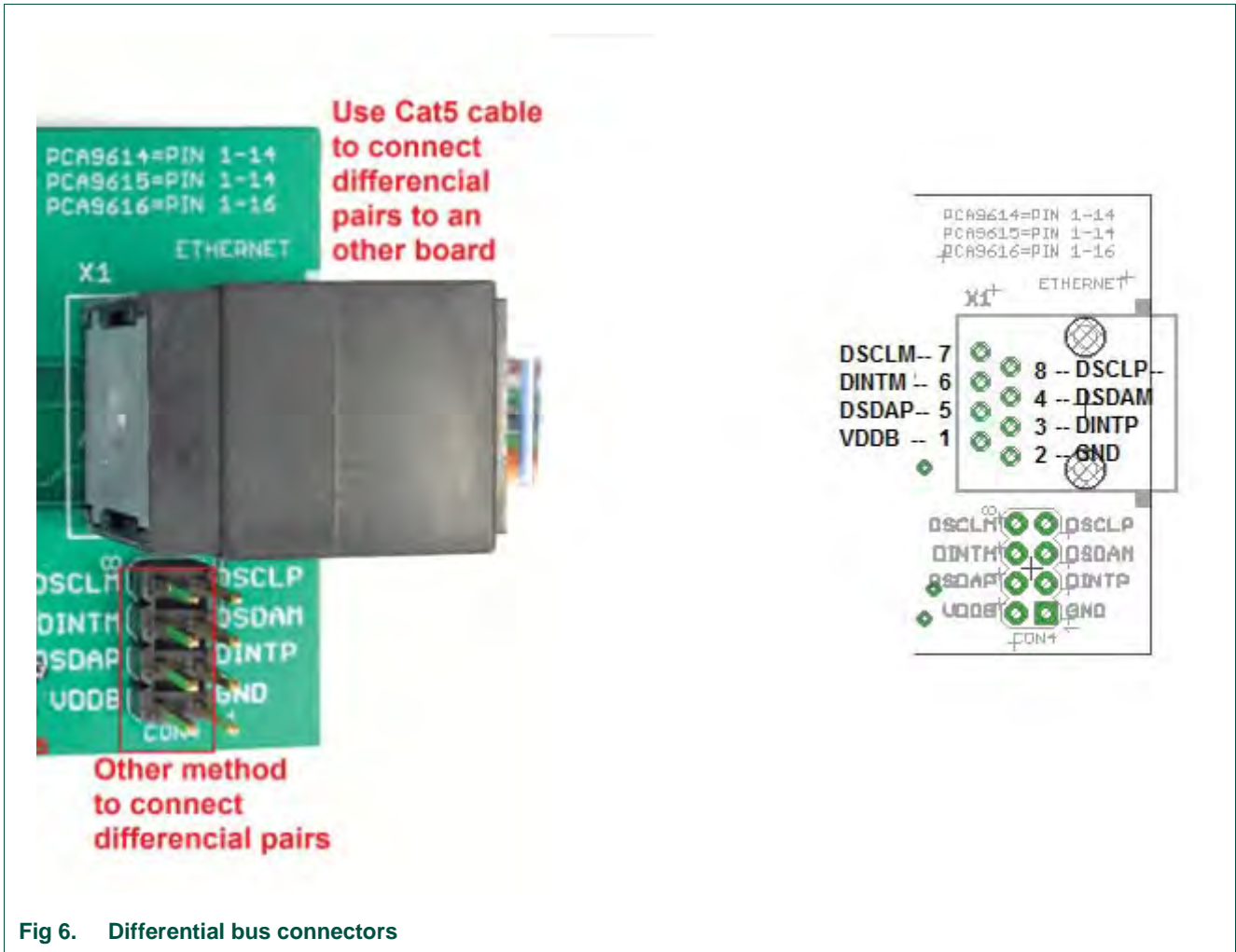

Fig 6. Differential bus connectors

3.1.8 Other signals

The dl2C demo board is designed ready to use; therefore, all other signals have been set to running mode. Please see the schematic in [Figure 2](#) for more detail.

4. How to run a demo on Fm+ board with dl2C demo board

4.1 How to connect dl2C to Fm+ DM

1. dl2C demo board #1: connect SCL, SDA, VDDA and GND to SCL1, SDA1, 3.3V and GND of Fm+ DM #1 respectively.
2. dl2C demo board #2: connect SCL, SDA, VDDA and GND to SCL2, SDA2, 3.3V and GND of Fm+ DM #2 respectively.
3. Use a CAT6 cable to connect the two dl2C DMs together
4. Install jumpers on both dl2C demo boards JP2 and JP1 (PIDET - VDDAPU)
5. Connect GPIO target board: the first GPIO target board connects to CN10 of Fm+ board #1 and the second one connects to CN20 of Fm+ board #2

4.2 Fm+ DM source code for expert mode

```
Expert Mode Data File
//Hardware setup: Two Fm+ boards OM13260, two dI2C demo boards OM13523, CAT6 cable,
    and two GPIO Target boards OM13303
//Fm+ DB#1, install jumper on JP10 = GND; no jumper on CN12; connect OM13303 board to
    CN10 on Fm+ DM#1
//Fm+ DB#2, install jumper on JP20 = GND; no jumper on CN12; connect OM13303 board to
    CN20 on Fm+ DM#2
//dI2C DB OM13523, JP2 =1&2; JP1=1&2
44,Write,Yes,200,FE,Comments: Please open this file in text editor for boards setup
44,Write,Yes,200,FE,Comments: Write to PCA9672 addr 0x44 on bus #1; set bit0=0
44,Write,Yes,200,FD,Comments: Write to PCA9672 addr 0x44 on bus #1; set bit1=0
44,Write,Yes,200,FB,Comments: Write to PCA9672 addr 0x44 on bus #1; set bit2=0
44,Write,Yes,200,F7,Comments: Write to PCA9672 addr 0x44 on bus #1; set bit3=0
44,Write,Yes,200,EF,Comments: Write to PCA9672 addr 0x44 on bus #1; set bit4=0
44,Write,Yes,200,DF,Comments: Write to PCA9672 addr 0x44 on bus #1; set bit5=0
44,Write,Yes,200,BF,Comments: Write to PCA9672 addr 0x44 on bus #1; set bit6=0
44,Write,Yes,200,7F,Comments: Write to PCA9672 addr 0x44 on bus #1; set bit7=0

//The data below are sent from bus1 through dI2C buffer to bus2 to drive PCA9672
46,Write,Yes,200,7F,Comments: Write to PCA9672 addr 0x46 on bus #2; set bit7=0
46,Write,Yes,200,BF,Comments: Write to PCA9672 addr 0x46 on bus #2; set bit6=0
46,Write,Yes,200,DF,Comments: Write to PCA9672 addr 0x46 on bus #2; set bit5=0
46,Write,Yes,200,EF,Comments: Write to PCA9672 addr 0x46 on bus #2; set bit4=0
46,Write,Yes,200,F7,Comments: Write to PCA9672 addr 0x46 on bus #2; set bit3=0
46,Write,Yes,200,FB,Comments: Write to PCA9672 addr 0x46 on bus #2; set bit2=0
46,Write,Yes,200,FD,Comments: Write to PCA9672 addr 0x46 on bus #2; set bit1=0
46,Write,Yes,200,FE,Comments: Write to PCA9672 addr 0x46 on bus #2; set bit0=0

Sequence:01,02,03,04,05,06,07,08,09,10,11,12,13,14,15,16,17

//;results: LED GPIO target board on JP10 runs from LED7 to LED0, other LED board runs
    form LED0 to LED7
```

4.3 Open source code in expert mode

Copy the source code in [Section 4.2](#) above in a text file and save it with "name.txt", then open name.txt in expert mode of NXP's Fm+ board GUI software by selecting Device and Expert Mode.

4.4 Board connectivity

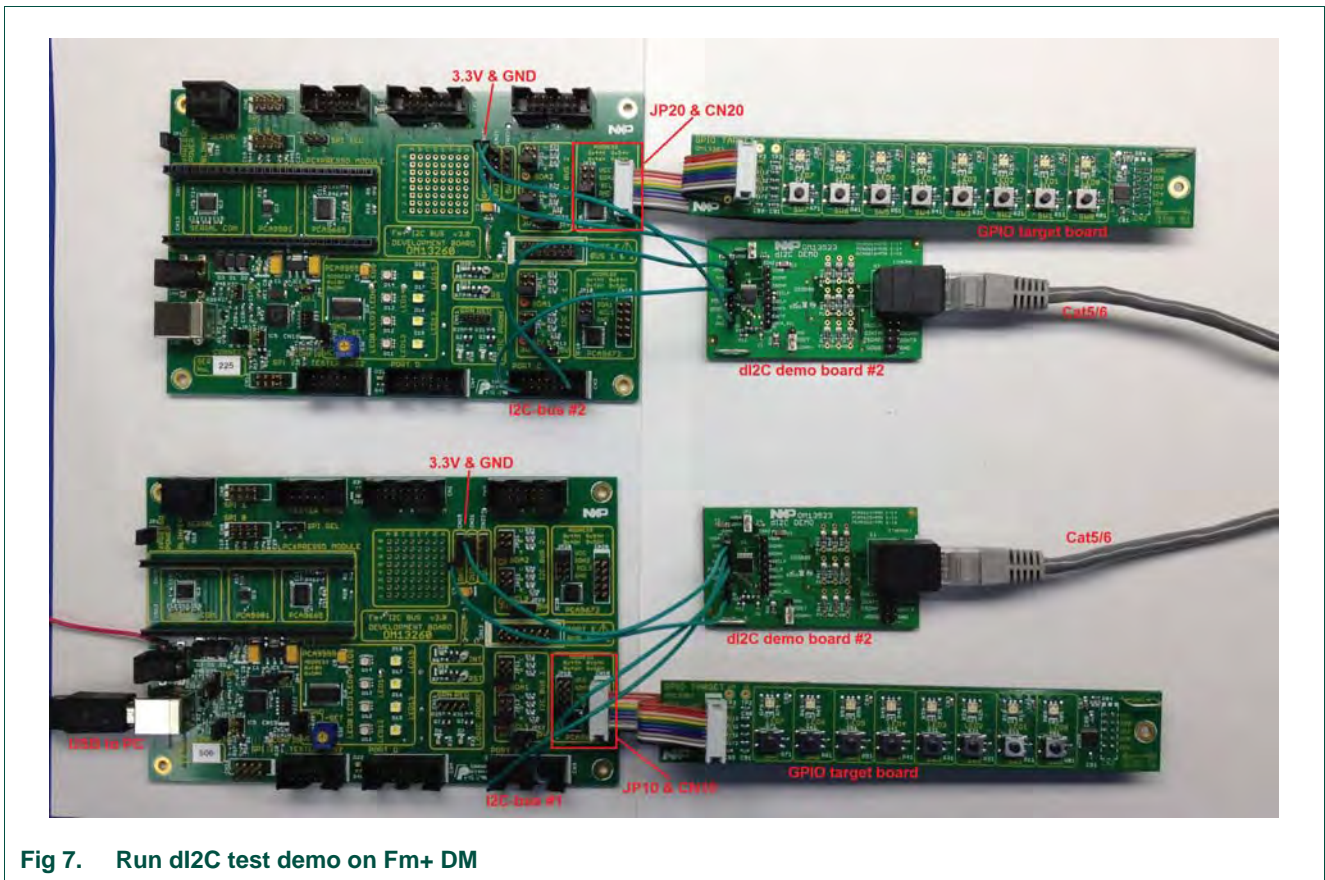

Fig 7. Run dI2C test demo on Fm+ DM

4.5 How it works

Fm+ DM #1 has an I2C master and it sends commands on bus #1 to control two GPIO target boards on both Fm+ DMs. When the LEDs on GPIO target board #2 is toggling, that means the data has been transferred from Fm+ DM #1 to Fm+ DM #2 through dI2C demo boards.

5. Legal information

5.1 Definitions

Draft — The document is a draft version only. The content is still under internal review and subject to formal approval, which may result in modifications or additions. NXP Semiconductors does not give any representations or warranties as to the accuracy or completeness of information included herein and shall have no liability for the consequences of use of such information.

5.2 Disclaimers

Limited warranty and liability — Information in this document is believed to be accurate and reliable. However, NXP Semiconductors does not give any representations or warranties, expressed or implied, as to the accuracy or completeness of such information and shall have no liability for the consequences of use of such information. NXP Semiconductors takes no responsibility for the content in this document if provided by an information source outside of NXP Semiconductors.

In no event shall NXP Semiconductors be liable for any indirect, incidental, punitive, special or consequential damages (including - without limitation - lost profits, lost savings, business interruption, costs related to the removal or replacement of any products or rework charges) whether or not such damages are based on tort (including negligence), warranty, breach of contract or any other legal theory.

Notwithstanding any damages that customer might incur for any reason whatsoever, NXP Semiconductors' aggregate and cumulative liability towards customer for the products described herein shall be limited in accordance with the *Terms and conditions of commercial sale* of NXP Semiconductors.

Right to make changes — NXP Semiconductors reserves the right to make changes to information published in this document, including without limitation specifications and product descriptions, at any time and without notice. This document supersedes and replaces all information supplied prior to the publication hereof.

Suitability for use — NXP Semiconductors products are not designed, authorized or warranted to be suitable for use in life support, life-critical or safety-critical systems or equipment, nor in applications where failure or malfunction of an NXP Semiconductors product can reasonably be expected to result in personal injury, death or severe property or environmental damage. NXP Semiconductors and its suppliers accept no liability for inclusion and/or use of NXP Semiconductors products in such equipment or applications and therefore such inclusion and/or use is at the customer's own risk.

Applications — Applications that are described herein for any of these products are for illustrative purposes only. NXP Semiconductors makes no representation or warranty that such applications will be suitable for the specified use without further testing or modification.

Customers are responsible for the design and operation of their applications and products using NXP Semiconductors products, and NXP Semiconductors accepts no liability for any assistance with applications or customer product

design. It is customer's sole responsibility to determine whether the NXP Semiconductors product is suitable and fit for the customer's applications and products planned, as well as for the planned application and use of customer's third party customer(s). Customers should provide appropriate design and operating safeguards to minimize the risks associated with their applications and products.

NXP Semiconductors does not accept any liability related to any default, damage, costs or problem which is based on any weakness or default in the customer's applications or products, or the application or use by customer's third party customer(s). Customer is responsible for doing all necessary testing for the customer's applications and products using NXP Semiconductors products in order to avoid a default of the applications and the products or of the application or use by customer's third party customer(s). NXP does not accept any liability in this respect.

Export control — This document as well as the item(s) described herein may be subject to export control regulations. Export might require a prior authorization from competent authorities.

Evaluation products — This product is provided on an "as is" and "with all faults" basis for evaluation purposes only. NXP Semiconductors, its affiliates and their suppliers expressly disclaim all warranties, whether express, implied or statutory, including but not limited to the implied warranties of non-infringement, merchantability and fitness for a particular purpose. The entire risk as to the quality, or arising out of the use or performance, of this product remains with customer.

In no event shall NXP Semiconductors, its affiliates or their suppliers be liable to customer for any special, indirect, consequential, punitive or incidental damages (including without limitation damages for loss of business, business interruption, loss of use, loss of data or information, and the like) arising out of the use of or inability to use the product, whether or not based on tort (including negligence), strict liability, breach of contract, breach of warranty or any other theory, even if advised of the possibility of such damages.

Notwithstanding any damages that customer might incur for any reason whatsoever (including without limitation, all damages referenced above and all direct or general damages), the entire liability of NXP Semiconductors, its affiliates and their suppliers and customer's exclusive remedy for all of the foregoing shall be limited to actual damages incurred by customer based on reasonable reliance up to the greater of the amount actually paid by customer for the product or five dollars (US\$5.00). The foregoing limitations, exclusions and disclaimers shall apply to the maximum extent permitted by applicable law, even if any remedy fails of its essential purpose.

Translations — A non-English (translated) version of a document is for reference only. The English version shall prevail in case of any discrepancy between the translated and English versions.

5.3 Trademarks

Notice: All referenced brands, product names, service names and trademarks are the property of their respective owners.

6. Contents

1	Introduction	3
2	Key features	3
3	Getting started	4
3.1	Assumptions	4
3.1.1	Static handling requirements	4
3.1.2	System requirement	4
3.1.3	Schematic of dl2C demo board	4
3.1.4	Bill of materials	5
3.1.5	Power supply	6
3.1.6	I2C-bus side	7
3.1.7	dl2C-bus side	8
3.1.8	Other signals	9
4	How to run a demo on Fm+ board with dl2C demo board	9
4.1	How to connect dl2C to Fm+ DM	9
4.2	How to connect dl2C to Fm+ DM	10
4.3	Use source code in expert mode of NXP Fm+ board GUI	10
4.4	Board connectivity	11
4.5	How it works	11
5	Legal information	12
5.1	Definitions	12
5.2	Disclaimers	12
5.3	Trademarks	12
6	Contents	13

Please be aware that important notices concerning this document and the product(s) described herein, have been included in section 'Legal information'.

© NXP Semiconductors N.V. 2015.

All rights reserved.

For more information, please visit: <http://www.nxp.com>

For sales office addresses, please send an email to: salesaddresses@nxp.com

Date of release: 13 July 2015

Document identifier: UM10856