

PCM4806X

IDEA Drive

Hardware Manual



Haydon
Motion Solutions



www.haydonkerk.com

All Rights Reserved

9-2011

Table of Contents

Revision History	3
Introduction	4
Specifications	5
Drawing	6
Connections	7
Basic Wiring	7
Digital I/O Pin Descriptions	8
Digital I/O Wiring	9
Digital Output Wiring Examples	10

Revision History

Date	Description
July 2011	Initial version
September 2011	Updated part number to PCM4806X

Introduction

This manual is intended to provide basic hardware specifications for the Haydon Kerk PCM4806X IDEA drive. For detailed information on use and programming of the drive, please refer to the IDEA Drive User's Manual, available at idea-drive.com.

Specifications

Attribute	Value
Drive Input Voltage Range	12-48Vdc
Maximum Drive Current (per phase)	0.6Arms (Plus optional 30% boost during ramping)
Step Modes	Full, Half, ¼, 1/8, 1/16, 1/32, 1/64
Communications	USB (Mini B connector)
Digital I/O Voltage Range	5-24Vdc
Digital Inputs	4
Digital Sinking Outputs	4
Digital Output Maximum Sinking Current	200mA (each)
Digital Input Maximum Current	4mA (each)
Maximum Temperature	70°C (Measured at heat sink)
Program Storage Size-Type	85 Kbytes-Flash
Maximum Number of Stored Programs	85, Referenced by 10 character program names
Position counter range	64bit
Type of Ramping	Trapezoidal
Interrupt sources	4 inputs (rising, falling or both edges), internal position counter (when reaching a programmed position).

Drawing

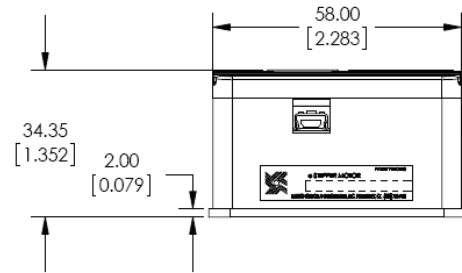
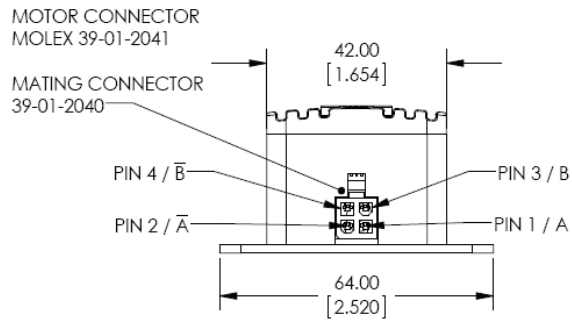
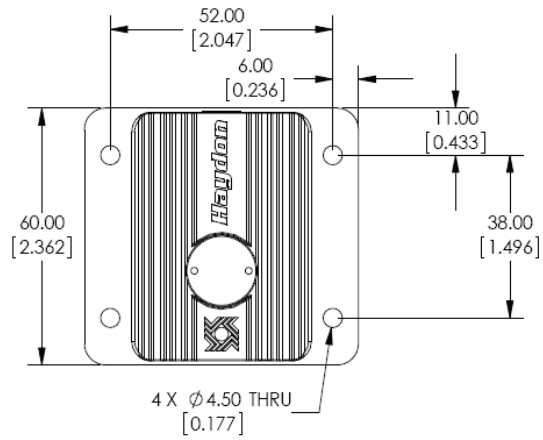

Connections

Basic Wiring: To connect power to the drive and control it with the IDEA Drive

User Interface you will need the following:

- A power supply, 12-48VDC.
- A PC
- Power cable (available from Haydon Kerk p/n 56-1348)
- USB to Mini B USB cable (available from Haydon Kerk p/n 56-1346)
- 10 wire I/O cable (available from Haydon Kerk p/n 56-1352). Note: this cable is only required if the actuator is being communicated to from an external switch, etc. or the actuator is being programmed to send a signal to an outside device such as a light. (or LED)
- Haydon motor terminated with Molex connector 39-01-2040.

The following is the proper wiring diagram for the IDEA drive, power supply and PC. The I/O cable is omitted.

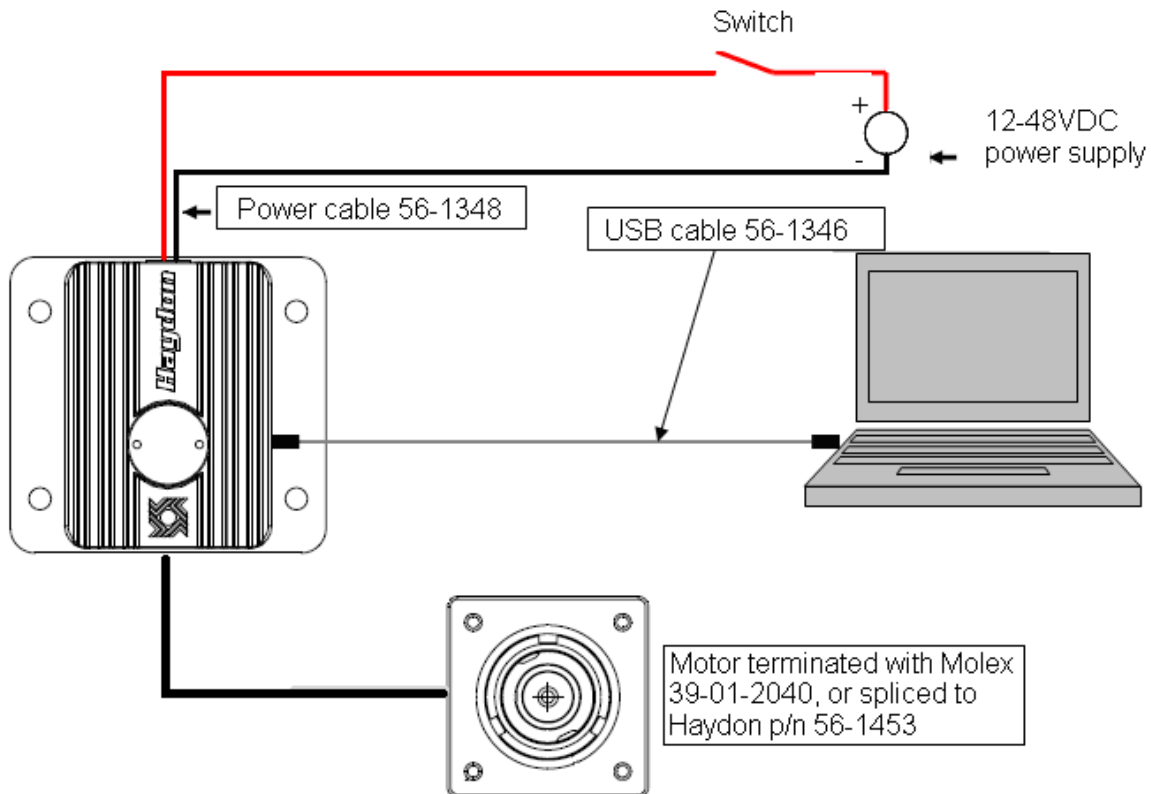

After wiring as shown, turn on power supply and close the switch.

Digital I/O Pin Descriptions

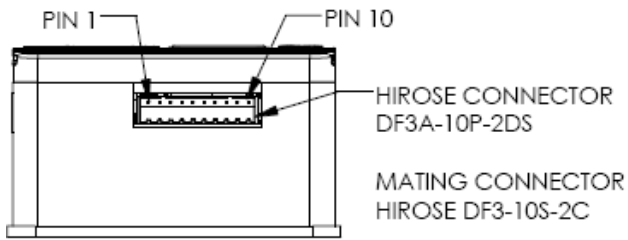

PIN POSITION	DESCRIPTION	NOTES
PIN 1	GROUND I/O SUPPLY	5 TO 24 VDC
PIN 2	+ I/O SUPPLY	5 TO 24 VDC
PIN 3	INPUT 1	
PIN 4	INPUT 2	
PIN 5	INPUT 3	
PIN 6	INPUT 4	
PIN 7	OUTPUT 1	
PIN 8	OUTPUT 2	
PIN 9	OUTPUT 3	
PIN 10	OUTPUT 4	

Open Collector Output Pin Description

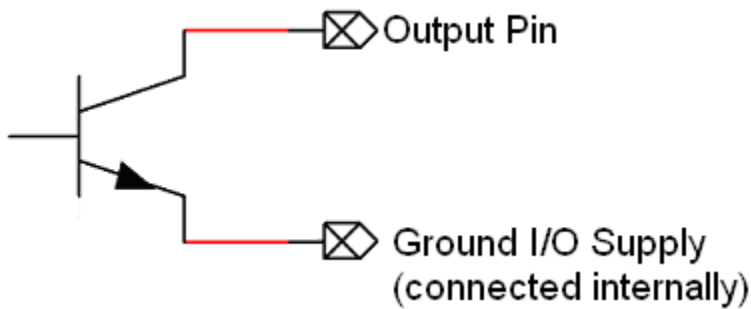

Input Pin Description

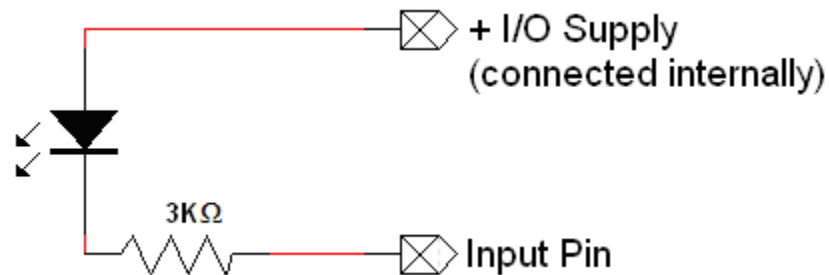

Digital I/O Wiring

The IDEA drive has four optically isolated inputs and four optically isolated open-collector outputs. The voltage range for these is 5-24VDC. As the outputs are open-collector, they will need a pull-up resistor tied to the + I/O supply if a high level voltage is required. The outputs are capable of sinking up to 200mA each.

The inputs can be operated between 5 and 12VDC without any external components. For voltages above 12 VDC, an external dropping resistor is required to keep the current between 1mA and 4mA. The equation for the dropping resistor's resistance in Ohms is as follows:

$$((\text{I/O supply voltage} - 1.25)/0.0025) - 3000$$

The power rating of the resistor in watts should be at least:

$$\text{Resistance} * 0.0035 * 0.0035 * 2$$

Note: The inputs can be used in two ways. They can be connected to logic levels that swing between I/O supply ground and + I/O supply, or they can be attached to a switch connected to I/O supply ground. In the second configuration, when the switch is open, the drive will see this as a logic high, when the switch is closed, and the input is connected to I/O supply ground, the drive will see this as a logic low.

Note: When an input is connected to a mechanical switch or relay, a phenomenon called "bounce" can occur. When the switch contact is almost closed, several electrical arcs can form. If an input is being used as an interrupt, each arc will be seen as a rising and falling edge, causing several false interrupts to trigger. Any input being used as an interrupt source should only be attached to solid state devices or a switch with debounce circuitry.

Digital Output Wiring Examples

