



December 5, 2011
ML0034 Document Revision E
© 2011 by Bitronics, LLC

TABLE OF CONTENTS

1.	IEC 61850 ETHERNET INTERFACE	2
1.1	Introduction	2
1.2	What is IEC 61850?	2
1.3	IEC 61850 in the Mx70 series IEDs	7
1.4	The data model of Mx70 Measurement IEDs	11
1.5	The communication services of Mx70 Measurement IEDs	11
1.6	Peer-to-peer (GSE) communications	11
1.7	Ethernet functionality	13
<hr/>		
2.	PROTOCOL IMPLEMENTATION CONFORMANCE STATEMENT (PICS)	15
2.1	Introduction	15
2.2	ACSI basic conformance statement	15
2.3	ACSI models conformance statement	16
2.4	ACSI service conformance statement	17
<hr/>		
3.	MODEL IMPLEMENTATION CONFORMANCE STATEMENT (MICS)	21
3.1	Introduction	21
3.2	Objective	21
3.3	Logical Device definitions	21
3.4	Logical Node definitions	39
3.5	Common Data Class definitions	68
3.6	Common data attribute type definitions	81
3.7	Enumerated type definitions	83
3.8	MMS data-type conversions	86
<hr/>		
4.	IEC61850 TECHNICAL ISSUES (TISSUES) CONFORMANCE STATEMENT – TIC	88
4.1	Introduction	88
4.2	Tissues considered	88
4.3	Document structure	89
4.4	Document Information (TICS)	89
4.5	Part 5 Standard	90
4.6	Part 6 Standard	91
4.7	Part 7-1 Standard	96
4.8	Part 7-2 Standard	97
4.9	Part 7-3 Standard	119
4.10	Part 7-4 Standard	124
4.11	Part 8-1 Standard	129
4.12	Part 9-1 Standard (Not supported)	135
4.13	Part 9-2 Standard (NOT SUPPORTED)	135
4.14	Part 10 Standard	136
<hr/>		
5.	PROTOCOL IMPLEMENTATION EXTRA INFORMATION FOR TESTING (PIXIT)	139
5.1	Introduction	139
5.2	Document structure	139
5.3	Application Association Model	140
5.4	Server Model	142
5.5	Data Set Model	144
5.6	Substitution Model (not supported)	145
5.7	SettingS Group Control Model (not supported)	145
5.8	Reporting Model	146
5.9	Logging Model (Not supported)	148
5.10	Generic Substation Events Model	149
5.11	Transmission of Sampled Values Model (NOT supported)	152
5.12	Control Model	152
5.13	Time and Time Synchronization	154

5.14	File Transfer Model	155
5.15	Sub-station Configuration Language	156
5.16	IED Configurator.....	156

This Bitronics 70 Series IEC 61850 Protocol Manual is made up of the following sections

INTRODUCTION	70 SERIES BACKGROUND INFORMATION
SECTION 1	IEC 61850 ETHERNET INTERFACE
SECTION 2	PROTOCOL IMPLEMENTATION CONFORMANCE STATEMENT (PICS)
SECTION 3	MODEL IMPLEMENTATION CONFORMANCE STATEMENT (MICS)
SECTION 4	TECHNICAL ISSUES (TISSUES) CONFORMANCE STATEMENT (TICS)
SECTION 5	PROTOCOL IMPLEMENTATION EXTRA INFORMATION FOR TESTING (PIXIT)

70 SERIES BACKGROUND INFORMATION

70 SERIES Firmware Version

The following table provides the most recent firmware and software versions. For best results, the Configurator version used should match with the firmware version. A complete list of firmware and software versions is provided on the 70 Series Utilities CD.

Firmware Versions						
Description	Bios Version	DSP Firmware	Host Firmware	Configurator	Utilities CD	Release Date
M870 Family						
Mx7x Product Release, New Hardware supported Dual Bus, Analog I/O	2.1/3.0*	1.210	2.050	2.31	2.43	03/24/06
Mx7x Updated Release	2.1/3.0*	"	2.060	2.32	2.44	04/14/06
Mx7x Updated Release	2.1/3.0*	1.240	2.120	2.39	2.50	10/01/06
M87x Updated Release	2.1/3.0*	1.240	2.150	2.41	2.52	12/18/06
M87x Product Release, Fault Location, Adjustable Sample Rate	3.40	1.30	2.170	2.43	2.56	12/21/07
M87x Product Release; Add Demand per phase for Watts ,VAr, & VA. Configurator & Biview improvements w/ modems. Change to Digital I/O default watchdog contact (Configurator setup; not firmware dependent). Support new version of hardware on P3x, P4x modules.	3.40	1.30	2.18	3.00A	2.57	10/17/08
M87x Product Release: Added 1mHz accuracy on M87x. Improved poll rate from 500ms to 100ms for a single P40 transducer inputs module (M87x). Fault distance configuration is changed. Time sync with respect to DNP master is changed from the DNP master jamming the time to asking the master what time to jam. Increased waveform recording limit from 999 post trigger for longer recording.	3.40	1.31	2.19	3.02	2.58	09/30/2009
M87x Product Release, IEC61850 & SNTP; Avg 3-Ph Amps and Avg 3-Ph Volts. MCL file v1.01.	3.40	1.30	3.01.0	3.01	3.01	1/30/2009

Firmware Versions						
Description	Bios Version	DSP Firmware	Host Firmware	Configurator	Utilities CD	Release Date
M87x Product Release: Added 1mHz accuracy on M87x. Improved poll rate from 500ms to 100ms for a single P40 transducer inputs module (M87x). Fault distance configuration is changed. Time sync with respect to DNP master is changed from the DNP master jamming the time to asking the master what time to jam. Increased waveform recording limit from 999 post trigger for longer recording.	3.40	1.31	3.02	3.02	3.02	09/30/2009
M87x Product Release: Added virtual I/O to DR. Added Peak Fault Current Measurement. Improved password security. Added support for control characters for SMS.	3.40	1.31	3.04	3.04	3.04	10/15/2010
M87x Product Release: Added support for dual peak current input range M872 (S16, S17), IEEE C37.232 naming convention, periodic triggering, and 4 IEC 61850 buffered reports.	3.40	1.32	3.05	3.05	3.05	2/28/2011
M87x Product Release: Increased pre- and post-trigger time on disturbance recorders, modified base memory to 1MB	3.40	1.32	3.07	3.07	3.07	11/11/11

* H10/H11

70 SERIES MANUAL SET

- ML0021 M87X User Manual
- ML0032 M57X User Manual
- ML0022 70 SERIES UCA[®] Object Model
- ML0024 70 SERIES Modbus Plus Module & Protocol
- ML0025 70 SERIES Modbus Protocol
- ML0026 70 SERIES DNP3 Protocol
- ML0027 M870D Remote Display Manual
- ML0033 M570Dx Remote Display Manual
- ML0034 70 SERIES IEC 61850[®] Protocol Manual

CERTIFICATION

Bitronics LLC certifies that the calibration of our products is based on measurements using equipment whose calibration is traceable to the United States National Institute of Standards Technology (NIST).

INSTALLATION AND MAINTENANCE

Bitronics LLC products are designed for ease of installation and maintenance. As with any product of this nature, installation and maintenance can present electrical hazards and should be performed only by properly trained and qualified personnel. If the equipment is used in a manner not specified by Bitronics LLC, the protection provided by the equipment may be impaired.

WARRANTY AND ASSISTANCE

This product is warranted against defects in materials and workmanship for a period of thirty-six (36) months from the date of their original shipment from the factory. Products repaired at the factory are likewise warranted for eighteen (18) months from the date the repaired product is shipped, or for the remainder of the product's original warranty, whichever is greater. Obligation under this warranty is limited to repairing or replacing, at our designated facility, any part or parts that our examination shows to be defective. Warranties only apply to products subject to normal use and service. There are no warranties, obligations, liabilities for consequential damages, or other liabilities on the part of Bitronics LLC except this warranty covering the repair of defective materials. The warranties of merchantability and fitness for a particular purpose are expressly excluded.

For assistance, contact Bitronics LLC at:

Phone: 610.997.5100

Fax: 610.997.5450

Email: bitronics@novatechps.com

Website: www.novatechweb.com/bitronics

Shipping:

261 Brodhead Road

Bethlehem, PA 18017-8698

USA

COPYRIGHT NOTICE

This manual is copyrighted and all rights are reserved. The distribution and sale of this manual is intended for the use of the original purchaser or his agents. This document may not, in whole or part, be copied, photocopied, reproduced, translated or reduced to any electronic medium or machine-readable form without prior consent of Bitronics LLC, except for use by the original purchaser.

The product described by this manual contains hardware and software that is protected by copyrights owned by one or more of the following entities:

Bitronics LLC, 261 Brodhead Road, Bethlehem, PA 18017;
VentureCom, Inc., Five Cambridge Center, Cambridge, MA 02142;
SISCO, Inc., 6605 192 Mile Road, Sterling Heights, MI 48314-1408;
General Software, Inc., Box 2571, Redmond, WA 98073;
Schneider Automation, Inc., One High Street, North Andover, MA 01845;
Triangle MicroWorks, Inc., 2213 Middlefield Court, Raleigh, NC 27615
Greenleaf Software Inc., Brandywine Place, Suite 100, 710 East Park Blvd, Plano, TX 75074

TRADEMARKS

The following are trademarks or registered trademarks of Bitronics, LLC:

The Bitronics logo Bitronics PowerPlex Triplex Triple-II
MultiComm PowerServe SubCycle Technology SubCycleStuf

The following are trademarks or registered trademarks of AREVA T&D Inc.:

AREVA T&D the AREVA logo MiCOM

The following are trademarks or registered trademarks of the DNP User's Group:

DNP DNP3

The following are trademarks or registered trademarks of the Electric Power Research Institute (EPRI):

UCA UCA2

The following are trademarks or registered trademarks of Schneider Automation, Inc.:

MODSOFT Modicon Modbus Plus Modbus Compact 984 PLC

The following are trademarks or registered trademarks of VentureCom, Inc.:

Phar Lap the Phar Lap logo

The following are trademarks or registered trademarks of Systems Integration Specialists Company, Inc. (SISCO):

SISCO MMS-EASE Lite AX-S4MMS

The following are trademarks or registered trademarks of General Software, Inc.:

General Software the GS logo EMBEDDED BIOS Embedded DOS

The following are trademarks or registered trademarks of the PCI Industrial Computer Manufacturers Group:

CompactPCI PICMG the CompactPCI logo the PICMG logo

SAFETY SECTION

Please refer to the M87x and M57x User Manuals, ML0021 and ML0032 respectively, for information regarding safety, installation, commissioning and decommissioning.

Section 1

IEC 61850 Ethernet Interface

1. IEC 61850 ETHERNET INTERFACE

1.1 Introduction

IEC 61850 is the international standard for Ethernet-based communication in substations. It enables integration of all protection, control, measurement and monitoring functions within a substation, and additionally provides the means for interlocking and inter-tripping. It combines the convenience of Ethernet with the security which is essential in substations today.

Bitronics has been involved in the Working Groups which formed the standard, building on experience gained with UCA2.0, the predecessor of IEC 61850. Operability of the UCA2.0 protocol is still supported for Bitronics 70 Series devices.

The 70Series measurement IEDs, models M57x and M87x, support the IEC 61850, protocol over the Ethernet interface. M57x and M87x models are designed to integrate with substation control systems (ie. Areva MiCOM protection relays integrated with PACiS substation control systems).

1.2 What is IEC 61850?

IEC 61850 is an international standard, comprised of 14 parts, which defines a communication architecture for substations.

The standard defines and offers much more than just a protocol. It provides:

- Standardized models for IEDs and other equipment within the substation
- Standardized communication services (the methods used to access and exchange data)
- Standardized formats for configuration files
- Peer-to-peer communication between devices

The standard includes mapping of data onto Ethernet. Using Ethernet in the substation offers many advantages, but most significantly, including:

- High-speed data rates (currently 100 Mbits/s, rather than 10's of kbits/s or less used by most serial protocols)
- Multiple masters (called "clients")
- Ethernet, as an open standard in every-day use

1.2.1 Interoperability

A major benefit of IEC 61850 is interoperability. IEC 61850 standardizes the data model of substation IEDs. This responds to the utilities' desire of having easier integration for different vendors' products, i.e. interoperability. It means that data is accessed in the same manner in different IEDs from either the same or different IED vendors, even though, for example, the measurement and protection algorithms of different vendors' IED (or device) types remain different.

When a device is described as IEC 61850-compliant, this does not mean that it is interchangeable, but it does mean that it is interoperable. You cannot simply replace one product with another, however the terminology is pre-defined and anyone with prior knowledge of IEC 61850 should be able to very quickly integrate a new device without the need for mapping of all of the new data. IEC 61850 will inevitably bring improved substation communications and interoperability, at a lower cost to the end user.

<p>1.2.2 Summary of 70Series IEC61850 Features (Based on part 7-2 of the IEC61850 standard)</p> <p>This table summarizes the IEC61850 features for M57x or M87x type devices.</p>	
Section 6	Server Model
	<ul style="list-style-type: none"> • 3 logical devices – Measurements, Records, Systems • 1 File Directory (of COMTRADE files)
Section 7	Association
	<ul style="list-style-type: none"> • Two Party Application Association Model – used for normal data and (non -GOOSE) reporting. Includes a simple method to inhibit writing for view-only applications • Multicast Association Model – used for GOOSE messaging
Section 8	Logical Device
	Mx7x Measurement IEDs
Section 9	Logical Nodes
	<ul style="list-style-type: none"> • 50+ Logical Nodes as defined in the Model Implementation Conformance Statement (MICS). Exact Count is dependent upon device configuration (for example, number of physical I/O points, which can vary based on the installed options) • No pre-defined datasets • 32 pre-defined URCBs (Unbuffered Report Control Blocks) in System/LLN0 • 4 pre-defined BCRBs (Buffered Report Control Blocks) in System/LLN0 • 8 pre-defined GoCB (GOOSE Control Blocks) in System/LLN0
Section 10	Data
	<ul style="list-style-type: none"> • Includes all features except access controls (however, the writability of points depends upon association parameters)
Section 11	Datasets
	<ul style="list-style-type: none"> • 26 definable datasets with FCD/FCDA capability. (A dataset consists of a named list of variables)
Section 12	Substitution
	NOT SUPPORTED in 70Series
Section 13	Settings Groups
	NOT SUPPORTED in 70Series
Section 14	Report Control Blocks (and Reports)
	<ul style="list-style-type: none"> • 32 indexed UCRBs (Unbuffered Report Control Blocks) • Power-on configurability includes cbName (control block name) and DatSet (dataset). • Dynamic configurability includes rptID (report ID), OptFlds (option fields), BufTm (buffer time), and TrgOps (trigger options). • 4 indexed BRCB (Buffered Report Control Blocks). • LCBs (Logic Control Blocks) are UNSUPPORTED • Dynamic RCBs (Report Control Blocks) are UNSUPPORTED. (new RCBs cannot be created after power-on once the configuration reboot occurs to accept the 61850 configuration).
Section 15	Generic Substation Events – GSE (and GOOSE)
	<ul style="list-style-type: none"> • 8 publishing GOOSEs (with GOOSE Control Block - GoCB) • Power-on configurability includes Control Block name (cbName), Dataset (DatSet), Application ID (AppID), Configuration Revision (confRev) and Dataset Address (DstAddress). • No Dynamic Configurability - only Report Enable (rptEna) can be changed. • 32 subscribing GOOSEs, with 32 booleans and 32 integers/ enumerations and 32 floating points (floats) populated in the internal 70Series database. • No GOOSE management capabilities (these are GetGoReference and GetGOOSEElement).
Section 16	Sampled Measured Values

NOT SUPPORTED in 70Series	
Section 17	Controls – control models
	<ul style="list-style-type: none"> • Time Activated Operate (TAO) which is “perform operation at a later time” is NOT SUPPORTED. • Operate-many configuration is supported, but can only be set up through the 70Series Configurator software tool used to set UCA configuration, not in the 61850 IED Configurator software tool. • Pulse time configuration is supported, but can only be setup through the 70Series Configurator software tool used to set UCA configuration, not in the 61850 IED Configurator software tool. • The following physical inputs are supported – status-only, direct-with-normal-security, sbo-with-normal security (including cancel). • For internal control points (other than Digital outputs), only direct-with-normal-security is supported. • Many controls are status-only (such as Mod.ctl.Val)
Section 18	Time Synchronization
	<ul style="list-style-type: none"> • Up to 2 SNTP servers using optional many-cast (or any-cast) mode of operation are supported along with configurable polling times. SNTP servers can be polled for configurable time, but only one at a time.
Section 20	Files
	<ul style="list-style-type: none"> • COMTRADE files are supported.

1.2.3 The data model

To ease understanding, the data model of any IEC 61850 IED can be viewed as a hierarchy of information. The categories and naming of this information is standardized in the IEC 61850 specification.

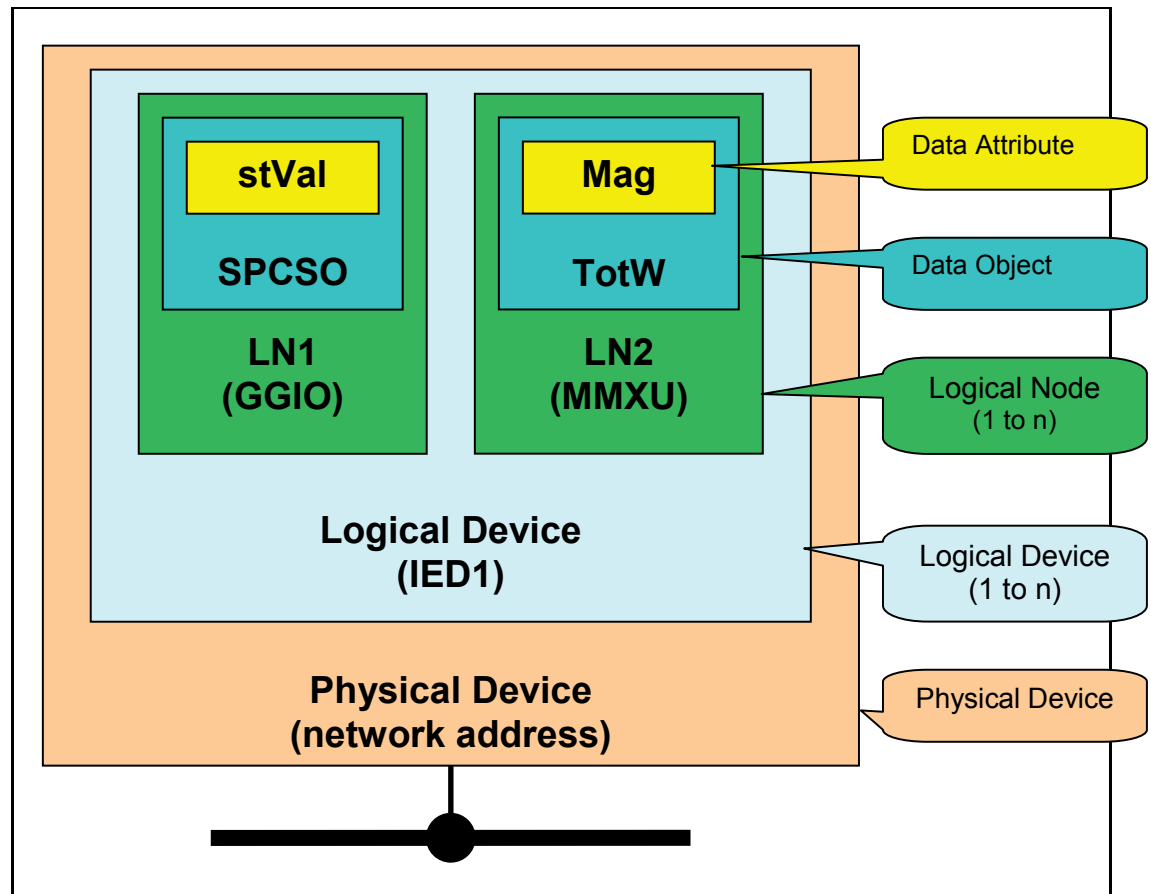

Figure 1: Data model layers in IEC 61850

The levels of this hierarchy can be described as follows:

- Physical Device
 - Identifies the actual IED within a system. Typically the device’s name or IP address can be used. (for example **Feeder_1** or **192.168.0.254**).
- Logical Device
 - Identifies groups of related Logical Nodes within the Physical Device. For the Mx70 IEDs 3 Logical Devices exist: **Measurements, Records, System**.
- Wrapper/Logical Node Instance
 - Identifies the major functional areas within the IEC 61850 data model. Either 3 or 6 characters are used as a prefix to define the functional group (wrapper) while the actual functionality is identified by a 4 character Logical Node name suffixed by an instance number. For example, GGIO1 (generic process I/O), MMXU1(measurements Bus 1), DmdMMXU1(Present thermal demands for Bus 1).

- Data Object
 - This next layer is used to identify the type of data you will be presented with. For example, **SPCSO1** (Digital output 1) of Logical Node type **GGIO**.
- Data Attribute
 - This is the actual data (measurement value, status, description, etc.). For example, **stVal** (status value) indicating actual position of the output contact for Digital output 1 for Data Object type **SPCSO1** of Logical Node type **GGIO**.

1.3 IEC 61850 in the Mx70 series IEDs

IEC 61850 can be implemented in the 70series of IEDs (M57x, M87x) only when equipped with an Ethernet option. The M87x requires an Ethernet module that is capable of supporting a 100Mb connection. For an M57x it is necessary that the instrument be equipped with a factory installed Ethernet option. The appropriate version of Host firmware and hardware defined below for 70Series devices is necessary to support the IEC 61850 protocol implementation and is required for proper operation. The 70 Series Configurator software and the IEC61850 IED Configurator software (Micom S1 Support Software) provide the Configuration tools, which manage the majority of the IEC 61850 implementation and data transfer capabilities. An MMS browser is used to view the data.

For M57x and M87x devices to be used with the IEC61850 communication protocol, here are some essential requirements that need to be met for these Mx70 devices to properly operate, namely:

- the Host board must have been manufactured with 64M RAM,
- It is necessary that the Host board has a compact Flash card installed
- The Host firmware version must be version v3.00.0 (or later) which is the version that implements the IEC 61850 communications protocol.
- The 70Series Configurator software must be the proper version in order to support:
 - Creation of new initialization (INI) files: The INI files are required in order to configure the Mx70 device. The 70Series Configurator creates these INI files and stores them on the Mx70 device in the folder "C:\Config".
 - Creation of the IED Capability Description (ICD) file: The 70 Series ICD file is an IEC61850 Substation Configuration Language (SCL) file which contains the IEC61850 'capability' description of the particular 70 Series IED. It is created by the 70 Series Configurator tool and then used by the IEC61850 IED Configurator tool to perform an IEC61850 configuration. After a new device configuration is created, the 70 Series Configurator tool automatically installs the ICD file in the "C:\Config" folder on the Mx70 device. In addition, the 70 Series Configurator places a second copy of the ICD file in a user-definable location on the local personal computer (PC) for use by the IEC61850 IED Configurator tool. This user-definable location can be set using the "File->Set Templates directory" option in the 70 Series Configurator tool menu. It is recommended this option be set to the location of the "Templates" folder used by the IEC61850 IED Configurator tool (i.e. ".\IED Configurator\Templates"). If necessary, the 70 Series Configurator tool will automatically create two sub-folders named "M57X" and "M87X" where it will place the ICD files specific to each of the M57x and M87x family of devices, respectively.
 - Creation of the MiCOM Configuration Language (MCL) file: The 70 Series MCL file, which contains the IEC61850-specific configuration of the device, is a binary file created by the IEC61850 IED Configurator tool. This tool uses the ICD file as a template from which it can create an IEC61850 device configuration. After configuration is completed and verified, the user can select "Device->Send Configuration" (CTRL+D) menu option to upload the configuration to the device. The user will then be asked to enter the IP address of the device. Two configurations are supported; 'active' and 'inactive'. The program will then prompt the user if they would like the current configuration to be made the active configuration. The two configurations correspond to the following filenames;
 - Active configuration filename - IEC61850_CONFIG.MCL
 - Inactive configuration filename - IEC61850_CONFIG.MC2

Finally, the user will be prompted if they would like the Mx70 IED to be automatically restarted. The user should answer 'yes' in order for the active bank switch to take effect during the next power cycle.

The user should also make a backup copy of their configuration. This can be done using the "File-Save" or "File->Save As" menu options which saves a backup copy of the MCL file to the local PC. It should be noted that in addition to creating 'new' IEC61850 configurations using ICD template files, the IED Configurator tool gives the user the ability to **import** and **export** the following types of IEC61850 SCL files;

- Importing -
 - Substation Configuration Description files (SCD)
 - Configured IED Description files (CID)
 - Individual IED Description files (IID)
- Exporting -
 - Configured IED Description files (CID)
 - Individual IED Description files (IID)
 - IED Configuration Description files (ICD)
 - Substation Configuration Description files (SCD)
 - Extensible Markup Language files (XML)

In order to communicate with an IEC 61850 device, it is necessary to set its Ethernet IP address. Before configuring an Mx70 device on the TCP/IP network you will need to determine the IP address for the device. An IP address is needed to enter a configuration for an Mx70 device, using the 70 Series Configurator and the IEC61850 IED Configurator software tools. The IP address can be retrieved or changed through the P1 service port (serial port) by establishing a connection through Hyperterminal. (Refer to the relevant Host section in either the M87x or M57x user manual if you need to acquaint yourself with the connection to and operation over the service port P1.) It is recommended that before establishing a TCP/IP connection that the IP address be changed from the factory default address of 192.168.0.254 to the IP address to be assigned for the IED.

A serial connection to the Mx70 device's P1 service port can be used to obtain the IP address from an Mx70 device. The service port operating with Hyperterminal allows the ip address to be retrieved and changed by typing the "ip" command. You are prompted to enter a new IP address.

During the configuration process you will enter the device's IP address. The IP address is entered starting with the 70Series Configurator while in the Identity menu page. On the Identity menu page, a radio button allows the user to select the source from which the IP address (and SNTP addressing) will be loaded. The IP address can be obtained by either loading it from the INI file or the MCL file. If any change is made to the IP address by way of the "IEC61850 IED Configurator", the IP address may not be written to the Mx70 device's IDENTITY INI file. As a result, it is possible that the 70Series Configurator Identity page may not indicate the actual IP address. It is always a good practice to determine the IP address before the configuration process is initiated.

In order to communicate with an IEC 61850 device, it is necessary to know its Ethernet address. This IP address can then be configured into either:

- An IEC 61850 "client" (or master), for example a computer or Human Machine Interface (HMI)
- An "MMS browser", with which the full data model can be retrieved from the IED. from the IED.). Note that an MMS browser, such as SISCO's MMS Object Explorer, may be required in order to browse and verify IEC 61850 objects that have been configured for the Mx70 device.

1.3.1 Capability

The IEC 61850 interface provides the following capabilities:

1. Read access to measurements

All measurands are presented using the measurement Logical Nodes, in the 'Measurements' Logical Device. Reported measurement values are refreshed by the IED once per second, in line with the IEDs user interface

2. Generation of unbuffered reports on change of status/measurement

Through the 61850 client, reports are enabled when the RptEna bit is set to a value of 1 in the Unbuffered and Buffered Report Control Blocks (URCB and BRCB). When reports are enabled, any change of state in statuses and/or measurements (which includes 'measurements' and such number-of-COMTRADE files, for example "Records/WrxRDRE1\$ST\$FltNum\$stVal", where the fault number indicates the COMTRADE file count; the COMTRADE file count is the next number to be assigned) are reported to the client. However, changes to floating-point values cannot trigger a report, but will nonetheless always be included in a report. Since Integer values have an implied deadband of 1, integer values will only be reported if there is a change in value. Unbuffered and Buffered Report Control Blocks (URCB and BRCB) can be configured in Mx70 devices by using the "IEC 61850 Configurator" tool, however the client must set the RptEna to 1 in order to enable a report to be sent to the client. For the purpose of viewing the contents of reports, an MMS browser can be used as the client performing that purpose. If using a browser such as SISCO's MMS Object Explorer, a Report Control Block (RCB) can be enabled by right clicking on the RCB (such as urcb01), selecting "Monitor Reports", then clicking on the RCB (such as urcb01) and selecting "Enable Reports".

3. Support for time synchronization over an Ethernet link

Time synchronization is supported using SNTP (Simple Network Time Protocol); this protocol is used to synchronize the internal real time clock in substation devices, (i.e., control systems, relays, IEDs). It is recommended that only one method of time synchronization be used for an Mx70 device. Time synchronization issues may be encountered if an Mx70 device operates with multiple clients that are operating from multiple protocols, which rely upon time synchronization from different time sources. The order of priority for time synchronization methods used in Mx70 devices is that IRIG-B time will take priority over UCA time, which will take priority over SNTP time. This allows a more accurate time source to be the over-riding time synchronization source for the Mx70 device.

Use care when selecting a method for time synchronization with 70Series devices when IEC 61850 protocol and DNP protocol co-exist on the same IED device: In this case, do NOT use the DNP time set command with SNTP (or any of the other time synchronization methods). A DNP set time command will override all other methods of time synchronization, which may result in a time contention between the 2 time sources, where one and then the other will set the time and time may never be able to synchronize correctly.

4. GOOSE peer-to-peer communication

GOOSE communications of statuses are included as part of the IEC 61850 protocol implementation. For more details see the section covering Peer-to-peer (GSE) communications.

5. Disturbance record extraction

Extraction of disturbance records, by file transfer, is supported. Available for extraction are the records created from the 2 Disturbance recorders and the 2 Waveform recorders in the Mx70 device. The record is extracted as an ASCII format COMTRADE file.

Setting changes are not supported in the current IEC 61850 implementation. In order to keep this process as simple as possible, such setting changes would be done using the 70Series Configurator and the "IEC61850 IED Configurator" (MiCOM S1 support software)

over the Ethernet link. A reboot of the device is necessary for the configuration to take effect after changing any of the configurable parameters for an Mx70 device.

1.3.2 IEC 61850 Configuration

One of the main objectives of IEC 61850 is to allow IEDs to be directly configured from a configuration file generated at system configuration time. At the system configuration level, the capabilities of the IED are determined from an IED capability description (ICD) file. For Mx70 devices, the ICD file is an output file generated by the 70 Series Configurator software tool. The ICD file is automatically stored in the "C:\Config" folder on the Mx70 device. In order to perform the IEC 61850 configuration of an Mx70 device, it is necessary to load the ICD file that is stored on the Mx70 device onto the hard drive of the computer on which the configuration tools were installed. It is recommended that the ICD file be stored on the user PC's hard drive under the Programs folder where the IEC61850 IED Configurator program is installed. A sub folder named "Templates" contains subfolders for M57x and M87x devices. If these subfolders do not exist it would be necessary to create them. The "61850 IED Configurator" software requires that the ICD file be loaded as an input file in order to complete the IEC 61850 configuration. Note that the 70Series Configurator should be able to automatically make and store the icd file on the PC for the user. The location where the ICD file should be stored is iedcfg\Templates and the M57x and/or M87x folders should automatically be created when the user sets iedcfg\Templates location as the desired location where the ICD file is saved. The browse function can be used from within the IED Configurator to make it easier to load the ICD file once it has been saved on the PC. The 61850 IED Configurator will produce the Micom configuration language (MCL) file which contains the IEC 61850 configuration that is loaded into the Mx70 device.

Using a collection of these ICD files from varying products, the entire protection and measurement function of a substation can be designed, configured and tested (using simulation tools) before the product is even installed into the substation.

To aid in this process, the 61850 IED Configurator software tool (included on the CD as MiCOM S1 Studio Support Software) allows the pre-configured IEC 61850 configuration file (an SCD file or CID file) to be imported and transferred to the IED. Alongside this, the requirements of entering a configuration manually are satisfied by allowing the manual creation of configuration files for M57x and M87x devices based on their original IED capability description (ICD) file.

Other features include the extraction of configuration data for viewing and editing, and a sophisticated error checking sequence which ensures that the configuration data is valid for sending to the IED and that the IED will function within the context of the substation.

1.3.2.1 Configuration Banks

To promote version management and minimize down-time during system upgrades and maintenance, the Mx70 devices utilize a storage mechanism consisting of multiple configuration banks. These configuration banks are categorized as:

- Active Configuration Bank (MCL file stored in E:\Config on Mx70 device)
- Inactive Configuration Bank (MC2 file is previous configuration file stored in E:\Config on Mx70 device)

Any new configuration to the Mx70 device will be automatically stored into the inactive configuration bank, therefore not immediately affecting the current configuration

When the upgrade or maintenance stage is complete, the 61850 IED Configurator tool will prompt the user to make the configuration (to a single IED) active. A reboot of the Mx70 device is necessary in order for the configuration to be activated, authorizing the activation of the new configuration contained in the inactive configuration bank, by switching the active and inactive configuration banks. This technique ensures that the system down-time is minimized while enabling the new configuration.

1.3.2.2 Network connectivity

Note: This section presumes a prior knowledge of IP addressing and related topics. Further details on this topic may be found on the Internet (search for IP Configuration) and in numerous relevant books.

Configuration of the relay IP parameters (IP Address, Subnet Mask, Gateway) and SNTP time synchronization parameters (SNTP Server 1, SNTP Server 2, and polling interval) is performed by the IED Configurator tool, so if these parameters are not available via an SCL file, they must be configured manually.

If the assigned IP address is duplicated elsewhere on the same network, the remote communications will operate in an indeterminate way. However, a check is performed for a conflict on every IP configuration change and at power up. The Mx70 allows other devices to perform duplicate IP address detection.

An Mx70 device can be configured to accept data from networks other than the local network by using the 'Gateway' setting.

1.4 The data model of Mx70 Measurement IEDs

The data model naming convention, which was adopted in the M57x and M87x Measurement IEDs, has been standardized for consistency. Hence the Logical Nodes are allocated to one of the three Logical Devices, Measurements, Records, or Systems as appropriate, and the wrapper names used to instantiate Logical Nodes will remain consistent between the M57x and M87x measuring IEDs

The data model is described in the Model Implementation Conformance Statement (MICS) document, which is available as a separate section of this IEC 61850 user manual. The MICS document provides lists of Logical Device definitions, Logical Node definitions, Common Data Class and Attribute definitions, Enumeration definitions, and MMS data type conversions. It generally follows the format used in Parts 7-3 and 7-4 of the IEC 61850 standard.

1.5 The communication services of Mx70 Measurement IEDs

The IEC 61850 communication services which are implemented in the M57x and M87x IEDs are described in the Protocol Implementation Conformance Statement (PICS) document, which is available within a separate section of this IEC 61850 user manual. The PICS document provides the Abstract Communication Service Interface (ACSI) conformance statements as defined in Annex A of Part 7-2 of the IEC 61850 standard.

1.6 Peer-to-peer (GSE) communications

The implementation of IEC 61850 with respect to Generic Substation Events (GSE) sets the way for cheaper and faster inter-device communications amongst control systems, relays and IEDs. The generic substation event model provides the possibility for a fast and reliable system-wide distribution of input and output data values. The generic substation event model is based on the concept of an autonomous decentralization, providing an efficient method allowing the simultaneous delivery of the same generic substation event information to more than one physical device through the use of multicast services.

The use of multicast messaging means that IEC 61850 GOOSE uses a publisher-subscriber system to transfer information around the network*.

Note: * Multicast messages cannot be routed across networks without specialized equipment.

When a device detects a change in one of its monitored status points it publishes (i.e. sends) a new message. Any device that is interested in the information subscribes (i.e. listens) to the data it contains.

Each new message is re-transmitted at user-configurable intervals until the maximum interval is reached, in order to overcome possible corruption due to interference, and congestion.

1.6.1 Scope (GOOSE messages)

In the Mx70 device database, a maximum of 32 GOOSE binary inputs, 32 GOOSE integer inputs, and 32 GOOSE float (floating point) inputs are available to be mapped directly up to a published dataset in a GOOSE message. All Mx70 published GOOSE signals may contain BOOLEAN, Integer, and Float values. These signals are referred to by the following names:

- GOOSE Binary Input - Ind#, where # will be a number between 1-32,
- GOOSE Integer Input - IntIn#, where # will be a number between 1-32,
- GOOSE Analog Input - AnIn# (floating point), where # will be a number between 1-32,

These inputs for a GOOSE message would be mapped in the IEC61850 IED Configurator. The 61850 IED Configurator tool is used to configure GOOSE publishing and GOOSE subscribing. It is only possible to publish a GOOSE from System/LLN0 in the "IEC61850 IED Configurator". To subscribe to a GOOSE, use System/GosGGIO1 to configure the GOOSE from the "IEC61850 IED Configurator" tool.

Each GOOSE signal contained in a subscribed GOOSE message can be mapped to any of the 32 GOOSE binary inputs, 32 GOOSE integer inputs, and 32 GOOSE float inputs. These virtual inputs used by the GOOSE message allow the mapping to internal logic functions for protection control, directly to output contacts, or to LEDs for monitoring.

Once the binary, integer, and analog points are mapped in a particular application a GOOSE message should be usable in order to cause trigger conditions for other devices (e.g. cross triggering between Mx70 devices), where a 2nd IED is configured by programming a trigger condition expected to be contained in the dataset received in a GOOSE message. When the trigger occurs (such as a binary state change) a GOOSE message results, containing a dataset that can be mapped to the 2nd IEDs GOOSE inputs (either the binary inputs, integer inputs, or analog floating point inputs) and used to trigger that IED on the network, based on the values or measurements contained in the dataset

The Mx70 IEDs can subscribe to all GOOSE messages but only the following data types can be decoded and mapped to the inputs (binary, integer, and float) supported by the GOOSE.

- BOOLEAN
- BSTR2
- INT16
- INT32
- INT8
- INT16U
- INT32U
- INT8U
- FLOAT32
- SPS
- DPS

1.6.2 IEC 61850 GOOSE configuration

All GOOSE configurations are performed via the IED Configurator tool available within the 61850 IED Configurator software tool (available from MiCOM S1 Studio Support Software).

All GOOSE publishing configuration can be found under the 'GOOSE Publishing' tab in the configuration editor window. All GOOSE subscription configurations can be found under the 'External Binding' tab in the configuration editor window. Care should be taken to ensure that the configuration is correct, to ensure efficient GOOSE scheme operation.

The set up (programming of trigger conditions to allow an Mx70 device to be cross triggered from another device's dataset received as a GOOSE message is a typical distributed recorder application for Mx70 devices in a substation.

1.7 Ethernet functionality

1.7.1 Ethernet disconnection

IEC 61850 'associations' are unique and made to the IED between the client (master) and server (IEC 61850 device). In the event that the Ethernet is disconnected, such associations are lost, and will need to be re-established by the client. The TCP_KEEPALIVE function is implemented in Mx70 devices to monitor each association, and terminate any which are no longer active.

1.7.2 Loss of power

Mx70 devices allow the re-establishment of associations by the client without a negative impact on the IED's operation after having its power removed. As the Mx70 device acts as a server in this process, the client must request the association. When power is lost, reports requested by connected clients are reset and must be re-enabled by the client when it next creates the new association to the IED.

Section 2 PICS

Protocol Implementation Conformance Statement

2. PROTOCOL IMPLEMENTATION CONFORMANCE STATEMENT (PICS)

2.1 Introduction

This specification is the **Protocol Implementation Conformance Statement (PICS)** and presents the ACSI conformance statements as defined in Annex A of Part 7-2 of the IEC 61850 standard specifications.

The 70 Series IEC61850 implementation shall conform to the Protocol Implementation Conformance Statement below:

\

2.2 ACSI basic conformance statement

The basic conformance statement shall be as defined in Table A.1.

Table A.1 - Basic conformance statement

		Client/ Subscriber		Server/ Publisher		Value/Comments
Client-Server roles						
B11	Server side (of TWO-PARTY-APPLICATION-ASSOCIATION)	—	—	c1	Y	
B12	Client side of (TWO-PARTY-APPLICATION-ASSOCIATION)	c1	N	—	—	
SCSMs supported						
B21	SCSM: IEC 61850-8-1 used		N		Y	
B22	SCSM: IEC 61850-9-1 used				N	
B23	SCSM: IEC 61850-9-2 used				N	
B24	SCSM: other				N	
Generic substation event model (GSE)						
B31	Publisher side	—	—	O	Y	
B32	Subscriber side	O	Y	—	—	
Transmission of sampled value model (SVC)						
B41	Publisher side	—	—	O	N	
B42	Subscriber side	O	N	—	—	
c1 – shall be 'M' if support for LOGICAL-DEVICE model has been declared. O – Optional M – Mandatory Y – Yes (supported) N – No (not supported)						

2.3 ACSI models conformance statement

The ACSI models conformance statement shall be as defined in Table A.2.

Table A.2 - ACSI models conformance statement

		Client/ Subscriber		Server/ Publisher		Value/Comments
If Server side (B1) supported						
M1	Logical device	c2	N	c2	Y	
M2	Logical node	c3	N	c3	Y	
M3	Data	c4	N	c4	Y	
M4	Data set	c5	N	c5	Y	
M5	Substitution	O	N	O	N	
M6	Setting group control	O	N	O	N	
	Reporting					
M7	Buffered report control	O	N	O	Y	
M7-1	sequence-number				Y	
M7-2	report-time-stamp				Y	
M7-3	reason-for-inclusion				Y	
M7-4	data-set-name				Y	
M7-5	data-reference				Y	
M7-6	buffer-overflow				Y	
M7-7	entryID				Y	
M7-8	BufTim				Y	
M7-9	IntgPd				Y	
M7-10	GI				Y	
M7-11	conf-revision (revision 2 adds this row entry)					
M8	Unbuffered report control	O	N	O	Y	
M8-1	sequence-number				Y	
M8-2	report-time-stamp				Y	
M8-3	reason-for-inclusion				Y	
M8-4	data-set-name				Y	
M8-5	data-reference				Y	
M8-6	BufTim				Y	
M8-7	IntgPd				Y	
M8-8	GI				Y	
M8-9	conf-revision (revision 2 adds this row entry)					
	Logging	O	N	O	N	
M9	Log control	O	N	O	N	
M9-1	IntgPd		N		N	
M10	Log	O	N	O	N	
M11	Control	M	N	M	Y	
If GSE (B31/32) is supported						
M12	GOOSE	O	Y	O	Y	
M12-1	entryID (revision 2 removes this row entry)				N	
M12-2	DataRefInc (revision 2 removes this row entry)				N	
M13	GSSE	O	Y	O	Y	
If SVC (B41/42) is supported						

		Client/ Subscriber		Server/ Publisher		Value/Comments
M14	Multicast SVC	O	N	O	N	
M15	Unicast SVC	O	N	O	N	
M16	Time	M	Y	M	N	Time source with required accuracy shall be available
M17	File Transfer	O	N	O	Y	
c2 – shall be 'M' if support for LOGICAL-NODE model has been declared c3 – shall be 'M' if support for DATA model has been declared c4 – shall be 'M' if support for DATA-SET , Substitution, Report, Log Control, or Time model has been declared c5 – shall be 'M' if support for Report, GSE, or SMV models has been declared						

2.4 ACSI service conformance statement

The ACSI service conformance statement shall be as defined in Table A.3 (depending on the statements in Table A.1).

Table A.3 - ACSI service conformance statement

	Services	AA: TP/MC	Client/ Subscriber		Server/ Publisher		Comments
Server (clause 6)							
S1	ServerDirectory	TP		N	M	Y	
Application association (clause 7)							
S2	Associate		M	N	M	Y	
S3	Abort		M	N	M	Y	
S4	Release		M	N	M	Y	
Logical device (clause 8)							
S5	LogicalDeviceDirectory	TP	M	N	M	Y	
Logical node (clause 9)							
S6	LogicalNodeDirectory	TP	M	N	M	Y	
S7	GetAllDataValues	TP	O	N	M	Y	
Data (clause 10)							
S8	GetDataValues	TP	M	N	M	Y	
S9	SetDataValues	TP	O	N	O	Y	
S10	GetDataDirectory	TP	O	N	M	Y	
S11	GetDataDefinition	TP	O	N	M	Y	
Data set (clause 11)							
S12	GetDataSetValues	TP	O	N	M	Y	
S13	SetDataSetValues	TP	O	N	O	N	
S14	CreateDataSet	TP	O	N	O	N	
S15	DeleteDataSet	TP	O	N	O	N	
S16	GetDataSetDirectory	TP	O	N	O	Y	
Substitution (clause 12)							
S17	SetDataValues	TP	M	N	M	N	

	Services	AA: TP/MC	Client/ Subscriber		Server/ Publisher		Comments
--	----------	--------------	-----------------------	--	----------------------	--	----------

Setting group control (clause 13)							
S18	SelectActiveSG	TP	O	N	O	N	
S19	SelectEditSG	TP	O	N	O	N	
S20	SetSGValues	TP	O	N	O	N	
S21	ConfirmEditSGValues	TP	O	N	O	N	
S22	GetSGValues	TP	O	N	O	N	
S23	GetSGCBValues	TP	O	N	O	N	

Reporting (clause 14)							
Buffered report control block (BRCB)							
S24	Report	TP	c6	N	c6	Y	
S24-1	data-change (dchg)					Y	
S24-2	qchg-change (qchg)					Y	
S24-3	data-update (dupd)					N	
S25	GetBRCBValues	TP	c6	N	c6	Y	
S26	SetBRCBValues	TP	c6	N	c6	Y	
Unbuffered report control block (URCB)							
S27	Report	TP	c6	N	c6	Y	
S27-1	data-change (dchg)			N		Y	
S27-2	qchg-change (qchg)			N		Y	
S27-3	data-update (dup)			N		N	
S28	GetURCBValues	TP	c6	N	c6	Y	
S29	SetURCBValues	TP	c6	N	c6	Y	
c6 – shall declare support for at least one (BRCB or URCB)							

Logging (clause 14)							
Log control block							
S30	GetLCBValues	TP	M	N	M	N	
S31	SetLCBValues	TP	O	N	M	N	
Log							
S32	QueryLogByTime	TP	c7	N	M	N	
S33	QueryLogAfter	TP	c7	N	M	N	
S34	GetLogStatusValues	TP	M	N	M	N	
c7 – shall declare support for at least one (QueryLogByTime or QueryLogByEntry)							

Generic substation event model (GSE) (clause 14.3.5.3.4)							
GOOSE-CONTROL-BLOCK							
S35	SendGOOSEMessage	MC	c8	N	c8	Y	
S36	GetGoReference	TP	O	N	c9	N	
S37	GetGOOSEElementNumber	TP	O	N	c9	N	
S38	GetGoCBValues	TP	O	N	O	N	
S39	SetGoCBValues	TP	O	N	O	N	
GSSE-CONTROL-BLOCK							
S40	SendGSSEMessage	MC	c8	N	c8	Y	
S41	GetGsReference	TP	O	N	c9	N	
S42	GetGSSEElementNumber	TP	O	N	c9	N	

	Services	AA: TP/MC	Client/ Subscriber		Server/ Publisher		Comments
S43	GetGsCBValues	TP	O	N	O	N	
S44	SetGsCBValues	TP	O	N	O	N	
c8 – shall declare support for at least one (SendGOOSEMessage or SendGSSEMessage) c9 – shall declare support if TP association is available							

Transmission of sampled value model (SVC) (clause 16)							
Multicast SVC							
S45	SendMSVMessage	MC	c10	N	c10	N	
S46	GetMSVCBValues	TP	O	N	O	N	
S47	SetMSVCBValues	TP	O	N	O	N	
Unicast SVC							
S48	SendUSVMessage	TP	c10	N	c10	N	
S49	GetUSVCBValues	TP	O	N	O	N	
S50	SetUSVCBValues	TP	O	N	O	N	
c10 – shall declare support for at least one (SendMSVMessage or SendUSVMessage)							

Control (clause 17.5.1)							
S51	Select		M	N	O	Y	
S52	SelectWithValue	TP	M	N	O	Y	
S53	Cancel	TP	O	N	O	Y	
S54	Operate	TP	M	N	M	Y	
S55	Command-Termination	TP	M	N	O	N	
S56	TimeActivated-Operate	TP	O	N	O	N	

File transfer (clause 20)							
S57	GetFile	TP	O	N	M	Y	
S58	SetFile	TP	O	N	O	N	
S59	DeleteFile	TP	O	N	O	N	
S60	GetFileAttributeValues	TP	O	N	M	Y	

Time (5.5)					
T1	Time resolution of internal clock			20 (1µs)	nearest negative power of 2 in seconds
T2	Time accuracy of internal clock			10 (1ms)	T0
					T1
					T2
					T3
					T4
					T5
T3	supported TimeStamp resolution	-		20 (1µs)	Nearest value of 2 ^{**n} in seconds according to 5.5.3.7.3.3

Section 3 MICS

Model Implementation Conformance Statement

3. MODEL IMPLEMENTATION CONFORMANCE STATEMENT (MICS)

3.1 Introduction

This specification is the Model Implementation Conformance Statement (MICS) and presents the top-level IEC61850 data model that has been implemented. The definitions of all used Logical Nodes and their associated Common Data Classes, components and associated enumerated values are also included for completeness.

The reader is expected to be conversant with the terminology presented within the IEC61850 part 7 series of specifications.

3.2 Objective

To provide comprehensive details of the standard data object model elements supported by each one of the logical devices - M571, M572 (Dual Feeder), M572 (Breaker & ½), M871, M872 (Dual Feeder), and M872 (Breaker & ½). The MICS is conformant to the devices associated ICD (Substation Configuration Language) file, according to part 6 of the IEC61850 standards. The layout of the presented tables within this document are conformant to the part 7 series of the IEC61850 standard specifications with the following exceptions:

- The "Trigger Options" field is not presented within the data object tables.
- The "M/O" (Mandatory/Optional) field is not present in the data object tables, as the definitions are as deployed within the models
- An additional column "X" is used to signify Bitronics custom objects or attributes

3.3 Logical Device definitions

The Mx70 IEDs implement an IEC61850 server that can contain one or more Logical Devices. Each Logical Device contains a data model built from instances of specific Logical Nodes and must consist of at least an instance of the LPHD Logical Node (which is responsible for providing physical device information) and an instance of the LLN0 Logical Node (for addressing common issues across the Logical Device).

The IEC61850 data model is contained within the Logical Devices detailed in the table below. All Bitronics devices will name the supported Logical Devices consistently to ensure that data model variables with the same purpose will have the same name within each Bitronics server.

Logical Device	Comment/Usage
Control	This Domain is not used in any of the Mx70 Logical Devices
Measurements	Mx70 Series Measurements Domains: Measurement Domains are used for each Measurements Logical Devices. The following list indicates the 6 types of 70 Series Measurements Logical devices possible: M571, M572 Dual Feeder, M572 Breaker & ½ M871, M872 Dual Feeder, M872 Breaker & ½
Protection	This Domain is not used in any of the Mx70 Logical Devices
Records	Mx70 Series Records Domain for the Measurements Logical Devices: M571, M572 Dual Feeder, M572 Breaker & ½ M871, M872 Dual Feeder, M872 Breaker & ½
System	Mx70 Series Systems Domains for the Measurement Logical Devices: M571, M572 Dual Feeder, M572 Breaker & ½ M871, M872 Dual Feeder, M872 Breaker & ½

3.3.1 IEC61850 logical device data model

The IEC61850 Logical Device top-level data model consists of instances of Logical Nodes. The data model name for a Logical Node instance is constructed from an optional prefix (known as the wrapper), the Logical Node name, and an instance ID (or suffix).

The data models for each of the logical devices are presented in this document. The logical order is used to describe each of the physical devices. However, when it comes to the data objects, data attributes and enumeration tables these are alphabetically sorted so that searching is made easier.

The following Tables indicate the Logical Node Description Lists. The “LN Types” that are used for all Mx70 measurement products are found in Tables 1-6. It is necessary to use the “LN Types” indicated to create the mapping necessary for the “LN Instance”. There are tables for each of the following: M571, M572 Dual Feeder, M572 Breaker & ½, M871, M872 Dual Feeder, and M872 Breaker & ½. LN Type is remapped to LN Instance in order to define each Logical Node per the standard, IEC61850 Part 7. Tables 1-6 define the logical devices, while table 7 defines the “LN Types”.

Note 1 (applies for M87x tables 4-6): GGIOx - The GGIO suffix number indicated by x in the LN instance name represents the logical slot number that has been configured through the 70Series Configurator. A maximum number of 7 times the number of logical nodes are possible with an M87x due to the logical slot configuration for LN Instance. It is possible for the GGIO logical slots to range from 1 through 7 for M87x. (i.e. GGIO1-GGIO7), which differs from M57x where the number of logical slots is fixed at 1 (i.e. GGIO1).

During Configuration, Digital I/O slot numbers 0-6 map to logical slots GGIO1-GGIO7. Transducer (Analogue) Input slot numbers 1-7 map to logical slots GGIO1-GGIO7. For Digital I/O modules, P30 and P31, the slot numbers 0-6 must be incremented by 1 to obtain the GGIOx logical slot number, however for Transducer Input module P40 the assigned slot number is the GGIO logical slot number. For example if two Digital I/O modules are assigned to logical slot numbers 0 and 2 and one Transducer (Analogue) Input module is assigned logical slot 3, then GGIO1 would consist of one Digital I/O module, while GGIO3 would consist of 1 Digital I/O and 1 Transducer input module. However, if the two Digital I/O modules are assigned to logical slot numbers 0 and 3 and the (Analogue) Transducer Input module is assigned logical slot 3, then GGIO1 would consist of one Digital I/O module, GGIO3 would consist of 1 Transducer input module, and GGIO4 would consist of 1 Digital I/O module.

For M87x models the total number of logical slots will depend upon the chassis size, the number of slots that can be assigned for GGIO, and whether the digital and analogue are grouped together (such as P30+P40 grouped together to represent one logical node) or kept separate.

Table 1 – M571

LD	LN Instance	LN Type	Description
Measurements			
	LLN0	LLN0_0	Measurements Logical Device
	LPHD	LPHD_0	Physical Device Information
	MMXU1	MMXU_10	M571 Bus 1 (V,A,W,VAr) Measurements (LN is extended to include custom measurements)
	MMXU2	MMXU_11	M571 Bus 2 (V) Measurements (LN is extended to include custom measurements)
	FndMMXU1	MMXU_7	Fundamental of Bus 1 (MMXU1) Measurements
	FndMMXU2	MMXU_8	Fundamental of Bus 2 (MMXU2) Measurements
	DmdMMXU1	MMXU_1	Present Thermal Demands of Bus 1 (MMXU1) Measurements
	DmdMMXU2	MMXU_2	Present Thermal Demands of Bus 2 (MMXU2) Measurements
	DmnMMXU1	MMXU_3	Minimum Thermal Demands of Bus 1 (MMXU1)
	DmnMMXU2	MMXU_2	Minimum Thermal Demands of Bus 2 (MMXU2)
	DmxMMXU1	MMXU_1	Maximum Thermal Demands of Bus 1 (MMXU1)
	DmxMMXU2	MMXU_2	Maximum Thermal Demands of Bus 2 (MMXU2)
	FndDmdMMXU1	MMXU_5	Fundamental Thermal Demands of Bus 1 (MMXU1)
	FndDmxMMXU1	MMXU_5	Fundamental Maximum Thermal Demands of Bus 1 (MMXU1)
	MMTR1	MMTR_0	Bus 1 Energy Metering Measurement (LN is extended to include custom measurements)
	MSQI1	MSQI_0	Bus 1 Sequence Components (Volts & Amps)
	MSQI2	MSQI_1	Bus 2 Sequence Components (Volts only)
	MHAI1	MHAI_2	Bus 1 Harmonics (Volts & Amps) including individual harmonics, phase related K factor and harmonic demand (LN is extended to include custom measurements)
	MHAI2	MHAI_3	Bus 2 Harmonics (Volts only) including individual harmonics and harmonic demand (LN is extended to include custom measurements)
	DmdMHAI1	MHAI_0	Present Thermal Demands for Bus 1 (MHAI1)
	DmdMHAI2	MHAI_1	Present Thermal Demands for Bus 2 (MHAI2) - Volts only
	DmnMHAI1	MHAI_1	Minimum Thermal Demands for Bus 1 (MHAI1) -No minimum Amp demands
	DmnMHAI2	MHAI_1	Minimum Thermal Demands for Bus 2 (MHAI2) - Volts only
	DmxMHAI1	MHAI_0	Maximum Thermal Demands for Bus 1 (MHAI1)
	DmxMHAI2	MHAI_1	Maximum Thermal Demands for Bus 2 (MHAI2) - Volts only
	MLFK1	MLFK_0	Voltage Flicker Bus 1 Measurement (Custom LN)
	MLFK2	MLFK_0	Voltage Flicker Bus 2 Measurement (Custom LN)
	MSYN1	MSYN_0	Synch check Bus1 to Bus 2 Phase A (Custom LN)
	MSYN2	MSYN_0	Synch check Bus1 to Bus 2 Phase B (Custom LN)
	MSYN3	MSYN_0	Synch check Bus1 to Bus 2 Phase C (Custom LN)
	MADV1	MADV_0	Advanced Measurements Bus 1 (Custom LN)

LD	LN Instance	LN Type	Description
Measurements			
	MFLO1	MFLO_0	Fault Distance Measurement Bus 1 (Custom LN)
	MTMP1	MTMP_0	Temperature Measurement - internal ambient (Custom LN)
Records			
	LLN0	LLN0_0	Records Logical Device
	LPHD	LDHD_0	Physical Device Information
	WrxRDRE1	RDRE_0	Waveform Recorder 1
	WrxRDRE2	RDRE_0	Waveform Recorder 2
	DrxRDRE1	RDRE_0	Disturbance Recorder 1
	DrxRDRE2	RDRE_0	Disturbance Recorder 2
System			
	LLN0	LLN0_1	System Logical Device Can only Publish GOOSE in System/LLN0
	LPHD	LPHD_0	Physical Device Information
	GosGGIO1	GGIO_8	GOOSE Input Status (GOOSE Subscriptions are done here)
	TVTR1	TVTR_0	Voltage Transformer Phase A Bus 1
	TVTR2	TVTR_0	Voltage Transformer Phase B Bus 1
	TVTR3	TVTR_0	Voltage Transformer Phase C Bus 1
	TVTR4	TVTR_0	Voltage Transformer Phase N Bus 1
	TVTR5	TVTR_0	Voltage Transformer Phase A Bus 2
	TVTR6	TVTR_0	Voltage Transformer Phase B Bus 2
	TVTR7	TVTR_0	Voltage Transformer Phase C Bus 2
	TVTR8	TVTR_0	Voltage Transformer Phase N Bus 2
	TCTR1	TCTR_0	Current Transformer Phase A Bus 1
	TCTR2	TCTR_0	Current Transformer Phase B Bus 1
	TCTR3	TCTR_0	Current Transformer Phase C Bus 1
I/O Options (GGIO Logical slot number is fixed at 1).			
Choose option based on logical slot configuration	No GGIO option	No GGIO option	No generic Process I/O
Choose option based on logical slot configuration	GGIO1	GGIO_0	Generic Process I/O GGIO for M57x : 4DI/4DO
Choose option based on logical slot configuration	GGIO1	GGIO_3	Generic Process I/O GGIO for M57x : 4DI/4DO/4AI
Choose option based on logical slot configuration	GGIO1	GGIO_6	Generic Process I/O GGIO for M57x : /4AI
	GGIO2	GGIO_9	Generic Process I/O – 32 Virtual Output signals

Table 2 – M572 Dual Feeder

LD	LN Instance	LN Type	Description
Measurements			
	LLN0	LLN0_0	Measurements Logical Device
	LPHD	LPHD_0	Physical Device Information
	MMXU1	MMXU_10	M572 Bus 1 (V,A,W,VAr) Measurements (LN is extended to include custom measurements)
	MMXU2	MMXU_10	M572 Bus 2 (V,A,W,VAr) Measurements (LN is extended to include custom measurements)
	MMXN1	MMXN_0	M572 Dual Feeder Voltage Reference 1 (V)
	MMXN2	MMXN_0	M572 Dual Feeder Voltage Reference 2 (V)
	FndMMXU1	MMXU_7	Fundamental of Bus 1 (MMXU1) Measurements
	FndMMXU2	MMXU_7	Fundamental of Bus 2 (MMXU2) Measurements
	DmdMMXU1	MMXU_1	Present Thermal Demands of Bus 1 (MMXU1) Measurements
	DmdMMXU2	MMXU_1	Present Thermal Demands of Bus 2 (MMXU2) Measurements
	DmnMMXU1	MMXU_3	Minimum Thermal Demands of Bus 1 (MMXU1)
	DmnMMXU2	MMXU_3	Minimum Thermal Demands of Bus 2 (MMXU2)
	DmxMMXU1	MMXU_1	Maximum Thermal Demands of Bus 1 (MMXU1)
	DmxMMXU2	MMXU_1	Maximum Thermal Demands of Bus 2 (MMXU2)
	FndDmdMMXU1	MMXU_5	Fundamental Thermal Demands of Bus 1 (MMXU1)
	FndDmdMMXU2	MMXU_5	Fundamental Thermal Demands of Bus 2 (MMXU2)
	FndDmxMMXU1	MMXU_5	Fundamental Maximum Thermal Demands of Bus 1 (MMXU1)
	FndDmxMMXU2	MMXU_5	Fundamental Maximum Thermal Demands of Bus 2 (MMXU2)
	MMTR1	MMTR_0	Bus 1 Energy Metering Measurement (LN is extended to include custom measurements)
	MMTR2	MMTR_0	Bus 2 Energy Metering Measurement (LN is extended to include custom measurements)
	MSQI1	MSQI_0	Bus 1 Sequence Components (Volts & Amps)
	MSQI2	MSQI_0	Bus 2 Sequence Components (Volts & Amps)
	MHAI1	MHAI_2	Bus 1 Harmonics (Volts & Amps) including individual harmonics, phase related K factor and harmonic demand (LN is extended to include custom measurements)
	MHAI2	MHAI_2	Bus 2 Harmonics (Volts & Amps) including individual harmonics, phase related K factor and harmonic demand (LN is extended to include custom measurements)
	DmdMHAI1	MHAI_0	Present Thermal Demands for Bus 1 (MHAI1)
	DmdMHAI2	MHAI_0	Present Thermal Demands for Bus 2 (MHAI2)
	DmnMHAI1	MHAI_1	Minimum Thermal Demands for Bus 1 (MHAI1) - (No minimum Amp demands)
	DmnMHAI2	MHAI_1	Minimum Thermal Demands for Bus 2 (MHAI2) - No minimum Amp demands
	DmxMHAI1	MHAI_0	Maximum Thermal Demands for Bus 1 (MHAI1)
	DmxMHAI2	MHAI_0	Maximum Thermal Demands for Bus 2 (MHAI2)

LD	LN Instance	LN Type	Description
Measurements			
	MLFK1	MLFK_0	Voltage Flicker Bus 1 Measurement (Custom LN)
	MLFK2	MLFK_0	Voltage Flicker Bus 2 Measurement (Custom LN)
	MSYN1	MSYN_0	Synch check Bus 1 Phase A to VREF1 for M572 (Dual Feeder) (Custom LN)
	MSYN2	MSYN_0	Synch check Bus 1 Phase B to VREF1 (Custom LN)
	MSYN3	MSYN_0	Synch check Bus 1 Phase C to VREF1 (Custom LN)
	MSYN4	MSYN_0	Synch check Bus 1 Phase A to VREF2 (Custom LN)
	MSYN5	MSYN_0	Synch check Bus 1 Phase B to VREF2 (Custom LN)
	MSYN6	MSYN_0	Synch check Bus 1 Phase C to VREF2 (Custom LN)
	MADV1	MADV_0	Advanced Measurements Bus 1 (Custom LN)
	MADV2	MADV_0	Advanced Measurements Bus 2 (Custom LN)
	MFLO1	MFLO_0	Fault Distance Measurement Bus 1 (Custom LN)
	MFLO2	MFLO_0	Fault Distance Measurement Bus 2 (Custom LN)
	MTMP1	MTMP_0	Temperature Measurement – Internal ambient (Custom LN)
Records			
	LLN0	LLN0_0	Records Logical Device
	LPHD	LDHD_0	Physical Device Information
	WrxRDRE1	RDRE_0	Waveform Recorder 1
	WrxRDRE2	RDRE_0	Waveform Recorder 2
	DrxRDRE1	RDRE_0	Disturbance Recorder 1
	DrxRDRE2	RDRE_0	Disturbance Recorder 2
System			
	LLN0	LLN0_1	System Logical Device Can only Publish GOOSE in System/LLN0
	LPHD	LPHD_0	Physical Device Information
	GosGGIO1	GGIO_8	GOOSE Input Status (GOOSE Subscriptions are done here)
	TVTR1	TVTR_0	Voltage Transformer Phase A Bus 1
	TVTR2	TVTR_0	Voltage Transformer Phase B Bus 1
	TVTR3	TVTR_0	Voltage Transformer Phase C Bus 1
	TVTR4	TVTR_0	Voltage Transformer Phase N Bus 1
	TVTR5	TVTR_0	Voltage Transformer Phase A Bus 2
	TVTR6	TVTR_0	Voltage Transformer Phase B Bus 2
	TVTR7	TVTR_0	Voltage Transformer Phase C Bus 2
	TVTR8	TVTR_0	Voltage Transformer Phase N Bus 2
	TVTR9	TVTR_0	Voltage Transformer for Vref1
	TVTR10	TVTR_0	Voltage Transformer for Vref2
	TCTR1	TCTR_0	Current Transformer Phase A Bus 1

	TCTR2	TCTR_0	Current Transformer Phase B Bus 1
	TCTR3	TCTR_0	Current Transformer Phase C Bus 1
	TCTR5	TCTR_0	Current Transformer Phase A Bus 2
	TCTR6	TCTR_0	Current Transformer Phase B Bus 2
	TCTR7	TCTR_0	Current Transformer Phase C Bus 2
System I/O Options (GGIO Logical slot number is fixed at 1).			
Choose option based on logical slot configuration	No GGIO option	No GGIO option	No generic Process I/O
Choose option based on logical slot configuration	GGIO1	GGIO_0	Generic Process I/O GGIO for M57x : 4DI/4DO
Choose option based on logical slot configuration	GGIO1	GGIO_3	Generic Process I/O GGIO for M57x : 4DI/4DO/4AI
Choose option based on logical slot configuration	GGIO1	GGIO_6	Generic Process I/O GGIO for M57x : /4AI
	GGIO2	GGIO_9	Generic Process I/O – 32 Virtual Output signals

Table 3 – M572 Breaker and ½

LD	LN Instance	LN Type	Description
Measurements			
	LLN0	LLN0_0	Measurements Logical Device
	LPHD	LPHD_0	Physical Device Information
	MMXU1	MMXU_10	M572 Bus 1 (V,A,W,VAr) Measurements (LN is extended to include custom measurements)
	MMXU2	MMXU_10	M572 Bus 2 (V,A,W,VAr) Measurements (LN is extended to include custom measurements)
	FndMMXU1	MMXU_7	Fundamental of Bus 1 (MMXU1) Measurements
	FndMMXU2	MMXU_7	Fundamental of Bus 2 (MMXU2) Measurements
	DmdMMXU1	MMXU_1	Present Thermal Demands of Bus 1 (MMXU1) Measurements
	DmdMMXU2	MMXU_1	Present Thermal Demands of Bus 2 (MMXU2) Measurements
	DmnMMXU1	MMXU_3	Minimum Thermal Demands of Bus 1 (MMXU1)
	DmnMMXU2	MMXU_3	Minimum Thermal Demands of Bus 2 (MMXU2)
	DmxMMXU1	MMXU_1	Maximum Thermal Demands of Bus 1 (MMXU1)
	DmxMMXU2	MMXU_1	Maximum Thermal Demands of Bus 2 (MMXU2)
	FndDmdMMXU1	MMXU_5	Fundamental Thermal Demands of Bus 1 (MMXU1)
	FndDmdMMXU2	MMXU_5	Fundamental Thermal Demands of Bus 2 (MMXU2)
	FndDmxMMXU1	MMXU_5	Fundamental Maximum Thermal Demands of Bus 1 (MMXU1)
	FndDmxMMXU2	MMXU_5	Fundamental Maximum Thermal Demands of Bus 2 (MMXU2)
	MMTR1	MMTR_0	Bus 1 Energy Metering Measurement (LN is extended to include custom measurements)
	MMTR2	MMTR_0	Bus 2 Energy Metering Measurement (LN is extended to include custom measurements)
	MSQI1	MSQI_0	Bus 1 Sequence Components (Volts & Amps)
	MSQI2	MSQI_0	Bus 2 Sequence Components (Volts & Amps)
	MHAI1	MHAI_2	Bus 1 Harmonics (Volts & Amps) including individual harmonics, phase related K factor and harmonic demand (LN is extended to include custom measurements)
	MHAI2	MHAI_2	Bus 2 Harmonics (Volts & Amps) including individual harmonics, phase related K factor and harmonic demand (LN is extended to include custom measurements)
	DmdMHAI1	MHAI_0	Present Thermal Demands for Bus 1 (MHAI1)
	DmdMHAI2	MHAI_0	Present Thermal Demands for Bus 2 (MHAI3)
	DmnMHAI1	MHAI_1	Minimum Thermal Demands for Bus 1 (MHAI1) - No minimum Amp demands
	DmnMHAI2	MHAI_1	Minimum Thermal Demands for Bus 2 (MHAI2) - No minimum Amp demands
	DmxMHAI1	MHAI_0	Maximum Thermal Demands for Bus 1 (MHAI1)
	DmxMHAI2	MHAI_0	Maximum Thermal Demands for Bus 2 (MHAI2)
	MLFK1	MLFK_0	Voltage Flicker Bus 1 Measurement (Custom LN)
	MLFK2	MLFK_0	Voltage Flicker Bus 2 Measurement (Custom LN)

LD	LN Instance	LN Type	Description
Measurements			
	MSYN1	MSYN_0	Synch check Bus1 to Bus 2 Phase A for M572 Breaker & ½ (Custom LN)
	MSYN2	MSYN_0	Synch check Bus1 to Bus 2 Phase B for M572 Breaker & ½ (Custom LN)
	MSYN3	MSYN_0	Synch check Bus1 to Bus 2 Phase C for M572 Breaker & ½ (Custom LN)
	MADV1	MADV_0	Advanced Measurements Bus 1 (Custom LN)
	MADV2	MADV_0	Advanced Measurements Bus 2 (Custom LN)
	MFLO1	MFLO_0	Fault Distance Measurement Bus 1 (Custom LN)
	MFLO2	MFLO_0	Fault Distance Measurement Bus 2 (Custom LN)
	MTMP1	MTMP_0	Temperature Measurement – Internal ambient (Custom LN)
Records			
	LLN0	LLN0_0	Records Logical Device
	LPHD	LDHD_0	Physical Device Information
	WrxRDRE1	RDRE_0	Waveform Recorder 1
	WrxRDRE2	RDRE_0	Waveform Recorder 2
	DrxRDRE1	RDRE_0	Disturbance Recorder 1
	DrxRDRE2	RDRE_0	Disturbance Recorder 2
System			
	LLN0	LLN0_1	System Logical Device Can only Publish GOOSE in System/LLN0
	LPHD	LPHD_0	Physical Device Information
	GosGGIO1	GGIO_8	GOOSE Input Status (GOOSE Subscriptions are done here)
	TVTR1	TVTR_0	Voltage Transformer Phase A Bus 1
	TVTR2	TVTR_0	Voltage Transformer Phase B Bus 1
	TVTR3	TVTR_0	Voltage Transformer Phase C Bus 1
	TVTR4	TVTR_0	Voltage Transformer Phase N Bus 1
	TVTR5	TVTR_0	Voltage Transformer Phase A Bus 2
	TVTR6	TVTR_0	Voltage Transformer Phase B Bus 2
	TVTR7	TVTR_0	Voltage Transformer Phase C Bus 2
	TVTR8	TVTR_0	Voltage Transformer Phase N Bus 2
	TCTR1	TCTR_0	Current Transformer Phase A Bus 1
	TCTR2	TCTR_0	Current Transformer Phase B Bus 1
	TCTR3	TCTR_0	Current Transformer Phase C Bus 1
	TCTR5	TCTR_0	Current Transformer Phase A Bus 2
	TCTR6	TCTR_0	Current Transformer Phase B Bus 2
	TCTR7	TCTR_0	Current Transformer Phase C Bus 2

System I/O Options (GGIO Logical slot number is fixed at 1).			
Choose option based on logical slot configuration	No GGIO option	No GGIO option	No generic Process I/O
Choose option based on logical slot configuration	GGIO1	GGIO_0	Generic Process I/O GGIO for M57x : 4DI/4DO
Choose option based on logical slot configuration	GGIO1	GGIO_3	Generic Process I/O GGIO for M57x : 4DI/4DO/4AI
Choose option based on logical slot configuration	GGIO1	GGIO_6	Generic Process I/O GGIO for M57x : /4AI
	GGIO2	GGIO_9	Generic Process I/O – 32 Virtual Output signals

Table 4 – M871

LD	LN Instance	LN Type	Description
Measurements			
	LLN0	LNN0_0	Measurements Logical Device
	LPHD	LPHD_0	Physical Device Information
	MMXU1	MMXU_9	M871 Bus 1 (V,A, W, VAr) Measurements (LN is extended to include custom measurements)
	MMXU2	MMXU_11	M871 Bus 2 (V) Measurements (LN is extended to include custom measurements)
	MMXN1	MMXN_0	M871 Auxiliary voltage 1 (V)
	MMXN2	MMXN_0	M871 Auxiliary voltage 2 (V)
	MMXN3	MMXN_0	M871 Auxiliary differential voltage (V)
	FndMMXU1	MMXU_6	Fundamental Measurements of Bus 1 (MMXU1)
	FndMMXU2	MMXU_8	Fundamental Measurements of Bus 2 (MMXU2)
	DmdMMXU1	MMXU_0	Present Thermal Demands of Bus 1 (MMXU1) Measurements
	DmdMMXU2	MMXU_2	Present Thermal Demands of Bus 2 (MMXU2) Measurements
	DmnMMXU1	MMXU_3	Minimum Thermal Demands of Bus 1 (MMXU1)
	DmnMMXU2	MMXU_2	Minimum Thermal Demands of Bus 2 (MMXU2)
	DmxMMXU1	MMXU_0	Maximum Thermal Demands of Bus 1 (MMXU1)
	DmxMMXU2	MMXU_2	Maximum Thermal Demands of Bus 2 (MMXU2)
	FndDmdMMXU1	MMXU_4	Fundamental Thermal Demands of Bus 1 (MMXU1)
	FndDmxMMXU1	MMXU_4	Fundamental Maximum Thermal Demands of Bus 1 (MMXU1)
	MMTR1	MMTR_0	Bus 1 Energy Metering Measurement (LN is extended to include custom measurements)
	MSQI1	MSQI_0	Bus 1 Sequence Components (Volts & Amps)
	MSQI2	MSQI_1	Bus 2 Sequence Components (Volts only)
	MHAI1	MHAI_2	Bus 1 Harmonics (Volts & Amps) including individual harmonics, phase related K factor and harmonic demand (LN is extended to include custom measurements)
	MHAI2	MHAI_3	Bus 2 Harmonics (Volts only) including individual harmonics and harmonic demand (LN is extended to include custom measurements)
	DmdMHAI1	MHAI_0	Present Thermal Demands for Bus 1 (MHAI1)
	DmdMHAI2	MHAI_1	Present Thermal Demands for Bus 2 (MHAI2) – Volts only
	DmnMHAI1	MHAI_1	Minimum Thermal Demands for Bus 1 (MHAI1) – No minimum Amp demands
	DmnMHAI2	MHAI_1	Minimum Thermal Demands for Bus 2 (MHAI2) - Volts only
	DmxMHAI1	MHAI_0	Maximum Thermal Demands for Bus 1 (MHAI1)
	DmxMHAI2	MHAI_1	Maximum Thermal Demands for Bus 2 (MHAI2) – Volts only
	MLFK1	MLFK_0	Voltage Flicker Bus 1 Measurement (Custom LN)
	MLFK2	MLFK_0	Voltage Flicker Bus 2 Measurement (Custom LN)
	MSYN1	MSYN_0	Synch check Bus1 to Bus 2 Phase A (Custom LN)

LD	LN Instance	LN Type	Description
Measurements			
	MSYN2	MSYN_0	Synch check Bus1 to Bus 2 Phase B (Custom LN)
	MSYN3	MSYN_0	Synch check Bus1 to Bus 2 Phase C (Custom LN)
	MADV1	MADV_0	Advanced Measurements Bus 1 (Custom LN)
	MFLO1	MFLO_0	Fault Distance Measurement Bus 1 (Custom LN)
	MTMP1	MTMP_0	Temperature Measurement –Internal ambient (Custom LN)
Records			
	LLN0	LLN0_0	Records Logical Device
	LPHD	LDHD_0	Physical Device Information
	WrxRDRE1	RDRE_0	Waveform Recorder 1
	WrxRDRE2	RDRE_0	Waveform Recorder 2
	DrxRDRE1	RDRE_0	Disturbance Recorder 1
	DrxRDRE2	RDRE_0	Disturbance Recorder 2
System			
	LLN0	LLN0_1	System Logical Device Can only Publish GOOSE in System/LLN0
	LPHD	LPHD_0	Physical Device Information
	GosGGIO1	GGIO_8	GOOSE Input Status (GOOSE Subscriptions are done here)
	TVTR1	TVTR_0	Voltage Transformer Phase A Bus 1
	TVTR2	TVTR_0	Voltage Transformer Phase B Bus 1
	TVTR3	TVTR_0	Voltage Transformer Phase C Bus 1
	TVTR4	TVTR_0	Voltage Transformer Phase N Bus 1
	TVTR5	TVTR_0	Voltage Transformer Phase A Bus 2
	TVTR6	TVTR_0	Voltage Transformer Phase B Bus 2
	TVTR7	TVTR_0	Voltage Transformer Phase C Bus 2
	TVTR8	TVTR_0	Voltage Transformer Phase N Bus 2
	TVTR9	TVTR_0	Voltage Transformer - Auxiliary voltage 1
	TVTR10	TVTR_0	Voltage Transformer - Auxiliary voltage 2
	TVTR11	TVTR_0	Voltage Transformer - differential auxiliary voltage
	TCTR1	TCTR_0	Current Transformer Phase A Bus 1
	TCTR2	TCTR_0	Current Transformer Phase B Bus 1
	TCTR3	TCTR_0	Current Transformer Phase C Bus 1
	TCTR4	TCTR_0	Current Transformer Phase N Bus 1

System I/O Options (GGIO Logical slot numbers may range from 1 -7).			
Chose option based on logical slot configuration	No GGIO option	No GGIO option	No generic Process I/O
Chose option based on logical slot configuration	GGIOx (see Note 1)	GGIO_1	Generic Process I/O (P30) GGIO for logical slot x-1: 8DI/4DO
Chose option based on logical slot configuration	GGIOx (see Note 1)	GGIO_2	Generic Process I/O (P31) GGIO for logical slot x-1: 16DI/4DO
Chose option based on logical slot configuration	GGIOx (see Note 1)	GGIO_4	Generic Process I/O (P30+P40) GGIO for logical slot x-1 (P30) & logical slot x (P40): 8DI/4DO/8AI
Chose option based on logical configuration	GGIOx (see Note 1)	GGIO_5	Generic Process I/O (P31+P40) GGIO for logical slot x-1 (P31) & logical slot x (P40): 16DI/4DO/8AI
	GGIO2	GGIO_9	Generic Process I/O – 32 Virtual Output signals

Table 5 –M872 Dual Feeder

LD	LN Instance	LN Type	Description
Measurements			
	LLN0	LLN0_0	Measurements Logical Device
	LPHD	LPHD_0	Physical Device Information
	MMXU1	MMXU_10	M872 Bus 1 (V,A,W,VAr) Measurements (LN is extended to include custom measurements)
	MMXU2	MMXU_10	M872 Bus 2 (V,A,W,VAr) Measurements (LN is extended to include custom measurements)
	MMXN1	MMXN_0	M872 Dual Feeder Voltage Reference 1 (V)
	MMXN2	MMXN_0	M872 Dual Feeder Voltage Reference 2 (V)
	FndMMXU1	MMXU_7	Fundamental Measurements of Bus 1 (MMXU1)
	FndMMXU2	MMXU_7	Fundamental Measurements of Bus 2 (MMXU2)
	DmdMMXU1	MMXU_1	Present Thermal Demands of Bus 1 (MMXU1) Measurements
	DmdMMXU2	MMXU_1	Present Thermal Demands of Bus 2 (MMXU2) Measurements
	DmnMMXU1	MMXU_3	Minimum Thermal Demands of Bus 1 (MMXU1)
	DmnMMXU2	MMXU_3	Minimum Thermal Demands of Bus 2 (MMXU2)
	DmxMMXU1	MMXU_1	Maximum Thermal Demands of Bus 1 (MMXU1)
	DmxMMXU2	MMXU_1	Maximum Thermal Demands of Bus 2 (MMXU2)
	FndDmdMMXU1	MMXU_5	Fundamental Thermal Demands of Bus 1 (MMXU1)
	FndDmdMMXU2	MMXU_5	Fundamental Thermal Demands of Bus 2 (MMXU2)
	FndDmxMMXU1	MMXU_5	Fundamental Maximum Thermal Demands of Bus 1 (MMXU1)
	FndDmxMMXU2	MMXU_5	Fundamental Maximum Thermal Demands of Bus 2 (MMXU2)
	MMTR1	MMTR_0	Bus 1 Energy Metering Measurement (LN is extended to include custom measurements)
	MMTR2	MMTR_0	Bus 2 Energy Metering Measurement (LN is extended to include custom measurements)
	MSQI1	MSQI_0	Bus 1 Sequence Components (Volts & Amps)
	MSQI2	MSQI_0	Bus 2 Sequence Components (Volts & Amps)
	MHAI1	MHAI_2	Bus 1 Harmonics (Volts & Amps) including individual harmonics, phase related K factor and harmonic demand (LN is extended to include custom measurements)
	MHAI2	MHAI_2	Bus 2 Harmonics (Volts & Amps) including individual harmonics, phase related K factor and harmonic demand (LN is extended to include custom measurements)
	DmdMHAI1	MHAI_0	Present Thermal Demands for Bus 1 (MHAI1)
	DmdMHAI2	MHAI_0	Present Thermal Demands for Bus 2 (MHAI2)
	DmnMHAI1	MHAI_1	Minimum Thermal Demands for Bus 1 (MHAI1) – No minimum Amp demands
	DmnMHAI2	MHAI_1	Minimum Thermal Demands for Bus 2 (MHAI2) - No minimum Amp demands
	DmxMHAI1	MHAI_0	Maximum Thermal Demands for Bus 1 (MHAI1)
	DmxMHAI2	MHAI_0	Maximum Thermal Demands for Bus 2 (MHAI2)
	MLFK1	MLFK_0	Voltage Flicker Bus 1 Measurement (Custom LN)
	MLFK2	MLFK_0	Voltage Flicker Bus 2 Measurement (Custom LN)
	MSYN1	MSYN_0	Synch check Bus 1, Phase A to VREF1 (Custom LN)

LD	LN Instance	LN Type	Description
Measurements			
	MSYN2	MSYN_0	Synch check Bus 1 Phase B to VREF1 (Custom LN)
	MSYN3	MSYN_0	Synch check Bus 1 Phase C to VREF1 (Custom LN)
	MSYN4	MSYN_0	Synch check Bus 1 Phase A to VREF2 (Custom LN)
	MSYN5	MSYN_0	Synch check Bus 1 Phase B to VREF2 (Custom LN)
	MSYN6	MSYN_0	Synch check Bus 1 Phase C to VREF2 (Custom LN)
	MADV1	MADV_0	Advanced Measurements Bus 1 (Custom LN)
	MADV2	MADV_0	Advanced Measurements Bus 2 (Custom LN)
	MFLO1	MFLO_0	Fault Distance Measurement Bus 1 (Custom LN)
	MFLO2	MFLO_0	Fault Distance Measurement Bus 2 (Custom LN)
	MTMP1	MTMP_0	Temperature Measurement- internal ambient (Custom LN)
Records			
	LLN0	LLN0_0	Records Logical Device
	LPHD	LDHD_0	Physical Device Information
	WrxRDRE1	RDRE_0	Waveform Recorder 1
	WrxRDRE2	RDRE_0	Waveform Recorder 2
	DrxRDRE1	RDRE_0	Disturbance Recorder 1
	DrxRDRE2	RDRE_0	Disturbance Recorder 2
System			
	LLN0	LLN0_1	System Logical Device Can only Publish GOOSE in System/LLN0
	LPHD	LPHD_0	Physical Device Information
	GosGGIO1	GGIO_8	GOOSE Input Status (GOOSE Subscriptions are done here)
	TVTR1	TVTR_0	Voltage Transformer Phase A Bus 1
	TVTR2	TVTR_0	Voltage Transformer Phase B Bus 1
	TVTR3	TVTR_0	Voltage Transformer Phase C Bus 1
	TVTR4	TVTR_0	Voltage Transformer Phase N Bus 1
	TVTR5	TVTR_0	Voltage Transformer Phase A Bus 2
	TVTR6	TVTR_0	Voltage Transformer Phase B Bus 2
	TVTR7	TVTR_0	Voltage Transformer Phase C Bus 2
	TVTR8	TVTR_0	Voltage Transformer Phase N Bus 2
	TVTR9	TVTR_0	Voltage Transformer for Vref1
	TVTR10	TVTR_0	Voltage Transformer for Vref2
	TCTR1	TCTR_0	Current Transformer Phase A Bus 1
	TCTR2	TCTR_0	Current Transformer Phase B Bus 1
	TCTR3	TCTR_0	Current Transformer Phase C Bus 1
	TCTR5	TCTR_0	Current Transformer Phase A Bus 2
	TCTR6	TCTR_0	Current Transformer Phase B Bus 2
	TCTR7	TCTR_0	Current Transformer Phase C Bus 2

System I/O Options (GGIO Logical slot numbers may range from 1-7).			
Choose option based on logical slot configuration	No GGIO option	No GGIO option	No generic Process I/O
Choose option based on logical slot configuration	GGIOx (see Note 1)	GGIO_1	Generic Process I/O (P30) GGIO for logical slot x-1: 8DI/4DO
Choose option based on logical slot configuration	GGIOx (see Note 1)	GGIO_2	Generic Process I/O (P31) GGIO for logical slot x-1: 16DI/4DO
Choose option based on logical slot configuration	GGIOx (see Note 1)	GGIO_4	Generic Process I/O (P30+P40) GGIO for logical slot x-1 (P30) & logical slot x (P40): 8DI/4DO/8AI
Choose option based on logical slot configuration	GGIOx (see Note 1)	GGIO_5	Generic Process I/O (P31+P40) GGIO for logical slot x-1 (P31) & logical slot x (P40): 16DI/4DO/8AI
Choose option based on logical slot configuration	GGIOx (see Note 1)	GGIO_7	Generic Process I/O (P40) GGIO for logical slot x: /8AI
	GGIO2	GGIO_9	Generic Process I/O – 32 Virtual Output signals

Table 6 –M872 Breaker and ½

LD	LN Instance	LN Type	Description
Measurements			
	LLN0	LLN0_0	Measurements Logical Device
	LPHD	LPHD_0	Physical Device Information
	MMXU1	MMXU_10	M872 Bus 1 (V,A,W,VAr) Measurements (LN is extended to include custom measurements)
	MMXU2	MMXU_10	M872 Bus 2 (V,A,W,VAr) Measurements (LN is extended to include custom measurements)
	FndMMXU1	MMXU_7	Fundamental of Bus 1 (MMXU1) Measurements
	FndMMXU2	MMXU_7	Fundamental of Bus 2 (MMXU2) Measurements
	DmdMMXU1	MMXU_1	Present Thermal Demands of Bus 1 (MMXU1) Measurements
	DmdMMXU2	MMXU_1	Present Thermal Demands of Bus 2 (MMXU2) Measurements
	DmnMMXU1	MMXU_3	Minimum Thermal Demands of Bus 1 (MMXU1)
	DmnMMXU2	MMXU_3	Minimum Thermal Demands of Bus 2 (MMXU2)
	DmxMMXU1	MMXU_1	Maximum Thermal Demands of Bus 1 (MMXU1)
	DmxMMXU2	MMXU_1	Maximum Thermal Demands of Bus 2 (MMXU2)
	FndDmdMMXU1	MMXU_5	Fundamental Thermal Demands of Bus 1 (MMXU1)
	FndDmdMMXU2	MMXU_5	Fundamental Thermal Demands of Bus 2 (MMXU2)
	FndDmxMMXU1	MMXU_5	Fundamental Maximum Thermal Demands of Bus 1 (MMXU1)
	FndDmxMMXU2	MMXU_5	Fundamental Maximum Thermal Demands of Bus 2 (MMXU2)
	MMTR1	MMTR_0	Bus 1 Energy Metering Measurement (LN is extended to include custom measurements)
	MMTR2	MMTR_0	Bus 2 Energy Metering Measurement (LN is extended to include custom measurements)
	MSQI1	MSQI_0	Bus 1 Sequence Components (Volts & Amps)
	MSQI2	MSQI_0	Bus 2 Sequence Components (Volts & Amps)
	MHAI1	MHAI_2	Bus 1 Harmonics (Volts & Amps) including individual harmonics, phase related K factor and harmonic demand (LN is extended to include custom measurements)
	MHAI2	MHAI_2	Bus 2 Harmonics (Volts & Amps) including individual harmonics, phase related K factor and harmonic demand (LN is extended to include custom measurements)
	DmdMHAI1	MHAI_0	Present Thermal Demands for Bus 1 (MHAI1)
	DmdMHAI2	MHAI_0	Present Thermal Demands for Bus 2 (MHAI2)
	DmnMHAI1	MHAI_1	Minimum Thermal Demands for Bus 1 (MHAI1) - No minimum Amp demands
	DmnMHAI2	MHAI_1	Minimum Thermal Demands for Bus 2 (MHAI2) - No minimum Amp demands
	DmxMHAI1	MHAI_0	Maximum Thermal Demands for Bus 1 (MHAI1)
	DmxMHAI2	MHAI_0	Maximum Thermal Demands for Bus 2 (MHAI2)
	MLFK1	MLFK_0	Voltage Flicker Bus 1 Measurement (Custom LN)

LD	LN Instance	LN Type	Description
Measurements			
	MLFK2	MLFK_0	Voltage Flicker Bus 2 Measurement (Custom LN)
	MSYN1	MSYN_0	Synch check Bus1 to Bus 2 Phase A for M872 (Breaker & 1/2) (Custom LN)
	MSYN2	MSYN_0	Synch check Bus1 to Bus 2 Phase B for M872 (Breaker & 1/2) (Custom LN)
	MSYN3	MSYN_0	Synch check Bus1 to Bus 2 Phase C for M872 (Breaker & 1/2) (Custom LN)
	MADV1	MADV_0	Advanced Measurements Bus 1 (Custom LN)
	MADV2	MADV_0	Advanced Measurements Bus 2 (Custom LN)
	MFLO1	MFLO_0	Fault Distance Measurement Bus 1 (Custom LN)
	MFLO2	MFLO_0	Fault Distance Measurement Bus 2 (Custom LN)
	MTMP1	MTMP_0	Temperature Measurement – internal ambient (Custom LN)
Records			
	LLN0	LLN0_0	Records Logical Device
	LPHD	LDHD_0	Physical Device Information
	WrxRDRE1	RDRE_0	Waveform Recorder 1
	WrxRDRE2	RDRE_0	Waveform Recorder 2
	DrxRDRE1	RDRE_0	Disturbance Recorder 1
	DrxRDRE2	RDRE_0	Disturbance Recorder 2
System			
	LLN0	LLN0_1	System Logical Device Can only Publish GOOSE in System/LLN0
	LPHD	LPHD_0	Physical Device Information
	GosGGIO1	GGIO_8	GOOSE Input Status (GOOSE Subscriptions are done here)
	TVTR1	TVTR_0	Voltage Transformer Phase A Bus 1
	TVTR2	TVTR_0	Voltage Transformer Phase B Bus 1
	TVTR3	TVTR_0	Voltage Transformer Phase C Bus 1
	TVTR4	TVTR_0	Voltage Transformer Phase N Bus 1
	TVTR5	TVTR_0	Voltage Transformer Phase A Bus 2
	TVTR6	TVTR_0	Voltage Transformer Phase B Bus 2
	TVTR7	TVTR_0	Voltage Transformer Phase C Bus 2
	TVTR8	TVTR_0	Voltage Transformer Phase N Bus 2
	TCTR1	TCTR_0	Current Transformer Phase A Bus 1
	TCTR2	TCTR_0	Current Transformer Phase B Bus 1
	TCTR3	TCTR_0	Current Transformer Phase C Bus 1
	TCTR5	TCTR_0	Current Transformer Phase A Bus 2
	TCTR6	TCTR_0	Current Transformer Phase B Bus 2
	TCTR7	TCTR_0	Current Transformer Phase C Bus 2

System I/O Options (GGIO Logical slot numbers may range from 1 -7).			
Choose option based on logical slot configuration	No GGIO option	No GGIO option	No generic Process I/O
Choose option based on logical slot configuration	GGIOx (see Note 1)	GGIO_1	Generic Process I/O (P30) GGIO for logical slot x-1: 8DI/4DO
Choose option based on logical slot configuration	GGIOx (see Note 1)	GGIO_2	Generic Process I/O (P31) GGIO for logical slot x-1: 16DI/4DO
Choose option based on logical slot configuration	GGIOx (see Note 1)	GGIO_4	Generic Process I/O (P30+P40) GGIO for logical slot x-1 (P30) & logical slot x (P40): 8DI/4DO/8AI
Choose option based on logical slot configuration	GGIOx (see Note 1)	GGIO_5	Generic Process I/O (P31+P40) GGIO for logical slot x-1 (P31) & logical slot x (P40): 16DI/4DO/8AI
Choose option based on logical slot configuration	GGIOx (see Note 1)	GGIO_7	Generic Process I/O (P40) GGIO for logical slot x: /8AI
	GGIO2	GGIO_9	Generic Process I/O – 32 Virtual Output signals

3.4 Logical Node definitions

The definition tables for each of the Logical Nodes in the top-level data model are presented in the following sub-sections.

The following table presents a summary of the Logical Node templates used across the Logical Devices within the overall IEC61850 product data model:

Table 7: LN Type Definitions

LN Type	(LN Class)	Description	Name Space
GGIO_0	(GGIO)	Generic Process I/O – M57x with option of 4 Digital Inputs / 4 Digital Outputs	IEC61850-7-4:2003
GGIO_1	(GGIO)	Generic Process I/O – M87x with option of 8 Digital Inputs/4 Digital Outputs	IEC61850-7-4:2003
GGIO_2	(GGIO)	Generic Process I/O – M87x with option of 16 Digital inputs/4 Digital outputs	IEC61850-7-4:2003
GGIO_3	(GGIO)	Generic Process I/O – M57x with option of 4 Digital Inputs/ 4 Digital Outputs/ 4 Analog Inputs	IEC61850-7-4:2003
GGIO_4	(GGIO)	Generic Process I/O – M87x with options of 8 Digital inputs / 4 Digital outputs / 8 Analog inputs	IEC61850-7-4:2003
GGIO_5	(GGIO)	Generic Process I/O – M87x with options of 16 Digital inputs / 4 Digital outputs / 8 Analog inputs	IEC61850-7-4:2003
GGIO_6	(GGIO)	Generic Process I/O - M57x with option of 4 Analog Inputs	IEC61850-7-4:2003
GGIO_7	(GGIO)	Generic Process I/O - M87x with option of 8 Analog Inputs	IEC61850-7-4:2003
GGIO_8	(GGIO)	Generic Process I/O - GOOSE Message	IEC61850-7-4:2003
GGIO_9	(GGIO)	Generic Process I/O – Virtual Output signals	IEC61850-7-4:2003

LN Type	(LN Class)	Description	Name Space
LLN0_0	(LLN0)	Common information for the logical device which applies to logical nodes in the Measurements and Records Domains	IEC61850-7-4:2003
LLN0_1	(LLN0)	Common information for logical device, which applies to logical nodes in the Systems Domain	IEC61850-7-4:2003
LPHD_0	(LPHD)	Mx70 Physical Device Information	IEC61850-7-4:2003
MADV_0	(MADV)	Advanced Measurements (Custom LN definition is found in this section of the manual)	Bitronics NS Not Standard
MFLK_0	(MFLK)	Flicker measurements (Custom LN definition is found in this section of the manual)	Bitronics NS Not Standard
MFLO_0	(MFLO)	Fault Distance Measurement calculated for a Fault Location (Custom LN definition is found in this section of the manual)	Bitronics NS Not Standard
MHAI_0	(MHAI)	Harmonic information for Volts and Amps without the individual harmonics	IEC61850-7-4:2003
MHAI_1	(MHAI)	Harmonic information for Volts only (No Amps) without the individual harmonics	IEC61850-7-4:2003
MHAI_2	(MHAI)	Harmonic information for Volts and Amps, etc. including the individual harmonics, phase related K factor and harmonic demand. (Provides measurements of individual harmonic magnitudes and angles for polyphase analogue values.) (LN is extended to include custom measurements)	IEC61850-7-4:2003
MHAI_3	(MHAI)	Harmonic information for Volts only (No Amps), etc. including the individual harmonics and harmonic demand. (Provides measurements of individual harmonic magnitudes and angles for polyphase analogue values for voltage only.) (LN is extended to include custom measurements)	IEC61850-7-4:2003
MMTR_0	(MMTR)	Energy measurements (Provides for acquiring of polyphase metering values pertaining to a field device or circuit.) (LN is extended to include custom measurements)	IEC61850-7-4:2003
MMXN_0	(MMXN)	Auxiliary voltage Measurements for M871 or Dual Feeder Reference voltage measurements for Mx72	IEC61850-7-4:2003
MMXU_0	(MMXU)	Standard Measurements: Present and Maximum Thermal Demands - Bus 1 (M871) (Provides measurements of single phase or polyphase analog values, including neutral, pertaining to a wye or delta connected field device or circuit.)	IEC61850-7-4:2003
MMXU_1	(MMXU)	Standard Measurements: Present and Maximum Thermal Demands - Bus 1 (M571, M572, M872) - Bus 2 (M572, M872)	IEC61850-7-4:2003

LN Type	(LN Class)	Description	Name Space
		(Provides measurements of single phase or polyphase analog values pertaining to a wye or delta connected field device or circuit.)	
MMXU_2	(MMXU)	Standard Measurements: Present, Minimum and Maximum Thermal Demands (Volts only) - Bus 2 (M571, M871) (Provides measurements of single phase or polyphase analog values pertaining to a wye or delta connected field device or circuit.)	IEC61850-7-4:2003
MMXU_3	(MMXU)	Standard Measurements: Minimum Thermal Demands - Bus 1 (M571, M572, M871, M872) - Bus2 (M572, M872) (Provides measurements of single phase or polyphase analog values pertaining to a wye or delta connected field device or circuit.)	IEC61850-7-4:2003
MMXU_4	(MMXU)	Standard Measurements: Fundamental Thermal Demands and Fundamental Maximum Thermal Demands - Bus 1 (M871) (Provides measurements of single phase or polyphase analog values pertaining to a wye or delta connected field device or circuit.)	IEC61850-7-4:2003
MMXU_5	(MMXU)	Standard Measurements: Fundamental Thermal Demands and Fundamental Maximum Thermal Demands - Bus 1 (M571, M572, M872) - Bus 2 (M572, M872) (Provides measurements of single phase or polyphase analog values pertaining to a wye or delta connected field device or circuit.)	IEC61850-7-4:2003
MMXU_6	(MMXU)	Standard Measurements: Fundamental (Fourier) values – Bus 1 (M871) (Provides measurements of single phase or polyphase analog values pertaining to a wye or delta connected field device or circuit.)	IEC61850-7-4:2003
MMXU_7	(MMXU)	Standard Measurements: Fundamental (Fourier) values - Bus 1 (M571, M572, M872) - Bus 2 (M572, M872) (Provides measurements of single phase or polyphase analog values pertaining to a wye or delta connected field device or circuit.)	IEC61850-7-4:2003
MMXU_8	(MMXU)	Standard Measurements: Fundamental (Fourier) values (Volts and frequency only) - Bus 2 (M571, M871) (Provides measurements of single phase or polyphase analog values pertaining to a wye or delta connected field device or circuit.)	IEC61850-7-4:2003

LN Type	(LN Class)	Description	Name Space
MMXU_9	(MMXU)	Standard measurements - Bus 1 (M871) (Provides measurements of single phase or polyphase analog values pertaining to a wye or delta connected field device or circuit.) (LN is extended to include custom measurements)	IEC61850-7-4:2003
MMXU_10	(MMXU)	Standard measurements - Bus 1 (M571, M572, M872) - Bus 2 (M572, M872) (Provides measurements of single phase or polyphase analog values pertaining to a wye or delta connected field device or circuit.) (LN is extended to include custom measurements)	IEC61850-7-4:2003
MMXU_11	(MMXU)	Standard measurements - Bus 2 (M571, M871) (Provides measurements of single phase or polyphase analog values pertaining to a wye or delta connected field device or circuit.) (LN is extended to include custom measurements)	IEC61850-7-4:2003
MSQI_0	(MSQI)	Sequence and imbalance - Volts and Amps (Pos, Neq, Zero) for three phase power systems (Provides for Measurement of polyphase analog values representing sequence components)	IEC61850-7-4:2003
MSQI_1	(MSQI)	Sequence and imbalance - Volts only (Pos, Neq, Zero) for three phase power systems (No Amps) (Provides for Measurement of polyphase analog values representing sequence components)	IEC61850-7-4:2003
MSYN_0	(MSYN)	Synchronism check (Calculated differential measurements for rms voltage, frequency, and phase) (Custom LN definition is found in this section of the manual)	Bitronics NS Not Standard
MTMP_0	(MTMP)	Internal Ambient Temperature for the logical device (Custom LN definition is found in this section of the manual)	Bitronics NS Not Standard
RDRE_0	(RDRE)	Disturbance Recorder function	IEC61850-7-4:2003
TCTR_0	TCTR	Current Transformer (CT) – per Bus and phase	IEC61850-7-4:2003
TVTR_0	TVTR	Voltage Transformer (VT) - per Bus and phase , Auxiliary Voltage Measurements (M871) or Reference Voltage Measurements for Dual Feeder (572, M872)	IEC61850-7-4:2003

3.4.1 Logical Node: GGIO_0

Description: Generic Process I/O – M57x with option of 4 Digital Inputs / 4 Digital Outputs

LN Class: GGIO

Attribute	Attr. Type	Explanation	T	X
Mod	INC_0	Mode		
Beh	INS_0	Behaviour		
Health	INS_1	Health		
NamPlt	LPL_0	Name Plate		
SPCSO1	SPC_3	Digital Output 1		
SPCSO2	SPC_3	Digital Output 2		
SPCSO3	SPC_3	Digital Output 3		
SPCSO4	SPC_3	Digital Output 4		
Ind1	SPS_0	Digital Input 1		
Ind2	SPS_0	Digital Input 2		
Ind3	SPS_0	Digital Input 3		
Ind4	SPS_0	Digital Input 4		

3.4.2 Logical Node: GGIO_1

Description: Generic Process I/O – M87x with option of 8 Digital Inputs/4 Digital Outputs

LN Class: GGIO

Attribute	Attr. Type	Explanation	T	X
Mod	INC_0	Mode		
Beh	INS_0	Behaviour		
Health	INS_1	Health		
NamPlt	LPL_0	Name Plate		
SPCSO1	SPC_3	Digital Output 1		
SPCSO2	SPC_3	Digital Output 2		
SPCSO3	SPC_3	Digital Output 3		
SPCSO4	SPC_3	Digital Output 4		
Ind1	SPS_0	Digital Input 1		
Ind2	SPS_0	Digital Input 2		
Ind3	SPS_0	Digital Input 3		
Ind4	SPS_0	Digital Input 4		
Ind5	SPS_0	Digital Input 5		
Ind6	SPS_0	Digital Input 6		
Ind7	SPS_0	Digital Input 7		
Ind8	SPS_0	Digital Input 8		

3.4.3 Logical Node: GGIO_2

Description: Generic Process I/O – M87x with option of 16 Digital inputs/4 Digital outputs

LN Class: GGIO

Attribute	Attr. Type	Explanation	T	X
Mod	INC_0	Mode		
Beh	INS_0	Behaviour		
Health	INS_1	Health		
NamPlt	LPL_0	Name Plate		
SPCSO1	SPC_3	Digital Output 1		
SPCSO2	SPC_3	Digital Output 2		
SPCSO3	SPC_3	Digital Output 3		
SPCSO4	SPC_3	Digital Output 4		
Ind1	SPS_0	Digital Input 1		
Ind2	SPS_0	Digital Input 2		
Ind3	SPS_0	Digital Input 3		
Ind4	SPS_0	Digital Input 4		
Ind5	SPS_0	Digital Input 5		
Ind6	SPS_0	Digital Input 6		
Ind7	SPS_0	Digital Input 7		
Ind8	SPS_0	Digital Input 8		
Ind9	SPS_0	Digital Input 9		
Ind10	SPS_0	Digital Input 10		
Ind11	SPS_0	Digital Input 11		
Ind12	SPS_0	Digital Input 12		
Ind13	SPS_0	Digital Input 13		
Ind14	SPS_0	Digital Input 14		
Ind15	SPS_0	Digital Input 15		
Ind16	SPS_0	Digital Input 16		

3.4.4 Logical Node: GGIO_3

Description: Generic Process I/O – M57x with option of 4 Digital Inputs/ 4 Digital Outputs/ 4 Analog Inputs

LN Class: GGIO

Attribute	Attr. Type	Explanation	T	X
Mod	INC_0	Mode		
Beh	INS_0	Behaviour		
Health	INS_1	Health		
NamPlt	LPL_0	Name Plate		
AnIn1	MV_0	Analog input 1		
AnIn 2	MV_0	Analog input 2		
AnIn 3	MV_0	Analog input 3		
AnIn 4	MV_0	Analog input 4		
SPCSO1	SPC_3	Digital Output 1		
SPCSO2	SPC_3	Digital Output 2		
SPCSO3	SPC_3	Digital Output 3		
SPCSO4	SPC_3	Digital Output 4		
Ind1	SPS_0	Digital Input 1		
Ind2	SPS_0	Digital Input 2		
Ind3	SPS_0	Digital Input 3		
Ind4	SPS_0	Digital Input 4		

3.4.5 Logical Node: GGIO_4

Description: Generic Process I/O – M87x with options of 8 Digital inputs / 4 Digital outputs / 8 Analog inputs

LN Class: GGIO

Attribute	Attr. Type	Explanation	T	X
Mod	INC_0	Mode		
Beh	INS_0	Behaviour		
Health	INS_1	Health		
NamPlt	LPL_0	Name Plate		
AnIn1	MV_0	Analog input 1		
AnIn 2	MV_0	Analog input 2		
AnIn 3	MV_0	Analog input 3		
AnIn 4	MV_0	Analog input 4		
AnIn5	MV_0	Analog input 5		
AnIn 6	MV_0	Analog input 6		
AnIn 7	MV_0	Analog input 7		
AnIn 8	MV_0	Analog input 8		
SPCSO1	SPC_3	Digital Output 1		
SPCSO2	SPC_3	Digital Output 2		
SPCSO3	SPC_3	Digital Output 3		
SPCSO4	SPC_3	Digital Output 4		
Ind1	SPS_0	Digital Input 1		
Ind2	SPS_0	Digital Input 2		
Ind3	SPS_0	Digital Input 3		
Ind4	SPS_0	Digital Input 4		
Ind5	SPS_0	Digital Input 5		
Ind6	SPS_0	Digital Input 6		
Ind7	SPS_0	Digital Input 7		
Ind8	SPS_0	Digital Input 8		

3.4.6 Logical Node: GGIO_5

Description: Generic Process I/O – M87x with options of 16 Digital inputs / 4 Digital outputs / 8 Analog inputs

LN Class: GGIO

Attribute	Attr. Type	Explanation	T	X
Mod	INC_0	Mode		
Beh	INS_0	Behaviour		
Health	INS_1	Health		
NamPlt	LPL_0	Name Plate		
AnIn1	MV_0	Analog input 1		
AnIn 2	MV_0	Analog input 2		
AnIn 3	MV_0	Analog input 3		
AnIn 4	MV_0	Analog input 4		
AnIn5	MV_0	Analog input 5		
AnIn 6	MV_0	Analog input 6		
AnIn 7	MV_0	Analog input 7		
AnIn 8	MV_0	Analog input 8		
SPCSO1	SPC_3	Digital Output 1		
SPCSO2	SPC_3	Digital Output 2		
SPCSO3	SPC_3	Digital Output 3		
SPCSO4	SPC_3	Digital Output 4		
Ind1	SPS_0	Digital Input 1		
Ind2	SPS_0	Digital Input 2		
Ind3	SPS_0	Digital Input 3		
Ind4	SPS_0	Digital Input 4		
Ind5	SPS_0	Digital Input 5		
Ind6	SPS_0	Digital Input 6		
Ind7	SPS_0	Digital Input 7		
Ind8	SPS_0	Digital Input 8		
Ind9	SPS_0	Digital Input 9		
Ind10	SPS_0	Digital Input 10		
Ind11	SPS_0	Digital Input 11		
Ind12	SPS_0	Digital Input 12		
Ind13	SPS_0	Digital Input 13		
Ind14	SPS_0	Digital Input 14		
Ind15	SPS_0	Digital Input 15		
Ind16	SPS_0	Digital Input 16		

3.4.7 Logical Node: GGIO_6

Description: Generic Process I/O - M57x with option of 4 Analog Inputs

LN Class: GGIO

Attribute	Attr. Type	Explanation	T	X
Mod	INC_0	Mode		
Beh	INS_0	Behaviour		
Health	INS_1	Health		
NamPlt	LPL_0	Name Plate		
AnIn1	MV_0	Analog input 1		
AnIn 2	MV_0	Analog input 2		
AnIn 3	MV_0	Analog input 3		
AnIn 4	MV_0	Analog input 4		

3.4.8 Logical Node: GGIO_7

Description: Generic Process I/O - M87x with option of 8 Analog Inputs

LN Class: GGIO

Attribute	Attr. Type	Explanation	T	X
Mod	INC_0	Mode		
Beh	INS_0	Behaviour		
Health	INS_1	Health		
NamPlt	LPL_0	Name Plate		
AnIn1	MV_0	Analog input 1		
AnIn 2	MV_0	Analog input 2		
AnIn 3	MV_0	Analog input 3		
AnIn 4	MV_0	Analog input 4		
AnIn5	MV_0	Analog input 5		
AnIn 6	MV_0	Analog input 6		
AnIn 7	MV_0	Analog input 7		
AnIn 8	MV_0	Analog input 8		

3.4.9 Logical Node: GGIO_8

Description: Generic Process I/O - GOOSE Message

LN Class: GGIO

Attribute	Attr. Type	Explanation	T	X
Mod	INC_0	Mode		
Beh	INS_0	Behaviour		
Health	INS_1	Health		
NamPlt	LPL_0	Name Plate		
AnIn1	MV_1	GOOSE Floating point input 1		
AnIn 2	MV_1	GOOSE Floating point input2		
AnIn 3	MV_1	GOOSE Floating point input 3		
AnIn 4	MV_1	GOOSE Floating point input 4		
AnIn5	MV_1	GOOSE Floating point input 5		
AnIn 6	MV_1	GOOSE Floating point input 6		
AnIn 7	MV_1	GOOSE Floating point input 7		
AnIn 8	MV_1	GOOSE Floating point input 8		
AnIn 9	MV_1	GOOSE Floating point input 9		
AnIn 10	MV_1	GOOSE Floating point input 10		
AnIn 11	MV_1	GOOSE Floating point input 11		
AnIn 12	MV_1	GOOSE Floating point input 12		
AnIn 13	MV_1	GOOSE Floating point input 13		
AnIn 14	MV_1	GOOSE Floating point input 14		
AnIn 15	MV_1	GOOSE Floating point input 15		
AnIn 16	MV_1	GOOSE Floating point input 16		
AnIn 17	MV_1	GOOSE Floating point input 17		
AnIn 18	MV_1	GOOSE Floating point input 18		
AnIn 19	MV_1	GOOSE Floating point input 19		
AnIn 20	MV_1	GOOSE Floating point input 20		
AnIn 21	MV_1	GOOSE Floating point input 21		
AnIn 22	MV_1	GOOSE Floating point input 22		
AnIn 23	MV_1	GOOSE Floating point input 23		
AnIn 24	MV_1	GOOSE Floating point input 24		
AnIn 25	MV_1	GOOSE Floating point input 25		
AnIn 26	MV_1	GOOSE Floating point input 26		
AnIn 27	MV_1	GOOSE Floating point input 27		
AnIn 28	MV_1	GOOSE Floating point input 28		
AnIn 29	MV_1	GOOSE Floating point input 29		
AnIn 30	MV_1	GOOSE Floating point input 30		
AnIn 31	MV_1	GOOSE Floating point input 31		
AnIn 32	MV_1	GOOSE Floating point input 32		
IntIn1	INS_3	GOOSE Integer input 1		
IntIn2	INS_3	GOOSE Integer input 2		
IntIn3	INS_3	GOOSE Integer input 3		
IntIn4	INS_3	GOOSE Integer input 4		

Attribute	Attr. Type	Explanation	T	X
IntIn5	INS_3	GOOSE Integer input 5		
IntIn6	INS_3	GOOSE Integer input 6		
IntIn7	INS_3	GOOSE Integer input 7		
IntIn8	INS_3	GOOSE Integer input 8		
IntIn9	INS_3	GOOSE Integer input 9		
IntIn10	INS_3	GOOSE Integer input 10		
IntIn11	INS_3	GOOSE Integer input 11		
IntIn12	INS_3	GOOSE Integer input 12		
IntIn13	INS_3	GOOSE Integer input 13		
IntIn14	INS_3	GOOSE Integer input 14		
IntIn15	INS_3	GOOSE Integer input 15		
IntIn16	INS_3	GOOSE Integer input 16		
IntIn17	INS_3	GOOSE Integer input 17		
IntIn18	INS_3	GOOSE Integer input 18		
IntIn19	INS_3	GOOSE Integer input 19		
IntIn20	INS_3	GOOSE Integer input 20		
IntIn21	INS_3	GOOSE Integer input 21		
IntIn22	INS_3	GOOSE Integer input 22		
IntIn23	INS_3	GOOSE Integer input 23		
IntIn24	INS_3	GOOSE Integer input 24		
IntIn25	INS_3	GOOSE Integer input 25		
IntIn26	INS_3	GOOSE Integer input 26		
IntIn27	INS_3	GOOSE Integer input 27		
IntIn28	INS_3	GOOSE Integer input 28		
IntIn29	INS_3	GOOSE Integer input 29		
IntIn30	INS_3	GOOSE Integer input 30		
IntIn31	INS_3	GOOSE Integer input 31		
IntIn32	INS_3	GOOSE Integer input 32		
Ind1	SPS_0	GOOSE Binary Input 1		
Ind2	SPS_0	GOOSE Binary Input 2		
Ind3	SPS_0	GOOSE Binary Input 3		
Ind4	SPS_0	GOOSE Binary Input 4		
Ind5	SPS_0	GOOSE Binary Input 5		
Ind6	SPS_0	GOOSE Binary Input 6		
Ind7	SPS_0	GOOSE Binary Input 7		
Ind8	SPS_0	GOOSE Binary Input 8		
Ind9	SPS_0	GOOSE Binary Input 9		
Ind10	SPS_0	GOOSE Binary Input 10		
Ind11	SPS_0	GOOSE Binary Input 11		
Ind12	SPS_0	GOOSE Binary Input 12		
Ind13	SPS_0	GOOSE Binary Input 13		
Ind14	SPS_0	GOOSE Binary Input 14		
Ind15	SPS_0	GOOSE Binary Input 15		
Ind16	SPS_0	GOOSE Binary Input 16		

Attribute	Attr. Type	Explanation	T	X
Ind17	SPS_0	GOOSE Binary Input 17		
Ind18	SPS_0	GOOSE Binary Input 18		
Ind19	SPS_0	GOOSE Binary Input 19		
Ind20	SPS_0	GOOSE Binary Input 20		
Ind21	SPS_0	GOOSE Binary Input 21		
Ind22	SPS_0	GOOSE Binary Input 22		
Ind23	SPS_0	GOOSE Binary Input 23		
Ind24	SPS_0	GOOSE Binary Input 24		
Ind25	SPS_0	GOOSE Binary Input 25		
Ind26	SPS_0	GOOSE Binary Input 26		
Ind27	SPS_0	GOOSE Binary Input 27		
Ind28	SPS_0	GOOSE Binary Input 28		
Ind29	SPS_0	GOOSE Binary Input 29		
Ind30	SPS_0	GOOSE Binary Input 30		
Ind31	SPS_0	GOOSE Binary Input 31		
Ind32	SPS_0	GOOSE Binary Input 32		

3.4.10 Logical Node: GGIO_9

Description: Generic Process I/O – Virtual Output signals

LN Class: GGIO

Attribute	Attr. Type	Explanation	T	X
Mod	INC_0	Mode		
Beh	INS_0	Behaviour		
Health	INS_1	Health		
NamPlt	LPL_0	Name Plate		
Ind1	SPS_0	GOOSE Binary Input 1		
Ind2	SPS_0	GOOSE Binary Input 2		
Ind3	SPS_0	GOOSE Binary Input 3		
Ind4	SPS_0	GOOSE Binary Input 4		
Ind5	SPS_0	GOOSE Binary Input 5		
Ind6	SPS_0	GOOSE Binary Input 6		
Ind7	SPS_0	GOOSE Binary Input 7		
Ind8	SPS_0	GOOSE Binary Input 8		
Ind9	SPS_0	GOOSE Binary Input 9		
Ind10	SPS_0	GOOSE Binary Input 10		
Ind11	SPS_0	GOOSE Binary Input 11		
Ind12	SPS_0	GOOSE Binary Input 12		
Ind13	SPS_0	GOOSE Binary Input 13		
Ind14	SPS_0	GOOSE Binary Input 14		
Ind15	SPS_0	GOOSE Binary Input 15		
Ind16	SPS_0	GOOSE Binary Input 16		
Ind17	SPS_0	GOOSE Binary Input 17		

Attribute	Attr. Type	Explanation	T	X
Ind18	SPS_0	GOOSE Binary Input 18		
Ind19	SPS_0	GOOSE Binary Input 19		
Ind20	SPS_0	GOOSE Binary Input 20		
Ind21	SPS_0	GOOSE Binary Input 21		
Ind22	SPS_0	GOOSE Binary Input 22		
Ind23	SPS_0	GOOSE Binary Input 23		
Ind24	SPS_0	GOOSE Binary Input 24		
Ind25	SPS_0	GOOSE Binary Input 25		
Ind26	SPS_0	GOOSE Binary Input 26		
Ind27	SPS_0	GOOSE Binary Input 27		
Ind28	SPS_0	GOOSE Binary Input 28		
Ind29	SPS_0	GOOSE Binary Input 29		
Ind30	SPS_0	GOOSE Binary Input 30		
Ind31	SPS_0	GOOSE Binary Input 31		
Ind32	SPS_0	GOOSE Binary Input 32		

3.4.11 Logical Node: LLN0_0

Description: General Logical Node 0 (Measurement Domain and Record Domain)

LN Class: LLN0

Attribute	Attr. Type	Explanation	T	X
Mod	INC_0	Mode		
Beh	INS_0	Behavior		
Health	INS_1	Health		
NamPlt	LPL_1	Name Plate		

3.4.12 Logical Node: LLN0_1

Description: General Logical Node 0 (Systems Domain)

LN Class: LLN0

Attribute	Attr. Type	Explanation	T	X
Mod	INC_0	Mode		
Beh	INS_0	Behavior		
Health	INS_1	Health		
NamPlt	LPL_1	Name Plate		

3.4.13 Logical Node: LPHD_0

Description: Mx7x Physical Device Information

LN Class: LPHD

Attribute	Attr. Type	Explanation	T	X
PhyNam	DPL_0	Physical device name plate		
PhyHealth	INS_2	Physical device health		
Proxy	SPS_0	Indicates if this LN is a proxy		
NumPwrUp	INS_3	Number of Power ups		
WrmStr	INS_3	Number of Warm Starts		
WacTrg	INS_3	Number of watchdog device resets detected		

3.4.14 Logical Node: MADV_0 (Custom LN not contained in IEC61850 part 7-4 definitions)

Description: Advanced Measurements

LN Class: MADV (Custom LN Class not contained in IEC61850 part 7-4 definitions)

Attribute	Attr. Type	Explanation	T	X
Mod	INC_0	Mode		
Beh	INS_0	Behavior		
Health	INS_0	Health		
NamPlt	LPL_2	Name Plate		
TotVAa	MV_0	Total VA arithmetic mode		X
TotVAv	MV_0	Total VA vector mode (Geometric)		X
TotVAaFund	MV_0	Total VA Fundamental arithmetic mode		X
TotVAvFund	MV_0	Total VA Fundamental vector mode (Geometric)		X
TotPFa	MV_0	Total power factor arithmetic mode		X
TotPFv	MV_0	Total power factor vector mode (Geometric)		X
DF	WYE_1	Displacement Fundamental power factor		X
TotDFa	MV_0	Total Displacement power factor arithmetic mode		X
TotDFv	MV_0	Total Displacement power factor vector mode (Geometric)		X
Ires	MV_0	Residual current		X

3.4.15 Logical Node: MLFK_0 (Custom LN not contained in IEC61850 part 7-4 definitions)

Description: Flicker Measurements

LN Class: MFLK (Custom LN Class not contained in IEC61850 part 7-4 definitions)

This LN shall be used for calculation of flicker including voltage fluctuations according to IEC Standard 61000-4-15. The main use is for operative applications

Attribute	Attr. Type	Explanation	T	X
Mod	INC_0	Mode		
Beh	INS_0	Behavior		
Health	INS_0	Health		
NamPit	LPL_2	Name Plate		
Pst	DEL_0	Perception Level for Flicker short term Van, Vbn, Vcn, (Bus 1 and Bus 2)		X
Pit	DEL_0	Perception Level for Flicker long term Van, Vbn, Vcn, (Bus 1 and Bus 2)		X
PiMax	DEL_0	Instantaneous Flicker Level (IFL)		X

Note: Delta class (DEL_0) used for multi-phase measurements for WYE or DELTA connections since neutral is not measured for flicker

3.4.16 Logical Node: MFLO_0 (Custom LN not contained in IEC61850 part 7-4 definitions)

Description: Fault Distance Measurement indicates the Fault Location

LN Class: MFLO (Custom LN Class not contained in IEC61850 part 7-4 definitions)

This LN shall be used for calculation of fault location. The main use is for operative applications. Fault location is determined using a single-ended impedance calculation that is based upon an algorithm using measured values. Refer to the M87x or M57x User Manuals for more information pertaining to fault location measurement and triggering.

Attribute	Attr. Type	Explanation	T	X
Mod	INC_0	Mode		
Beh	INS_0	Behavior		
Health	INS_0	Health		
NamPlt	LPL_2	Name Plate		
FltDiskm	MV_0	Fault Distance (Use the 70Series Configurator to program the unit of measure. IEC61850 protocol has standardized on a unit of measure in kilometers. If during configuration another unit of measure is programmed by the user, then the value for Fault Distance will be measured in that unit of measure.)		

3.4.17 Logical Node: MHAI_0

Description: Harmonics or Interharmonics totals - current and voltage (without individual harmonics)

LN Class: MHAI

Attribute	Attr. Type	Explanation	T	X
Mod	INC_0	Mode		
Beh	INS_0	Behavior		
Health	INS_1	Health		
NamPlt	LPL_0	Name Plate		
TddA	WYE_0	Total Current Demand Distortion per IEEE 519		
ThdPhV	WYE_1	Voltage total Harmonic or Interharmonic Distortion for phase to ground		
ThdPPV	DEL_0	Voltage total Harmonic or Interharmonic Distortion for phase to phase		

3.4.18 Logical Node: MHAI_1

Description: Harmonics or Interharmonics totals for voltage only (without individual harmonics))

LN Class: MHAI

Attribute	Attr. Type	Explanation	T	X
Mod	INC_0	Mode		
Beh	INS_0	Behavior		
Health	INS_1	Health		
NamPit	LPL_0	Name Plate		
ThdPhV	WYE_1	Voltage total Harmonic or Interharmonic Distortion for phase to ground		
ThdPPV	DEL_0	Voltage total Harmonic or Interharmonic Distortion for phase to phase		

3.4.19 Logical Node: MHAI_2

Description: Harmonics or Interharmonics totals for Volts and Amps (including individual harmonics, phase related K factor and harmonic demand)

LN Class: MHAI

Attribute	Attr. Type	Explanation	T	X
Mod	INC_0	Mode		
Beh	INS_0	Behavior		
Health	INS_1	Health		
NamPit	LPL_0	Name Plate		
Hz	MV_0	Basic Frequency		
HA	HWYE_0	Phase related sequence of harmonics or interharmonics Current for A,B,C,N,Residual		
HPhV	HWYE_0	Sequence of Harmonics or Interharmonics for phase to ground voltages AN, BN, CN, NG		
HPPV	HDEL_0	Sequence of Harmonics or Interharmonics for phase to phase voltages AB,BC,CA		
HKf	WYE_0	Phase related K factor for A, B, C (Transformer derating)		
TddA	WYE_0	Total Current Demand Distortion (per IEEE 519, phase related)		
TddOddA	WYE_0	Total Current Demand Distortion odd components (per IEEE 519, phase related)		
TddEvnA	WYE_0	Total Current Demand Distortion even components (per IEEE 519, phase related)		
ThdPhV	WYE_1	Voltage total Harmonic or Interharmonic Distortion for phase to ground (phase related)		
ThdOddPhV	WYE_1	Voltage total Harmonic or Interharmonic Distortion for phase to ground (odd components)		
ThdEvnPhV	WYE_1	Voltage total Harmonic or Interharmonic Distortion for phase to ground (even components)		
ThdPPV	DEL_0	Voltage total Harmonic or Interharmonic Distortion for phase to phase		
ThdOddPPV	DEL_0	Voltage total Harmonic or Interharmonic Distortion for phase to phase (odd components)		

Attribute	Attr. Type	Explanation	T	X
ThdEvnPPV	DEL_0	Voltage total Harmonic or Interharmonic Distortion for phase to phase (even components)		
NomA1	ASG_0	Normalizing demand current for Phase A used in IEEE 519 Tdd calculation (Harmonic Denominator)		
NomA2	ASG_0	Normalizing demand current for Phase B used in IEEE 519 Tdd calculation (Harmonic Denominator)		
NomA3	ASG_0	Normalizing demand current for Phase C used in IEEE 519 Tdd calculation (Harmonic Denominator)		
DmdIntH	ASG_1	Integration time for Thermal Demand of Harmonics (seconds)		X
RsDmdH	SPC_0	Reset Thermal Demand of Voltage total harmonic distortion		X

3.4.20 Logical Node: MHAI_3

Description: Harmonics or Interharmonics totals for Volts only (including individual harmonics, and harmonic demand)

LN Class: MHAI

Attribute	Attr. Type	Explanation	T	X
Mod	INC_0	Mode		
Beh	INS_0	Behavior		
Health	INS_1	Health		
NamPlt	LPL_0	Name Plate		
Hz	MV_0	Basic Frequency		
HPhV	HWYE_0	Sequence of Harmonics or Interharmonics phase to ground voltages		
HPPV	HDEL_0	Sequence of Harmonics or Interharmonics phase to phase voltages		
ThdPhV	WYE_1	Voltage total Harmonic or Interharmonic Distortion for phase to ground		
ThdOddPhV	WYE_1	Voltage total Harmonic or Interharmonic Distortion for phase to ground (odd components)		
ThdEvnPhV	WYE_1	Voltage total Harmonic or Interharmonic Distortion for phase to ground (even components)		
ThdPPV	DEL_0	Voltage total Harmonic or Interharmonic Distortion for phase to phase		
ThdOddPPV	DEL_0	Voltage total Harmonic or Interharmonic Distortion for phase to phase (odd components)		
ThdEvnPPV	DEL_0	Voltage total Harmonic or Interharmonic Distortion for phase to phase (even components)		
DmdIntH	ASG_1	Integration time for Thermal Demand of Voltage total harmonic distortion (seconds)		X
RsDmdH	SPC_0	Reset Thermal Demand of Voltage total harmonic distortion		X

3.4.21 Logical Node: MMTR_0

Description: Energy measurements

LN Class: MMTR

Attribute	Attr. Type	Explanation	T	X
Mod	INC_0	Mode		
Beh	INS_0	Behavior		
Health	INS_1	Health		
NamPlt	LPL_0	Name Plate		
TotVAh	BCR_0	Total apparent power since last rest.		
SupWh	BCR_0	Real energy supply (default supply direction energy flow towards busbar)		
SupVArh	BCR_0	Reactive energy supply (default supply direction energy flow towards busbar)		
DmdWh	BCR_0	Real energy demand (default demand direction energy flow away from busbar)		
DmdVArh	BCR_0	Reactive energy demand (default demand direction energy flow away from busbar)		
RsEnergy	SPC_0	Reset Energy		X

3.4.22 Logical Node: MMXN_0

Description: Voltage Measurements not allocated to a phase (Auxilliary or Reference voltages)

LN Class: MMXN_0

Attribute	Attr. Type	Explanation	T	X
Mod	INC_0	Mode		
Beh	INS_0	Behaviour		
Health	INS_1	Health		
NamPlt	LPL_0	Name Plate		
Vol	MV_0	Voltage V (rms) not allocated to a phase (i.e. auxiliary and reference voltages)		

3.4.23 Logical Node: MMXU_0

Description: Standard measurements -
 Present Thermal Demands - Bus 1 (M871)
 Maximum Thermal Demands Bus 1 (M871)

LN Class: MMXU

Attribute	Attr. Type	Explanation	T	X
Mod	INC_0	Mode		
Beh	INS_0	Behaviour		
Health	INS_1	Health		
NamPlt	LPL_0	Name Plate		
TotW	MV_0	Total active power (Total P)		
TotVAr	MV_0	Total reactive power (Total Q)		
TotVA	MV_0	Total apparent power (Total S)		
PPV	DEL_0	Phase to Phase voltages		
PhV	WYE_2	Phase to Ground voltages (A,B,C,N)		
A	WYE_3	Phase Currents (A,B,C,N,Residual)		
W	WYE_1	Phase active power (P)		
VAr	WYE_1	Phase reactive power (Q)		
VA	WYE_1	Phase apparent power (S)		

3.4.24 Logical Node: MMXU_1

Description: Standard measurements –
 Present Thermal Demands - Bus 1 (M571, M572, M872)
 Bus 2 (M572, M872)
 Maximum Thermal Demands - Bus 1 (M571, M572, M872)
 Bus 2 (M572, M872)

LN Class: MMXU

Attribute	Attr. Type	Explanation	T	X
Mod	INC_0	Mode		
Beh	INS_0	Behaviour		
Health	INS_1	Health		
NamPlt	LPL_0	Name Plate		
TotW	MV_0	Total active power (Total P)		
TotVAr	MV_0	Total reactive power (Total Q)		
TotVA	MV_0	Total apparent power (Total S)		
PPV	DEL_0	Phase to Phase voltages		
PhV	WYE_2	Phase to Ground voltages (A,B,C,N)		
A	WYE_0	Phase Currents (A,B,C,Residual)		
W	WYE_1	Phase active power (P)		
VAr	WYE_1	Phase reactive power (Q)		
VA	WYE_1	Phase apparent power (S)		

3.4.25 Logical Node: MMXU_2

Description: Standard measurements –
 Present Thermal Demands, Bus 2 (M571, M871)
 Minimum Thermal Demands, Bus 2 (M571, M871)
 Maximum Thermal Demands Bus 2 (M571, M871)

LN Class: MMXU

Attribute	Attr. Type	Explanation	T	X
Mod	INC_0	Mode		
Beh	INS_0	Behaviour		
Health	INS_1	Health		
NamPlt	LPL_0	Name Plate		
PPV	DEL_0	Phase to Phase voltages		
PhV	WYE_2	Phase to Ground voltages (A,B,C,N)		

3.4.26 Logical Node: MMXU_3

Description: Standard measurements –
 Minimum Thermal Demands, Bus 1 (M571, M572,M871, M872)
 Bus 2 (M572, M872)

LN Class: MMXU

Attribute	Attr. Type	Explanation	T	X
Mod	INC_0	Mode		
Beh	INS_0	Behaviour		
Health	INS_1	Health		
NamPlt	LPL_0	Name Plate		
TotW	MV_0	Total active power (Total P)		
TotVAr	MV_0	Total reactive power (Total Q)		
TotVA	MV_0	Total apparent power (Total S)		
PPV	DEL_0	Phase to Phase voltages		
PhV	WYE_2	Phase to Ground voltages (A,B,C,N)		
W	WYE_1	Phase active power (P)		
VAr	WYE_1	Phase reactive power (Q)		
VA	WYE_1	Phase apparent power (S)		

3.4.27 Logical Node: MMXU_4

Description: Standard measurements –

Fundamental Thermal Demands,
 Maximum Fundamental Thermal Demands for Bus 1 (M871)

LN Class: MMXU

Attribute	Attr. Type	Explanation	T	X
Mod	INC_0	Mode		
Beh	INS_0	Behaviour		
Health	INS_1	Health		
NamPlt	LPL_0	Name Plate		
A	WYE_3	Phase Currents (A,B,C,N,Residual)		

3.4.28 Logical Node: MMXU_5

Description: Standard measurements –

Fundamental Thermal Demands,
 Maximum Fundamental Thermal Demands - Bus 1 (M571, M572, M872),

Fundamental Thermal Demands,
 Maximum Fundamental Thermal Demands for Bus 2 (M572, M872)

Note: Bus 2 (M571, M871) will not measure either Fundamental Thermal Demands or Maximum Fundamental Thermal Demands since Bus 2 current is absent in those devices.

LN Class: MMXU

Attribute	Attr. Type	Explanation	T	X
Mod	INC_0	Mode		
Beh	INS_0	Behaviour		
Health	INS_1	Health		
NamPlt	LPL_0	Name Plate		
A	WYE_0	Phase Currents (A,B,C,Residual)		

3.4.29 Logical Node: MMXU_6

Description: Standard measurements – Fundamental (Fourier) Values for Bus 1 (M871)

LN Class: MMXU

Attribute	Attr. Type	Explanation	T	X
Mod	INC_0	Mode		
Beh	INS_0	Behaviour		
Health	INS_1	Health		
NamPIt	LPL_0	Name Plate		
TotW	MV_0	Total active power (Total P)		
TotVAr	MV_0	Total reactive power (Total Q)		
TotVA	MV_0	Total apparent power (Total S)		
TotPF	MV_0	Average power factor (Total PF)		
Hz	MV_0	Frequency		
PPV	DEL_0	Phase to Phase voltages (AB,BC,CA)		
PhV	WYE_1	Phase to Ground voltages (A,B,C)		
A	WYE_3	Phase Currents (A,B,C,N,Residual)		
W	WYE_1	Phase active power (P)		
VAr	WYE_1	Phase reactive power (Q)		
VA	WYE_1	Phase apparent power (S)		
PF	WYE_1	Phase power factor		

3.4.30 Logical Node: MMXU_7

Description: Standard measurements –Fundamental (Fourier) Values for
 Bus 1 (M571, M572, M872) or
 Bus 2 (M572, M872)

LN Class: MMXU

Attribute	Attr. Type	Explanation	T	X
Mod	INC_0	Mode		
Beh	INS_0	Behaviour		
Health	INS_1	Health		
NamPIt	LPL_0	Name Plate		
TotW	MV_0	Total active power (Total P)		
TotVAr	MV_0	Total reactive power (Total Q)		
TotVA	MV_0	Total apparent power (Total S)		
TotPF	MV_0	Average power factor (Total PF)		
Hz	MV_0	Frequency		
PPV	DEL_0	Phase to Phase voltages		
PhV	WYE_1	Phase to Ground voltages (A.B.C)		
A	WYE_0	Phase Currents (A,B,C,Residual)		
W	WYE_1	Phase active power (P)		
VAr	WYE_1	Phase reactive power (Q)		
VA	WYE_1	Phase apparent power (S)		
PF	WYE_1	Phase power factor		

3.4.31 Logical Node: MMXU_8

Description: Standard measurements – Fundamental (Fourier) Values for Bus 2, Volts only (M571,M871)

LN Class: MMXU

Attribute	Attr. Type	Explanation	T	X
Mod	INC_0	Mode		
Beh	INS_0	Behaviour		
Health	INS_1	Health		
NamPlt	LPL_0	Name Plate		
Hz	MV_0	Frequency		
PPV	DEL_0	Phase to Phase voltages		
PhV	WYE_1	Phase to Ground voltages (A.B.C)		

3.4.32 Logical Node: MMXU_9

Description: Standard measurements – Bus 1 (M871)

LN Class: MMXU

Attribute	Attr. Type	Explanation	T	X
Mod	INC_0	Mode		
Beh	INS_0	Behaviour		
Health	INS_1	Health		
NamPlt	LPL_0	Name Plate		
TotW	MV_0	Total active power (Total P)		
TotVAr	MV_0	Total reactive power (Total Q)		
TotVA	MV_0	Total apparent power (Total S)		
TotPF	MV_0	Average power factor (Total PF)		
Hz	MV_0	Frequency		
PPV	DEL_0	Phase to Phase voltages (AB,BC,CA)		
PhV	WYE_2	Phase to Ground voltages (A,B,C,N)		
A	WYE_3	Phase Currents (A,B,C,N,Residual)		
W	WYE_1	Phase active power (P)		
VAr	WYE_1	Phase reactive power (Q)		
VA	WYE_1	Phase apparent power (S)		
PF	WYE_1	Phase power factor		
Z	WYE_1	Phase Impedance		
DmdIntA	ASG_1	Integration time (interval) for Thermal Demand Current		X
DmdIntP	ASG_1	Integration time (interval) for Thermal Demand Power		X
DmdIntV	ASG_1	Integration time (interval) for Thermal Demand Voltage		X
RsDmdA	SPC_0	Reset of Thermal Demand Current		X
RsDmdP	SPC_0	Reset of Thermal Demand Power		X
RsDmdV	SPC_0	Reset of Thermal Demand Voltage		X

3.4.33 Logical Node: MMXU_10

Description: Standard measurements – Bus 1 (M571, M572, M872) or
 Standard measurements – Bus 2 (M572, M872)

LN Class: MMXU

Attribute	Attr. Type	Explanation	T	X
Mod	INC_0	Mode		
Beh	INS_0	Behaviour		
Health	INS_1	Health		
NamPlt	LPL_0	Name Plate		
TotW	MV_0	Total active power (Total P)		
TotVAr	MV_0	Total reactive power (Total Q)		
TotVA	MV_0	Total apparent power (Total S)		
TotPF	MV_0	Average power factor (Total PF)		
Hz	MV_0	Frequency		
PPV	DEL_0	Phase to Phase voltages (AB,BC,CA)		
PhV	WYE_2	Phase to Ground voltages (A B,C,N)		
A	WYE_0	Phase Currents (A,B,C,Residual)		
W	WYE_1	Phase active power (P)		
,VAr	WYE_1	Phase reactive power (Q)		
VA	WYE_1	Phase apparent power (S)		
PF	WYE_1	Phase power factor		
Z	WYE_1	Phase Impedance		X
DmdIntA	ASG_1	Integration time (interval) for Thermal Demand Current		X
DmdIntP	ASG_1	Integration time (interval) for Thermal Demand Power		X
DmdIntV	ASG_1	Integration time (interval) for Thermal Demand Voltage		X
RsDmdA	SPC_0	Reset of Thermal Demand Current		X
RsDmdP	SPC_0	Reset of Thermal Demand Power		X
RsDmdV	SPC_0	Reset of Thermal Demand Voltage		X

3.4.34 Logical Node: MMXU_11

Description: Standard measurements – Bus 2 (M571, M871)

LN Class: MMXU

Attribute	Attr. Type	Explanation	T	X
Mod	INC_0	Mode		
Beh	INS_0	Behaviour		
Health	INS_1	Health		
NamPlt	LPL_0	Name Plate		
Hz	MV_0	Frequency		
PPV	DEL_0	Phase to Phase voltages(AB,BC,CA)		
PhV	WYE_2	Phase to Ground voltages (A,B,C,N)		X
DmdIntA	ASG_1	Integration time (interval) for Thermal Demand Current		X
DmdIntP	ASG_1	Integration time (interval) for Thermal Demand Power		X
DmdIntV	ASG_1	Integration time (interval) for Thermal Demand Voltage		X
RsDmdA	SPC_0	Reset of Thermal Demand Current		X
RsDmdP	SPC_0	Reset of Thermal Demand Power		X
RsDmdV	SPC_0	Reset of Thermal Demand Voltage		X

3.4.35 Logical Node: MSQI_0

Description: Sequence and imbalance for Volts and Amps (Pos, Neq, Zero)

LN Class: MSQI

Attribute	Attr. Type	Explanation	T	X
Mod	INC_0	Mode		
Beh	INS_0	Behaviour		
Health	INS_1	Health		
NamPlt	LPL_0	Name Plate		
SeqA	SEQ_0	Positive, Negative and Zero Sequence Current		
SeqV	SEQ_0	Positive, Negative and Zero Sequence Voltage		
ImbNgA	MV_0	Imbalance negative sequence current		
ImbNgV	MV_0	Imbalance negative sequence voltage		
ImbZroA	MV_0	Imbalance zero sequence current		
ImbZroV	MV_0	Imbalance zero sequence voltage		

3.4.36 Logical Node: MSQI_1

Description: Sequence and imbalance for Voltage only (Pos, Neg, Zero)

LN Class: MSQI

Attribute	Attr. Type	Explanation	T	X
Mod	INC_0	Mode		
Beh	INS_0	Behaviour		
Health	INS_1	Health		
NamPlt	LPL_0	Name Plate		
SeqV	SEQ_0	Positive, Negative and Zero Sequence Voltage		
ImbNgV	MV_0	Imbalance negative sequence voltage		
ImbZroV	MV_0	Imbalance zero sequence voltage		

3.4.37 Logical Node: MSYN_0 (Custom LN not contained in IEC61850 part 7-4 definitions)

Description: Synchronism check (this LN is customized from RSYN, but is different)

LN Class: MSYN (Custom LN Class not contained in IEC61850 part 7-4 definitions)

Attribute	Attr. Type	Explanation	T	X
Mod	INC_0	Mode		
Beh	INS_0	Behavior		
Health	INS_0	Health		
NamPlt	LPL_2	Name Plate		
DifVClc	MV_0	Calculated difference in Voltage		
DifHzClc	MV_0	Calculated difference in Frequency		
DifAngClc	MV_0	Calculated difference in Phase Angle		

3.4.38 Logical Node: MTMP_0 (Custom LN not contained in IEC61850 part 7-4 definitions)

Description: Internal Ambient Temperature of Logical Device

LN Class: MTMP (Custom LN Class not contained in IEC61850 part 7-4 definitions)

Attribute	Attr. Type	Explanation	T	X
Mod	INC_0	Mode		
Beh	INS_0	Behavior		
Health	INS_0	Health		
NamPlt	LPL_2	Name Plate		
TmpVal	MV_0	Value for internal ambient Temperature in degree C		X

3.4.39 Logical Node: RDRE_0

Description: Disturbance Recorder function (Mx70 disturbance and waveform recorders))

LN Class: RDRE

Attribute	Attr. Type	Explanation	T	X
Mod	INC_0	Mode		
Beh	INS_0	Behaviour		
Health	INS_1	Health		
NamPlt	LPL_0	Name Plate		
RcdTrg	SPC_1	Trigger recorder (Manual trigger)		
RcdMade	SPS_0	Recording made		
FltNum	INS_3	Fault number		
RcdStr	SPS_0	Recording started		
MemUsed	INS_3	Memory Used in %		
PreTmms	ING_0	Pre-trigger time (msec)		
PstTmms	ING_0	Post-trigger time (msec)		
MemFull	ING_0	Memory Full level		
OpMod	ING_1	Operate Mode (Stop on full = 1, Overwrite = 2)		
FullSt	SPS_1	Recorder status is full		

3.4.40 Logical Node: TCTR_0

Description: Current Transformer

LN Class: TCTR

Attribute	Attr. Type	Explanation	T	X
Mod	INC_0	Mode		
Beh	INS_0	Behaviour		
Health	INS_1	Health		
NamPlt	LPL_0	Name Plate		
Rat	ASG_0	Winding ratio of an external current transformer (transducer)		
Cor	ASG_0	Current phasor magnitude correction of an external current transformer		
AngCor	ASG_0	Current phasor angle correction of an external current transformer		

3.4.41 Logical Node: TVTR_0

Description: Voltage Transformer

LN Class: TVTR

Attribute	Attr. Type	Explanation	T	X
Mod	INC_0	Mode		
Beh	INS_0	Behaviour		
Health	INS_1	Health		
NamPlt	LPL_0	Name Plate		
Rat	ASG_0	Winding ratio of an external voltage transformer (transducer)		
Cor	ASG_0	Magnitude correction of an external voltage transformer		
AngCor	ASG_0	Phase Angle correction of an external voltage transformer		

3.5 Common Data Class definitions

The definition tables for each of the Common Data Classes used in the Logical Node definitions are presented in the following sub-sections.

From an application point-of-view the data attributes of a Common Data Class are classified according to their specific use. The characterization of data attributes, and the services that they support/provide, will be through the use of 'Functional Constraints'. The Functional Constraints are specified by the table below:

FC Name	Semantic	Source Definition
BR	Buffered reports	IEC61850-7-2
CF	Configuration	IEC61850-7-2
CO	Control	IEC61850-7-2
DC	Description	IEC61850-7-2
EX	Extended Definition	IEC61850-7-2
GO	GOOSE Control	IEC61850-7-2
GS	GSSE Control (UCA2 GOOSE) – NOT USED in Mx70 devices	IEC61850-7-2
LG	Logging – NOT USED in Mx70 devices	IEC61850-7-2
MS	Multicast sampled value control – NOT USED in Mx70 devices	IEC61850-7-2
MX	Measurands (Analogue values)	IEC61850-7-2
RP	Unbuffered reports	IEC61850-7-2
SE	Setting Group Editable – NOT USED in Mx70 devices	IEC61850-7-2
SG	Setting Group	IEC61850-7-2
SP	Set Point	IEC61850-7-2
ST	Status Information	IEC61850-7-2
SV	Substitution Values – NOT USED in Mx70 devices	IEC61850-7-2
US	Unicast sampled value control – NOT USED in Mx70 devices	IEC61850-7-2
XX	Data attribute service parameters	IEC61850-7-2

To elaborate on the data “types” used in the common data classes (or CDCs), the data attributes, as defined in the tables, reflect the revised attribute “types” in order to correspond

with the data having either an interger value of 32 bits (INT32), or an enumerated value of 8 bits (ENUMERTED8). The attribute “types” defined for the common data classes, INC, ING and INS, have been revised, with the values shown in parentheses to indicate the types that have been replaced in standard IEC61850, 1st edition. It was necessary to eliminate some confusion that existed in the data definitions. The corresponding data objects of Mod, Beh, Health, and PhyHealth use the enumerated versions for the CDCs. All other uses of the 3 CDCs use the INT32 version. An 8 bit enumeration is possible, because all enumerations (so far) have less the 128 possible standardized values.

3.5.1 Common Data Class: ASG_0

Description: Analogue Setting

CDC Class: ASG

Attribute	Type	FC	Enumeration	Comment	X
setMag	AnalogueValue_0	SP		AnalogueValue	
d	VISIBLE_STRING255	DC		Description of the status element. Textual description of the data	

3.5.2 Common Data Class: ASG_1

Description: Analogue Setting for Bitronics non standard data class

CDC Class: ASG

Attribute	Type	FC	Enumeration	Comment	X
setMag	AnalogueValue_0	SP		AnalogueValue	
d	VISIBLE_STRING255	DC		Description of the status element. Textual description of the data	
dataNs	VISIBLE_STRING255	EX		Data name space	

3.5.3 Common Data Class: BCR_0

Description: Binary counter reading

CDC Class: BCR

Attribute	Type	FC	Enumeration	Comment	X
actVal	INT64	ST		Binary counter status is a 64 bit Interger value.	
q	Quality	ST		Quality of the measurement value	
t	TimeStamp	ST		Time deadbanded magnitude last exceeded its db configuration parameter	
pulsQty	FLOAT32	CF		Engineering units = PulsQty x actVal	
d	VISIBLE_STRING255	DC		Description of the status element. Textual description of the data	

3.5.4 Common Data Class: CMV_0

Description: Complex Measured value (Floating Point Magnitude)

CDC Class: CMV

Attribute	Type	FC	Enumeration	Comment	X
instCVal	Vector_0	MX		Instantaneous complex measured vector	
cVal	Vector_0	MX		Deadbanded Complex measured vector value (Magnitude only), however, the value of cVal is updated to the current value of instCVal. cVal will track to instCVal since deadbanded values aren't supported in Mx70 devices. Note: Deadbanded analog measured value changes do not trigger GOOSE messaging nor reports.	
q	Quality	MX		Quality of the measurement value	
t	TimeStamp	MX		Measured value Timestamp	

3.5.5 Common Data Class: CMV_1

Description: Complex Measured value (Floating Point Magnitude and Angle))

CDC Class: CMV

Attribute	Type	FC	Enumeration	Comment	X
instCVal	Vector_1	MX		Instantaneous complex measured vector	
cVal	Vector_1	MX		Deadbanded Complex measured vector value (Magnitude and Phase), however, the value of cVal is updated to the current value of instCVal. cVal will track to instCVal since deadbanded values aren't supported in Mx70 devices. Note: Deadbanded analog measured value changes do not trigger GOOSE messaging nor reports.	
q	Quality	MX		Quality of the measurement value	
t	TimeStamp	MX		Measured value Timestamp	

3.5.6 Common Data Class: DEL_0

Description: Phase to phase measurements for a 3-Phase system

CDC Class: DEL

Attribute	Type	FC	Enumeration	Comment	X
phsAB	CMV_0	--		Measurement values for Phase A to Phase B	
phsBC	CMV_0	--		Measurement values for Phase B to Phase C	
phsCA	CMV_0	--		Measurement values for Phase C to Phase A	
d	VISIBLE_STRING255	DC		Description of the status element. Textual description of the data	

3.5.7 Common Data Class: DPL_0

Description: Standard Device Name Plate

CDC Class: DPL

Attribute	Type	FC	Enumeration	Comment	X
vendor	VISIBLE_STRING255	DC		Name of the vendor	
hwRev	VISIBLE_STRING255	DC		Hardware revision	
swRev	VISIBLE_STRING255	DC		Software revision	
serNum	VISIBLE_STRING255	DC		Serial Number	
model	VISIBLE_STRING255	DC		Model Number	
location	VISIBLE_STRING255	DC		Physical location of device	

3.5.8 Common Data Class: HWYE_0

Description: Phase to Ground harmonics measurements for a 3 phase system

CDC Class: HWYE

Harmonic value for Wye represents the harmonic content of phase-to-neutral and neutral-to-ground quantities. Both magnitudes and phase angles are represented as arrays of floating point quantities. The first index (index=0) of each array represents the DC component and index=N represents the component at $FREQ = N * f$, where "f" is the fundamental frequency.

Attribute	Type	FC	Enumeration	Comment	X
q	Quality	MX		The quality of the status value	
t	TimeStamp	MX		Timestamp of the last change in state	
phsAHar	Vector_1[64]	MX		Magnitude and Angle of all (64) phase A harmonics	
phsBHar	Vector_1[64]	MX		Magnitude and Angle of all (64) phase B harmonics	
phsCHar	Vector_1[64]	MX		Magnitude and Angle of all (64)phase C harmonics	
numHar	INT16U	CF		Number of harmonic values	
evalTm	INT16U	CF		Time window applied to interharmonic calculations. Value is in ms.	
frequency	FLOAT32	CF		Frequency	
hvRef	ENUMERATED8	CF	hvRef	Reference type (i.e.ratio of harmonic to fundamental., to RMS, or to absolute)	
numCyc	INT16U	CF		Number of cycles of power frequency used for harmonic calculation	
d	VISIBLE_STRING255	DC		Description of the status element. Textual description of the data	

3.5.9 Common Data Class: HDEL_0

Description: Phase to Phase harmonics measurements for a 3 phase system

CDC Class: HWYE

The Harmonic value for Delta represents the harmonic content of phase-to-phase quantities. Both magnitudes and phase angles are represented as arrays of floating point quantities. The first index (index=0) of each array represents the DC component and index=N represents the component at $FREQ = N * f$, where "f" is the fundamental frequency.

Attribute	Type	FC	Enumeration	Comment	X
q	Quality	MX		The quality of the status value	
t	TimeStamp	MX		Timestamp of the last change in state	
phsABHar	Vector_1[64]	MX		Magnitude and Angle of all (64) phase A harmonics	
phsBCHar	Vector_1[64]	MX		Magnitude and Angle of all (64) phase B harmonics	
phsCAHar	Vector_1[64]	MX		Magnitude and Angle of all (64) phase C harmonics	
numHar	INT16U	CF		Number of harmonic values	
evalTm	INT16U	CF		Time window applied to interharmonic calculations. Value is in ms.	
frequency	FLOAT32	CF		Frequency	
hvRef	ENUMERATED8	CF	hvRef	Reference type (i.e. ratio of harmonic to fundamental., to RMS, or to absolute)	
numCyc	INT16U	CF		Number of cycles of power frequency used for harmonic calculation	
d	VISIBLE_STRING255	DC		Description of the status element. Textual description of the data	

3.5.10 Common Data Class: INC_0

Description: Controllable Enumerated Status (used for Logical Node Mode control)

CDC Class: INC

Attribute	Type	FC	Enumeration	Comment	X
stVal	ENUMERATED8 (MMS Type: INT8)	ST	Mod	The element status	
q	Quality	ST		Quality of the status value	
t	TimeStamp	ST		Timestamp of the last change in state of status value	
ctlModel	ENUMERATED8 (MMS Type: INT8)	CF	ctlModel	Control model (Corresponding to the behavior of the data)	

3.5.11 Common Data Class: ING_0

Description: Integer Set Point (32 bits)

CDC Class: ING

Attribute	Type	FC	Enumeration	Comment	X
stVal	INT32 (MMS Type: INT32)	SP		The element status	
d	VISIBLE_STRING255	DC		Description of the status element. Textual description of the data	

3.5.12 Common Data Class: ING_1

Description: Enumerated Set Point (8 bits)

CDC Class: ING

Attribute	Type	FC	Enumeration	Comment	X
stVal	ENUMERATED8 (MMS Type: INT8)	SP		The element status	
d	VISIBLE_STRING255	DC		Description of the status element. Textual description of the data	

3.5.13 Common Data Class: INS_0 (Ed2: Dataclass would be called ENS_0)

Description: Enumerated Status (for Behavior)

CDC Class: INS

Attribute	Type	FC	Enumeration	Comment	X
stVal	ENUMERATED8 (MMS Type: INT8)	ST	Beh	The element status	
q	Quality	ST		The quality of the status value	
t	TimeStamp	ST		Timestamp of the last change in state	

3.5.14 Common Data Class: INS_1 (Ed2: Dataclass would be called ENS_1)

Description: Enumerated Status (for Health)

CDC Class: INS

Attribute	Type	FC	Enumeration	Comment	X
stVal	ENUMERATED8 (MMS Type: INT8)	ST	Health	The element status	
q	Quality	ST		The quality of the status value	
t	TimeStamp	ST		Timestamp of the last change in state	

3.5.15 Common Data Class: INS_2 (Ed2: Dataclass would be called ENS_2)

Description: Enumerated Status (for Physical Device Health

CDC Class: INS

Attribute	Type	FC	Enumeration	Comment	X
stVal	ENUMERATED8 (MMS Type: INT8)	ST	PhyHealth	The element status	
q	Quality	ST		The quality of the status value	
t	TimeStamp	ST		Timestamp of the last change in state	
d	VISIBLE_STRING255	DC		Description of the status element. Textual description of the data	

3.5.16 Common Data Class: INS_3

Description: Integer Status 32 bits

CDC Class: INS

Attribute	Type	FC	Enumeration	Comment	X
stVal	INT32 (MMS Type: INT32)	ST		The element status	
q	Quality	ST		The quality of the status value	
t	TimeStamp	ST		Timestamp of the last change in state	
d	VISIBLE_STRING255	DC		Description of the status element. Textual description of the data	

3.5.17 Common Data Class: LPL_0

Description: Standard (or Basic) Logical Node Name Plate for the Measurements Logical Device

CDC Class: LPL

Attribute	Type	FC	Enumeration	Comment	X
vendor	VISIBLE_STRING255	DC		Name of the vendor	
swRev	VISIBLE_STRING255	DC		Software revision	
d	VISIBLE_STRING255	DC		Description - a text string that refers to the logical node	

3.5.18 Common Data Class: LPL_1

Description: Logical Node 0 Name Plate

CDC Class: LPL

Attribute	Type	FC	Enumeration	Comment	X
vendor	VISIBLE_STRING255	DC		Name of the vendor	
swRev	VISIBLE_STRING255	DC		Software revision	
d	VISIBLE_STRING255	DC		Description - a text string that refers to the logical node	
configRev	VISIBLE_STRING255	DC		Uniquely identifies the configuration of a local device instance	
ldNs	VISIBLE_STRING255	EX		Logical Device name space	

3.5.19 Common Data Class: LPL_2

Description: Bitronics Non-Standard Logical Node Name Plate

CDC Class: LPL

Attribute	Type	FC	Enumeration	Comment	X
vendor	VISIBLE_STRING255	DC		Name of the vendor	
swRev	VISIBLE_STRING255	DC		Software revision	
d	VISIBLE_STRING255	DC		Description - a text string that refers to the logical node	
ldNs	VISIBLE_STRING255	EX		Logical Device name space	

3.5.20 Common Data Class: MV_0

Description: Measured deadbanded and instantaneous values (Floating Point values

CDC Class: MV

Attribute	Type	FC	Enumeration	Comment	X
instMag	AnalogueValue_0	MX		Magnitude of the instantaneous measured value.	
mag	AnalogueValue_0	MX		Deadbanded magnitude of the instantaneous value of a measured value or harmonic value. Updated to the current value of instMag when the value has changed according to the configuration parameter db (since Mx70 devices do not support deadband values the mag value will track the instMag value). However, Mx70 devices will not trigger GOOSE messages or reports based upon analogue value changes. Trigger conditions can be set at time of configuration.	X
q	Quality	MX		Quality of the measurement value	
t	TimeStamp	MX		Time deadbanded magnitude last exceeded its db configuration parameter	
d	VISIBLE_STRING255	DC		Description of the status element. Textual description of the data	

3.5.21 Common Data Class: MV_1

Description: Measured value (Floating Point value)

CDC Class: MV

Attribute	Type	FC	Enumeration	Comment	X
mag	AnalogueValue_0	MX		Deadbanded magnitude of the instantaneous value of a measured value or harmonic value. Updated to the current value of instMag when the value has changed according to the configuration parameter db (since Mx70 devices do not support deadband values the mag value will track the instMag value). However, Mx70 devices will not trigger GOOSE messages or reports based upon analogue value changes. Trigger conditions can be set at time of configuration.	X
q	Quality	MX		Quality of the measurement value	
t	TimeStamp	MX		Time deadbanded magnitude last exceeded its db configuration parameter	
d	VISIBLE_STRING255	DC		Description of the status element. Textual description of the data	

3.5.22 Common Data Class: SEQ_0

Description: Sequence components of a measurement value (includes Magnitudes + Angles)

CDC Class: SEQ

Attribute	Type	FC	Enumeration	Comment	X
c1	CMV_1	--		Sequence component 1 (Positive)	
c2	CMV_1	--		Sequence component 2 (Negative)	
c3	CMV_1	--		Sequence component 3 (Zero)	
seqT	ENUMERATED8 (MMS Type: INT8)	MX	seqT	Sequence quantity measurement type (Pos-Neg-Zero or Dir-Quad-Zero)	
d	VISIBLE_STRING255	DC		Description of the status element. Textual description of the data	

3.5.23 Common Data Class: SPC_0

Description: Controllable Single Point - Bitronics non standard data object
 Controllable Single Point that allows only Direct Operate with normal security.

CDC Class: SPC

Attribute	Type	FC	Enumeration	Comment	X
Oper	Oper BOOL_0	CO		Direct Operate control ,On or Off	
stVal	BOOLEAN	ST		Status value of the data	
q	Quality	ST		Quality of the status value	
t	TimeStamp	ST		Timestamp of the last change in state of status value	
stSeld	BOOLEAN	ST		The controllable data is in the status "selected".	
ctlModel	ENUMERATED8 (MMS Type: INT8)	CF	ctlModel	Control model (Corresponding to the behaviour of the data)	
d	VISIBLE_STRING255	DC		Description of the status element. Textual description of the data	
dataNs	VISIBLE_STRING255	EX		Data name space	

3.5.24 Common Data Class: SPC_1

Description: Controllable Single Point - Direct operate with normal security only

CDC Class: SPC

Attribute	Type	FC	Enumeration	Comment	X
Oper	Oper BOOL_0	CO		Direct Operate Boolean control ,On or Off	
stVal	BOOLEAN	ST		Status value of the data	
q	Quality	ST		Quality of the status value	
t	TimeStamp	ST		Timestamp of the last change in state of status value	
stSeld	BOOLEAN	ST		The controllable data is in the status "selected".	
ctlModel	ENUMERATED8 (MMS Type: INT8)	CF	ctlModel	Control model (Corresponding to the behaviour of the data)	
d	VISIBLE_STRING255	DC		Description of the status element. Textual description of the data	

3.5.25 Common Data Class: SPC_3

Description: Controllable Single Point – Direct Operate or SBO with normal security (Digital Outputs option)

CDC Class: SPC

Attribute	Type	FC	Enumeration	Comment	X
SBO	VISIBLE_STRING64	CO		Control data name is Select before operate (SBO)	
Oper	Oper BOOL_0	CO		The operate request that initiates the control operation. On receipt of the operate request , the control object shall check validation of the control execution: <ul style="list-style-type: none"> • If not successful, the control object shall issue a negative response to the requesting client • If successful, the control object shall issue a positive response to the requesting client and cause the requested action 	
Cancel	CancelBOOL_0	CO		The operation request to cancel the control function	
stVal	BOOLEAN	ST		Status value of the data	
q	Quality	ST		Quality of the status value	
t	TimeStamp	ST		Timestamp of the last change in state of status value	
stSeld	BOOLEAN	ST		The controllable data is in the status "selected".	
ctlModel	ENUMERATED8 (MMS Type: INT8)	CF	ctlModel	Control model (Corresponding to the behaviour of the data)	
sboTimeout	INT32U	CF		Set before operate (SBO) timeout setting.in ms. sboTimeout is specified according to the control model that corresponds to the behaviour of the data.	
sboClass	Enumerated8	CF		Select before operate (SBO) class –operate once or operate many. sboClass is specified according to the control model that corresponds to the behaviour of the data.	
d	VISIBLE_STRING255	DC		Description of the status element. Textual description of the data	

3.5.26 Common Data Class: SPS_0

Description: Standard Single Point Status

CDC Class: SPS

Attribute	Type	FC	Enumeration	Comment	X
stVal	BOOLEAN	ST		The element status (TRUE or FALSE)	
q	Quality	ST		The quality of the status value	
t	TimeStamp	ST		Timestamp of the last change in state	
d	VISIBLE_STRING255	DC		Description of the status element. Textual description of the data	

3.5.27 Common Data Class: SPS_1

Description: Single Point Status - Bitronics non standard data object

CDC Class: SPS

Attribute	Type	FC	Enumeration	Comment	X
stVal	BOOLEAN	ST		The element status (TRUE or FALSE)	
q	Quality	ST		The quality of the status value	
t	TimeStamp	ST		Timestamp of the last change in state	
d	VISIBLE_STRING255	DC		Description of the status element. Textual description of the data	
dataNs	VISIBLE_STRING255	EX		Data name space	

3.5.28 Common Data Class: WYE_0

Description: Phase to ground measurements for a 3-Phase system (Phase A,B,C + Residual) including Description

CDC Class: WYE

Attribute	Type	FC	Enumeration	Comment	X
phsA	CMV_0	--		Measurement values for Phase A	
phsB	CMV_0	--		Measurement values for Phase B	
phsC	CMV_0	--		Measurement values for Phase C	
res	CMV_0			Measurement values for residual	
d	VISIBLE_STRING255	DC		Description of the status element. Textual description of the data	

3.5.29 Phase A,B,C + Neutral Common Data Class: WYE_1

Description: Phase to ground measurements for a 3-Phase system (Phase A,B,C + Description)

CDC Class: WYE

Attribute	Type	FC	Enumeration	Comment	X
phsA	CMV_0	--		Measurement values for Phase A	
phsB	CMV_0	--		Measurement values for Phase B	
phsC	CMV_0	--		Measurement values for Phase C	
d	VISIBLE_STRING255	DC		Description of the status element. Textual description of the data	

3.5.30 Common Data Class: WYE_2

Description: Phase to ground measurements for a 3-Phase system (Phase A,B,C + Neutral) including Description

CDC Class: WYE

Attribute	Type	FC	Enumeration	Comment	X
phsA	CMV_0	--		Measurement values for Phase A	
phsB	CMV_0	--		Measurement values for Phase B	
phsC	CMV_0	--		Measurement values for Phase C	
neut	CMV_0	--		Measurement values for neutral input	
d	VISIBLE_STRING255	DC		Description of the status element. Textual description of the data	

3.5.31 Common Data Class: WYE_3

Description: Phase to ground measurements for a 3-Phase system (Phase A,B,C + Neutral + Residual) including Description

CDC Class: WYE

Attribute	Type	FC	Enumeration	Comment	X
phsA	CMV_0	--		Measurement values for Phase A	
phsB	CMV_0	--		Measurement values for Phase B	
phsC	CMV_0	--		Measurement values for Phase C	
neut	CMV_0	--		Measurement values for neutral input	
res	CMV_0			Measurement values for residual	
d	VISIBLE_STRING255	DC		Description of the status element. Textual description of the data	

3.6 Common data attribute type definitions

Common data attribute types, known herein as components, are defined for use in the Common Data Classes defined in the sections above.

3.6.1 Component: AnalogueValue_0

Comment: General analogue value (Floating Point)

Parent Type: AnalogueValue

Attribute	Type	Enumeration	Comment	X
f	FLOAT32		Floating point value	

3.6.2 Component: CancelBOOL_0

Comment: (Control) Cancel

Parent Type: Cancel

Attribute	Type	Enumeration	Comment	X
ctlVal	BOOLEAN		Logical True/False control value	
origin	Originator_0		Origin	
ctlNum	INT8U		8-bit unsigned integer value	
T	Timestamp		Timestamp of Entry Time– This control timestamp is the time when the client sends the control request.	
Test	BOOLEAN		Logical True/False value. No-test (False) / Test (True). Defines whether the information is caused by normal operation or by test.	

3.6.3 Component: Originator_0

Comment: General analogue value that contains information related to the originator of the last change of the controllable value of the data.

Parent Type: Origin

Attribute	Type	Enumeration	Comment	X
orCat	Enumerated8		8-bit Enumerated value	
orIdent	OCTET_STRING64		64 character string (8 bits per character)	

3.6.4 Component: OperBOOL_0

Comment: (Control) Operate (BOOLEAN control value)

Parent Type: Oper

Attribute	Type	Enumeration	Comment	X
ctlVal	BOOLEAN		Logical True/False control value	
origin	Originator_0		Origin	
ctlNum	INT8U		8-bit unsigned integer value	
T	Timestamp		Timestamp of Entry Time– This control timestamp is the time when the client sends the control request.	
Test	BOOLEAN		Logical True/False value. No-test (False) / Test (True). Defines whether the information is caused by normal operation or by test.	
Check	Check		Check –specifies the kind of checks a control object shall perform before issuing the control operation.	

3.6.5 Component: Vector_0

Comment: Complex vector (Floating Point Magnitude value)

Parent Type: Vector

Attribute	Type	Enumeration	Comment	X
mag	AnalogueValue_0		The magnitude of the complex value	

3.6.6 Component: Vector_1

Comment: Complex vector (Floating Point Magnitude and Angle values)

Parent Type: Vector

Attribute	Type	Enumeration	Comment	X
mag	AnalogueValue_0		The magnitude of the complex value	
ang	AnalogueValue_0		The angle of the complex value (the unit is degrees)	

3.7 Enumerated type definitions

The following sub-sections specify the enumerations that are associated to some Common Data Class attributes. The definition of the enumerations is according to IEC61850-7-3 and IEC61850-7-4 unless otherwise stated.

3.7.1 Enumerated type: Beh

Description: Behaviour

Ordinal	Semantic
1	on
2	blocked
3	test
4	test/blocked
5	off

3.7.2 Enumerated type: Check

Description: Check –specifies the kind of checks a control object shall perform before issuing the control operation.

Ordinal	Semantic
0	No-check
1	synchrocheck
2	Interlocking-check
3	both

3.7.3 Enumerated type: ctlModel

Description: Control Model

Ordinal	Semantic
0	status-only*
1	direct-with-normal-security*
2	sbo-with-normal-security*
3	direct-with-enhanced-security (NOT SUPPORTED in Mx70 devices)
4	sbo-with-enhanced-security (NOT SUPPORTED in Mx70 devices)

* NOTE: ONLY the “Status only” and “normal security” control modes are supported in Mx70 devices

3.7.4 Enumerated type: Health

Description: Health

Ordinal	Semantic
1	Ok
2	Warning
3	Alarm

3.7.5 Enumerated type: hvRef

Description: Reference type – Specifies the reference type (i.e. ration of harmonic to fundamental, to rms, or to absolute) that the data attribute “mag” of the data attribute type “Vector” contains.

Ordinal	Semantic
0	fundamental
1	rms
2	absolute

3.7.6 Enumerated type: Mod

Description: Mode

Ordinal	Semantic
1	on
2	blocked
3	test
4	test/blocked
5	off

3.7.7 Enumerated type: orCat

Description: Originator category – specifies the category of the originator that caused a change of value.

Ordinal	Semantic	Explanation
0	not-supported	orCat is not supported
1	bay-control	Control operation issued from an operator using a client located at bay level.
2	station-control	Control operation issued form an operator using a client located at station level.
3	remote-control	Control operation from a remote operator outside the substation (for example network control center)
4	automatic-bay	Control operation issued from an automatic function at bay level.
5	automatic-station	Control operation issued from an automatic function at station level.
6	automatic-remote	Control operation issued form an automatic function outside the substation.
7	maintenance	Control operation issued from a maintenance/service tool.
8	process	Status change occurred without control action (for example external trip of a circuit breaker or failure inside the breaker

3.7.8 Enumerated type: sboClass

Description: Set before operate Class

Ordinal	Semantic
0	operate-once
1	operate-many

3.7.9 Enumerated type: seqT

Description: Sequence Measurement Type

Ordinal	Semantic
0	pos-neg-zero
1	dir-quad-zero

3.8 MMS data-type conversions

The following table shows the relationships between the Part 7 and Part 8-1 data types. The definitions presented above use Part 7 data types, however these are subject to 'translation' when exposed over an MMS (Part 8-1) interface:

Part 7 Type	MMS Type	Part 7 Description
BOOLEAN	Bool	Logical TRUE/FALSE value
BVstring13	BVstring13	Variable bit string (upto 13 bits)
CODED_ENUM	Byte	Coded enumeration
CODED_ENUM2	Byte	Coded enumeration (2)
EntryTime	Btime6	8.1 Section 8.1.3.7
ENUMERATED8	Byte	8 bit enumerated value
FLOAT32	Float	32 bit floating point value
FLOAT64	Double	64 bit floating point value
INT128	Long	128 bit signed integer value
INT16	Short	16 bit signed integer value
INT16U	Ushort	16 bit unsigned integer value
INT24U	Ulong	24 bit unsigned integer value
INT32	Long	32 bit signed integer value
INT32U	Ulong	32 bit unsigned integer value
INT8	Byte	8 bit signed integer value
INT8U	Ubyte	8 bit unsigned integer value – used in Unbuffered Report Control Blocks (URCBs)
OCTET_STRING6	Ostring6	6 character string (8 bits per character) – used in GOOSE MAC address
OCTET_STRING64	Ostring64	64 character string (8 bits per character)
OCTET_STRING8	Ostring8	8 character string (8 bits per character)
Quality	BVstring13	IEC61850 Quality
TimeStamp	Utctime	IEC61850 Time stamp
UNICODE_STRING255	UTF8Vstring255	255 character string (16 bits per unicode character)
UTC_TM	Utctime	UTC Timestamp
VISIBLE_STRING255	Vstring255	255 character string
VISIBLE_STRING64	Vstring64	64 character string
VISIBLE_STRING65	Vstring65	65 character string
VISIBLE_STRING97	Vstring97	97 character string

Section 4 TICS

Technical Issues Conformance Statement

4. IEC61850 TECHNICAL ISSUES (TISSUES) CONFORMANCE STATEMENT - TICS

4.1 Introduction

This **Technical Issues Conformance Statement (TICS)** specifies the conformance level attributed to Mx70 Series of Intelligent Electronic Devices (Mx70 IEDs) with respect to the **Technical Issues (TISSUES)** logged against the various parts of the IEC61850 standard. This document, along with the **Protocol Implementation eXtra Information for Testing document (PIXIT)**, defines the basis for conformance testing in accordance with part 10 of the IEC61850 standard specifications.

This document identifies numerous Tissues that have an impact on conformance testing of the Mx70 IED. TISSUES have been classed into the following categories:

- Tissues identified as either editorial, or related to the XML schema or a client, Tissues that are not applicable to the IEC 61850 implementation in the Mx70 devices are grouped in this class.
- Tissues identified as status "Blue" , which are considered questions only
- Tissues that have not completed or closed within the last year, or Tissues that have a status other than Green. These Tissues may or may not be listed in the conformance tables, their numbers are included for completeness, and for tracking Tissues requiring future consideration.
- Technical issues with applicability under the IEC 61850 implementation in the Mx70 devices.

According to the UCA IUG QAP the Tissue conformance statement is required to perform a conformance test and is referenced on the certificate

For more details on the logged Technical Issues, refer to the website:

<http://www.tissues.iec61850.com>

4.2 Tissues considered

This document incorporates Tissues closed prior to April-2007. Tissues that have closed within the last year are not necessarily considered for the Edition 1 implementation of the IEC 61850 standard.

4.3 Document structure

This document is broken down into several sub-sections; one per part of the IEC61850 standard specifications.

Each subsection contains

- a list of tissue numbers that relate only to editorial or schema changes,
- a list of tissue numbers that are questions only (status = Blue)
- a table of the remaining tissues that provides, for each tissue:
 - The TISSUE number
 - A reference into the appropriate section, paragraph, annexe etc.
 - The subject of the TISSUE
 - The TISSUE status (Red/Green/Yellow etc)
 - The required conformance
 - Indication if the TISSUE is supported

The required conformance column provides the following information:

Value	Meaning
Mx.y	TISSUE is included in the UCA Device conformance test procedures version x.y and is stated as mandatory.
O	TISSUE is not yet included in the UCA Device conformance test procedures, or it's a recommendation, or it's optional in the IEC 61850 documents.
tbd	To be defined. The proposal is not defined in such detail to be implemented or tested.
-	Not applicable, no change for implementation and testing.
?	Conformance is not known or unclear for the TISSUE.

The supported column provides the following information:

Value	Meaning
✓	The TISSUE is implemented in the Mx70 IED.
✗	The TISSUE has not been implemented in the Mx70 IED.
N/A	The TISSUE is not applicable to the Mx70 IED.
?	Support is not known or unclear for the TISSUE.

Note: All Tissues whose status is other than Green will indicate a conformance status of '?' and a supported status of '?'.

4.4 Document Information (TICS)

Revision History

Revision	Date	Note
A	24-June-2008	Initial Document prepared. Tissues are included up to May 2008.

Firmware Applicability

This manual is applicable to IEC 61850 for M57x/M87x firmware version v3.00.0.

4.5 Part 5 Standard

4.5.1 Specification scope

The scope of part 5 of the IEC61850 standards covers the communication requirements for functions and device models.

4.5.2 Editorial and schema related TISSUES

At the time of writing there are no logged editorial and schema related technical issues against part 5.

4.5.3 Question only Tissues

At the time of writing there are no *question only* technical issues against part 5.

4.5.4 Technical Issues

At the time of writing there are no logged technical issues against part 5.

4.6 Part 6 Standard

4.6.1 Specification scope

The scope of part 6 of the IEC61850 standards covers the configuration description language for communication in electrical substations related to IEDs.

4.6.2 Editorial and schema related TISSUES

The following technical issues are editorial and schema related only:

4,12,14,16, 157,176,197,201,211,212,245, 273,284,285,286,291,303

The following technical issues are considered not relevant for IEC61850 implementation on Mx70 devices and so they are classified as Not Applicable (N/A):

13,15,24,170,313,317,355,356,366,378,425,428,460,465,532,533,534

4.6.3 Question only Tissues

The following technical issues are questions only and no compliance is required:

2,19,20,21,22,23,158,203,210,277,280,296,318,341,353,354,357,367,371,436,445,452,454, 458,471,472, 484,491,589

4.6.4 Technical Issues

Num	Doc. Ref.	Subject	Status	Comment	Conformance	Supported
1	Annex A5	Syntax	Green	Correction to IP Address syntax to include missing “\” character.		✓
3	Annex B	Missing ENUMs	Green	Appendix: the ENUMs of stVal/ctlVal are defined, but the ENUMs are missing for: - AutoRecSt - FitLoop - PmpCtl. The Mx70 data model/ICD file does not use all defined enumerations. ENUMs AutoRecSt, FitLoop, PmpCtl, which were added, are not applicable.	M1.1	N/A
5	Annex A	tExtensionAttributeNameEnum is restricted	Green	Schema and editorial issue for Attribute names that may impact ICD and SCD validation against the SCL schema.	tbd	?

Num	Doc. Ref.	Subject	Status	Comment	Conformance	Supported
				Addressable as a document revision to part 8-1 of the standard.		
6	SCL schema	ReportControl/OptFields	Green	The "segmentation" attribute in the* ReportControl/OptFields* section of SCL should be deleted. There is no OptField within RCB, only used in reports dynamically. The Segmentation bit is ignored in the Mx70 IEDs.	tbd	✓
7	SCL schema	Duplication of attributes	Green	Setting Groups Schema The unique key in SCL schema is the name without FC, therefore it is not possible to specify the same attribute with different FCs. This is also not needed: the only attribute with two FCs are setting parameters (FC=SG, SE), where each specification with SG implicitly means an SE on MMS level, if editing is supported at all.	O	N/A
8	Annex B	SIUnit enumeration for W	Green	Use name Watts for code 62 instead of W. SIUnit is not used in Mx70.IEDs	O	N/A
9	Annex A	Data Set reference in CBs	Green	For ICD files change XML schema to allow control blocks (CBs) without a dataset reference. CBs without datasets are deactivated.	O	✓
10	Annex A	Base type for bitstring usage	Green	Part 8-1 introduces the attribute "Check" as a bitstring, however SCL does not support bitstrings. The philosophy is to have a separate base type for each kind of bitstring usage,so bType Check is added	-	N/A

Num	Doc. Ref.	Subject	Status	Comment	Conformance	Supported
				to the schema, to be used for the Check attribute. The Check attribute is not used in the Mx70 data model		
11	SCL schema	Schema for IP Addr?	Green	-	0	N/A
17	Schema	DAI/SDI elements syntax	Green	SIUnit is not used	-	N/A
18	9.3.4, Table 14	Functional naming and LDevice	Green	Mx70 uses old method, which is to always use "IEDName + inst." "inst" is the attribute name identifying the LDevice within the IED. The full LD name contains an additional part before the "inst" value.	?	N/A
130	General	LDName length	Green	LDName is not used in Mx70 IEDs. Issue is supported by the S1 IED Configurator, IdName = iedName+IdInst	M1.1	✓
169	p. 119, Appendix B	Ordering of enum differs from 7-3	Green	"Angld" enumeration is not used in Mx70 data models	-	N/A
186	Table 21	Definition of DataSet Members	Green	Datasets are not allowed to contain Control Blocks. The proposed solution is that a data set might contain FCDA elements as reference to the data model, and FCCB elements as reference to the control blocks. This allows the highest level of checking on XML schema level the correctness of the object references . This is a change to SCL but does not presently have an impact to Mx70 devices. (Note that more intelligence would be	M1.1	N/A

Num	Doc. Ref.	Subject	Status	Comment	Conformance	Supported
				need to be incorporated into Areva's S1 MiCOM IED for this to become a configuration issue)		
233	-	9-2 Security Attribute	Green	The attributes "security" and "noASDU" are mapping specific and defined in 9-2. Add the security attribute to the SCL. Mx70 does not support part 9-2 of the standard.	?	N/A
243	p. 65, 9.3.8	RCB Naming	Green	Resolved by always using the default "index" naming. Report Control Blocks (RCBs). URCB01-URCB08 are the unbuffered control blocks used.	-	x
272	p. 23, 8.2.6	Private section type	Green	Make the use of the "type" attribute of the "Private" element as 'required' instead of 'optional'. The "type" attribute is always used. (Note: MiCOM S1 IED configuration issue, such that IED configurator always uses type.)	?	✓
302	P 58, 9.3.7 Attributes of the FCDA element	References for arrays in DataSets	Green	Although the Mx70 does support harmonic array elements in its data model. Data set members cannot contain individual array elements.	-	N/A
307	9.3.2	Flag buffered/unbuffered reporting in element service	Green	Can't implement this yet. It is an Issue for Edition 2 to address that involves the tree structure defined in the Schema. It is not possible to resolve under Edition 1 of the IEC 61850	?	?

Num	Doc. Ref.	Subject	Status	Comment	Conformance	Supported
315		Number of client associations	Green	implementation. Proposal entails adding an element to the service section of the IED section that holds the maximal number of supported client associations Can't implement this yet, since this service isn't supported under Edition 1 of the IEC 61850 implementation Note: MiCOM ICD file will also need to supports this.	?	?
529	p. 118, Annex B (normative)	Sev	Green	The first EnumVAI for <Enumtype id="sev"> is not Unknown but unknown. Proposal is to replace Unknown by unknown. "Sev" is not used by Mx70 devices.		N/A

4.7 Part 7-1 Standard

4.7.1 Specification scope

The scope of part 7-1 of the IEC61850 standards covers the architecture for communication and interactions between substation devices such as protection devices, breakers, transformers, substation hosts etc.

4.7.2 Editorial and schema related TISSUES

The following technical issues are editorial and schema related only:

174, 267.

4.7.3 Question only Tissues

The following technical issues are questions only and no compliance is required:

450

4.7.4 Technical Issues

Num	Doc. Ref.	Subject	Status	Comment	Conformance	Supported
129	13.2.2, Table 13	Coming/Going events?	Green	Both edges trigger in order to capture signals that transition from 0 to 1 and from 1 to 0. Note that a client can filter out the signal changes or transitions that are not desired.	-	✓
250	p.75, 13.2.2	Trigger option used, if not defined	Green	TrgOps value masks triggers in event generation. If attribute is not marked for dchg or qchg, then changes will not trigger reports or logs.	tbd-	✓

4.8 Part 7-2 Standard

4.8.1 Specification scope

The scope of part 7-2 of the IEC61850 standards covers the layered substation communication architecture principles.

4.8.2 Editorial and schema related TISSUES

The following technical issues are editorial and schema related only:

29,33,137,142,149,192,195,275,308,338,339,342,351(rejected),361,369,379,
 385,387,388,390,392,393,398,399,400,404,406,408,409,410, 411,415,
 418,449,451,453,456,457,461,473,474,490.

4.8.3 Question only Tissues

The following technical issues are questions only and no compliance is required:

172,181,193,251,287,293,295,345,346,347,350,352,389,402,412,413,427,435,440,449,462,
 540,546

4.8.4 Unaddressed or open Tissues

The following Tissues were not considered in the present implementation of IEC 61850 Edition 1 in the Mx70 devices:

310,403,407,416,429,447,492,493,494,495,496,497,498,499,500,501,502,503,505,506,507,
 508,509,510,512,513,514,515,516,517,518,520,521,522,523,524,526,536,537,
 549,580,593,595,610.

4.8.5 Technical Issues

Num	Doc. Ref.	Subject	Status	Comment	Conformance	Supported
30	17.5.2.3	Control parameter T	Green	Change sentence to “The parameter T shall be the time when the client sends the control requests” (plural for request indicating there may be several requests). There are some further clarifications regarding the T parameter required as follows: - The T-parameter shall not be modified by the server - it will be mirrored with the response - the client may use it, to associate a response with the request - any other uses of T are local issues and outside the scope of the standard		✓

Num	Doc. Ref.	Subject	Status	Comment	Conformance	Supported
31	14.2.3.2.3.2	Typo	Green	Change the last sentence in the clause from “on a quality-change” to “On a data-update”. DuPd is not used		N/A
32	14.2.2.1 14.4.2.1	Typo in syntax	Green	BRCB class Syntax, (page 77) URCB class Syntax, (page 94) The attribute “TrgOp” shall be plural as “TrgOps”		✓
34	15.1	Publish.request explanation	Green	Ed2: The Mx70 devices trigger GOOSE events on both data transitions.	M1.1	✓
35	17.5.2.3, Table 36	Typo Syntax Control time	Green	Proposal is to Change Attribute type from “EntryTime” to “TimeStamp”.	-	✓
36	15.2.2.3, 15.2.2.4	Syntax parameter DSet-Ref missing	Green	Proposal: Add the missing text, “15.2.2.3.3.3 (15.2.2.4.3.3) DataSetReference The parameter DataSetReference shall contain the Reference of the DATA-SET whose members have been requested.” GOOSE Management is not supported in Mx70 devices.		N/A
37	15.2.3.1	Syntax GOOSE "T" type	Green	This issue involves the GOOSE message syntax The Attribute type “T” is a time handled by the application. “EntryTime” is not correct, because “EntryTime” is for “internal” use: see clause 5.5.3.8. The proposal changes Attribute type from “EntryTime” to “TimeStamp”.	M1.1	✓
38	15.2.1 15.2.1.4	Syntax "AppID" or "GoID"	Green	Ed.2: Change Attribute name from “AppID” to “GoID”.	M1.1	✓

Num	Doc. Ref.	Subject	Status	Comment	Conformance	Supported
39	15.2.1	Add DstAddr to GoCB	Green	Issue: Additional attribute in GoCB definition required. Proposal: Add Attribute "DstAddress" after the Attribute "NdsCom" "15.2.1.8 DstAddress The attribute DstAddress shall be the SCSM specific addressing information like media access address, priority, and other information."	M1.1	✓
40	15.2.3.1 15.2.3.3	GOOSE Message AppID to GoID	Green	Issue: GOOSE message syntax (page 116) AppID – application identifier (page 116) The Attribute name "AppID" is misleading and too general. IEC 61850-8-1 uses "GoID" instead Proposal: Change Attribute name from "AppID" to "GoID".	M1.1	✓
41	15.3.1 15.3.4.1	GsCB AppID to GsID	Green	Issue: GsCB class definition (page 118) Syntax (page 125) The Attribute name "AppID" is misleading and too general. IEC 61850-8-1 uses "GsID" instead Proposal: Change Attribute name from "AppID" to "GsID". (Note: GsCB is not supported for Mx70 devices, although GsCB messages are supported via the 70 Series Configurator.)	-	N/A
42	p.138, 16.4	SV timestamp: EntryTime to TimeStamp	Green	Mx70 devices do not support Sampled Values	-	N/A
43	p.148, 17.5.2.3	Control "T" semantic	Green	"The parameter T shall be the time when the client sends the control requests. Add NOTE: "Control requests can be Select, Operate, or Cancel."	-	✓

Num	Doc. Ref.	Subject	Status	Comment	Conformance	Supported
44	17	AddCause - Object not sel	Green	ACSI AddCause values. Under part 8-1 has defined a new value as "Object-not-selected 18". AddCause is used only for Enhanced-Security Control. Mx70 devices use only Normal-Security Controls.	-	N/A
45*	17.5.2.6	Missing AddCauses	Red	Add additional cause types?	?	?
46	17.3.3	Synchro check cancel	Green	Synchro-check is ignored by Controls.	?	N/A
47	19.2, Figure 40	"." in LD Name?	Green	The LDName is limited to 64 characters. '.' or '\$' or other '=' are not allowed. The IEC61850-7-2 standard will be corrected correspondingly.	-	✓
48	17.2.1, Figure 30	Syntax in state machine	Green	Time activated controls are not supported		N/A

Num	Doc. Ref.	Subject	Status	Comment	Conformance	Supported
49	14.2.2.16	BRCB TimeOfEntry	Green	<p>"The report handler assigns EntryID(s) and TimeOfEntry(s) to the values contained within a set of notifications. The number of notifications combined into a single EntryID is determined by the RCB control parameters (e.g. BufTim). The value of the EntryID is a local issue but it shall be a unique arbitrary OCTETSTRING whose value is unique within the scope of entries for a specific RCB. The value of the TimeOfEntry shall be the timestamp representing the time at which the report handler received the first notification that is used to form an EntryID."</p> <p>Within the GetBRCBValues : "The value, returned in a GetBRCBValues response, shall provide the time stamp of the EntryID whose value is exposed in the control block. The value exposed for TimeOfEntry, when the value of EntryID is zero(0), is a local issue."</p> <p>Therefore, after having set the BRCB state in resync, the client is able to check if the EntryID that is set, is the one that knows, since the couple "EntryID, TimeOfEntry" will always be unique during the whole lifetime of an IED (and of its replace part if a replacement should occur)</p>	?	✓
50	19.2	LNName start with number	Green	<p>The LNName prefix shall start with a letter. Otherwise, mapping to MMS should restrict it, since MMS variable names are not allowed to start with a number.</p>	-	✓

Num	Doc. Ref.	Subject	Status	Comment	Conformance	Supported
51	5.5.2	ARRAY [0..num] missing		<p>Text to be included in draft Ed2:</p> <p>The type ARRAY shall be as defined as follows: ARRAY [n..m] OF p with n = 0 or n = 1; m > 0; p = Common data attribute type or BasicType or Common ACSI type shall represent a list of elements numbered from "n" to "m". The type of the elements shall be as specified by "p".</p> <p>The ARRAY type shall be applied for DataAttributes only.</p> <p>NOTE Common data attribute types for substation automation applications are defined in IEC</p> <p>This text is posted under Tissue 456.</p> <p>The impact of the new type ARRAY on the services GetData... and others has to be analyzed. Will be resolved with clause 10 tissues.</p>	-	✓

Num	Doc. Ref.	Subject	Status	Comment	Conformance	Supported
52	15.2.3.6	Ambiguity GOOSE SqNum	Green	<p>Issue: There is a discrepancy between the 7-2 and 8-1 definitions of GOOSE SqNum.</p> <p>7-2 clause 15.2.3.6 states: 'The initial value for SqNum shall be 1. The value of 0 shall be reserved.'</p> <p>Whereas 8-1 clause 18.1.2.15 states: 'The value of 0 is reserved for the first transmission of a StNum change.'</p> <p>Proposal: Change part 7-2 to match 8-1.</p> <p>The SqNum shall be set to 0 to indicate the first GOOSE transmission initiated by a value (increment of StNum) change.</p> <p>The first GOOSE message after a state change should be easily distinguishable from all other messages.</p> <p>The revised Text is: "Following a StNum change, the counter SqNum shall be set to a value of 0. If the counter SqNum overruns, it shall be set to a value of 1. The initial value for SqNum upon a transition of GoEna to TRUE shall be 1."</p>	-	✓

Num	Doc. Ref.	Subject	Status	Comment	Conformance	Supported
53	15.3.1, 16.2.1, Table 30,32	Add DstAddr to GsCB, SV	Green	<p>Within the current scheme of 61850, the GSE and SMV control blocks do not contain the destination (multicast) MAC address, while the Goose control blocks do. This means that the only way of finding out the group addresses for GSE and SMV are through SCL. This is fine if everything is configured correctly, but does not allow for the validation of the configuration, and will make diagnostics needlessly difficult. If we made the addresses visible in MMS, life will be much simpler for utilities. Proposal: Add the group addresses for GSE and SMV.</p> <p>Neither GsCB nor SMV are used in Mx70 devices.</p>	-	N/A
150	p.58 11.2.2.3	Attributes of Control Blocks as members of DataSets	Green	Ed2: Unsupported in Mx70 devices	?	N/A

Num	Doc. Ref.	Subject	Status	Comment	Conformance	Supported
151	p.156-157, 19.2	Name constraint for control blocks etc.	Green	<p>Issue: The instance names for the following classes need to be constraint in clause 19.2:</p> <ul style="list-style-type: none"> - DataSet - all Controlblocks <p>The instance names are concatenated with LNNames. The "LNName.xxName" must fit into 32 (according to 8-1 64) characters.</p> <p>See also comment #141 and IEC 61850-8-1 clause 17.1.1.1 (-2) Note below table 37 (39).</p> <p>Proposal: Define the (common) rule for building instance names for DataSet and control blocks. In clause 19.2, the explanation of FCD shall be changed from "29 characters..." to "61 characters..."</p>	-	✓
163	10.2.2.4.3	TISSUE 63 from 7-3	Green	Deadbands are not supported	-	N/A
166	14.3.3.2.7.3	DataRef attribute in Log	Green	<p>The parameter DataRef shall contain the DataSet member reference of the value of the EntryData. The parameter value shall contain the DataSet member values to be included in the EntryData.</p> <p>Logging is not supported by Mx70.</p>	-	N/A
180	12 Figure 16	Figure substitution misleading	Green	Subst is not supported	-	N/A
185	14.3.3.2.7.3	Logging - Integrity period	Green	Logging is not supported by Mx70	-	N/A

Num	Doc. Ref.	Subject	Status	Comment	Conformance	Supported
187	16	OptFids in SV CB's not exposed for client specification	Green	ED 2: Include the OptFids MSVCB and USVCB in the control block get and set services, however, this is only true for SV Control Blocks (CB); in GOOSE CB we do not have OptFids. SV is not supported by Mx70 devices	Tbd	N/A
188	p.138, 16.4, Table 34	SV Format	Green	Ed2: SV not supported in Mx70 devices	-	N/A
189	p. 134, 16.4, Table 34	SV Format	Green	SV not supported in Mx70 devices	-	N/A

Num	Doc. Ref.	Subject	Status	Comment	Conformance	Supported
190	p.77, 14.2.2.1	BRCB: EntryId and TimeOfEntry	Green	<p>See Tissue 49 for definition of TimeOfEntry and interaction with EntryID, and uniqueness within the system. see Tissue 453 for chapter edition including the BRCB state machine.</p> <p>EntryID in GetBRCBValues: "The value of EntryID, returned in a GetBRCBValues response shall be defined as follows: • When the BRCB state is disabled: a GetBRCBValues shall return the EntryID value that represents the last (i.e..newest) entry that has been entered into the buffer. • When the BRCB state is resync: a GetBRCBValues shall return the value of the EntryID specified within the last SetBRCBValues. • When the BRCB state is enabled: The value of EntryID, returned in a GetBRCBValues response, shall be the EntryID of the last set of events sent. An EntryID value of all zeros(0) is reserved to indicate an empty buffer, no reported EntryID shall have a value of zero(0). "</p> <p>TimeOfEntry in GetBRCBValues: "The value, returned in a GetBRCBValues response, shall provide the time stamp of the EntryID whose value is exposed in the control block. The value exposed for TimeOfEntry, when the value of EntryID is zero(0), is a local issue."</p>	?	✓

Num	Doc. Ref.	Subject	Status	Comment	Conformance	Supported
191	p.78/81, 14.2.2.5 14.2.2.12	BRCB: Integrity and buffering reports	Green	<p>see Tissue 453 for the revised chapter, inc. the GI state machine.</p> <p>GI are not buffered except the last one, till the next GI request is received, then the previous GI is removed from the Buffer. Buffering the Last GI has been decided to avoid BufOflv and therefore transmission of the whole history.</p> <p>Integrity reports are buffered, but a note has been added regarding to the memory limitation.</p> <p>"The BRCB shall buffer entries based on the trigger options data-change, quality-change, data-update, and integrity during loss of association. After the association is available again, after the client has set the EntryID, and enabled the BRCB, the BRCB shall start sending the reports of events that have been buffered. The BRCB shall use the sequence and subsequence numbers so that no gaps occur. NOTE Since the buffer events based on the trigger option integrity are buffered by the BRCB, and the memory of the IED dedicated for the buffering is limited, it is recommended to use the trigger option integrity in the BRCB with great care, to avoid a BufOvfl, and keep a long historical of the events."</p>	?	✓

Num	Doc. Ref.	Subject	Status	Comment	Conformance	Supported
220	p.48, 10.2.2.4.2, Table 18	FC SP	Green	<p>Issue: Referring to TISSUE 28 of 7-3, the definition of SP in Table 18 is not correct anymore (and it was never completely correct anyway).</p> <p>SP is now only used for setting parameters, and not for setpoints anymore. SP attributes can be changed using the SetDataValue service (see 7.7.1 of IEC 61850-7-3, Ed1).</p> <p>Proposal: Change Text in Table 18 as follows: "DataAttribute shall represent a setting parameter information whose value may be written and read. Changes of values shall become effective immediatly"</p>		✓
234	p.21, 5.5.2	New type CtxInt	Green	As a consequence of TISSUE 146 (General) and TISSUE 120 (8-1), a new basic type CtxInt is added.	?	✓
236	19.2	Name length	Green	Ed2: LD name length up to 64 LN Name + rest length up to 64	?	✓
261	19	IEDName starts with number?	Red	Ed2:	?	?

Num	Doc. Ref.	Subject	Status	Comment	Conformance	Supported
278	p.82, 14.2.2.15	EntryId not valid for a server	Green	<p>The state resync has been added. The BRCB is and remains in state resync while it is not enabled and the client set EntryIDs of entries that are available in the buffer of entries.</p> <p>If no entry is found in the buffer of entries corresponding to the value of the EntryID set by the Client in the SetBRCBValues, then the state of the BRCB goes to disable.</p> <p>Use of EntryID within the BRCB :</p> <p>The reported entries are dependant upon the transitions of state of the BRCB and are handled as follows:</p> <ul style="list-style-type: none"> • A transition from disabled to enabled shall start reporting with the first available entry (i.e. oldest) in the queue of entries. Reporting of the next sequential entries shall occur. • A transition from resync to enabled shall start reporting with the next available entry (i.e. in time sequence), in the queue of entries, after the entry associated with the EntryID value set by the client. Reporting of the next sequential entries shall occur. <p>The value of EntryID, returned in a GetBRCBValues response shall be defined as follows:</p> <ul style="list-style-type: none"> • When the BRCB state is disabled: a GetBRCBValues shall return the EntryID value that represents the last (i.e..newest) entry that has been entered into the buffer. <p>(continued)</p>	?	✓

Num	Doc. Ref.	Subject	Status	Comment	Conformance	Supported
		(278 continued from previous page)		<ul style="list-style-type: none"> • When the BRCB state is resync: a GetBRCBValues shall return the value of the EntryID specified within the last SetBRCBValues. • When the BRCB state is enabled: The value of EntryID, returned in a GetBRCBValues response, shall be the EntryID of the last set of events sent. An EntryID value of all zeros(0) is reserved to indicate an empty buffer, no reported EntryID shall have a value of zero(0). 		
289	10 and 19	Instatiation of DATA	Green	Ed2: LNName consists of LN-Prefix, LN class name and LN-Instance-ID. To be consistent, it should be defined that DataName =Data class name [Data-Instance-ID] Data class name = up to 10 characters Data-Instance-ID = n numeric characters, optional; n shall be equal for all instances of the same data	?	✓
297	14.2.2.10	Sequence number	Green	Definition of SqNum : "The BRCB that has report enable set to TRUE shall maintain the parameter SqNum. This number shall be incremented by the BRCB for each report generated and sent on the basis of the BRCB. The increment shall occur once the BRCB has formatted the report for transmission. The first report following the setting of the report enable to TRUE shall contain sequence number 0. The sequence number shall roll over to 0 at its maximal value."	?	✓

Num	Doc. Ref.	Subject	Status	Comment	Conformance	Supported
298	Table 23 & 25	Type of SqNum	Green	Attribute size for SqNum remains INT16U for Buffered Report Control Blocks (BRCB) and INT8U for Unbuffered Report Control Blocks (URCB)	?	✓
300	p.77 14.2.2.1 Table 23	Attribute Resv in BRCB	Green	Creation of ResvTms-Reservation Time- as optional new attribute added to Buffered Report Control Block (BRCB). New Attribute ResvTms is optional. But this is unchanged from the IEC 61850 standard	?	✗
305	p. 80, p.85, 14.2.2.9, 14.2.3.2.2.9	Reporting with BufTm=0	Green	If more then one member of a data set changes at the same time then multiple reports are sent. In general each data change causes a new Goose/Report..	?	✓
322	14.2.2.1 & 14.2.4.1	Write Configuration attribute of BRCBs	Green	Modification of a configuration in side the report control block is not allowed in Mx70 devices. Therefore the Write configuration attributes are not applicable for Mx70 implementation.	?	N/A
325	p.24, 5.5.3.7.2 Table 7	TimeStamp definition	Green	Ed2: Correct the Attribute type from INT32 to INT32U in order to extend time reach from 2038 to 2106. Seconds is unsigned INT32	-	✓

Num	Doc. Ref.	Subject	Status	Comment	Conformance	Supported
329	P.85, 14.2.3.2.2.8 Para 1	Reporting and BufOvl	Green	BRCB is supported in Mx70 devices. BufOvfl shall indicate to the client that entries within the buffer may have been lost.. The detection of possible loss of information occurs when a client requests a resync to a non-existent entry or to the first entry in the queue. If one of the Entrys discarded causes the Report Handler to move the pointer to the Next Entry for transimission, the implementation shall indicated BufOvfl=TRUE in the next entry that is formatted and transmitted only. In other words, the buffer-overflow bit should only be True if the Resync EntryID is not found in the buffer and buffered information has been discarded prior to resync/enabling of reporting. See Tissue 453	-	✓
331	p.143, 17.2.2 Para. d)	SBO Control Normal Security	Green	Ed2: This is a specification issue, such that. "the control object shall turn to the state Ready if sboClass = OPERATE_MANY, or Unselected if sboClass = OPERATE_ONCE"	-	✓
332	p.88, 14.2.3.2.3.2	Ambiguity in use of trigger options	Green	Data attributes with empty trigger options will not trigger any reports other than those due to GI & integrity poll.	-	✓
333	p.110, 15.2.1.3	Enabling of an incomplete GoCB	Green	The revised text is: "If there are inconsistent attribute values in the GoCB (e.g. the value of DatSet is Null) or if the value of ConfRev equals 0, a SetGoCBValues with the parameter GoEna equals TRUE shall fail and a negative response shall be issued."	-	✓

Num	Doc. Ref.	Subject	Status	Comment	Conformance	Supported
334	p.142, 17.3.3	Select a SBO object twice	Green	<p>Ed2: Reseting the SBO Timeout timer may lead to security issues. the purpose of the SBO Timeout was to introduce an autamtic un-selection to avoid that a control object remains un-available for a long time after a selection. The proper AddCause depends on the state of the state machine associated to the control object.</p> <p>If the second select occurs before the operate request, then the AddCause shall be Already-selected.</p> <p>If the second select occurs after the operate request, then the Addcause shall be command-already-in-execution</p> <p>In both cases, regardless if same or another client.</p> <p>Extend the Select timeout period for SBO. The tissue refers to SBO ES which we don't do. Under SBO ES you indicate reason to fail the operation. Under SBO the timeout is supported by extending the timeout (This is really a PIXIT issue)</p> <p>This TISSUE has had many contradictory possible resolutions. The Mx70 performs a "extend timeout" upon a second select from the same client.</p>	-	✓
335	p. 85, 14.2.3.2.2.8	Clearing of Bufovfl	Green	<p>Buffer Report Control Blocks are implemented in the Mx70 Series.</p> <p>The specification should add the following sentence. The BRCB shall clear the BufOvl flag after the BRCB is able to buffer new unreported events, which generally occurs immediately after the BRCB sends a report.</p>	-	✓

Num	Doc. Ref.	Subject	Status	Comment	Conformance	Supported
337	p.164, Annex A, Table A.2, M7 and M8	Configuration Revision option missing	Green	Ed2: Add the options missing in the "ASCI models conformance statement as follows: M7-11 : conf-revision M8-9 : conf-revision The Protocol Implementation Conformance Statement (PICS) is updated to include configuration revision		✓
348	p.92, 93, 14.2.4, Para 14.2.5.2	URCB class and report	Green	Allow TimeOfEntry (report time stamp) of URBC reports to exist independent of missing EntryID.		✓
349	p.75, Para. 14.2.2.16, 14.2.3.2.2.9	BRCB TimeOfEntry has two definitions	Green	see Tissue 49 for definition of TimeOfEntry and interaction with EntryID, and uniqueness within the system. see Tissue 453 for chapter edition incl. the BRCB state machine. EntryID in GetBRCBValues: "The value of EntryID, returned in a GetBRCBValues response shall be defined as follows: • When the BRCB state is disabled: a GetBRCBValues shall return the EntryID value that represents the last (i.e..newest) entry that has been entered into the buffer. • When the BRCB state is resync: a GetBRCBValues shall return the value of the EntryID specified within the last SetBRCBValues. • When the BRCB state is enabled: The value of EntryID, returned in a GetBRCBValues response, shall be the EntryID of the last set of events sent. (continued)		✓

Num	Doc. Ref.	Subject	Status	Comment	Conformance	Supported
		(349 continued from previous page)		<p>An EntryID value of all zeros(0) is reserved to indicate an empty buffer, no reported EntryID shall have a value of zero(0).</p> <p>TimeOfEntry in GetBRCBValues: "The value, returned in a GetBRCBValues response, shall provide the time stamp of the EntryID whose value is exposed in the control block. The value exposed for TimeOfEntry, when the value of EntryID is zero(0), is a local issue."</p> <p>Note: BRCB is not used by Mx70</p>		
370	p.146,147 17.4 Procedure b)	Time-activated operate and further conditions like mode	Final proposal	<p>Ed2: Add the conditions that have to be met before the action can be activated:</p> <p>"b) On expiration of the timer the wanted action shall be activated (if the conditions LNBeh = on or test AND LDMode = on or test AND Loc of LN = false AND Loc of LLN0 = false) and a response shall be sent to the client."</p> <p>In general: the State Machines for control should reflect these conditions as well ... may be it would be sufficient to state this at the beginning of clause 17 (Control). These conditions have to be met in any case.</p> <p>Note: The Mx70 does not support time activated operate</p>	-	N/A

Num	Doc. Ref.	Subject	Status	Comment	Conformance	Supported
373	p.64, clause 12	Substitution subVal and subID	Green	<p>Ed2: To keep track which client issued the last set it is required to set the subID anytime when a new value is set for: subVal, subMag, subCMag, and subQ.</p> <p>This may be implemented in an SCSM by a set service that carries two values: one for subXxx and one for subID.</p> <p>With reporting and logging one could track the sequence of changes.</p> <p>If we want to prevent a second client to change any substitution values (in state subEna=True), then we would need a semaphore for substitution (or a similar mechanism).</p> <p>Note: The Mx70 does not support substitution.</p>	-	N/A
374	p.64, clause 12	Over-write substitution values	Green	<p>Ed2: After subEna is set to True it shall be possible to set new values (over-write the current values) for subVal, subMag, subCMag, subQ, and subID. The updated values shall be used to update the corresponding process values (stVal, ...).</p> <p>The over-write of the values subVal, subMag, subCMag, and subQ shall be accompanied by a new value for subID. (Note: The Mx70 does not support substitution.)</p>	-	N/A
384	p.18, 5.3, Figure 3	Conceptual service model in 5.3	Green	Log is not used	-	N/A
386	p.54, 10.4.2.3	GetDataValues - leafs not access	Green	The attempt to set a DataAttribute or an underlying component that is not available shall be interpreted as a service failure.	-	✓

Num	Doc. Ref.	Subject	Status	Comment	Conformance	Supported
391	p.21, 5.5.2, Table 2	Basic Types (STRING)	Green	Full name is 129 octets	-	✓
405	p.160 & 161 20.2.2	SetFile	Green	SetFile is not supported	-	N/A
417	p.120, 15.3.3.1	GSSE service definitions	Green	GSSE is not supported	-	N/A
426	p.58, 11.2.1	Dataset contents configurability	Green	<p>Ed2: The following text has been added: An IED which claims to support dynamic creation of datasets (CreateDataSet) shall be able to receive (as a server), send (as a client), and process (as a server or as a client) any valid FCD or FCDA definition contained in the CreateDataSet request. An IED which claims to support configuration of datasets (via SCL) shall be able to process (as a server or as a client) any valid FCD or FCDA definition contained in the corresponding SCL file.</p> <p>Note: Unknown whether the Areva MiCOM configurator will support this configurability</p>	-	✓
455	Clause 17	Canceling a started control sequence	Green	<p>Ed.2: Canceling a started control sequence shall be possible.</p> <p>The Edition 1 (Ed.1) does limit the use of cancel for too few cases.</p> <p>It should also be clarified when a cancel can be successfully performed by another client than the one that started the control sequence.</p> <p>Clarify in Edition 2.</p>	-	✓

4.9 Part 7-3 Standard

4.9.1 Specification scope

The scope of part 7-3 of the IEC61850 standards covers the abstract common data class definitions.

4.9.2 Editorial and schema related TISSUES

The following technical issues are editorial or schema related only:

56,57,58,59, 61,62,64,138,161,182,213,266,340,358,359,414,424,483

4.9.3 Question only Tissues

The following technical issues are questions only and no compliance is required:

66,,67,214,223,274,312,437,489,530,531,542,581

4.9.4 Technical Issues

Num	Doc. Ref.	Subject	Status	Comment	Conformance	Supported
28	7.6.2	Definition of APC	Green	The APC Common data class (CDC) is not used within the Mx70 data model.	O	N/A
54	6.11	Point def xVal, not cVal	Green	"Point " is not used	?	N/A
55	7.4.5 Table 25	Ineut = Ires ?	Green	Resolution matches measurements for Mx70 devices Four currents are available for direct measurement using CTs (A,B,C, neutral). Some systems only measure 3 and estimate the "neutral" using instantaneous summations of the phase currents. An additional computed measurement is the residual which is computed in exactly the same fashion as the neutral estimate. (continued)	?	✓

Num	Doc. Ref.	Subject	Status	Comment	Conformance	Supported
		(55 continued form previous page)		<p>The key difference is that some systems need the residual value even when there already is a direct measurement of the neutral current. In fact, the difference between the neutral current and the residual current represents the "leakage" current (current passing through paths outside of the measurement paths).</p> <p>When only 3 measurement CTs exist the neutral and residual should produce identical results, but we still should allow systems with direct neutral measurements.</p> <p>Explanation added in table 48 clause 8</p> <p>1) neut (WYE): modified explanation: "Value of the measured phase neutral. If a direct measurement of this value is not available, it is acceptable to substitute an estimate computed by creating the algebraic sum of the instantaneous values of currents flowing through all live conductors. In that case, 'neut' is identical to 'res'. For further details see phsA (WYE)."</p> <p>(2) res: add the text "For further details see phsA (WYE)"</p> <p>(3) net: add the text "For further details see phsA (WYE)"</p>		

Num	Doc. Ref.	Subject	Status	Comment	Conformance	Supported
60	Table 13/21 and other	Services missing in tables	Green	Document issue is resolved by defining the list of services supported by the data attributes: for GSE models (SendGOOSEMessage , ...)	?	N/A
63	General	mag in CDC CMV	Green	Add the following notes: - that the instCVal.mag (the mag component of Vector) is NOT a deadbanded value. - that the deadband calculation for cVal.mag and cVal.ang is based on instCVal.mag and instCVal.ang - Data attribute mag is not the same as data attribute component of the data attribute type vector.	?	✓
65	General	Deadband calculation of a Vector and trigger option	Green	Deadbands are not supported.	?	N/A
68	General	New CDC ACI	Green	The Common Data class ACI is unused in Mx70 devices.	O	N/A
164	6.5	Deadband on range limits	Green	"Range" is not used	?	N/A
171	p.24,p.40 p.46	Enums from 7-4	Green	The issue was already addressed and solved as Part of Tissues 120/146.	?	✓
204	7.7 and 7.8	Reporting of setting values	Green	Mx70 doesn't do reporting of control settings	?	✗
205	p.42 7.9.2 table 46	Device name plate - missing description "d" and "dU"	Green	Attributes "d" and "dU" are always optional. Mx70 utilizes "d" description but not "dU"	O	✗
217		CDC for LN Inputs	Green	Mx70 data models do not use the ORG Common Data Class (CDC)	?	N/A
219	7.3.5 Table 17	operTm in ACT	Green	ACT is not used in the Mx70 data model	?	N/A

Num	Doc. Ref.	Subject	Status	Comment	Conformance	Supported
239	p.22, clause 7.2, Table 12	Conflict of LPL definitions with requirements of Namespace	Green	Logical device Namespace, LdNs, is in LLN0.LPL	?	✓
240	p.61, Table A.4	New type of SI unit	Green	PFRC is not used in Mx70	Tbd	N/A
247	p.60-62, Table A	Miss % representation	Green	"Unit" is not used in Mx70.	?	N/A
265	6.2.1	Quality extension	Red	"Unit" is not used in Mx70.	?	?
266	p.28, and more, 7.4.2 and more, Table 22 and more	Open Enumeration of range	Green	Range is not used in Mx70.	?	N/A
270	p.31, clauses 7.4.5, 7.4.6	WYE and DEL rms values	Green	Interpretation of magnitude (rms or phasors): If there is an angle present, the values are phasor values and attribute mag represents the maximum value of the sinusoidal wave form. If there is no angle present, the attribute mag represents an rms value. Default of Rms is used. in Mx70.	?	✓
327	p.61, Table A.4	More new types of unit	Green	New unit types "Number of characters" and "Baud" are not applicable	?	N/A
328	p.61, Table A.4	New unit for frequency functions	Green	New unit types "Number of cycles" and "Baud" are not applicable	?	N/A
330	7.4.8 thru 7.4.10	CDC HMV, HWYE, HDEL	Green	Substitution is not supported in the Mx70 devices.	?	N/A
375	p.25, 7.3.6	Directional loop activation information	Green	Common Data Class ACD is not used.	?	N/A
439	p.47, 7.8.2 (ASG) Table 43	Lower limit of stepSize in ASG	Green	stepSize is not used	?	N/A

Num	Doc. Ref.	Subject	Status	Comment	Conformance	Supported
469	-	oper timeout missing in controlable CDC	Green	Enhanced security is not used	?	N/A
482	p.29, 7.4.3, Table 23	Quality evaluation of a Vector	Yellow			
519	Annex A	Add new unit to table A4	Green	New unit turbine inertia is not used.	?	N/A
525	7.4.2, Table 22	subMag and instMag in CDC MV	Final proposal			
582	p.26, 7.3.8	BCR actVal as INT128	Green	This tissue has not been considered for Edition 1 implementation of IEC61850, since it is recent and I<1 year since issue.		
615	p.22, Table 12	dataNs, cdcNs, InNs definitions	Red			

4.10 Part 7-4 Standard

4.10.1 Specification scope

The scope of part 7-4 of the IEC61850 standards covers the compatible Logical Node class and data class definitions.

4.10.2 Editorial and schema related TISSUES

The following technical issues are editorial and schema related only:

69,70,71, ,77,78, ,87,88,89,100,107,108,145, 255,
 381,382,383,394,395,396,397,401,432,441,442,443,485,486,487

4.10.3 Question only Tissues

The following technical issues are questions only and no compliance is required:

81,93,103,215,221,241,248,321,444,448,464,481,538,543,544

4.10.4 Technical Issues

Num	Doc. Ref.	Subject	Status	Comment	Conformance	Supported
72	General	Single phase metering missing	Green	The Mx70 devices do not support Non phase related Metering, hence this new Logical Node MMTN is not used within the data model.	M1.1	N/A
73	5.11.3 5.11.4	Instances of LN SIMG (SIML)	Green	Logical Node SIMG (SIML) on insulation medium supervision is not used in Mx70 devices;.	Tbd	N/A
74	Clause 6	PresTr	Green	The Data Object named Insulation Liquid pressure trip (PresTr) and Logical Node Insulation medium supervision (liquid) are not used. in Mx70 devices		N/A
75	5.7.1	Str and Op	Green	Str and Op are already optional in the GAPC logical node, however Mx70 devices do not use this logical node within the data model.	Tbd	N/A
76	Clause 6	CBOpCap and SwOpCap	Green	Data Objects CBOpCap and SwOpCap are not used in the Mx70.	?	N/A
79	Clause 6, Table 9	AutoRecSt and Lockout	Green	These Data objects are not used.	?	N/A

Num	Doc. Ref.	Subject	Status	Comment	Conformance	Supported
80	5.13	TCTR and TVTR - Over	Green	Amp and Vol are removed.	?	✓
82	5.10	New LN Class, control measuring function	Green	New Logical Node class MCXL is not used in Mx70 devices.	?	N/A
83	5.6.6	Operation by CSWI.	Green	CSWI is not used	?	N/A
84	Clause 6, Table 9	Data Name "InOv"?	Green	LPHD.InOv is not used in Mx70 devices	?	N/A
85	Clause 6, Table 9	RsStat - device security statistics	Green	RsStat is not used in Mx70 devices	?	N/A
86	Clause 6, Table 9	PwrSupAlm and EEHealth	Green	Data objects are not used in Mx70 devices.	?	N/A
90	5.6.5	Start a point on wave	Green	CPOW is not used in Mx70 data models.	TBD	N/A
91	5.11.3	SIMG mix of ...	Green	SIMG is not used in Mx70 data models.	TBD	N/A
92	5.11.4	PresAlm and PresTr	Green	SIML and SIMG are not used in Mx70 data models	TBD	N/A
94	5.3.4	Loc and CDC SPS/SPC?	Green	-Loc is not used	TBD	N/A
95	5.3.4	Proposed called BlkStat	Green	-Proposal was bit accepted	TBD	N/A
96	5.7.3	LN GSAL - OpCntRs	Green	GSAL is not used in Mx70 data models	TBD	N/A
97	5.8.1	LN IARC and OpCntRs	Green	GSAL is not used in Mx70 data models	TBD	N/A
98	5.7.3 5.8.1	GSAL/IARC and NumCntRs	Green	GSAL and IARC Logical Nodes are not used within mx70 data models	TBD	N/A
99	Clause 6	NamPlt of LLN0	Green	The LLN0 contains common information for the LD like Health, Mode and Beh and NamPlt.	?	✓
101	5.5.2	LevMod - disturbance recorder	Green	LevMod is not used	-	N/A
102	5.5.2	RDRE - Sample Rate	Green	New Attribute RDRE sample rate is not applicable	-	N/A
104	5.6.6	LN CSWI - open/close	Green	LN CSWI not used in Mx70 data models	?	N/A
105	5.10.	LN Group M - EEHealth	Green	EEHealth is not used	?	N/A
106	5.10.7.	MMXU – EEHealth	Green	EEHealth is not used	?	N/A
132	5.12.4	SwARsAlm in XCBR	Green	XCBR is not used	?	?
133		LN RREC – Unsuccessful	Green	RREC is not used	-	N/A
134	5.7.2	LN GGIO	Green	More then one Data of the same type is allowed. Data Instances are used (e.g. Ind1, Ind2, Ind3)	?	✓

Num	Doc. Ref.	Subject	Status	Comment	Conformance	Supported
147	p.80, clause 6, Table 9	Mod	Green	Mod is read only	-	N/A
148	5.7.3, 5.8.1	OpCntRs	Green	OpCntRs is not used	?	N/A
152	5.9.3, 5.9.4, 5.9.5	Automatic Voltage Control - AVCO, ATCC, ARCO	on hold		?	?
153		Missing Automatic Infeed Switching	on hold		?	?
199		Input of logical nodes	Green	Duplicate Tissue. See Tissue 216.	?	N/A
208	5.7.3, 5.8.1	NumCntRs - Control?	Green	NumCntRs is not used	?	N/A
209	p.46, 5.7.3	Authorisation Failure	Green	Authorization is not used		N/A
216	5.3.3	Description of LN inputs	Green	New Features to add generic CDC input	Tbd	NA
252	p.31, 5.4.22	PTTR.AlmThm	Green	AlmThm is defined to be of ACT class. The ACT class is not used.	?	NA
256	p.55, 5.10.7	MMXU and rms values	Green	Values of MMXU of CDC WYE/DEL can have two meanings: - with angle present they are phasors and the attribute mag represents the maximum value of the sinusoidal waveform - with angle not present, they should represent rms values. Angle is not present, Mag is rms for A, PhV and PPV	?	✓
257	5.10.2	LN MDIF – Amp1, etc	on hold		?	?
263		Setting Local time or summer/winter time	Green	Proposed to add two new settings to LPHD: - time of next change to daylight saving time - time of next change to standard time These settings would be of new CDC to be defined. The proposed Data objects are not used	?	N/A
264	General	LNs SCBR, SSWI	Green	Ed2: These Logical Nodes (LNs) for condition monitoring information from switchgear are not used	?	N/A

Num	Doc. Ref.	Subject	Status	Comment	Conformance	Supported
268	p.29, 5.4.18	PTOC Enabling Blocking by Harmonic restraint	Green	Unused in Mx70 devices	?	N/A
269	p.30, 5.4.21	PTRC and Switch on to fault	Green	Unused in Mx70 devices	?	N/A
281	p.40, 5.5.9	LN RPSB	Green	Unused in Mx70 devices	?	N/A
283	p.27	SchTyp in LN PSCH	on hold		?	?
288	p.36, 5.5.2	RDRE.RcdTrg	Green	The proposal to trigger a recorder from an external command was not accepted No change to the standard has resulted.	?	N/A
304		Assignment of new letters for logical nodes	on hold		?	?
306	-	Local / Remote	Green	Loc is not used	?	N/A
309		Interval Meter - MITV	on hold		?	?
311	Clause 4	Include (or reject) the suggested Abbreviated Terms in WG17's 61850-420	on hold		?	?
319	71 5.3.3	'behavior' attribute is not required for LLN0	Green	Behavior attribute "Mod" was mandatory and will become optional.	?	N/A
320	p.91, clause A.1.1.2, Para.2	Numbering of extended data	Green	The numbering convention to be applied is unclear in regards to additional Data needed more times than defined in the Logical Node class. AnIn isn't used for the Logical node class in Mx70 devices GosGGIO1 has Data Objects, AnIn1 and AnIn2, but AnIn has been suppressed per Tissue 320	?	✓
324	p.27, 5.4.15	Str in LN PSCH	on hold		?	?
343	p.48, 5.9.4	ATCC.ParOp	Green	The parallel operation attribute in ATCC is not used in Mx70.	?	N/A
360	p.48-49 5.9.4	ATCC.LTCBik <--> ATCC.Auto	Green	The proposal to change attribute name and type was rejected.	-	N/A

Num	Doc. Ref.	Subject	Status	Comment	Conformance	Supported
362	-	SP versus DP on electrical IED inputs	Green	Double point information on model level was introduced because all 4 resulting states have some semantic meaning and not because of communication reliability. No change proposed.	-	N/A
363	-	L/R Security versus Information	Green	Issue for Ed.2: An IED Loc, Local/Remote switch, is not used in Mx70:	?	N/A
467	p.45, 5.7.2, Para 1	GGIO -- Limitation of Floating point set point	Green	New Data Object (DO)	?	N/A
468	p.37, 5.5.3.5.5.4	DR -- Requires more explanation	Green	RADR and RBDR are not used	?	N/A
475	p.92, Annex A.3 all para.	Specialisation of data by use of the number extension	Final proposal		?	?
476	p.49, 5.9.4	ATCC.BIkVLo / BIkVHi	Green	Not used in Mx70 devices	?	N/A
477	p.59, 5.12.1	XCBR.HeatAlm	Green	Not used in Mx70 devices	?	N/A
478	p.46, 5.8.2	emergency off, IHMI.EmgOff	Green	Not used in Mx70 devices	?	N/A
479	-	%-change of measured values	Green	Consider this as a status "Blue" question Tissue.	?	N/A
480	p.58, 5.11.4	SIML.TmpAlm	Green	Not used in Mx70 devices	?	N/A
488	-	Input for Logical Nodes: Data Object binding	Final proposal		?	?
539	-	Dynamic Protection Blocking	Final proposal		?	?
584	p.36, 5.5.2	RDRE missing FullSt	Final proposal		?	?
585	p.36, 5.5.2	RDRE and associated file directory location	Final proposal		?	?
591	-	SIML	Final proposal		?	?

4.11 Part 8-1 Standard

4.11.1 Specification scope

The scope of part 8-1 of the IEC61850 standards covers the specific communication service mapping (SCSM) to the MMS protocol.

4.11.2 Editorial and schema related TISSUES

The following technical issues are editorial and schema related only:

109,110,111,112,115, 117,120,121,123,143,144,

224,227,231,237,276,279,290,299,314,323,344,365,419,430,459

4.11.3 Question only Tissues

The following technical issues are questions only and no compliance is required:

113,131,140,162,167,175,194,200,202,207,225,226,228,229,230,232,238,242,249,301,326,380,466,470

4.11.4 Tissues - Not Applicable for Mx70:

143,144,222,377

4.11.5 Tissues – Unresolved:

246,527,528,535,541,545,547,583,596

4.11.6 Technical Issues

Num	Doc. Ref.	Subject	Status	Comment	Conformance	Supported
114	17.1.1.1 & 17.1.1.2	Naming URCB	Green	Tissue was not accepted	-	N/A
116	8.2.1.3, 9.2.2.3	GetNameList with empty response?	Green	The GetLogicalDeviceDirectory response- should be an MMS GetNamedList response+ with moreFollows=FALSE and a NULL List. If the GetNamedList service is issued for a Domain scoped object and the Domain does not exist, then a Confirmed-Error response with object-non-existent shall be returned.	?	✓
117	18.1.2.5	TimeAllowedtoLive - how long to wait?	Green	Tissue was not accepted, however document is revised so that Client/Server was replaced by Publisher/Subscribers	?	✓

Num	Doc. Ref.	Subject	Status	Comment	Conformance	Supported
118	23.1	File directory	Green	The File list excluded the "Directory". KEMA recommends to always include the directory separator. When the last character of FileName is the file separator "\" it's a directory	?	N/A
119	-	MMS GetCapabilityList required?	Green	Ed 2 - MMS GetCapabilityList service: Services from the SCL-File shall be given as an example in edition 2 GetCapabilityList is not supported because tissue is not clear enough without an example to implement a technical resolution. Issue needs to be further clarified.	?	*
122	25.1.1.1, Table 111	P-Type = IP; DNS name	Green	DNS name is not allowed and is removed form the table	?	✓
128	18, 19	Add DstAddr to GsCB, SV	Green	Mx70 devices do not use GSCB and SVCB in the data models.	-	N/A
165	p.47 14.3.1	Improper Error Response for GetDataSetValues	Green	Issue is regarding an ACCESS error to GetDataSetValues requests executed for a non-existent DataSet (e.g. VGET in MMS), MMS ErrorResponse of Class= ACCESS and Error Code= OBJECT-NON-EXISTENT to be returned	?	✓
168	p.32 7.3.2 Para 2	Order of attributes in MMS components	Green	Within a MMS component, representing IEC 61850-7-4 DATA, the order of MMS components is determined by the order of the names of the common data classes (as defined in IEC 61850-7-3 or IEC extensions of it). For private CDCs the order of attributes within the MMS component shall be identical to the order within the SCL ICD file describing the data model.	?	✓
177	p.52 17.1.1.2 Table 39	Ignoring OptFlds bits for URCB	Green	For an Unbuffered Report Control Block (URCB), the Server ignores the values of bits buffer-overflow and entryID in a write request and the value is always 0 when reading these bits.	?	✓

Num	Doc. Ref.	Subject	Status	Comment	Conformance	Supported
183	p. 39 9.3 Table 17	GetNameList error handling	Green	No change is needed since tissue 116 resolves this issue. The GetServerDirectory service is restricted to return the list of LogicalDevices (e.g. Domains) or a list of Files. Therefore, it is not possible to request a Domain object scope. The text explicitly specifies that the MMS GetNamedList objectClass is Domain. Deleted reference to Table 17 in clause 11. Tissue 116 resolution added text to clause 11 that resolved this issue	?	✓
196	Annex E	SCL for Control	Green	See 173; Add an example in part 6 and 8-1	?	✓
198	see tissue #114	Instantiation of URCB	Green	This is linked to part 6 tissue 243. Unbuffered Report control Blocks (URCBs) are always indexed.	Tbd	✓
235	8.1.3.2	Extension of Name length	Green	The length of names has been expanded; changes are required to adopt to the new name length. Change 65 to 129. Then after the -VMD paragraph add: "The maximum MMS Object Name and Domain Name size shall be constrained by the MMS maxidentifier size of 64 (see Annex G)."	?	✓

Num	Doc. Ref.	Subject	Status	Comment	Conformance	Supported
260	p.93 23.2.4 Para 1	GetFileAttributeValues	Green	<p>Change Clause 23.2.4 (IEC 61850-8-1) to: "The ACSI GetFileAttributeValues should be mapped to a MMS FileDirectory service as expressed in table 83. An ACSI GetFileAttributeValues Request shall cause an MMS FileDirectory request to be issued. Only one answer of the MMS FileDirectory should return with the FileName and FileAttributes of the requested file. This is the information that shall be indicated as part of the ACSI GetFileAttributeValues Response +."</p> <p>Change in Table 83 (col. 2, row 3) "FileName" to "FileSpecification" in the MMS FileDirectory Request to be more accurate.</p>	?	✓
262	p.88 20.8	LastApplError Error codes	Green	<p>Define in Part 8-1 how enhanced security is used: TimeOut Test Not OK shall be returned if a TimeActivated Control CMD is issued, with TEST=TRUE, and the operation fails.</p> <p>Operator Test Not OK shall be returned if an OPER control CMD is issued, with TEST=TRUE, and the operation fails.</p> <p>Error codes are only applicable to enhanced security. Enhanced security is not implemented for Mx70 devices.</p>	?	N/A
292	p. 18 clause 4	Explanation of r and w	Green	<p>Characteristics are clarified as follows: "r = mandates that the item is readable. The ability to write the item is a local issue." "rw"= Mandates that the item is both readable and writeable." "w = Mandates that the item is writeable. The ability to read the item is a local issue."</p>	?	✓

Num	Doc. Ref.	Subject	Status	Comment	Conformance	Supported
368	p.84, p.86, 20.5, 20.7, 20.7.1.3	Mapping of analog setpoints (SP)	Green	<p>Indicate that 7-2 "Value" is mapped to the underlying CDC of the control object. For example, part of PDIS.PoRch setpoint data is mapped to PDIS.PoRch.Oper.setMag.f and allow the setMag structured attribute of setpoints to be used.</p> <p>-Change 3 place 'Where <xxx>' is the appropriate CDC (e.g. ctlVal or setMag)' to 'Where <xxx> is the appropriate CDC (e.g. ctlVal or setMag\$f or setMag\$i)'</p> <p>-The suggestion for Table E.8 shows mxVal for CDC APC. This CDC has only setMag and not mxVal. The M/O/C entry for this line should be as 'M for APC and ASG'.</p> <p>-Tables E.9 and E.10 should be modified like E.8 shown above</p>	?	✓
422	p.34 7.3.1	Order of extension data objects and data attributes	Green	"Within a MMS component, representing IEC 61850-7-4 DATA, the order of MMS components is determined by the order of the names of the common data classes (as defined in IEC 61850-7-3 or IEC extensions of it). For private CDCs, or private Extensions, the order of attributes within the MMS component shall be identical to the order within the SCL ICD file describing the data model."	?	✓
433	p.122-126 Clause E.4	Order of attributes in specialized CDCs for control service mapping	Green	The TISSUE 168 resolves the issue. Normative Annex E (E.3 and E.4) of 8-1 is what is called an IEC extension. The Annex E.3 defines the order of the SBO, SBOw, Oper and Cancel attributes, E.4 the order of the service parameters of the CDCs (ctlVal, origin, ctlNum,...) within SBOw, Oper and Cancel structures.	?	✓
438	p.36 8.1.3.7	EntryTime base should be GMT	Green	EntryTime maps to MMS BINARY-TIME. Clarification was needed that EntryTime is based on GMT.	?	✓

Num	Doc. Ref.	Subject	Status	Comment	Conformance	Supported
446	-	Send only values(not structures) by GOOSE	Blue	Ed.2: IEC61850-7-2, allows Datasets to contain structures or single attributes. Both Structure and single attributes are supported by Mx70 devices.	?	✓
586	-	GOOSE re-transmission & TATL	Blue	Ed.2: 2 Messages are sent within the GOOSE TimeAllowedToLive (TATL) time.	?	✓
587	p.33, 8.1.1	INT128 Range is not usable	Green	Removed INT128 and replace with INT64	?	✓
609	p.125 clause E.4.2	origin and ctrlNum optional?	Blue	Ed.2: Proposal will either make these attributes optional or mandatory. Data attributes Origin and ctrlNum are both present in Mx70 devices.	?	✓

4.12 Part 9-1 Standard (Not supported)

4.12.1 Specification scope

The scope of part 9-1 of the IEC61850 standards covers the specific communication service mapping (SCSM) for sampled values over a serial unidirectional multidrop point to point link.

4.12.2 Technical Issues

The Mx70 IED devices do not support part 9-1 of the IEC61850 standards. TISSUES relating to this part therefore do not affect the application implementation, hence Tissues are not listed in this section.

4.13 Part 9-2 Standard (NOT SUPPORTED)

4.13.1 Specification scope

The scope of part 9-2 of the IEC61850 standards covers the specific communication service mapping (SCSM) for sampled values over ISO/IEC 8802-3

4.13.2 Technical Issues

The Mx70 IED devices do not support part 9-1 of the IEC61850 standards. TISSUES relating to this part therefore do not affect the application implementation, hence Tissues are not listed in this section.

4.14 Part 10 Standard

4.14.1 Specification scope

The scope of part 10 of the IEC61850 standards covers the conformance testing of a device.

4.14.2 Editorial and schema related TISSUES

The following technical issues are editorial and schema related only:

156

4.14.3 Question only Tissues

The following technical issues are questions only and no compliance is required:

372,613

4.14.4 Technical Issues

Num	Doc. Ref.	Subject	Status	Comment	Conformance	Supported
206	5.4.1, 6.2.4.5, 5.5	Add Conformance Blocks	White		?	?
218		Need new test case	Red	Ed.2: GOOSE, in 7-2, allows both FCD and FCDA information to be conveyed. A test case needs to be created that tests an implementation's ability to receive an FCD.	?	?
336	Clause 5.5, last paragraph	Test context	Red	Conformance test documentation shall be supplied to the initiator and made available (on request) to potential customers of the device tested. The test certificate will indicate the conformance test has been performed according to IEC 61850-10 and refer to: : -PICS - IEC 61850 Protocol Information Conformance statement; - MICS - IEC 61850 Model Implementation Conformance statement, and - TICS - technical issue conformance statement. (continued)	?	?

Num	Doc. Ref.	Subject	Status	Comment	Conformance	Supported
		(336 continued from previous page)		- PIXIT - Protocol Implementation extra information for testing” Supplying conformance documentation should not be made mandatory in Part 10		
376	p.25, 6.2.4.9.2	Negative Test case on substitution	White	Mx70 devices do not support substitution.	?	N/A
420	p.20, 6.2.4.3	Configuration file test cases	Red		?	?
421	p.20, 6.2.4.3	Versioning of schema for configuration files	White		?	?
594	p.35, Table 28 Para. CtIN3	Controls to the same direction	Red	XCBR breaker commands are not supported in Mx70 devices.	?	N/A
597	p.35, Table 27	TimeActivatedOperate in 61850-7-2 is not the same to TimeActivation of 61850-8-1	White		?	?

Section 5 PIXIT

Protocol Implementation Extra Information for Testing

5. PROTOCOL IMPLEMENTATION EXTRA INFORMATION FOR TESTING (PIXIT)

5.1 Introduction

This document specifies the **P**rotocol **I**mplementation **e**Xtra **I**nformation for **T**esting (**PIXIT**) of the IEC61850 interface for the Mx70 family of IED measurement devices. Together with the PICS and MICS specifications the PIXIT forms the basis for conformance testing in accordance with part 10 of the IEC61850 standard specifications.

5.2 Document structure

Each section within this specification specifies the PIXIT for each supported ACSI service model as structured in parts 7-2 and 10 of the IEC61850 standard specifications.

5.3 Application Association Model

5.3.1 Maximum Client associations

The maximum number of simultaneously connected clients supported is twenty (**20**).

5.3.2 TCP Keep alive

The TCP_KEEPALIVE function has been implemented according to part 8 of the IEC61850 standard IED to keep-alive messages are not processed.

The interval between the keep-alive messages is configurable between one (1) and twenty (20) seconds, with a setting increment of one (1) second.

The default interval for TCP_KEEPALIVE messages transmitted by the IED is five (**5**) seconds.

5.3.3 Authentication

Authentication for IEC61850 is not supported. Refer to paragraph 2.4

5.3.4 Association parameters

The following parameters are required to be specified when attempting to initiate an association with Mx70 IEDs:

Parameter	Value
Transport selector (<i>tse/</i>)	00 01
Session selector (<i>sse/</i>)	00 01
Presentation selector (<i>pse/</i>)	00 00 00 01

The following parameters are only required if write permission should be granted. The values are not checked, only the presence of the parameters is used to grant complete write permission. Unless both parameters are present, writes to many objects are disallowed.

Parameter	Value
AP Title	1,3,9999,106
AE Qualifier	33

5.3.5 Aborting associations

When a client aborts its association the TCP/IP socket is not immediately closed down by the IED. This is a standard operating principle to ensure that any delayed or out-of-order frames are correctly processed before closing down the socket.

The time-out period for aborted sockets is approximately sixty (**60**) seconds. For the duration of this time-out period the socket resources are unavailable for new client association requests.

A total of 100 sockets are available but it should be noted that these resources are shared with other network tasks (for example SNTP time synchronisation). If no sockets are available the IED will refuse new association requests from a client.

5.3.6 Loss of link detection

Mx70 devices support loss of network link detection. The device will automatically attempt to connect back onto the network using alternating copper/fibre interfaces.

Any client associations will be automatically aborted if the network link is not re-established after a maximum of thirty (**30**) seconds.

5.3.7 MMS PDU Size

The maximum supported MMS PDU size is **10000 bytes**, while the minimum supported MMS PDU size is **1000 bytes**.

In order to reduce the impact of file transfers during concurrent real-time data transfers, the file transfers are always segmented into a configuration-defined block size (default 1000 octets) regardless of the negotiated PDU size

5.3.8 Startup time

The typical start-up time of basic Ethernet services, following an interruption to the power supply, is approximately 65 seconds. Full IEC61850 services are available after an approximate start-up time of 65 seconds.

5.4 Server Model

Table 3: PIXIT for Server Model

Description	Value/Clarification
Which analogue value (MX) quality bits are supported (can be set by server)	Validity: Y Good Y Invalid N Reserved N Questionable N OverFlow Y OutotRange N BadReference N Oscillatory Y Failure Y OldData N Inconsistent N Inaccurate Source : Y Process N Substituted N Test N OperatorBlocked
Which status value (ST) quality bits are supported (can be set by server)	Validity: Y Good Y Invalid N Reserved N Questionable N BadReference N Oscillatory Y Failure Y OldData N Inconsistent N Inaccurate Source : Y Process N Substituted N Test N OperatorBlocked
What is the maximum number of data values in one GetDataValues request	Stack does not limit the amount of the data values. MMS PDU is the limit.
What is the maximum number of data values in one SetDataValues request	Stack does not limit the amount of the data values. MMS PDU is the limit.

5.4.1 Data quality (Measurements and Status Points)

The Mx70 measurement IED range of products does not support the concept of IEC61850 quality information, as such all quality data attributes return a fixed value of zero (0) indicating the quality of data is good.

5.4.2 Get / Set data values services

The maximum number of data values supported in one *GetDataValues* and *SetDataValues* service request is dependant upon the following elements:

- The maximum negotiated size of the MMS PDU
- The total length of all *ObjectReferences* to be included within the service request

That is to say, the total length of all *ObjectReferences* must be less than the maximum supported MMS PDU size, taking into account any relevant header information.

5.4.3 Measurement deadbands (NOT SUPPORTED)

Deadbands are not supported in Mx70 IED devices. As a result instantaneous values are used in the Data set model when reporting mag attributes.

5.5 Data Set Model

Table 4: PIXIT for Data Set Model

Description	Value/Clarification
What is the maximum number of data elements in one data set	250 data attributes The number of elements in each reported data set is directly dependant upon the count of data attributes contained within the MX or ST functional constraints, as reported by the Report Control Blocks in each Logical Node instance. None of the pre-defined data sets can be deleted.
How many persistent data sets can be created by one or more clients	0
How many non-persistent data sets can be created by one or more clients	Not supported service
User definable data sets	26 (at configuration time) Dynamic creation of any type of user-defined data set, either persistent or non-persistent is not supported.

5.6 Substitution Model (not supported)

5.6.1 Measurement and status point substitution (NOT SUPPORTED)

The substitution model for measurements (MX functional constraint) and status points (ST functional constraint) is not supported in Mx70 IEDs.

5.7 SettingS Group Control Model (not supported)

The Settings Group Control Model is not supported in Mx70 devices.

5.7.1 Configuration

The Mx70 devices do not support on-line setting changes of elements over the IEC61850 interface

Configuration of Mx70 devices is achieved through the use of the following software tools that are provided:

- Bitronics 70Series Configurator software,
- Areva T&D's MiCOM S1 IED Configurator software package.

○

5.8 Reporting Model

Table 7: PIXIT for Reporting Model

Description	Value/Clarification																		
Supported Report Control Block types	Mx70 devices support the following Report Block services: 32 unbuffered Report Control Blocks (URCB) 4 Buffered Report Control Block (BRCB)																		
The supported trigger conditions are	<table border="0"> <tr><td>Integrity</td><td>Y</td></tr> <tr><td>data change</td><td>Y</td></tr> <tr><td>quality</td><td>Y</td></tr> <tr><td>data update</td><td>N</td></tr> <tr><td>general interrogation</td><td>Y</td></tr> </table> <p>Attempts to enable trigger conditions that are not supported (N) will result in a negative response being returned.</p> <p>The supported trigger options are set in the devices IED Capability Description (ICD) file to define the IED's reporting capability. This is not to be confused with the actual devices configuration, which would normally be represented in a Configured IED Description (CID) file</p>	Integrity	Y	data change	Y	quality	Y	data update	N	general interrogation	Y								
Integrity	Y																		
data change	Y																		
quality	Y																		
data update	N																		
general interrogation	Y																		
The supported optional fields are	<p>The following optional fields can be included in unbuffered reports created by Mx70 devices:</p> <table border="0"> <tr><td>sequence-number</td><td>Y</td></tr> <tr><td>report-time-stamp</td><td>Y</td></tr> <tr><td>reason-for-inclusion</td><td>Y</td></tr> <tr><td>data-set-name</td><td>Y</td></tr> <tr><td>data-reference</td><td>Y</td></tr> <tr><td>buffer-overflow</td><td>N</td></tr> <tr><td>entryID</td><td>Y</td></tr> <tr><td>conf-rev (configuration revision)</td><td>Y</td></tr> <tr><td>segmentation</td><td>N</td></tr> </table>	sequence-number	Y	report-time-stamp	Y	reason-for-inclusion	Y	data-set-name	Y	data-reference	Y	buffer-overflow	N	entryID	Y	conf-rev (configuration revision)	Y	segmentation	N
sequence-number	Y																		
report-time-stamp	Y																		
reason-for-inclusion	Y																		
data-set-name	Y																		
data-reference	Y																		
buffer-overflow	N																		
entryID	Y																		
conf-rev (configuration revision)	Y																		
segmentation	N																		
Can the server send segmented reports?	<p style="text-align: center;">Y</p> <p>Reports will be segmented, and sent with sub-sequence numbers, if the data is too big to fit into a single MMS frame.</p>																		

Description	Value/Clarification
<p>Mechanism on second internal data change notification of the same analogue data value within buffer period (Compare IEC 61850-7-2 §14.2.2.9)</p>	<p>Analog change reporting:</p> <ol style="list-style-type: none"> 1. Integer analogue value changes trigger a report to be sent immediately upon the second integer value change or upon the expiration of the buffer timer designated as buftim. 2. A floating point analogue value change never triggers reports, but the floating point analogue values are updated in the pending report.
<p>Multi client URCB approach (Compare IEC 61850-7-2 §14.2.1)</p>	<p>Each client is assigned its own set of Unbuffered Report Control Blocks (URCB's)</p> <p>This allows clients to enable reporting based on their own requirements rather than having to share URCB resources with all other (connected) clients.</p> <p>Each Unbuffered Report Control Block can be used by at most one client. Clients should set Resv then set remainder of URCB, then enable the report. Reports enabled by another client cannot be altered.</p> <p>As each client is assigned its own URCB, the use of the reserve attribute becomes redundant although this is still supported within the control block.</p>
<p>What is the format of Entry ID</p>	<p>Octet string 8, four Least Significant bytes are used as counter</p>
<p>What is the buffer size for each BRCB or how many reports can be buffered.</p>	<p>25 000 bytes per report control block. ~100 single event reports.</p>
<p>Pre-configured RCB attributes that cannot be changed online when RptEna = FALSE (see also ICD report settings)</p>	<p><data set name> <configuration revision></p>
<p>May the reported data set contain structured data objects?</p>	<p>Y</p>

5.9 Logging Model (Not supported)

5.9.1 Event logging

Mx70 devices do not support IEC61850 logging services, hence there are no Log Control Blocks (LCB) exposed within the data model.

For Mx70 devices there is an existing measurement event log that is used to store historical data. This is only available through the soelog.txt file.

5.10 Generic Substation Events Model

5.10.1 Supported GSE models

Mx70 IEDs support IEC61850 GOOSE. GSSE, formerly UCA2 GOOSE, is not fully supported. However, GSSE messages are issued by the server under some conditions and GSSE reception can cause internal state changes (through 70Series Configurator).

5.10.2 GOOSE Service support

The following GOOSE services are supported by Mx70 devices:

- SendGOOSEMessage
- GetGoReference
- GetGoCBValues

The *SetGoCBValues* service is not supported, although it is possible for connected clients to change the *GoEna* attribute online.

5.10.3 Subscription to publishing IEDs

5.10.3.1 Message validation

The following elements of a GOOSE message header are checked in order to determine the messages validity prior to processing its data within the IEDs GOOSE scheme:

- **Destination MAC address**,
- **Frame Ethertype**,
- **AppID**
- **Time Allowed to Live**, which is expected to be a value greater than zero (0).
- **DatSet**, which is expected to be a valid reference as taken from the publishing devices *GoCB* during device configuration (from *SCL*) and not a *NULL* value.
- **GoID**, which is expected to be a valid reference as taken from the publishing devices *GoCB* during device configuration (from *SCL*) and not a *NULL* value.
- **ConfRev**, which is expected to match the publishing devices *GoCB* as set during device configuration (from *SCL*).
- **numDatSetEntries**, but only after an initial message from the publishing device has been received and the device has been enrolled. At this point each subsequent message must contain the same number of data set elements as the first received message.

The following elements of the GOOSE message header are not checked during validation of received messages:

- Source MAC address
- VLAN id and priority
- *GoCBRef*
- *t*
- *stNum*
- *sqNum*
- *test*

5.10.4 Data processing

The data received in a GOOSE message is only processed when a change in status number (*stNum*), taken from the GOOSE message header, is detected. No validation checks are made to ensure the data has changed inline with the *stNum* increment and it is accepted and processed as per the normal procedure given below.

The data is transferred onto Boolean, Integer, and Float values. Boolean and Integer input values can be converted to Boolean values when the data subscription parameters are met:

Virtual Input State	Criteria
True On	The received data value matches the virtual inputs target value in accordance with its comparison operator.
False Off	The received data value does not match the virtual inputs target value in accordance with its comparison operator.

Mx70 IEDs support thirty-two (32) each of Boolean, Integer, and Float virtual input signals each with their own GOOSE data set attribute index, target value and comparison operator. The following comparison operators are supported:

- GOOSE data value **EQUALS** target value
- GOOSE data value **IS NOT EQUAL TO** target value
- GOOSE data value **IS LESS THAN** target value
- GOOSE data value **IS GREATER THAN** target value

Only the following basic data attributes of a basic data-type can be decoded from the incoming GOOSE data set elements:

- Unsigned integer – 32bits, 16bits & 8bits
- Signed integer – 32bits, 16bits & 8bits
- Boolean
- Bit-string 2

Additionally, the following structure types can be decoded:

- SPS (Single point status)
- DPS (Double Point status)

5.10.4.1 Duplicated, out-of-order and missed messages

No checks are made for duplicated or out-of-order GOOSE messages. They are validated in accordance with the rules given in section 5.10.3.1 and the data is transferred onto the virtual inputs as per section 5.10.4.

GOOSE messages received with non-contiguous state / sequence numbers will be processed as normal.

No alarm or warning conditions are reported for any of these conditions.

5.10.4.2 Time Allowed to Live (TAL)

If a GOOSE message from one of the subscribed publishers is not received within the TAL taken from the last valid GOOSE message from that publisher, *the value reverts to its default value (non-float) or remains at the last known value (float)*.

It should be noted that this single alarm provides a Logical OR of all publishing IEDs that the Mx70 device has subscribed to. This alarm therefore remains set while there are one (1) or more publishers absent.

It is not possible from this alarm condition to identify which publishing device has exceeded its TAL and has been classed as absent.

5.10.4.3 Needs commissioning and Test flags

If a GOOSE message is received and the *NdsCom* and/or *test* flags are set the message will be accepted as valid [The TAL will be updated thus ensuring the device is classed as fully subscribed within the relays GOOSE scheme], however the message data will not be extracted nor processed within the IEDs GOOSE scheme logic.

Any Virtual Input that is driven by the incoming GOOSE message (flagged as *NdsCom* or *test*) will revert to its configured default value.

5.10.4.4 Data set reconfiguration

Under normal circumstances a change to the data set published in a GOOSE message will result in an increment of the GOOSE Control Block (GoCB) *ConfRev* attribute.

If the relay has subscribed to a device that changes its published data set without incrementing the *ConfRev* attribute, it will attempt to extract and decode the data as normal. If successful the data will be processed as described in section 5.10.4 however it should be noted that it will be a different data set element that is now driving the virtual input value. No alarm or warning conditions are reported for this situation.

If the Mx70 device is unable to extract and decode the data then the GOOSE message will be considered invalid and will be discarded.

5.10.4.5 Default values

For the following conditions, a virtual inputs value will be forced to its configured *default value*:

- The publishing device is absent (e.g. no GOOSE messages are received).
- The received GOOSE message does not pass the validation criteria given in section 5.10.3.1.
- The received GOOSE message has the *test* flag set.
- The received GOOSE message has the *NdsCom* flag set.

5.10.5 Publication

5.10.5.1 Pre-configured attributes

The following pre-configured attributes of the GOOSE Control Block (GoCB) can not be changed, either during device configuration (from SCL) or online by a connected client:

- *DatSet* [Data set to transmit]
- *NdsCom* [Needs commissioning]

The *DstAddress* (Destination Address) data object of the GoCB is configurable from SCL but can not be changed online by a connected client.

5.10.5.2 Commissioning

The data set assigned to the GOOSE Control Block is pre-configured and can not be modified at system configuration time or by a connected client. As such the *NdsCom* (Needs commissioning) attribute is fixed to FALSE.

5.10.5.3 Transient data attributes

Mx70 IEDs will publish both state-transitions (Off->On, On->Off) of transient or pulsed data attribute values (e.g. a trip).

5.10.5.4 Number of messages during Time Allowed to Live Interval

The Mx70 IEDs will attempt to send 2 GOOSE messages during the published Time Allowed to Live (TAL) interval. This allows subscribers to miss any single GOOSE packet without raising any alarms.

5.11 Transmission of Sampled Values Model (NOT supported)

5.11.1 Modes of operation (NOT SUPPORTED)

Mx70 IEDs do not support transmission of sampled value services using any modes of operation (multicast or unicast). As such there are no Multicast Sample Value Control Blocks (MSVCB) or Unicast Sample Value Control Blocks (USVCB) exposed within the data model.

5.12 Control Model

5.12.1 Modes of operation

Table 11: PIXIT for Control Model

Description	Value/Clarification
What control modes are supported	Y status-only Y direct-with-enhanced-security Y sbo-with-normal-security N direct-with-enhanced-security N sbo-with-enhanced-security
Is Time activated operated (operTm) supported	N
What is the behavior when the test attribute is set in the SelectWithValue and/or Operate request	No functionality
What are the conditions for the time (T) attribute in the SelecWithValue and/or Operate request	No functionality
Is “operate-many” supported	Y (via configuration; initialized but can't change after configuration)
Is pulse configuration supported	N (via configuration)
What check conditions are supported	N synchrocheck N interlock-check

Description	Value/Clarification
What service error types are supported	N instance-not-available N instance-in-use Y access-violation N access-not-allowed-in-current-state N parameter-value-inappropriate N parameter-value-inconsistent N class-not-supported N instance-locked-by-other-client N control- must-be-locked Y type-conflict N failed-due-to-communications N constraint failed-due-to-server-constraint
What additional cause diagnosis are supported	N Unknown N Blocked-by-switching-hierarchy N Select-failed N Invalid-position N Position-reached N Parameter-change-in-execution N Step-limit N Blocked-by-Mode N Blocked-by-process N Blocked-by-interlocking N Blocked-by-synchrocheck N Command-already-in-execution N Blocked-by-health N 1-of-n-control N Abortion-by-cancel N Time-limit-over N Abortion-by-trip N Object-not-selected
How to force a "test-not-ok" respond with SelectWithValue request?	SelectWithValue is not supported
How to force a "test-not-ok" respond with Operate request?	Not possible
Which origin categories are supported? What happens if the orCat is not supported?	No checking, All are supported
Does the IED accept a select/operate with the same ctlVal as the current status value?	Yes
Does the IED accept a select/operate with the same control object from 2 different clients at the same time?	No

Description	Value/Clarification
Selection of objects	One object at a time can be selected; no limit
Command checking	-command checking based on client identification -ctlVal is forwarded to IED and the value is checked in application -other command control structure attributes are stored and used for responses
Internal command timeout	Select timeout interval applies

5.13 Time and Time SynchroniZation

Table 12: PIXIT Time and Time Synchronization Model

Description	Value/Clarification
What quality bits are supported	N LeapSecondsKnown N Clock Failure N Clock NotSynchronized
What is the behavior when the time synchronization signal/messages are lost	No action
When is the quality bit “Clock failure” set?	Quality bit is not supported
When is the quality bit “Clock not synchronized” set?	Quality bit is not supported
SNTP Request interval	Variable

5.13.1 Time quality

Historical data logged by Mx70 IEDs do not include any quality information with respect to timestamps. For this reason none of the time quality bits are supported and are fixed at a value of zero (0) for all timestamp attributes.

5.13.2 Time accuracy

The time accuracy of Mx70 IEDs is to ten (10) significant bits of the *FractionOfSecond* attribute. This equates to approximately one (1) millisecond, meeting the requirements of performance class T1 as defined in part 5 of the IEC61850 standards.

5.13.3 External synchronization

Mx70 IEDs can be configured with two (2) external time synchronization servers, of which only 1 is ever the active time synchronisation source.

If an external source fails to respond to a client synchronisation request, or responds with an invalid/unsupported message, the IED will automatically switch to the unused source, if configured.

Manycast mode of SNTP is fully supported but users are strongly cautioned to verify behaviour of their systems before enabling the manycast mode.

5.13.4 SNTP server operation

Mx70 IEDs are not intended to be used as an external time synchronisation source.

5.13.5 IRIG-B

If IRIG-B is enabled (via configuration) and a valid signal is being received by the IED, then SNTP server responses will be ignored as IRIG-B is deemed to be the primary source of time synchronisation.

If IRIG-B becomes unavailable during normal operating conditions, SNTP will become the active time synchronisation source until such time that IRIG-B becomes available once again. However, it is recommended that only a single time source type to be used.

5.14 File Transfer Model

Table 13: PIXIT Time and Time Synchronization Model

Description	Value/Clarification
What is structure of the file and directories	<p>Mx70 IEDs use MMS file transfer services for the transfer of disturbance records. The file structure and directory presented to the user is shown in the following tree structure:</p> <pre> Device Root/ COMTRADE/ {IEDNAME}.icd} soelog.txt LD/ {IEDNAME}Measurements/ {IEDNAME}Records/ {IEDNAME}System/ </pre> <p>Files soelog.txt and the icd file are stored in the device's root directory. Disturbance recorder files are stored in the Comtrade directory (for example: Comtrade/DR1_0001.zip).</p>
Is the IETF FTP protocol also implemented	Yes, The File Transfer Protocol (FTP), as defined by the Internet Engineering Task Force (IETF), is supported as well
Directory names are separated from the file name by	<p>Forward slash character, "/"</p> <p>The use of MS-DOS directory separator characters ('\') will return a positive result to the file transfer MMS service requests but with no data elements (directory or filenames).</p>

Description	Value/Clarification
The maximum file size including path (recommended 64 chars)	256
Are directory/file name case sensitive	N
Maximum file size	Maximum file size is not defined. Free space varies and depends completely on configuration. The maximum file size is limited by the maximum number of data elements and number of clients. Maximum file size is not restricted over the MMS file transfer interface. (Refer to the section covering the PIXIT for Data Set Model)
Is the file path included in the file name in the MMS fileDirectory respond?	Y

5.15 Sub-station Configuration Language

5.15.1 Conformance level

Mx70 IEDs are conformant to **SCL.1** as defined by part 8 of the IEC61850 standards; annex D.

ICD template files are available within the MiCOM S1 IED Configurator application.

5.15.2 Private data

The Mx70 ICD files contain private SCL data. This is required by the IED configurator tool in order to correctly extract, process and configure a relay.

Any tool that imports Mx70 ICD files is required to preserve the private data in accordance with part 6 of the IEC61850 standards.

5.15.3 IED Name

The Sub-station Configuration Language (SCL) allows customisable IED names. Mx70 IEDS support user-definable IED names, however these are restricted to a maximum of **eight (8)** characters in length.

5.16 IED Configurator

5.16.1 Configuration banks

Mx70 devices support two (2) configuration banks for holding IED configurations taken from SCD or CID Substation Configuration Language (SCL) files. This includes IP configuration, SNTP, GOOSE publishing/subscription parameters etc.

The IED Configurator tool only allows a configuration to be downloaded to the inactive bank. The IED Configurator will prompt the user if he/she desires to make the configuration active.

Revision	Date	Changes	By
A	01/30/2009	Update Bitronics Name, Logo	E. DeMicco
B	05/01/09	Updated logos and cover page	MarCom
C	9/22/09	Updated firmware history	E. DeMicco
D	9/30/10	Corrected information on Fault Location Logical Node in section 3.4.16	E. DeMicco
E	12/5/11	Corrections to number of URCBs and BRCBs and BRCBs conformance in tables A.2 and A.3	E. DeMicco



Bitronics LLC, 261 Brodhead Road, Bethlehem, PA. 18017
(610) 997-5100 Fax (610) 997-5450
www.novatechweb.com/bitronics