



TOUCH SENSOR

TYPE: B6TS-08NF

USER MANUAL



# Introduction

Thank you very much for purchasing the touch sensor.

The touch sensor is a product that has been developed based on Omron's advanced technology and rich experience. This user manual describes the information necessary for use of the sensor, such as its functions, capabilities and proper usage.

When using the touch sensor, please keep the following in mind:

- Only specialists with knowledge of electricity must handle the touch sensor.
- Please read and understand the contents of this manual thoroughly to use the touch sensor appropriately.
- Keep this manual handy to refer to at any time you need it.

## Points to note when using the touch sensor

- Although Omron makes constant efforts to improve the quality and reliability of its semiconductor products, products such as this touch sensor may malfunction or break. Before using the touch sensor, please contact Omron's business development personnel, if necessary, to confirm product specifications, while also paying attention to using the sensor with a sufficient margin allowed for its ratings and capabilities, and taking safety measures such as installing safety circuits to minimize hazards in the unlikely event that a failure of the sensor might occur.
- Basically, this product is not designed and manufactured for use in equipments or systems operated under potentially hazardous conditions. If you intend to use the touch sensor with any of the following systems, facilities or equipment, be sure to consult Omron sales personnel or an agent or dealership first:
  - (A) Atomic power control equipment, incineration facilities, railroads, aircraft, vehicle equipment, medical appliances, amusement machines, safety devices, and facilities that must comply with the regulations of administrative agencies and their respective industries.
  - (B) Systems, machines and devices that are potentially hazardous to humans and property.
  - (C) Other usages that require a high degree of safety.

The technical information contained in this manual is prepared only to describe typical performances and application examples of the product. Application of the products based on the information does not infer the grant of any Omron or third party intellectual property, right or license.

1. Preventing malfunction caused by contact with an electric conductor other than a human finger with the touch electrode  
Because this product measures the electrostatic capacitance of the detector (electrode), the product may operate if something other than a human finger is brought into contact with the electrode. Therefore, a fail-safe design is required for use of the product so that it does not cause any functional or safety problem even on such occasions. Substances, etc., that may cause a malfunction if they are present near to or on the detector are:
  - Water, metal, animals, other conductive materials
2. Preventing operational error  
Because this product detects human touch, it may operate if the detector (electrode) is touched only lightly or if somebody remains nearby. When incorporating this product into a device, check the detection range thoroughly, and employ measures to prevent the device from malfunctioning caused by operational error. Especially, if the device is used where children may come into contact with it, provide some safety measure such as a child safety lock.
3. Preventing the entry of water or corrosive gases  
If water or a corrosive gas enters the operating part of the sensor (electrode), in the event of a short circuit or corrosion of the electrode, the sensor may malfunction or its detection sensitivity may be lowered. If the product is supposed to be used in an environment where this may occur, employ some structure to prevent the entry of water or gas, and check to be sure in actual operation that the device is protected securely against such an event.
4. Preventing malfunction caused by noise  
The product may malfunction if subjected to excessive noise.  
Check to be sure that no safety problems are caused by excessive noise.
5. Preventing direct touching of the electrode

Do not employ any structure that exposes the surface of the touch electrode to the air and allows somebody to touch the metal part of the touch electrode directly. Otherwise, the safety of the product may be impaired, accumulated electrostatic charges may damage the product, or the electrode may corrode. Adopt a structure that covers the surface of the touch electrode with nonconductive material and does not allow anybody to touch the metal part of the electrode directly.

The recommended thickness for the nonconductive material is:

Resin material (dielectric constant of 2 to 3): no more than 2mm

Glass material (dielectric constant of about 5): no more than 4mm

## Proper usage

### 1. Method of transportation and storage

- 1) Do not drop or apply any shock to the touch sensor because it is a precision device.  
If the sensor is thrown or dropped, it may break.
- 2) When carrying or storing the touch sensor, keep its packaging properly oriented.  
If the packaging is placed upside down or tilted, the sensor may be subjected to some undue force and may break.
- 3) Store the touch sensor under the following conditions to prevent the package from absorbing moisture:  
Otherwise, the sensor may break when the package is mounted.  
<Storage conditions>
  - A. Before opening the moisture-proof pack (aluminum laminate pack):  
[Temperature, humidity] 5-40°C, 20-80% RH  
[Term of validity] One year  
When the sensor is used after a long period of storage, make sure that no damage, dirt, or rust is present on the pack.
  - B. After opening the moisture-proof pack (aluminum laminate pack):  
Until the package is mounted, the following conditions are recommended for storage of the package:  
[Temperature, humidity] No higher than 30°C, No more than 70% RH  
[Term of validity] One week
  - C. Temporary storage after opening the moisture-proof pack:  
When storing an unused sensor package temporarily, restore the package together with some desiccating agent into a moisture-proof bag as early as possible (within about 10 minutes), fold the opening of the bag in two, seal the bag tightly with adhesive tape or the like, and keep the bag under the following recommended conditions:  
[Temperature, humidity] 5-40°C, 20-80% RH  
[Term of validity] One month
- 4) Do not use or store the touch sensor where it will be subject to corrosive gases such as hydrosulfuric gas or salt air, or exposed to oil or direct sunlight.
- 5) Where either of the following conditions [1] or [2] is applicable, baking the sensor package in the following manner is recommended in order to remove moisture:  
The tray used in the moisture-proof pack can be stored in a high-temperature chamber because it is heat-resistant. However, place the tray on a flat base such as a level block, and then cool it down on the base to prevent deformation after baking.  
[1] The above storage conditions A-C are exceeded.  
[2] The color of the 30% RH detection part of the indicator changes to lavender or pink.

<Baking method>

[Temperature] 125°C

[Time] 20-24 hours

[Number of times baking] Up to three

(Cumulative time limit: 72 hours)

### 2. Measures against electrostatic charges during handling

Keep the relevant electric equipment, work-bench and worker at the same potential.

Lay a conductive mat with a surface resistance of 10 kΩ - 10 MΩ on the work-bench, and ground the mat.

The worker must make sure that there is no electric leakage from the electric equipment and ground himself/herself through a resistor of about 1 MΩ for safety.

All safety regulations must be observed.

Any electric leakage from the electric equipment is undesirable from the viewpoint of worker safety.

Check to be sure that there is no electric leakage from the tester, curve tracer, oscilloscope, or the like, and then

ground the equipment. Any electric leakage can break the MOS IC.  
The same precautions apply to soldering irons.

### 3. Recommended soldering conditions

Temperature conditions for mounting the IC chip

When mounting the IC chip at a high temperature using reflow soldering, the melting temperature of the solder depends on the mounting board and paste adhesive materials. Referring to the mounting temperature profile shown in Fig. 1, choose the optimum soldering temperature within the profile.

[1] Reflow method (infrared light reflow and air reflow)

- [Number of times] Up to three times  
(Complete the last reflow under storage condition B in Section 1.)
- [Temperature] The surface temperature profile of the device is shown in Fig. 1.

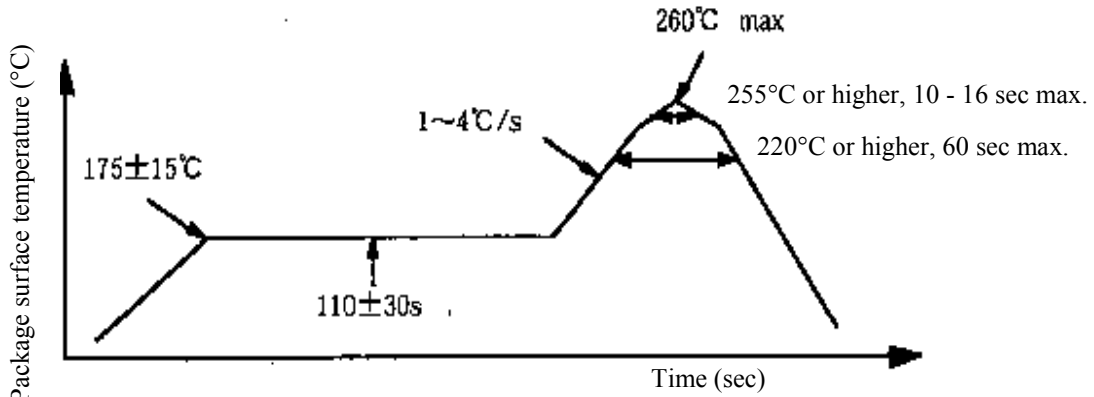

Fig.1 Reflow method temperature profile

[2] Wave soldering method (known as flow soldering or dip soldering)

- [Number of times] Once
- [Temperature] The temperature profile is shown in Fig. 2.  
(The optimum preheating temperature must be set according to the type of flux.)

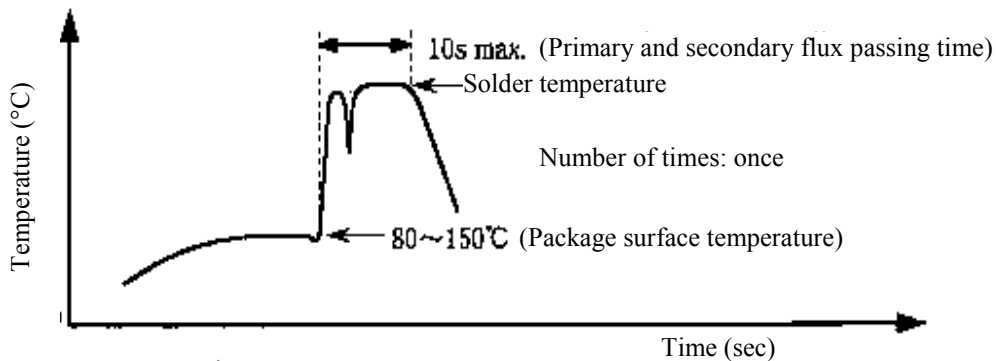

Fig.2 Wave soldering method temperature profite

[3] Soldering iron (manual soldering)

Solder using a soldering iron for semiconductor devices under the following conditions:

- [Iron tip temperature] No higher than  $370^\circ\text{C}$
- [Soldering time] No longer than 5 sec/pin

4. Recommended wash conditions

When using rosin flux wash, check the following items:

- 1) Amount of contamination containing residual ions (or no ions)
- 2) Administrative directions and regulations
- 3) Melting resistance of parts

5. Handling after mounting parts on PWB

When dividing a PWB on which ICs are mounted, do not apply any excessive force to the ICs. Otherwise, the internal IC chips may be broken.

6. Applied voltages and currents

- 1) Do not apply to any pin any voltage or current that exceeds the maximum absolute rating.
- 2) Use the device within the recommended specifications to enhance the quality of the device.
- 3) Do not apply any forward bias to any of the pins. Otherwise, excessive forward current may cause thermal breakdown of the IC.
- 4) Do not connect any output pin directly to power. If any output pin is directly connected to low-impedance power, the internal wiring may melt down or break thermally due to excessive current.

# CONTENTS

1. Overview
2. Pin connections
3. Operation modes
4. Measurement
5. Serial communication
6. Commands
7. Teaching
8. Electrical characteristics
9. Appearance and dimensions

## 1. Overview

This chip is a sensor IC to detect micro capacitances and can be used in touch sensors. Internally, the chip employs the CMOS process and is contained in a 32-pin QFP plastic package. The IC has 8 independent measurement pins, each of which can measure capacitance independently. On/off output or serial communication output can be selected as the output form. The IC is provided with an EEPROM that can store operation mode and other parameters.

## 2. Pin connections

### 2.1 Pin arrangement diagram

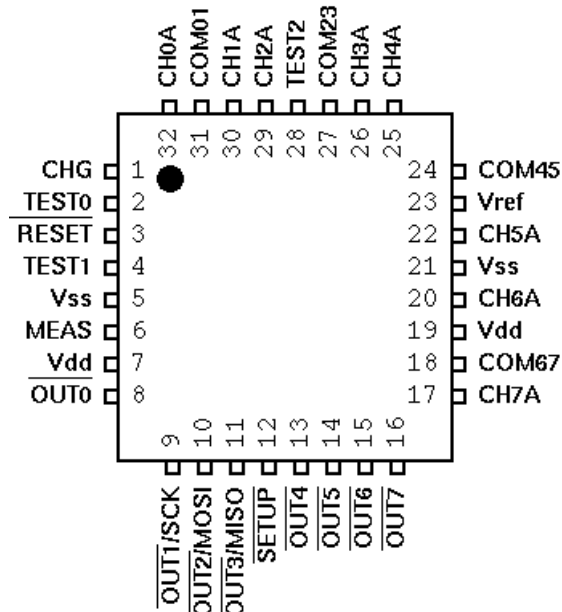

Note 1: Pins TEST0 - 2 are used for testing during manufacture of the IC.

When using these pins:

TEST0: Connect to Vss through a pull-down resistor.

TEST1 and TEST2: Connect to Vdd through a pull-up resistor.

Note 2: Pin Vref is provided to stabilize internal power. When using this pin, connect it to Vss through a capacitor of about 0.1  $\mu$ F.

### 2.2 Pin functions

Pin No.	Designation	Input/Output	Function
1	CHG	O	Indicates the chip's operational status. [Normal measurement mode] Outputs when measurement is complete. Two output modes are available: 1. High-signal output every time a measurement finishes. 2. High-signal output when the condition changes in any one of the channels (touch→no touch, no touch→touch). [Setup mode] When setup mode is entered, CHG pin is high. However, when EEPROM write command is received and data is being written in EEPROM, CHG pin is low.
2	TEST0	I	(Connect to Vss through a pull-down resistor.)
3	RESET	I	Reset signal input. Inputting low to this pin resets the chip. Connect this pin to VDD through a pull-up resistor of about 5 k $\Omega$ . When VDD starts up, the power-on reset function operates and the chip is initialized. When the power-on reset function is used, no other reset signal is needed when power is turned on.
4	TEST1	I	(Connect this pin to Vdd through a pull-up resistor)
5,21	Vss	I	Ground



<i>Pin No.</i>	<i>Designation</i>	<i>Input/Output</i>	<i>Function</i>
6	MEAS	I	Initiation of measurement. Capacitance measurement is initiated by inputting high to this pin. While low is input to this pin, the chip is held in standby status.
7,19	Vdd	I	Supply input (4.5 - 5.5V)
8	$\overline{\text{OUT0}}$	O	Output pin for channel 0 (active low)
9	$\overline{\text{OUT1}}$ SCK	I/O	Output pin for measured result [On/off output mode] channel 1 output (active low) [Serial communication mode] serial communication clock input
10	$\overline{\text{OUT2}}$ MOSI	O	Output pin for measured result [On/off output mode] channel 2 output (active low) [Serial communication mode] serial communication clock input
11	$\overline{\text{OUT3}}$ MISO	I/O	Output pin for measured result [On/off output mode] channel 3 output (active low) [Serial communication mode] serial communication clock input
12	$\overline{\text{SETUP}}$	I	Setup mode. Low input to this pin moves the chip into setup mode.
13	$\overline{\text{OUT4}}$	O	Output pin for channel 4 (active low)
14	$\overline{\text{OUT5}}$	O	Output pin for channel 5 (active low)
15	$\overline{\text{OUT6}}$	O	Output pin for channel 6 (active low)
16	$\overline{\text{OUT7}}$	O	Output pin for channel 7 (active low)
17, 20, 22, 25, 26, 29, 30, 32	CH7A CH6A CH5A CH4A CH3A CH2A CH1A CH0A	I/O	Measurement pins (channel 7 - 0) Connect these pins to the touch electrode through resistors.
18, 24, 27, 31	COM67 COM45 COM23 COM01	I/O	Common-use measurement pins (channel 7 - 0) Common-use measurement pins for two channels each Connect these pins to charge capacitors through resistors.
23	Vref	I	Pin for stabilization of internal power Connect this pin to Vss through a capacitor of about 0.1 $\mu\text{F}$ .
28	TEST2	I	(Connect to Vdd through a pull-up resistor)

## 2.3 An example circuit

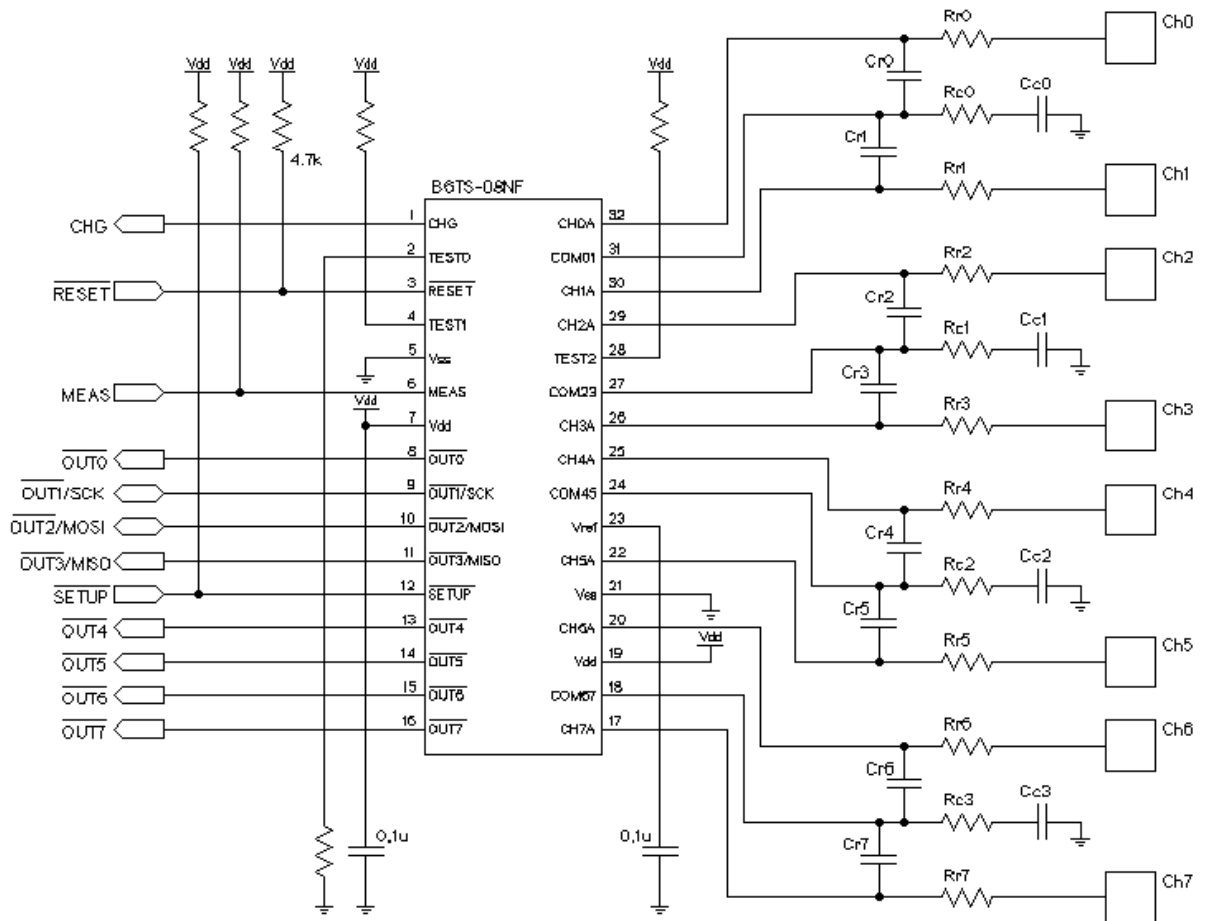

Note 1: Connect  $R_r$ ,  $C_r$ ,  $R_c$ , and  $C_c$  to each touch electrode, as shown in the above figure. Refer to the design tool (B6TWWorkbench) for their actual values.

- $R_r$ 0-7: Protective resistors
- $C_r$ 0-7: Capacitors for comparison
- $R_c$ 0-3: Resistors for charge control
- $C_c$ 0-3: Charge capacitors

Note 2: Connect a bypass capacitor of about 0.1  $\mu$ F between Vdd and Vss using as short wires as possible.

### 3. Operating modes

This chip has three operating modes. Each mode is selected by inputs to the MEAS pin and /SETUP pin.

- (1) Normal measurement mode ---- Mode to detect touch/no-touch. In this mode, one of the following modes can be selected according to the output signal form.
  - (1-1) On/off output mode ---- Out0-3 signals are used. Touch/no-touch detection results are output from the respective channels with low/high signal.
  - (1-2) Serial communication mode --- Measured results are transmitted in serial with a three-wire SPI function using SCK, SD and SCS signals.
- (2) Setup mode ---- Chip operation is set for serial communication in this mode.
- (3) Teaching mode ---- Teaching refers to the automatic setting of threshold values for touch and no-touch while somebody touches the sensor.

<i>/SETUP pin</i>	<i>MEAS pin</i>	<i>Operation mode</i>
High	High	Normal measurement mode
High	Low	Normal measurement mode (standby status without executing measurement)
Low	High	Teaching mode
Low	Low	Setup mode

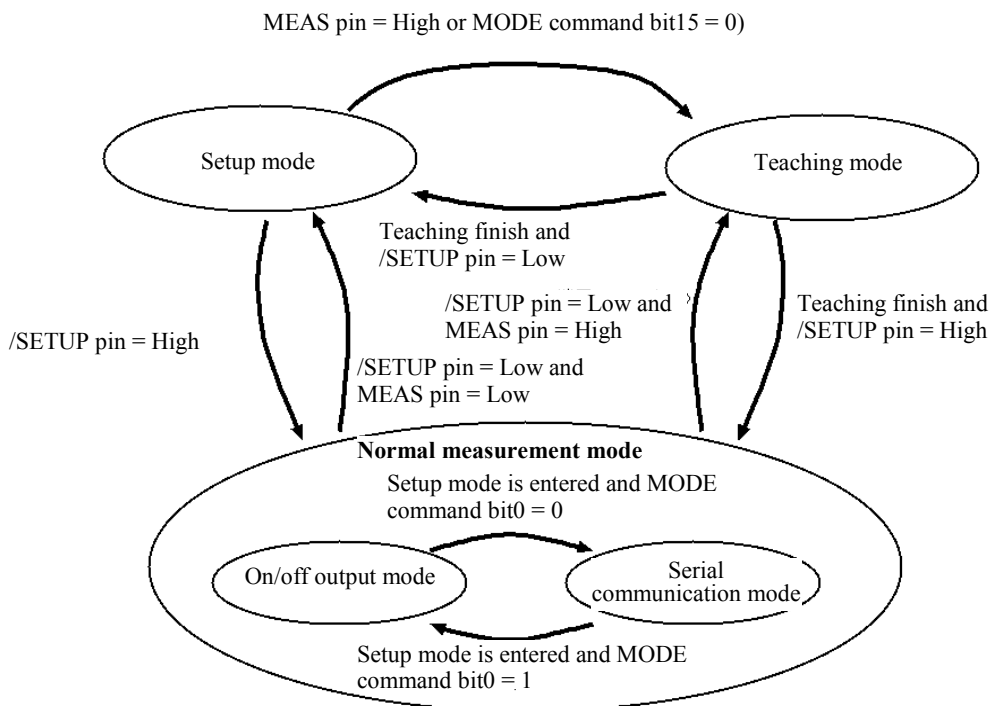

#### 4. Measurement

The chip measures the discharge of the charge stored in the charge capacitor. When a finger is placed close to the touch electrode, the electrostatic capacitance of the electrode increases and the discharge period for the charge becomes shorter. The chip has a built-in counter to measure the discharge period, and whether or not the sensor has been touched is judged according to whether the length of the discharge period exceeds a specified value or not. Hereafter, the length of the discharge period is referred to as the measured value.

With this chip, the measured value when the sensor is not touched (reference value), the amount of variation of the measured value which allows a judgment that the sensor is touched (amount judged on), and the amount of variation of the measured value when returning from on status (hysteresis) can be set for each channel respectively. The relationships between the measured value and the above values are as follows:

$[\text{Measured value}] < [\text{Reference value}] - [\text{Variation judged on}] \rightarrow$  Touch  
 $[\text{Measured value}] > [\text{Reference value}] - [\text{Variation judged on}] + [\text{Hysteresis}] \rightarrow$  Return from touch to no-touch

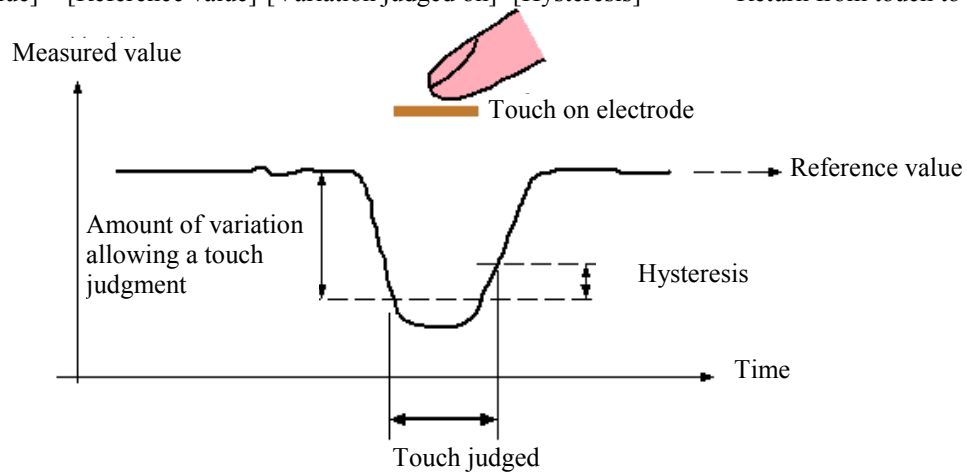

Even in the touched state, the measured value changes according to variation in the environment (output drift). The chip is provided with an automatic drift-correction function, which can cancel mild changes of the measured value due to variation in the environment (drift correction function). It is possible to select whether or not to execute drift correction in setup mode.

## 5. Serial communication

It is possible to read out measured values and set the operation mode by sending/receiving data to/from this chip through serial communication.

Serial communication is performed with an SPI-compliant method using SCK (transfer clock), MOSI (data reception (host→B6TS)) and MISO (data transmission (B6TS→host)).

The SPI communication method works as follows:

(Refer to “8. Electrical specifications” for specific communication timing, etc.)

- Operation in SPI slave mode  
Supply SCK (transfer clock) from outside.
- SCK (transfer clock) is set to high during idling. The data is latched at the rising edge of the clock.
- The data is MSB first.

This chip sends/receives data using 4 bytes, consisting of commands, dummy data, and data.

Command: 1 byte (MSB 1 bit is used for the read/write flag.)

Dummy data: 1 byte (ignored)

Data: 2 bytes

Read (data flow: B6TS→host)

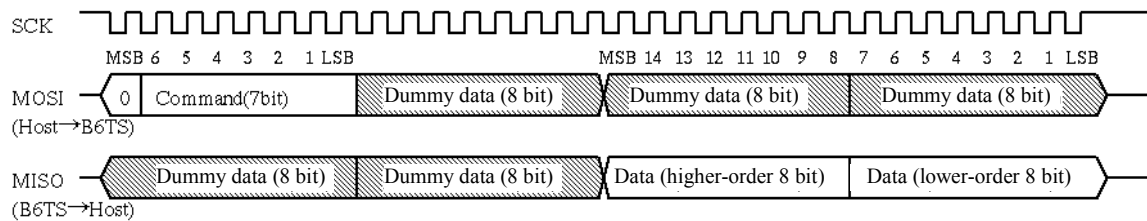

Write (data flow: host→B6TS)

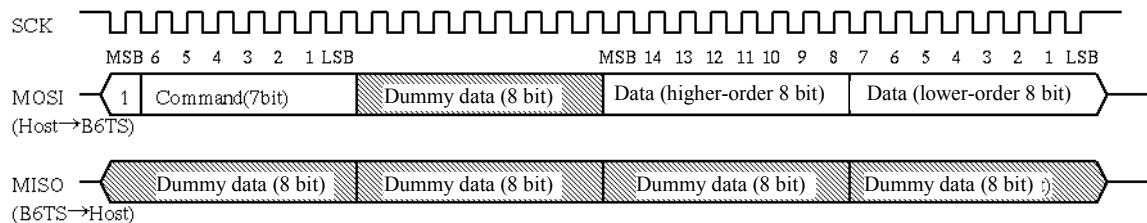

If data communication is performed during normal measurement mode, the measurement operation stops while the data is communicated.

After communication finishes, measurement restarts.

## 6. Commands

The commands and data used in serial communication are listed below:

The data comprises read only data (read) and read/write data (read/write). If serial communication is made to write read only data, the operation will be invalid.

Some of the data are not accessible in some operation modes. If inaccessible data are read out, the read data is indefinite. If inaccessible data are written, the data is ignored.

<i>Command code (Designation)</i>	<i>Main function</i>	<i>Read/write restriction</i>	<i>Access restriction</i>	
			Normal measurement mode (in serial communication mode)	Setup mode
0x00(ID)–0x25(CHYS7)	Measured data	Read only	Accessible	Accessible
0x39(CHEN) –0x67(RHYS7)	Parameter setting	Read/write	Inaccessible	

When writable data are written in this chip, the built-in register corresponding to each command is rewritten. Then, if the normal measurement mode is entered, the chip can be operated with the written parameters (mode, etc.). In this case, because only the built-in register is rewritten, the value in each register returns to its original value (value stored in EEPROM) when power is turned off and on again.

To store the built-in register value in EEPROM, an EEPROM write command must be received. When an EEPROM write command is received, the content of the register is stored in EEPROM.

### 6.1 List of commands

<i>Command code</i>	<i>Designation</i>	<i>Description</i>	<i>Access limit</i>			<i>Remark</i>
			Read (R) Write (W)	Normal measurement mode	Setup mode	
0x00	ID	Chip ID	R	○	○	
0x01	BDATA	Detected result of each channel	R	○	○	1 channel 1 bit
0x02	DCH0	Ch0 measured value	R	○	○	
0x03	DCH1	Ch1 measured value	R	○	○	
0x04	DCH2	Ch2 measured value	R	○	○	
0x05	DCH3	Ch3 measured value	R	○	○	
0x06	DCH4	Ch4 measured value	R	○	○	
0x07	DCH5	Ch5 measured value	R	○	○	
0x08	DCH6	Ch6 measured value	R	○	○	
0x09	DCH7	Ch7 measured value	R	○	○	
0x0A : 0x0D	(System reservation)					
0x0E	CREFO	Current Ch0 reference value	R	○	○	Result of drift correction is reflected.
0x0F	CTHR0	Current Ch0 variation judged as On	R	○	○	Result of drift correction is reflected.
0x10	CHYS0	Current Ch0 hysteresis value	R	○	○	Result of drift correction is reflected.
0x11	CREF1	Current Ch1 reference value	R	○	○	Result of drift correction is reflected.

<i>Command code</i>	<i>Designation</i>	<i>Description</i>	<i>Access limit</i>			<i>Remark</i>
			R	○	○	
0x12	CTHR1	Current Ch1 variation judged as On	R	○	○	Result of drift correction is reflected.
0x13	CHYS1	Current Ch1 hysteresis value	R	○	○	Result of drift correction is reflected.
0x14	CREF2	Current Ch2 reference value	R	○	○	Result of drift correction is reflected.
0x15	CTHR2	Current Ch2 variation judged as On	R	○	○	Result of drift correction is reflected.
0x16	CHYS2	Current Ch2 hysteresis value	R	○	○	Result of drift correction is reflected.
0x17	CREF3	Current Ch3 reference value	R	○	○	Result of drift correction is reflected.
0x18	CTHR3	Current Ch3 variation judged as On	R	○	○	Result of drift correction is reflected.
0x19	CHYS3	Current Ch3 hysteresis value	R	○	○	Result of drift correction is reflected.
0x1A	CREF4	Current Ch4 reference value	R	○	○	Result of drift correction is reflected.
0x1B	CTHR4	Current Ch4 variation judged as On	R	○	○	Result of drift correction is reflected.
0x1C	CHYS4	Current Ch4 hysteresis value	R	○	○	Result of drift correction is reflected.
0x1D	CREF5	Current Ch5 reference value	R	○	○	Result of drift correction is reflected.
0x1E	CTHR5	Current Ch5 variation judged as On	R	○	○	Result of drift correction is reflected.
0x1F	CHYS5	Current Ch5 hysteresis value	R	○	○	Result of drift correction is reflected.
0x20	CREF6	Current Ch6 reference value	R	○	○	Result of drift correction is reflected.
0x21	CTHR6	Current Ch6 variation judged as On	R	○	○	Result of drift correction is reflected.
0x22	CHYS6	Current Ch6 hysteresis value	R	○	○	Result of drift correction is reflected.
0x23	CREF7	Current Ch7 reference value	R	○	○	Result of drift correction is reflected.
0x24	CTHR7	Current Ch7 variation judged as On	R	○	○	Result of drift correction is reflected.
0x25	CHYS7	Current Ch7 hysteresis value	R	○	○	Result of drift correction is reflected.
0x26 : 0x38	(System reservation)					
0x39	CHEN	Channel measurement enable	R/W		○	
0x3A	TCAL	Teaching count number	R/W		○	
0x3B	TOG	Toggle action	R/W		○	
0x3C	ACD	Cumulative judgment count	R/W		○	
0x3D	SLP	Sleep time	R/W		○	
0x3E	MODE	Operation mode	R/W		○	
0x3F	ROMSTR	EEPROM write	R/W		○	Writing into ROM with dummy write
0x40	REF0	Ch0 reference value	R/W		○	
0x41	THR0	Ch0 variation judged as on	R/W		○	
0x42	HYS0	Ch0 hysteresis	R/W		○	
0x43	RTHR0	Ch0 On-judgment ratio	R/W		○	Used in teaching
0x44	RHYS0	Ch0 hysteresis ratio	R/W		○	Used in teaching
0x45	REF1	Ch1 reference value	R/W		○	
0x46	THR1	Ch1 variation judged as on	R/W		○	
0x47	HYS1	Ch1 hysteresis	R/W		○	
0x48	RTHR1	Ch1 On-judgment ratio	R/W		○	Used in teaching

<b>Command code</b>	<b>Designation</b>	<b>Description</b>	<b>Access limit</b>			<b>Remark</b>
0x49	RHYS1	Ch1 hysteresis ratio	R/W		○	Used in teaching
0x4A	REF2	Ch2 reference value	R/W		○	
0x4B	THR2	Ch2 variation judged as on	R/W		○	
0x4C	HYS2	Ch2 hysteresis	R/W		○	
0x4D	RTHR2	Ch2 On-judgment ratio	R/W		○	Used in teaching
0x4E	RHYS2	Ch2 hysteresis ratio	R/W		○	Used in teaching
0x4F	REF3	Ch3 reference value	R/W		○	
0x50	THR3	Ch3 variation judged as on	R/W		○	
0x51	HYS3	Ch3 hysteresis	R/W		○	
0x52	RTHR3	Ch3 On-judgment ratio	R/W		○	Used in teaching
0x53	RHYS3	Ch3 hysteresis ratio	R/W		○	Used in teaching
0x54	REF4	Ch4 reference value	R/W		○	
0x55	THR4	Ch4 variation judged as on	R/W		○	
0x56	HYS4	Ch4 hysteresis	R/W		○	
0x57	RTHR4	Ch4 On-judgment ratio	R/W		○	Used in teaching
0x58	RHYS4	Ch4 hysteresis ratio	R/W		○	Used in teaching
0x59	REF5	Ch5 reference value	R/W		○	
0x5A	THR5	Ch5 variation judged as on	R/W		○	
0x5B	HYS5	Ch5 hysteresis	R/W		○	
0x5C	RTHR5	Ch5 On-judgment ratio	R/W		○	Used in teaching
0x5D	RHYS5	Ch5 hysteresis ratio	R/W		○	Used in teaching
0x5E	REF6	Ch6 reference value	R/W		○	
0x5F	THR6	Ch6 variation judged as on	R/W		○	
0x60	HYS6	Ch6 hysteresis	R/W		○	
0x61	RTHR6	Ch6 On-judgment ratio	R/W		○	Used in teaching
0x62	RHYS6	Ch6 hysteresis ratio	R/W		○	Used in teaching
0x63	REF7	Ch7 reference value	R/W		○	
0x64	THR7	Ch7 variation judged as on	R/W		○	
0x65	HYS7	Ch7 hysteresis	R/W		○	
0x66	RTHR7	Ch7 On-judgment ratio	R/W		○	Used in teaching
0x67	RHYS7	Ch7 hysteresis ratio	R/W		○	Used in teaching
0x68 : 0x7F	(System reservation)					



## 6.2 Description of commands

### 6.2.1 ID: Chip ID (read only)

Used as ID of the chip. The data is fixed to 0x018.

<i>Command code</i>	15	14	13	12	11	10	9	8	7	6	5	4	3	2	1	0
0x00	0	0	0	0	0	0	0	1	1	0	0	0	0	0	0	1

### 6.2.2 BDATA: Detection result of touch/no-touch for each channel (read only)

Measured value for each channel is indicated by 1/0.

1: Off (no-touch), 0: On (touch)

<i>Command code</i>	15	14	13	12	11	10	9	8	7	6	5	4	3	2	1	0
0x01	1	1	1	1	1	1	1	1	Ch7	Ch6	Ch5	Ch4	Ch3	Ch2	Ch1	Ch0

### 6.2.3 DCHx: Measured value for each channel (read only)

Measured value for each channel is indicated by an unsigned 16-bit integer.

<i>Command code</i>	15	14	13	12	11	10	9	8	7	6	5	4	3	2	1	0
0x02..0x09	D15	D14	D13	D12	D11	D10	D9	D8	D7	D6	D5	D4	D3	D2	D1	D0

Channel 0 (DCH0) – Command code 0x02

Channel 1 (DCH1) – Command code 0x03

Channel 2 (DCH2) – Command code 0x04

Channel 3 (DCH3) – Command code 0x05

Channel 4 (DCH4) – Command code 0x06

Channel 5 (DCH5) – Command code 0x07

Channel 6 (DCH6) – Command code 0x08

Channel 7 (DCH7) – Command code 0x09

### 6.2.4 CREFx: Current reference value for each channel (read only)

Current reference value for each channel is indicated by an unsigned 16-bit integer.

<i>Command code</i>	15	14	13	12	11	10	9	8	7	6	5	4	3	2	1	0
0x0E..0x23	D15	D14	D13	D12	D11	D10	D9	D8	D7	D6	D5	D4	D3	D2	D1	D0

Channel 0 (CREF0) – Command code 0x0E

Channel 1 (CREF1) – Command code 0x11

Channel 2 (CREF2) – Command code 0x14

Channel 3 (CREF3) – Command code 0x17

Channel 4 (CREF4) – Command code 0x1A

Channel 5 (CREF5) – Command code 0x1D

Channel 6 (CREF6) – Command code 0x20

Channel 7 (CREF7) – Command code 0x23

6.2.5 CTHR<sub>x</sub>: Current variation for each channel judged as on (read only)

Current variation for each channel judged as on is indicated by an unsigned 16-bit integer.

<i>Command code</i>	15	14	13	12	11	10	9	8	7	6	5	4	3	2	1	0
0x0F..0x24	D15	D14	D13	D12	D11	D10	D9	D8	D7	D6	D5	D4	D3	D2	D1	D0

- Channel 0 (CTHR0)– Command code 0x0F
- Channel 1 (CTHR1) Command code 0x12
- Channel 2 (CTHR2) Command code 0x15
- Channel 3 (CTHR3) Command code 0x18
- Channel 4 (CTHR4)– Command code 0x1B
- Channel 5 (CTHR5) Command code 0x1E
- Channel 6 (CTHR6) Command code 0x21
- Channel 7 (CTHR7) Command code 0x24

6.2.6 CHYS<sub>x</sub>: Current hysteresis for each channel (read only)

Current hysteresis for each channel is indicated by an unsigned 16-bit integer.

<i>Command code</i>	15	14	13	12	11	10	9	8	7	6	5	4	3	2	1	0
0x10..0x25	D15	D14	D13	D12	D11	D10	D9	D8	D7	D6	D5	D4	D3	D2	D1	D0

- Channel 0 (CHYS0)– Command code 0x10
- Channel 1 (CHYS1) Command code 0x13
- Channel 2 (CHYS2) Command code 0x16
- Channel 3 (CHYS3) Command code 0x19
- Channel 4 (CHYS4)– Command code 0x1C
- Channel 5 (CHYS5) Command code 0x1F
- Channel 6 (CHYS6) Command code 0x22
- Channel 7 (CHYS7) Command code 0x25

6.2.7 CHEN: Measurement enable for each channel (read/write enabled only in setup mode)

Whether or not measurement is executed in each channel is set with 1/0.

1: measurement executed, 0: not executed

Only lower-order 4 bits are valid. If the other bits are written, they are ignored.

<i>Command code</i>	15	14	13	12	11	10	9	8	7	6	5	4	3	2	1	0
0x39	1	1	1	1	1	1	1	1	Ch7	Ch6	Ch5	Ch4	Ch3	Ch2	Ch1	Ch0

### 6.2.8 TCAL: Teaching measurement count (read/write enabled only in setup mode)

Sets the measurement count when teaching.

Teaching measurement is executed 32 times the value of TCAL. The teaching operation must be performed during this period (each electrode must be touched three times or more).

Reference value (REFx), quantity of variation judged as on (THR<sub>x</sub>), and hysteresis (HYS<sub>x</sub>) are changed by teaching.

When TCAL is set to "0", only the reference value (THR<sub>x</sub>) is changed in teaching.

Only lower-order 8 bits are valid. If the other bits are written, they are ignored.

<i>Command code</i>	15	14	13	12	11	10	9	8	7	6	5	4	3	2	1	0
0x3A	1	1	1	1	1	1	1	1	D7	D6	D5	D4	D3	D2	D1	D0

### 6.2.9 TOG: Toggle action (read/write enabled only in setup mode)

Sets whether or not to make each channel perform toggle action. This setting takes effect on the signals output from OUT0-3 and BDATA command data.

1: Toggle mode off (momentary action: turned on only with a touch)

0: Toggle mode on (alternate action: turned on with a touch and off with the next touch)

Only lower-order 4 bits are valid. If the other bits are written, they are ignored.

<i>Command code</i>	15	14	13	12	11	10	9	8	7	6	5	4	3	2	1	0
0x3B	1	1	1	1	1	1	1	1	Ch7	Ch6	Ch5	Ch4	Ch3	Ch2	Ch1	Ch0

### 6.2.10 ACD: Cumulative judgment count (read/write enabled only in setup mode)

Only after consecutive measurement ACD value + one times, a touch (or no-touch) is judged and this output is varied. This output takes effect on the signals output from OUT0 - 3 and BDATA command data.

For example, with ACD = 2, only after three consecutive measurements are judged as a touch (or no-touch), does this output signal turn on (or off).

Only lower-order 8 bits are valid. If the other bits are written, they are ignored.

<i>Command code</i>	15	14	13	12	11	10	9	8	7	6	5	4	3	2	1	0
0x3C	1	1	1	1	1	1	1	1	D7	D6	D5	D4	D3	D2	D1	D0

### 6.2.11 SLP: Sleep time (read/write enabled only in setup mode)

Sets the standby time between one measurement and the next measurement (sleep time).

Sleep continues for SOP value × 10mS (typ)

When SLP is set to "0", measurements are made consecutively without sleep time.

Only lower-order 8 bits are valid. If the other bits are written, they are ignored.

<i>Command code</i>	15	14	13	12	11	10	9	8	7	6	5	4	3	2	1	0
0x3D	1	1	1	1	1	1	1	1	D7	D6	D5	D4	D3	D2	D1	D0

6.2.12 MODE: Operation mode (read/write enabled only in setup mode)

Sets various modes.

Only the bits described are valid.

If the other bits are written, they are ignored.

Command code	15	14	13	12	11	10	9	8	7	6	5	4	3	2	1	0
0x3E	TS	TER	1	1	1	1	1	1	1	1	1	1	1	DC	CHG	CON

TS: Teaching start

Teaching mode is entered when “0” is written in this bit.

(During read out this bit is always “1”)

TER: Teaching error flag

Set/reset according to result of teaching.

Set to “1” when teaching finishes normally.

If a teaching error occurs, this bit is set to “0”.

This flag is not cleared automatically. To clear this flag, write “1” to this bit.

DC: Drift correction

Sets whether or not to execute drift correction.

1: Drift correction executed, 2: Not executed

CHG: CHG pin function

The signal is specified from the CHG pin in normal measurement mode (serial communication mode). With this pin set to “1”, when on/off changes in any channel (when any channel is touched (comes on) or changes from touch to no-touch (goes off)), the signal is high.

When this pin is set to “0”, the signal is high every time a measurement finishes.

CON: Output setting

Sets output mode in normal measurement mode.

When set to “1”, on/off output mode is entered.

When set to “0”, serial communication mode is entered.

6.2.13 ROMSTR: EEPROM write (only write is enabled in setup mode)

When this command is issued by setting the data to 0x5354, all the parameter data are written in the EEPROM built in this chip.

When the data is other than 0x5354, this command is ignored.

Until this command is issued, received write data are stored in volatile memory.

While data is being written in EEPROM, the CHG pin is low.

Also, during the write, inputs to the /SETUP and MEAS pins are ignored. Accordingly, it is not possible to change the operation mode.

Command code	15	14	13	12	11	10	9	8	7	6	5	4	3	2	1	0
0x3F	0	1	0	1	0	0	1	1	0	1	0	1	0	1	0	0

6.2.14 REF<sub>x</sub>: Reference value for each channel (read/write enabled only in setup mode)

The reference value for each channel can be set with an unsigned 16-bit integer.

Users can alter this setting (in setup mode), or rewrite it by teaching. It cannot be changed by drift correction or the like.

<i>Command code</i>	15	14	13	12	11	10	9	8	7	6	5	4	3	2	1	0
0x40..0x63	D15	D14	D13	D12	D11	D10	D9	D8	D7	D6	D5	D4	D3	D2	D1	D0

- Channel 0 (REF0) – Command code 0x40
- Channel 1 (REF1) – Command code 0x45
- Channel 2 (REF2) – Command code 0x4A
- Channel 3 (REF3) – Command code 0x4F
- Channel 4 (REF4) – Command code 0x54
- Channel 5 (REF5) – Command code 0x59
- Channel 6 (REF6) – Command code 0x5E
- Channel 7 (REF7) – Command code 0x63

6.2.15 THR<sub>x</sub>: Quantity of variation judged as on for each channel (read/write enabled only in setup mode)

Quantity of variation judged as on for each channel can be set with an unsigned 16-bit integer.

Users can alter this setting (in setup mode) or rewrite it by teaching. It cannot be changed by drift correction or the like.

<i>Command code</i>	15	14	13	12	11	10	9	8	7	6	5	4	3	2	1	0
0x41..0x64	D15	D14	D13	D12	D11	D10	D9	D8	D7	D6	D5	D4	D3	D2	D1	D0

- Channel 0 (THR0) – Command code 0x41
- Channel 1 (THR1) – Command code 0x46
- Channel 2 (THR2) – Command code 0x4B
- Channel 3 (THR3) – Command code 0x50
- Channel 4 (THR4) – Command code 0x55
- Channel 5 (THR5) – Command code 0x5A
- Channel 6 (THR6) – Command code 0x5F
- Channel 7 (THR7) – Command code 0x64

6.2.16 HYS<sub>x</sub>: Hysteresis for each channel (read/write enabled only in setup mode)

Hysteresis for each channel can be set with an unsigned 16-bit integer.

Users can alter this setting (in setup mode) or rewrite it by teaching. It cannot be changed by drift correction or the like.

<i>Command code</i>	15	14	13	12	11	10	9	8	7	6	5	4	3	2	1	0
0x42..0x65	D15	D14	D13	D12	D11	D10	D9	D8	D7	D6	D5	D4	D3	D2	D1	D0

- Channel 0 (HYS0) – Command code 0x42
- Channel 1 (HYS1) – Command code 0x47
- Channel 2 (HYS2) – Command code 0x4C
- Channel 3 (HYS3) – Command code 0x51
- Channel 4 (HYS4) – Command code 0x56
- Channel 5 (HYS5) – Command code 0x5B
- Channel 6 (HYS6) – Command code 0x60
- Channel 7 (HYS7) – Command code 0x65

6.2.17 RTHR<sub>x</sub>: On-judgment ratio for each channel (read/write enabled only in setup mode)

Used in teaching.

Sets the ratio of the quantity of variation judged as on (THR<sub>x</sub>) to the measured value observed in teaching with an unsigned 4-bit integer. (Refer to “7. Teaching” for details)

Only the lower-order 4 bits are valid. If the other bits are written to, they are ignored.

If the measured value changes by  $\Delta A$  due to a touch during teaching, the quantity of variation judged as on that is newly set in teaching (THR<sub>x</sub>) is calculated as:

$$\text{Quantity of variation judged as on (THR}_x) = \Delta A \times (\text{on-judgment ratio (RTHR}_x) + 1) / 16$$

For example, if RTHR<sub>x</sub> = 10, the quantity of variation judged as on (THR<sub>x</sub>) is:

$$\text{THR}_x = \Delta A \times (10 + 1) / 16 = \Delta A \times 0.69 \text{ (about 70\% of } \Delta A)$$

Command code	15	14	13	12	11	10	9	8	7	6	5	4	3	2	1	0
0x43..0x66	1	1	1	1	1	1	1	1	1	1	1	1	D3	D2	D1	D0

Channel 0 (RTHR0)– Command code 0x43

Channel 1 (RTHR1) Command code 0x48

Channel 2 (RTHR2) Command code 0x4D

Channel 3 (RTHR3) Command code 0x52

Channel 4 (RTHR4)– Command code 0x57

Channel 5 (RTHR5) Command code 0x5C

Channel 6 (RTHR6) Command code 0x61

Channel 7 (RTHR7) Command code 0x66

6.2.17 RHYS<sub>x</sub>: Hysteresis ratio for each channel (read/write enabled only in setup mode)

Used in teaching.

Sets the ratio of hysteresis (HYS<sub>x</sub>) to the measured value observed in teaching with an unsigned 4-bit integer. (Refer to “7. Teaching” for details.)

Only the lower-order 4 bits are valid. If the other bits are written to, they are ignored.

If the measured value changes by  $\Delta A$  due to a touch during teaching, the new hysteresis that is set in teaching (HYS<sub>x</sub>) is calculated as:

$$\text{Hysteresis (HYS}_x) = \Delta A \times (\text{Hysteresis ratio (RHYS}_x) / 16$$

For example, if RHYS<sub>x</sub> = 2, hysteresis (HYS<sub>x</sub>) is:

$$\text{HYS}_x = \Delta A \times 2 / 16 = \Delta A \times 0.13 \text{ (about 13\% of } \Delta A)$$

Command code	15	14	13	12	11	10	9	8	7	6	5	4	3	2	1	0
0x44..0x67	1	1	1	1	1	1	1	1	1	1	1	1	D3	D2	D1	D0

Channel 0 (RHYS0)– Command code 0x43

Channel 1 (RHYS1) Command code 0x49

Channel 2 (RHYS2) Command code 0x4E

Channel 3 (RHYS3) Command code 0x53

Channel 4 (RHYS4)– Command code 0x58

Channel 5 (RHYS5) Command code 0x5D

Channel 6 (RHYS6) Command code 0x62

Channel 7 (RHYS7) Command code 0x67

## 7. Teaching

### 7.1 Outline of teaching

Such parameters as the quantity of variation judged as on can be set automatically through actual touches on the electrode. This operation is called “Teaching”.

When teaching, the reference value (REFx), quantity of variation judged as on (THR<sub>x</sub>) and hysteresis (HYS<sub>x</sub>) are updated appropriately, and stored in the EEPROM built into the chip.

Before performing a teaching operation, some preparation is required.  
The processing flow is as follows:

During teaching, serial communication is not available.  
However, checking the CHG pin allows status to be checked.

Once teaching mode is entered, any input other than /RESET is invalid until the measurement finishes and the chip comes out of teaching mode. Be aware that serial communication cannot be performed concurrently.

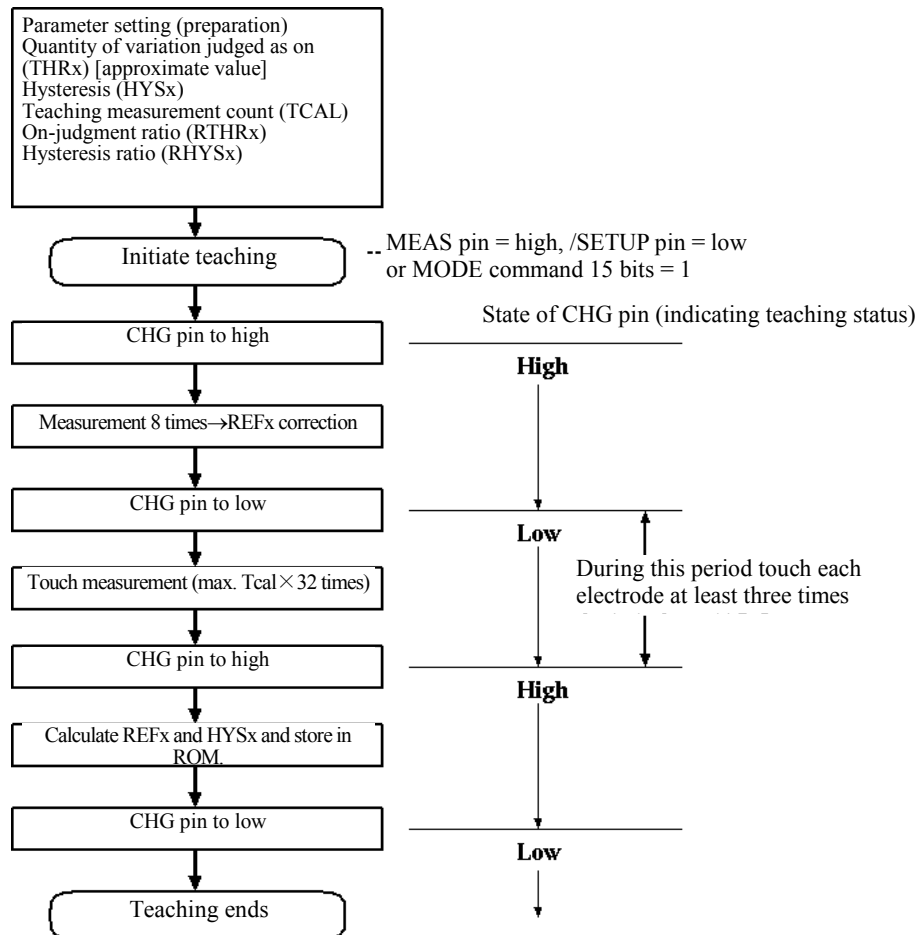

## 7.2 Preparation for teaching

To perform teaching, this chip must be brought into setup mode and some parameters must be set. The parameters (commands) associated with teaching are as follows:

### 7.2.1 Teaching measurement count (Refer to “6.2.8 TCAL: Teaching measurement count”)

During teaching, measurement is executed x number of times where x is the value of this parameter  $\times 32$ . (Hereafter, this is referred to as the teaching measurement count)

It takes 30–100 msec for one teaching measurement (depending on external circuit constants), and if this parameter is set to 10, the touches must be executed within 10-30 seconds.

Unless each electrode is touched three times within the number of teaching measurements after starting teaching, the teaching is regarded as faulty, and none of the parameters are updated.

However, when this parameter is set to “0”, only the reference value (REFx) is updated. In this case, no touching is required, and the teaching is not regarded as faulty even if no touches are executed.

### 7.2.2 Quantity of variation judged as on (Refer to “6.2.15 THR<sub>x</sub>: Quantity of variation judged as on”.)

This parameter contains the quantity of variation of the measured value that will allow judgment of a touch (approximate value).

To distinguish between variation of the measured value caused by a noise or the like and variation caused by touching during teaching, this parameter must be set to an approximate value.

If variation of half of this set value occurs during teaching, the electrode is judged touched. Therefore, an approximate value for variation likely to have been caused by touch may be entered.

### 7.2.3 Hysteresis (Refer to “6.2.16 HYS<sub>x</sub>: Hysteresis of each channel”.)

This parameter sets the hysteresis value in teaching (approximate value).

### 7.2.4 On-judgment ratio (Refer to “6.2.17 RTHR<sub>x</sub>: On-judgment ratio for each channel”) &

Hysteresis ratio (Refer to “6.2.17 RHYS<sub>x</sub>: Hysteresis ratio for each channel”)

These parameters set the ratios of the quantity of variation judged as on (THR<sub>x</sub>) and hysteresis (HYS<sub>x</sub>) to the variation of the measured value caused by touch.

During teaching, each electrode must be touched three times or more. Then, the minimum value of the quantity of variation caused by touch is calculated for each electrode of the chip. (Minimum value of quantity of variation)

The new quantity of variation judged as on and the new hysteresis are calculated using the minimum value of quantity of variation  $\Delta A$  as:

$$\text{Quantity of variation judged as on (THR}_x\text{)} = \Delta A \times (\text{On-judgment ratio (RTHR}_x\text{)} + 1) / 16$$

$$\text{Hysteresis (HYS}_x\text{)} = \Delta A \times (\text{Hysteresis ratio (RHYS}_x\text{)}) / 16$$

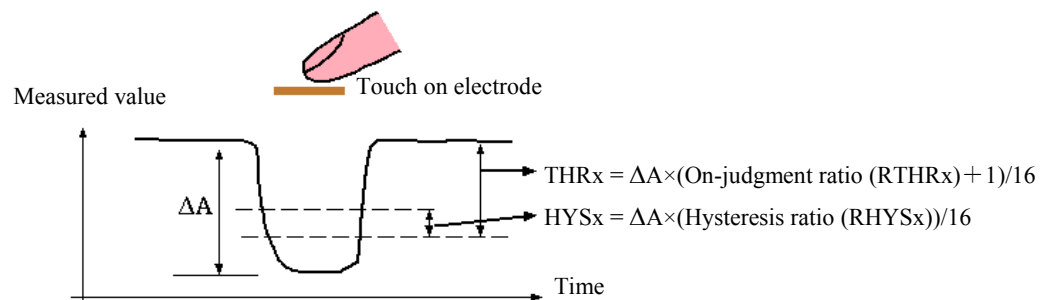



### 7.3 Performing teaching

There are two ways to enter teaching mode:

- (1) /SETUP pin = low, and MEAS pin = high
- (2) Write "0" into bit15 (TS) using the MODE command in setup mode.

When entering teaching mode by method (1), set the /SETUP pin to high or the MEAS pin to low before teaching finishes. If /SETUP pin = high and the MEAS pin = low, teaching will commence again.

When entering teaching mode, the CHG pin changes to high, indicating entry to teaching mode.

Just after teaching has started, the chip calibrates the reference value (REFx) (the measured value with no-touch). The measurement is performed eight times for each electrode, and the average of the eight measured values is taken as REFx. After the calibration finishes, the CHG pin output changes to low. Do not touch the touch electrode until the CHG pin changes to low.

After REFx has been calibrated, the chip starts the teaching measurement count ((TCAL) × 32 times). During this period, touch each electrode three times or more. The order for touching each of the electrodes is not defined. After the specified number of teaching measurements have finished, the CHG pin changes to high.

However, if the number of touches (the number of times the chip recognizes a touch) reaches 32, the chip finishes measuring and changes the CHG pin to high, even if the teaching measurement count has not been reached.

When touching the electrodes, do not touch two or more electrodes at the same time. If you do, teaching cannot be performed correctly. If more than one electrode is touched simultaneously in error, touch each of the electrodes touched simultaneously again. Touch all of the electrodes three times or more within the teaching measurement time.

After the touch measurements have finished, the chip updates the quantity of variation judged as on (THR<sub>x</sub>), and hysteresis (HYS<sub>x</sub>) according to the calculation formula described in "7.2.4 On-judgment ratio and hysteresis ratio" (updates the values stored in the built-in ROM). After the values are updated, the CHG pin changes to low and teaching finishes.

### 7.4 Checking the result of teaching

When teaching finishes correctly, bit14 (TER bit) of the data, which can be read with the MODE command, changes to "1". If teaching is not completed normally because the specified number of touches are not executed within the teaching measurement time or for some other reason, the TER bit changes to "0" and the quantity of variation judged as on (THR<sub>x</sub>) and hysteresis (HYS<sub>x</sub>) are not updated. (In this event, only the reference value (REFx) is updated.)

To reset the TER bit, set it to "1" using the MODE command, or perform teaching again (and finish the teaching operation normally).

## 8. Electrical characteristics

### 8.1 Absolute maximum ratings

Designation	Item	Condition	Rated value	Unit
V <sub>dd</sub>	Supply voltage		-0.3 – 6.5	V
V <sub>I</sub>	Input voltage		-0.3 – V <sub>dd</sub> +0.3	V
V <sub>O</sub>	Output voltage		-0.3 – V <sub>dd</sub> +0.3	V
P <sub>d</sub>	Power dissipation	T <sub>opr</sub> =25°C	300	mW
T <sub>opr</sub>	Ambient operating temperature		-20 – 85	°C
T <sub>stg</sub>	Storage temperature		-65 – 150	°C

### 8.2 Recommended operating conditions

Designation	Item	Condition	Rated value			Unit
			Minimum	Standard	Maximum	
V <sub>dd</sub>	Supply voltage		4.5		5.5	V
V <sub>IH</sub>	High input voltage		0.8V <sub>dd</sub>		V <sub>dd</sub>	V
V <sub>IL</sub>	Low input voltage		0		0.2V <sub>dd</sub>	V
I <sub>OH</sub>	High output voltage				-5	mA
I <sub>OL</sub>	Low output voltage				5	mA

Note 1: Unless otherwise specified, V<sub>dd</sub> = 4.5-5.5V, Topr = -20-85°C

### 8.3 Electrical characteristics

Designation	Item	Condition	Rated value			Unit
			Minimum	Standard	Maximum	
V <sub>OH</sub>	High Output voltage	I <sub>OH</sub> =-5mA	V <sub>dd</sub> -2.0		V <sub>dd</sub>	V
V <sub>OL</sub>	Low Output voltage	I <sub>OL</sub> =5mA			2.0	V
I <sub>IH</sub>	High Input voltage	V <sub>I</sub> =5V			5	μA
I <sub>IL</sub>	Low Input voltage	V <sub>I</sub> =0V			-5	μA
I <sub>CC</sub>	Supply voltage	Normal measurement mode		4		mA
-	Number of times of EEPROM write	T <sub>OPR</sub> =0-60°C	10000			Times
-	EEPROM write time	V <sub>dd</sub> =5V, T <sub>OPR</sub> =25°C (Note 2)		0.3		S
-	EEPROM data retention period	T <sub>OPR</sub> =55°C	20			Years

Note 1: Unless otherwise specified, V<sub>dd</sub> = 4.5-5.5V, Topr = -20-85°C

Note 2: The period following receipt of the EEPROM write command in setup mode until the data write finishes.

### 8.4 Necessary timing conditions

Designation	Item	Condition	Rated value		Unit
			Minimum	Maximum	
t <sub>c</sub> (SCK)	Serial communication clock cycle time		8650		nS
t <sub>w</sub> (SCKH)	Serial communication clock high pulse width		100		nS
t <sub>w</sub> (SCKL)	Serial communication clock low pulse width		100		nS
t <sub>d</sub> (SO)	Serial communication output delay time			80	nS
t <sub>h</sub> (SO)	Serial communication output hold time		0		nS
T <sub>su</sub> (SI)	Serial communication input setup time		35		nS
t <sub>h</sub> (SI)	Serial communication input hold time		90		nS
t <sub>w</sub> (BD)	Serial communication byte to byte interval		70		μS
t <sub>w</sub> (CD)	Serial communication command reception interval		265		μS
T <sub>w</sub> (CHG)	CHG pulse width	(Note 2)	85		μS
T <sub>su</sub> (SETUP)	Mode shift delay time	(Note 3)		150	μS
T <sub>w</sub> (RESET)	Reset pulse width		500		μS

Note 1: Unless otherwise specified, V<sub>dd</sub> = 4.5-5.5V, Topr = -20-85°C.

Note 2: This is the time period when the condition that CHG pulse width is at its minimum in the serial communication mode of normal measurement mode is set.

(CHG pin function is set to output at the end of every measurement [CHG bit = 0 with MODE command]) and the sleep time is set to zero [SLP command value = 0]).

Note 3: The delay time for the mode shift between normal measurement mode and setup mode.

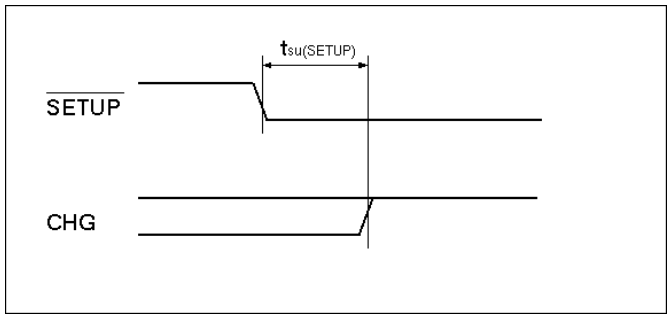
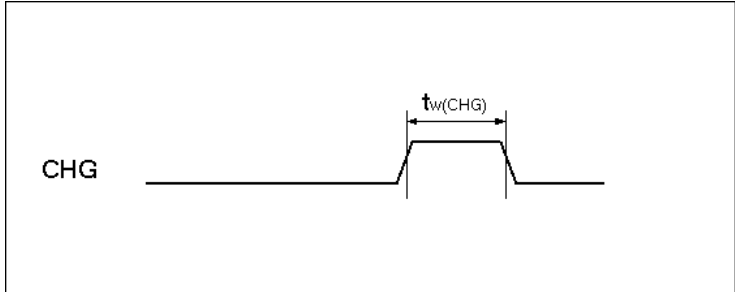
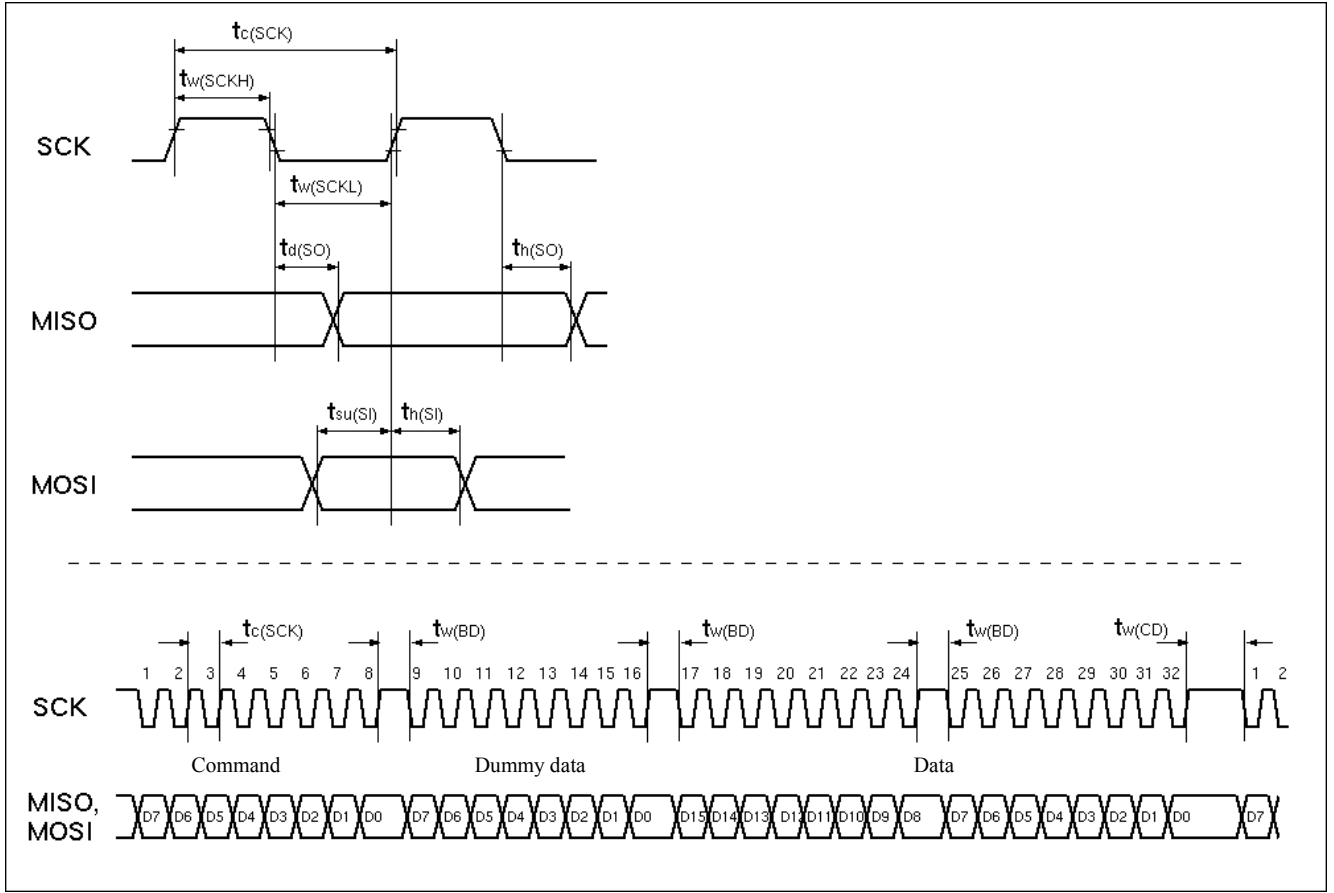

## 8.5 Measurement characteristics (typical example)

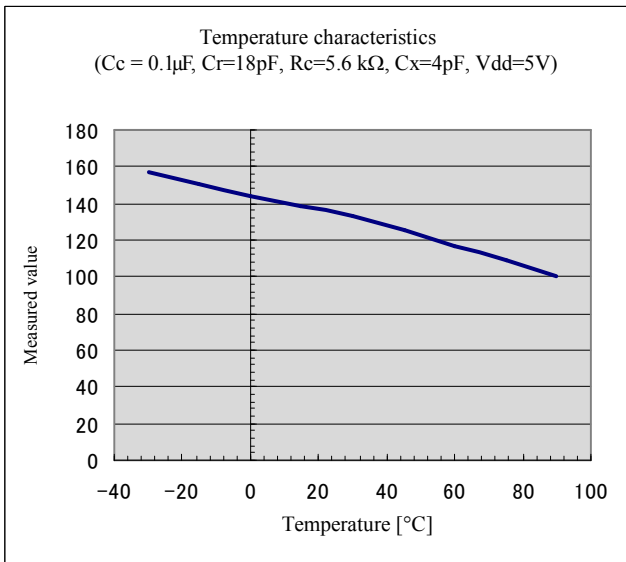
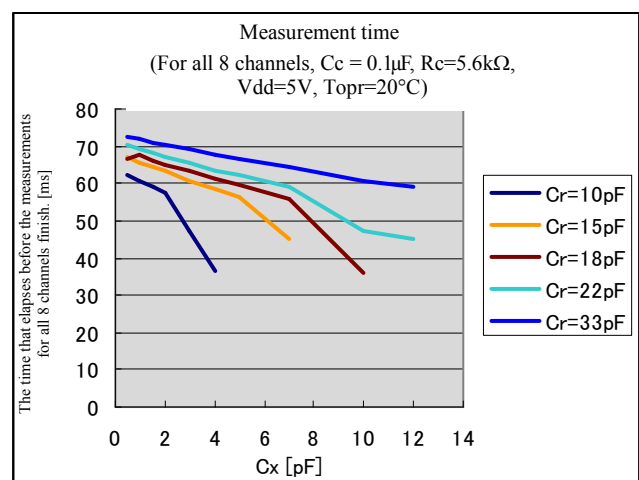
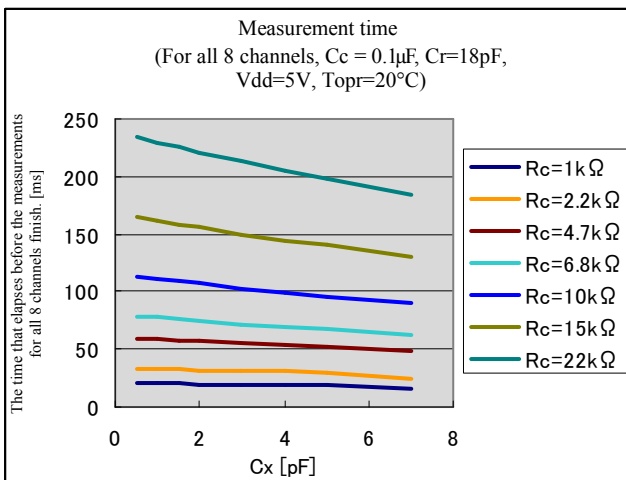
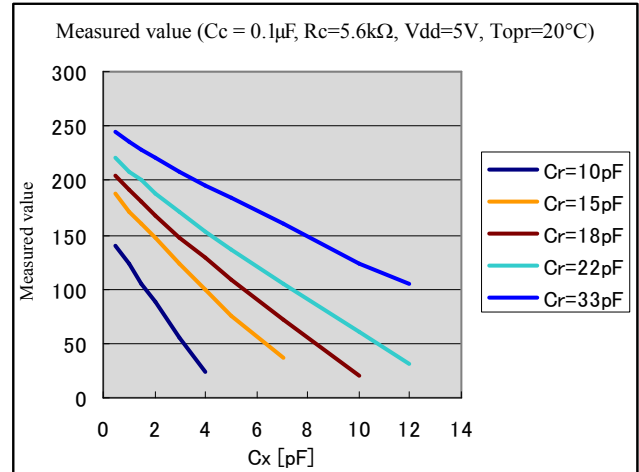
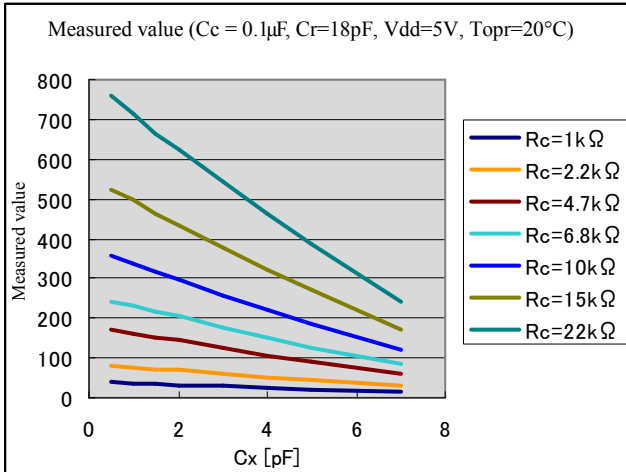

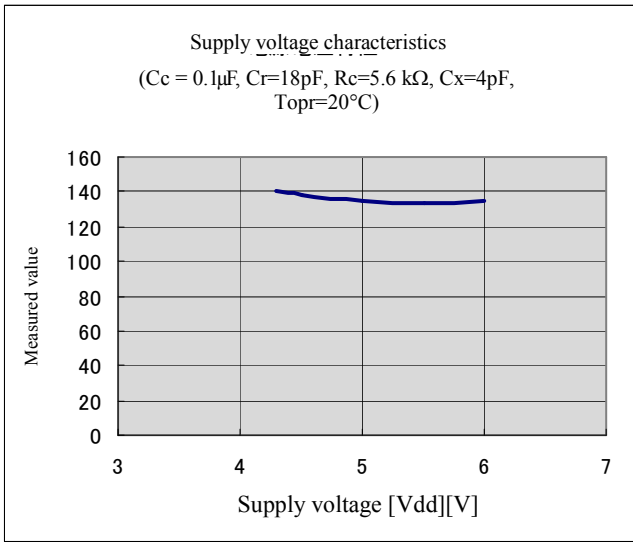

**9. Appearance and dimensions**

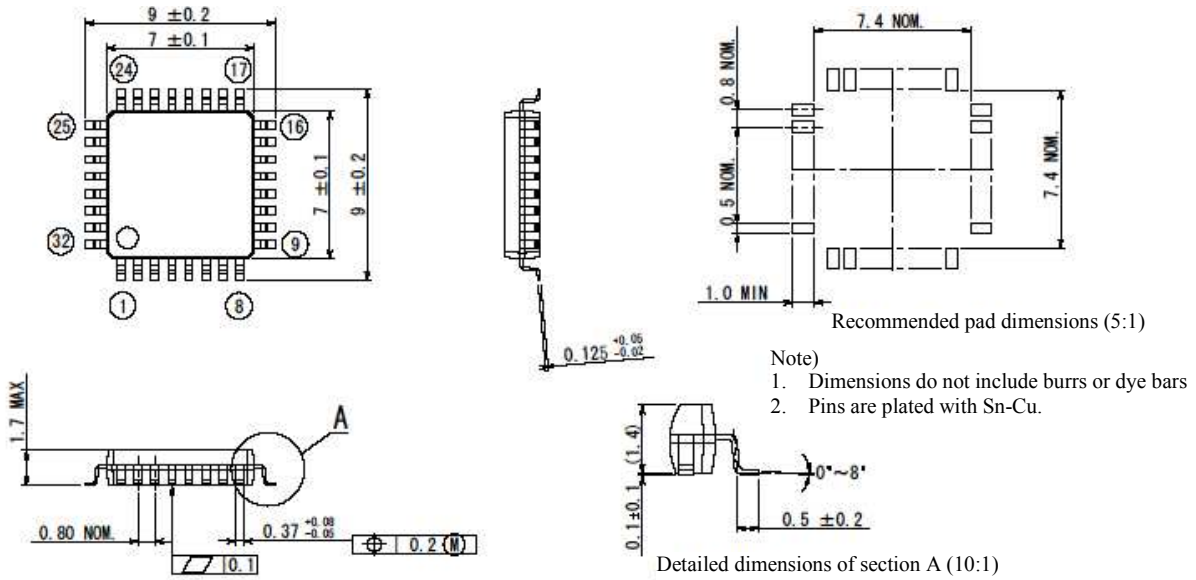

# Warranty Details

## 1. Warranty period

The warranty period for an Omron product is one year from purchase or delivery to a customer-specified place.

## 2. Scope of warranty

If any Omron product fails under Omron liability within the above warranty period, Omron shall supply a replacement or repair the product free of charge at the place of purchase. However, if the reason for the product failure falls into any of the following categories, the warranty will not apply:

- a) The product has been used or handled under conditions or in an environment not listed in the product's specifications, catalog, or operation manual (hereinafter referred to as the "catalog and the like").
- b) The failure has been caused by a non-Omron product.
- c) The product has been modified or repaired by somebody or corporation other than Omron.
- d) The product has been used for other than its intended use.
- e) The failure could not have been predicted based on the level of science or technology at the time of shipment.
- f) The failure has been caused by a natural or other disaster, an accident or the like that is not Omron's liability.

This warranty applies only to the Omron product itself, and any damage induced by a failed Omron product is excluded from this warranty.

## 3. Scope of service

The price of an Omron product does not include service expenses such as the cost of sending out technicians. If you wish to request non-inclusive services, please consult Omron sales personnel.

## 4. Scope of application

The above apply only to business and usage in Japan.

Please consult Omron sales personnel about business and usage in other countries.