



Model MB150 Mother-Baby Scale User Manual



8535-M212-O1 Rev B
03/15

CARDINAL SCALE MFG. CO.
PO BOX 151 • WEBB CITY, MO 64870
PH (417) 673-4631 • FAX (417) 673-5001
www.detectoscale.com

Technical Support: Ph: 866-254-8261 • techsupport@cardet.com

TABLE OF CONTENTS

INTRODUCTION	1
SPECIFICATIONS	1
BABY TRAY INSTALLATION	2
AC POWER ADAPTOR	4
INSTALLING/REPLACING THE BATTERY	5
KEY FUNCTIONS	6
DISPLAY ANNUNCIATORS	7
LEVEL INDICATOR	7
WEIGHT UNIT SWITCH	7
HOW TO USE BMI FEATURE	8
SETTING THE AUTO-OFF TIME	8
ERROR MESSAGES	9

FCC COMPLIANCE STATEMENT

WARNING! This equipment generates uses and can radiate radio frequency and if not installed and used in accordance with the instruction manual, may cause interference to radio communications. It has been tested and found to comply with the limits for a Class A computing device pursuant to Subpart J of Part 15 of FCC rules, which are designed to provide reasonable protection against such interference when operated in a commercial environment. Operation of this equipment in a residential area may cause interference in which case the user will be responsible to take whatever measures necessary to correct the interference.

You may find the booklet "How to Identify and Resolve Radio TV Interference Problems" prepared by the Federal Communications Commission helpful. It is available from the U.S. Government Printing Office, Washington, D.C. 20402. Request stock No. 001-000-00315-4.

PROPER DISPOSAL

When this device reaches the end of its useful life, it must be properly disposed of. It must not be disposed of as unsorted municipal waste. Within the European Union, this device should be returned to the distributor from where it was purchased for proper disposal. This is in accordance with EU Directive 2002/96/EC. Within North America, the device should be disposed of in accordance with the local laws regarding the disposal of waste electrical and electronic equipment.



It is everyone's responsibility to help maintain the environment and to reduce the effects of hazardous substances contained in electrical and electronic equipment on human health. Please do your part by making certain that this device is properly disposed of. The symbol shown to the right indicates that this device must not be disposed of in unsorted municipal waste programs.



All rights reserved. Reproduction or use, without expressed written permission, of editorial or pictorial content, in any manner, is prohibited. No patent liability is assumed with respect to the use of the information contained herein. While every precaution has been taken in the preparation of this manual, the Seller assumes no responsibility for errors or omissions. Neither is any liability assumed for damages resulting from use of the information contained herein. All instructions and diagrams have been checked for accuracy and ease of application; however, success and safety in working with tools depend to a great extent upon the individual accuracy, skill and caution. For this reason the Seller is not able to guarantee the result of any procedure contained herein. Nor can they assume responsibility for any damage to property or injury to persons occasioned from the procedures. Persons engaging the procedures do so entirely at their own risk.

Serial Number _____
Date of Purchase _____
Purchased From _____

RETAIN THIS INFORMATION FOR FUTURE USE

PRECAUTIONS	
Before using this indicator, read this manual and pay special attention to all "WARNING" symbols:	
	
IMPORTANT	ELECTRICAL WARNING

INTRODUCTION

The Model MB150 Mother-Baby Scale is a dual purpose battery-operated scale. The scale has two modes of operation. One mode will weight and compute the BMI (Body Mass Index) of an adult up to 330lb (150kg). The second mode will weight a baby up to 44lb (20kg). The scale is also equipped with a removable baby tray to allow weighing small children.

The scale can be used in a fixed location with the included 15VDC AC Power Adapter or it can be used as a portable scale with six "AA" batteries (not included).

This manual contains information on the operation of this scale. Please read it before attempting to use the scale and keep it handy for future reference.

SPECIFICATIONS

Capacity/Division:	Adult: 330lb x 0.2lb (150kg x 0.1kg) Baby: 44lb x 0.02lb (20kg x 0.01kg)
Tray:	Removable to allow scale to weigh small children
Weight Units:	lb/kg
Function Keys:	Adult: On/Off, Hold/BMI, Tare Baby: On/Off, Hold, Tare
Stabilization Time:	1 to 2 Seconds
Operating Temperature:	32° to 104°F (0° to 40°C)
Display:	1.0" (25 mm) LCD display with 5 active digits
Power Requirements:	15VDC @ 300mA AC Power Adapter (included) or Six "AA" alkaline batteries (not included)
Dimensions:	
Tray:	23" L x 11" W x 4 3/4" H (585 x 280 x 120 mm)
Scale:	13 3/8" L x 13" W x 2" H / (340 x 330 x 50 mm)

BABY TRAY INSTALLATION

1. Install tray from the rear of scale, sliding it to the front of scale (toward the display). Note that arrow on tray should point to front of scale.

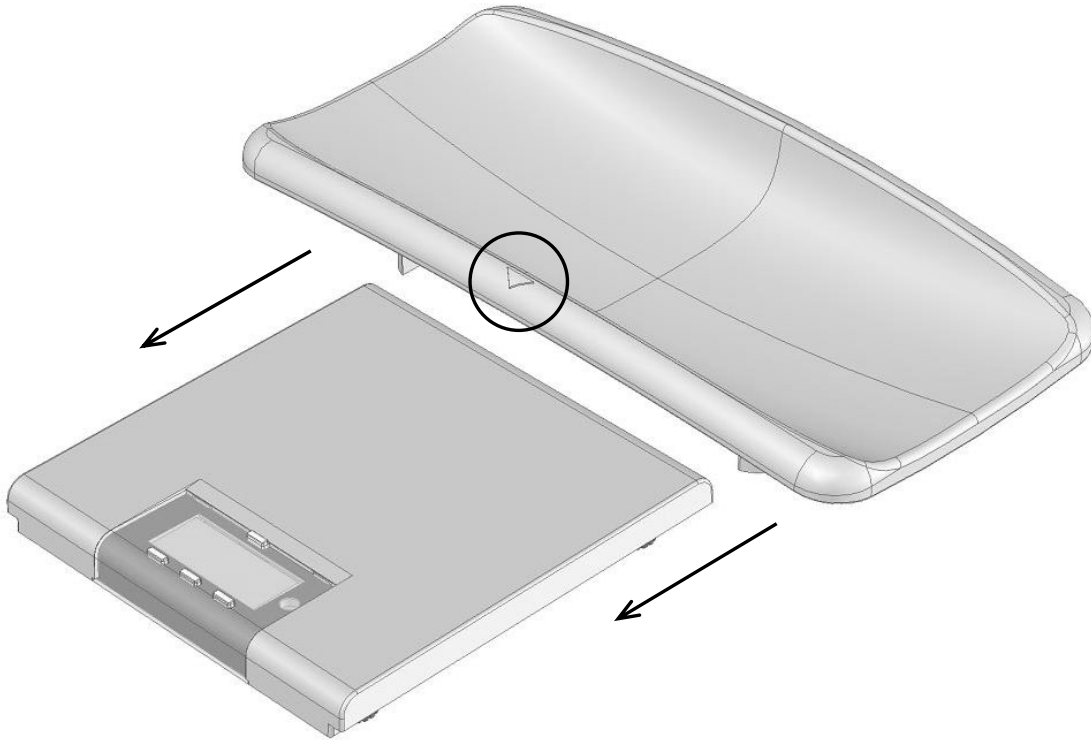

1. Turn scale upside down to screw tray and platform together properly.

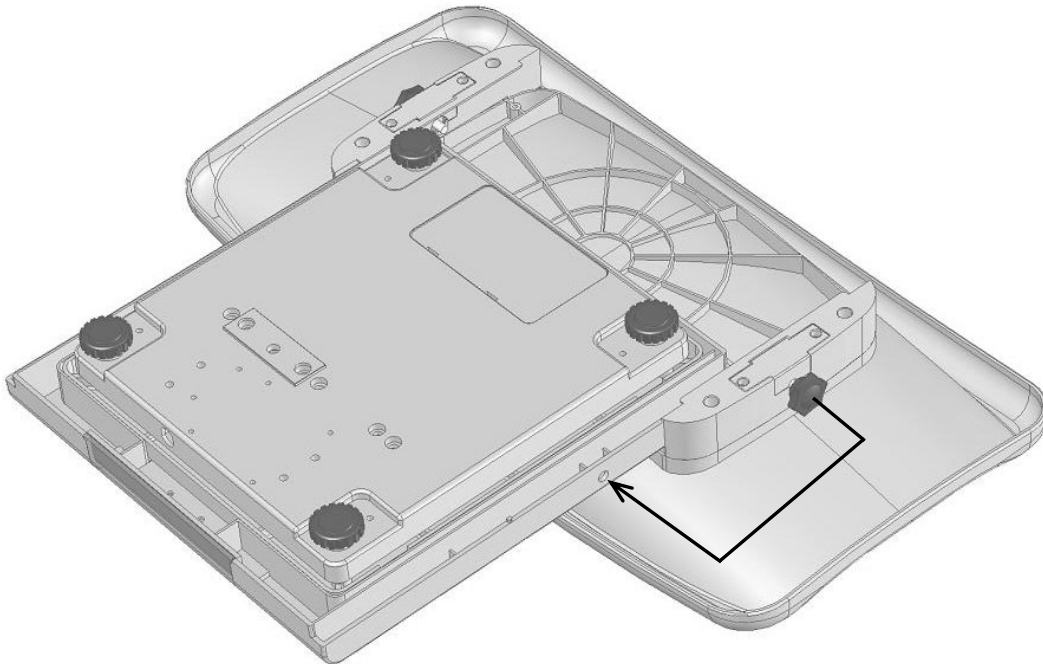

BABY TRAY INSTALLATION, CONT.

3. Hand-tighten the screws to secure the tray to the platform

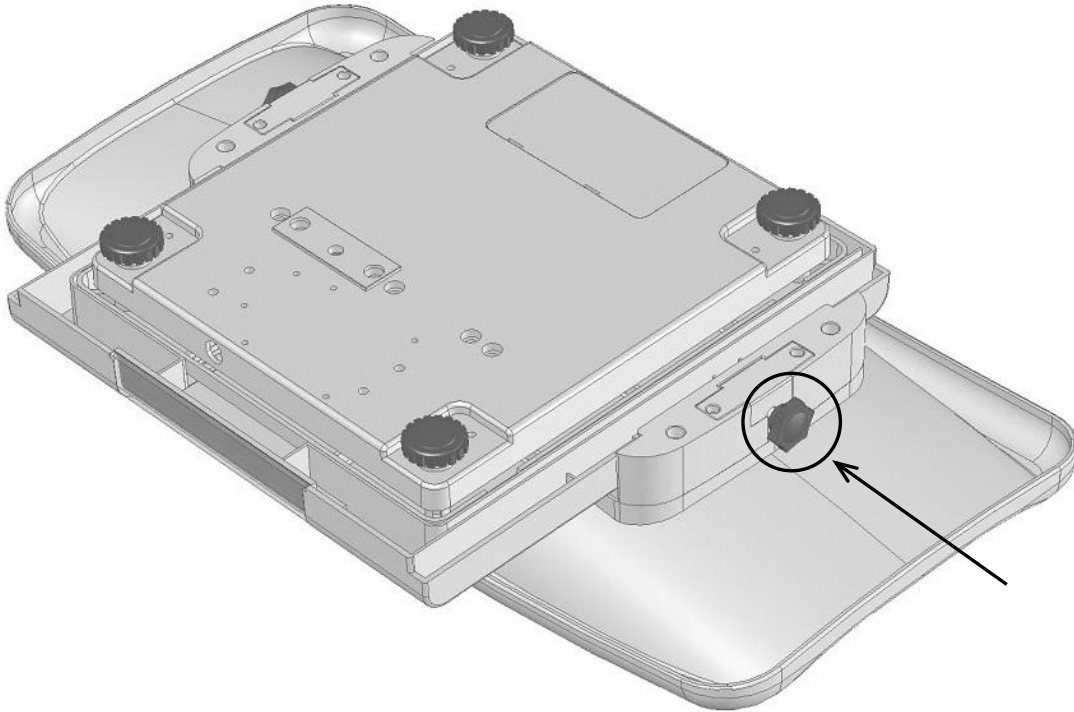

4. Scale assembly is finished. Turn scale over to begin weighing operations.



AC POWER ADAPTOR

2. Locate AC Power adaptor jack at front of scale. The AC power jack is located on the lower front right of the scale next to the Weight Unit Switch.

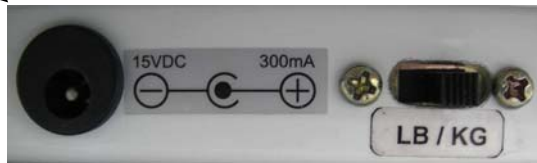
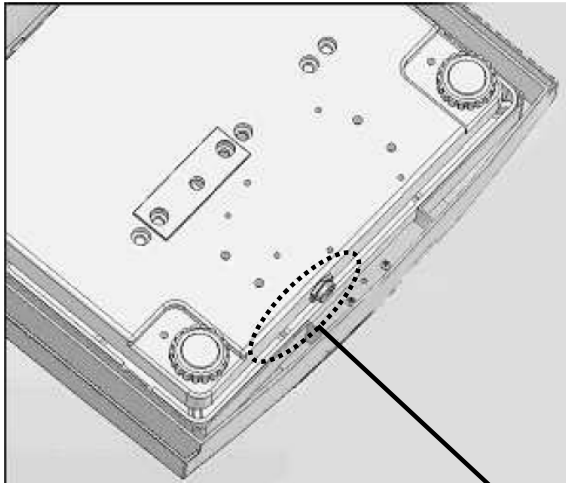

**AC Power
Adapter Jack**

**Weight Unit
Switch**

2. Install AC Power Adaptor into jack on front of scale as shown below.

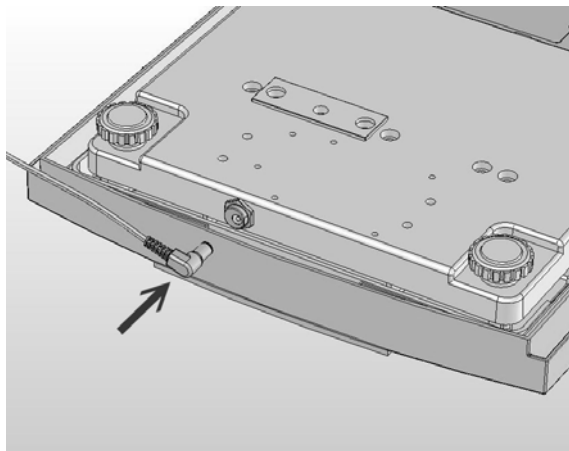

INSTALLING/REPLACING THE BATTERIES

The scale use six "AA" alkaline batteries (*not included*). You must first obtain and install batteries before operations can begin. Batteries are contained in a battery holder inside the scale. Access is via a removable panel on the bottom of the scale.

1. Turn the scale over so that the display is facing down.
2. Locate the rectangular panel on the bottom of the scale.
3. To install or replace the batteries, first remove the battery holder cover by pushing in on the tab and lifting it up.
4. If installing new batteries, proceed to step 5. If replacing the batteries, remove all 6 batteries from the battery holder and then proceed to step 5.

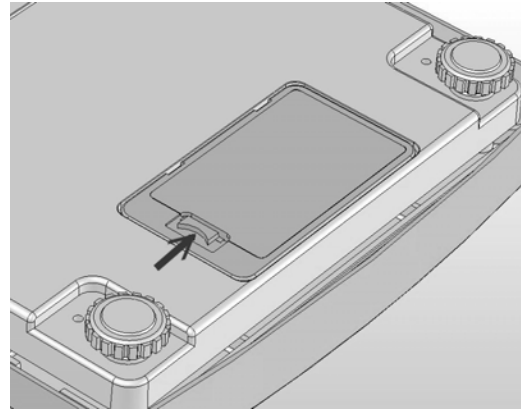

5. Install the 6 new "AA" batteries in the battery holder, noting the polarity markings located in the battery holder.

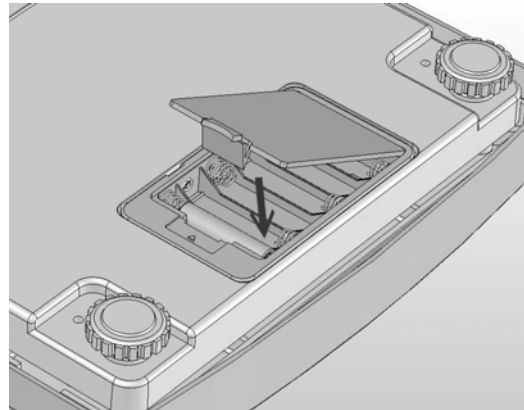
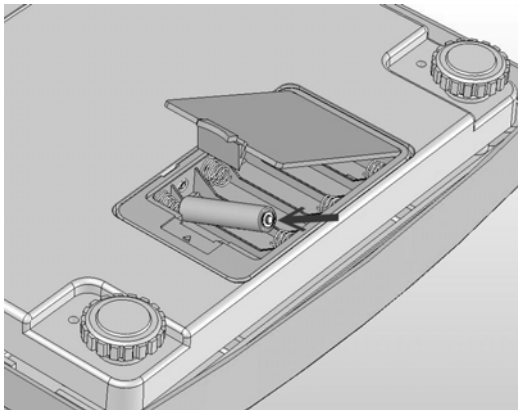

6. After placing all 6 batteries in the holder, replace the battery cover.
7. Turn the scale over (display facing up) and press the **On/Off** key.
8. If the scale turns on, the batteries have been installed correctly. If not, remove the panel and check for one or more improperly positioned batteries.
9. The scale is now ready for normal weighing operations.

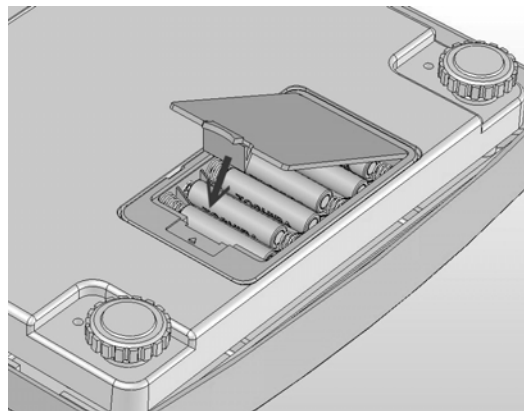

KEY FUNCTIONS

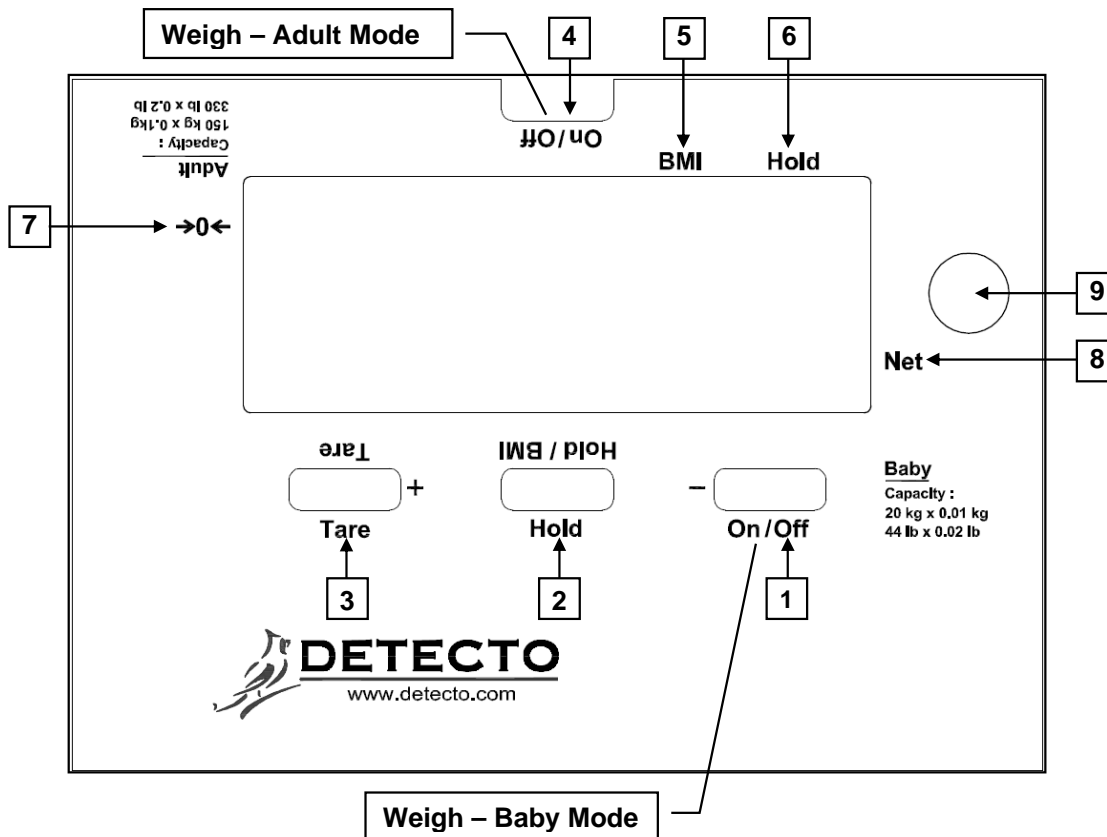

NEVER leave an infant, child or patient unattended while on the scale. Failure to maintain control of infant, child or patient at all times while they are on the scale can result in serious injury to infant, child or patient.

1. On/Off (Baby Mode)

1. Press this key to turn the scale ON.
2. With scale on, press this key to turn the scale OFF.

2. Hold (Baby Mode)

1. Press this key to hold the weight value while weighing.
2. Press this key again to disable the weight hold function.

Hold/BMI (Adult Mode)

1. Press this key to hold the weight value while weighing.
2. Press this key again to disable the weight hold function.
3. Press and hold this key for 3 seconds to enter the BMI (Body Mass Index) mode to calculate body fat.

3. Tare (Baby and Adult Mode)

Press this key to zero the scale before starting the weighing operation or to zero off the weight of any item (i.e. protective paper, blanket or pad) on the scale or in the baby tray.

4. On/Off (Adult Mode)

1. Press this key to turn the scale ON.
2. With scale on, press this key to turn the scale OFF.

(-) Minus Sign, Adult Mode

In the Adult mode, this key is used with the BMI feature to “decrease” the height value.

[+], Plus Sign (Adult Mode)

In the Adult Mode, this key is used with the BMI feature to “increase” the height value.

DISPLAY ANNUNCIATORS

5. **BMI** This annunciator is turned on when entering the height for the BMI feature and when displaying the calculated body fat.
 6. **Hold** This annunciator will be turned on and *Hold* be shown on the display for a few seconds to indicate that the weight from the last weighing operation is being held and the baby, child or adult can be removed from the scale. This feature is useful if the baby or child is very active.
 7. **→0←** This annunciator is on the side of the display. An arrow will be turned on to indicate the weight is at zero and the scale is ready to use.
 8. **Net** The annunciator is on the side of the display. An arrow will be turned on to show that the weight displayed is net weight. Net weight is determined by zeroing the weight of an item from the scale such as protective paper, blankets, pads or toys. This insures that only the baby or adult's weight is displayed.
- kg** The **kg** annunciator is turned on to indicate the weight shown is in kilograms.
- lb** The **lb** annunciator is turned on to indicate the weight shown is in pounds.

LEVEL INDICATOR

9. **Level Indicator** The level indicator is located to the side of the display. If the scale is not level (bubble will not be centered), adjust mounting feet as required to center bubble and attain a level scale.

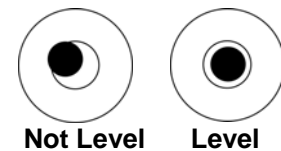

WEIGHT UNIT SWITCH

The Weight Unit Switch is located on the lower front right of the scale next to the AC power adapter jack. It allows to operator to easily change the weight units from pound to kilograms or kilograms to pounds.

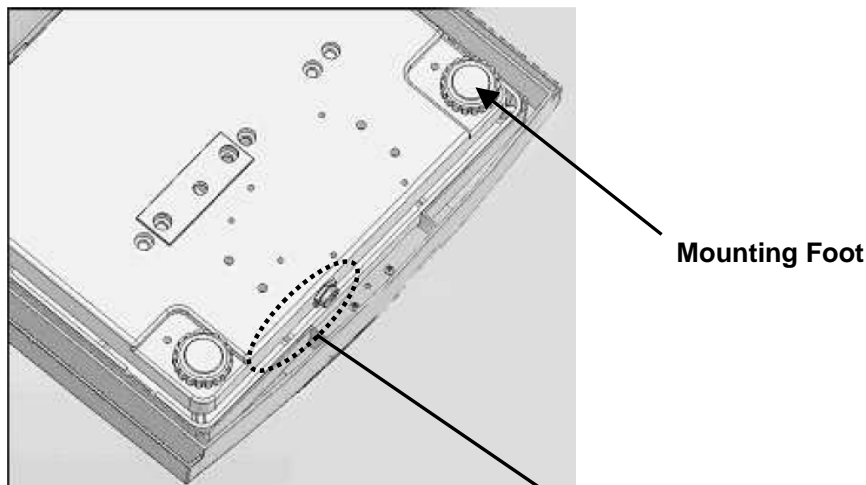

**AC Power
Adapter Jack**

**Weight Unit
Switch**

HOW TO USE THE BMI FEATURE

1. Press the Adult mode **On/Off** button.
2. Make sure the display is showing *0.0*. If not, press the **Tare** key.
3. Press and hold the **Hold/BMI** key.
4. The display will momentarily show *HOLD* and then change to show the last height. Note that the BMI annunciator will be turned on and that the height value will be flashing
5. Enter the new height by pressing the (**+**) key to increase the value or by pressing the (**-**) key to decrease the value.

NOTE! Press and hold the (**+**) or (**-**) key to change the rapidly change the value.

6. When the correct value for the height is displayed, press the **Hold/BMI** key.
7. The display will change to show *HOLD* and the Hold annunciator will be blinking.
8. Have the patient step on to the scale.
9. The scale will show the weight and then change to show the BMI value alternating between the weight and BMI value.
10. Press **Hold/BMI** button to return the normal weighing mode.
11. The patient can now step off the scale.

SETTING THE AUTO-OFF TIME

1. Press either the Adult or the Baby mode **On/Off** key.
2. Press and hold the **Tare** key until the display shows *5Et*.
3. Release the **Tare** key. The display will change to *R_OFF*.
4. Press the **Tare** key. The display will change to show the current setting.
5. Press the **Hold** or **Hold/BMI** key to step through the available auto-off times.
6. When the desired time is displayed, press the **Tare** key.
7. The display will change to *R_OFF*.
8. Press the **Hold** or **Hold/BMI** key. The display will change to *End*.
9. Press the **Tare** key. The scale will reset.
10. The scale is ready for normal weighing operations.



IMPORTANT: The Auto-Off feature ONLY works when the scale is powered by the six “AA” batteries.

ERROR MESSAGES

Low Battery

This message indicates that the battery should be replaced soon. If the battery voltage drops too low, continued use with a low battery can affect weighing accuracy. Remove the old battery and replace with a new battery for operation.

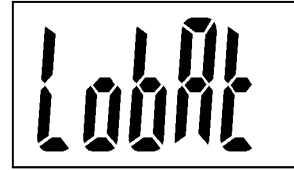

Over Load

The load is over the scale capacity. Reduce the load and try again. If the trouble still exists, please call your scale service representative.

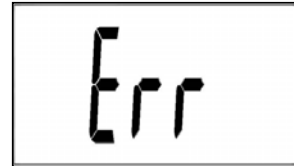

Over Zero

The load is over the limit the scale can zero when powering on. Reduce the load and try again. If the trouble still exists, please call your scale service representative.

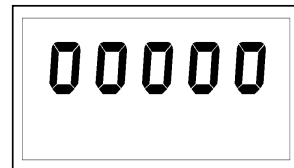

Under Zero

The load is under the limit when powering on. Power OFF scale and try again. If the trouble still exists, call your scale service representative.



