

DAM-E3013

User's Manual



Beijing ART Technology Development Co., Ltd.

DAM-E3013 Module

Introduction

16-ch Isolated Digital Input

General

- Power Supply: unregulated 10~30V_{DC}
- Build-in watchdogs
- Support 10/100Mbps Ethernet
- Provide default web page or custom-built web page
- Power Consumption: 2W@24V_{DC}

Digital Input

- Channels: 16
- Input Level
 - Wet Contact: Logic Level 0: +1V max, Logic Level 1: 4V~30V
 - Dry Contact: ground or open circuit
- Isolated Voltage: 3,750V
- Input channel can be used as a 500Hz counter

Easy to operate

DAM-E3013 utility software can help you to select input configuration, set the operating parameter for your process control needed.

Industrial Design

DAM-E3013 was designed to use in industrial environment. It can be installed in standard DIN rail inside the cabinet. And it can be powered by unregulated 10~30V_{DC} to meet the various power supplied source in field. It also withstands ambient temperature up to 60°C and resists the effects of vibration and mechanical shock.

Wiring & Installation

Power supply requirements: unregulated +10 V_{DC} ~ +30 V_{DC}. "+Vs" is a positive, and "GND" is ground. The Ethernet interface is connected to a computer switch directly via network cable. If the wiring and power is ok, then the power indicator should be stop flash and keep on. The module initialization is completed. The indicator flashes according to the transmitted data when the module is working.

DAM-E3013

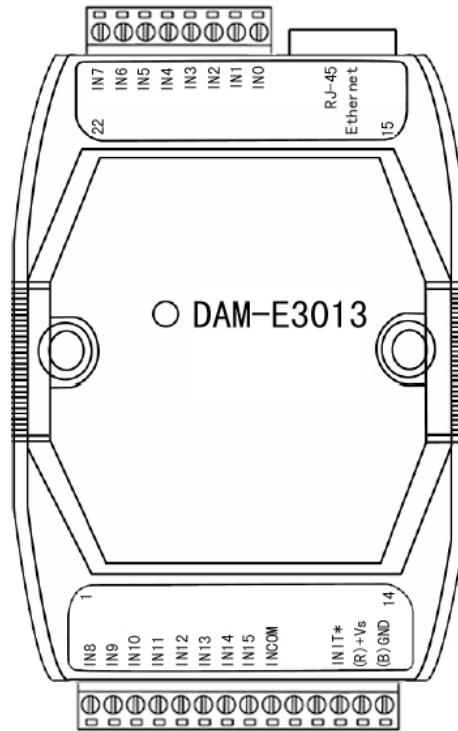

Fig.1 DAM-E3013 Drawing

DAM-E3013 can be installed in standard DIN rail inside the cabinet; it also can be installed by stacking mode.

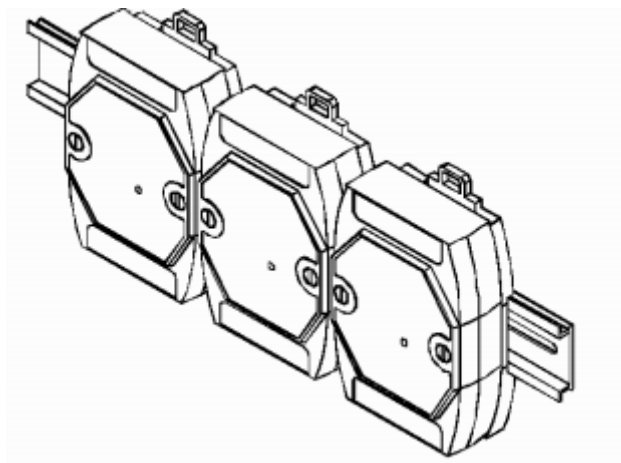

Fig.2 DAM-E3013 standard DIN installation

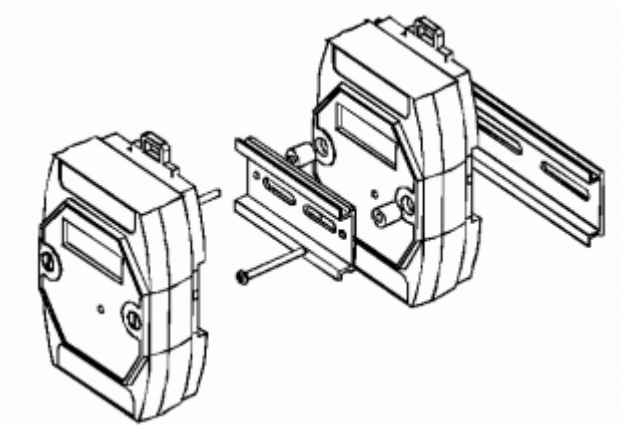

Fig.3 DAM-E3013 stack installation

Application Wiring

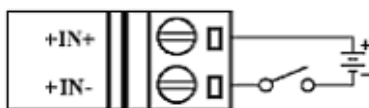

Fig.4 dry contact



Fig.5 wet contact

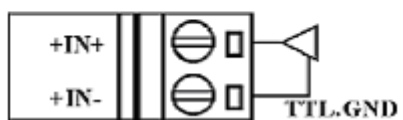
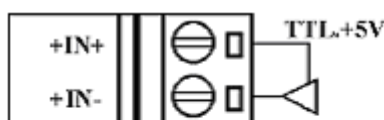

Fig.6 TTL/CMOS signal input

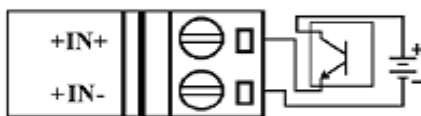
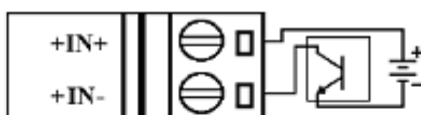

Fig.7 Open-collector signal input

Jumper

JP1: shorted 1-pin and 2-pin, it is dry contact mode.



JP1: shorted 2-pin and 3-pin, it is wet contact mode.



Default Setting

If the module's network configuration is wrong, or forget the last modified value, the module can be reverted to default settings. Steps: short-circuit the "INIT*" and "GND" when there is no power; power-on for 3 seconds, power off, disconnect "INIT*" and "GND". The module is reverted to the default settings.

1. IP Address: 192.168.2.80
2. Subnet Mask: 255.255.255.0
3. Default Gateway: 192.168.2.1
4. TCP Port: 502
5. HTTP Port: 80

Operation Interface

Click the "DAME3000" in "ART Data Acquisition Measurement Suite" to open the device test system of DAM-E3000 Modules.

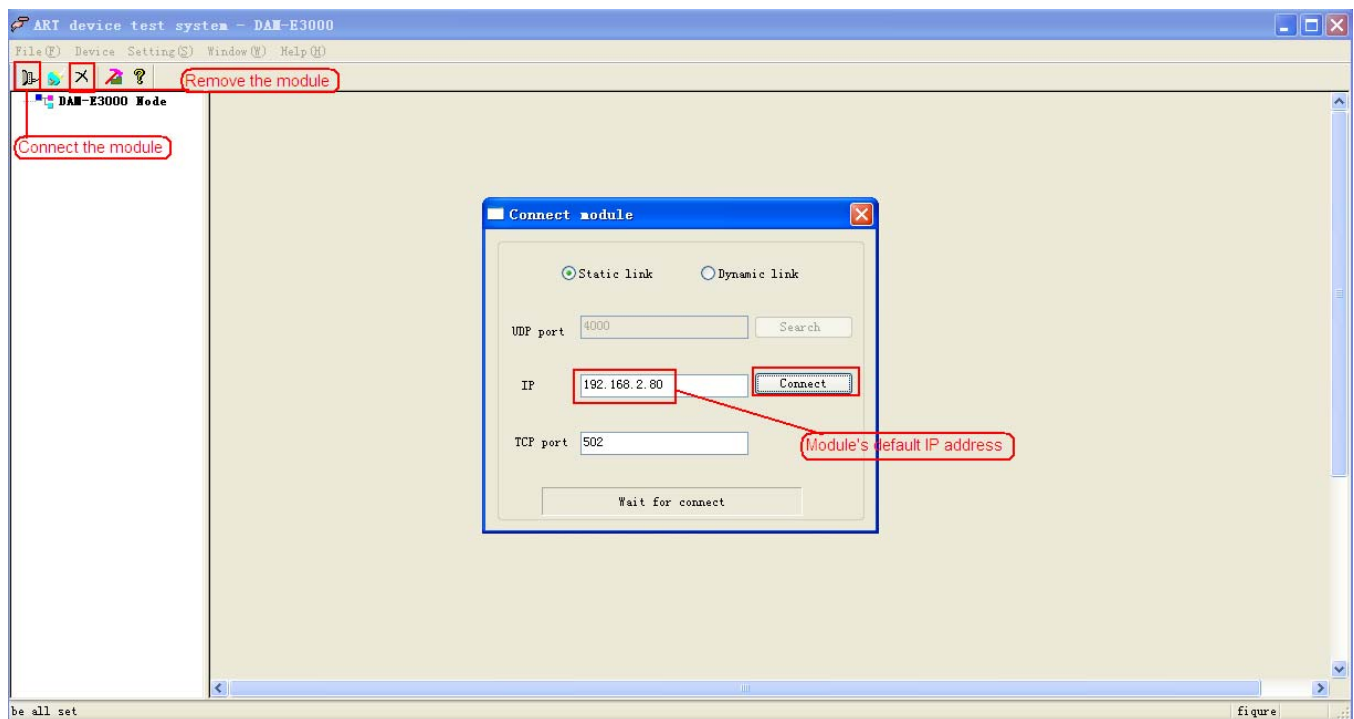

Configure parameters:

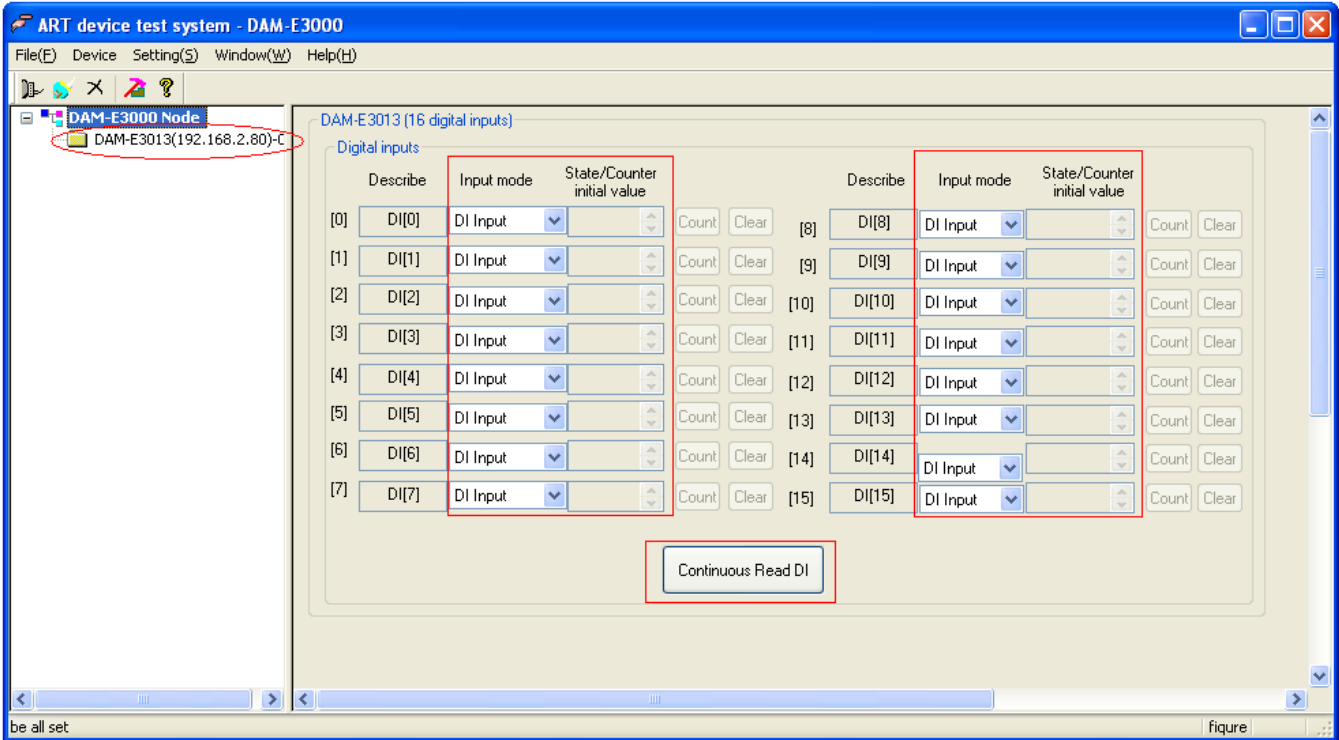

Dbclicking the “DAM-E3013: 192.168.2.80-0” in the system tree of left dialog block to get “Network configure info” box, in this box, we can set “IP” and “Device name” and “TCP port”.

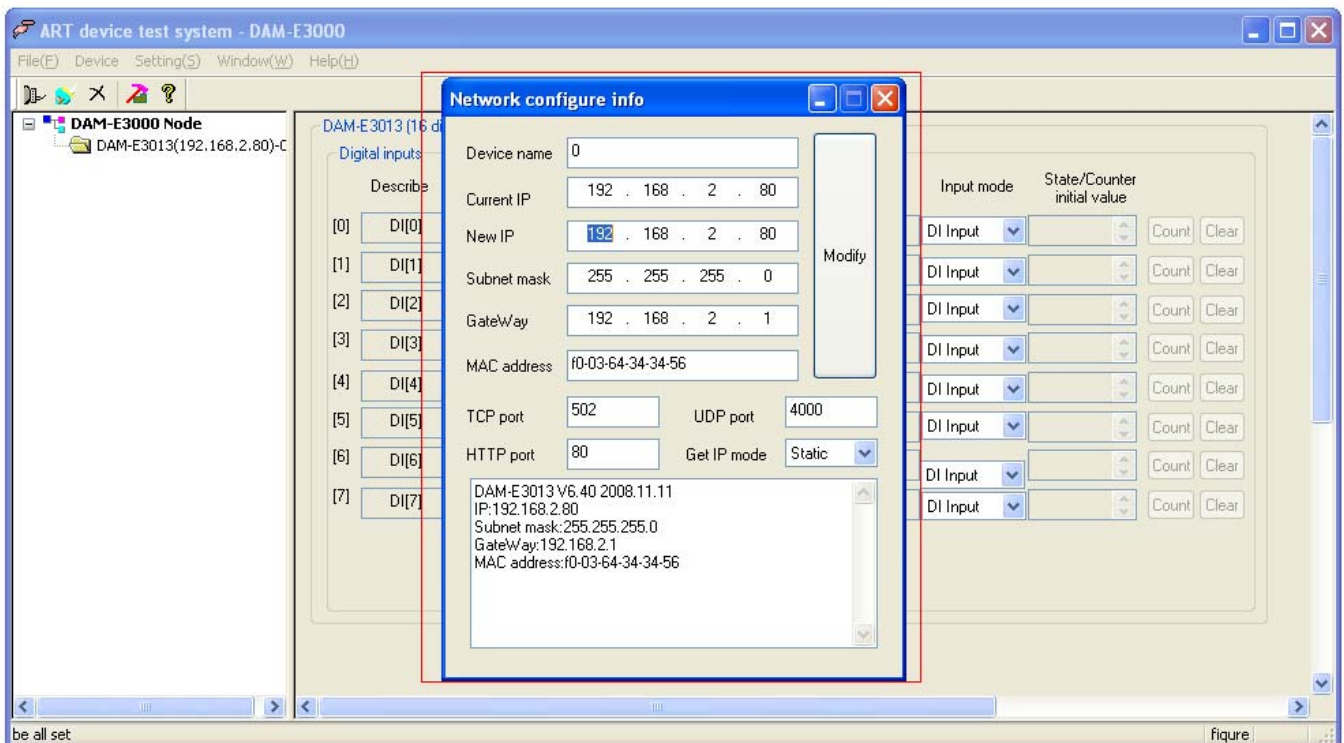

Communication Protocol

At present, Ethernet Distributed Acquisition Modules of our company use MODBUS TCP mode. Supported function code includes the following categories:

- 01 READ COIL STATUS
- 02 READ INPUT STATUS
- 03 READ HOLDING REGISTERS
- 04 READ INPUT REGISTERS
- 05 FORCE SINGLE COIL
- 06 PRESET SINGLE REGISTER
- 15 FORCE MULTIPLE COILS
- 16 FORCE MULTIPLE REGISTERS
- 20 READ FILE RECORD
- 21 WRITE FILE RECORD

Address Mapping Table

Read Switch Input

Function Code: 02

Description: Read input switch status

Data Description

Address	Description	Note
10001-10016	For Switch Input Status	16 Channels, 0 for no power, 1 for power on
Reservation		
10033-10048	For Rising Edge Latched Status	16 Channels, 0 for No Latch, 1 for Latch
Reservation		
10065-10080	For Falling Edge Latched Status	16 Channels, 0 for No Latch, 1 for Latch

Request

Domain Name	Byte	Value
Function Code	1 byte	0×02
Start Address	2 bytes	0×0000 to 0×FFFF
Read Amount	2 bytes	1 to 2000 (0×7D0)

Response

Domain Name	Byte	Value
Function Code	1 byte	0×02
Byte Count	1 byte	N= (Read Amount+7)/8
Input State	n bytes	

Exception

Domain Name	Byte	Value
Function Code	1 byte	0×02+0×80
Byte Count	1 byte	0×1 or 0×2

Example

Request		Response	
Domain Name	Data (hex)	Domain Name	Data (hex)

Function Code	02	Function Code	02
Start Address H (byte)	00	Byte Count	03
Start Address L (byte)	C4	204(h)~197 status	AC
Read Amount H (byte)	00	212(h)~205 status	DB
Read Amount L (byte)	16	218(h)~213 status	35

Read Holding Register

Function Code: 03

Note: Read the holding register value

Data Description:

40065	For Ch01 Switch Pulse Count L	16 bits
40066	For Ch01 Switch Pulse Count H	16 bits
40067	For Ch02 Switch Pulse Count L	16 bits
40068	For Ch02 Switch Pulse Count H	16 bits
40069	For Ch03 Switch Pulse Count L	16 bits
40070	For Ch03 Switch Pulse Count H	16 bits
40071	For Ch04 Switch Pulse Count L	16 bits
40072	For Ch04 Switch Pulse Count H	16 bits
40073	For Ch05 Switch Pulse Count L	16 bits
40074	For Ch05 Switch Pulse Count H	16 bits
40075	For Ch06 Switch Pulse Count L	16 bits
40076	For Ch06 Switch Pulse Count H	16 bits
40077	For Ch07 Switch Pulse Count L	16 bits
40078	For Ch07 Switch Pulse Count H	16 bits
40079	For Ch08 Switch Pulse Count L	16 bits
40080	For Ch08 Switch Pulse Count H	16 bits
40081	For Ch09 Switch Pulse Count L	16 bits
40082	For Ch09 Switch Pulse Count H	16 bits
40083	For Ch10 Switch Pulse Count L	16 bits
40084	For Ch10 Switch Pulse Count H	16 bits
40085	For Ch11 Switch Pulse Count L	16 bits
40086	For Ch11 Switch Pulse Count H	16 bits
40087	For Ch12 Switch Pulse Count L	16 bits
40088	For Ch12 Switch Pulse Count H	16 bits
40089	For Ch13 Switch Pulse Count L	16 bits
40090	For Ch13 Switch Pulse Count H	16 bits
40091	For Ch14 Switch Pulse Count L	16 bits
40092	For Ch14 Switch Pulse Count H	16 bits
40093	For Ch15 Switch Pulse Count L	16 bits
40094	For Ch15 Switch Pulse Count H	16 bits
40095	For Ch16 Switch Pulse Count L	16 bits
40096	For Ch16 Switch Pulse Count H	16 bits
Reservation		
40130	For Input Latch Enable Register	Set bit: Enabled; Space: Disabled

40131	For Input Count Enable Register	Set bit: Enabled; Space: Disabled
40132	For Input Count Mode Register	Set bit: Rise; Space: Fall
Reservation		
40513	For Watchdog Control Register	bit0: 0 disabled, 1 enabled bit1: 0 normal, 1 overflow bit2: 0 normal, 1 reset
40514	For Watchdog Overflow Register	Watchdog Overtime Constant
40515	For Watchdog Reset Register	0x55AA
Reservation		

Request

Domain Name	Byte	Value
Function Code	1 byte	0×03
Start Address	2 bytes	0×0000 to 0×FFFF
Read Amount	2 bytes	1 to 125 (0×7D)

Response

Domain Name	Byte	Value
Function Code	1 byte	0×03
Byte Count	1 byte	2n
Input Status	2n bytes	

Exception

Domain Name	Byte	Value
Function Code	1 byte	0×03+0×80
Error Code	1 byte	0×1 or 0×2

Example

Request		Response	
Domain Name	Data (hex)	Domain Name	Data (hex)
Function Code	03	Function Code	03
Start Address H (byte)	00	Byte Count	02
Start Address L (byte)	08	Input Register High	00
Read Amount H (byte)	00	Input Register Low	0A
Read Amount L (byte)	01		

Note 1: The unit of the pulse output level width: millisecond

The unit of the watchdog timer length: millisecond

Note 2: When power on, the highest bit of the watchdog control register is 1, can be done to do determine whether the module is rested or not.

Write Single Relay

Function Code: 05

Request

Domain Name	Byte	Value
Function Code	1 byte	0×05
Address Setting	2 bytes	0×0000 to 0×FFFF

Content Setting	2 bytes	0x0000 or 0xFF00 0x0000 release relay 0xFF00 engage relay
-----------------	---------	---

Response

Domain Name	Byte	Value
Function Code	1 byte	0x05
Address Setting	2 bytes	0x0000 to 0xFFFF
Content Setting	2 bytes	0x0000 or 0xFF00

Exception

Domain Name	Byte	Value
Function Code	1 byte	0x05+0x80
Error Code	1 byte	0x1 or 0x2

Example

Request		Response	
Domain Name	Data (hex)	Domain Name	Data (hex)
Function Code	05	Function Code	05
Set Address H (byte)	00	Set Address H (byte)	00
Set Address L (byte)	05	Set Address L (byte)	05
Set Content H (byte)	FF	Set Content H (byte)	FF
Set Content L (byte)	00	Set Content L (byte)	00

Set Single Holding Register

Function Code: 06

MODBUS Request

Domain Name	Byte	Value
Function Code	1 byte	0×06
Address Setting	2 bytes	0×0000 to 0×FFFF
Content Setting	2 bytes	0×0000 to 0×FFFF

MODBUS Response

Domain Name	Byte	Value
Function Code	1 byte	0×06
Address Setting	2 bytes	0×0000 to 0×FFFF
Content Setting	2 bytes	0×0000 to 0×FFFF

Exception

Domain Name	Byte	Value
Function Code	1 byte	0×06+0×80
Error Code	1 byte	0×1 or 0×2

Example

Request		Response	
Domain Name	Data(hex)	Domain Name	Data(hex)
Function Code	06	Function Code	06
Set Address High (byte)	00	Set Address High (byte)	00

Set Address Low (byte)	08	Set Address Low (byte)	08
Set Content High (byte)	00	Set Content High (byte)	00
Set Content Low (byte)	19	Set Content Low (byte)	19

Set Multiple Relay

Function Code: 0F

Request

Domain Name	Byte	Value
Function Code	1 byte	0×0F
Start Address Setting	2 bytes	0×0000 to 0×FFFF
Length Setting	2 bytes	0×0000 to 0×07B0
Byte count	1 byte	n
Content Setting	n bytes	

Response

Domain Name	Byte	Value
Function Code	1 byte	0×0F
Start Address Setting	2 bytes	0×0000 to 0×FFFF
Length Setting	2 bytes	0×0000 to 0×07B0

Exception

Domain Name	Byte	Value
Function Code	1 byte	0×0F+0×80
Error Code	1 byte	0×1 or 0×2

Example

Request		Response	
Domain Name	Data(hex)	Domain Name	Data(hex)
Function Code	0F	Function Code	0F
Set Address High (byte)	00	Set Address High (byte)	00
Set Address Low (byte)	13	Set Address Low (byte)	13
Set Amount High (byte)	00	Set Amount High (byte)	00
Set Amount Low (byte)	0A	Set Amount Low (byte)	0A
Byte count	02		
Set Content High (byte)	CD		
Set Content Low (byte)	01		

Set Multiple Holding Registers

Function Code: 10

Request

Domain Name	Byte	Value
Function Code	1 byte	0×10
Start Address Setting	2 bytes	0×0000 to 0×FFFF
Length Setting	2 bytes	0×0000 to 0×07B0
Byte count	1 byte	2n
Content Setting	2n bytes	

Response

Domain Name	Byte	Value
Function Code	1 byte	0×10
Start Address Setting	2 bytes	0×0000 to 0×FFFF
Length Setting	2 bytes	0×0000 to 0×07B0

Exception

Domain Name	Byte	Value
Function Code	1 byte	0×10+ 0×80
Error Code	1 byte	0×1 or 0×2

Example

Request		Response	
Domain Name	Data(hex)	Domain Name	Data(hex)
Function Code	10	Function Code	10
Set Address High (byte)	00	Set Address High (byte)	00
Set Address Low (byte)	01	Set Address Low (byte)	01
Set Amount High(byte)	00	Set Amount High(byte)	00
Set Amount Low (byte)	02	Set Amount Low (byte)	02
Byte count	04		
Set Content High (byte)	00		
Set Content Low (byte)	0A		
Set Content High (byte)	01		
Set Content Low (byte)	02		

Read File Record

Function Code: 14/06

Read file record: in MODBUS, file is considered to be 16-bit array, addressing according to address. Read file: set the start address and read length and change the Start Address and Read Length can traverse the entire file. The file does not have a name, it has number only. You can only read and write one file at one time.

Request

Domain Name	Byte	Value
Function Code	1 byte	0×14
Byte Count	1 byte	0×07 to 0×F5
Sub Function Code	1 byte	0×06
File Number	2 bytes	0x0000 to 0xFFFF
Record Number	2 bytes	0x0000 to 0x270F
Read Length	2 bytes	n
Sub Function Code	1 byte	0x06
.....	

Response

Domain Name	Byte	Value
Function Code	1 byte	0×14
Byte Count	1 byte	0x07 to 0xF5

Sub Function Byte Count	1 byte	0x07 to 0xF5
Sub Function Code	1 byte	0x06
Data	2n bytes	

Exception

Domain Name	Byte	Value
Function Code	1 byte	0×14+ 0×80
Error Code	1 byte	0×1 or 0×2

Example

Request		Response	
Domain Name	Data(hex)	Domain Name	Data(hex)
Function Code	14	Function Code	14
Byte Count	07	Byte Count	06
Sub Function Code	06	Respond Count	05
File Number High (byte)	00	Sub Function Code	06
File Number Low(byte)	04	Record Data High(byte)	0D
Record Number High(byte)	00	Record Date Low(byte)	FE
Record Number Low(byte)	01	Record Data High(byte)	00
Read Length High(byte)	00	Record Date Low(byte)	20
Read Length Low(byte)	02		

Write File Record

Function Code: 15/06

Request

Domain Name	Byte	Value
Function Code	1 byte	0×15
Byte Count	1 byte	0×07 to 0×F5
Sub Function Code	1 byte	0×06
File Number	2 bytes	0x0000 to 0xFFFF
Record Number	2 bytes	0x0000 to 0x270F
Read Length	2 byte s	n
Data	2n bytes	
.....	

Response

Domain Name	Byte	Value
Function Code	1 byte	0×15
Byte Count	1 byte	0x07 to 0xF5
Sub Function Code	1 byte	0x06
File Number	2 bytes	0x0000 to 0xFFFF
Record Number	2 bytes	0x0000 to 0x270F
Write Length	2 bytes	n
Data	2n bytes	

Exception

Domain Name	Byte	Value
Function Code	1 byte	0×15+ 0×80
Error Code	1 byte	0×1 or 0×2

Example

Request		Response	
Domain Name	Data(hex)	Domain Name	Data(hex)
Function Code	15	Function Code	15
Byte Count	0B	Byte Count	0B
Sub Function Code	06	Sub Function Code	06
File Number High (byte)	00	File Number High (byte)	00
File Number Low(byte)	04	File Number Low (byte)	04
Record Number High(byte)	00	Record Number High(byte)	00
Record Number Low(byte)	01	Record Number Low(byte)	01
Read Length High(byte)	00	Write Length High(byte)	00
Read Length Low(byte)	02	Write Length Low(byte)	02
Write Data	4 bytes	Write Data	4 bytes

EEPROM Assignment

```
//file 0
#define MODULE_NET_ADDR          0x0000
#define MODULE_VER_ADDR          0x0020
//file 1
#define NET_CONFIG_ADDR          0x0000
//file 2 to file 7
.....
```

Note:

EEPROM is 8kbyte capacity, divide to 8 file blocks, every block 1kbyte.

1. MODULE_NET_ADDR

Restore to factory defaults network configuration parameter.

Byte	4	4	4	6
Content	IP Address	Default Gateway	Subnet Mask	MAC Address

2. MODULE_VER_ADDR

Module Version Information:

Byte	42byte
Content	DAM-E3012 V6.20 2006.09.01 ID:DAME123456

3. NET_CONFIG_ADDR

Network configuration parameter, call table 1 for structures.