

# **User Manual for the CR:800B Series of Sound Level Meters**



This manual, the software to which it relates, the  
program code and drawings are all:

© Copyright Cirrus Research plc 1989-2014

---

The content of this manual, any illustrations, technical information and descriptions within this document were correct at the time of going to print. Cirrus Research plc reserves the right to make any changes necessary, without notice, in line with the policy of continuing product development and improvement.

No part of this publication may be duplicated, reprinted, stored in a data processing system or transmitted by electronic, mechanical, photographic or other means, or recorded, translated, edited, abridged or expanded without the prior written consent of Cirrus Research plc.

No liability is accepted for any inaccuracies or omissions in this manual, although due care has been taken to ensure that it is complete and accurate as possible.

Accessories supplied by Cirrus Research plc have been designed for use with the instrumentation manufactured by Cirrus Research plc. No responsibility is accepted for damage caused by the use of any other parts or accessories.

In order to take account of a policy of continual development, Cirrus Research plc reserves the right to change any of the information contained in this publication without prior notice.

Produced by Cirrus Research plc, Acoustic House, Bridlington Road, Hunmanby, North Yorkshire, YO14 0PH, United Kingdom.

© Copyright Cirrus Research plc 2014

Reference Number 10/14/CR:800B/04

Document Printing Date Wednesday, 29 October 2014

---

<b>Preface</b> .....	<b>6</b>
Messages and Symbols .....	6
<b>Section 1 Introduction</b> .....	<b>7</b>
Main Features .....	7
Measurement Functions.....	7
Broadband Measurement Mode .....	7
1:1 & 1:3 Octave Band Measurement Mode .....	8
Options & Accessories .....	8
<b>Section 2 Getting Started</b> .....	<b>9</b>
How to... .....	9
Make a 15 minute Broadband Measurement .....	9
Make a 1:1 Octave Band Measurement over 1 minute .....	9
Make a 1:3 Octave Band Measurement over 5 minutes .....	9
Make a set of twenty four 1 hour measurements.....	9
Quick Start .....	10
Switch on.....	10
Calibrate the Sound Level Meter .....	10
Set the measurement duration .....	11
Check the measurement range .....	11
Change the measurement function .....	12
Start & Stop the measurement .....	12
Review the measurement.....	13
Unpacking and checking the Sound Level Meter .....	14
Installing the software .....	14
Assembly .....	14
Preamplifier.....	14
Using Microphone Extension Cables .....	16
Batteries.....	16
Using an external power supply .....	17
Windshield .....	17
NK:70 Random Incidence Adaptor.....	17
Switching On .....	18
Checking the Configuration of the Instrument .....	19
Time and Date.....	19
Measurement Range.....	19
Measurement Mode .....	20
Measurement Duration .....	20
Measurement Auto Repeat .....	21
Measurement Auto Synchronise.....	21
Configuring the instrument from the Deaf Defier3 software .....	21
Calibration.....	21
Starting a measurement.....	23
Broadband Mode.....	23
1:1 Octave Band Mode .....	23
1:3 Octave Band Mode .....	24
Displaying the data during a measurement .....	25
Broadband Mode.....	25
Pausing and Resetting a measurement.....	26
Stopping the measurement.....	26
Viewing the stored measurements .....	27
After a measurement has been stopped.....	27
Recalling stored measurements .....	27
<b>Section 3 Configuring the Sound Level Meter</b> .....	<b>28</b>
Keypad .....	28
Menu System.....	28
Measurement Mode .....	29
Broadband Mode.....	29
1:1 Octave Band Mode .....	30
1:3 Octave Band Mode .....	30

Measurement Duration .....	31
Measurement Auto Repeat .....	33
Measurement Auto Synchronise .....	34
Measurement Range .....	35
Instrument Setup .....	37
Display Contrast .....	37
Time & Date .....	38
Calibration Level .....	38
Display Resolution .....	39
Time Weighting .....	40
Frequency Weighting .....	41
Ln values .....	41
User Metric .....	42
Configuring the instrument from the Deaf Defier3 software .....	43
<b>Section 4 Viewing and Downloading the measurements .....</b>	<b>44</b>
Recalling Stored Measurements .....	44
Broadband Measurement .....	45
1:1 Octave Band Measurements .....	45
1:3 Octave Band Measurements .....	46
Checking & Clearing the memory .....	48
Downloading Measurements to the Software .....	49
Software Installation .....	49
Connecting the instrument to the PC .....	49
Understanding how the measurements are stored .....	51
<b>Section 5 Maintenance &amp; Care .....</b>	<b>53</b>
<b>Section 6 Troubleshooting .....</b>	<b>54</b>
Basics .....	54
Calibration .....	54
Measurements & Settings .....	54
Downloading Measurements .....	55
<b>Section 7 Glossary .....</b>	<b>56</b>
<b>Appendix 1 Menu Structure .....</b>	<b>59</b>
<b>Appendix 2 Rating Plate Information .....</b>	<b>61</b>
Additional information .....	61
Additional filter information .....	64
<b>Appendix 3 Specifications .....</b>	<b>67</b>
Memory .....	69
Weight .....	70
Dimensions .....	70
Batteries .....	70
Battery Life .....	70
Environmental .....	70
External Connections .....	70
Outputs .....	70
Output Cables .....	71
External Power .....	71
Software Support .....	71
System Requirements .....	71
Factory Options .....	72
Electromagnetic Performance .....	72
<b>Appendix 4 Acoustic Calibrators .....</b>	<b>73</b>
Operation .....	73
Switching on the Calibrator .....	73
Permanent-on Mode .....	73
Calibrating a Sound Level Meter .....	74
Background Noise .....	74
Stabilisation .....	74

---

Changing the Battery .....	75
Battery type.....	75
Specification.....	76
Technical Information .....	77
Free Field Correction.....	78
Microphone Correction Values.....	78
Example .....	78
<b>Appendix 5 Software Installation .....</b>	<b>79</b>
System Requirements .....	79
Installation Requirements.....	79
<b>Appendix 6 Configuring the instrument from the software.....</b>	<b>80</b>
<b>Appendix 7 CE Certificate of Conformity .....</b>	<b>81</b>
<b>Warranty Information. ....</b>	<b>82</b>
<b>Cirrus Research Offices .....</b>	<b>83</b>

---

## Preface

Thank you for purchasing the CR:800B Sound Level Meter. This powerful instrument provides excellent expansion capability, and has been designed to provide reliable, accurate measurements over a long period of time.

This manual describes the procedure that should be followed to set up and operate the CR:800B Sound Level Meter, as well as comprehensive technical information, using optional accessories as well as troubleshooting.

This manual also contains the information regarding the CR:514 and CR:515 Acoustic Calibrators which has been supplied previously as a separate manual.

If you are a new user of Sound Level Meters or new to the CR:800B Sound Level Meter, first read Section 1 Introduction to familiarise yourself with the features, components and accessories supplied. Then read Section 2 Getting Started for step-by-step instructions on how to use the instrument.

The different versions of the CR:800B are:

CR:811B	Type 1 Broadband Only
CR:812B	Type 2 Broadband Only
CR:821B	Type 1 Broadband with 1:1 Octave Band Filters
CR:822B	Type 2 Broadband with 1:1 Octave Band Filters
CR:831B	Type 1 Broadband with 1:1 & 1:3 Octave Band Filters
CR:832B	Type 2 Broadband with 1:1 & 1:3 Octave Band Filters

The CR:800B Sound Level Meters meet the requirements for Type 1 and Type 2 Sound Level Meters according to IEC 60651 and 60804 depending upon the version of the instrument. They also meet the new IEC 61672-1:2003 standard for Class 1 Group X or Class 2 Group X Sound Level Meters as appropriate. Please refer to page 67 for full technical details of the CR:800B Sound Level Meters.

To meet the requirements of ANSI S1.4 for Random Incidence microphone response, an NK:70 Random Incidence Adaptor should be used when making measurements. Please refer to page 17 for details of the use of the NK:70 Random Incidence Adaptor.

## Messages and Symbols

Messages are used in this manual to bring important information to your attention. The different message types are indicated as shown below.



Pay attention! A caution informs you that improper use of the equipment or failure to follow instructions may cause data loss or may damage the equipment.



Please read. A note is a hint or advice that helps you make best use of the equipment and accessories.

---

## Section 1 Introduction

### Main Features

#### Measurement Functions

The measurement functions that can be provided by the CR:800B depend upon the options that have been fitted. If the instrument has been fitted with the 1:1 Octave Band or the 1:3 Octave Band filters, these measurements will be available.

Listed below is a summary of the measurements that can be provided by the basic Broadband instrument, and by the addition of the 1:1 Octave Band or the 1:3 Octave Band filters.

If the Auto Repeat function is used, the CR:800B can be made to repeat the broadband measurement up to 999 times. See page 21 for details of setting the auto repeat function. The instrument can also be configured to synchronise the measurement start time with the instrument clock. See page 21 for details of the Auto Synchronise function.

#### Broadband Measurement Mode

In Broadband Mode, the instrument stored the overall values such as  $L_{Aeq}$ ,  $L_{AFmax}$  and  $L_n$ 's as well as storing a noise profile, or Time History, during each measurement.

The CR:800B instruments can store up to 1,300 Broadband Measurements which can be of any length, up to a maximum of 99 hours per measurement. With each measurement is stored a noise profile which consists of 1 second  $L_{eq}$  samples, with up to a maximum of 11 days of Noise Profile being available. Please refer to the Specifications on page 67 for full details of the available memory.

Function	Frequency Weighting	Displayed as	Maximum value	Minimum value
Sound Level with Fast Time Weighting	A	$L_{AF}$	$L_{AFmax}$	$L_{AFmin}$
	C	$L_{CF}$	$L_{CFmax}$	$L_{CFmin}$
	Z	$L_{ZF}$	$L_{ZFmax}$	$L_{ZFmin}$
Sound Level with Slow Time Weighting	A	$L_{AS}$	$L_{ASmax}$	$L_{ASmin}$
	C	$L_{CS}$	$L_{CSmax}$	$L_{CSmin}$
	Z	$L_{ZS}$	$L_{ZSmax}$	$L_{ZSmin}$
Sound Level with Impulse Time Weighting	A	$L_{AI}$	$L_{AImax}$	$L_{AImin}$
	C	$L_{CI}$	$L_{CImax}$	$L_{CImin}$
	Z	$L_{ZI}$	$L_{ZImax}$	$L_{ZImin}$
Equivalent Continuous Sound Pressure Level with integration time t	A	$L_{Aeqt}$	-	-
	C	$L_{Ceqt}$	-	-
	Z	$L_{Zeqt}$	-	-
Sound Exposure Level (SEL)	A	$L_{AE}$	-	-
	C	$L_{CE}$	-	-
	Z	$L_{ZE}$	-	-
Peak Sound Pressure	C	$L_{Cpeak}$	-	-
Takt Maximum Sound Level DIN 45641 ( $L_{AFTeq}$ )	A	$L_{AFTeq}$	-	-
Impulse Weighted Equivalent Sounds Press Level with integration time t ( $L_{Ieqt}$ )	A	$L_{AIeqt}$	-	-
	C	$L_{CIeqt}$	-	-
	Z	$L_{ZIeqt}$	-	-

Please note that only one Frequency Weighting can be selected at any time.

### 1:1 & 1:3 Octave Band Measurement Mode

In the 1:1 or 1:3 Octave Band Filter Mode, the CR:800B instrument provide a sequential sweep through the filter bands over the measurement duration. In addition to the frequency bands, the instruments also provide a measurement of the overall  $L_{Aeq}$ ,  $L_{Ceq}$  and  $L_{Zeq}$  functions.

Function	Frequency Weighting	Displayed as	Stored Measurement	Applies to
Sound Level with Fast Time Weighting	Z	LZF	No	1:1 & 1:3 Octave Bands
Equivalent Continuous Sound Pressure Level with integration time t	Z	LZeqt	Yes	1:1 & 1:3 Octave Bands
	A	LAeqt	Yes	Broadband
	C	LCeqt	Yes	Broadband
	Z	LZeqt	Yes	Broadband

The 1:1 Octave Band Filters cover the following frequency bands: 31.5Hz to 16kHz

The 1:3 Octave Band Filters cover the following frequency bands: 25Hz to 16kHz

When the MO:800/6 Options is fitted, the 1:3 Octave Band Filters include the additional 20Hz and 20kHz 1:3 Octave Band Filters.

### Options & Accessories

The CR:800B Series are also available with a range of options and accessories that can enhance the performance and applications of the instrument. For full details, please contact Cirrus Research plc or your local representative.

The most commonly used accessories are listed below.

CR:511E	Acoustic Calibrator
CR:511F	Acoustic Calibrator with PTB Type Approval
CR:512	Class 1 Acoustic Calibrator
CR:590	Barometer for use with CR:511F Acoustic Calibrator
UA:237	Windshield
CK:250	Carrying Case
CP:65	Carrying Pouch for Sound Level Meter
CT:1	Tripod
CM:270/1	Preamplifier Tripod Mount
ZL:202	2m Microphone Extension Cable
ZL:205	5m Microphone Extension Cable
ZL:210	10m Microphone Extension Cable
ZL:225	25m Microphone Extension Cable
CK:408	Outdoor Measurement Kit
CK:508	Lightweight Outdoor Measurement Kit
CU:195A	Mains Power Supply (UK/US/EU)
SW:DD3	Deaf Defier3 Software
ZL:803	Printer Cable for Serial Printer
ZL:804	AC Output Cable to BNC Connector 2m
ZL:806	12v Power Cable for CR:800B & CR:800B Series 2m
ZL:807	2m AC Output Cable to BNC



---

## Section 2 Getting Started

### How to...

These example settings are designed to demonstrate the different configurations that are available from the CR:800B Sound Level Meters. Please check the configuration of the instrument to match the measurement requirements of your application before making a measurement.

#### **Make a 15 minute Broadband Measurement**

1. Switch on
2. Calibrate
3. Set Measurement Mode to Broadband
4. Set measurement duration to 15 minutes
5. Switch off Auto Repeat & Auto Synchronise
6. Set Measurement Range
7. Start Measurement
  - a. Run for 15 minutes
8. Stop Measurement
9. Review Measurement Data

#### **Make a 1:1 Octave Band Measurement over 1 minute**

1. Switch on
2. Calibrate
3. Set Measurement Mode to 1:1 Octave Band
4. Set Measurement Duration to 1 minute
5. Set Measurement Range
6. Start Measurement
  - a. Run for 1 minute
7. Stop Measurement
8. Review Measurement Data

#### **Make a 1:3 Octave Band Measurement over 5 minutes**

1. Switch on
2. Calibrate
3. Set Measurement Mode to 1:3 Octave Band
4. Set Measurement Duration to 5 minutes
5. Set Measurement Range
6. Start Measurement
  - a. Run for 5 minutes
7. Stop Measurement
8. Review Measurement Data

#### **Make a set of twenty four 1 hour measurements**

1. Switch on
  2. Calibrate
  3. Set Measurement Mode to Broadband
  4. Set Measurement Duration to 1 hour
  5. Set Auto Repeat to On
  6. Set Number to 25
  7. Set Auto Synchronise to On
    - a. Start Measurement
  8. After 24 1 hour measurements the instrument will stop
  9. Review Measurement Data
-

## Quick Start

### Switch on

Key Press

Display

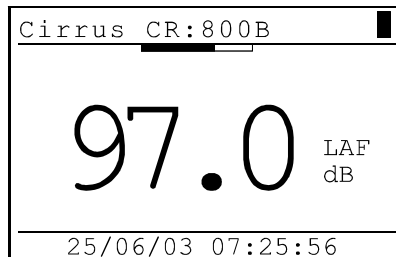

When the instrument has switched on, the start-up screen will change to the standard noise level display.

### Calibrate the Sound Level Meter



If a microphone extension cable is to be used during a measurement, the instrument must be calibrated with the cable attached.

Connect the Acoustic Calibrator to the Sound Level Meter and select the 94dB setting on the Acoustic Calibrator. Press the Menu key to select the Calibrate option and press OK to start the calibration procedure.

Key Press

Display

Comments

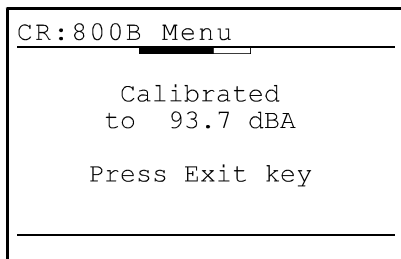
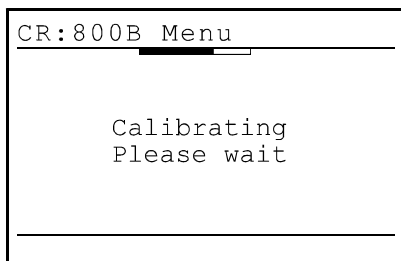
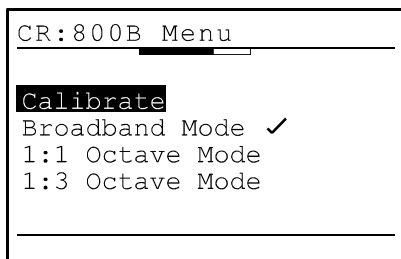

If the calibration is successful, press the exit key to return to the main screen.

### Set the measurement duration

Press the menu key to view the current measurement duration and the status of the auto repeat and auto synchronise function. At the bottom of the screen is the current configuration.

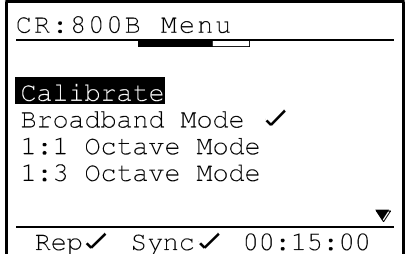
Key Press	Display	Comments
		<p>In this example, the measurement duration is set to 15 minutes.</p> <p>The Auto-Repeat function is switched on.</p> <p>The Auto-Synchronise function is switched on.</p>

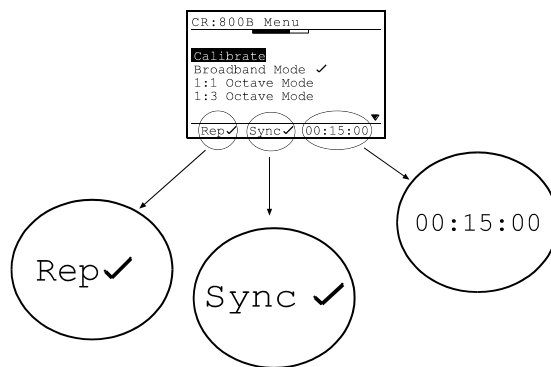

If the measurement duration is not as required, use the Measurement Duration menu option to set the required measurement duration. Refer to page 31 for details of setting the measurement duration.

### Check the measurement range

Press the Range key to check the current measurement range.

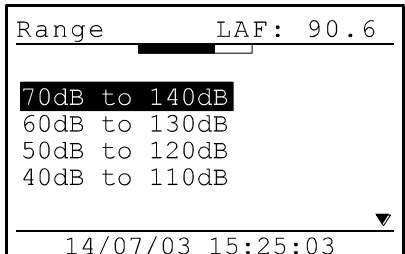
Key Press	Display	Comments
		In this example, the measurement range is set to 70dB to 140dB.

To change the measurement range, use the Up and Down Arrow keys to select the required measurement range and press OK.

Refer to page 35 for details of setting the measurement range and the use of the bar graph display in choosing the correct measurement range.

### Change the measurement function

To check the current measurement function and to change the measurement function, press the menu key. Use the Up and Down arrows keys to select the required measurement mode and OK to Select the mode required.

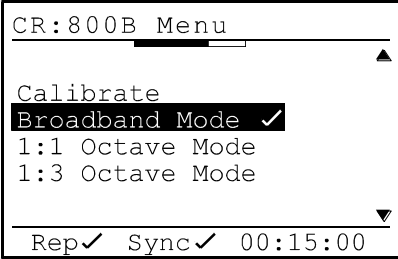
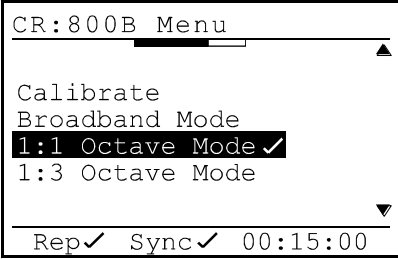
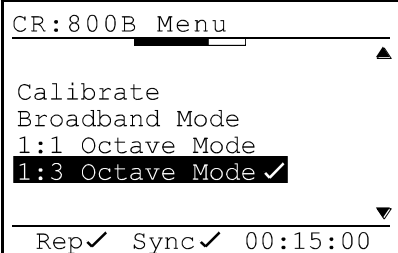
Key Press	Display	Comments
		In this example, the instrument is set to Broadband Measurement Mode
		
		

### Start & Stop the measurement

To start the measurement, press the Start Key

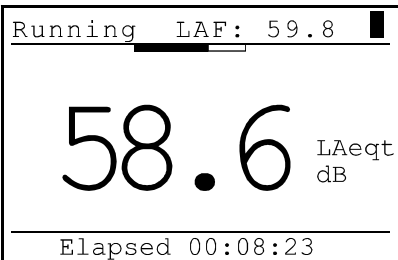
Key Press	Display	Comments
		

Press the Up and Down arrow keys to view the measurement functions during the measurement.

To stop the measurement, press the Stop Key.

Key Press	Display	Comments												
	<table border="1"><tr><td>Mem 10</td><td>Broadband</td></tr><tr><td>Elapsed</td><td>00:15:00</td></tr><tr><td>LAeqt</td><td>53.5 dB</td></tr><tr><td>LCpeak</td><td>95.0 dB</td></tr><tr><td>LAE</td><td>82.9 dB</td></tr><tr><td colspan="2">30/06/03 11:12:07</td></tr></table>	Mem 10	Broadband	Elapsed	00:15:00	LAeqt	53.5 dB	LCpeak	95.0 dB	LAE	82.9 dB	30/06/03 11:12:07		The instrument stores the measurement in memory and enters the measurement review mode.
Mem 10	Broadband													
Elapsed	00:15:00													
LAeqt	53.5 dB													
LCpeak	95.0 dB													
LAE	82.9 dB													
30/06/03 11:12:07														

### Review the measurement

When the measurement has been stopped, the instrument automatically stores the measurement in memory and enters the measurement review mode. Use the Up and Down arrow keys to view the different measurement values and press the exit key to return to the main display.

Refer to page 44 for details of the measurement review mode.

## Unpacking and checking the Sound Level Meter

Carefully remove the instrument from its shipping container and inspect it for possible damage or missing items. If the meter appears to be damaged or something is missing, contact Cirrus Research plc or your local representative immediately.

The basic CR:800B instrument is supplied with the following standard accessories:

- Deaf Defier3 for Windows Software on CD-ROM
- CR:800B User Manual
- CR:800B Reference Card
- ZL:800 RS232 Cable
- Batteries 2 x AA

In addition, the Type 1 versions of the instrument are supplied with an MV:200C Preamplifier and a microphone box. The microphone capsule will be fitted to the MV:200C Preamplifier before shipping.

If you have ordered the instrument as a complete measurement kit, you will have also received some further items such as an Acoustic Calibrator, Carrying Case and Windshield.

Please refer **Error! Reference source not found.** for details of fitting the battery and operation of this unit.

## Installing the software

Before measurements can be downloaded from the CR:800B instrument, the Deaf Defier3 software must be installed from the supplied CD.

Please refer to page 49 for further details of the installation of the Deaf Defier3 software.

## Assembly

The CR:800B instruments are supplied fully assembled apart from the MV:200C Preamplifier for Type 1 instruments and the batteries.

## Preamplifier

The Type 1 versions of the CR:800B (CR:811B, CR:821B and CR:831B) are supplied with a removable preamplifier, the MV:200C. Also, a removable preamplifier may be fitted as an option to the Type 2 instruments.

This preamplifier must be connected to the Sound Level Meter **before** the unit is switched on. This unit is connected to the top of the CR:800B using a locking ring. To connect the MV:200C Preamplifier, follow the diagram below:

---



- (1) Drop the preamplifier into the socket on the Sound Level Meter
- (2) Ensure the connector has located into the socket
- (3) Tighten the Locking Ring.



**Do not** cross thread the locking ring. Damage caused by misuse is not covered by the warranty for the instrument.

### Removing the Preamplifier

**Do not** twist the preamplifier body. Unscrew the locking ring and pull the preamplifier from the Sound Level Meter.

## Using Microphone Extension Cables

The CR:800B instruments can be used with a microphone extension cable if the instrument is fitted with the removable preamplifier. If a microphone extension cable is to be used during a measurement, the instrument must be calibrated with the cable attached.

Connect the microphone extension cable in the same manner as the MV:200C Preamplifier.

## Batteries

The batteries of the CR:800B are located behind the cover on the bottom of the instrument. Slide the cover to the right hand side to remove and to access the battery holder.

Ensure the instrument is switched off. Remove the battery holder from the instrument and insert the batteries. The CR:800B instruments uses two AA type batteries, also known as LR6.

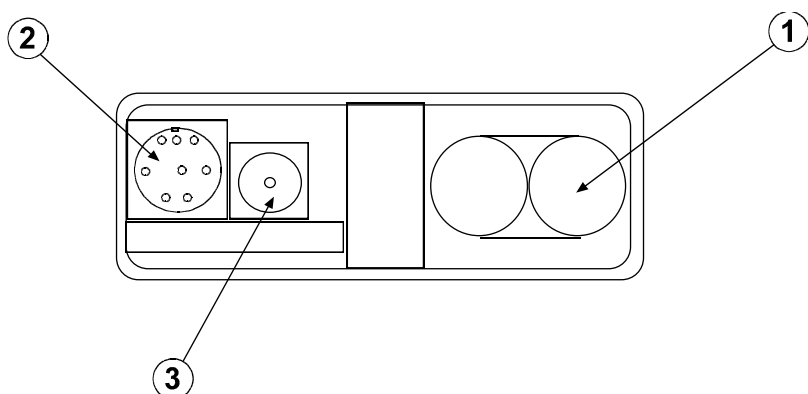

- (1) Batteries
- (2) RS232 Communications Socket
- (3) External Power



Ensure that the batteries are inserted correctly. **DO NOT** reverse the polarity of the batteries as this may cause damage to the instrument.



## Using an external power supply

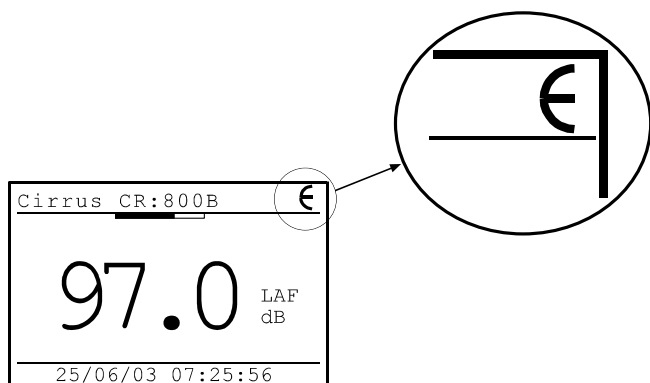

The CR:800B can be used with an external power supply. When the external supply is connected, the CR:800B switches automatically from the internal battery power. When the external power is either removed or switched off, the instrument will automatically switch back to the internal battery supply.

When an external supply is connected, the display of the instrument will show a symbol in the top right corner as shown below.

## Windshield

The CR:800B Series can be used with a UA:237 90mm Foam Windshield which will reduce the noise levels generated by air turbulence over the microphone capsule.

The windshield can also be used to protect the microphone capsule of the Sound Level Meter from dust and fluids which may affect the performance of the instrument. To use the UA:237 Windshield, push the hole in the windshield over the microphone of the Sound Level Meter. The UA:237 Windshield must be removed before the Sound Level Meter can be calibrated.

## NK:70 Random Incidence Adaptor

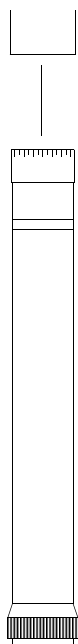

The NK:70 Random Incidence Adaptor is designed to modify the response of the microphone capsule from Free Field to Random Incidence in order to comply with the requirements of ANSI S1.4.

For instruments supplied for use outside of the USA, this adaptor may not be supplied. For further details, please contact your local representative or Cirrus Research plc.

To fit the NK:70 Random Incidence Adaptor, push the adaptor over the microphone grill. Do not attempt to remove the microphone grill as this may cause damage to the capsule.

To calibrate the instrument fitted with the microphone capsule, remove the NK:70 Adaptor and follow the instructions supplied with the instrument. Do Not attempt to calibrate the instrument with the NK:70 fitted.

## Switching On

Key Press

Display

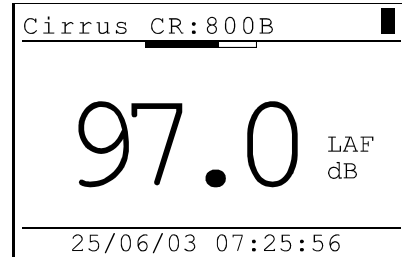
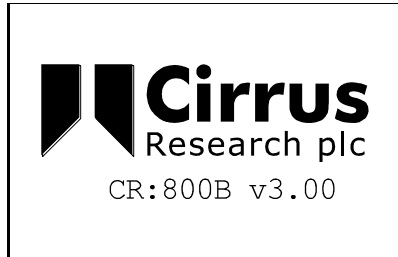

When the instrument is first switched on, a Welcome screen is shown with the instrument type and version number. After 3 seconds, the display will change and the current Sound Level will be shown with the current configuration shown as above.

In this example, the instrument is showing the Fast A-Weighted Sound Level with the current Date and Time shown at the bottom of the screen. The battery level is shown in the top right hand corner of the display.

Across the top of the display, above the numbers, is shown the sound level as a bar graph. This graph is scaled with the current measurement range. Please refer to page 35 for details of changing the measurement range.

The display will also show the battery level and when the instrument is in Overload or Under Range. The Glossary on page 56 also describes the indication of Overload and Under Range.

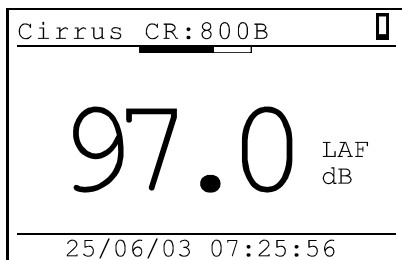

Low Battery Level

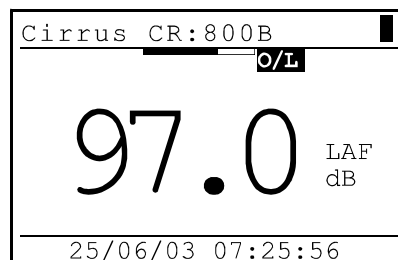

Overload

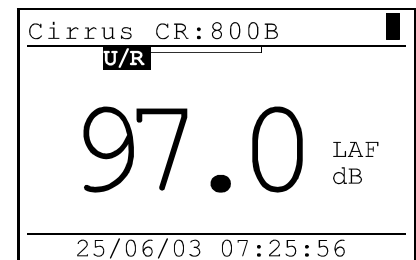

Under Range

## Checking the Configuration of the Instrument

The Setup of the instrument should be checked before making a measurement.

### Time and Date

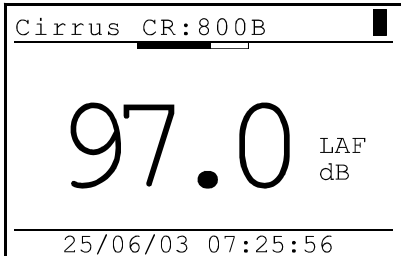
Key Press	Display	Comments
		The current time and date are shown at the bottom of the screen.

### Measurement Range

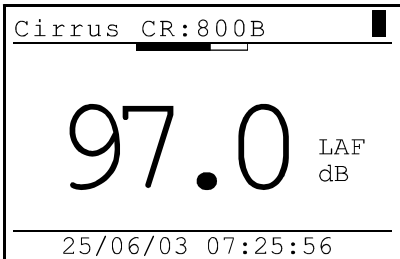
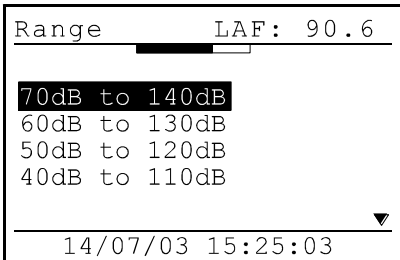
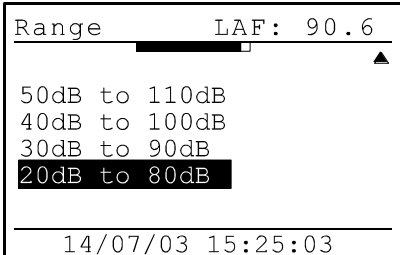
Key Press	Display	Comments
		
Range		The current measurement range is shown highlighted. Use the Up and Down Arrows to change the range.
		Press the OK key to change the range or Exit to discard.  The bar at the top of the screen shows the noise level in proportion to the measurement range.

### Measurement Mode

Key Press      Display      Comments

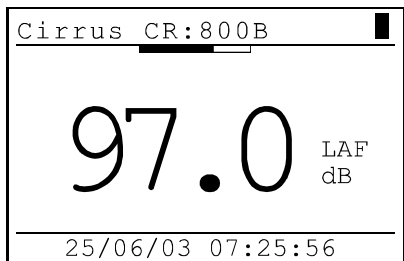

Menu

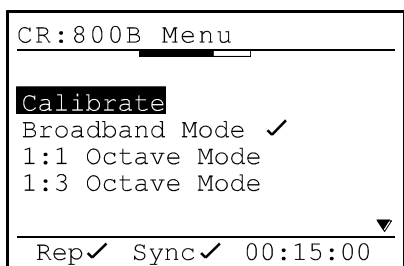

The current measurement mode is shown on the screen.

In this example, the measurement mode is Broadband.

### Measurement Duration

Key Press      Display      Comments

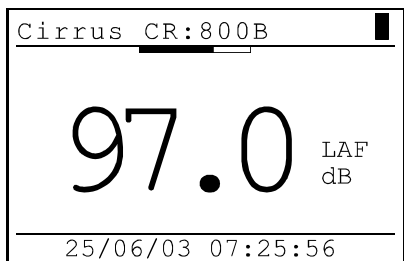

Menu

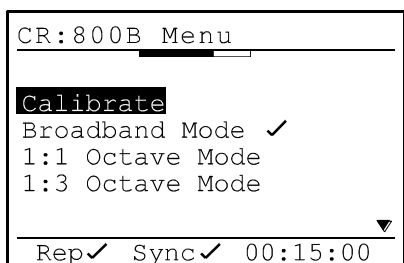

The measurement duration is shown at the bottom of the screen.

In this example, the measurement time is 15 minutes.

When the instrument is set to either 1:1 or 1:3 Octave Band Mode, the Run Duration is divided between the frequency bands. For example, if the measurement duration is set to 15 minutes, the CR:800B instrument will take a **total** of 15 minutes to complete the sweep through the frequency bands.

To meet the accuracy required by the standards to which the instrument is designed to meet, there is a minimum time required to measure each frequency band. Therefore, the CR:800B enforces a minimum measurement duration of 1 minute for the 1:1 Octave Band Mode and 3 minutes for the 1:3 Octave Band Mode.

## Measurement Auto Repeat

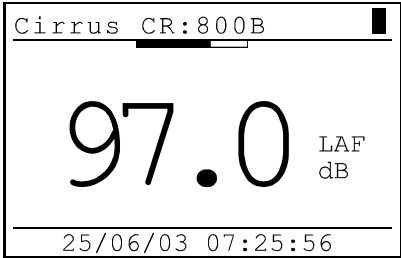
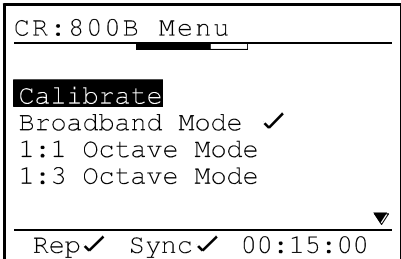
Key Press	Display	Comments
		
Menu		<p>The status of the Auto Repeat is shown at the bottom of the screen.</p> <p>In this example, the Auto Repeat is switched on.</p> <p>When the Auto Repeat is switched off, the display is Repx</p>

## Measurement Auto Synchronise

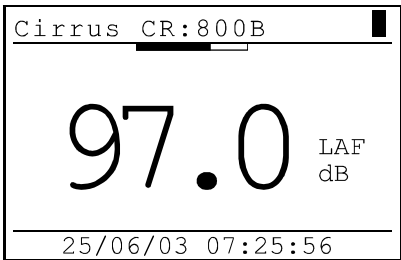
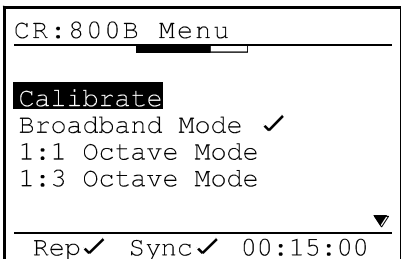
Key Press	Display	Comments
		
Menu		<p>The status of the Auto Synchronise is shown at the bottom of the screen.</p> <p>In this example, the Auto Synchronise is switched on.</p> <p>When the Auto Synchronise is switched off, the display is Syncx</p>

## Configuring the instrument from the Deaf Defier3 software

The entire configuration of the instrument can be set from the Deaf Defier3 software using the Advanced Configuration option. Please refer to page 80 for details of this function.

## Calibration

If a microphone extension cable is to be used during a measurement, the instrument must be calibrated with the cable attached.

Attach the Acoustic Calibrator to the Sound Level Meter, and press the menu key. The first menu option is Calibrate.

Key Press

Display

Comments



```

CR:800B Menu
-----
Calibrate
Broadband Mode ✓
1:1 Octave Mode
1:3 Octave Mode
-----
Rep✓ Sync✓ 00:15:00
  
```

Select 94dB on the Acoustic Calibrator before starting the calibration procedure.

```

CR:800B Menu
-----
Calibrating
Please wait
-----
  
```

```

CR:800B Menu
-----
Calibrated
to 93.7 dBA
Press Exit key
-----
  
```

If the calibration is successful, the instrument will display the calibration information screen.

Press Exit to return to the main screen.

If the instrument cannot calibrate successfully, the display will show an error:

```

CR:800B Menu
-----
Too Low
Not Calibrated
Press Exit key
-----
  
```

The calibration level is too low.

The Calibrator may not be switched on or may not be functioning correctly.

```

CR:800B Menu
-----
Too High
Not Calibrated
Press Exit key
-----
  
```

The calibration level is too high.

Check that the calibration level on the Acoustic Calibrator is set to the correct level.

The default level is 94dB

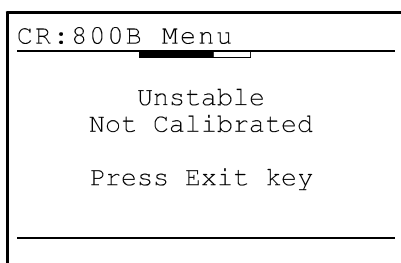

The calibration level is unstable.

The background noise level may be too high or the Acoustic Calibrator may not be fitted correctly to the Sound Level Meter.

Refer to the troubleshooting section on page 54 for further information.

## Starting a measurement

### Broadband Mode

Key Press

Display

Comments

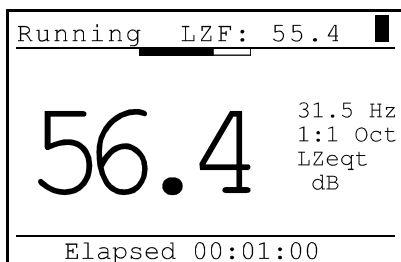

When the measurement is running, the display shows "Running" in the top left hand corner.

If the user does not stop or reset the measurement, the instrument will run for the preset measurement duration. At the end of the measurement, the information will be automatically stored in the memory.

If the Auto-Repeat function is enabled, the next measurement will start automatically at the end of the previous measurement.

### 1:1 Octave Band Mode

Key Press

Display

Comments

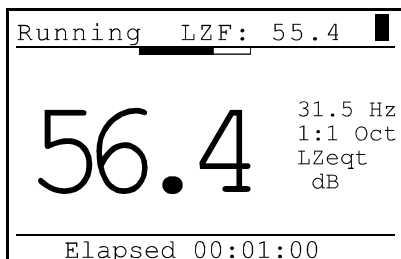

When the measurement is running, the display shows "Running" in the top left hand corner.

If the measurement duration is set to Manual, the 1:1 Octave Band frequency will stay on the current frequency until the Up arrow is pressed. At the end of the measurement, the user must press the Stop key to end the measurement and store the information in the memory.

When the measurement duration is set to any option other than Manual, the instrument will automatically sweep through the 1:1 Octave Bands in the set duration. After the

16kHz 1:1 Octave Band, the instrument will measure a dB(A), dB(C) and then a dB(Z) value and then stop, storing the measurement in the memory.

The user can override the automatic sweep by pressing the Up arrow key to step to the next frequency band.

The display will show ---- until enough data has been accumulated to give an accurate measurement.

Key Press

Display

Comments

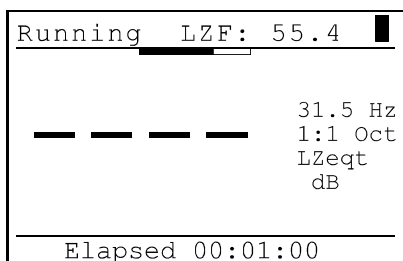

The instrument has not accumulated sufficient data to give an accurate measurement.

When enough information has been gathered, the LZeqt value will be displayed.

### 1:3 Octave Band Mode

Key Press

Display

Comments

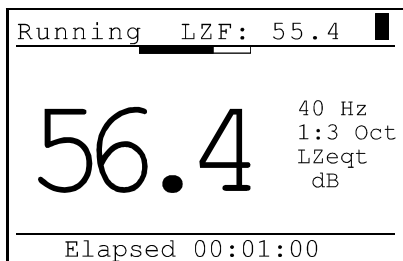

When the measurement is running, the display shows "Running" in the top left hand corner.

If the measurement duration is set to Manual, the 1:3 Octave Band frequency will stay on the current frequency until the Up arrow is pressed. At the end of the measurement, the user must press the Stop key to end the measurement and store the information in the memory.

When the measurement duration is set to any option other than Manual, the instrument will automatically sweep through the 1:3 Octave Bands in the set duration. After the 16kHz 1:3 Octave Band, the instrument will measure a dB(A), dB(C) and then a dB(Z) value and then stop, storing the measurement in the memory.

The user can override the automatic sweep by pressing the Up arrow key to step to the next frequency band.

The display will show ---- until enough data has been accumulated to give an accurate measurement.

Key Press

Display

Comments



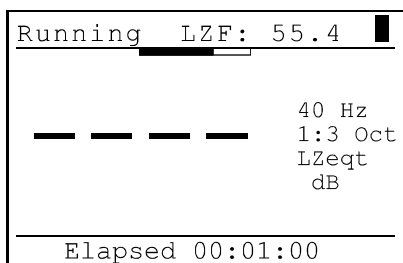

The instrument has not accumulated sufficient data to give an accurate measurement.

When enough information has been gathered, the LZeq value will be displayed.

## Displaying the data during a measurement

### Broadband Mode

During a Broadband Mode measurement, the user can step through the different measurement parameters. All of the functions are measured simultaneously and are automatically stored. Please note that this function is only available in Broadband Mode.

Key Press      Display

Comments

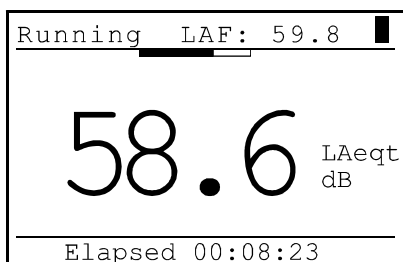

The instrument starts with the LAeq,t value and the Elapsed Time.

The Sound Level, in this case LAF, is shown in the top right hand corner of the screen.

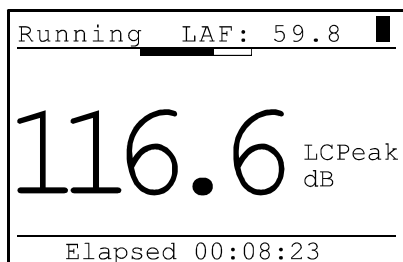

The Peak(C) value is shown

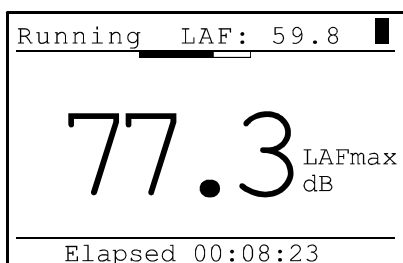

The Maximum Sound Level, LAFmax in this example, is shown

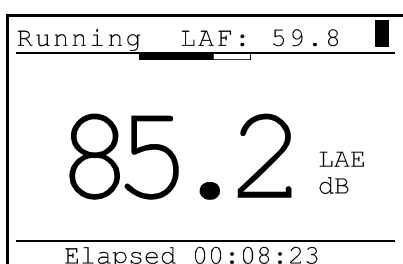

The Sound Exposure Level, or LAE is shown.

If the User Metric is configured for either the LAFteq or LIEq,t functions, these will be shown instead of the LAE value.

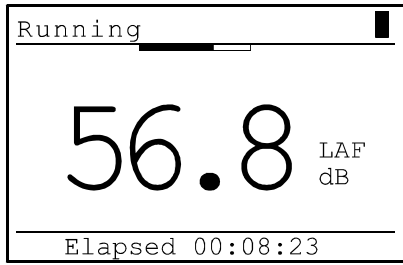

The Sound Level is shown, in this case the LAF.

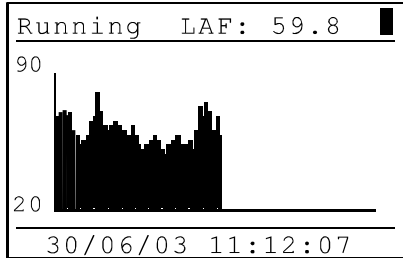

The real time display of the noise level is shown as 1 second Leq samples.

The display shows 2 minutes of information and then starts to scroll across the screen.

### Pausing and Resetting a measurement

During a measurement, the user can pause the measurement by pressing the Start/Pause key.

Key Press

Display

Comments

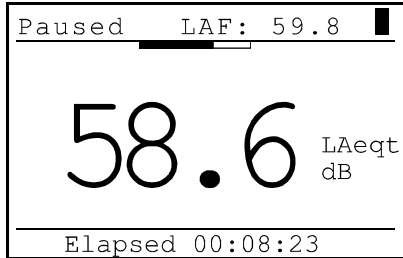

The measurement is paused.

To restart the measurement, press the Start/Pause key again.



When a Broadband measurement is paused, the collection of data for the overall parameters, such as the Leq, is paused. However, the Time History measurement continues and the instrument codes this data. When the information is downloaded to the Deaf Defier3 software, the user can see when the measurement was paused.

Information recorded by the Time History store when the instrument is in pause mode is not used in the calculation of the overall parameters.



The user can reset and discard the current measurement when the instrument is running by pressing the Reset key. This will delete the current measurement information and restart the measurement.

### Stopping the measurement

At any time during a measurement, the user can stop the measurement. The data will be automatically stored in memory, and the display will change to the memory review mode.

Key Press      Display      Comments

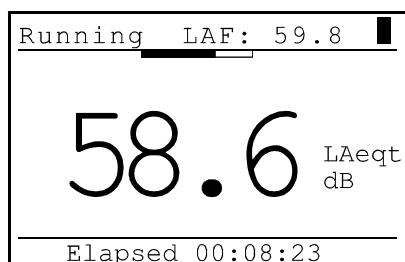

```
Running LAF: 59.8
58.6 LAeqt dB
Elapsed 00:08:23
```

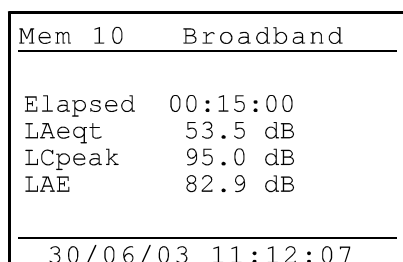
```
Mem 10 Broadband
Elapsed 00:15:00
LAeqt 53.5 dB
LCpeak 95.0 dB
LAE 82.9 dB
30/06/03 11:12:07
```

When the Stop key is pressed, the current measurement is stored in the memory and the display changes to the memory review mode.

In this example, the measurement is a Broadband measurement.

## Viewing the stored measurements

### After a measurement has been stopped

When the measurement is stopped, the data is automatically stored in memory and the instrument enters the measurement review mode.

Use the Up and Down arrow keys to review the measurement data. Refer to page 44 for details of reviewing measurements.

### Recalling stored measurements

Measurements can be recalled at any time to the instrument display. Refer to page 44 for details of recalling measurements.

## Section 3 Configuring the Sound Level Meter

This section of the manual covers the configuration of the Sound Level Meter and the different options that are available to the user.

### Keypad

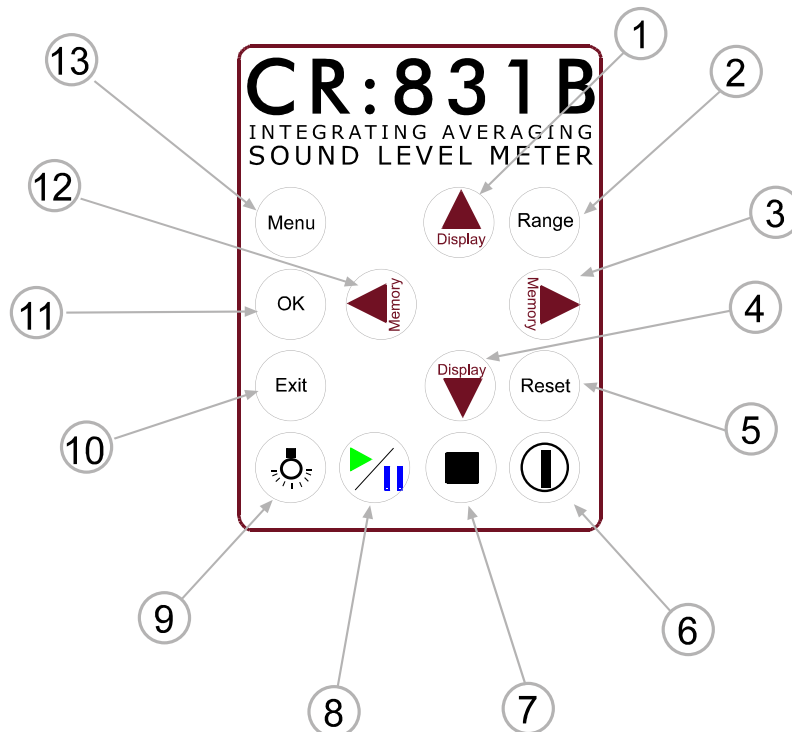

- (1) Move through the measurement parameters when running a measurement. Move through the stored measurement parameters in memory recall mode. Select a higher frequency band in 1:1 and 1:3 Octave Band Filter mode. Step up through menu options
- (2) Change the measurement range and display the current measurement range
- (3) Enter Memory Recall Mode and step through the memory locations
- (4) Move through the measurement parameters when running a measurement. Move through the stored measurement parameters in memory recall mode. Select a lower frequency band in 1:1 and 1:3 Octave Band Filter mode. Step down through menu options
- (5) Resets the current measurement when running
- (6) Power On and Off
- (7) Stops the current measurement when running
- (8) Start and Pause a measurement
- (9) Switch on and off the display backlight
- (10) Exit menu option. Cancel data entry
- (11) Select menu option. Accept data entry
- (12) Enter Memory Recall Mode and step through the memory locations
- (13) Select the menu mode and view the menu options

### Menu System

The CR:800B instruments use a menu system to allow the user to change the operation of the Sound Level Meter. This menu system is described below along with the procedure to change the different measurement functions and operational parameters.

## Measurement Mode

To select the Measurement Mode, press the Menu Key. The current measurement mode is displayed. Please note that the CR:800B Sound Level Meters will revert to Broadband Measurement Mode when the instrument is switched off.

Key Press

Display

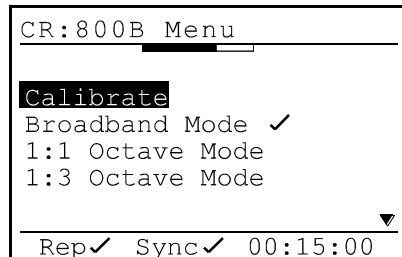

## Broadband Mode

To select the Broadband Measurement Mode:

Key Press

Display

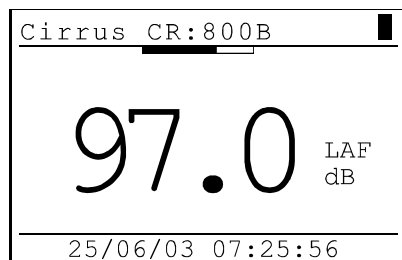
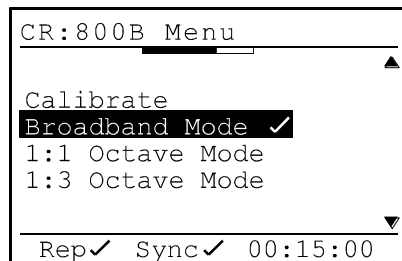



### 1:1 Octave Band Mode

To select the 1:1 Octave Band Measurement Mode:

Key Press

Display



<p>Display</p>  <p>OK</p>   <p>Exit</p> 	<div style="border: 1px solid black; padding: 5px; margin-bottom: 10px;"> <p>CR:800B Menu</p> <hr/> <p>Calibrate</p> <p>Broadband Mode</p> <p><b>1:1 Octave Mode ✓</b></p> <p>1:3 Octave Mode</p> <hr/> <p>Rep✓ Sync✓ 00:15:00</p> </div> <div style="border: 1px solid black; padding: 5px;"> <p>Cirrus CR:800B</p> <hr/> <p style="font-size: 2em; font-weight: bold;">56.4</p> <p style="text-align: right;">31.5 Hz 1:1 Oct LZF dB</p> <hr/> <p style="text-align: center;">02/07/03 14:53:20</p> </div>
---------------------------------------------------------------------------------------------------------------------------------------------------------------------------------------------------------------------------------------------------------------------------------------------------	--------------------------------------------------------------------------------------------------------------------------------------------------------------------------------------------------------------------------------------------------------------------------------------------------------------------------------------------------------------------------------------------------------------------------------------------------------------------------------------------------------------------------

### 1:3 Octave Band Mode

To select the 1:1 Octave Band Measurement Mode:

Key Press

Display

<p>Display</p>  <p>OK</p>   <p>Exit</p> 	<div style="border: 1px solid black; padding: 5px; margin-bottom: 10px;"> <p>CR:800B Menu</p> <hr/> <p>Calibrate</p> <p>Broadband Mode</p> <p>1:1 Octave Mode</p> <p><b>1:3 Octave Mode ✓</b></p> <hr/> <p>Rep✓ Sync✓ 00:15:00</p> </div> <div style="border: 1px solid black; padding: 5px;"> <p>Cirrus CR:800B</p> <hr/> <p style="font-size: 2em; font-weight: bold;">56.4</p> <p style="text-align: right;">25 Hz 1:3 Oct LZF dB</p> <hr/> <p style="text-align: center;">02/07/03 14:53:20</p> </div>
---------------------------------------------------------------------------------------------------------------------------------------------------------------------------------------------------------------------------------------------------------------------------------------------------------	------------------------------------------------------------------------------------------------------------------------------------------------------------------------------------------------------------------------------------------------------------------------------------------------------------------------------------------------------------------------------------------------------------------------------------------------------------------------------------------------------------------------

### Measurement Duration

The configuration of the Run Duration, the Auto-Repeat and the Auto-Synchronise functions are all connected and affect each other.

Always ensure that the status of these three functions is checked before making a measurement. When the menu key is pressed, the display shows the status of these functions as shown below.

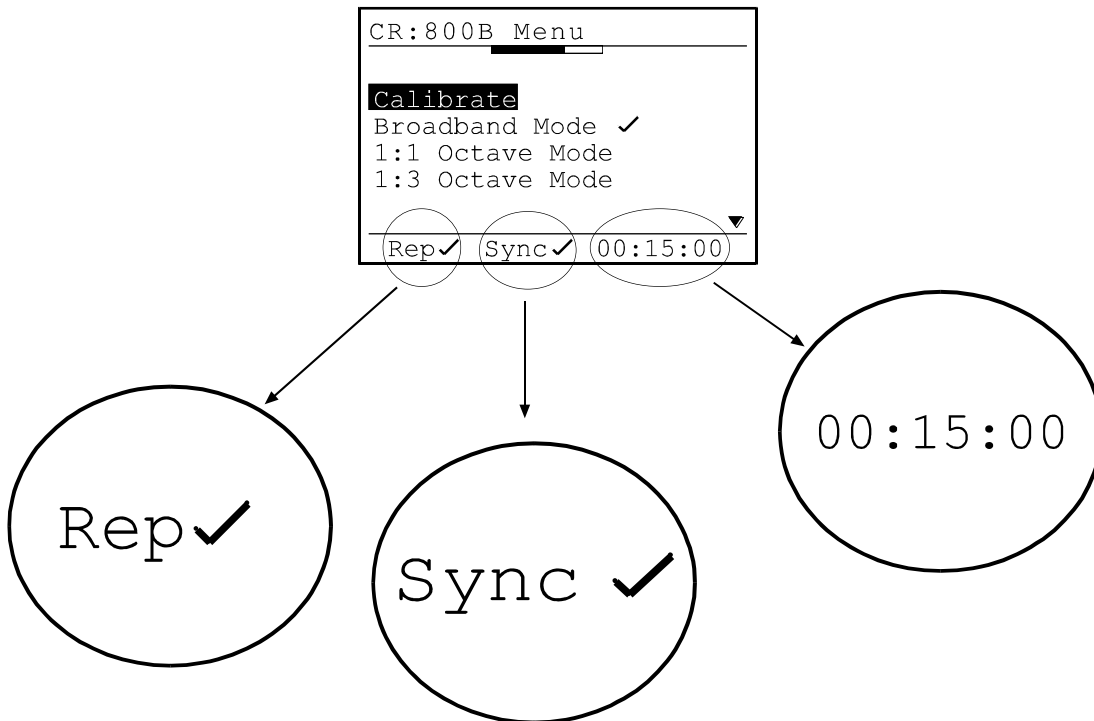

To change the measurement duration of the instrument:

Key Press

Display

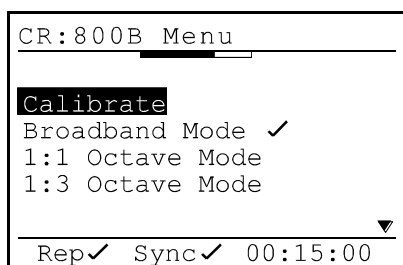

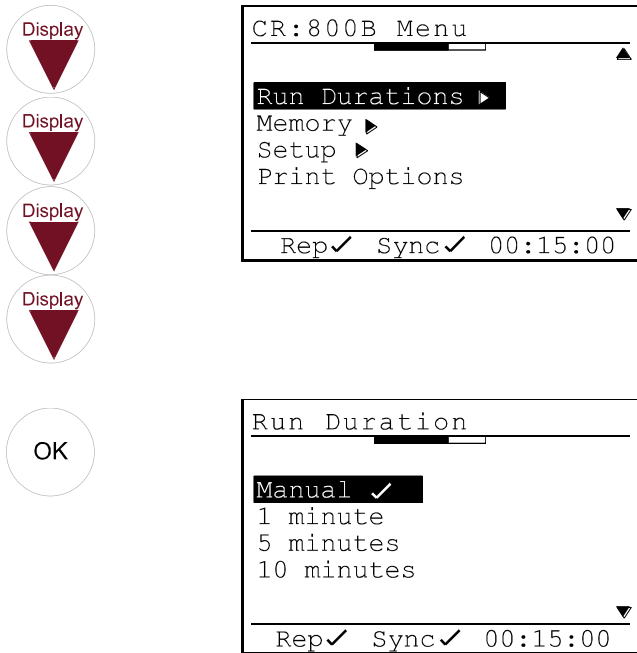

In this example, the measurement duration is set to 15 Minutes, and the instrument will run continuously until the Stop key is pressed. To change the measurement duration, use the Up and Down keys to select the required duration and press OK to select.

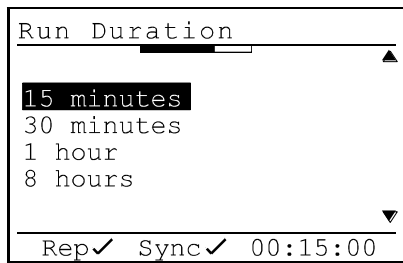

In addition to the preset measurement durations, the user can define the measurement duration using the Set User Time Option.

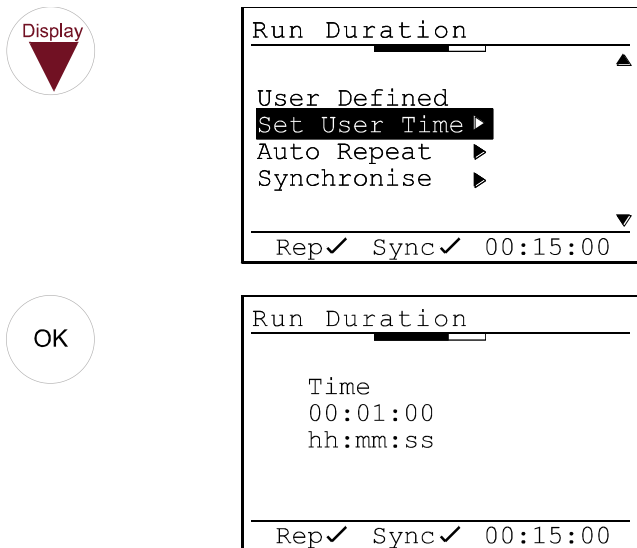

Use the Up and Down keys to change the parameter and the Left and Right keys to move through the different settings. Press OK to accept the User Time.

When the instrument is set to either 1:1 or 1:3 Octave Band Mode, the Run Duration is divided between the frequency bands. For example, if the measurement duration is set



to 15 minutes, the CR:800B instrument will take a **total** of 15 minutes to complete the sweep through the frequency bands.

To meet the accuracy required by the standards to which the instrument is designed to meet, there is a minimum time required to measure each frequency band. Therefore, the CR:800B enforces a minimum measurement duration of 1 minute for the 1:1 Octave Band Mode and 3 minutes for the 1:3 Octave Band Mode.

### Measurement Auto Repeat

The Auto Repeat function is used to set the instrument to make a series of contiguous measurements. Please note that this function only operated in the Broadband Measurement. Auto Repeat is not available during 1:1 or 1:3 Octave Band Mode.

For example, if the measurement duration was set to 15 minutes and the Auto Repeat disabled, after one 15 minute measurement the instrument will stop and store the measurement information the memory.

With the Auto Repeat function enabled, the instrument will make further 15 minute measurements, one after the next until the total number of measurements has been made. This allows the user to tell the instrument, for example, to make 96 individual 15 minute measurements over a 24 hour period.

To configure the Auto Repeat function, enter the menu and select the Measurement Duration option and then select the Auto Repeat option.

Key Press

Display

OK

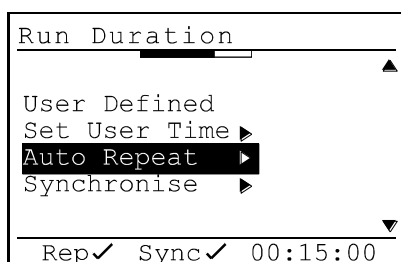

OK

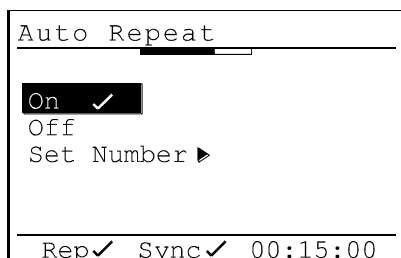

Use the up and down arrows to change the number of measurements required and the left and right arrows to move between the digits. Press OK to accept the changes or Exit to discard any changes made.

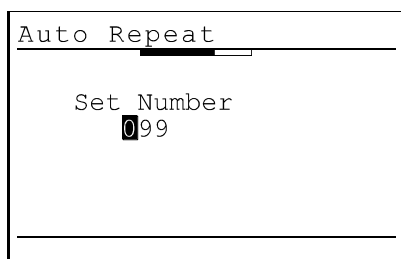

### Measurement Auto Synchronise

This function is new to the CR:800B Series and allows the start of the measurements to be started in time with the clock of the instrument.

The diagram below shows how the measurement runs from when the Start key is pressed for the duration defined by the Run Duration.

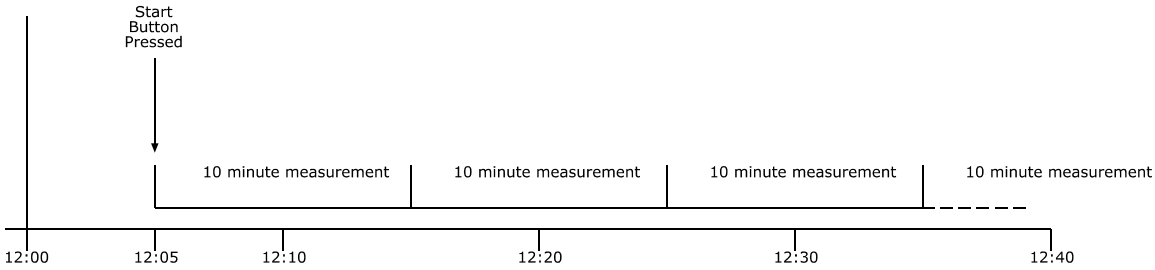

This method of starting and stopping the measurements is used, for example, when the application is Occupational Noise and the user wants to control the starting and stopping of the measurement directly.

However, in many applications such as Environmental Noise measurements, it is important to start the measurements at a predetermined time. For example, when making environmental noise measurements that are for 10 minutes, the CR:800B can be set to start the measurements on 10 minute boundaries.

The diagram below show the measurement starts with the Auto Sync function enabled.

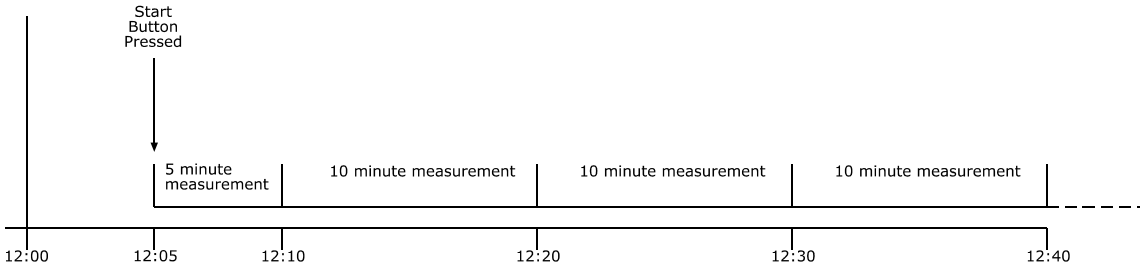

To enable the Auto Sync function, select the Run Duration option from the menu and then select the Synchronise function. Use the Up and Down arrows to switch on the off the Auto Synchronise function. Press Exit when finished.

Key Press

Display

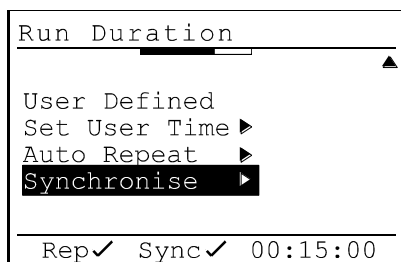

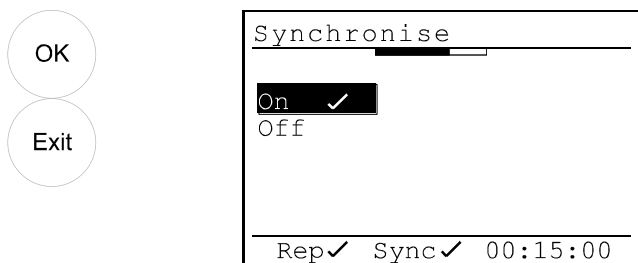

When the Auto Synchronise function has been selected, the display will show the Sync at the bottom of the screen with a tick next to it as shown above.

### Measurement Range

One of the most important features of a Sound Level Meter is the measurement range. If the measurement range is set too high, the instrument may not be able to record low levels. If the measurement range is set too low, high noise levels will overload the instrument and make the measurement invalid.

Therefore it is vital that the correct measurement range is chosen for the noise to be recorded.

To check the current measurement range, press the Range key.

Key Press	Display	Comments
-----------	---------	----------

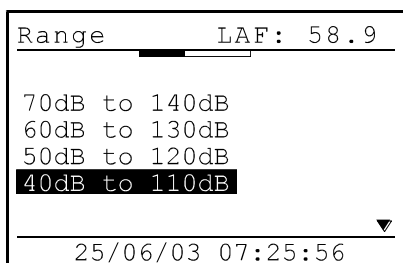
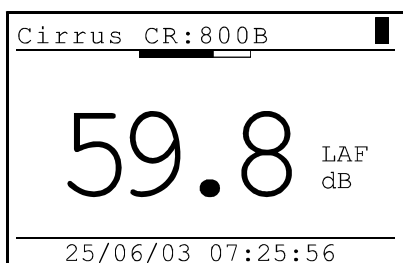

The current measurement range is 40dB to 110dB.

The measurement range in this example is 40dB to 110dB. If the noise level is below 40dB, the instrument will indicate Under-Range. If the noise level is above 110dB, the instrument will indicate Overload. See page 54 for an explanation of Overload and Under-Range.

Display	Comments
---------	----------

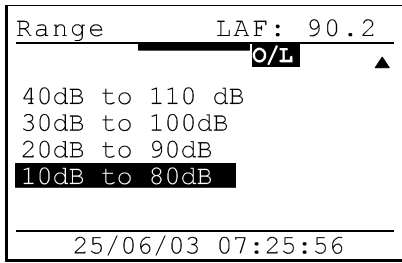

The measurement range is 10dB to 80dB and the noise level is 90.2dB.

The instrument is overloading and the O/L symbol is shown.

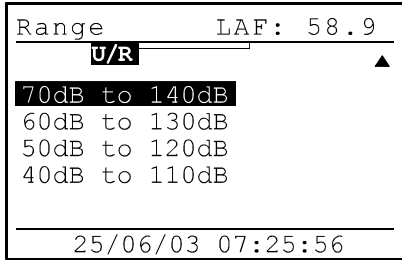

The measurement range is 70dB to 140dB and the noise level is 58.9dB.

The instrument is under ranging and the U/L symbol is shown.

The bar graph at the top of the screen can be used to select the appropriate measurement range. As the user moves between the different measurement ranges, the bar graph changes the top and bottom to match the measurement range. The noise level being measured is shown in the bar graph.

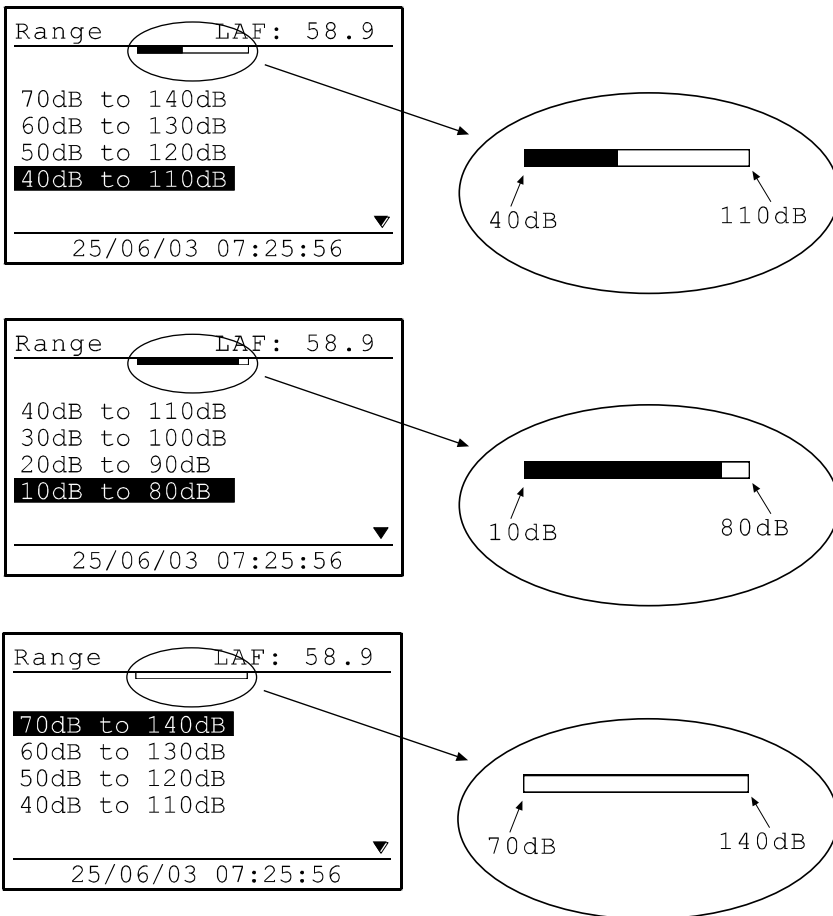

The diagram above shows how the bar graph will show where the noise level is placed within the selected measurement range. Select the appropriate measurement range to suit the noise levels to be measured.

## Instrument Setup

Select the Setup option from the main menu and press OK.

Key Press      Display      Comments

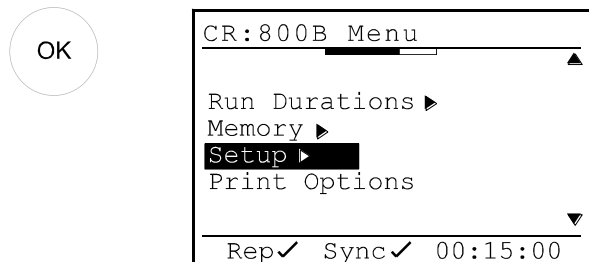

## Display Contrast

To adjust the contrast of the display, select the Contrast Option and press OK

Key Press      Display      Comments

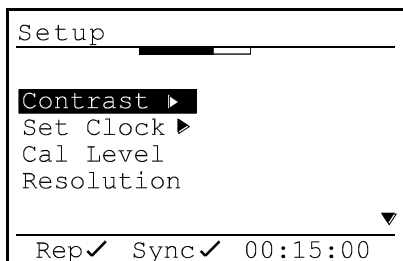

Select the Lighter or Darker option and press the OK repeatedly to adjust the selection.

Press the Exit button to exit from the Contrast menu.

## Time & Date

To change the Date and Time, select the Set Clock option from the Setup Menu.

Key Press

Display

Comments

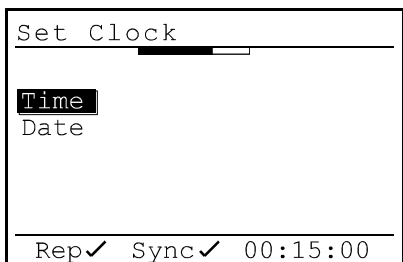
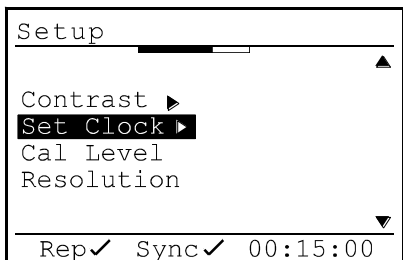

To set the Time, select the Time option and press OK

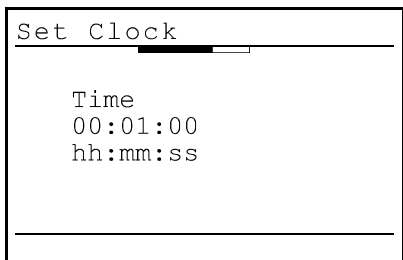

Use the Up and Down arrow keys to change the numbers and the left and right arrow keys to move between the numbers.

Press the OK key when the Time is correctly set.

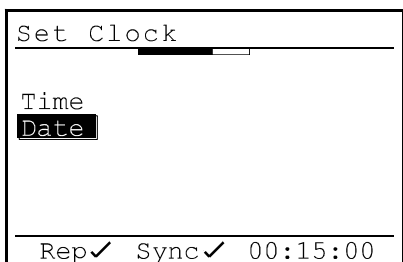

To set the Date, select the Date option and press OK

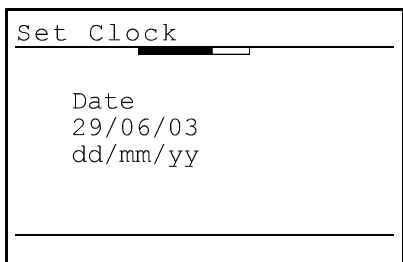

Use the Up and Down arrow keys to change the numbers and the left and right arrow keys to move between the numbers.

Press the OK key when the Time is correctly set.

## Calibration Level

The level at which the CR:800B instrument calibrates can be adjusted, if required, to suit different Acoustic Calibrators.

The default calibration level is 93.7dB for use with Cirrus Research plc CR:510 Series Acoustic Calibrators set to the 94dB setting. The correction of -0.3dB is required to suit the MK:224 and MK:216 Microphone capsules used by the CR:800B Series.

To adjust the calibration level, select the Cal Level option from the setup menu.

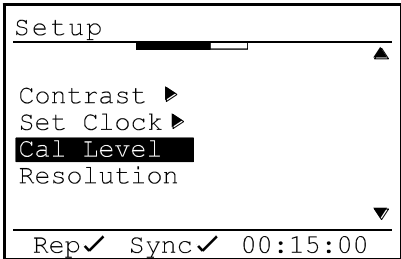
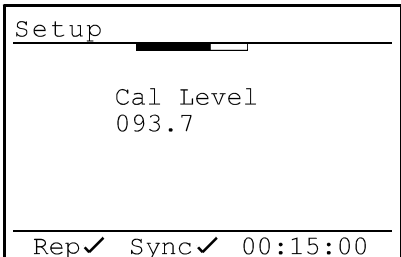
Key Press	Display	Comments
	 <pre> Setup ----- Contrast ▶ Set Clock ▶ Cal Level Resolution ----- Rep✓ Sync✓ 00:15:00           </pre>	
	 <pre> Setup -----           Cal Level           093.7 ----- Rep✓ Sync✓ 00:15:00           </pre>	<p>Use the Up and Down arrows to adjust the level and the Left and Right arrow keys to move between the numbers.</p> <p>Press OK to accept the calibration level.</p>

Cirrus Research plc does not recommend the use of Acoustic Calibrators other than those manufactured or supplied by Cirrus Research plc for use with the CR:800B instruments.

Refer to the operating manual supplied with the Acoustic Calibrator to be used for details of the correction required for use with an MK:224 or MK:216 Microphone Capsule.

## Display Resolution

The display resolution of the CR:800B instruments can be set to be either 0.1dB or 0.01dB. For most applications, the 0.1dB resolution is standard.

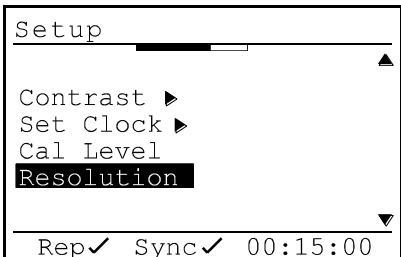
Key Press	Display	Comments
	 <pre> Setup ----- Contrast ▶ Set Clock ▶ Cal Level Resolution ----- Rep✓ Sync✓ 00:15:00           </pre>	

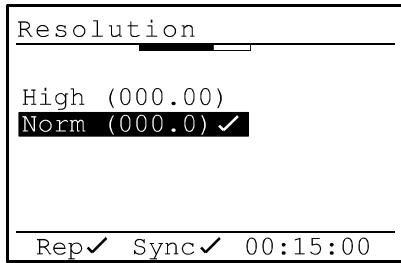

Use the Up and Down arrows keys to select the display resolution and press OK to select the required display resolution.

Press Exit to return to the main display.

### Time Weighting

The Time Weighting of the instrument can be set to either Fast, Slow or Impulse. To set the Time Weighting, select the Time Weighting option from the menu:

Key Press      Display      Comments

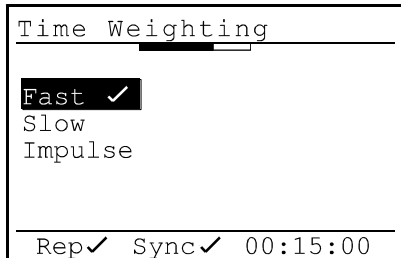
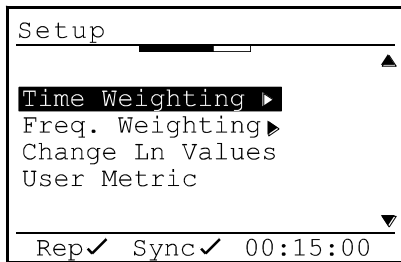

Select the required Time Weighting and press OK to select.

The select Time Weighting is indicated by a tick.

Press Exit to return to the main display.

The Time Weighting applies to the following parameters:

#### Broadband Mode

$L_{AF}, L_{AS}, L_{AI}, L_{CF}, L_{CS}, L_{CI}, L_{ZF}, L_{ZS}$  or  $L_{ZI}$  (not stored)  
 $L_{AFmax}, L_{ASmax}, L_{AImax}, L_{CFmax}, L_{CSmax}, L_{CImax}, L_{ZFmax}, L_{ZSmax}$  or  $L_{ZImax}$   
 $L_{AFmin}, L_{ASmin}, L_{AImin}, L_{CFmin}, L_{CSmin}, L_{CImin}, L_{ZFmin}, L_{ZSmin}$  or  $L_{ZImin}$   
 $L_{0.1}$  to  $L_{99.9}$  (five simultaneous user-selected values available)

The  $L_n$ 's or Statistical parameters are calculated from Sound Level. Therefore, if the Time Weighting is set to Fast, the  $L_n$ 's will be calculated from  $L_{AF}$ , and also for the Slow and Impulse Time Weightings.

#### 1:1 Octave Band Mode

Filtered  $L_{ZS}, L_{ZF}$  or  $L_{ZI}$  (not stored)

#### 1:3 Octave Band Mode

Filtered  $L_{ZS}, L_{ZF}$  or  $L_{ZI}$  (not stored)



## Frequency Weighting

The Frequency Weighting of the instrument can be set to either A, C or Z. To set the Frequency Weighting, select the Frequency Weighting option from the menu:

Key Press      Display      Comments

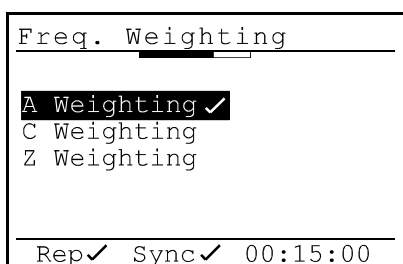
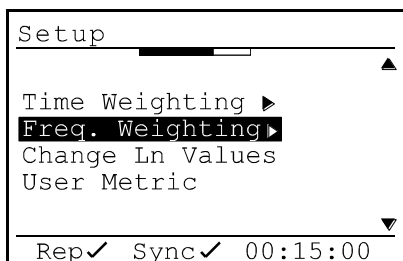

Select the required Frequency Weighting and press OK to select.

The select Frequency Weighting is indicated by a tick.

Press Exit to return to the main display.

The Frequency Weighting applies to the following parameters:

### Broadband Mode

Integrated Sound Level	$L_{Aeq}, L_{Ceq},$ or $L_{Zeq}$
Sound Level	$L_{AF}, L_{AS}, L_{AI}, L_{CF}, L_{CS}, L_{CI}, L_{ZF}, L_{ZS}$ or $L_{ZI}$ (not stored)
Maximum Sound Level	$L_{AFmax}, L_{ASmax}, L_{AImax}, L_{CFmax}, L_{CSmax}, L_{CImax}, L_{ZFmax}, L_{ZSmax}$ or $L_{ZImax}$
Minimum Sound Level	$L_{AFmin}, L_{ASmin}, L_{AImin}, L_{CFmin}, L_{CSmin}, L_{CImin}, L_{ZFmin}, L_{ZSmin}$ or $L_{ZImin}$
User Metric	$L_{AE}, L_{CE},$ or $L_{ZE}, L_{AIEq}, L_{CIEq},$ or $L_{ZIEq}, L_{AFTEq}$

### 1:1 Octave Band Mode

No measurements are affected by the Frequency Weighting. All 1:1 Octave Bands are measured with the Z Frequency Weighting.

### 1:3 Octave Band Mode

No measurements are affected by the Frequency Weighting. All 1:3 Octave Bands are measured with the Z Frequency Weighting.

### Ln values

The five preset Ln or Statistical values that are calculated at the end of a Broadband measurement can be configured to different values.

The default values are  $L_{1.0}, L_{10.0}, L_{50.0}, L_{90.0}$  and  $L_{95.0}$

To change the Ln values, select Change Ln Values from the Setup Menu.

Key Press      Display      Comments

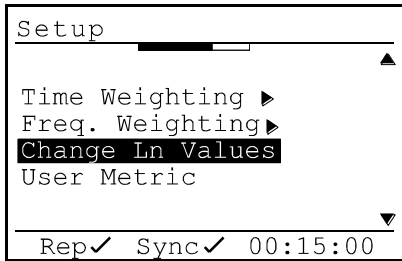

OK

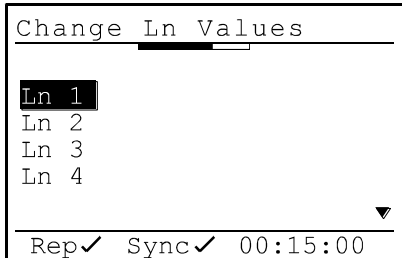

The Ln to be changed can be selected using the Up and Down arrow keys.

Press OK to select the Ln to change.

OK

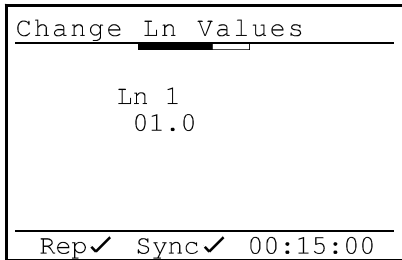

In this example, the Ln1 has been selected.

Use the Up and Down arrow keys to change the value and the Left and Right arrow keys to move between the numbers.

Press OK to accept the changes or Exit to discard any changes.

The other Ln values can be altered in the same manner as shown above.

### User Metric

The additional measurement parameter provided the CR:800B instrument is known as the User Metric.

This measurement parameter can be selected to be either  $L_E$  (Sound Exposure Level, SEL),  $L_{Ieq,t}$  (Impulse Weighted Time Weighted Sound Level) or  $L_{AFTeq}$  (Takt Maximal Sound Level).

Key Press      Display      Comments

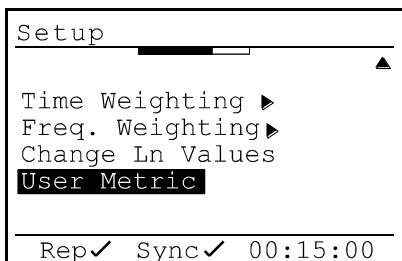



User Metric	
SEL	✓
LAFteq	
LLeqT	
Rep ✓ Sync ✓ 00:15:00	

Select the required User Metric and press OK to select.

The select User Metric is indicated by a tick.

Press Exit to return to the main display.



Note that if the LLeq,t function is selected, the CR:800B will automatically select the Impulse Time Weighting which will apply to all other measurement functions described in section Time Weighting on page 40.

Before the Time Weighting can be selected to either Fast or Slow, the User Metric must be set to SEL.

### Configuring the instrument from the Deaf Defier3 software

The entire configuration of the instrument can be set from the Deaf Defier3 software using the Advanced Configuration option. Please refer to page 80 for details of this function.

## Section 4 Viewing and Downloading the measurements

When a measurement stops, either by the user pressing the Stop key or when a measurement stops automatically, the data is automatically stored in the memory.

### Recalling Stored Measurements

To view stored measurements, ensure that the instrument is not running. Press the right hand arrow key to view the first stored measurement and the left hand arrow key to view the last measurement stored.

Key Press	Display	Comments
		
		The first measurement stored is shown.  The parameters displayed depend upon the measurement type.
		The last measurement stored is shown.  The parameters displayed depend upon the measurement type.

Cirrus CR:800B

97.0 LAF dB

25/06/03 07:25:56



Mem 1      Broadband

Elapsed    00:15:00

LAeqt     53.5 dB

LCpeak    95.0 dB

LAE        82.9 dB

30/06/03 11:12:07

The first measurement stored is shown.

The parameters displayed depend upon the measurement type.



Mem 10     Broadband

Elapsed    00:15:00

LAeqt     53.5 dB

LCpeak    95.0 dB

LAE        82.9 dB

30/06/03 11:12:07

The last measurement stored is shown.

The parameters displayed depend upon the measurement type.

The measurement type is shown at the top of the screen next to the measurement number. The different measurement types have different parameters that are displayed and these are described below

## Broadband Measurement

Key Press

Display

Comments

Mem 10		Broadband	
Elapsed	00:15:00		
LAeqt	53.5 dB		
LCpeak	95.0 dB		
LAE	82.9 dB		
30/06/03		11:12:07	

The User Metric setting of the instrument determines if the unit stores LAE, LAIeq,t or LAFteq.

If the unit was in Overload or Under-Range during the measurement this is indicated on the screen.



Mem 10		Broadband	
LAFmin	36.5 dB		
LAFmax	66.9 dB		
L01.0	60.2 dB		
30/06/03		11:12:07	



Mem 10		Broadband	
L10.0	56.4 dB		
L50.0	50.5 dB		
L95.0	38.3 dB		
L99.0	37.6 dB		
30/06/03		11:12:07	

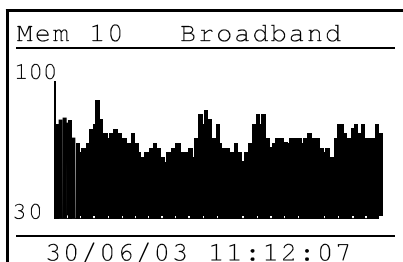

The whole measurement duration is displayed on the screen when the Time History data is reviewed.

## 1:1 Octave Band Measurements

Key Press

Display

Comments

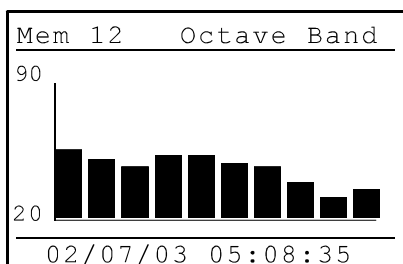

The graphical display of the 1:1 Octave Band measurement is shown with the measurement range shown on the left hand scale.



Mem 12		Octave Band
31.5 Hz	56.6	dB
62.5 Hz	52.3	dB
125 Hz	43.9	dB
250 Hz	54.4	dB
02/07/03 05:08:35		



Mem 12		Octave Band
500 Hz	53.6	dB
1 kHz	49.0	dB
2 kHz	45.4	dB
4 kHz	33.8	dB
02/07/03 05:08:35		



Mem 12		Octave Band
8 kHz	28.5	dB
16 kHz	34.7	dB
02/07/03 05:08:35		



Mem 12		Octave Band
A	60.1	dB
C	54.4	dB
Z	74.1	dB
02/07/03 05:08:35		

### 1:3 Octave Band Measurements

Key Press      Display

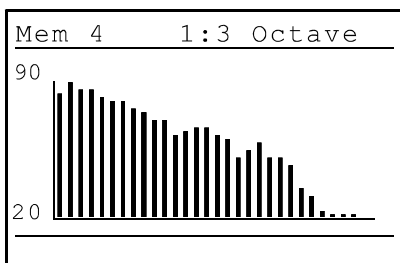

Comments

The graphical display of the 1:3 Octave Band measurement is shown with the measurement range shown on the left hand scale.

Mem 4		1:3 Octave
25 Hz	78.3	dB
31.5 Hz	84.2	dB
40 Hz	79.7	dB
50 Hz	80.4	dB
30/06/03 09:12:45		

Mem 4	1:3 Octave
62.5 Hz	78.3 dB
80 Hz	75.2 dB
100 Hz	74.9 dB
125 Hz	70.8 dB

30/06/03 09:12:45

Mem 4	1:3 Octave
160 Hz	64.6 dB
200 Hz	61.2 dB
250 Hz	60.7 dB
315 Hz	49.7 dB

30/06/03 09:12:45

Mem 4	1:3 Octave
400 Hz	55.3 dB
500 Hz	58.3 dB
630 Hz	58.7 dB
800 Hz	54.7 dB

Mem 4	1:3 Octave
1 kHz	52.0 dB
1.25kHz	44.7 dB
1.6 kHz	46.5 dB
2 kHz	49.6 dB

30/06/03 09:12:45

Mem 4	1:3 Octave
2.5 kHz	49.6 dB
3.15kHz	46.5 dB
4 kHz	42.7 dB
5 kHz	32.3 dB

30/06/03 09:12:45

Mem 4	1:3 Octave
6.25kHz	28.6 dB
8 kHz	30.1 dB
10 kHz	26.3 dB
12.5kHz	20.5 dB

30/06/03 09:12:45

Mem 4	1:3	Octave
16 kHz	19.3	dB
A	65.0	dB
C	85.2	dB
Z	92.2	dB
30/06/03 09:12:45		

### Checking & Clearing the memory

The memory of the instrument can be checked for available space and also to allow the user to delete the measurements that are stored. To check the available memory, select the Memory option from the menu:

Key Press      Display      Comments

	<p>CR:800B Menu</p> <hr/> <p>Run Durations ▶</p> <p><b>Memory ▶</b></p> <p>Setup ▶</p> <p>Print Options</p> <hr/>	
-----------------------------------------------------------------------------------	-------------------------------------------------------------------------------------------------------------------	--

	<p>Memory</p> <hr/> <p><b>Available Memory</b></p> <p>Clear Memory</p> <hr/>	
-------------------------------------------------------------------------------------	------------------------------------------------------------------------------	--

	<p>Memory</p> <hr/> <p>Measurement 99% Free</p> <p>Time History 63% Free</p> <hr/>	
-------------------------------------------------------------------------------------	--------------------------------------------------------------------------------------------	--

To clear all the measurements from the memory, use the Clear Memory option:

Key Press      Display      Comments

	<p>Memory</p> <hr/> <p>Available Memory</p> <p><b>Clear Memory</b></p> <hr/>	
-------------------------------------------------------------------------------------	------------------------------------------------------------------------------	--



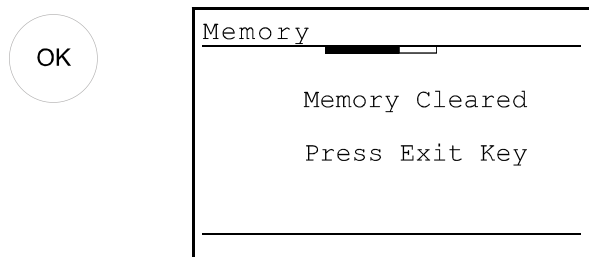
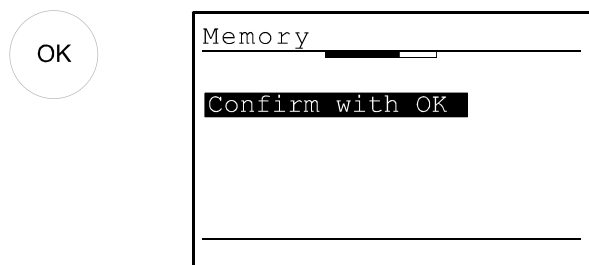

Please note that when the memory has been cleared, any measurement previously stored cannot be retrieved and are permanently deleted.

### Downloading Measurements to the Software

Before measurements can be downloaded, the software must be installed on to a suitable PC.

### Software Installation

The Deaf Defier3 software must be installed before measurements can be downloaded. Please refer to page 79 for details of the installation of the Deaf Defier3 software.

### Connecting the instrument to the PC

The CR:800B instruments connect to the PC using the supplied ZL:800 RS232 Cable. This connection requires a free 9 Pin RS232 Serial port on the PC. If no RS232 port is available, a USB Adaptor (ZL:101) is available as a cost option. Please contact your local representative or Cirrus Research plc for further information.

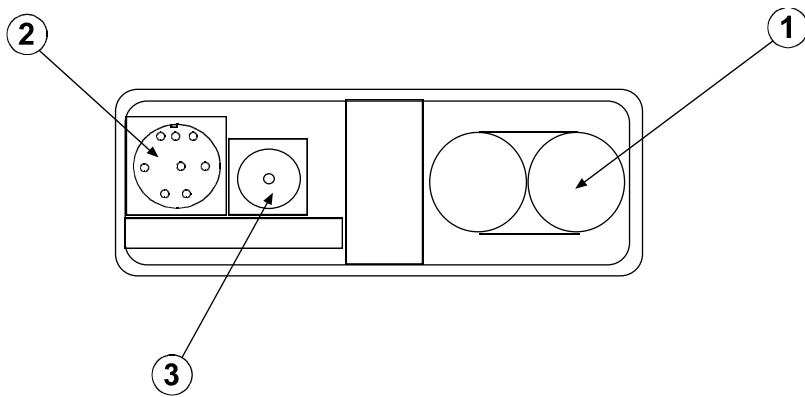

Connect the ZL:800 Cable to the RS232 socket, (2) in the diagram above, on the bottom of the instrument. Ensure that the cable is inserted correctly with the arrow on the top of the connector. Do not force the connector into the socket as this may cause damage.

Connect the 9 Pin DIN socket to a free RS232 socket on the PC.

When the Deaf Defier3 software is installed and run, use the Download option to connect to the instrument. The Deaf Defier3 software will automatically detect the CR:800B instrument and allow measurements to be downloaded.

Please refer to the Help provided with the Deaf Defier3 software for details of the download procedure.

---

## Understanding how the measurements are stored

The memory of the CR:800B can store up to 1,300 measurements. Each measurement is known as an Event and can be either Broadband, 1:1 Octave Band or 1:3 Octave Band.

The duration of each measurement does not affect the size that it takes, but the different measurements types take up different amounts of space in the instrument memory.

For example, a Broadband measurement take 1 memory slot, a 1:1 Octave measurement takes 2 memory slots and a 1:3 Octave measurement takes 3 memory slots.

The diagram below shows how the different measurements take up different amounts of memory space.

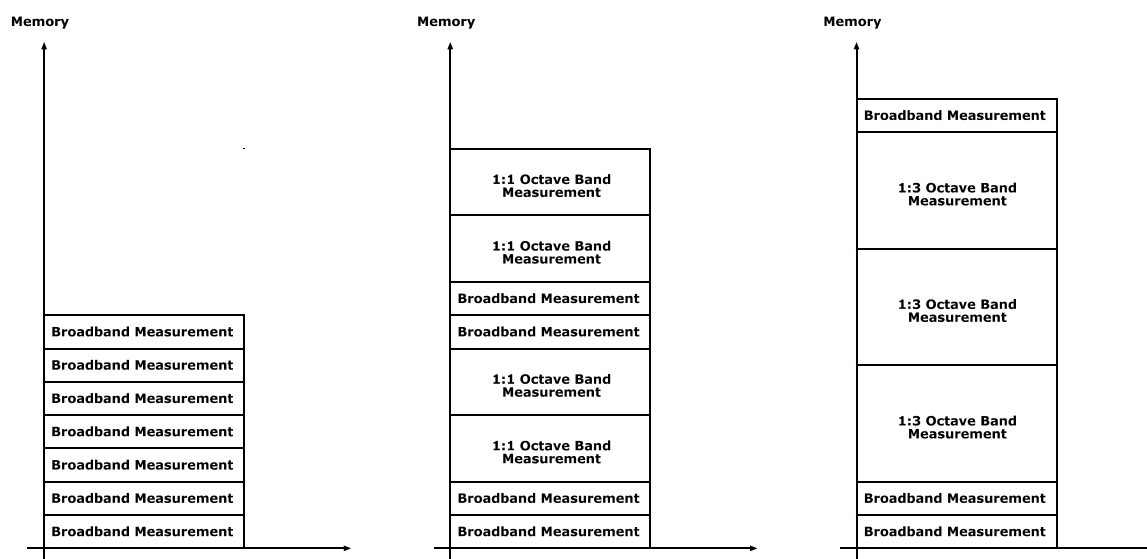

The maximum time over which Broadband measurements can be stored depends upon the duration of the measurement. The table below shows the maximum time over which measurements can be made. Please note that this applies only to Broadband Measurements using the Auto Repeat function.

Measurement Duration	Maximum Length of Measurement
1 minute	21.5 hours
5 minutes	4.5 days
15 minutes	13.5 days
30 minutes	27 days
1 hour	54 days

With each Broadband Measurement is also stored a Time History measurement. This information is stored in a separate memory from the Events and does not take up any of the 1,300 Event memories. However, the Time History memory is limited to a size of 1,008,000 samples at 1 second samples, which is just over 11 days of data storage.

If the Time History Store is full before the Event Memory Store, the Event measurements will continue but will not have Time History data.

The diagram below shows an example of this.

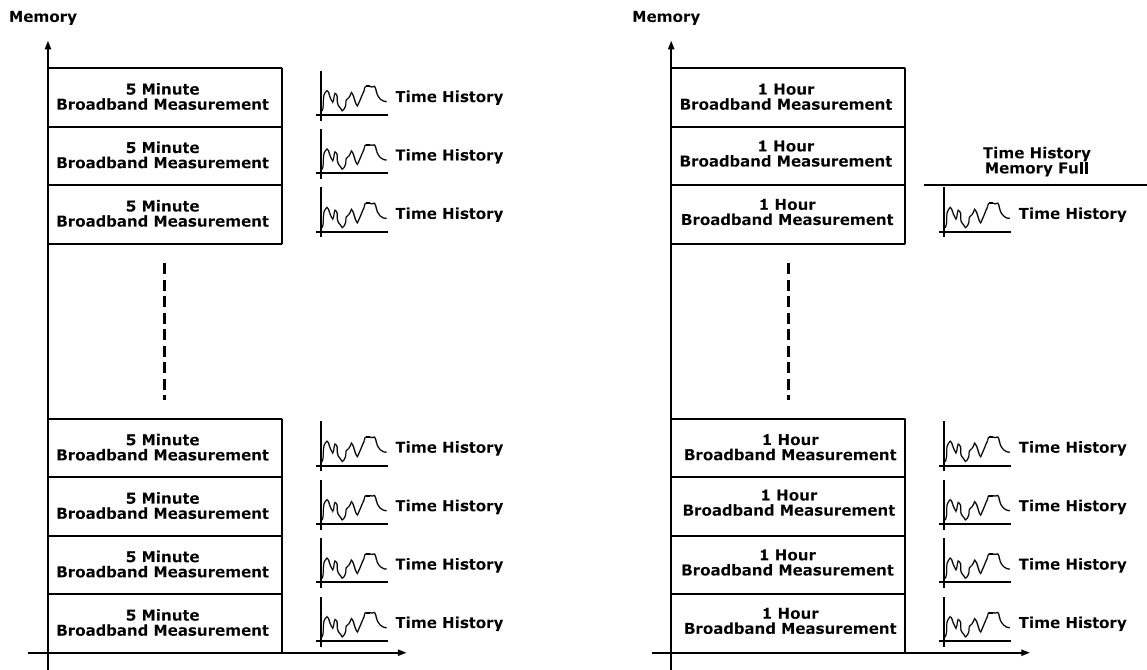

## Section 5 Maintenance & Care

The CR:800B is a precision measurement instrument and should be treated with care. Do not allow the instrument to be exposed to substances which may cause damage to the components of the unit. If the instrument is to be used in an environment where particles such as dust may come into contact with the instrument, always use a Windshield (UA:237) to protect the microphone capsule.

The CR:800B is not waterproof and should not be used in situations where moisture will form or condense on the microphone capsule or the instrument body. If using the CR:800B outdoor, use a suitable outdoor measurement kit which has been specifically designed to protect the instrument.

If the CR:800B becomes dusty, wipe it down with a cloth that is lightly dampened with water or a mild detergent. Do not use aromatic hydrocarbons, chlorinated solvents, or methanol-based fluids when wiping down the meter.

Do Not clean the microphone capsule. Do Not remove the microphone grill as this can cause severe damage to the membrane. Physical damage to the microphone capsule is not covered by the instrument warranty.

If you experience any problems with the operation of the instrument, refer to page 54 for basic troubleshooting. If this does not solve the problem, contact Cirrus Research plc or your local representative for further assistance.

---

## Section 6 Troubleshooting

This section contains information which may solve simple operational problems you may encounter. If you are unable to solve the problem or experience any problems with the assembly or operation of the instrument contact Cirrus Research plc or your local representative for further assistance

### Basics

Symptom	Possible Cause	Possible Remedy
The instrument does not switch on	The batteries are not fitted	Fit new batteries and switch on
	The batteries are flat or very low	Fit new batteries and switch on
	The batteries are not correctly fitted	Remove the batteries and check the polarity of the batteries

### Calibration

Symptom	Possible Cause	Possible Remedy
The calibration fails: Too Low	The Acoustic Calibrator is not switched on	Switch on the Acoustic Calibrator and retry
	The Acoustic Calibrator is not fitted correctly	Check that the Acoustic Calibrator is fitted according to the instructions supplied.
	The Preamplifier is not fitted correctly. Type 1 Instruments only	For Type 1 Instruments, refer to page 14 for details of fitting the preamplifier.
	The microphone capsule is loose or not fitted	Check that the microphone capsule is tight and fitted correctly
	Calibration level set to a different level	Set the calibration level to the value provided by the Acoustic Calibrator. See page 38
	The Microphone may be damaged	Contact Cirrus Research plc or your local representative for assistance
The calibration fails: Too High	The Acoustic Calibrator is set to a higher level than the expected level	Set the Acoustic Calibrator to the correct level
The calibration fails: Unstable	The background noise level is within 15dB of the calibration level	Move to a location where the background noise level is more than 15dB below the calibration level
	The Microphone may be damaged	Contact Cirrus Research plc or your local representative for assistance

### Measurements & Settings

Symptom	Possible Cause	Possible Remedy
No measurements have been	Memory is full.	Check the available memory.

stored		See page 48
	The measurement was reset	Restart the measurement
In 1:1 or 1:3 Octave Band Mode, the filters do not automatically sweep	The Run Duration has been set to Manual.	Select a Preset Run Duration
The measurements are not aligned with the clock	The Auto-Synchronise function is switched off	Switch on the Auto-Synchronise function
Instrument has selected Impulse Time weighting	$L_{\text{reqt}}$ User Metric may have been selected	Select SEL User Metric and change Time Weighting required
Overload symbol is shown	The noise level is too high for the current range	Select a higher measurement range
Under Range symbol is shown	The noise level is too low for the current range	Select a lower measurement range.
The measurement stops after a set time	The Run Duration has been set to a preset value.	Select the Manual Run Duration
	The Run Duration has been set to the User Defined value.	Select the Manual Run Duration
The measurement does not stop as expected	The Run Duration has been set to Manual	Select a preset Run Duration

## Downloading Measurements

Symptom	Possible Cause	Possible Remedy
Measurements cannot be downloaded	No measurements have been stored	Repeat Measurement
	Instrument is not connected to PC	Connect RS232 Cable to the instrument and the PC.
	Batteries are too low	Replace batteries

## Section 7 Glossary

1:1 Octave Band Filters	A division of the frequency range into bands, the upper frequency limit of each band being twice the lower frequency limit.
1:3 Octave Band Filters	Single 1:1 Octave bands divided into three parts.
A Weighting	A standard weighting of the audible frequencies designed to reflect the response of the human ear to noise.
Acoustic Calibrator	An instrument that provides a reference noise source that is used to calibrate and check the performance of a Sound Level Meter.
Broadband	Noise Measurements using parameters which include all the audible noise, such as dB(A) and dB(C)
C Weighting	A standard weighting of the audible frequencies used for the measurement of Peak Sound Pressure level.
CE Marking	A label used to show that the Sound Level Meter conforms to the specification of a European Directive
dB(A)	Decibels A weighted
dB(C)	Decibels C Weighted
dB(Z)	Decibels Z weighted
Decibel (dB)	The units of sound level and noise exposure measurement
DIN 45641	German Standard which defines the additional measurements $L_{AF_{Teq}}$ & $L_{IeqT}$
Fast Time Weighting	A standard time weighting applied by the Sound Level Meter
IEC 60651:1979	The International Standard for Sound Level Meters
IEC 60804:1984	The International Standard for Integrating & Integrating-Averaging Sound Level Meters
IEC 61260:1995	The International Standard for 1:1 Octave & 1:3 Octave Band Filters
IEC 61672-1:2003	The International standard for Sound Level Meter and Integrating Averaging Sound Level Meters that replaces both IEC 60651 and IEC 60804
Impulse Time Weighting	A standard time weighting applied by the Sound Level Meter
Integrating Averaging Sound Level Meter	A Sound Level Meter which accumulates the total sound energy over a measurement period and calculates an average
$L_{A10.0}$	The noise level exceeded for 10% of the measurement period with 'A' frequency weighting calculated by statistical analysis
$L_{A90.0}$	The noise level exceeded for 90% of the measurement period with 'A' frequency weighting calculated by statistical analysis
$L_{AE}$	Sound Exposure Level (SEL) with 'A' frequency weighting
$L_{Aeq,t}$	Equivalent continuous sound pressure level. A measure of the average sound pressure level during a period of time, t, in dB with 'A' weighting.



---

L <sub>AF</sub>	Sound level with 'A' Frequency weighting and Fast Time weighting
L <sub>AFmax</sub>	The maximum Sound level with 'A' Frequency weighting and Fast Time weighting
L <sub>AFmin</sub>	The minimum Sound level with 'A' Frequency weighting and Fast Time weighting
L <sub>AFTeq</sub>	Takt maximal sound level as defined by DIN 45641
L <sub>AI</sub>	Sound level with 'A' Frequency weighting and Impulse Time weighting
L <sub>AImax</sub>	The maximum Sound level with 'A' Frequency weighting and Impulse Time weighting
L <sub>AImin</sub>	The minimum Sound level with 'A' Frequency weighting and Impulse Time weighting
L <sub>AS</sub>	Sound level with 'A' Frequency weighting and Slow Time weighting
L <sub>ASmax</sub>	The maximum Sound level with 'A' Frequency weighting and Slow Time weighting
L <sub>ASmin</sub>	The minimum Sound level with 'A' Frequency weighting and Slow Time weighting
L <sub>CE</sub>	Sound Exposure Level (SEL) with 'C' frequency weighting
L <sub>ceq,t</sub>	Equivalent continuous sound pressure level. A measure of the average sound pressure level during a period of time, t, in dB with 'C' weighting.
L <sub>CF</sub>	Sound level with 'C' Frequency weighting and Fast Time weighting
L <sub>CFmax</sub>	The maximum Sound level with 'C' Frequency weighting and Fast Time weighting
L <sub>CI</sub>	Sound level with 'C' Frequency weighting and Impulse Time weighting
L <sub>CImax</sub>	The maximum Sound level with 'C' Frequency weighting and Impulse Time weighting
L <sub>Cpeak</sub>	Peak Sound pressure level with 'C' frequency weighting
L <sub>CS</sub>	Sound level with 'C' Frequency weighting and Slow Time weighting
L <sub>CSmax</sub>	The maximum Sound level with 'C' Frequency weighting and Slow Time weighting
L <sub>EP,d</sub>	Daily personal noise exposure
L <sub>eq</sub>	Equivalent continuous sound pressure level. A measure of the average sound pressure level during a period of time, t, in dB
L <sub>IeqT</sub>	Impulse weighted L <sub>eq,t</sub> as defined by DIN 45641
L <sub>n</sub>	Statistical analysis of noise levels. The n denotes the percentage exceedence.
L <sub>ZE</sub>	Sound Exposure Level (SEL) with 'Z' frequency weighting
L <sub>Zeq,t</sub>	Equivalent continuous sound pressure level. A measure of the average sound pressure level during a period of time, t, in dB with 'Z' weighting.
L <sub>ZF</sub>	Sound level with 'Z' Frequency weighting and Fast Time weighting
L <sub>ZFmax</sub>	The maximum Sound level with 'Z' Frequency weighting and Fast Time weighting

---

L <sub>ZI</sub>	Sound level with 'Z' Frequency weighting and Impulse Time weighting
L <sub>ZImax</sub>	The maximum Sound level with 'Z' Frequency weighting and Impulse Time weighting
L <sub>ZS</sub>	Sound level with 'Z' Frequency weighting and Slow Time weighting
L <sub>ZSmax</sub>	The maximum Sound level with 'Z' Frequency weighting and Slow Time weighting
Overload	The input to the Sound Level Meter is too high for the current measurement range. Change the range
Peak	The maximum value reached by the sound pressure at any instant during a measurement period (in dB usually with C frequency weighting)
SEL	Sound Exposure Level, displayed as L <sub>AE</sub> , L <sub>CE</sub> or L <sub>ZE</sub>
Slow Time Weighting	A standard time weighting applied by the Sound Level Meter
Sound Level	Sound Pressure Level with a Frequency weighting, such as dB(A)
Sound Level Meter	An instrument for measuring various noise parameters
SPL	Sound Pressure Level, the basic measure of noise loudness, expressed in decibels
Statistical Analysis	A calculation performed by a Sound Level Meter on the noise levels measured during the measurement period to describe the statistical spread of the noise.
Time History	A sample of the noise levels taken every 1 second throughout the measurement period.
Type 1	Laboratory & Field Grade for Sound Level Meters
Type 2	General Field Grade for Sound Level Meter
Under Range	The input to the Sound Level Meter is too low for the current measurement range. Change the range
Z Weighting	Z weighting is a flat frequency response of 8Hz – 20kHz ±1,5dB excluding microphone response.

---

## Appendix 1 Menu Structure

The structure of the menu system of the CR:800B Sound Level Meter is shown below for reference.

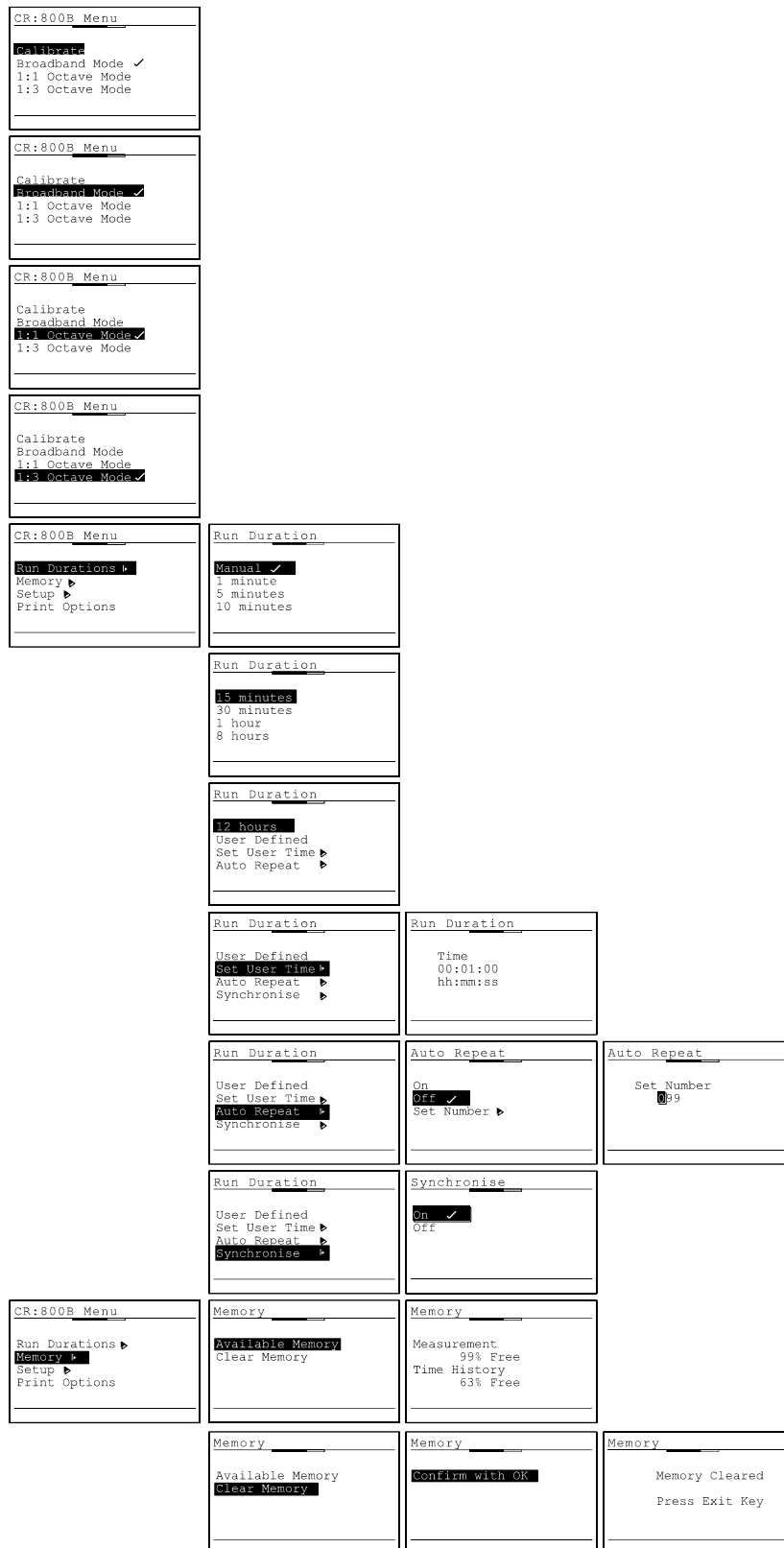

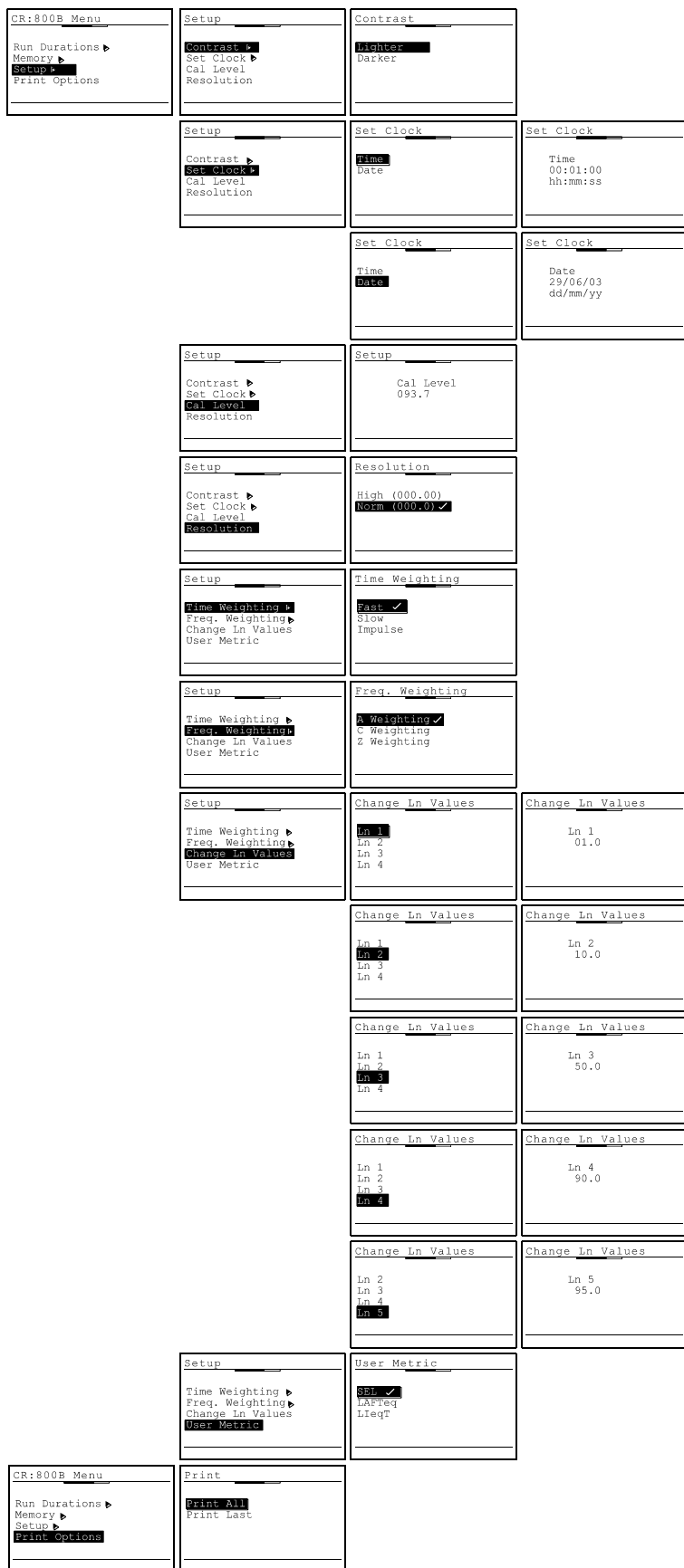

## Appendix 2 Rating Plate Information

The CR:800B meets IEC60651:1979 and IEC60804 1985. These specifications require that this manual provides detailed information to verify that the specifications are met. While much of the data required is in the body of this manual, the points required to be detailed are listed below in the order in which they occur in the IEC specification. The numbers marked after to IEC number refer to that documents paragraph numbers for reference.

### Additional information

The following data assumes the fitting of a MK:224 Type 1 microphone capsule unless otherwise stated. For type 2 units an MK:216 is generally fitted. Although a Type 2 CR:800B has an identical electronic design and should meet the electrical performance tests to Type 1 this is not guaranteed and it should be assumed that Type 2 tolerances apply as specified in the relevant standards to electrical as well as acoustic performance.

#### IEC804/651 11.2.1

The MK:224 Type 1 Electret microphone is used for the CR:811B, CR:821B and CR:831B, mounted on the plug- in pre-amplifier MV:200C. An extension cable or gooseneck is not required to meet fully the standards claimed.

The MK:216 Type 2 Electret microphone is used for the CR:812B, CR:822B and CR:832B, mounted on the integral pre-amplifier MV:200C. An extension cable or gooseneck is not required to meet fully the standards claimed.

#### IEC804/651 11.2.2

The reference direction of incidence is parallel to the sides of the case towards the microphone capsule..

#### IEC804/651 11.2.3

The range of measurement for  $L_{eq}$  and SPL measurement with a standard assembly is:-  
 : 25 to 140 dBA  
 : 37 to 140 dBC  
 : 45 to 140 dBZ

For signals with a crest factor of up to 10 the top span of the unit can be reduced by up to 17dB. This means that a signal with a crest factor of ten will produce an overload at 17dB below the expected top of the range selected. The reading of this signal will be within the tolerances of IEC60651 up to the point where the overload occurs.

The following table details the expected linearity for each range and frequency weighting for various pure sine wave frequencies.

CR:800B Linearity Table for $L_{eq}$ and $L_A$ measurements (Results in brackets are typical values - Noise floor typically 7dB below lower value )					
NOMINAL RANGE	A-weighting 1kHz	A-weighting 31Hz	A-weighting 8kHz	C-weighting 1kHz	Z-weighting 1kHz
70-140dB	68-140dBA (65-141dBA)	68-100dBA (65-103dBA)	68-139dBA (65-140dBA)	68-140dBC (65-141dBC)	68-140dBZ (65-141dBZ)
60-130dB	58-130dBA (55-131dBA)	58-90dBA (55-91dBA)	58-129dBA (55-130dBA)	58-130dBC (55-131dBC)	58-130dBZ (56-131dBZ)
50-120dB	48-120dBA (45-121dBA)	48-90dBA (45-91dBA)	48-120dBA (45-121dBA)	48-120dBC (45-121dBC)	48-120dBZ (46-121dBZ)
40-110dB ref range	38-110dBA (35-111dBA)	38-90dBA (35-91dBA)	38-110dBA (35-111dBA)	38-110dBC (36-111dBC)	40-110dBZ (39-111dBZ)

30-100dB	28-100dBA (26-101dBA)	28-80dBA (25-81dBA)	28-100dBA (25-101dBA)	30-100dBC (28-101dBC)	36-100dBC (34-101dBC)
20-90dB	18-90dBA (15-91dBA)	18-70dBA (15-71dBA)	18-90dBA (14-91dBA)	24-90dBC (22-91dBC)	36-90dBZ (34-91dBZ)
10-80dB	18-80dBA (15-81dBA)	18-65dBA (15-67dBA)	18-80dBA (16-81dBA)	18-80dBC (21-81dBC)	36-90dBZ (35-91dBZ)

The range of measurement for Peak measurement is:-  
: 60 to 143 dB(C)

The peak values are valid for 3dB above and 40dB below the top of each range unless an overload occurs.

#### IEC804 11.2.4

Linearity (and pulse range)

There are seven ranges available spaced by 10dB steps from the lowest range (10-80dB) to the highest (70-140dB).

With 'A' Frequency Weighting, for each range the linearity range exceeds 70dB and the pulse exceeds 73dB except for the lowest range where the linearity and pulse range are reduced by 5dB due to the higher noise floor.

#### IEC804 11.2.7 IEC651 11.2.4

The reference sound pressure is 1 Pa (94dB).

#### IEC804 11.2.5

The integration periods can be set to any period from 10sec to 99hours or use the preset values of 5min,10min,15min,30min,1hr,8hrs and12hrs

#### IEC651 11.2.5

The nominal frequency weighting characteristic for measurements apart from Peak is A weighting. Peak has a fixed C weighting. A C or Z weighting for the other channel can be selected although this selection will also apply to the Leq measurements at the same time.

Z weighting has an electrical design centre of 8Hz to 20kHz +0.2dB/-0.5dB on all ranges.

#### IEC651 11.2.6

"F", "S" and "I" responses are fitted with a 'Maximum Hold' on the max RMS value of each. This parameter can be read when the unit is in a 'run mode'. Peak is fitted on an independent C weighted channel.

#### IEC804 11.2.9 IEC651 11.2.7

An acceleration of 0.1g over the frequency range 63 - 4kHz results in a reading of less than 50dB on any axis or weighting.

#### IEC804 11.2.10 IEC651 11.2.8

1 oersted produces a reading of less than 50dB on any weighting.

#### IEC804 11.2.11 IEC651 11.2.9

The units operate from - 10 degree C to + 50 degree C with a maximum reading change of +0.5dB but is typically less than 0.3dB..

#### IEC651 11.2.10

We recommend that the operator should be at least 1m from the microphone during measurement.

## IEC804 11.2.12 IEC651 11.2.11

The unit will meet its specification at any humidity from 0 to 95 % RH.

## IEC804 11.2.13 IEC651 11.2.12

Maximum storage temperature of +60 degree (+50 degree extended period) and 50% RH should be observed. Care should be taken when taking an instrument rapidly from sub zero temperatures to room temperature or above as condensation can take place inside the instrument and temporarily affect accuracy. No long-term damage should take place however.

## IEC804 11.2.14 IEC651 11.2.13

Use of a ZL:202 (2m) ZL:205 (5m) or ZL:210 (10m) extension cable will not affect the calibration.

## IEC804 11.2.15 IEC651 11.2.14

The UA:237 windscreen has a small effect on frequency response as follows:

Up to 1kHz	no effect
1259Hz	+0.1dB
1585Hz	+0.2dB
1995Hz	+0.3dB
2512Hz	+0.3dB
3162Hz	+0.3dB
3981Hz	+0dB
5012Hz	-0.1dB
6310Hz	-0.1dB
7943Hz	+0dB
10000Hz	-0.2dB
12590Hz	-0.7dB

## IEC804 11.2.16 IEC651 11.2.15

The use of a pistonphone (PF:101C) is recommended to ensure long term compliance but for general short term compliance the CR:511F is used. They should be returned to the factory annually to be checked against a secondary or transfer standard. Any corrections specified in the calibrator or pistonphone manual should be applied for temperature or barometric pressure variation.

## IEC804 11.2.17 IEC651 11.2.16

The observer should be behind the case for optimum results. The operator should never be at the side or in front of the unit.

## IEC804 11.2.18 IEC651 11.2.17

Apart from the microphone and pre-amplifier no other device needs to be attached to make complete measurements.

## IEC804 11.2.19 IEC651 11.2.18

The limitations on the electrical impedance that may be connected to the optional outputs:- Any real, positive impedance of zero ohm upwards. Optimum load impedances are specified in this manual. No guarantee on performance can be made if non-Cirrus supplied cables are used.

## IEC804 11.2.6 IEC651 11.2.19

The reference frequency used for calibration is 1kHz.

## IEC804 11.2.8 IEC651 11.2.20

The reference range for IEC 651 purposes is centre range from 40dB to 110dB.

## IEC804 11.2.20 IEC651 11.2.21

The warm up period is less than 10 secs although it is recommended that the unit should be switched on for at least one minute before calibration to provide optimum accuracy. Never

attempt calibration of an instrument that has not stabilised in temperature with its surroundings if you are seeking accurate results.

#### IEC804 11.2.21

The settling time before valid Leq readings of constant signals are within 0.5dB of their final reading is 10secs and within 0.1dB within 1minute.

#### IEC804 11.2.22

The battery life is greater than 20 hours with continuous use for average readings at 20dB below top of scale and at reference conditions. This value will vary dependant on the quality of the Alkaline batteries used and will diminish if levels near top of scale are constantly monitored or if the batteries are at a low temperature.

This battery life will also drop if Octave or Third Octave filters are selected.

#### IEC651 11.2.22

Not applicable.

#### IEC804/651 11.2.23

See microphone data.

#### IEC804/651 11.2.24

Consult Cirrus Research plc

#### IEC804/651 11.2.25

Dummy microphone impedance is 18 pF in series with 50ohm.

#### IEC651 11.2.26

Primary indicator range is 55dB to 95dB on the centre reference range.

#### IEC651 11.2.27

Manual only.

#### IEC651 11.2.28

Test information detailed later in this manual

#### IEC804 11.2.26

An overload will always occur before non-linear distortion takes place.

#### IEC804 11.2.27

The instrument can be factory set for random incidence as an option.

#### IEC804 11.2.28

The indicator range extends beyond the linearity range.

## **Additional filter information**

The CR:800B meets or exceeds IEC 61260 Types 1. The specification IEC 61260 requires that this manual provides detailed information to verify that the specifications are met.

While much of the data required is in the body of this manual, the points required to be detailed are listed below in the order in which they occur in the IEC specification. The numbers marked after the IEC number refer to that documents paragraph numbers for reference.

#### IEC1260 7a

The octave and third octave filters comply with all performance requirements of IEC61260 :1995 Class 1.

---



## IEC1260 7b

The filters are designed using switched capacitor filters preceded by passive anti-aliasing filters and followed by passive clock noise filters.

## IEC1260 7c

The filter centre frequencies are changed by application of a clock frequency that is one hundred times the selected centre band frequency.

## IEC1260 7d

The nominal midband frequencies for the octave filters are known as 31.5Hz, 63Hz, 125Hz, 250Hz, 500Hz, 1000Hz, 2000Hz, 4000Hz, 8000Hz, 16000Hz.

The nominal midband frequencies for the third octave filters are known as 25Hz, 31.5Hz, 40Hz, 50Hz, 63Hz, 80Hz, 100Hz, 125Hz, 160Hz, 200Hz, 250Hz, 315Hz, 400Hz, 500Hz, 630Hz, 800Hz, 1000Hz, 1250Hz, 1600Hz, 2000Hz, 3150Hz, 4000Hz, 5000Hz, 6300Hz, 8000Hz, 10000Hz, 12500Hz & 16000Hz.

## IEC1260 7e

The filters are derived from the 'Base-two' formula. Exact centre frequencies are 24,803Hz, 31,250Hz, 39,373Hz, 49,606Hz, 62,500Hz, 78,745Hz, 99,213Hz, 125.00Hz, 157,49Hz, 198,43Hz, 250.00Hz, 314,98Hz, 396,85Hz, 500.00Hz, 629,96Hz, 793,70Hz, 1000.0Hz, 1259,9Hz, 1587,4Hz, 2000,0Hz, 2519,9Hz, 3174,8Hz, 4000.0Hz, 5039,7Hz, 6349,6Hz, 8000.0Hz, 10079Hz, 12699Hz & 16000Hz.

## IEC1260 7f

The reference level range is the centre range (40dB to 110dB).

## IEC1260 7g

To facilitate testing the instrument is optimised at a level of 109dB on the reference level range ie one dB below top of range and generally about 2dB below overload.

## IEC1260 7h

The reference attenuation is 0dB

## IEC1260 7i

The linear operating range for the CR:800B is 55dB to 95dB.

## IEC1260 7j

The range should be selected such that neither the underrange or overload flags occur during measurement. The following table gives typical noise floor figures for the lowest range selection. For the other ranges noise floors will be at least 10dB below bottom of range.

Typical filter noise figure Leq/LA (+2dB /-5dB)		
freq	1/3 10-80dB RANGE	1/1 10- 80dB RANGE
25Hz	16dB	
31Hz	15dB	19dB
40Hz	14dB	
50Hz	13dB	
63Hz	12dB	17dB
80Hz	11dB	
100Hz	10dB	
125Hz	10dB	13dB
160Hz	9dB	
200Hz	9dB	
250Hz	8dB	11dB
315Hz	8dB	

400Hz	8dB	
500Hz	8dB	10dB
630Hz	8dB	
800Hz	8dB	
1000Hz	8dB	10dB
1250Hz	8dB	
1600Hz	8dB	
2000Hz	8dB	11dB
2500Hz	8dB	
3150Hz	8dB	
4000Hz	9dB	12dB
5000Hz	9dB	
6250Hz	9dB	
8000Hz	10dB	14dB
10000Hz	11dB	
12500Hz	12dB	
16000Hz	13dB	17dB

IEC1260 7k  
Not applicable

IEC1260 7l  
The design flat Z frequency response excluding microphone capsule tolerances is 8Hz-20kHz  
+0.3/-0.5dB.

IEC1260 7m  
The filter is not directly accessible.

IEC1260 7n  
Not applicable

IEC1260 7o  
The instrument will operate from -10°C to +50°C. The instrument may incur damage if  
exposed to temperatures below -20°C or above 60°C.

IEC1260 7p  
The unit meets the requirements set out in IEC651

IEC1260 7q  
The unit meets the requirements set out in IEC651

IEC1260 7r  
The unit meets the requirements set out in IEC651

IEC1260 7s  
The CR:800B will indicate when a low battery condition is approaching or has been exceeded.

IEC1260 7t  
The filter is integral to the CR:800B

IEC1260 7u  
The instrument is fully functional 10 seconds after switch on but a one minute wait is preferable  
for best accuracy.

IEC1260 7v  
Consult Cirrus Research plc

## Appendix 3 Specifications

### Instrument Versions

CR:811B	Type 1
CR:812B	Type 2
CR:821B	Type 1 with 1:1 Octave Band Filters
CR:822B	Type 2 with 1:1 Octave Band Filters
CR:831B	Type 1 with 1:1 & 1:3 Octave Band Filters
CR:832B	Type 2 with 1:1 & 1:3 Octave Band Filters

### Applicable Standards

#### Sound Level Meter

	IEC 60651:1979 Type 1 I or Type 2 I
	IEC 60804:1985 Type 1 or Type 2
	IEC 61672-1:2003 Class 1 or 2 Group X
	ANSI S1.4 with NK:70 Random Incidence Adaptor Fitted
1:1 & 1:3 Octave Band Filters (where fitted)	IEC 61260 Class 1

#### Microphone

Type 1	MK:224 pre-polarized Free-field ½" Condenser
Type 2	MK:216 pre-polarized Free-field ½" Condenser
	Random Incidence to ANSI S1.4 with NK:70 Adaptor
Capacitance	18pF

#### Microphone Preamplifier

Type 1	MV:200C Removable Preamplifier
Type 2	MV:200C Integral Preamplifier

#### Extension cables

ZL:202	2m
ZL:205	5m
ZL:210	10m
ZL:215	15m
ZL:220	20m
ZL:225	25m

#### Time Weightings

'F' (Fast)	to IEC 61672-1:2003 Class 1 or 2 Group X
'S' (Slow)	to IEC 61672-1:2003 Class 1 or 2 Group X
'I' (Impulse)	to IEC 61672-1:2003 Class 1 or 2 Group X

#### Frequency Weightings

Channel 1	'A', 'C' or 'Z'
Channel 2	'C' for Peak

Z weighting is a flat frequency response of 8Hz – 20kHz  $\pm 1.5$ dB excluding microphone response. When either 1:1 or 1:3 Octave Band filters are selected the 'Z' weighting is used.

#### Amplitude Weighting

Q=3 (True Energy Integration)

## Measurement Range

**Broadband** 21dB(A) to 140dB(A) Class/Type 1  
 25dB(A) to 140dB(A) Class/Type 2  
 143dB(C) Peak (70 to 140dB Range)

### 1:1 Octave Band Filters

19dB(Z) to 140dB(Z)

### 1:3 Octave Band Filters

14dB(Z) to 140dB(Z)

## Range Steps

10-80, 20-90, 30-100, 40-110, 50-120, 60-130, 70-140

## Noise Floor (Typical)

## Noise Floor (Typical)

	Self-generated noise				
	L <sub>AF</sub>	L <sub>CF</sub>	L <sub>ZF</sub>	L <sub>Aeq</sub>	L <sub>AE</sub> (t <sub>int</sub> =10s)
Electrical	15dB	22dB	32dB	15dB	25dB
Acoustic (Class/Type 1 Instruments)	18dB	25dB	35dB	18dB	28dB
Acoustic (Class/Type 2 Instruments)	23dB	30dB	40dB	23dB	31dB

### 1:1 Octave Band Filters

12dB(Z) @ 1kHz 1:1 Octave Band

### 1:3 Octave Band Filters

7dB(Z) @ 1kHz 1:3 Octave Band

## Available Measurements

The following metrics can be displayed for a recorded session and stored:

### Broadband Mode

L<sub>CPeak</sub>

L<sub>AF</sub>, L<sub>AS</sub>, L<sub>AI</sub>, L<sub>CF</sub>, L<sub>CS</sub>, L<sub>CI</sub>, L<sub>ZF</sub>, L<sub>ZS</sub> or L<sub>ZI</sub> (not stored)

L<sub>AFmax</sub>, L<sub>ASmax</sub>, L<sub>AImax</sub>, L<sub>CFmax</sub>, L<sub>CSmax</sub>, L<sub>CImax</sub>, L<sub>ZFmax</sub>, L<sub>ZSmax</sub> or L<sub>ZImax</sub>

L<sub>AFmin</sub>, L<sub>ASmin</sub>, L<sub>AImin</sub>, L<sub>CFmin</sub>, L<sub>CSmin</sub>, L<sub>CImin</sub>, L<sub>ZFmin</sub>, L<sub>ZSmin</sub> or L<sub>ZImin</sub>

L<sub>Aeq</sub>, L<sub>Ceq</sub>, or L<sub>Ze</sub>

L<sub>AE</sub>, L<sub>CE</sub>, or L<sub>ZE</sub>, L<sub>AIeq</sub>, L<sub>CIeq</sub>, or L<sub>ZIeq</sub>, L<sub>AFTeq</sub>

L<sub>0.1</sub> to L<sub>99.9</sub> (five simultaneous user-selected values available)

Run time

Date and time

1 second Short L<sub>eq</sub> Noise Profile

The Ln data is calculated from the Sound Level data and is Time Weighted according to the selected Time Weighting.

**Filter mode**

1:1 or 1:3 filter selected  
Selected frequency  
Filtered  $L_{ZS}$ ,  $L_{ZF}$  or  $L_{ZI}$  (not stored)  
Filtered  $L_{Zeq}$  (stored)  
 $L_{Aeq}$ ,  $L_{Ceq}$ ,  $L_{Zeq}$  (stored)  
Run time  
Date and time

**Frequency Bands (Nominal Frequencies)****1:1 Octave Band**

31Hz, 63Hz, 125Hz, 250Hz, 500Hz, 1kHz, 2kHz, 4kHz, 8kHz, 16kHz

**1:3 Octave Band**

25Hz, 31Hz, 40Hz, 50Hz, 63Hz, 80Hz, 100Hz, 125Hz, 160Hz, 200Hz, 250Hz,  
315Hz, 400Hz, 500Hz, 630Hz, 800Hz, 1kHz, 1.25kHz, 1.6kHz, 2kHz, 3,15kHz,  
4kHz, 5kHz, 6.3kHz, 8kHz, 10kHz, 12.5kHz, 16kHz

20Hz & 20kHz with MO:800/6 Factory Option

**Memory**

16Mbit memory allowing up to:  
1300 broadband measurements  
770 1:1 octave measurements  
330 1:3 octave measurements

For example, broadband mode allows 12 days of 15 minute measurements to be stored.

Calibration records are automatically stored in the instrument memory.

**Noise Profile**

Short Leq ( $L_{Aeq}$ ,  $L_{Ceq}$ , or  $L_{Zeq}$ ).  
Up to 11 days at 1 second acquisition

**Automatic Measurements**

The unit can be set to record and store data over fixed times of

1 minute	5 minutes
10 minutes	15 minutes
30 minutes	1 hour
8 hours	12 hours

or a user defined period

Automatic Repeat From 2 to 999 measurements (broadband mode only)

Auto-synchronise to the clock.

**Display**

Matrix LCD with backlight & Quasi Analogue Bar Graph  
Selected measurement parameter with level  
Warnings for Overload, Under Range and  
Low Battery

**Time & Frequency Weighting**

Elapsed measurement time

Real time short Leq (broadband mode)

Graphical 1:1 and 1:3 Octave Band (recall mode only)

Recalled stored measurements

Measurement Range

**Weight**

450 gms

**Dimensions**

Type 1 340mm x 75mm x 25mm

Type 2 300mm x 75mm x 25mm

**Batteries**

2 x 1.5v Alkaline LR6/AA

**Battery Life**

Broadband Typically &gt;30 hours

Filter Mode Typically &gt;20 hours

Battery voltage is continuously monitored and warning is given on display of impending low battery condition. When batteries approach end of life the unit will store any data required and switch off automatically.

**Environmental****Temperature**

Operating -10°C to +50°C

Storage -20°C to +60°C

**Humidity**

Up to 95% RH Non Condensing

**External Connections****RS232 Communications**

Via 8 pin mini Din socket with supplied ZL:800 Cable

Baud Rate: 38,400 Data Bits: 8

Stop Bit: 1 Parity: None

1. TX
2. DC Out
3. Auxillary
4. AC Out
5. Program
6. Digital GND
7. RX
8. Battery Voltage
0. Analogue GND

**Outputs**

Outputs via 8 pin mini Din socket using optional cables

**AC output**

---

**Un-weighted AC Output.**

The Un-weighted AC Output is affected by the range of the Sound Level Meter. The Output is referenced relative to the output on the reference measurement range of 50-110dB. The attenuation of the output is as follows:

Measurement Range	Attenuation
70-140 dB	-10 dB
60-130 dB	0 dB
50-120 dB	0 dB
40-110 dB	0 dB Reference Range
30-100 dB	+10 dB
20-90 dB	+20 dB
10-80 dB	+25dB

**DC output**

DC log signal of the above with time constant as selected.

DC Output = (Level - [Top of Range value] +33dB) /41  
giving approximately 24.4mV/dB

DC Output is affected by:

Measurement Range

Time Weighting

Frequency Weighting

Output Impedance	DC Output	AC Output
	10K	10K in series with 33 $\mu$ F
Optimum Load	>1M <1nF	>1M <470pF

AC & DC Outputs should be loaded by an impedance exceeding 10k (1M Recommended)

**Output Cables**

RS232	ZL:800 RS232 Cable to 9pin Female DIN ZL:803 Serial Printer Cable to 9 pin Male DIN
AC Output	ZL:802 2m to 3.5mm Stereo Jack ZL:804 2m to Male BNC
DC Output	ZL:805 2m to Male BNC Converter Cable 0-1v DC Output

**External Power**

12v – 16.5v DC @ 100mA

CU:195A Mains Power Supply (Optional)

Specify UK, US or EU Type Plug

**Software Support**

Deaf Defier3 for Windows

**System Requirements**

The Deaf Defier3 for Windows requires the following:

Microsoft Windows 95 or later

6Mb of available hard-disk space for program files

CD-ROM Drive  
VGA or higher resolution monitor, Super VGA Recommended  
Microsoft compatible mouse or pointing device  
9 Pin RS232 (Serial) Port  
PC specification  
Minimum: PII 266 MHz  
Recommended: PIII 500 MHz

For Computers without a free RS232 (Serial) Port, a USB-Serial or PC Card-Serial Adaptor may be used to allow communication with the instrument.

### **Factory Options**

MO:800/1	Upgrade from Type 2 to Type 1
MO:800/2	Upgrade from Broadband to 1:1 Octave Band Filters
MO:800/3	Upgrade from Broadband to 1:1 & 1:3 Octave Band Filters
MO:800/4	Upgrade from 1:1 to 1:1 & 1:3 Octave Band Filters
MO:800/5	Remote Preamplifier for Type 2 Instruments
MO:800/6	20Hz & 20kHz 1:3 Octave Band Filters

### **Electromagnetic Performance**

EN 55022:1994	
EN 61000-4-2:1995	
EN 61000-4-3:1996	80MHz - 1GHz
EN 61000-4-3:1996	25MHz - 80MHz
EN 50204:1995	900MHz
EN 61000-4-8:1994	50Hz

---



## Appendix 4 Acoustic Calibrators

### Operation.

#### Switching on the Calibrator

Press the Power Button on the end of the Calibrator to switch the unit on. The Indicator will illuminate to show that the unit is operating.

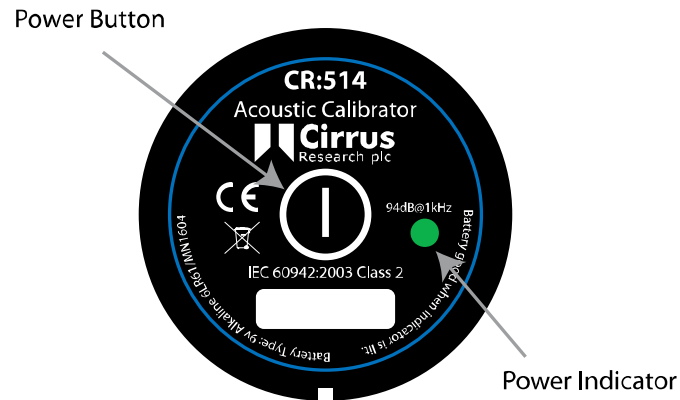

The calibrator will automatically switch off after 5 minutes to preserve battery power.

To switch off the calibrator manually, press the power button again and the indicator will extinguish to show that the unit is switched off.

#### Permanent-on Mode

For some applications there may be a need to have the calibrator switched on continuously. To allow for this, the calibrator can be turned on by pressing and holding the power button for three seconds.

Release the button and the indicator will flash to show that the unit is in permanent-on mode. Press the power button to switch off the calibrator.

### **Calibrating a Sound Level Meter.**

Push the microphone of the Sound Level Meter into the cavity at the end of the calibrator. Ensure the microphone is fully inserted into the cavity and is past the 'O' ring seals. The microphone should be parallel to the body of the calibrator. Also ensure that the small bleed-hole next to the microphone cavity is not blocked as this could cause damage to the microphone.

Most modern Sound Level Meters have electronic calibration with the level adjusted automatically. Adjust the Sound Level Meter to the correct level where applicable. When correcting the value generated by the calibrator a correction for the type of microphone capsule may need to be applied (see Appendix 2)

### **Background Noise**

In order for the calibrator to operate as intended, the ambient acoustic noise level should be no greater than 80dBA.

### **Stabilisation**

In order for the sound pressure level and frequency to stabilise after switching the calibrator on when coupled to a microphone, a period of at least 3 seconds should be allowed before performing a calibration.

---

## Changing the Battery

The CR:514 & CR:515 acoustic calibrators use a single 9v alkaline battery. This type of battery is known as 6F22 or NEDA 1604. It is also commonly known as PP3.

1. Unscrew the screw holding the battery cover on, using a coin.
2. The battery, type 6F22 (PP3) can now be eased out of its holder and replaced. The battery should be eased out terminal side first by pushing against the spring at the other end. Ensure that the battery is inserted with the correct polarity with the negative terminal at the contact with the larger cutout.

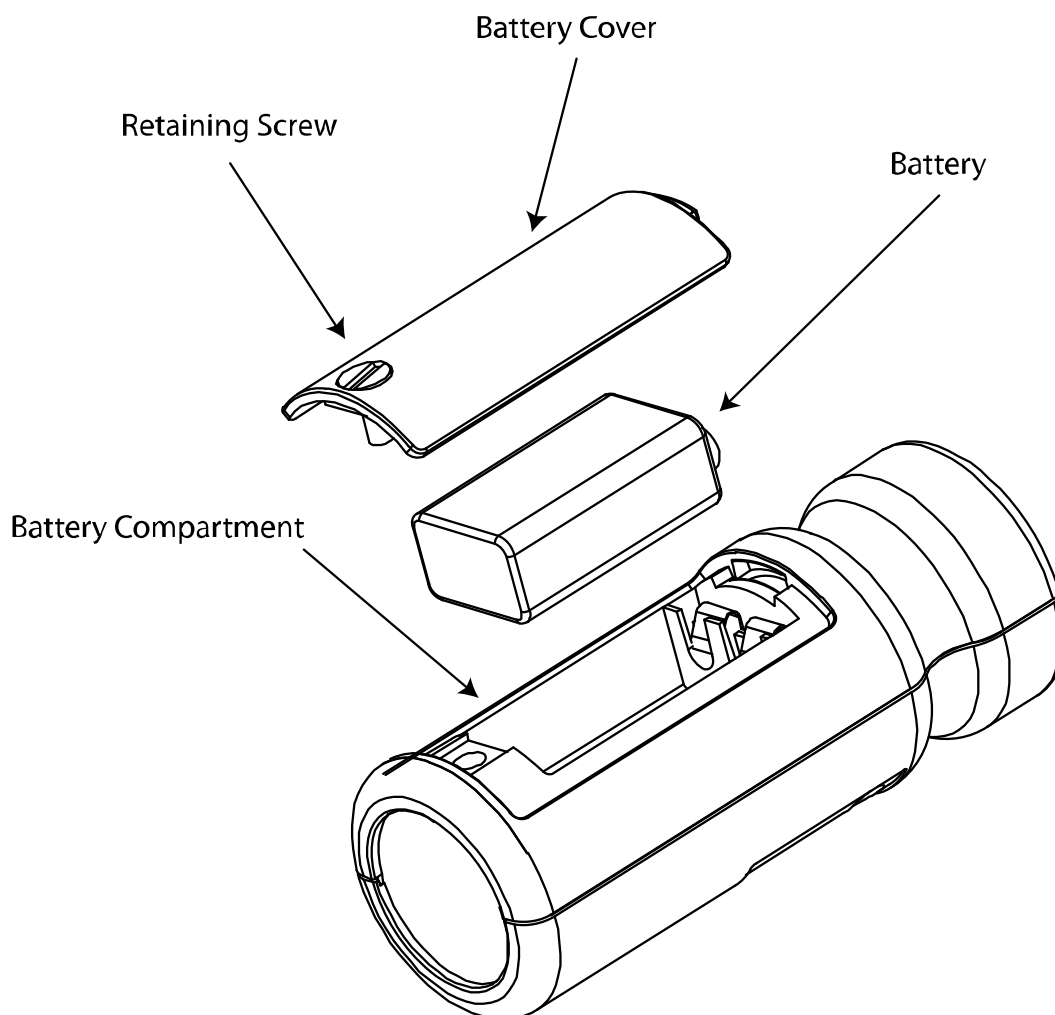

### Battery type.

The battery should be an alkaline battery, not an ordinary dry cell. The battery is 9 volts when new and will operate the calibrator down to 6.4 volts. When the battery voltage is below 6.6 volts but above 6.4 volts, the power LED will flash to indicate that the battery voltage is low. When the battery voltage is below 6.4 volts the calibrator will not turn on. A discharged battery may allow switch-on but will soon drop in voltage and indicate low battery or switch off.

**Specification.**

Frequency	1kHz $\pm$ 1%
Sound Level	94dB re 20 $\mu$ Pa
Standardisation	CR:514 - IEC 60942:2003 Class 2 CR:515 - IEC 60942:2003 Class 1
Distortion	Less than 2%
Operating Humidity	25 to 90% Relative Humidity
Operating Static Pressure	65 kPa to 108kPa
Operating Temperature	-10°C to +50°C
Storing Temperature	-20°C to +60°C
Effective Volume	6.19 cm <sup>3</sup> $\pm$ 0.2 cm <sup>3</sup>
Cavity Diameter	0.525 inch
Battery	1 x 9v 6F22 (Neda 1604)
Battery Life	Approx 15 Hours Continuous Use
Battery Voltage	9v Nominal (10v Maximum, 6.4v Minimum)
Weight with Battery	185g
Dimensions	135mm x $\varnothing$ 48mm

---

**Technical Information**

The normal mode of operation of the calibrator is with the unit switched on.

When the LED indicates the unit is switched on this produces the greatest radio frequency emissions.

The calibrator continues to function after exposure to contact discharges up to 4kV and air discharges up to 8kV, for both positive and negative voltages relative to earth ground.

The calibrator conforms to IEC 60942:2003 for a modulated root-mean-square electromagnetic field strength of 10 V/m.

The maximum susceptibility to power and radio frequency fields is with the cavity facing away from the emitter with the battery compartment facing the table, the antenna polarisation horizontal and the calibrator switched on.

---

## Free Field Correction

When calibrating a microphone which is to be used for free field measurements, a small correction may be necessary to compensate for the difference between the microphone's free field response at 'zero degrees' or 'head-on' incidence and the pressure level generated by the calibrator.

The correction is typically -0.3dB for ½ inch microphones (making the effective calibration level 93.7dB).

The table below shows the correction values for the standard microphones of Cirrus Research plc.

Calibration corrections are listed below for the Cirrus Research plc ½" Capsules and three microphone capsules commonly used in Calibration Laboratories:

### Microphone Correction Values

<b>Microphone Type</b>	<b>Calibration Correction</b>	<b>Effective Calibration Level</b>
<b>MK:202</b>	<b>-0.3dB</b>	<b>93.7 dB</b>
<b>MK:215</b>	<b>-0.3dB</b>	<b>93.7 dB</b>
<b>MK:216</b>	<b>-0.3dB</b>	<b>93.7 dB</b>
<b>MK:226</b>	<b>-0.3dB</b>	<b>93.7 dB</b>
<b>MK:224</b>	<b>-0.3dB</b>	<b>93.7 dB</b>
B&K 4134	0dB	94.0 dB
B&K 4180	0dB	94.0 dB
B&K 4192	0dB	94.0 dB

### Example

An example of the procedure used to calculate the value for an MK:224 microphone is shown below :

Level = 94.0dB + Microphone Correction

Level = 94.0dB + ( -0.3dB)

Level = 93.7dB

Different microphones will have different correction values. Please check the operation manual for the Sound Level Meter or microphone concerned for details.

---

## Appendix 5 Software Installation

The CR:800B Series are supplied with the Deaf Defier3 software on a CD-ROM.

Deaf Defier3 is suitable for PC's running Microsoft Windows 95 or later, including WindowsXP and Windows2000. Deaf Defier3 is supplied on CD-ROM, with a full installation program, and comprehensive on line help, which gives details of the options and functions of the software, along with details of the calculations used in the Hearing Protector Selection Report.



Please note that for PC's running Windows 95, 98 and 98SE, the Deaf Defier3 software may need to install additional components to enable the database to function correctly. These components are included with the installation program.



Please also note that full administrator access may be required to install the Deaf Defier3 software under WindowsXP, Windows2000 or WindowsNT. Contact your system administrator for further details.

To install the software, insert the CD-ROM into a CD-ROM drive on the PC. The installation program should automatically start.

If the installation program does not automatically start run D:\setup.exe where D is the drive letter of the CD-ROM drive on the PC.

### System Requirements

The Deaf Defier3 for Windows requires the following:

Microsoft Windows95, Windows 98, Windows 98 Second Edition, Windows ME, Windows NT Workstation 4.0 with service pack 6, Windows 2000 Professional with service pack 2, Windows XP Home Edition or Professional  
Internet access for downloading software updates  
6Mb of available hard disk space for program files  
64Mb RAM (128Mb recommended)  
CD-ROM Drive for Installation  
VGA or higher resolution monitor, Super VGA Recommended  
Microsoft compatible mouse or pointing device  
9 Pin RS232 (Serial) Port

### Installation Requirements

Cirrus Research plc accepts no responsibility for the installation of the Deaf Defier3 software where the system requirements are not fully met and where the user does not have the correct configuration or access rights to enable the software to install correctly.

Microsoft® is a registered trademark of the Microsoft Corporation. Windows 95™, Windows98™, Windows ME™ and Windows XP™ are registered trademarks of the Microsoft Corporation.

## Appendix 6 Configuring the instrument from the software

The configuration of the instrument can be set from within the Deaf Defier3 software.

Different configurations can be saved and loaded into the instrument to suit different measurement applications and standards. The following parameters can be set from within the Deaf Defier3 software:

- Measurement Mode
- Run Duration
- Time Weighting
- Frequency Weighting
- Measurement Range
- User Metric
- Measurement Auto Synchronisation
- Measurement Auto Repeat
- Ln values

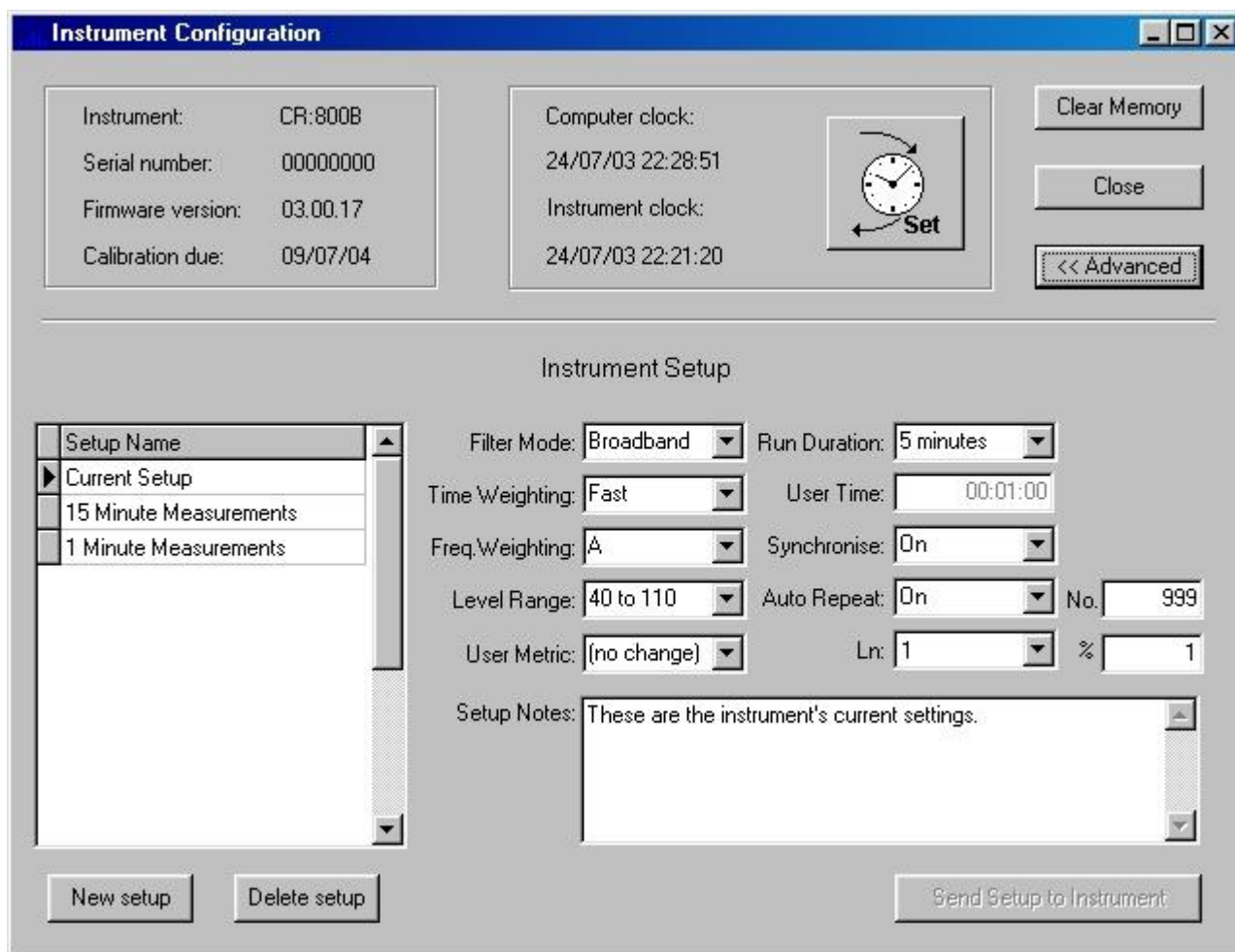

For full details, please refer to the Deaf Defier3 software help.



## Appendix 7 CE Certificate of Conformity

### Cirrus Research plc Hunmanby UK CE Certificate of Conformity



Manufacturer: Cirrus Research plc  
Acoustic House, Bridlington Road  
Hunmanby, North Yorkshire, YO14 0PH  
United Kingdom  
Telephone +44 1723 891655

#### Equipment Description

The following equipment manufactured after 1<sup>st</sup> January 2007:

CR:811B Sound Level Meter  
CR:812 Sound Level Meter  
CR:821 Sound Level Meter  
CR:822 Sound Level Meter  
CR:831 Sound Level Meter  
CR:832 Sound Level Meter  
CR:514 Acoustic Calibrator  
CR:515 Acoustic Calibrator

Along with their standard accessories

According to EMC Directives 89/336/EEC and 93/98/EEC

meet the following standards

#### **EN 61000-6-3 (2001)**

EMC : Generic emission standard for residential, commercial and light industrial environments.

#### **EN 61000-6-1 (2001)**

EMC : Generic immunity standard for residential, commercial and light industrial environments.

Signed

Dated 1<sup>st</sup> January 2007

A handwritten signature in black ink, appearing to be 'S. O'Rourke', written over a horizontal line.

S. O'Rourke  
Director

## Warranty Information.

1. This document is a summary of the full warranty document and explains the Cirrus Research plc warranty in ordinary English; not in legal or complex terms.
2. The warranty covers any acoustic instrument such as a sound level meter, acoustic calibrator, real time acoustic analyser or personal sound exposure meter (dosemeter) manufactured by Cirrus Research plc after September 1st 2011.
3. The warranty covers all faults on, and minor accidental damage to, the instrument except the microphone capsule for the period defined in para (5) below.
4. Minor accidental damage does not include blatant miss-use, damage caused by the use of any accessories or components not specified or recommended by Cirrus, damage caused through non-Cirrus modification, continued use outside of Cirrus' recommended procedure or conditions or use contrary to the any advice provided by Cirrus.
5. The initial period of the warranty is 2 (two) years or 104 weeks from the date of purchase as a new instrument from Cirrus Research plc or their formally approved distributors OR 130 weeks from the date the instrument passed its final manufacturing inspection at Cirrus Research plc - whichever is the shorter.
6. A shorter 1 (one) year or 52 week warranty is offered for used, ex-demo or ex-rental equipment unless a special arrangement is made and a written confirmation of the special warranty is given by Cirrus Research plc.
7. Any rechargeable battery only has the battery manufacturer's one year warranty, however there will be a reduced charge for their replacement during the annual "Traceable Calibration."
8. On completion of the annual "Traceable Calibration" by Cirrus Research plc, or an official Cirrus Calibration Centre, the instrument will automatically be given an additional free one year warranty.
9. It follows that should the instrument be calibrated by Cirrus Research plc, or an official Cirrus Calibration Centre every year, the warranty is effectively continuous to a maximum of 15 (fifteen) years from the date of purchase.
10. There will be a charge for this "Traceable Calibration" and the price is published in the Calibration Price List. The customer is responsible for all shipping, duty and other charges relating to the annual "Traceable Calibration".
11. Where a repair service is conducted under warranty, Cirrus Research plc will cover the shipping, duty and other costs relating to the repair of the instrument.
12. Cirrus Research endeavors to ensure stocks of instrument components for the full fifteen year period but do not guarantee to do so as certain components do become obsolete or discontinued.
13. If a sub-component becomes obsolete and stocks are depleted then Cirrus Research will endeavor to facilitate a repair but will not offer the same length warranty.
14. In the event of any dispute on the terms of the warranty Cirrus Research plc will accept pendulum arbitration by the United Kingdom Institute of Acoustics Ltd.
15. The warranty does not in any way reduce any legal right of the buyer or user of the sound level meter; it is in addition to all legal rights determined by the European Union.
16. Cirrus Research plc reserves the right to amend or update these terms and conditions without prior notice.

## Cirrus Research Offices

The addresses given below are the Cirrus Research plc offices. Cirrus Research plc also have approved distributors and agents in many countries worldwide. For details of your local representative, please contact Cirrus Research plc at the address below. Contact details for Cirrus Research authorised distributors and agents are also available from the Internet Web site at the address shown below.

### Main Office

Cirrus Research plc  
Acoustic House  
Bridlington Road  
Hunmanby  
North Yorkshire  
United Kingdom  
YO14 0PH

Telephone: +44 (0)1723 891655  
Fax: +44 (0)1723 891742  
E-mail: [sales@cirrusresearch.co.uk](mailto:sales@cirrusresearch.co.uk)  
Web Site: [www.cirrusresearch.co.uk](http://www.cirrusresearch.co.uk)

### Germany

Cirrus Research plc Deutschland  
Arabella Center  
Lyoner Strasse 44 – 48  
D-60528 Frankfurt  
Germany

Tel: +49 (0)69 95932047  
Fax +49 (0)69 95932049

Email: [vertrieb@cirrusresearch.de](mailto:vertrieb@cirrusresearch.de)  
Web: [www.cirrusresearch.de](http://www.cirrusresearch.de)

### Spain

CIRRUS RESEARCH S.L.  
Travessera de Gracia, 62 4º 7ª  
08006 Barcelona  
SPAIN

Tel: (34) 933 622 891  
Email: [info@cirrusresearch.es](mailto:info@cirrusresearch.es)  
Web: [www.cirrusresearch.es](http://www.cirrusresearch.es)

### Cirrus Environmental

Unit 2 Bridlington Road Industrial Estate  
Hunmanby  
North Yorkshire  
YO14 0PH  
United Kingdom

Tel: +44 (0) 1723 891722  
Email: [sales@cirrus-environmental.com](mailto:sales@cirrus-environmental.com)  
Web: [www.cirrus-environmental.com](http://www.cirrus-environmental.com)