

MATRIX

IC7

MODEL NO:IC-MXIC7B-01

**MANUFACTURED BY:**

Indoorcycling Group GmbH  
Happurger Str. 86  
90482 Nuremberg | Germany  
[info@indoorcycling.com](mailto:info@indoorcycling.com)  
[www.indoorcycling.com](http://www.indoorcycling.com)  
Phone: +49(0)911 / 54 44 50



**CAUTION!**

READ ALL PRECAUTIONS AND INSTRUCTIONS IN THIS MANUAL BEFORE YOU START USING THIS EQUIPMENT. PLEASE KEEP THIS MANUAL FOR FUTURE REFERENCE. IMPROPER ASSEMBLY, USE OR MAINTENANCE CAN VOID THE WARRANTY TERMS.

ADDITIONAL LANGUAGES AVAILABLE FOR DOWNLOAD AT [WWW.INDOORCYCLING.COM](http://WWW.INDOORCYCLING.COM)  
Version 1.0 2014 IC-MXIC7B-01 Copyright by Indoorcycling Group GmbH 2014 | [www.indoorcycling.com](http://www.indoorcycling.com)



# TABLE OF CONTENTS

**IMPORTANT PRECAUTIONS P.3**

**GETTING STARTED P.4**

**HOW TO ASSEMBLE THE INDOOR CYCLE P.5-9**

**INSTALLATION AND DISPOSING OF BATTERIES P.10-11**

**HOW TO ADJUST THE INDOOR CYCLE P.12-14**

**HOW TO OPERATE THE INDOOR CYCLE P.15**

**PREVENTIVE MAINTENANCE P.16-19**

**MAINTENANCE ACTIVITY AND REQUIRED SCHEDULE P.20-21**

**SPARE PARTS P.22-34**

**WARRANTY P.35**

## **TECHNICAL SPECIFICATIONS:**

The Matrix IC7 indoor cycle is, according to EN ISO 20957 (1 & 10), a Class S product for use in a controlled environment such as sports or fitness facilities under the supervision of a trainer.

<b>WEIGHT OF BIKE:</b>	<b>54 KG</b>
<b>MAX USER WEIGHT:</b>	<b>150 KG</b>
<b>USER HEIGHT:</b>	<b>SUITABLE FOR USERS BETWEEN APPROX. 155 AND 215 CM</b>
<b>REQUIRED FOOT PRINT:</b>	<b>APPROX. 132 X 52 CM</b>
<b>MAX SADDLE &amp; HANDLEBAR HEIGHT:</b>	<b>APPROX. 120 CM</b>

## **WARNING!**

The performance data shown on the display exceeds the requirements according to DIN EN 957-5 for Class A ergometers. The average achieved accuracy of  $\pm 1\%$  relates to a rotational speed range of 40 - 120 RPM and a braking efficiency of between 50 - 900 watts.

Electronic components adhere to the EMV Directive 204/108/EC, EMV Directive 99/519/EC, and DIN EN 60335-1 for electrical safety.

# IMPORTANT PRECAUTIONS

## WARNING!

To reduce the risk of serious injury due to improper use of the equipment, carefully read and adhere to the following important precautions and information before operating the indoor cycle!

1. It is the responsibility of the owner to ensure that all users are informed of all warnings and precautions for proper use, and are only authorized to use the bike independently after being successfully briefed by a qualified trainer or instructor.
2. Do not operate the bike until it has been properly assembled and inspected as described in this manual.
3. Keep the indoor cycle indoors, away from moisture and dust. Do not place the indoor cycle outdoors in a garage or covered patio or near water or pools. Operating temperature of the indoor cycle has to be between 15°C~40°C Celsius (59°~104°F) at max. humidity of 65%.
4. Always place the bike on a stable, level surface. If the bike is to be placed on a hardwood floor or carpet, it is recommended to place a floor mat beneath the bike, to protect the floor from becoming damaged.
5. The level of safety of the indoor cycle can only be guaranteed if it is regularly checked for possible damage as well as wear and tear (e.g. fixing points, E-Brake, Pedals, toe straps, etc.). Consult an authorized service provider or the manufacturer direct to ensure the regular inspections are properly carried out.
6. Carry out all maintenance, care and service procedures as described in this manual on a regular basis. Defective parts must be replaced immediately, and the device must not be used until the repairs have been carried out.  
Only use original parts from the manufacturer. Repairs must only be carried out by from manufacturer authorized service technicians.
7. Unsupervised children should be kept away from the training device at all times.
8. Children under the age of 14 shall only be allowed to use the indoor cycle with parental approval and supervision of a qualified Trainer or Instructor. Use of the bike by persons over the age of 14 only after they are briefed by a qualified trainer or instructor.
9. The indoor cycle must not be used by persons exceeding weight of 330 lbs/150 kg.
10. Always wear appropriate tight-fitting cycling or athletic attire and sturdy shoes, preferably cycling shoes, while operating the bike. Unfastened shoelaces may become caught in the drive system and lead to injury.
11. The indoor cycle does not have an independently-moving flywheel. The pedals will continue to move with the flywheel until the flywheel stops. The movement can only be stopped by using the emergency brake or by reducing the pedaling frequency in a controlled manner. Always ride with resistance load to ensure that your pedaling motion is controlled. Do not adjust handlebar or saddle during workout.  
Do not pedal backwards.
12. If you feel pain or dizziness while exercising, stop immediately. It is recommended that you consult a doctor if the pain does not subside for an extended period of time.
13. All data shown on the display, especially the Watt values generated by the integrated power sensor serve merely as information and to help guide training. Only exercise within your physical limitations.

## WARNING!

If you have pre-existing health problems or a disability, it is recommended that you consult your physician, in order to find the training method which is best suited to you. Incorrect or extensive training can result in serious health injuries.

The manufacturer expressly assumes no responsibility for health risks, personal injury, property damage or consequential damages sustained by or through the use of this device, unless it is a case of consequential damage which can be traced back to faulty material and/or manufacturing, and which come under the responsibility of the manufacturer.

# GETTING STARTED

## DEAR CUSTOMER,

We would like to thank you for your confidence and purchase. With the Matrix indoor cycle, you have chosen a high-quality product, which is designed according to the latest technical developments and thus fulfils the highest standards in quality and reliability.

This high level of reliability can however only be ensured with regular care and maintenance. Adhering to the maintenance procedures outlined in this manual will ensure a maximised stability and prolonged lifespan in return for minimal maintenance effort. This will guarantee long-standing, interruption-free operation.

Instructions on operation and managing training for the Coach-by-Color® computer can be found in the computer user manual also included with delivery.

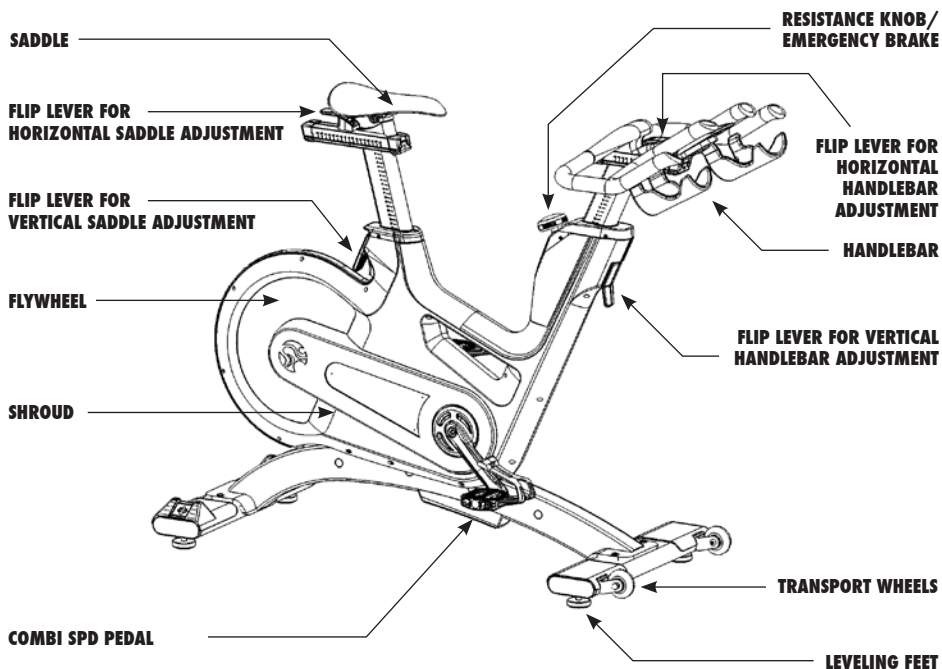

## WARNING!

You will find the production code for the Matrix IC7 indoor cycle on the tag plate which is located on the lower left side of the frame tube of the Indoor Bike. Please enter this production code into care and maintenance lists. It is a strict requirement to provide the production code in all warranty claims.

# HOW TO ASSEMBLE THE INDOOR CYCLE

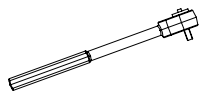

**TORQUE WRENCH**

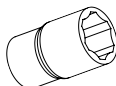

**17MM**



**2  
PEOPLE**

## **WARNING!**

Avoid high fluctuations in temperature whilst transporting the bike from the store to the installation site. If there are nevertheless large fluctuations in temperature, please allow the bike to acclimatise to the surrounding temperature before proceeding with assembly.

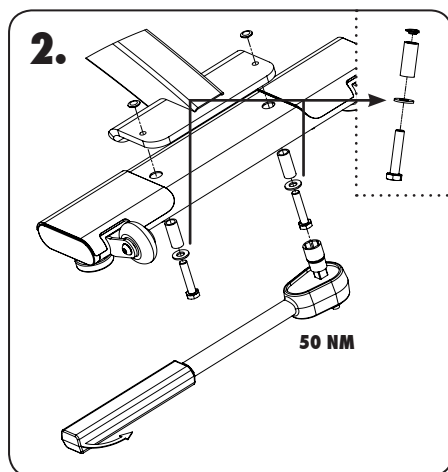
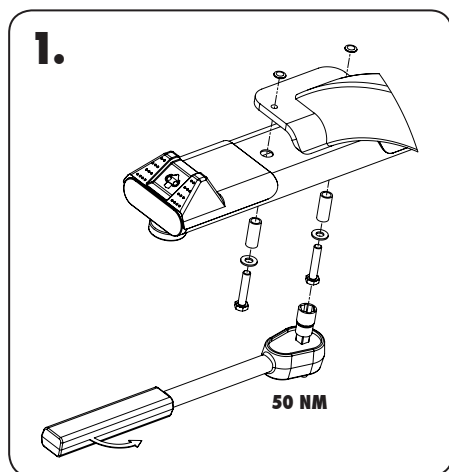

## **WARNING!**

Please ensure that bolts are tightened with significant force to minimize loosening during use. If bolts are loosened after initial assembly, we recommend using medium-strength LOCTITE® 243 when reassembling.

# HOW TO ASSEMBLE THE INDOOR CYCLE



2  
PEOPLE

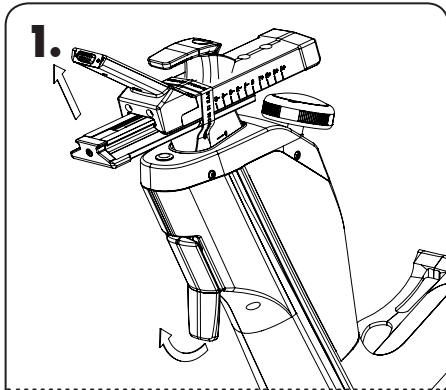

**1.**  
SET THE VERTICAL ADJUSTMENT OF THE HANDLEBAR STEM TO THE HIGHEST POSITION BEFORE BEGINNING WITH ASSEMBLY.

**DO NOT REMOVE WARNING TAPE FROM THE SLIDERS PRIOR TO THE HANDLEBAR BEING ASSEMBLED.**

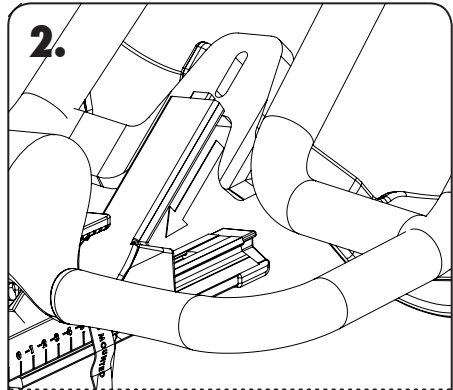

**2.**  
MAKE SURE THAT THE CONNECTING BRIDGES OF THE HANDLEBARS ARE LOCATED UNDERNEATH THE MOUNTING BRACKET FOR THE COMPUTER.

# HOW TO ASSEMBLE THE INDOOR CYCLE

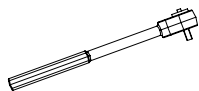

TORQUE WRENCH

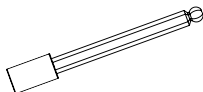

6MM



2  
PEOPLE

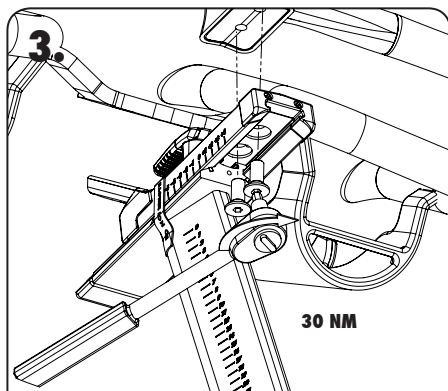

**IN ORDER TO AVOID DAMAGING THE INTERIOR CABLING, THE HANDLEBARS MUST NOT BE ADJUSTED HORIZONTALLY BEFORE THIS STEP.**

**ENSURE THAT BOLTS ARE TIGHTENED WITH SUFFICIENT FORCE (30 NM) WHEN MOUNTING THE HANDLEBARS.**

**THE FASTENING COUNTER SUNK BOLTS ARE COATED WITH TUFLOK® AT THE FACTORY TO PREVENT THEM FROM BECOMING LOOSE DURING USE.**

**IF BOLTS ARE LOOSENED AFTER INITIAL ASSEMBLY, WE RECOMMEND USING HIGH-STRENGTH LOCTITE® 2701 WHEN REASSEMBLING.**

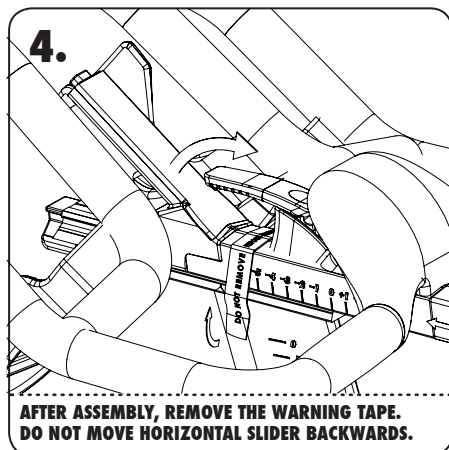

**AFTER ASSEMBLY, REMOVE THE WARNING TAPE. DO NOT MOVE HORIZONTAL SLIDER BACKWARDS.**

# HOW TO ASSEMBLE THE INDOOR CYCLE

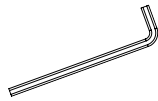

3MM



HAND TIGHT



2  
PEOPLE

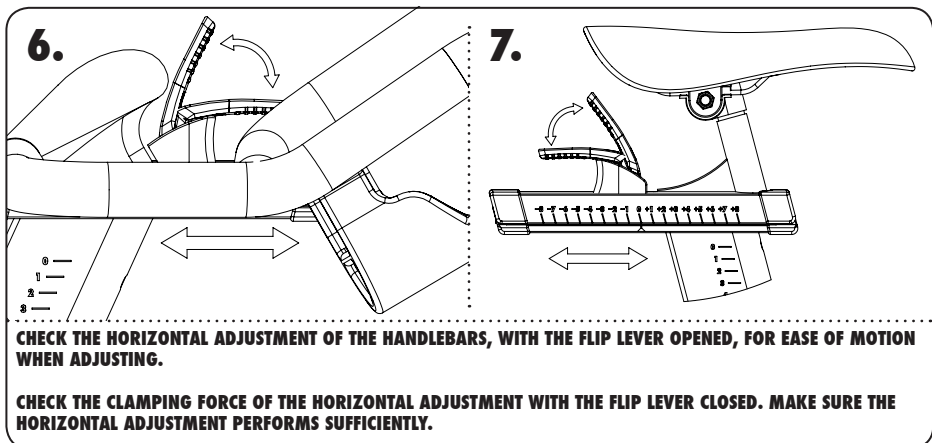
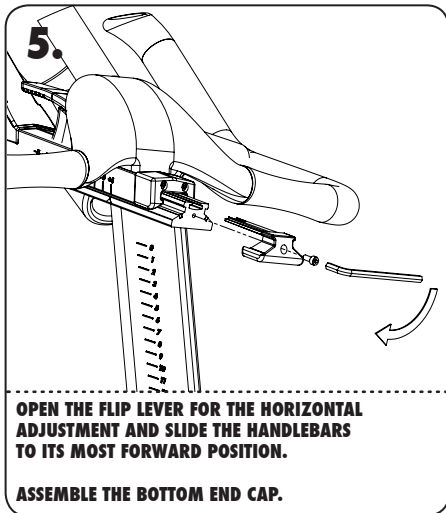



# HOW TO ASSEMBLE THE INDOOR CYCLE

1X

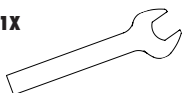

15 MM  
PEDAL WRENCH

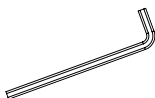

3MM



HAND TIGHT

2  
PEOPLE

8.

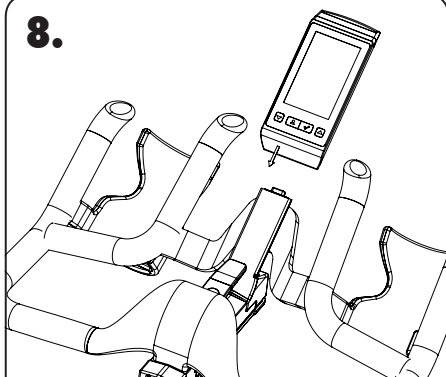

INSERT THE BIKE COMPUTER  
INTO THE COMPUTER BRACKET.

9.

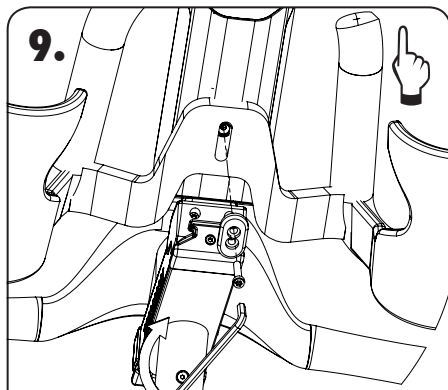

FASTEN THE BIKE COMPUTER INTO PLACE FROM  
THE UNDERSIDE OF THE HANDLEBARS WITH  
THE BOLT AND PLASTIC SLEEVE PROVIDED.

## WARNING!

The user manual for the IC7 Coach By Color® computer is enclosed separately and contains all the necessary information for setting up and operating the computer.

10.

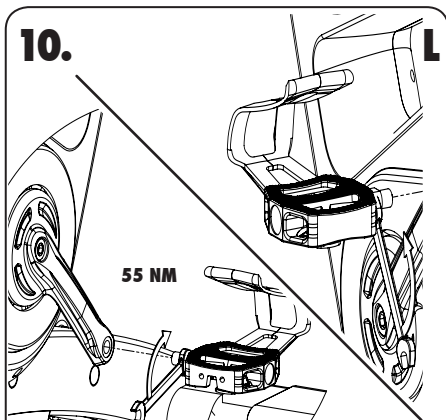

55 NM

R

OBSERVE ASSEMBLY  
INSTRUCTIONS!

## WARNING!

Attach the pedal marked **R** on the right crank and tighten by turning clockwise (standard right-hand thread). Attach the pedal marked **L** on the left crank and tighten by turning counter-clockwise (left-hand thread). Please make sure that both pedals are fastened with sufficient force (55 NM), to ensure that the bolt does not become loose during use.

The threads are provided with TufLok® at the factory to prevent them from becoming loose during use. If bolts are loosened after initial assembly, we recommend using medium-strength LOCTITE® 243 when reassembling.

# INSTALLATION AND DISPOSING OF BATTERIES

Instructions stated in this manual must be performed during initial installation of the Matrix indoor cycle in order to ensure optimal performance and a long lifespan. Please read and follow the following instructions carefully. If the indoor cycles are not installed and configured as described, the components may be subjected to excessive wear and tear and the bike may become damaged. If you have any questions regarding installation, please contact [service@indoorcycling.com](mailto:service@indoorcycling.com).

**Please note:** Lubricants are required for some maintenance procedures. Please only use an **acid- and solvent-free spray lubricant** (e.g. Brunox) and white lithium grease.

- 1.** Make sure the bike is level. If bike rocks on the floor, turn the levelling feet underneath the front and/or rear stabilizer until the rocking motion is eliminated. Make sure that the levelling feet are not screwed out further than 10 mm.
- 2.** Verify emergency brake function to make sure that it is working properly.
- 3.** Check that both crank arm Allen bolts, with which the cranks (on the right and left side of the bottom bracket) are fastened, are secure (tightening torque 60 NM). These bolts are provided with TufLok® at the factory to prevent them from becoming loose during use.

If the bolts become lose, we recommend applying medium-strength LOCTITE® 243 and then reattaching the crank fixing bolts with a tightening torque of 60 NM.

- 4.** Wipe down bike frame with a rag moistened with solvent-free spray lubricant.
- 5.** Some parts of the bike may become loose during shipment. Check crank arms and all exposed screws, bolts and nuts, and make sure that they are all secure and properly tightened.

# INSTALLATION AND DISPOSING OF BATTERIES

## CUSTOMER SERVICE

1. Provide the customer with basic maintenance instructions, and direct them to detailed maintenance instructions.
2. Have the sign-off sheet for the manual, explanation of maintenance procedures and verification of impeccable condition of the bikes confirmed by the customer when handing over the goods. A copy of this confirmation counter-signed by yourself is withheld by the customer.
3. Repairs must only be carried out by manufacturer authorised service technicians.

## BATTERIES MAY NOT:

- come into contact with fire
- come into contact with coins or other metallic objects

If the device remains unused for an extended period of time, remove the battery in order to avoid damage due to leakage or corrosion. If the battery leaks, remove all residues immediately and insert a new battery. If you make contact with any residues, carefully remove them.

Products or batteries labelled with this symbol may not be disposed of along with normal household refuse. For proper disposal, please find out about the applicable laws or guidelines on disposing of electrical devices and batteries in your local area and adhere to them.



# HOW TO ADJUST THE INDOOR CYCLE

The Matrix indoor cycle can be very easily adjusted, depending on the requirements of various user groups. This enables maximum riding comfort to be ensured whilst achieving optimal training results. The configurations described in the following paragraphs demonstrate just a few of the most often used adjustment variations of which the indoor cycle is capable. It is up to the user to adjust the indoor cycle to a riding position best suited to their requirements.

## ADJUSTING THE SEAT HEIGHT:

Sit on the saddle and ensure that your hip is not tilted to one side when the pedal has assumed the position as shown in the picture. Place your shoes in the toe clips (cages) on the pedals, or in the SPD cleats if you are using cycling shoes, if your indoor cycle is not fitted with a combi pedal system.

### VERTICAL SADDLE ADJUSTMENT

OPEN

CLOSED

### VERTICAL HANDLEBAR ADJUSTMENT

OPEN

CLOSED

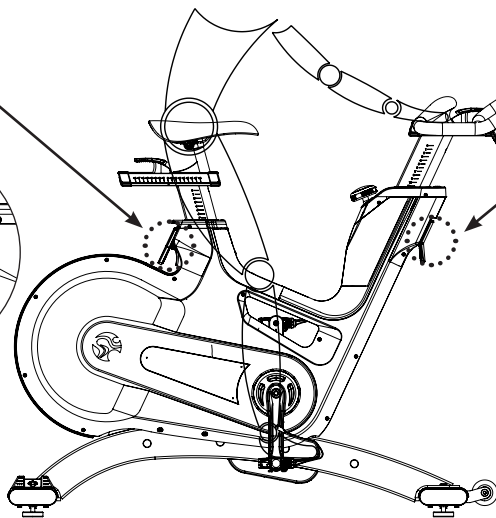

## WARNING!

Do not adjust seat and handlebar during exercise. Ensure that all flip levers (vertical and horizontal) are closed, before you sit on the bike and always step off the bike when making adjustments to the handlebars and/or saddle.

Start pedalling slowly, until the pedal has reached the position as shown in the picture. The vertical saddle sliders should be adjusted so that your knees are always slightly bent when this pedal position is reached, without dropping your hip one side. Rule of thumb: When standing next to the bike, the upper edge of the saddle should be a hand's width/four fingers below your iliac crest. Please avoid cycling with your knees fully extended or your hip tilted to one side.

# HOW TO ADJUST THE INDOOR CYCLE

## ADJUSTING THE SADDLE HORIZONTALLY:

Properly positioning the saddle horizontally is very important in order to avoid injury to the knees. Sit on the saddle and move the pedals until the crank arms are in the horizontal position.

The knee of your forward-facing leg should be positioned directly above the centre of the pedal. If this does not correspond to your bike's setting, please align the horizontal saddle adjustment to the front or rear in order to attain this seat position.

### HORIZONTAL SADDLE ADJUSTMENT

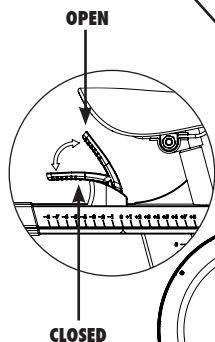

### HORIZONTAL HANDLEBAR ADJUSTMENT

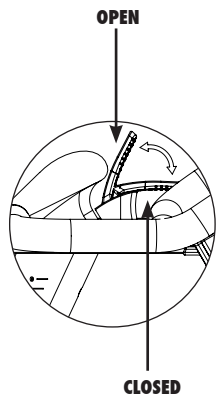

## WARNING!

Ensure that all flip levers (vertical and horizontal) are closed, before sitting on the bike and always step off the bike when making adjustments to the handlebars and/or saddle.

# HOW TO ADJUST THE INDOOR CYCLE

## HANDLEBAR POSITIONING:

Begin with the top of the handlebars at approximately the same height as the saddle (**dotted horizontal line A in the drawing below**) for inexperienced users set to the "0" marking (**see dotted vertical line B in the drawing below**). If your knees touch the handlebars or if you experience back discomfort when pedalling in the standing riding position for extended periods, the handlebars should first be adjusted slightly higher.

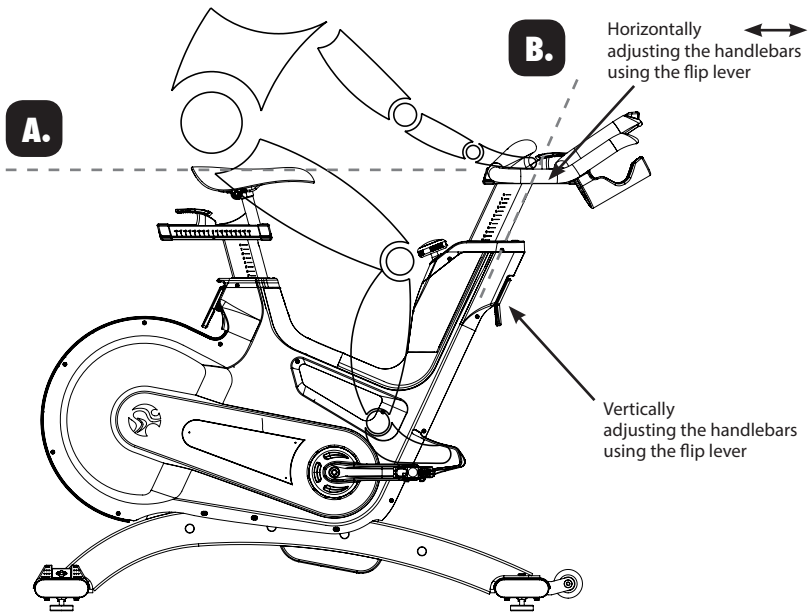

The next step is to adjust the horizontal position of the handlebars as precisely as possible to your height. An ideal and protective seating position for inexperienced riders is achieved if your back assumes an inclination at an angle of 45°.

The handlebars offer a wide variety of hand positions and adjustment possibilities, which provide the experienced rider with every possibility to find his/her ideal seating and hand positioning.

It is recommended to change hand positions frequently during extended workouts in order to minimise one-sided and monotonous exertions on your muscles, ligaments and joints.

# HOW TO OPERATE THE INDOOR CYCLE

## RESISTANCE ADJUSTMENT:

The resistance adjustment can be set precisely and regulated in fine increments according to the requirements of the cyclist using the resistance adjustment knob with a range of motion of 300°. The resistance in % (where 0% is no resistance and 100% is maximum resistance) is also displayed on the indoor cycle computer display.

To increase the resistance, turn the resistance adjustment knob clockwise. To decrease the resistance, turn it counter-clockwise. For a magnetic brake system, like the one fitted to this indoor cycle, the magnetic resistive effect also increases with pedalling frequency.

Never pedal backwards under resistance, as this can loosen the screws between the pedals and the crank arm and the two may even become detached. To stop the flywheel during use, the resistance knob/emergency brake knob must be pressed down. During training, please make sure your shoes are placed in the toe clips (cages) provided or if you are using cycling shoes, that they are connected with the SPD cleats.

The indoor cycle does not have a free-moving flywheel. The flywheel is firmly connected to the pedals and does not stop independently if the user stops pedalling. Please always check your movements and reduce speed in a controlled manner to stop or simply press the red resistance/emergency brake knob down to quickly slow down the movement and in so doing bring the flywheel to a stop and suspend the training session.

**Emergency brake = press down red resistance/emergency knob.**

**If the emergency brake has been activated, it can only be disengaged again when the flywheel has come to a complete standstill and the pressure has been removed from the pedals.**

## RESISTANCE KNOB (TURN RESISTANCE ADJUSTMENT KNOB)

## EMERGENCY BRAKE (PRESS RESISTANCE ADJUSTMENT KNOB)

For safety reasons, please always make sure you pedal in a controlled manner and adjust your pedalling frequency to your own cycling capabilities.

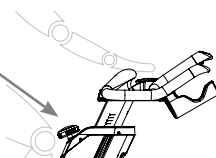

## MOVING THE INDOOR CYCLE:

It is recommended that 2 people move the indoor cycle. In order to prevent accidents and damage to the plug-in sockets of the handlebars it is necessary to firmly fix the vertical handlebar adjustment before the wheel is tilted. Please take extra care when moving the indoor cycle over uneven surfaces. A second person is advisable here, to prevent the cycle from tilting to one side.

**Allow a minimum safety distance away from the nearest equipment of at least 50 cm to the left and right and 90 cm to the front and rear.**

Check the stability of the indoor cycle where it is to be operated and if necessary adjust the levelling feet underneath the front or rear stabilizers to ensure the desired stability.

## IMPORTANT!

Please do not unscrew the levelling feet more than 1 cm!

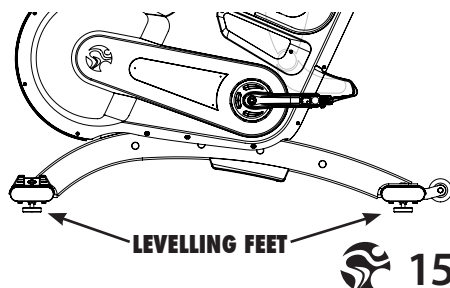

# PREVENTIVE MAINTENANCE

## WARNING!

Please carefully observe the following instructions. The maintenance and care procedures must be performed in the regularity set out, to ensure maximum operating safety and lifespan. Irregularly observed maintenance and care procedures will lead to increased wear to the product and will void the warranty. If you have any further questions on this topic, please contact our technical support.

Please only use the acid- and solvent-free maintenance and care agent (e.g. Brunox) recommended by us to prevent damage to components of the indoor cycle.

## DAILY MAINTENANCE:

**1.** Make sure that the indoor cycle is **leveled and does not rock** (if necessary adjust as described on p.15).

**2. Cleaning:** The indoor cycle must be regularly cleaned after each use for reasons of hygiene. Ensure that there are sufficient soft cloths or paper towels and maintenance and disinfection agent available. First disinfect the saddle and handlebars with a suitable agent and then wipe all bodily residues off the entire indoor cycle.

## WEEKLY MAINTENANCE:

**1. Cleaning:** Depending on how often the indoor cycle is used, it must be extensively cleaned once a week. To do this, spray a maintenance spray onto a soft cloth and clean all plastic parts, the entire flywheel, exposed framework parts including stabilizers and the plastic casing.

Never spray the maintenance spray directly onto the flywheel, as this could cause the drive belt to slip through (belt slip).



# PREVENTIVE MAINTENANCE

## BI-WEEKLY MAINTENANCE:

**1. Emergency brake:** To ensure operating safety, the emergency brake must be regularly checked to make sure it is functioning properly. To do this, press down the red emergency brake handle whilst pedalling. When functioning optimally, it should produce an immediate braking effect and bring the flywheel to a complete standstill.

The flywheel is only released again by the emergency braking function after coming to a complete standstill and when the pressure is removed from the pedals.

**2. Saddle adjustments:** To maintain the easy adjustment, the vertical and horizontal saddle posts must be regularly cleaned and lubricated. To do this, position the vertical saddle post (A) in the uppermost position, spray with maintenance spray and rub down the entire exterior surfaces including the horizontal post with a soft cloth.

Clean sweat residues off the contact surfaces (B) of the horizontal saddle post beforehand and if necessary apply a small amount of lithium/silicone grease.

Also apply some lithium/silicone grease as required to the clamp mechanism of the clamping lever of the horizontal post (C).

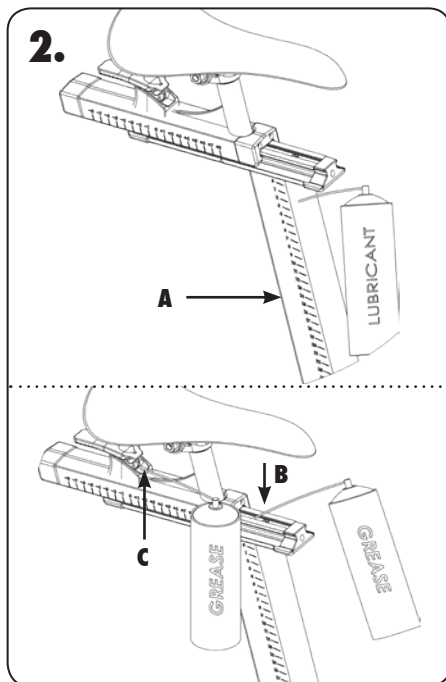
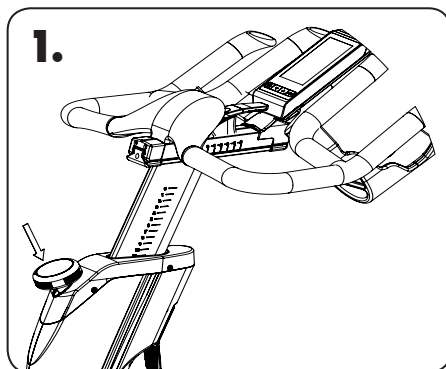

# PREVENTIVE MAINTENANCE

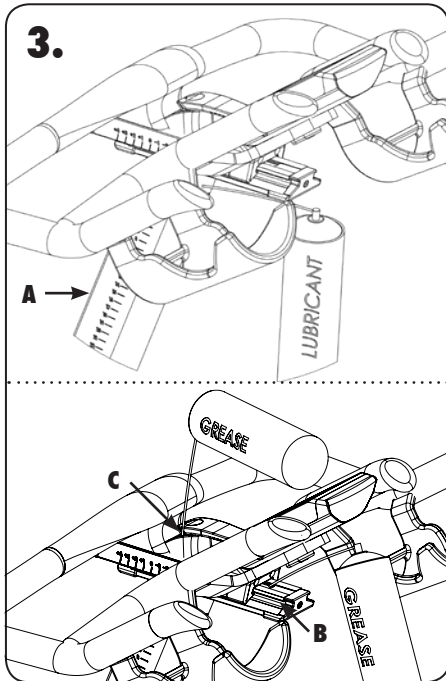

**3. Handlebars:** To maintain the easy adjustment of the handlebar posts, the vertical and horizontal handlebar posts must be regularly cleaned and lubricated. To do this, position the handlebars (**A**) in the uppermost position, spray the handlebar posts with maintenance spray and rub down the entire exterior surfaces including the horizontal post with a soft cloth. Clean sweat residues off the contact surfaces of the horizontal handlebar post (**B**) beforehand and if necessary apply a small amount of lithium/silicone grease.

Also apply some lithium/silicone grease as required to the clamp mechanism of the flip lever of the horizontal post (**C**).

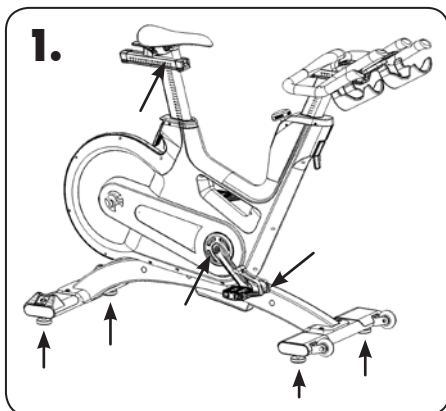

## MONTHLY MAINTENANCE:

**1. Connecting elements:** During the course of regular maintenance and care procedures, all bolts, nuts etc. on the indoor cycle must be checked for firm seating and function, and parts showing wear or damage (saddle, pedal teeth, pedals, SPD system) replaced.

# PREVENTIVE MAINTENANCE

## USER-DEFINED MAINTENANCE:

### 1. Vertically adjusting the handlebars and saddle:

To ensure the easy adjustment of the vertical handlebar and saddle posts, it is recommended that you check the clamping mechanism and if necessary apply a small amount of lithium/silicone grease to the vertical clamping mechanism of the handlebar posts (1) and saddle posts (2/3).

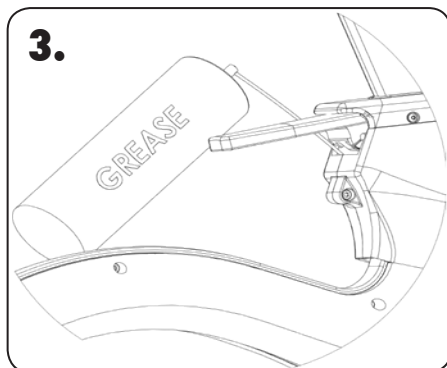
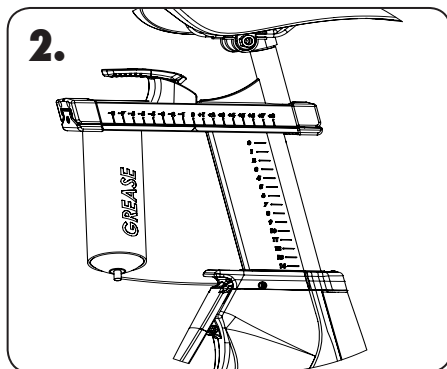
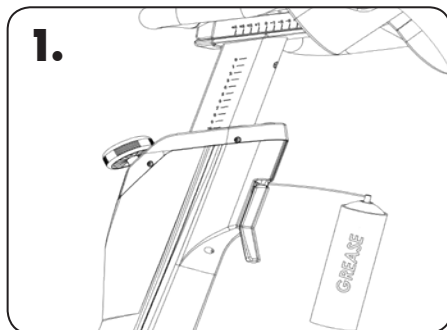

# MAINTENANCE ACTIVITY AND REQUIRED SCHEDULE

ACTIVITY	ROTATION	DETAILS
<b>FEET LEVELLING, DISINFECTION &amp; CLEANING OF THE BIKE</b>	<b>DAILY</b>	<b>P 16</b>
<b>SERVICING BRAKE PADS, DETAILED CLEANING OF THE ENTIRE BIKE</b>	<b>WEEKLY</b>	<b>P 16</b>
<b>CHECK EMERGENCY BRAKE FUNCTION</b>	<b>BI-WEEKLY</b>	<b>P 17</b>
<b>CLEAN AND LUBRICATE SADDLE &amp; HANDLEBAR SLIDERS / POSTS</b>	<b>BI-WEEKLY</b>	<b>P 17-18</b>
<b>CHECK ALL CONNECTIONS AND FIXINGS</b>	<b>MONTHLY</b>	<b>P 18</b>
<b>VERTICALLY ADJUSTING THE HANDLEBARS AND SADDLE</b>	<b>MONTHLY</b>	<b>P 19</b>

## EXAMPLES OF MAINTENANCE PLAN CHARTS FOR IN-HOUSE SERVICE TECHNICIANS:

WEEKLY MAINTENANCE CHECKLIST					
BIKE NO.	PRODUCTION CODE	OBSERVATIONS	ACTION TAKEN	RESULT	NAME / DATE

# MAINTENANCE ACTIVITY AND REQUIRED SCHEDULE

**BI-WEEKLY MAINTENANCE CHECKLIST**

BIKE NO.	PRODUCTION CODE	OBSERVATIONS	ACTION TAKEN	RESULT	NAME / DATE

**MONTHLY MAINTENANCE CHECKLIST**

BIKE NO.	PRODUCTION CODE	OBSERVATIONS	ACTION TAKEN	RESULT	NAME / DATE

# SPARE PARTS

## FRAME

**100-01-00004-01**

**INLAY SLEEVE SET FOR HANDLEBAR TUBE**

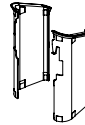

**100-01-00006-01**

**INLAY SLEEVE SET FOR SEATPOST TUBE**

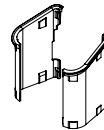

**100-01-00009-01**

**LEFT FLYWHEEL SUPPORT ARM KIT**

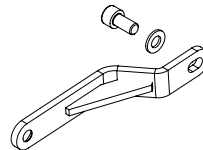

**100-01-00007-01**

**VERTICAL HANDLEBAR  
ADJUSTMENT ASSEMBLY**

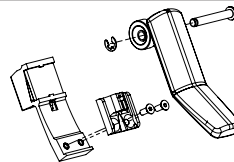

**100-01-00008-01**

**VERTICAL SEATPOST  
ADJUSTMENT ASSEMBLY**

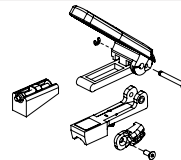

## SEAT/SEAT POST

**120-01-00005-01**

**LOWER  
SEATPOST ASSEMBLY**

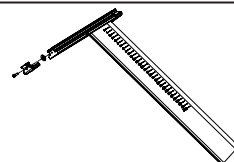

# SPARE PARTS

**120-01-00006-01**

**UPPER SEATPOST  
SLIDER ASSEMBLY**

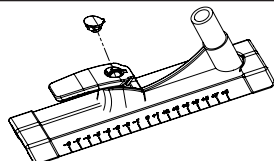

**120-01-00010-01**

**COMFORT SPORT SADDLE  
BLACK/RED INCL. SADDLE CLAMP**

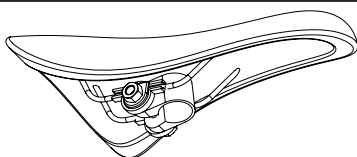

**180-01-00018-01**

**SEATPOST GASDAMPER KIT**

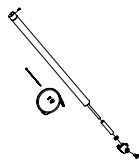

**180-01-00021-01**

**FLIP LEVER ASSEMBLY FOR  
HORIZONTAL SEATPOST ADJUSTMENT**

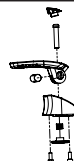

**190-01-00007-01**

**END CAP SET  
SEATPOST**

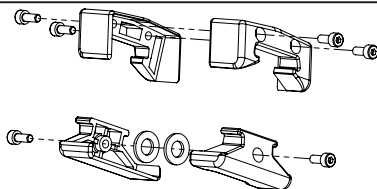

**190-01-00011-01**

**BOWDEN CABLE SPARE PART KIT FOR  
VERTICAL SEATPOST ADJUSTMENT**

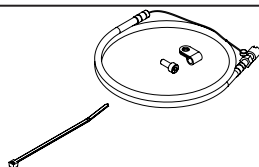

# SPARE PARTS

## HANDLEBAR/HANDLEBAR STEM

**110-01-00009-01**

**HANDLEBAR WITH SOFT PVC  
COATING & MOUNTING BOLTS**

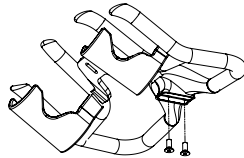

**110-01-00012-01**

**UPPER HANDLEBAR  
SLIDER ASSEMBLY**

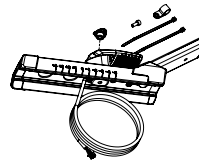

**180-01-00005-01**

**FLIP LEVER ASSEMBLY FOR  
HORIZONTAL HANDLEBAR ADJUSTMENT**



**170-01-00004-01**

**CONSOLE BRACKET ASSEMBLY**



**110-01-00011-01**

**CABLE COVER KIT FOR UPPER  
HORIZONTAL HANDLEBAR SLIDER**

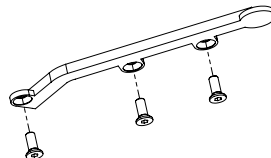

**110-01-00003-01**

**LOWER HANDLEBAR STEM ASSEMBLY**

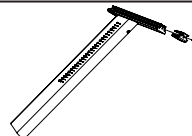



# SPARE PARTS

**180-01-00017-01**

**HANDLEBAR GASDAMPER KIT**

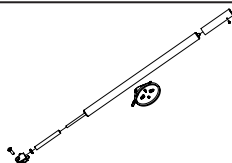

**190-01-00010-01**

**BOWDEN CABLE SPARE PART KIT FOR VERTICAL HANDLEBAR ADJUSTMENT**

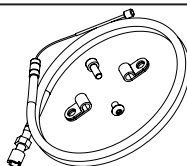

**190-01-00006-01**

**END CAP SET FOR HANDLEBAR**

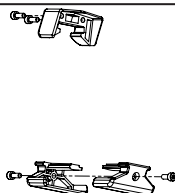

## BRAKE SYSTEM

**130-01-00011-01**

**UPPER BRAKE ASSEMBLY**

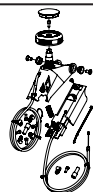

**130-01-00014-01**

**BRAKE DIAL KIT**

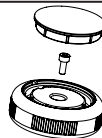

# SPARE PARTS

**190-01-00008-01**

**EMERGENCY BRAKE SPARE PART KIT**

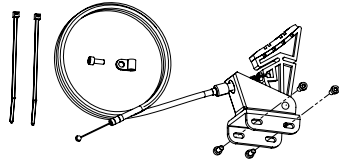

**190-01-00009-01**

**LOWER EDDY CURRENT BRAKE  
SPARE PART KIT**

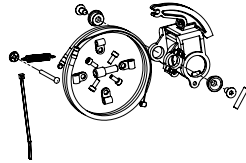

**190-01-00012-01**

**BOWDEN CABLE SPARE PART KIT  
FOR EMERGENCY BRAKE**

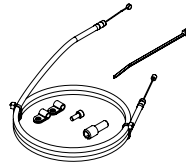

**190-01-00013-01**

**BOWDEN CABLE SPARE PART KIT  
FOR LOWER EDDY CURRENT BRAKE**

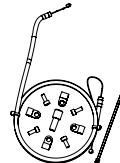

## DRIVE GEAR

**150-01-00022-01**

**CAM PULLEY  
72 TEETH KIT**

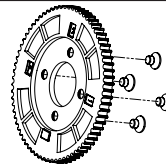

**150-01-00023-01**

**CRANK PULLEY  
MOUNTING BOLTS**

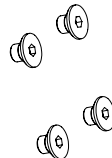

# SPARE PARTS

**150-01-00024-01**

**FLYWHEEL  
AXLE KIT**

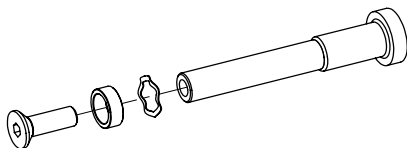

**900-00-90008-20**

**CRANK MOUNTING BOLT,  
M8X20X1,25P**

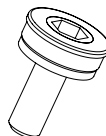

**190-01-00014-01**

**FLYWHEEL SPARE PART ASSEMBLY**



**150-03-00044-01**

**POLY V BELT,  
4PK 895 FOR SECONDARY DRIVE**

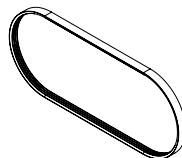

**150-03-00045-01**

**POLY V BELT,  
2PJ 330 FOR GENERATOR DRIVE**

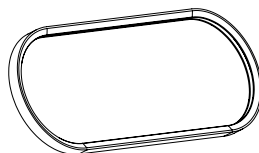

**150-03-00059-01**

**TIMING BELT,  
784 8MHL 12 FOR PRIMARY DRIVE**

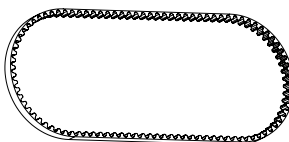

# SPARE PARTS

**150-01-00016-01**

**PRIMARY DRIVE IDLER PULLEY ASSEMBLY**

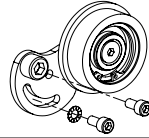

**150-01-00018-01**

**SECONDARY DRIVE IDLER PULLEY ASSEMBLY**

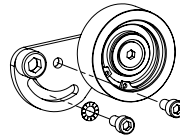

**150-03-00054-01**

**LEFT CRANK ARM, RED**



**150-03-00053-01**

**RIGHT CRANK ARM, RED**

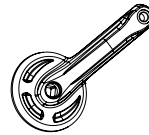

## ELECTRONICS

**170-01-00004-01**

**CONSOLE BRACKET ASSEMBLY**



**150-01-00017-01**

**GENERATOR ASSEMBLY**

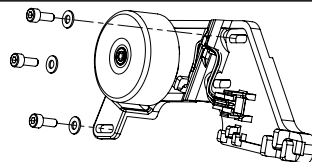

# SPARE PARTS

**170-01-00009-01**

**POWER MODULE  
PCB ASSEMBLY**

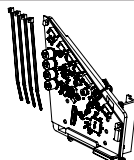

**170-01-00005-01**

**GEAR MODULE  
PCB ASSEMBLY**

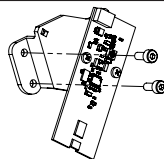

**170-01-00006-01**

**PHOTO INTERRUPTER  
PCB KIT**

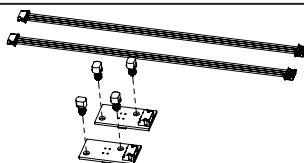

**170-01-00007-01**

**GAMMA SENSOR  
PCB ASSEMBLY**

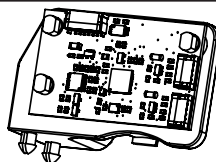

**170-01-00016-01**

**MAIN CABLE HARNESS SET WITH  
IDENTIFICATION STICKER**

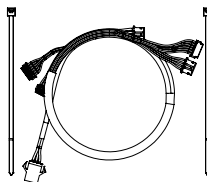

**170-01-00015-01**

**USB CABLE SET**

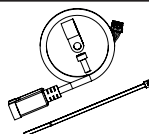

# SPARE PARTS

**170-03-00012-01**

**LIPO RECHARGEABLE BATTERY  
5000MAH/3.7V**

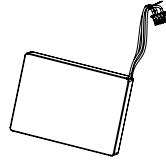

**320-00-00009-01**

**CONSOLE KIT**

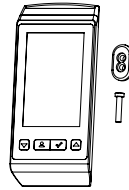

## SHROUD

**160-01-00004-01**

**RIGHT SIDE  
MAIN SHROUD KIT**

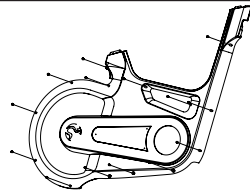

**160-01-00006-01**

**LEFT SIDE  
MAIN SHROUD KIT**

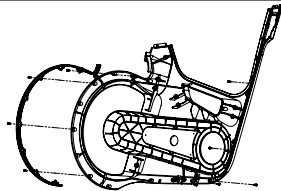

**160-01-00007-01**

**TOP  
MAIN COVER KIT**

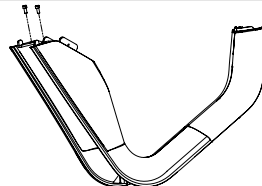

# SPARE PARTS

**160-01-00008-01**

**HANDLEBAR  
TOP COVER KIT**

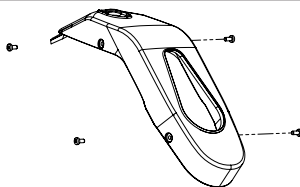

**160-01-00009-01**

**SEATPOST  
TOP COVER KIT**

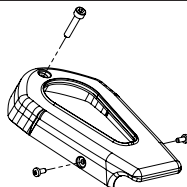

**160-01-00014-01**

**GAS DAMPER BRACKET  
COVER KIT**

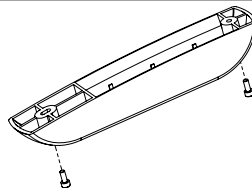

**160-09-00006-01**

**IC7 LEFT MAIN COVER  
ALUMINUM BADGE**

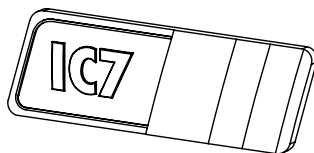

**160-09-00007-01**

**IC7 RIGHT MAIN COVER  
ALUMINUM BADGE**

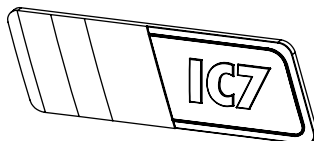

# SPARE PARTS

**160-01-00011-01**

**MATRIX LOGO PLATE  
INSERT KIT, RIGHT**



**160-01-00010-01**

**MATRIX LOGO PLATE  
INSERT KIT, LEFT**



## FRONT AND REAR STABILIZER

**140-01-00004-01**

**FRONT STABILIZER  
PROTECTION PLATE KIT, LEFT**

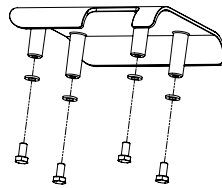

**140-01-00005-01**

**FRONT STABILIZER  
PROTECTION PLATE KIT, RIGHT**

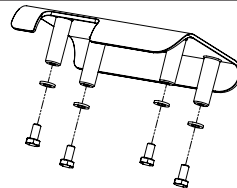

**140-01-00003-01**

**TRANSPORTATION WHEEL KIT**

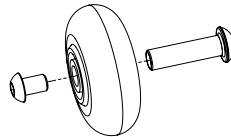

**140-03-00001-01**

**STABILIZER END CAP**

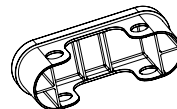



# SPARE PARTS

**900-10-00003-01**

**LEVELING FEET, RUBBER 75° SHORE**

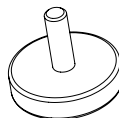

**190-01-00004-01**

**STABILIZER MOUNTING KIT**



**140-02-00006-01**

**FRONT STABILIZER TUBE**

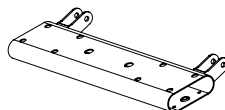

**140-01-00006-01**

**REAR STABILIZER  
STRETCH PLATE KIT**

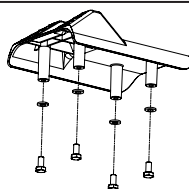

**140-02-00002-01**

**REAR STABILIZER TUBE**

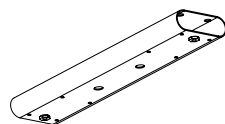

# SPARE PARTS

## PEDALS

**150-01-00005-01**

**COMBI PEDAL SET,  
SPD COMPATIBLE**



**150-03-00048-01**

**TOE STRAP SET**



# WARRANTY

ICG warrants that all new equipment will be free of manufacturing defects in workmanship and materials, effective on the date of original assembly at its production facility. Parts repaired or replaced under the terms of this warranty will be warranted for the remainder of the original warranty period only. ICG is obligated to uphold its manufacturer warranty obligation so long as the product is used in the closed environment it was designed for, temperature range between 15°C~40°C Celsius (59°F~104°F) and max. 65% humidity (not near a swimming pool or outdoors). Defects caused by obvious deliberate mechanical impact, inappropriate use or undo handling of the product may cause the manufacturer's warranty to become void. In order for the manufacturer to uphold the warranty coverage, the customer (fitness facility) is obligated to maintain and service the product as per the manufacturer's specifications stated in the owner manual of each product.

## 5 YEARS WARRANTY:

## 3 YEARS WARRANTY:

## 1 YEAR WARRANTY:

## FRAME CONSTRUCTION AND WELDING

### POWDER COATING (PAINT CRACKS, CORROSION)

### HANDLEBAR AND SEAT POST ASSEMBLY (ALUMINUM PARTS AND PVC COATING)

### DUAL BELT DRIVE SYSTEM

### POWER SENSOR

### BOTTOM BRACKET ASSEMBLY

### FLYWHEEL AND HUB ASSEMBLY

### CRANKS

### PEDALS (EXCLUDED BINDING SYSTEM AND STRAPS)

### INSERT SLEEVES FOR HANDLE BAR AND SEAT POST

### BOWDEN CABLES (BRAKE ADJUSTMENT, E BRAKE ACTIVATION, GAS DAMPER ACTIVATION CABLE SP & HB VERTICAL ADJUSTMENT)

### BRAKE SYSTEM

### GAS DAMPERS

### FLIP LEVER ASSEMBLY

### FOR HORIZONTAL AND VERTICAL ADJUSTMENT ( HB & SP)

### LEVELLING FEET

### SHROUD AND TOP COVERS

## ELECTRONIC COMPONENTS

### (CONSOLE, CABLE HARNESS, PCBs AND SENSORS, GENERATOR)

### LITHIUM POLYMER (LIPO) BATTERY

### SADDLE CONSTRUCTION (EXCLUDED STITCHING AND SADDLE SURFACE)

## THE FOLLOWING WEAR ITEMS ARE EXCLUDED FROM WARRANTY:

Pedal straps, pedal binding system, saddle surface.

## **CAUTION.**

READ ALL PRECAUTIONS AND INSTRUCTIONS IN THIS MANUAL BEFORE YOU BEGIN USING THIS EQUIPMENT. PLEASE KEEP THIS MANUAL FOR FUTURE REFERENCE. IMPROPER ASSEMBLY, SET UP, USE OR MAINTENANCE MAY VOID THE WARRANTY.



**EMAIL:** [INFO@INDOORCYCLING.COM](mailto:INFO@INDOORCYCLING.COM)  
**WEBSITE:** [WWW.INDOORCYCLING.COM](http://WWW.INDOORCYCLING.COM)

© 2014 Indoorcycling Group

Manufactured by: Indoorcycling Group\* GmbH  
Happurger Str. 86 90482 Nuremberg Germany