



Installation | User's Guide

LIFEGUARD 
SMARTDOCK[®]

For the SmartDock Gen2 system.

Patent Pending

Table of Contents

| | Page |
|--|------|
| General Information..... | 3 |
| Warnings and Cautions..... | 4 |
| Tools | 6 |
| SmartDock Parts | 6 |
| Initial Set-Up and Adjustment..... | 7 |
| Select Valve Retaining Tab | 8 |
| Install the Valve Retaining Tab | 9 |
| Raise SmartDock “Head” | 10 |
| Adjust “Wings” | 10 |
| Open the SmartDock..... | 11 |
| Insert Cylinder into SmartDock..... | 11 |
| Adjust Head Height | 12 |
| Final “Wings” Adjustment..... | 12 |
| Adjust and Tighten Valve Retaining Tab | 13 |
| Installing the SmartDock into the Seat..... | 14 |
| Use | 14 |
| Normal Usage Adjustment..... | 15 |
| Maintenance..... | 16 |
| Air Pack | 16 |

General Information

The SmartDock (Generation 2) air pack holder is a device that stages air packs in SCBA seats and is designed to retain the air pack in the event of a sudden deceleration.

The NFPA 1901 committee wants to ensure that SCBA bottles stored in the fire apparatus cab do not become projectiles during a crash. For this reason, the standard states that “the bracket holding device and its mounting shall retain the SCBA unit when subjected to a 9-G force.”

With traditional SCBA brackets, there are two things that must happen for the bottles to remain in place:

1. *The firefighter must place the bottle in the bracket and latch it in place.*
2. *The bracket must be strong enough to hold the bottle.*

The first item is the responsibility of the firefighter, and the second is the responsibility of the bracket provider.

The unique feature of the SmartDock hands-free SCBA holder is that it removes the need for the firefighter to perform any extra latching, buckling or strapping action when placing the bottle in the bracket.

Once installed per these instructions, the SmartDock is designed to meet NFPA 1901 requirements without any extra action by the firefighter, other than properly placing the bottle into the bracket.

The SmartDock uses inertia to keep the claws locked during deceleration. This inertial action ensures that the SmartDock system will hold an SCBA bottle during an impact caused by a crash.

Short of bolting the SCBA bottle to the structure of the cab, there is no way to guarantee the bottle will always be retained if the crash is sufficiently severe. The SmartDock bracket has been tested to exceed NFPA 1901 requirements during a frontal crash. This capability provides the optimum combination of convenience and strength, keeping the bottle retained beyond NFPA requirements and eliminating the risk that a firefighter will forget to engage the strap or the latch. For these reasons, we believe SmartDock provides the safest solution to in-cab SCBA storage available today.

⚠ WARNING**Failure to follow these warnings may result in serious injury or death.**

- Read all SmartDock Installation / User's Guide instructions before installing or using SmartDock.
- SmartDock is to be used for SCBA bottle and air pack storage only.
- Keep air pack harness loose when seated and belted. Bottle may not stay in holder during a crash if the user has the harness strapped on tightly. Per NFPA Regulation 1901, SCBA straps should be worn loosely.
- Ensure proper fit of SCBA in SmartDock claws.
- Ride only with SCBA installed in seat.
- Always wear seat belt – SCBA harness is not designed to hold firefighter in a crash.
- Use only with SCBA bottle and air pack weighing less than 35 lbs.
- Verify that the valve retainer brand ID matches the brand of the air pack you are using. If they do not match, the pack may not be retained during a crash.

• Adjust to fit before use

The SmartDock SCBA holder must be adjusted to fit the SCBA bottle to be stored in it. Do not store any air pack or bottle that does not meet the fit criteria. Storing any SCBA bottle and pack that does not fit properly is dangerous as it may not be retained during a crash.

• Claw Grip/Adjustment

The claws grip the bottle during a crash. The claw assembly must be adjusted vertically so it grips the bottle where air pack harnesses, hoses or other obstructions do not prevent the claws from closing properly. Do not store any bottle and air pack if the claws cannot be adjusted to be clear of obstructions.

Never modify the SmartDock to adjust the claws outside of the range provided.

- Air packs must be maintained in good condition and kept clean. Storing dirty, oily or damaged bottles may affect the ability of the SmartDock to hold the bottle. The SmartDock must be kept clean. Make sure the claws are kept clean and oil free.
- Without inserting an air pack, check the claws periodically to make sure they freely open and snap shut. This can be done by pulling the claws open by hand and then shutting them again.
- Use only furnished grade 5 fasteners to attach the SmartDock unit to seat brackets.

Valve Retainer

During a crash, the air pack is held in place by the claws and valve retainer. The valve retainer is the receptacle into which the valve must fit. The shape of the bottle valve is not the same for all air pack manufacturers, therefore the proper valve retainer must be used. To facilitate matching of the correct valve retainer to SCBA valve, the valve retainers have been marked for easy identification. For ease of operation and safety, the correct valve retainer must be properly matched to the SCBA valve being used. **Verify that the valve retainer brand ID matches the brand of the air pack you are using. If they do not match, the pack may not be retained during a crash.**

⚠ WARNING

Failure to install, maintain and use SmartDock in accordance with the instructions in this Installation / User's Guide and those provided by the Vehicle Manufacturer can result in serious injury or death.

Standards Reference:

NFPA-1901, 2003 Edition, Standard for Automotive Fire Apparatus

NFPA-1852, 2002 Edition, Standard on Selection, Care, and Maintenance of Open-Circuit Self-Contained Breathing Apparatus (SCBA)

Users must read and follow these instructions. They are written to comply with NFPA guidelines.

Tool List

- 1/4 and 3/16 hex sockets and hex keys (Allen wrench)
- 5/16 socket
- 9/16 socket
- 1/2 inch socket
- Torque wrench capable of reading from 8 to 30 ft*lbs (100 to 360 in*lbs)

SmartDock Parts

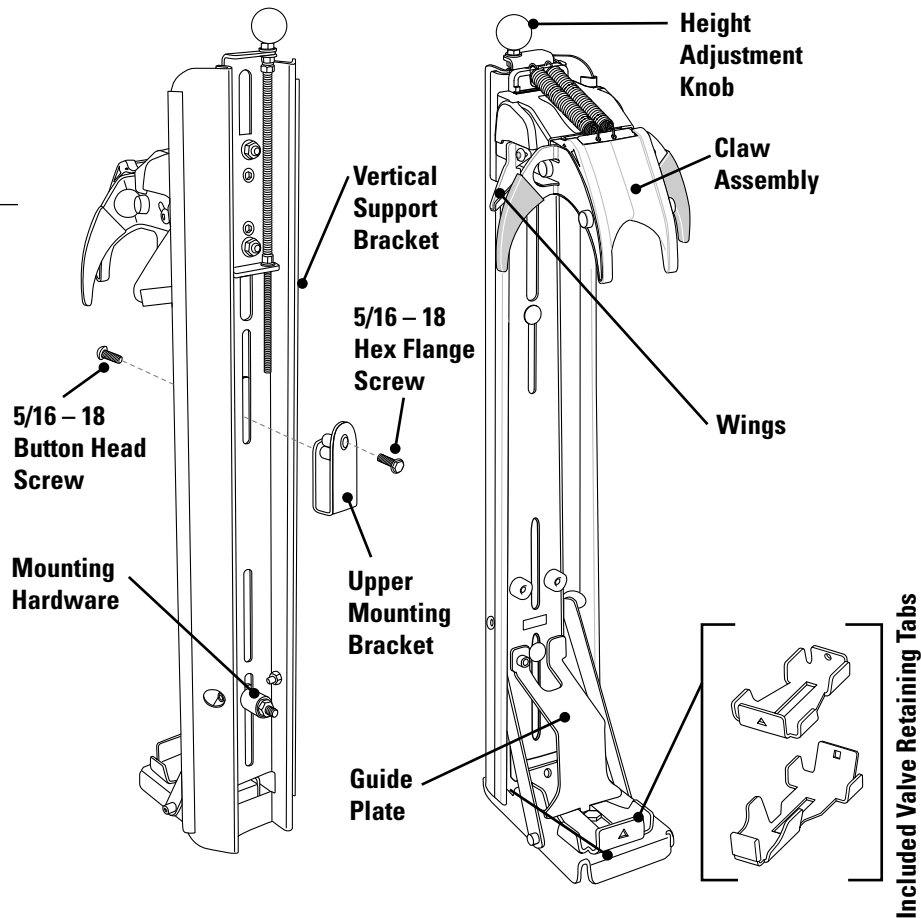

Mounting Hardware and Loose Parts

Verify parts list.

- (1) 5/16 - 18 bolt (pre-installed)
- (1) spacer (pre-installed)
- (1) 5/16 - 18 locking nut
- (2) additional valve retaining tabs
- (2) 5/16 - 18 button head screws
- (1) upper mounting bracket

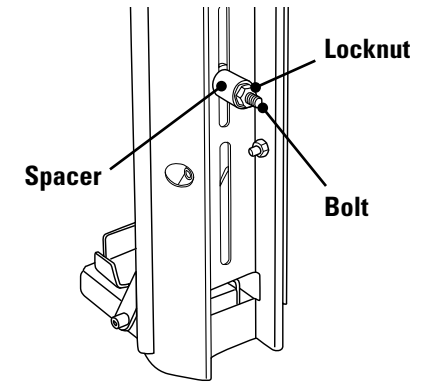

SmartDock Initial Set-Up and Adjustment

Initial set-up and adjustments should be performed with the SmartDock removed from the SCBA seat, as access to some adjustments will be difficult or impossible.

Remove the SmartDock from the seat by removing the mounting nut and bolt from the backside of the seat.

Make sure to note the mounting position for easy re-installation.

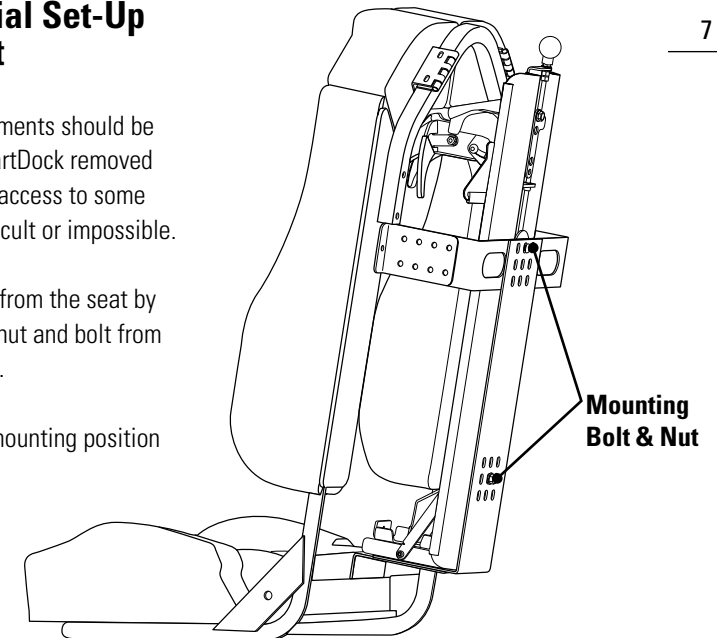

Note: Steps 1 - 2 should be followed before the SmartDock assembly is installed in the seat.

Step 1. Select Valve Retaining Tab

Each SmartDock assembly ships with two reversible valve retaining tabs. These three tabs give you four options, accommodating virtually every SCBA manufacturer on the market today.

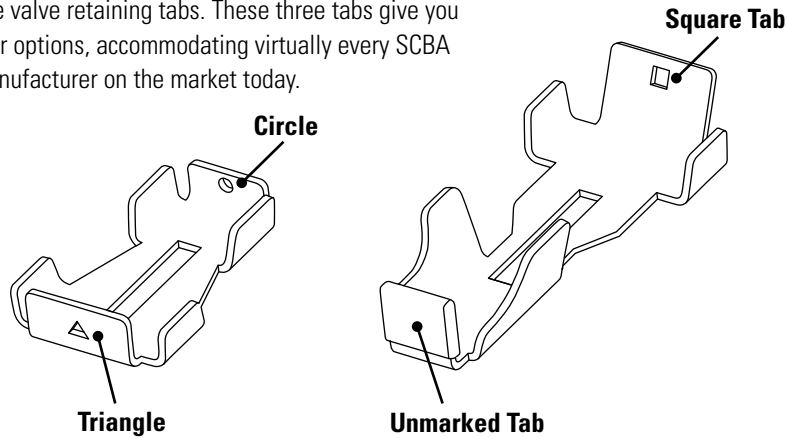

The SmartDock assembly has been pre-configured to accommodate the **Scott SCBA valve** as shown (also accommodates Draeger, Survivair and Sperian). If this is the valve used in the seat where the SmartDock system is to be installed, refer to step 3 to verify that the cylinder fits properly. If a different SCBA valve will be used, the following instructions explain how to configure the SmartDock for each SCBA valve brand.

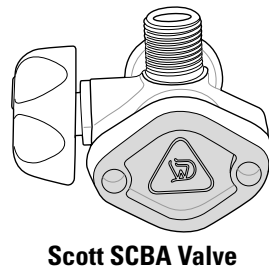

⚠ WARNING
If the wrong valve retainer tab is used, the air pack may not be retained during a collision and could result in serious injury or death.

Valve Retainer Identification Mark

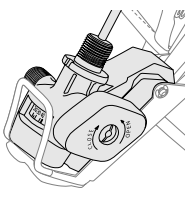
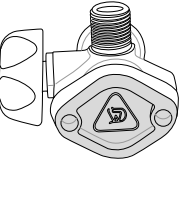
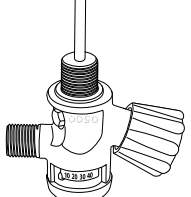
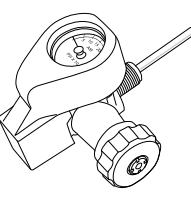
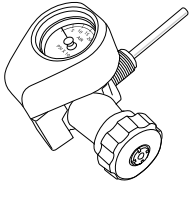
| ■ Square | ▲ Triangle | ● Circle | Unmarked |
|--|---|---|---|
|  <p>Interspiro</p> |  <p>Scott Draeger Survivair Sperian</p> |  <p>ISI</p> |  <p>MSA tall</p> |
| | | |  <p>MSA Short</p> |

Step 2. Install the Valve Retaining Tab

- Using the table above, identify the SCBA brand and the corresponding valve retainer tab that you use.
- Using the appropriate valve retaining tab, mount it to the bottom plate using the 3/8-16 hex bolt and washer as shown. Slide the tab as far forward as possible. This position will work well with most SCBA systems. Torque the hex bolt to 280 in*lbs (23 ft*lbs). The smaller hex head bolt on the bottom plate works as a key in the slot to provide fore and aft alignment of the valve-retaining tab to ensure proper fit.
- Reinstall the guide plate by aligning the tab into the slot in the bottom plate. Install the 1/4-20 socket head cap screw as shown and torque to 100 in*lbs (8 ft*lbs). If a tighter fit is desired, repeat the instructions in (b) and adjust the tab reward by small amounts until the desired fit is achieved.

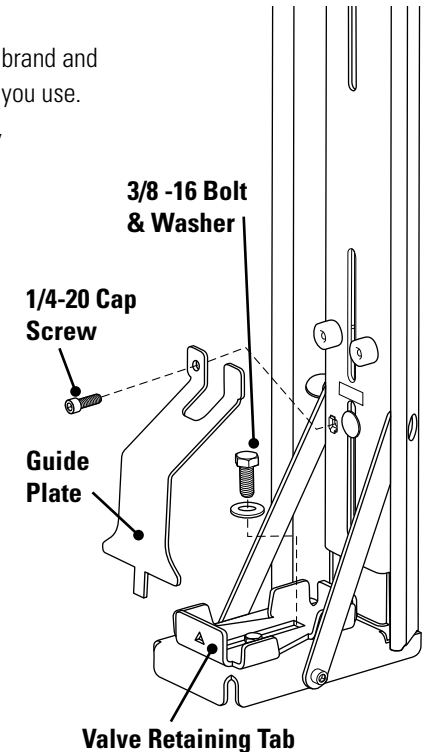

Step 3. Raise SmartDock "Head"

Before installing the cylinder into the SmartDock for the first time, verify that the SmartDock head is at least as high or slightly higher than the length of the SCBA pack as measured from the bottom of the valve to the rounded end of the cylinder. Use caution when working with the SmartDock head to avoid pinch points.

Note: Turning the height adjustment knob clockwise raises the head and counter-clockwise lowers the head.

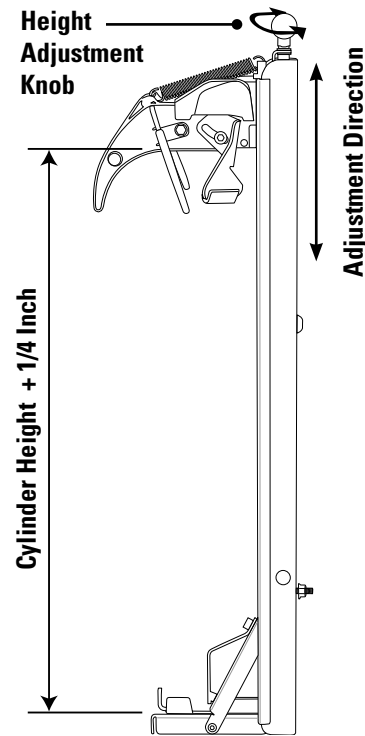

Step 4. Adjust "Wings"

Using a 1/4 hex key, loosen the socket head cap screws on both sides that hold the wing adjustment and adjust the wings to their most rearward position. It is only necessary to loosen the button head cap screws about a 1/4 turn.

Button Head Cap Screw

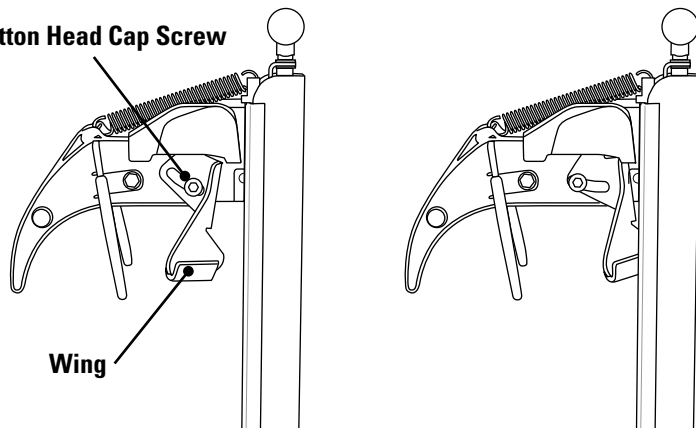

Step 5. Open the SmartDock

Grasp the yellow side of the "claw" on the SmartDock head and pull it out while rotating it up. The mechanism will be staged in its open position.

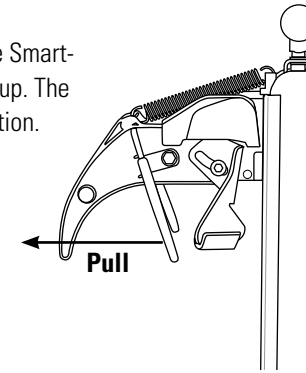

⚠ CAUTION

SmartDock claw assembly uses high spring force to open and close. Use caution and avoid potential pinch points when operating claw assembly manually.

Step 6. Insert Cylinder into SmartDock

You are now ready to insert the SCBA cylinder into the SmartDock and complete the initial adjustment procedure.

- a. Place SCBA cylinder valve into SmartDock valve retaining tab.
- b. Push the top of the SCBA cylinder into the open SmartDock head which will automatically close once inserted far enough.

Note: Insertion will become easier after final adjustments have been made.

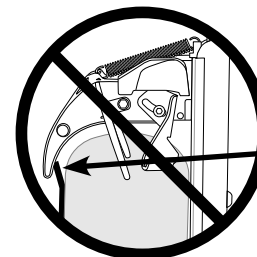
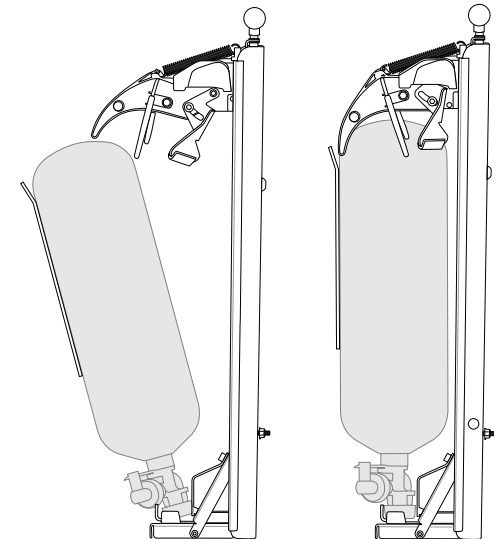

Note: No part of the SCBA pack (frame, hoses, etc.) should be inside the claw.

Step 7. Adjust Head Height

During normal operation, the SmartDock head should just touch the top of the SCBA air cylinder. Adjust the head height by turning the height adjustment knob counterclockwise to lower the head until the gap between the top of the SCBA air cylinder and the bottom of the SmartDock head is eliminated. The top of the SCBA air cylinder should be just touching the bottom of the SmartDock head.

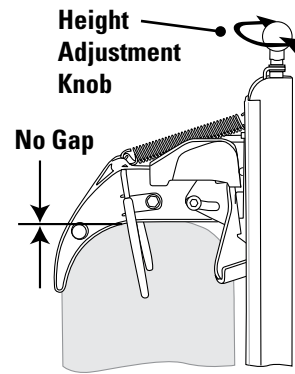
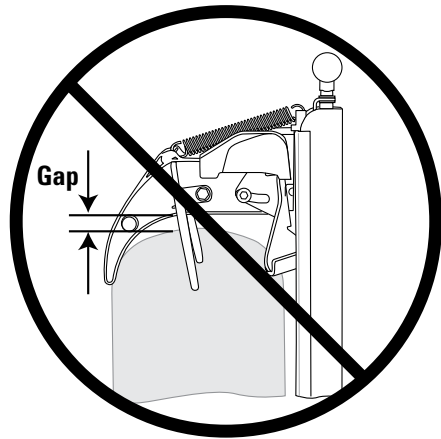

12

Step 8. Final "Wings" Adjustment

The SmartDock "wings" hold the SCBA air cylinder in the proper orientation and help close the head when inserting the SCBA air cylinder into the SmartDock.

Holding the SCBA air cylinder forward against the two front claws, loosen the two wing adjusting screws, swing the wings forward until they touch the SCBA air cylinder, and then tighten the wing adjusting screws to 22 ft*lbs of torque.

The wings are **not intended to be tight** against the SCBA air cylinder, and there will be a small amount of play between the SCBA air cylinder and the wings.

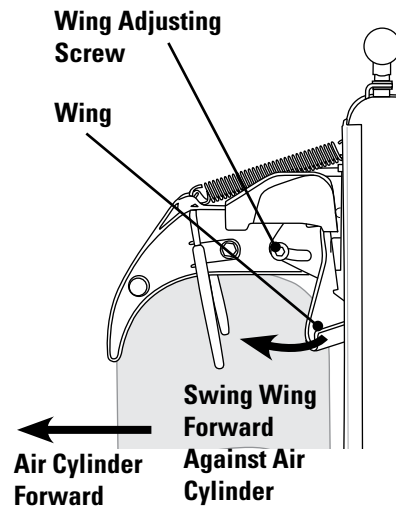

Installing the SmartDock Into the Seat

The SmartDock ships with pre-installed mounting bolts and spacers for seat installation. The SmartDock uses the existing SCBA holder mounting brackets that are supplied with SCBA compatible seats.

1. Place the SmartDock in the seat and check the position of the pre-installed mounting bolts and spacers. If the pre-installed bolts do not line up with the existing mounting holes, the upper mount may be loosened and shifted in the upper slot, and the lower bolt and spacer can be relocated into either of the lower mounting slots.
2. Align the mounting bolts with the desired holes in the seat and secure them to the seat using the supplied 5/16-18 locking nut for the lower mount and the 5/16-18 button head cap screw for the upper mount. Torque all fasteners to 20 ft*lbs.

SmartDock can be mounted directly to the back wall. This will require a wall mount kit which can be purchased from Pierce Customer Service.

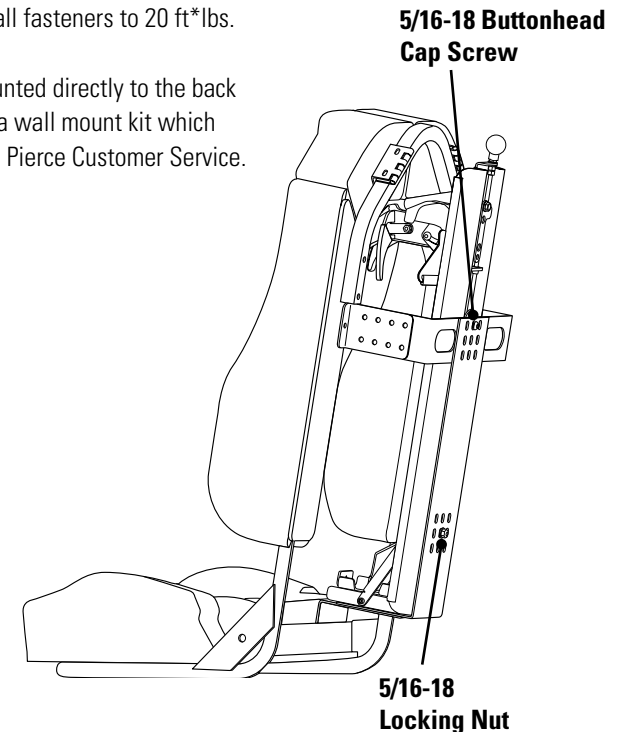

13

SmartDock Use

Use the following steps to safely ride in the seat when traveling to a fire:

1. Don bunker gear prior to entering the cab.
2. Enter cab safely using a three-points-of-contact method.
3. Don air pack that is stored in the seat back.
4. Leave the SCBA pack harness loose until you exit the seat.
5. Buckle seat belt.
6. Indicate to driver that you are buckled safely in the seat.
7. Ride safely to the fire scene.
8. Do not unbuckle seat belt until the vehicle has come to a stop, the parking brake is engaged and the officer indicates it is safe to exit the cab.
9. Tighten pack harness straps and exit the seat by bending forward to allow release from the SmartDock.
10. Ride only with SCBA installed in seat.

Normal Usage Adjustment

During normal use, the SmartDock head must be raised or lowered to properly fit the SCBA and ensure the safe functioning of the system. This is due to small differences in SCBA air cylinder length that can affect the fit of individual SCBA air cylinders and the SmartDock.

- If the head is too high, the SCBA air cylinder will seem loose in the SmartDock, as the head will not be touching the top of the SCBA air cylinder. If severely out of adjustment, the claw may seem like it stays open too long, and it may be difficult to keep the pack, hoses and straps out during the insertion of the SCBA.
- If the head is too low, the SCBA air cylinder will be difficult to insert and the SmartDock head will require some force to completely close instead of drawing the air cylinder in automatically. In some severe cases, the head may not close at all.

To lower the SmartDock head, turn the height adjustment knob **counterclockwise** as if you were trying to "unscrew" the knob.

To raise the SmartDock head, turn the height adjustment knob **clockwise** as if you were trying to tighten the knob.

When tilting the cab for maintenance, it is recommended to remove SCBA packs from the SmartDock.

WARNING

If you are unable to determine what type or size of valve you have, do not use SmartDock. Using an unapproved tank and/or valve could result in the tank being released in a crash. Serious injury or death could result. Contact 317.867.8383 if you have questions regarding fit and use of SmartDock.

Maintenance

The SmartDock needs to be kept clean. Make sure the claws are kept clean and oil free. Without inserting an air pack, check the claws periodically to make sure they freely open and snap shut. This can be done by pulling the claws open by hand and then shutting them again.

Air packs must be maintained in good condition and kept clean. Storing dirty, oily or damaged bottles may affect the ability of the SmartDock to hold the bottle. For proper maintenance of air packs, refer to: *NFPA 1852 Standard on Selection, Care and Maintenance of Open-Circuit Self-Contained Breathing Apparatus (SCBA)*.

For additional information, visit

lifeguardtechnologies.com/firerescue/smartdock/index.htm.



A Brand of IMMI

18881 U.S. 31 North | Westfield, IN 46074-0408 | 866.765.5835
lifeguardtechnologies.com