

HANDHELD ECG MONITOR

INSTRUCTION

MANUAL

Edition: V1.0B1

Copyright

Our company owns all rights of this unpublished work and intends to maintain it as a confidential work. We may also seek to maintain this work as an unpublished copyright. This publication is to be used solely for the purpose of reference or operation of our software system. No part of this work can be disseminated for other purposes.

In the event of inadvertent or deliberate publication, we intend to enforce its right to this work under copyright laws as a published work. Those having access to this work may not copy, use, or disclose the information in this work unless expressly authorized by our company.

All information contained in this publication is believed to be correct. We shall not be liable for errors contained herein nor for incidental or consequential damages in connection with the furnishing, performance, or use of this material. The information this publication refers to is protected by copyrights or patents and does not convey any license under the patent rights of our company, nor the rights of others. We do not assume any liability arising out of any infringements of patents or other rights of third parties.

Contents of this manual are subject to changes without prior notice.

 This item is compliant with Medical Device Directive 93/94/EEC of 14 June 1993, a directive of the European Economic Community.

All rights reserved.

Issue date: 9/September 2009

Notes on Safety

This device is intended to monitor the ECG waveform, not for medical diagnosis. Never use the device in critical situations!

- Self-diagnosis and treatment is dangerous.

The measurement results are reference for analyzing the cardiac rhythm of patients by doctors only, and should never be used as a basis for starting or modifying treatment without independent confirmation by medical examination. Do NOT make diagnosis by yourself according to the measurement and analysis results; always consult your doctor if abnormal information is presented frequently.

- The values displayed by the device are the values at the time of measurement.

Medical conditions can change suddenly. If you notice any change in your condition, consult your doctor, regardless of the measurement results.

- DO NOT Use the device for treatment, we will not responsible for the suddenness happened during a measurement.

Warnings!

✧ Do not use with a cardiac pacemaker.

✧ Do not use with a defibrillator.

✧ Do not use in the presence of flammable anesthetics, drugs or pressurized oxygen (such as in a hyperbaric chamber, ultraviolet sterilizer or oxygen tent).

✧ Do not attempt self-diagnosis of the measurement results and analysis. Always consult your doctor.

- Self-diagnosis may lead to deterioration in your condition.

✧ Do not use on patients with significant resting tremors.

✧ Do not use on people with sensitive skin or allergies.

- This may result in exanthema, skin irritation, or eczema.

✧ Keep out of reach of small children and people who cannot express their consent.

✧ Do not use for any purpose other than obtaining an electrocardiograph.

✧ Do not expose the device to strong shocks or vibrations, or drop or step on the device.

✧ Do not use batteries of a type other than that specified in this manual.

✧ Do not apply over clothing.

- ✧ Do not take measurements when there are drops of water on your skin, such as from sweat or after bathing.
- ✧ Do not take measurements where the device will be exposed to strong electromagnetic forces.

Caution!

- ✧ Do not expose the device to static electricity. Always disperse any static electricity from your body before handling the device.
- ✧ Do not take measurements in a moving vehicle.
- ✧ Do not use a cellular phone near the device.
- ✧ Do not disassemble, repair, or modify the device.
- ✧ Do not insert batteries with their polarities reversed.
- ✧ The chest electrode will be impeded by excessive body hair, regularly remove hair at the electrode contact point.

General

- ✧ Avoid extremes in temperature and humidity. Do not use this device in locations subject to high or low temperatures or humidity.
Use at a temperature within 5°C to 40 °C and below 80% RH.
- ✧ Do not sterilize this device in an autoclave or gas sterilizer (EOG, formaldehyde, high density ozone etc.)
- ✧ Do not wash this device with water.
- ✧ Do not store the device in the following ambient conditions.
 - Locations exposed to direct sunlight.
 - Locations subject to high temperatures and high humidity.
 - Wet or damp locations where water may get on the device.
 - Dusty locations.
 - Near fires or open flames.
 - Locations exposed to strong vibration.
 - Locations exposed to strong electromagnetic fields.
- ✧ Dispose of the device and its accessory according to applicable local regulations.

Contents

| | |
|-----------------------------------------------------------------------|---------------|
| 1. General Description | - 6 - |
| 2. Inserting and Replacing Batteries | - 9 - |
| 3. Setting the ID, Date and Time | - 11 - |
| 4. Taking a Measurement | - 12 - |
| 5. Measurement Results | - 20 - |
| 6. Displaying ECG | - 21 - |
| 7. System Settings | - 23 - |
| 8. Data Management..... | - 24 - |
| 9. Version..... | - 25 - |
| 10. Trouble Shooting..... | - 25 - |
| 11. Key Symbols..... | - 26 - |
| 12. Technical Data | - 26 - |
| 13. Maintenance and Storage | - 31 - |
| 14. General information about the Heart and ECG Measurements . | - 32 - |

1. General Description

1.1 Know Your Device

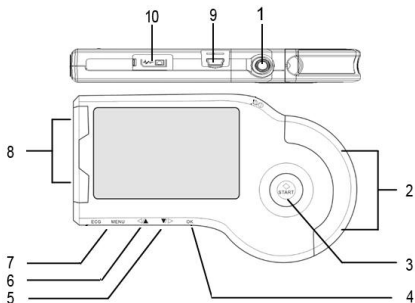

Picture 1

Description of Picture 1:

- ① **POWER** button: Power on or off the device.
- ② **Metal Electrodes** : Hold these two with right index finger when taking a measurement.
- ③ **START** button: The shortcut key for ECG measurement.
- ④ **OK** button: Press this button to confirm the selection or set date and time when in the Date and Time Setting Mode.
- ⑤ **▼/▶** Button: Press this button to move the cursor to your desired menu or change the number, or move the wave form to the left.
- ⑥ **◀/▲** Button: Press this button to move the cursor to your desired menu or change the number, or move the wave form to the right.
- ⑦ **MENU** button: Return to the previous menu by pressing this button.
- ⑧ **Metal Electrodes**: Place this against the center of left palm or chest when taking a measurement.
- ⑨ **ECG cable socket**: When taking a measurement by ECG cable, connect the ECG cable with this port.
- ⑩ **USB interface**: Transmit data to the PC through this interface.

1.2 Product Features

- ✧ Small, portable and easy to use.
- ✧ completely cable free
- ✧ Choice of two measuring modes
- ✧ USB data transmission
- ✧ Fast measurement in just 30 seconds
- ✧ 200 records of ECG Strips, each record with 30-second ECG waveform and analysis result.
- ✧ Measurement of one channel ECG anytime, anywhere you like
- ✧ Display of ECG waveform, heart rate, analysis results and battery status on the backlit LCD screen.
- ✧ Auto power-off while no key is pressed in period of time that can be set.
- ✧ Auto-evaluation based on detected heart data.
- ✧ Two AAA batteries can support at least 400 measurements.
- ✧ Data Review freely.

1.3 Intended Use

The MD100 ECG monitor is a handheld device indicated for use in non-invasively detect and displaying ECG waveform for self testing of adult in daily life; otherwise it also can provide the doctor with relevant data on the heart condition of the patient in hospital. It is available to manually record transient cardiac events immediately at any time, suitable for patient and professional use, helpful in determining cardiac aetiology of symptomatic events. This ECG monitor allows the consumer to record their ECG data into the device memory and displays the ECG data to the healthcare professional during office visits.

NOTE:

1. The measured result by the product is just for reference to doctor but not for diagnosis evidence.
2. The product is not suitable to monitor patient continuously.

1.4 Display

The screen is used to display the ECG waveform, analysis results, all kinds of parameters, such as time & date, battery status etc., and the status of data storage in memory.



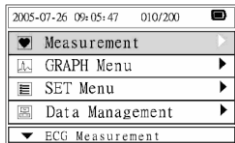

Menus

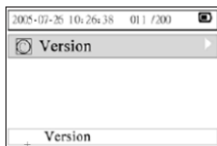

Picture 2



Picture 3

- “ **-Measurement**”: Enter this menu to select the measurement mode and take a measurement.
- “ **-GRAPH Menu**”: Enter this menu to review, delete, and lock the detected ECG waveform and analysis result.
- “ **-SET Menu**”: Enter this menu to set the Date & Time, Brightness, Beeper, Automatic Power-off, ID Setup and Wave Scale.
- “ **-Data Management**”: Enter this menu for selecting to erase the data.
- “ **-Version**”: Enter this menu to look over the monitor's information.

2. Inserting and Replacing Batteries

- 2.1 Open the battery cover on the back panel of the device.
- 2.2 Insert two AAA batteries lightly as indication of the polarity sign (refer to Picture 4) .

Note: Make sure the polarity of the batteries is correct.

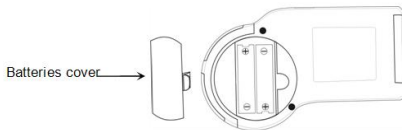

Picture 4

- 2.3 Close the battery cover.



Make sure that the polarity of the batteries is correct. Otherwise the device cannot operate normally.

Battery life and replacement

When the “Battery power is low please change with new ones timely” message appears, replace batteries with new ones.

- ✧ Always turn off the device before replacing the batteries.
- ✧ Dispose of the used batteries according to the applicable local regulations.

Battery life

- ✧ Two new AAA batteries will last for approximate 400 measurements. (If measurements are performed once a day at room temperature (22°C).)
- ✧ The batteries enclosed in the package are used for demonstration purpose. It is possible that these batteries will not last for 400 measurements.
- ✧ The battery life can be confirmed in the upper right of the LCD display.



Full power



low power



no power

When the sign “” appears, it means the battery power is not sufficient, and the device will show information as picture 5. We suggest users replace the batteries with new ones.

Battery power is low please change with new ones timely.

Picture 5 Low power



Warnings!

If battery fluid should get in your eyes, immediately rinse with plenty of clean water. Consult a doctor immediately.

Caution!

- ✧ Do not use batteries not specified for this device. Do not insert the batteries with the polarities in the wrong direction.
- ✧ Do not dispose of batteries in fire.

- ✧ If battery fluid should get on your skin or clothing, immediately rinse with plenty of clean water.
- ✧ Remove batteries from this device when you are not going to use it for a long period of time (approximately three months or more).
- ✧ Do not use batteries of a different type together.
- ✧ Do not use new and used batteries together.

3. Setting the ID, Date and Time

Always set the ID number, date and time before using the device for the first time.

Set the ID number for different users. Check the date and time are correct before using the device, reset them if necessary. The ID number, date and time are important indicators when a measurement is taken.

3.1 Date and time setting

Note: The date and time information will be displayed on the screen in format of "Year/Month/Date"; "Hour/Minute/Second".

1. Press the  Power button for 3 seconds to turn on the device.



Picture 6

2. Select the "SET menu" item, as shown in Picture 7. And then press the "OK" button to enter.

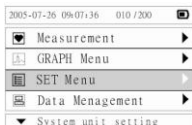

Picture 7

3. Select the "Date and Time" item, as shown in Picture 8, then press the "OK" button.

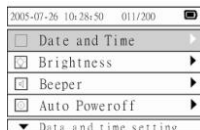

Picture 8

- Press the “OK” button to select the item, and press $\blacktriangledown/\triangleright$ or $\triangleleft/\blacktriangle$ button to set the “Date and Time” values and then press the “MENU” button to confirm your settings.

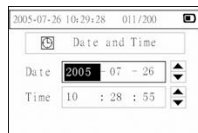

Picture 9

3.2 ID setting

NOTE:

ALWAYS set different ID numbers for every user before taking a measurement.

- Press the $\blacktriangledown/\triangleright$ “Down or right” button to select the “SET menu”. And then press the “OK” button to enter.

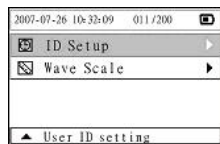

Picture 10

- Press the $\blacktriangledown/\triangleright$ “Down or right” button to select the “ID Set up” menu, then press the “OK” button to enter into the ID Set up screen. Then press the $\triangleleft/\blacktriangle$ or $\blacktriangledown/\triangleright$ button to set the ID number. The ID number range is from 1 to 255.

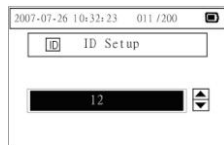

Picture11

4. Taking a Measurement

The methods of measurement include palm measurement, chest measurement and cable measurement. The measurement modes include Easy Mode and Continuous Mode.

Important Notes on Taking a Measurement

In order to obtain a good ECG reading, it is important that measurements are taken correctly. Please read the instructions carefully before taking a measurement for the first time, and follow the instructions each time you take a measurement.

- ◇ Make sure that the electrodes are directly touching your skin.
- ◇ If your hands or skin are dry, wipe them with a damp towel so that they are slightly moist.
- ◇ If the electrodes are dirty, wipe any dirt off with a soft cloth moistened with disinfectant alcohol or a cotton swab.
 - Take care not to use too much disinfectant alcohol when cleaning the electrodes.
 - Do not wipe or get disinfectant alcohol on parts other than the electrodes.
- ◇ Do not move during measurement.
 - Movement, including talking, coughing, or sneezing, during measurement can affect the measurement results.
- ◇ If the position of your finger or arm is inappropriate during measurement, the results may be inaccurate, so be sure to check their position before taking a measurement.
- ◇ After taking a measurement, disinfect the electrodes by wiping them with a soft cloth or cotton swab moistened with disinfectant alcohol. If you do not disinfect the electrodes there is a risk of skin disease.

Note:

If the contact of the electrodes become loose, or the conditions change during measurement, the measurement may not be correct.

4.1 Press the  Power button for about 3 seconds to turn on the device.

Enter the menu interface as shown in Picture 12 and select the option “Measurement” item, then the interface switches to the one as shown in Picture 13. Measurement Modes include Easy Mode and Continuous Mode. Choose “Easy Mode” item, then click “OK” button. The interface will appear as shown in Picture 14. When the count down from six to zero, the measurement starts.

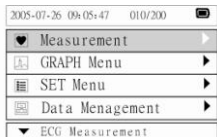

Picture 12

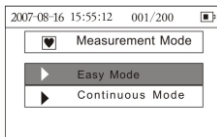

Picture 13

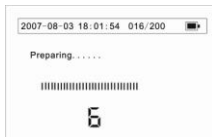

Picture 14

4.2 Make sure that you are in a relaxed position. Then press the “START” button to start a measurement, and the measuring mode depends on your selection in “Measurement” menu.

Note: The ideal posture is one where you are seated comfortably with your back straight. You can also take a measurement while you are standing or while lying down. And be sure to keep still and do not move until the measurement is complete.

4.3 Palm Measurement

Make sure hold the “2” metal electrodes of the device with right index finger firmly., and place the “9” electrodes against the center of the left palm. (Refer to Picture 15)

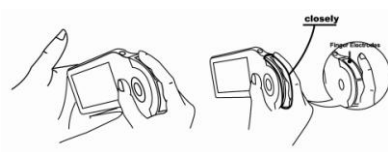

Picture 15

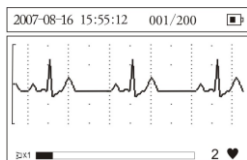

Picture 16

Description of Picture 16:

“2007-08-16”: The current date.

“15:55:12”: The current time.

“001/200”: It indicates one measurement has been saved in the monitor and the monitor can store up to 200 records.

 : Indication of the power of battery.

 : ECG amplitude ruler.

 : The examined ECG waveform.

x1: ECG waveform scale. You can select the displaying scale (X 0.5, X 1, X 1.5 or X 2) in the "SET Menu".

: Sign of speaker status.

: The status bar of measurement progress.



2: Indication of measurement time.

: The sign of heartbeat, it twinkles synchronously with the heart beat.

It takes about 30 seconds to complete the measurement. During the measurement, the device will beep synchronously along with the heart beat, the screen displays the ECG waveform and progress bar at the bottom of the screen indicates measurement progress.

During measurement, the screen displays the ECG waveform, and the progress bar at the bottom of the screen displays measurement progress.

Notes:

- ✧ During measurement the device will only respond to the "MENU" or "OK" button to discontinue the measurement.
- ✧ If the contact between the electrodes and skin becomes loose, or the conditions change during measurement, the measurement may be incorrect.
- ✧ When the electrodes are contacted not well during the measurement, the device will remind you with  icon at the bottom of the screen next to the  icon.
- ✧ Keep still and do not move until the measurement is complete.

Wrong Operation Methods:

- A. Both hands move at will
- B. Both bands contact with the electrode loose during the measurement.
- C. No palm/finger touches the electrode.

A measurement result message is displayed when the measurement has been completed (refer to Picture 17 &18 for detail).



Picture 17

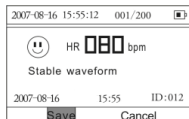

Picture 18

Description of Picture 18:

“**2007-08-16**”: The current date

“**15:55:12**”: The current time

“**001/200**”: It indicates one measurement has been saved in the monitor and the monitor can store up to 200 records.

: Indication of the power of battery.

“**HR 080 bpm**”: The heart rate is 80 beats per minute.

“**2007-08-16**”: The record storage date

“**15:55**”: The record storage time in term

“**ID: 021**”: The ID number

The results will be stored automatically within 3 seconds. The system can memorize 200 pieces of records at most. When the records are full, the icon  will appear on the upper right of the LCD screen (shown as the Picture 19 & Picture 20).

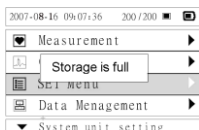

Picture 19

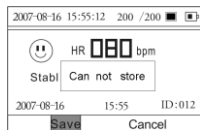

Picture 20

After you finish saving the 200th measurement result, the system will remind you that the storage is full (shown as Picture 19), after that, If you want to store another record, the system will remind you that the record can not be stored (shown as Picture 20), until the user deleted the unnecessary records.

Caution!

DO NOT use result for direct diagnostic or analytical decision, but use it for reference **ONLY**.

Press the ① button for four seconds to turn off the device.

Note: If you forget to turn the device off, it will automatically shut down within one minute.

Users can set the auto power off time limit (1 minutes, 2 minutes...10 minutes) in "System Settings".

4.4 Chest measurement

If palm measurement is not ideal, please adopt chest measurement.

4.4.1 Measurement for Male:

Hold the device with the right hand; make sure that the index finger makes contact with the "2" metal electrodes sufficiently. Place the "9" electrodes against left chest on bare skin about 5cm below your left nipple. (Refer to Picture 20)



Picture 21

Note: If you have problems in applying the device so that the "9" metal electrodes are flat against your chest, please ask your doctor for advice.

4.4.2 Measurement for Female

Locate the ECG monitor at the lower end of breastbone and move horizontally to the middle of the left part of the chest. If necessary, gently lift the breast and place the "9" electrodes under the left breast. Unless the electrodes come in contact with the brassiere, it is NOT necessary to remove it; if you are unsure **please consult your doctor**.

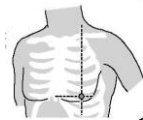

Picture 22

To obtain the high quality ECG, users can adopt the cable measurement.

Note: The small open circle indicates the proper position of electrodes, as shown in Picture 22.

Improper Operation Methods:

- The touching point of the “9” electrodes do NOT contact left chest.
- The handhold gesture is NOT correct.
- The “9” electrodes do not contact fully the skin. (e.g. the monitor impeded by clothes while taking a measurement)

Notes:

- ◇ Make sure that you are relaxed and that your chest is free of tension.
- ◇ Press the electrodes close against your bare chest. Do not place the electrodes on clothing as this will result in an inaccurate measurement.
- ◇ If measuring in dry circumstance, which might cause weak heart pulse signal, please wet your skin or hands with some diluted salt water or clean water. This would strengthen the heart pulse signals, and make the recording much more accurate.
- ◇ When doing chest measurement, if you have problems applying the device so that the “9” metal electrodes are flat against your chest, please ask your doctor for advice.

4.5 Cable Measurement

If palm measurement is not ideal and it is not convenient to adopt chest measurement, the cable measurement will be recommended. The first step is to place electrodes slices on the right body area as shown in pic.23(1) and then connect the cable and the unit effectively through the lead port, refer to pic.23(2).

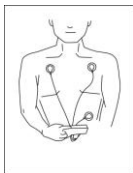

Picture 23(1)

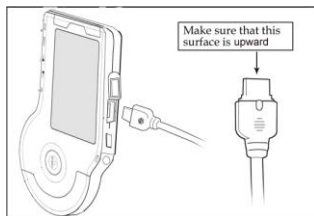

Picture 23(2)

(1) The position for placing the cable electrode is shown in Picture 23.**AHA:**

White (right arm RA) electrode — put it under the clavicle ,next to the right shoulder.

Black (left arm LA) electrode — put it under the clavicle ,next to the left shoulder.

Red (left leg LL) electrode — put it at the left of the underbelly.

IEC:

Red (right arm R) electrode — put it under the clavicle ,next to the right shoulder.

Yellow (left arm L) electrode — put it under the clavicle ,next to the left shoulder.

Green (left leg F) electrode — put it at the left of the underbelly.

Note: Be sure to place the electrode slices over measured part well before pressing the “START” button.

(2) The connection with ECG lead cable(refer to picture. 23(2))

Make sure that deeply insert the ECG cable connector with mild force.

When the measurement is failed, please check the placement of electrode slices or the connection of the unit and lead cable.

Wrong Operation Methods:

A. Connect wrong cable mount.

B. Electrodes contact wrong position of the body.

**Warnings! Very Important!**

Users are strictly prohibited to attach the lead wire electrodes on their body if the lead wire is not connected with the device. Before measurement, firstly the lead wire should be connected with the device, secondly the lead wire electrodes should be attached to your body; After measurement, firstly the lead wire electrodes should be removed from body, secondly the lead wire should be disconnected with the device.

4.6 Continuous Mode

In the “Measurement Mode” you can select the “Continuous Mode” for long term monitoring. The measurement can be last for about 6 hours with two new batteries.

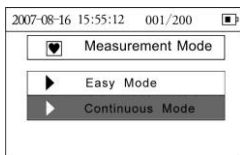

Picture 24

Note: In the continuous Mode, the measurement results can not be saved in the monitor. But the measurement results can be real-timely displayed on a computer by the data transmission software after connecting the monitor with computer by the data cable.

5. Measurement Results

In the main menu interface, press the Navigation button ↑ (up) or ↓ (down), to select “**GRAPH Menu**” item, then press the “OK” button, you will see the description of the relative record, as shown in Picture 25.

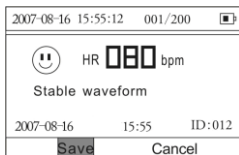

Picture 25

Caution!

- ✧ Please note that while the measurements from an ECG monitor are a useful guide for your doctor, they cannot detect all changes in heart conditions. Always consult your doctor if you notice any changes in your condition, regardless of the measurement results. Consult a doctor even if “Stable waveform” is displayed as the measurement result, if you have been diagnosed with a heart condition.
- ✧ The values displayed by the device are the values at the time of measurement. Medical conditions can change suddenly. If you notice any change in your condition, consult your doctor, regardless of the measurement results.

6. Displaying ECG

The "GRAPH Menu" is used to display, lock, or delete the list of ECG data stored.

Displaying ECG Waveform

1. If the device does NOT have stored records, it will show the following information as shown in Picture 26(1) when users enter into the "Wave Review" menu.

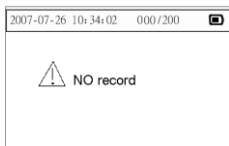

Picture 26(1)

2. Press the $\blacktriangledown/\triangleright$ button to select the "GRAPH Menu" when the main menu appears, and then press "OK" button to confirm. Refer to Picture26 (2).

| 2007-08-16 15:55:12 | | 007/200 | | |
|---------------------|------------------|---------|-------|-----|
| 1 | 2007-07-26 09:30 | 🔒 | 😊 078 | 012 |
| 2 | 2007-07-26 03:39 | 😊 | 082 | 001 |
| 3 | 2007-07-25 23:38 | 😊 | 085 | 001 |
| 4 | 2007-07-25 23:22 | 😊 | 086 | 001 |
| ▼ 1 | | | | |

Picture 26(2)

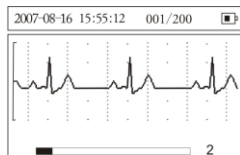

3. Press the $\blacktriangledown/\triangleright$ or $\triangleleft/\blacktriangle$ button to select the ECG data you wish to view from the ECG data list, then press the OK button to display the detailed view of the waveform. (Refer to Picture 26(3)). Press the $\blacktriangledown/\triangleright$ or $\triangleleft/\blacktriangle$ button to move forward/backward the waveforms, Press "MENU" button to exit from the current menu.



Picture 26(3)

Description of picture 26(3):

"001/200": It indicates one measurement has been saved in the monitor and the monitor can store up to 200 records.

-  : ECG amplitude ruler
-  : ECG waveform
-  : Measurement progress bar



2: The interval of the current ECG waveform.

Every piece of stored ECG data is displayed with date, time and a character representing the measured waveform.

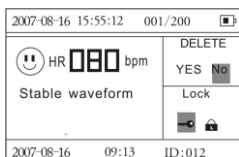

Measuring result depiction: After review the certain ECG waveform, press the "OK" button to enter in to the corresponding analysis result depiction, refers to Pic.27.









Picture 27

In the current menu press the  or  button to select YES, NO, or the KEY icon, and then press the "OK" button to reserve, delete or lock the result.

Deleting or locking the ECG data record

Deleting: Under the Pic.27 menu, press the  or  button to select the "YES" item, you will delete the current ECG records.

Locking: Press the  or  button to select the KEY icon, you will lock the current ECG records. The locked record can NOT be deleted. If you want to unlock the records, select the KEY icon again and press the "OK" button.

| | |
|-----------------------------|--------------------------------------------------------------------------------------------------------------------------------------------------------------------------------------------------|
| 2007-08-16 15:55:12 007/200 | |
| 1 | 2007-07-26 09:30   078 012 |
| 2 | 2007-07-26 03:39  082 001 |
| 3 | 2007-07-25 23:38  085 001 |
| 4 | 2007-07-25 23:22  086 001 |
| ▼ 1 | |

Picture 28



7. System Settings

Select "SET menu" in the main menu by pressing the  button, and press "OK" button to enter.

7.1 ID, Date and Time Setting

Please refer to the section "3. Setting the Date and Time".

7.2 Brightness Setting



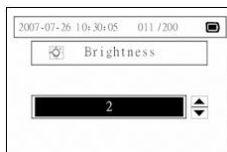

7.2.1 Press the  button to select the "Brightness", and then press the "OK" button to enter. Press the  button or  to select the backlight level from "Off" or "1, 2, 3...7" and then press "OK" button to confirm the setting. Refer to Pic.29.



Picture 29

7.2.2 Press the "OK" button to confirm, and meanwhile return to the previous menu.

7.3 Beep Setting

7.3.1 Press the  button or  to select the "Beep" menu. Then press the "OK" button to enter. Select "On" or "Off" by pressing the  button or  and press "OK" button to confirm setting. Refer to picture 30.

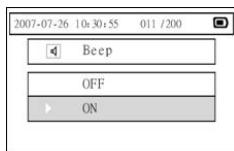

Picture 30

7.3.2 Press the "OK" button to save the settings, meanwhile return the previous screen.

7.4 Auto Power-off Setting

7.4.1 Press the $\blacktriangledown/\blacktriangleright$ button to select the "Auto Poweroff", then press the "OK" button to enter. Press the button $\blacktriangledown/\blacktriangleright$ or $\blacktriangleleft/\blacktriangleup$ button to select "off" time limit "1 Min. 2 Min.... 10 Min.", refer to Picture 31, and press "OK" button to confirm the setting.

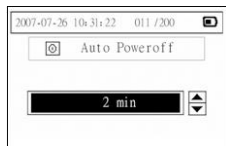

Picture 31

7.4.2 Press the "OK" button to confirm, and meanwhile return to the previous menu.

7.5 Wave Scale Setting

7.5.1 Press the $\blacktriangledown/\blacktriangleright$ button to select the "Wave Scale", then press the "OK" button to enter. Press the $\blacktriangledown/\blacktriangleright$ button or $\blacktriangleleft/\blacktriangleup$ button to select "x0.5, x1, x1.5, x2", refer to Picture 33.

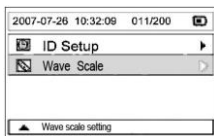

Picture 32

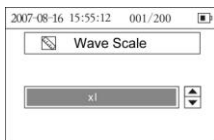

Picture 33

7.5.2 Press the "OK" button to confirm, and meanwhile return to the previous menu.

8. Data Management

In the main menu screen, press the $\blacktriangledown/\blacktriangleright$ button to select the "Data Management" item, and then press the "OK" button to enter into the sub menu. Refer to the following picture.

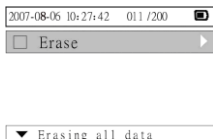

Picture 34

Press the "OK" button to confirm your selection, and meanwhile return the previous menu.

Erase the data:



Picture 35

Press the “OK” button to confirm your selection, and meanwhile return the previous menu.

9. Data Transmission

Before data transmission, make sure that the device is on and connected with a computer by the data cable attached.

The operations refer to the accompanying **Software User Manual**.

10. Version

In the main menu, press the **▼/▶** button to select the “Version”, you will get the information about monitor information.

Actually ECG arrhythmia analysis function is embedded in the device, but this function could only be initiated with a register Code. If arrhythmia analysis function is really in need, please contact the local supplier for the Register Code.











Note: The Register Code will be surcharged.

11. Trouble Shooting

| Problem | Cause | Solution |
|---------------------------------|-----------------------------------------------------------------------------------------------------------------|-----------------------------------------------------------------------------------------------------------------------------------------------|
| The device can NOT be turned on | 1 The batteries are worn out. 2.The batteries are inserted incorrectly. 3.The device might be broken out. | 1. Replace batteries with new ones. 2. Reinstall batteries with their polarities correctly. 3. Please contact the local service center. |

| | | |
|---------------------------------------------------------------|---------------------------------------------------------------------------------------------------------------------------------------------------------------------------------------------------------------------------|---------------------------------------------------------------------------------------------------------------------------------------------------------------------------------------------------------------------------------------------------------------------------------------------|
| The device is failure to measure heart rate. | <ol style="list-style-type: none"> 1. The electrodes are not made good contact with your body. 2. Move when measuring 3. Electromagnetic interference 4. The signal is too weak | <ol style="list-style-type: none"> 1 Place the electrode correctly. 2. Keep motionless and avoid moving when measuring 3. Keep away from electromagnetic interference 4. Change another method of measurement. (e.g. Chest/Cable measurement) |
| ECG waveform unstable or too much irrelevant waveforms exist. | <ol style="list-style-type: none"> 1. Your skin is dry. 2. Electrode and the body does not contact well 3. Your body is too tense. | <ol style="list-style-type: none"> 1. Cleaning skin with soap and water and moisten your skin with damp towel. 2. Check the instructions and repeat measurement. 3. Relax and repeat the measurement. |

12. Key Symbols

| Symbol | Meaning | Symbol | Meaning |
|-----------------------------------------------------------------------------------|----------------------------------------------|-----------------------------------------------------------------------------------|----------------------------------|
|  | The safe class of this device is type CF. |  | Record is locked |
|  | Warnings! Users should pay enough attention. |  | Record is full |
|  | Heart rate (Unit: BPM(beat per minute)) |  | Power button |
|  | Lead off | SN | Serial number |
|  | Low battery voltage |  | USB interface |
|  | Manufacturer's address. |  | The device is of ESD sensitivity |

13. Technical Data

Classification:

According to the type of protection against electric shock, it can be classified as internally power equipment. its application type is CF and it is the movable common

facility with no defibrillator or protection.

Operating Environment:

Operation Temperature: 5°C~40°C;

Atmosphere Pressure Range: 86kPa-106kPa;

Operation Humidity: ≤80%, no condensation ;

Operation Voltage: DC 3V (+0.3V, -0.8V); 2 AAA batteries.

Storage Environment

Storage Temperature: -20°C~55°C

Storage Humidity: ≤93%, no condensation

ECG Measurement:

Channel amount: 1 (difference input)

Measuring electrodes: Four integrative metal electrodes.

Three Measuring parts: The signals measured can be I lead (between right and left hand) and approximate II lead or III lead (between the both hands and the chest) .

Note: The signals measured by the device positioned from the right hand and left hand is lead I on a standard surface ECG. The signals measured by the device positioned from the right hand and left chest best approximates a frontal plane lead such as lead II on a standard surface ECG.

Signal bandwidth: 0.5Hz-75Hz

Sampling rate: 250Hz

Heart rate measuring range: 30bpm-240bpm

Heart rate measuring accuracy: 30~100bpm: ±2bpm; 101~240bpm: ±4bpm

Display Mode:

Display screen type: 160 × 240 dot - matrix single color LCD.

The dimension of display area: 70mm×45mm

Backlight: LCD backlight

Data Storage:

Every record stores ECG data for 30 seconds.

The device can store 200 items of ECG strips records at most.

Dimension and Weight:

Dimension: 136mm×84mm×21mm (Length x Width x Height)

Weight: 120g (Not including Two AAA batteries)

Product Accessories:

| | |
|--------------------------------|----------|
| Batteries (AAA)----- | 2 pieces |
| Pouch----- | 1 piece |
| Instruction manual----- | 1 piece |
| Quick Operation Guide----- | 1 piece |
| Warranty card----- | 1 piece |
| Data cable ----- | 1 piece |
| Data Management Software ----- | 1 piece |
| Clamp Electrode(optional)----- | 3 piece |

Notes:

- ◇ **Specifications may be changed without prior notice.**
- ◇ **Disposal of this product and used batteries should be carried out in accordance with the local regulations for the disposal of electronic products.**
- ◇ **Please use the accessories of the equipment, change another accessories may cause degrading the safety performance.**

Appendix

Guidance and manufacture's declaration- electromagnetic immunity for all EQUIPMENT and SYSTEMS

| Guidance and manufacture's declaration - electromagnetic immunity | | | |
|--------------------------------------------------------------------------------------------------------------------------------------------------------------------------------------------------|------------------------|------------------------|-----------------------------------------------------------------------------------------------------------------------------------------------|
| The Handheld ECG Monitor is intended for use in an electromagnetic environment special below. The customer or the user of the this product should assure that it is used in such an environment. | | | |
| Immunity Test | IEC 60601 Test level | Compliance Level | Electromagnetic environment guidance |
| Electrostatic Discharge (ESD) IEC610004-2 | 6kV contact 8kV air | 6kV contact 8kV air | Floors should be wood, concrete or ceramic tile. If floor are converted with Synthetic material, the relative humidity should be at least 30% |

Guidance and manufacture's declaration - electromagnetic immunity for EQUIPMENT and SYSTEMS that are not LIFE-SUPPORTING

| | | |
|---------------------------------------------------------------------------------------------------------------------------------------------------------------------------------------------------------------------------------------------------------------------------------------------------------------------------------------------------------------------------------------------------------------------------------------------------------------------------------------------------------------------------------------------------------------------------|-------------------------------|--------------------------------------------------------------------------------------------------------------------------------------------------------------------------------------------------------------------------------------------------------------------------------------------------------------------------------------------------------------------------------------------------------------------------------------------------------------------------------------------------------------------------------------------------------------------------------------------------------------------------------------------------------------------------------------|
| 61000-4-6 Radiated RF IEC 61000-4-3 | 3V/m 80Hz To 2.5 GHz | $d = \frac{3.5}{V_1} \sqrt{P} \quad 80\text{MHz to } 800\text{MHz}$ $d = \frac{3.5}{E_1} \sqrt{P} \quad 800\text{MHz to } 2.5\text{GHz}$ <p>Where P is the maximum output power rating of the transmitter in Watts (W) according to the transmitter manufacture and d is the recommended separation distance in meters (m).</p>  <p>Field strengths from fixed RF transmitters, as determined by an electromagnetic site survey, should be less than the compliance level in each frequency range.</p> <p>Interference may occur in the vicinity of equipment marked with the following symbol.</p> |
| <p>NOTE1 At 80MHz and 800MHz, the higher frequency range applies.</p> <p>NOTE2 These guideline may not apply in all situations. Electromagnetic propagation is affected by absorption and reflection from structures, objects and people.</p> | | |
| <p>A Field strengths from fixed transmitters, such as base situation for radio (cellular/cordless) telephones and land mobile radios, amateur radio, AM and FM radio broadcast and TV broadcast cannot be predicted theoretically with accuracy. To assess the electromagnetic environment due to fixed RF transmitters, an electromagnetic site survey should be considered. If the measured field strength in the location in which the Handheld ECG monitor is used exceeds the applicable RF compliance level above, the Handheld ECG monitor should be observed.</p> | | |

Recommended separation distances between portable and mobile RF communications equipment and the EQUIPMENT or SYSTEM - for EQUIPMENT or SYSTEM that are not LIFE-SUPPORTING

| | |
|----------------------------------------------------------------------------------------------------------------------------------------------------------------------------------------------------------------------------------------------------------------------------------------------------------------------------------------------------------------------------------------------------------------------------------------------------------------------------------|---------------------------------------------------------------|
| Recommended separation distances between portable and mobile RF communications equipment and the Handheld ECG monitor | |
| <p>The Handheld ECG monitor is intended for use in an electromagnetic environment in which radiated RF disturbance is controlled. The customer or the user of the MD100 Handheld ECG monitor can help prevent electromagnetic interference by maintaining a minimum distance between portable and mobile RF communication equipment (transmitters) and the Handheld ECG monitor as recommended below, according to the maximum output power of the communications equipment.</p> | |
| Rated | Separation distance according to frequency of transmitter (m) |

| maximum output power of transmitter (W) | 150KHz to 80 MHz $d = \frac{3.5}{V_1} \sqrt{P}$ | 80MHz to 800 MHz $d = \frac{3.5}{E_1} \sqrt{P}$ | 800MHz to 2.5 GHz $d = \frac{7}{E_1} \sqrt{P}$ |
|-----------------------------------------|----------------------------------------------------|----------------------------------------------------|---------------------------------------------------|
| 0.01 | 0.1167 | 0.1167 | 0.2334 |
| 0.1 | 0.3689 | 0.3689 | 0.7378 |
| 1 | 1.1667 | 1.1667 | 2.3334 |
| 10 | 3.6893 | 3.6893 | 7.7386 |
| 100 | 11.6667 | 11.6667 | 23.3334 |

For transmitters rated at a maximum output power not listed above, the recommended separation distance in meters (m) can be estimated using the equation applicable to the frequency of the transmitter, where P is the maximum output power rating of the transmitter in watts (W) according to the transmitter manufacturer.

NOTE1 At 80MHz and 800MHz, the separation distance for the higher frequency range applies.

NOTE2 These guidelines may not apply in all situations. Electromagnetic propagation is affected by absorption and reflection from structures, objects and people.

14. Maintenance and Storage

- ◇ Clean the device with a cloth lightly dampened with water, disinfectant alcohol or detergent, and then wipes it dry with a dry cloth.
- ◇ Wipe the electrodes using a cloth dampened with disinfectant alcohol.
- ◇ Do not wipe the device with benzene, gasoline, paint thinner, concentrated alcohol, or other volatile detergents.
- ◇ Do not place objects on top of the device. This could damage the device.
- ◇ Do not disassemble the device. There are no user serviceable parts. Repairs should only be carried out by authorized personnel.
- ◇ Do not sterilize this device in an autoclave, ultraviolet sterilizer or gas sterilizer (EOG, formaldehyde, high density ozone etc.)

- ◇ This device does not require calibration during the expected life cycle.
- ◇ When display the low voltage mark “”, please change the batteries in time. Dispose the used batteries according to the applicable local regulations.
- ◇ Please remove the batteries if the device is not to be used for a long period of time.
- ◇ The environment temperature for transport or storage of the packaged device is $-4^{\circ}\text{F} \sim 131^{\circ}\text{F}$ ($-20^{\circ}\text{C} \sim 55^{\circ}\text{C}$), and the humidity is $\leq 93\%$, no condensation.

**Caution:**

- ◇ Keep operating environment clean, quiet, no erodent and no flammable material. Do not use this device in the environment with too high or too low temperature and humidity
- ◇ If this device is splashed or contaminated by water drop, please stop operating.
- ◇ Please do not use the device at once when it is moved from cold place to the warm and moist place.
- ◇ Please do not use sharp tools to operate any of buttons.
- ◇ Do not immerge the device into liquids or clean the surface with organic liquid, and do not splash liquids on the device.

15. General information about the Heart and ECG Measurements

The heart is a muscular pump controlled by electrical impulses generated by the body. It is divided into two by the septa and each side has two chambers –an atrium and a ventricle-linked by a one-way valve. The left atrium and ventricle control oxygenated blood, and the right atrium and ventricle control de-oxygenated (“used”) blood.

The electrical impulse that causes the heart to beat spreads across the atria, causing the left and right atrium to contract and pump blood into the left and right ventricles respectively. The two ventricles then contract and pump blood out of the heart. The heart muscle then relaxes, or re-polarises, allowing blood to fill up the heart again.

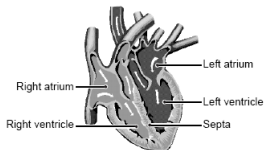

An ECG monitor is able to measure the electrical impulse as it passes across and through the heart, causing the heart to beat. An ECG does not measure the movement of your heartbeat, but rather the electrical activity that causes the heart to beat. The measurements recorded by an ECG monitor, when combined with a medical examination, can help your doctor monitor your heart condition. The ECG measurements recorded by the device are NOT designed or intended for medical diagnosis. Conditions such as arrhythmia and Ischemia can only be diagnosed by a doctor through a special examination.

About the ECG Waveform

The ECG waveform shows the rhythm of your heartbeat during the 30-second measurement and displays the electrical activity causing the heart to beat. The waveform for each heartbeat shows the progress of the electrical impulse across and through the heart.

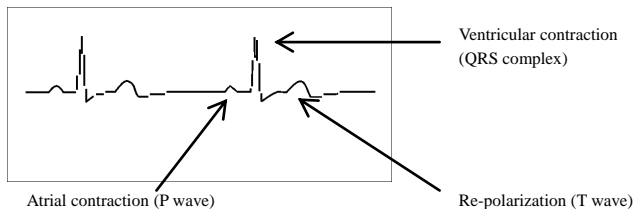

The first peak indicates the spread of the impulse over the atria and the beginning of their contraction. This is known as the P wave. The second peak indicates the spread of impulse over the ventricles and the beginning of their contraction. This is known as the QRS complex. The third peak indicates the activity as the heart relaxes (re-polarization),

and is known as the T wave.

What is Arrhythmia?

Arrhythmia is a condition where the heartbeat rhythm is abnormal due to flaws in the bio-electrical system that drives the heartbeat. Typical symptoms are skipped heartbeats, premature contraction, an abnormally rapid (tachycardia) or slow (bradycardia) pulse. This can be caused by heart disease, ageing, physical predisposition, stress, lack of sleep, fatigue etc. Arrhythmia can only be diagnosed by a doctor through a special examination.

What is Ischemia?

Ischemia is a condition in which insufficient oxygen is supplied to parts of the heart or other parts of the body. This is usually due to a blockage or partial blockage of an artery. Ischemia can only be diagnosed by a doctor through a special examination.

| | |
|---------------------------------------------------------------------------------------------------------------------------------|-----------------------------------------|
|  Beijing Choice Electronic Technology Co.,Ltd. | |
| BailangyuanB1127-1128,Fuxing R,A36 100039 Beijing PEOPLE'S REPUBLIC OF CHINA | |
| EC REP | Eiffestraße 80,20537 Hamburg GERMANY |
| Shanghai International Holding Corp.GmbH(Europe) | |
|  0123 | |