

78M6612 Split-Phase Evaluation Board User Manual

**May 24, 2011
Rev. 1.1
UM_6612_044**

Table of Contents

1	Introduction	5
1.1	Package Contents	5
1.2	System Requirements.....	5
1.3	Safety and ESD Notes	6
1.4	Firmware Demo Code Introduction.....	6
1.5	Testing the 78M6612 Split-Phase Evaluation Board Prior to Shipping	6
2	Installation	7
2.1	Basic Connection Setup.....	8
2.2	Relay Configuration	10
2.3	Optional UART Interface.....	11
2.4	USB Driver Installation.....	13
2.5	Confirm COM Port Mapping.....	14
2.6	Verify Serial Connection to the PC.....	15
3	Calibration.....	17
4	Windows Graphical User Interface (GUI).....	18
4.1	Installing the GUI.....	18
4.2	Changing the Com Port Assignment	19
4.3	Starting the GUI.....	22
5	Schematics, Bill of Materials and PCB Layouts	24
5.1	78M6612 Split-Phase Evaluation Board Schematics	24
5.2	78M6612 Split-Phase Evaluation Board Bill of Materials.....	26
5.3	78M6612 Split-Phase Evaluation Board PCB Layouts.....	28
6	Ordering Information.....	29
7	Included Documentation	29
8	Contact Information.....	29
	Revision History	30

Figures

Figure 1: Split-Phase Energy Measurement Configuration	7
Figure 2: Top Side 78M6612 Split-Phase Evaluation Board Connections	8
Figure 3: Bottom Side 78M6612 Split-Phase Evaluation Board Connections	9
Figure 4: 78M6612 Split-Phase Evaluation Board Application Diagram	10
Figure 5: UART Connector	11
Figure 6: UART Isolator Daughter Card	11
Figure 7: Split-Phase Calibration Test Setup.....	17
Figure 8: 78M6612 Split-Phase GUI.....	23
Figure 9: 78M6612 Split-Phase Evaluation Board Electrical Schematic (1 of 2).....	24
Figure 10: 78M6612 Split-Phase Evaluation Board Electrical Schematic (2 of 2).....	25
Figure 11: 78M6612 Split-Phase Evaluation Board PCB Top View.....	28
Figure 12: 78M6612 Split-Phase Evaluation Board PCB Bottom View.....	28

Table

Table 1: High Voltage AC Connections	9
Table 2: Line 1 versus Neutral Current Sensing Configuration.....	10
Table 3: J12 UART Connector Pin Assignments	12
Table 4: COM Port Setup Parameters.....	15
Table 5: CLI Reset Commands.....	17
Table 6: CLI Relay Commands.....	17
Table 7: CLI Measurement Results Registers	17
Table 8: CLI Input Registers	17
Table 9: CLI Status Registers	17
Table 10: 78M6612 Split-Phase Evaluation Board Bill of Materials.....	26

1 Introduction

The Teridian Semiconductor Corporation (TSC) 78M6612 Split-Phase Evaluation Board is an electrical measurement unit for performing measurements from a single electrical outlet. It incorporates the TSC 78M6612 power and energy measurement IC. The 78M6612 Split-Phase Evaluation Board is connected to a PC through a USB cable such as one provided in the demo kit package. Optionally, the 78M6612 UART TX & RX signals can be accessed via a header for communicating with an external controller or wireless communications module. The Evaluation Board demonstrates the capability of the 78M6612 energy meter controller chip for measurement accuracy and overall system use.

The board is pre-programmed with Split-Phase Demo Firmware in the flash memory of the 78M6612 IC, which allows evaluation of the IC's capabilities.

The 78M6612 Split-Phase energy measurement data and status is read back using an ASCII text string CLI command set. Easy manual operation is performed using HyperTerminal. Optionally, a Windows[®]-based Graphical User Interface (GUI) is provided for simplified access to the following measurement data and controls:

- Power, current, voltage and power factor indicator dials
- Line frequency
- Alarm indicators
- Programmable Alarm thresholds

1.1 Package Contents

The 78M6612 Split-Phase Evaluation Board Demo Kit includes:

- 78M6612 Split-Phase Evaluation Board
- USB Cable Assembly USB A-B 28/24 1.8M (Tyco/Amp 1487588-3)
- +12VDC@1A power supply
- CD with OMU Software and Documentation

1.2 System Requirements

The 78M6612 Split-Phase Evaluation Board requires use of a PC with the following features:

- PC (1 GHz, 1 GB) with Microsoft Windows XP[®] or Windows 2000, equipped with USB port.
- Minimum 1024 x 768 video display resolution.

Windows and Windows XP are registered trademarks of Microsoft Corp.

1.3 Safety and ESD Notes

EXERCISE CAUTION WHEN LIVE AC VOLTAGES ARE PRESENT!



Standard ESD precautions must be taken when handling electronic equipment. The 78M6612 contains ESD protected interfaces.

Do not connect test equipment, ICE emulators or external development boards directly to the 78M6612 Split-Phase hardware. Damage to the 78M6612 and external equipment will occur due to the 78M6612's "high side" reference topology. The 78M6612's V3P3 (i.e. "high side") is connected directly to Neutral (Earth Ground) creating a ground reference disparity with any properly grounded external equipment.

1.4 Firmware Demo Code Introduction

The Firmware Demo Code provides the following features:

- Basic energy measurement data such as Watts, Volts, current, VAR, VA, phase angle, power factor, accumulated energy, frequency, date/time, and various alarm statuses.
- Control of alarm thresholds, calibration coefficients, temperature compensation, etc.

The following setup is used to facilitate performance evaluation between the user at the PC host and the firmware code in the board:

- The Command Line Interface (CLI) via HyperTerminal or comparable terminal emulator on a different operating system. Information about the CLI is presented in Section 3.0.

The 78M6612 Split-Phase Evaluation Board is shipped with Demo Code Revision 1.14c or later loaded in the 78M6612 chip and included on the CD. The code revision can be verified by entering the command `>i` via the command line interface. Firmware for the Evaluation Board can be updated using either the Teridian TFP2 or an in-circuit emulator such as the Signum Systems ADM51 (www.signum.com).

The board components and firmware settings are designed to operate with the following nominal AC electrical ranges:

Voltage	Current	Line Frequency
110-240 VAC	10 mA – 20A	46-64 Hz

1.5 Testing the 78M6612 Split-Phase Evaluation Board Prior to Shipping

Before every 78M6612 Split-Phase Evaluation Board is shipped, the following procedures have been performed at the factory:

- Full Calibration – Precise energy source equipment is used to calibrate the current and voltage. The temperature is also calibrated at the same time.
- Accuracy Test – This "bench" level test ensures the energy accuracy is within $\pm 0.5\%$.

2 Installation

The 78M6612 Split-Phase Evaluation Board is intended for use with a 3-wire single-phase distribution system. This 3-wire single-phase distribution system is typically sourced from a distribution transformer with a single-phase input (primary) winding. The distribution transformer's secondary winding has a center tap which is defined as Neutral. Line 1 and Line 2 exist on either side of Neutral exhibiting a 180° phase shift between them.

The 78M6612 is referenced to Neutral and measures both voltages present on Line1 and Line 2 with respect to Neutral. Additionally, load currents flowing in both Line 1 and Line 2 are measured. The following figure shows the 78M6612 Split-Phase Evaluation Board's measurement inputs with various load configurations.

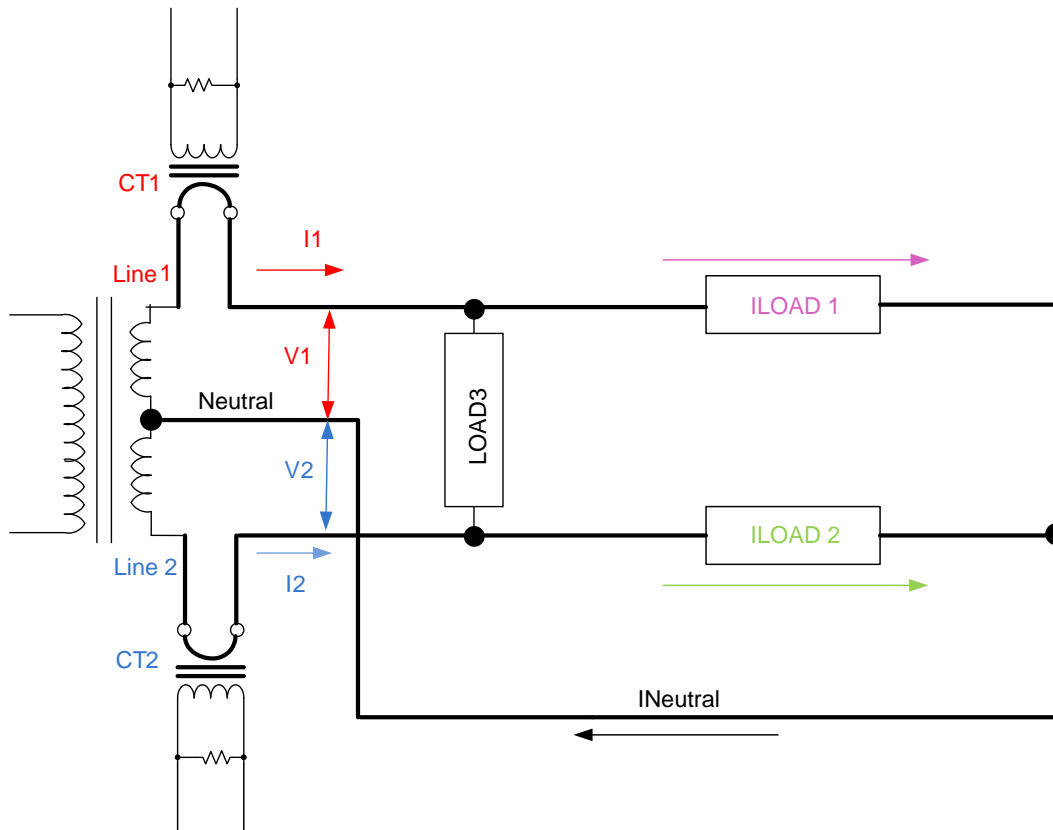

Figure 1: Split-Phase Energy Measurement Configuration

2.1 Basic Connection Setup

Figure 1 and 2 show the basic connections of the 78M6612 Split-Phase Evaluation Board for use with external equipment. The 78M6612 Split-Phase Evaluation Board is powered either by an on-board ACDC switcher or from an external +12VDC power supply. A USB cable provides the communications link between the host PC and the 78M6612 Split-Phase Evaluation Board. The high voltage AC source and load wires connect to spades mounted on the bottom side of the board.

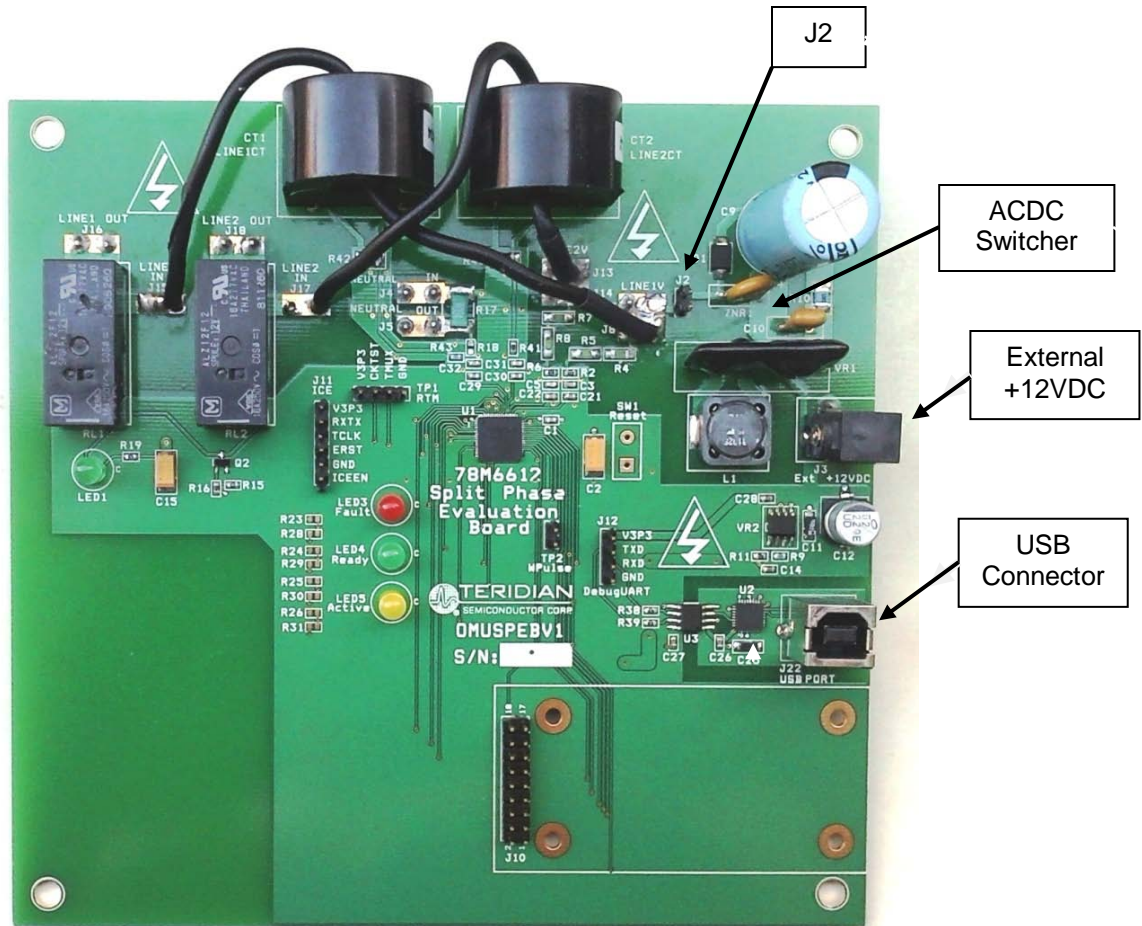

Figure 2: Top Side 78M6612 Split-Phase Evaluation Board Connections

Install jumper J2 when using the on-board ACDC switcher. The switcher draws power from one of the AC inlet phase wires. Remove jumper J2 when attaching an external +12VDC power supply to disconnect the switcher from the AC inlet. The board draws less than 100ma from the external +12VDC supply. Use an external +12VDC power supply which is fully isolated.

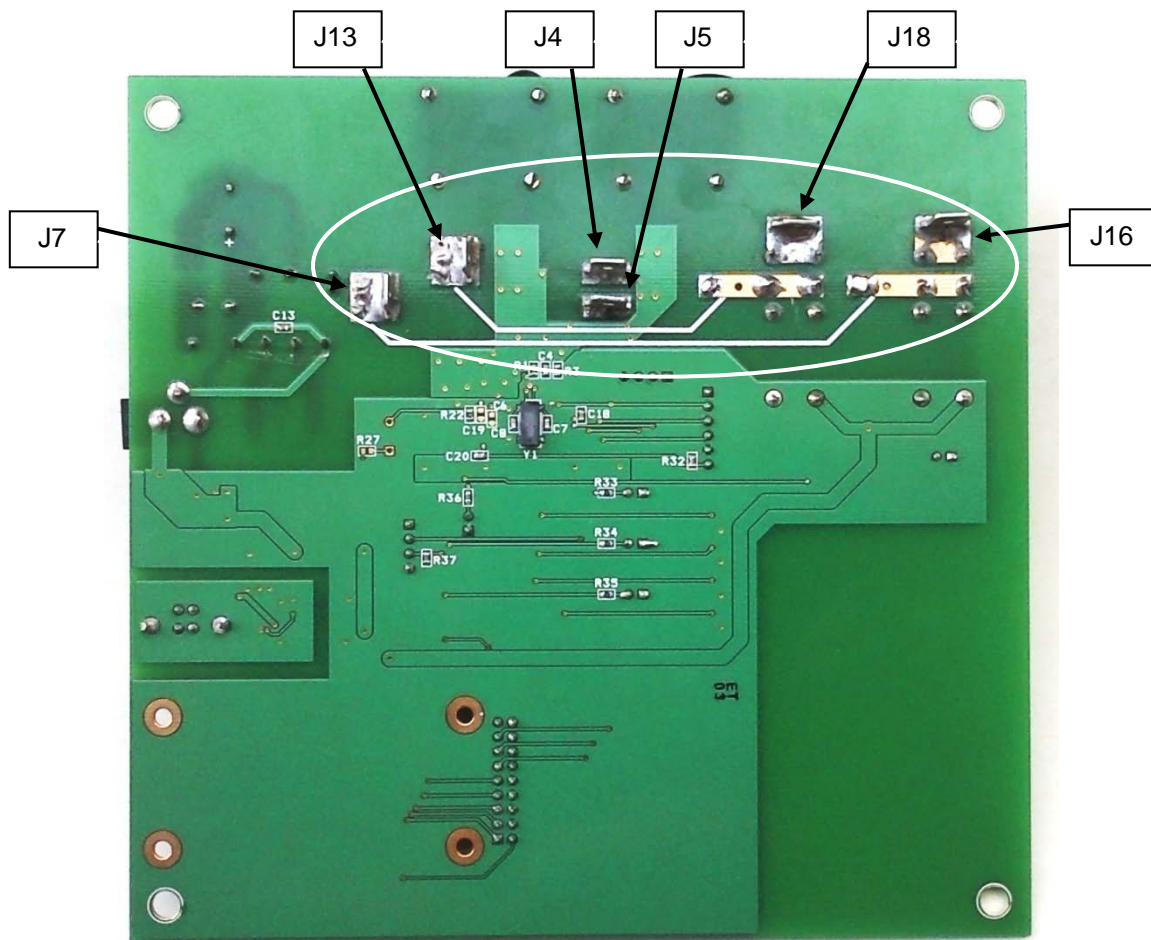

Figure 3: Bottom Side 78M6612 Split-Phase Evaluation Board Connections

The high voltage AC wires attach to the spades located on the bottom side of the board. The following table describes the wiring connections.

Table 1: High Voltage AC Connections

Connector	External Circuit
J4	Neutral – from Source
J5	Neutral – to load
J7	Line 1 – from Source
J13	Line 2 - from Source
J16	Line 1 – to Load
J18	Line 2 – to Load

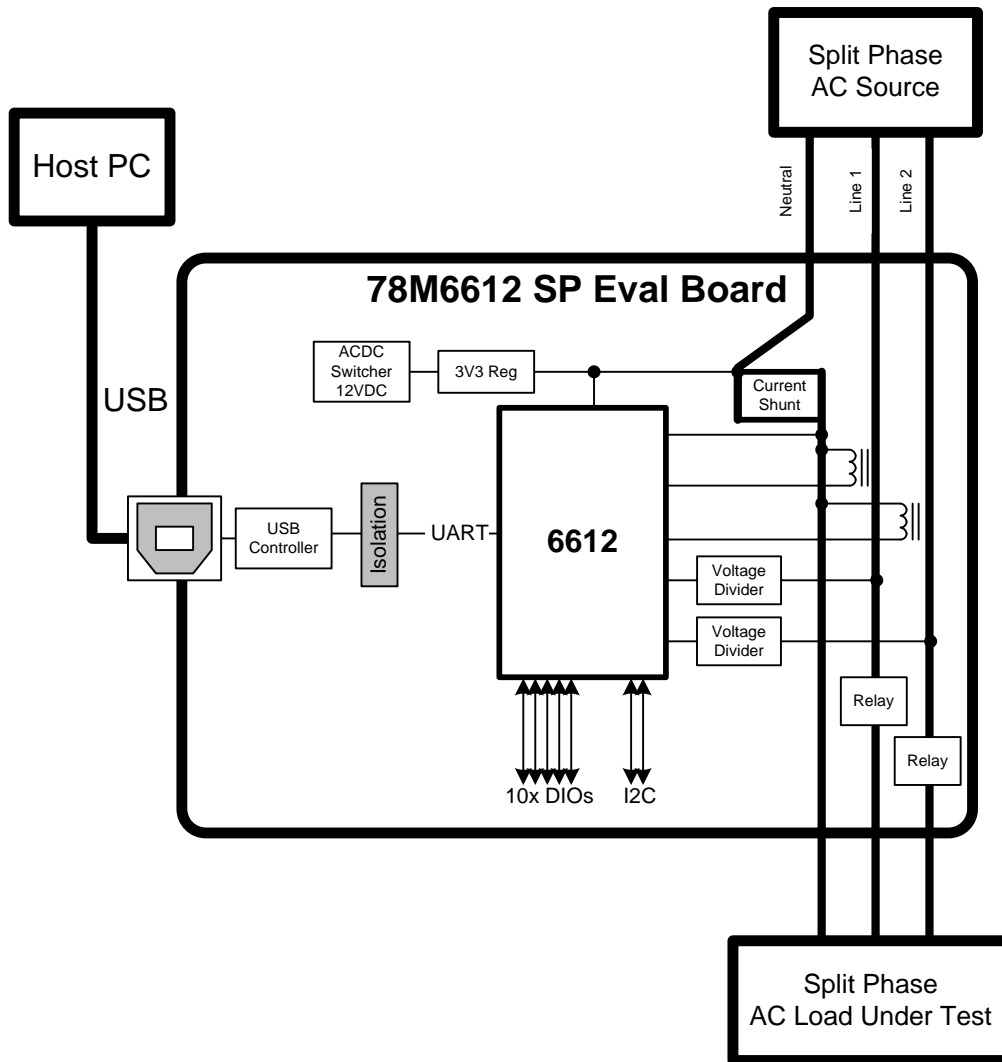

Figure 4: 78M6612 Split-Phase Evaluation Board Application Diagram

The 78M6612 Split-Phase Evaluation Board is preconfigured to measure the Load currents present on Line 1 and Line 2 using two current transformers (CT). Alternatively, the board has provisions to replace the Line 1 CT with a current sensing shunt in series with the Neutral wire. Two resistors (R18 and R43) provide the sensor selection. The following table provides the resistor population options for selecting the CT versus the shunt.

Table 2: Line 1 versus Neutral Current Sensing Configuration

Sensor Configuration	R18	R43
CT – Line 1	No Component	Install 750Ω
Shunt - Neutral	Install 750Ω	No Component

Presently the firmware only supports the CT–Line1 configuration.

2.2 Relay Configuration

The CLI commands support separate Line 1 and Line 2 relays. However, the 78M6612 Split-Phase Evaluation Board uses DIO7 to control both Line 1 and Line 2 relays so that control of power to both remains in sync.

2.3 Optional UART Interface

The 78M6612 Split-Phase Evaluation Board provides an option to bypass the on-board serial USB controller. This option is useful for communicating with an external controller or attachment of a wireless module.

The optional UART interface is accessible via connector J12. Remove the 0Ω resistor R38 to prevent TX contention with the on-board isolator's output, U3.

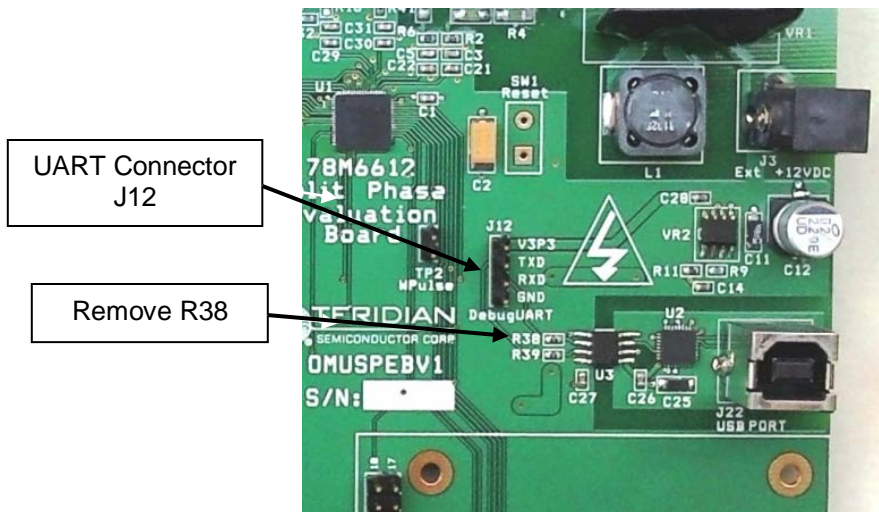

Figure 5: UART Connector

Due to the 78M6612's V3P3 being directly connected to Neutral, the Teridian supplied UART isolator must be inserted between the evaluation board and the external controller. The V3P3 to Neutral connection results in the 78M6612's GND pin being 3.3V below the external controller's GND pin. Additionally, the UART isolator board provides for galvanic isolation between the evaluation board and the external controller hardware.

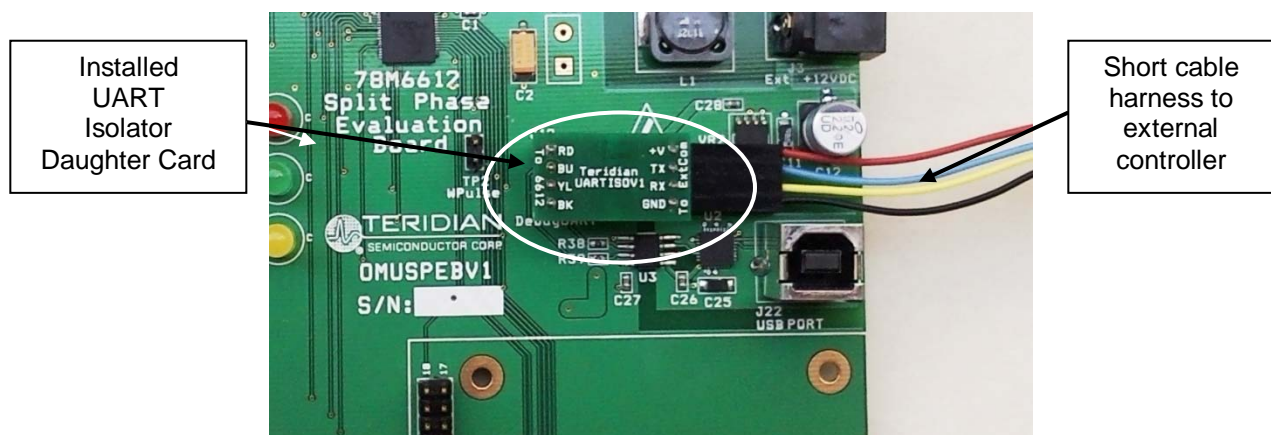

Figure 6: UART Isolator Daughter Card

Table 3: J12 UART Connector Pin Assignments

J12 Pin Number	Identifier	Function
1	V3P3	+3.3V to daughter card
2	TXD	78M6612 TXD output
3	RXD	78M6612 RXD input
4	GND	GND to daughter card

The UART Isolator daughter card maintains the same pin functions on its connector interface to the external controller.

The UART isolator board is not required when using a wireless module. However, use of an antenna with an exposed metal mounting base presents a safety hazard. The other consideration regarding use of a wireless module is the module's transmitting power consumption. The on-board switcher can provide only 100mA (at 3.3V). Use an external power supply if the transmitter's power is greater than 100mA.

2.4 USB Driver Installation

This evaluation kit includes an isolated USB interface for serial communications with a PC. The FTDI USB controller IC FT232R performs the USB functions. The FTDI Windows driver presents a virtual COM port for enabling serial communications. Control of the 78M6612 Split-Phase Evaluation Board can be managed using either a terminal emulation program or using the supplied Windows GUI. The FTDI Windows driver is a certified driver for Windows 2000 and XP.

1. Upon attaching the 78M6612 Split-Phase Evaluation Board to the PC, the Found New Hardware Wizard automatically launches and installs the appropriate driver files. If your PC does not find the FTDI driver files on its local hard disk drive, locate and reference the FTDI USB Driver and Utilities subdirectory on the CD. The FT232R controller is powered from the USB cable and is active even when no power is applied to the 78M6612 Split-Phase Evaluation Board.

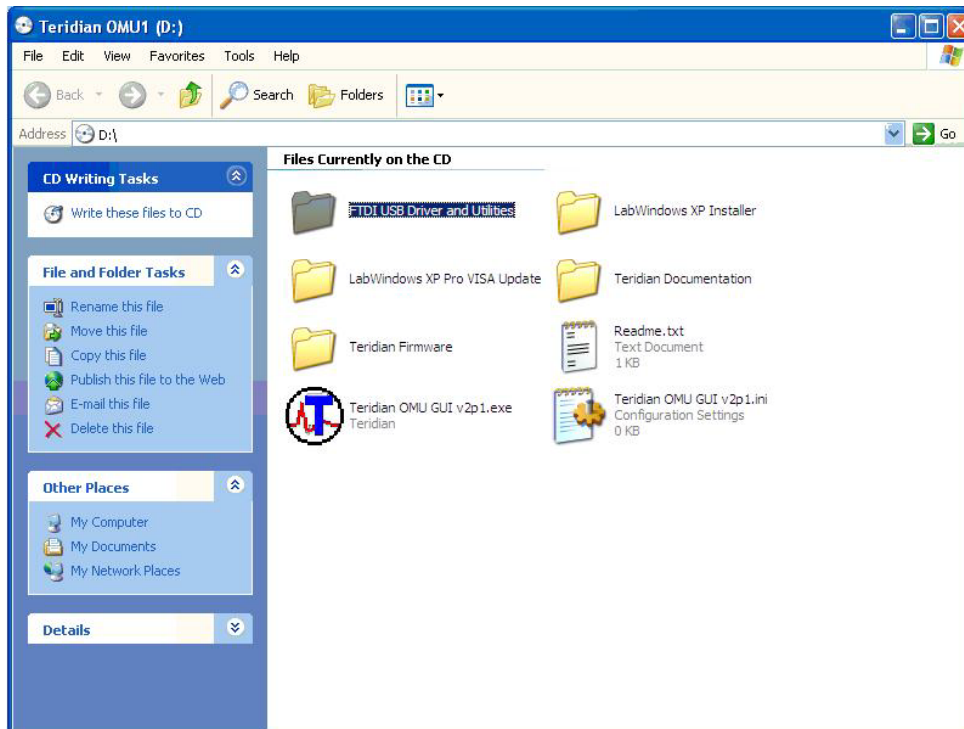

Notes: If an older FTDI driver has been previously installed, it is recommended to remove the older version before installing this newer FTDI driver. Execute the **ftdiClean.exe** utility from the FTDI USB Driver and Utilities subdirectory.

For FTDI driver support on other operating systems, please check FTDI's website at (**Error! Hyperlink reference not valid.**www.ftdichip.com/FTDrivers.htm).

2.5 Confirm COM Port Mapping

- Launch the **Control Panel** and click on the **System** icon.

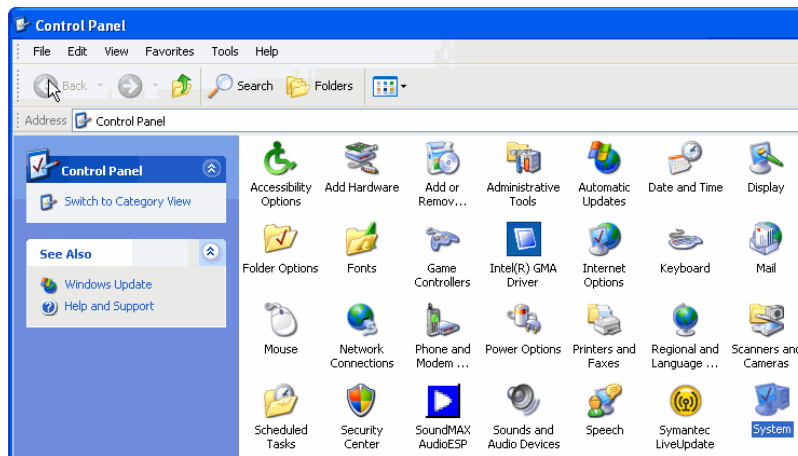

- The **System Properties** screen appears. Click on the **Hardware** tab. Click on **Device Manager**. Under **Ports (COM & LPT)**, look for the **USB Serial Port** assignment.

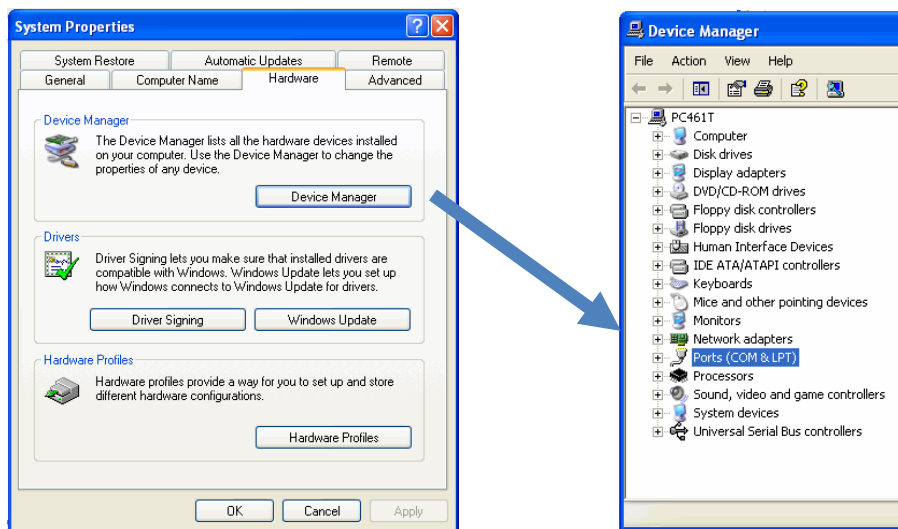

- Take note of the COM port assignment for the USB Serial Port.

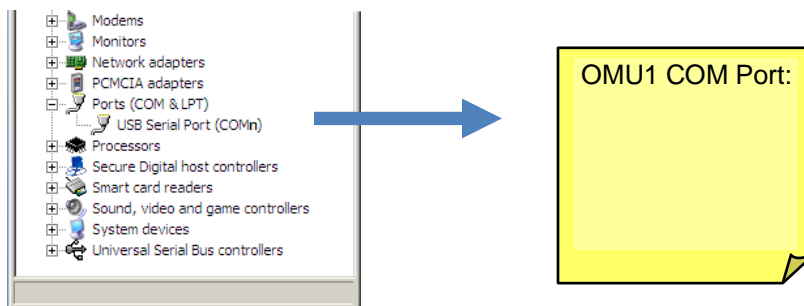

2.6 Verify Serial Connection to the PC

After connecting the USB cable from the 78M6612 Split-Phase Evaluation Board to the host PC, start the HyperTerminal application (or another suitable communication program) and create a session using the communication parameters show in Table 1.

Table 4: COM Port Setup Parameters

Setup Parameter	78M6612
Port speed (baud)	38400
Data bits	8
Parity	None
Stop bits	1
Flow control	Xon/Xoff

HyperTerminal can be found in Windows by selecting **Start → All Programs → Accessories → Communications → HyperTerminal**. The connection parameters are configured by selecting **File → Properties**. The **New Connection Properties** menu appears.

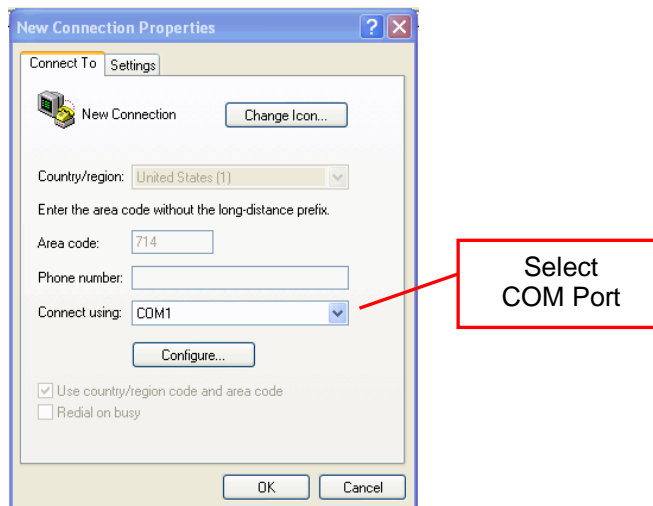

Select the appropriate **COM port** and click **Configure**. The **COMn Properties** menu appears.

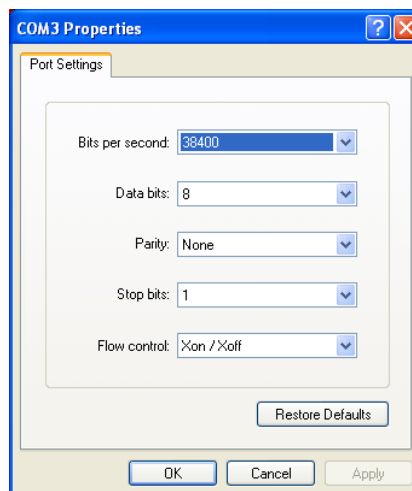

Note that port parameters can only be adjusted when the connection is not active. It may be necessary to click the **Disconnect Button** to disconnect the port.

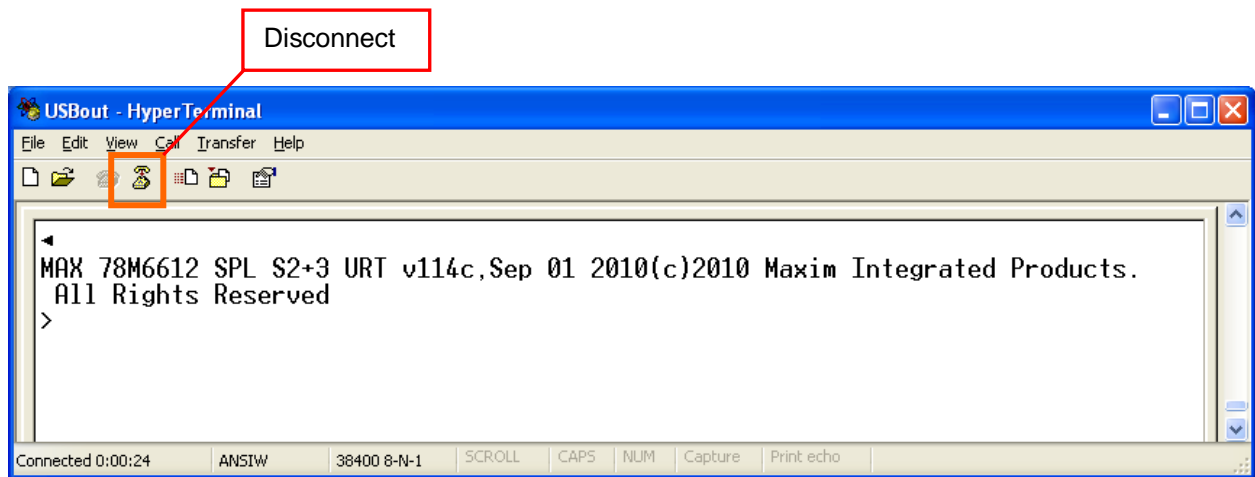

FTDI COM Port Trouble-Shooting

If the FTDI device driver did not install properly, there would be no assigned COM port number for the FTDI controller. Repeat the USB Driver Installation, see Section 2.3.

Microsoft Windows may associate a Ball Point device to the FTDI USB controller. When this occurs a FTDI device COM port assignment is available via HyperTerminal but there is no communications data. Verify if a Ball Point device has been added to the "Human Interface Devices" via the Device manager. Refer to Section 2.4 for access to the Device Manager. If a Ball Point device exists, delete it and unplug and replug the evaluation board's USB cable.

3 Initialization and Calibration

The 78M6613 Split-Phase Firmware includes a relay control routine that initializes the relays in the 'off' position. Until relays are turned 'on' using the TC0 command, only voltage, line frequency, and chip temperature can be measured and reported. To globally turn on or off relays with the Split-Phase Firmware, the following commands should be used.

```
>TC0 (turn on all relays)
>TC3 (turn off all relays)
```

The Split-Phase firmware also includes built in calibration routines. Using the precision source method, a known external voltage source, ambient temperature, and current source (load) is provided to the evaluation board during calibration by Teridian. The routine automatically adjusts coefficients until measured values match known (target) values and saves them to flash memory. It is recommended the user read back and record these calibration coefficients. This will allow the user to re-store the calibration settings should the firmware for the evaluation board be updated in the future. There are four calibration coefficients: one for each voltage input and one for each current input. These four coefficients are read back using the **J8????** command.

```
>J8????
+11290 +11294 +16542 +16544
>_
```

4 Windows Graphical User Interface (GUI)

The 78M6612 Split-Phase GUI displays RMS voltage and current, power, volt-amperes, and power factor for two independent phases as well as totals for these parameters. A true RMS line-to-line voltage is also shown. Indicators are provided for the various alarms.

The 78M6612 Split-Phase GUI is a National Instruments CVI application program. Click on the GUI **setup.exe** file provided on the CD to start the self installer.

4.1 Installing the GUI

After clicking on **setup.exe**, select the installation directories and click on **Next**.

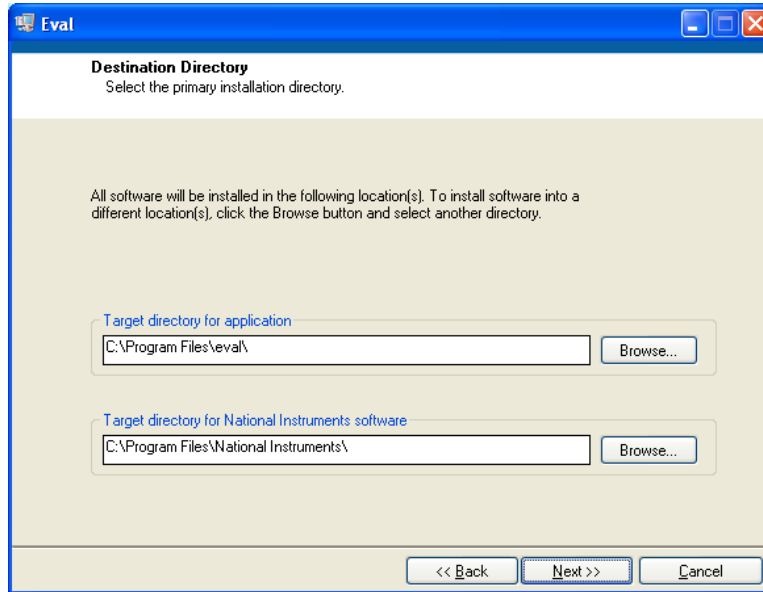

Confirm the installation and click on **Next**.

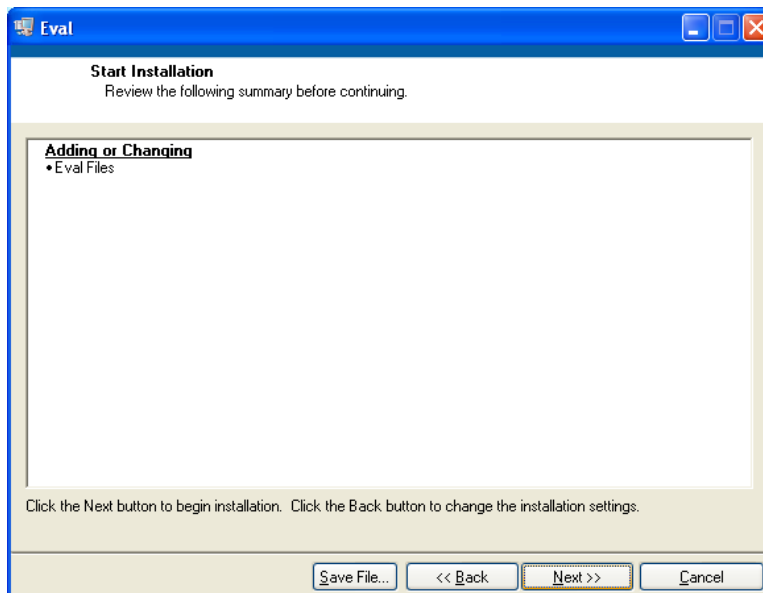

Confirm installation completion and click on **Finish**:

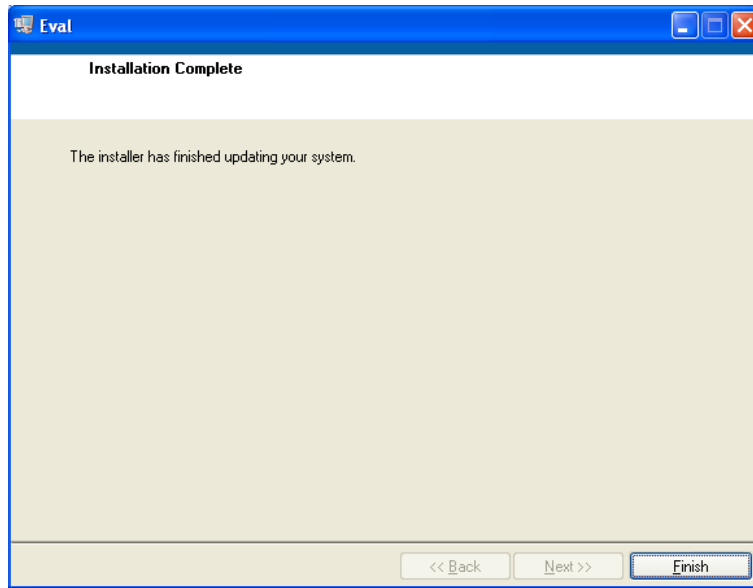

4.2 Changing the Com Port Assignment

The 78M6612 Split-Phase GUI only allows for selecting Com Port assignments of COM1 through COM4. If your FTDI device is assigned a higher Com Port number, open the Device Manager and navigate to the device's Advanced Settings properties to change the Com port number.

Click on the **Device Manager** icon:

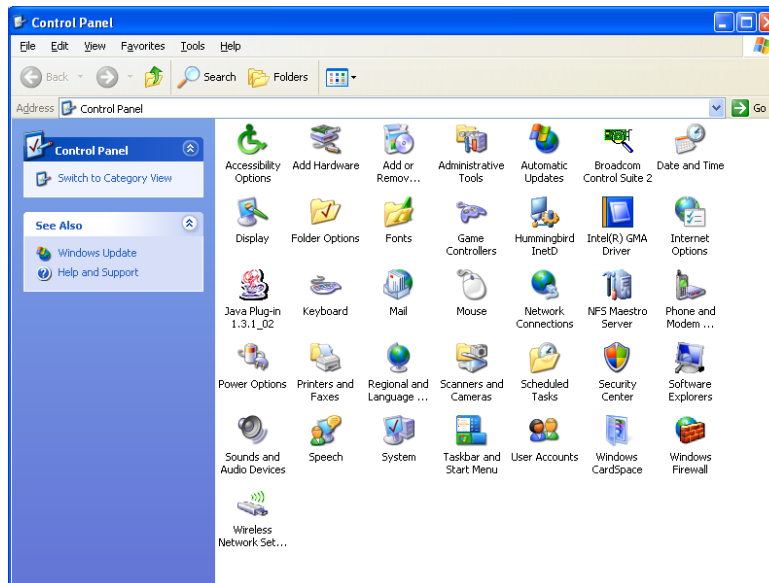

Click on the **Device Manager** button in the Hardware tab:

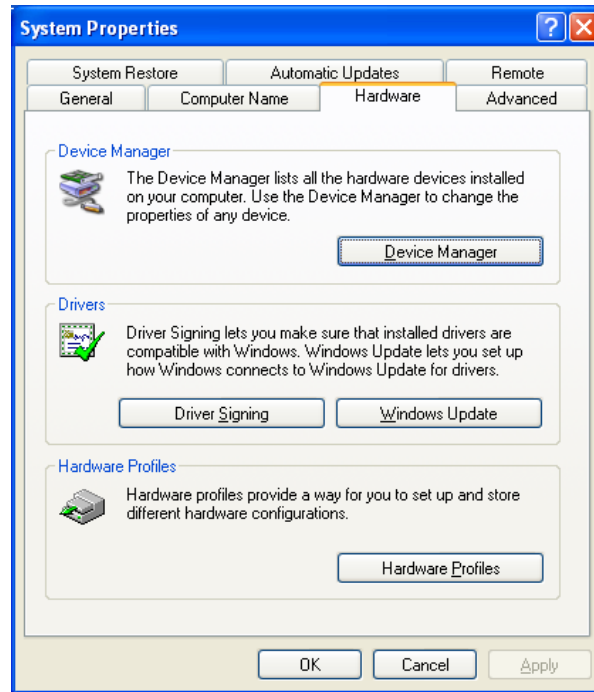

Click on the **Ports (COM & LPT)** line item to display all assigned ports. Then highlight and click **Properties** of the desired USB Serial Port:

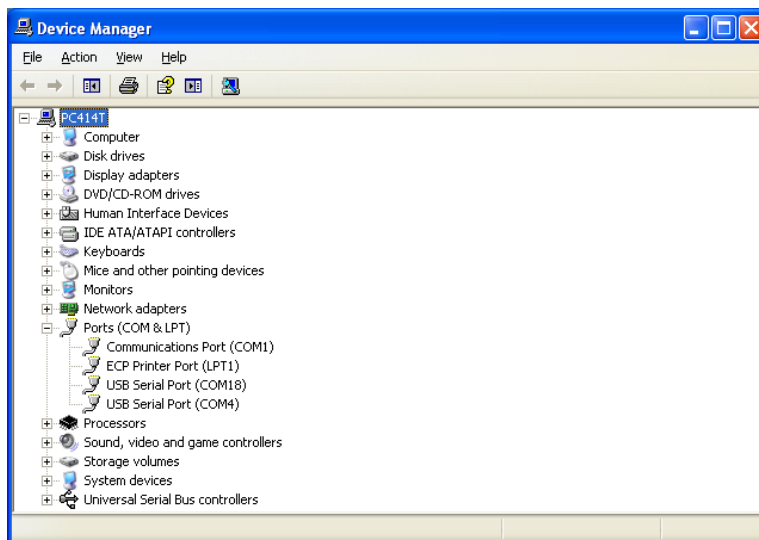

Click on the **Port Settings** tab:

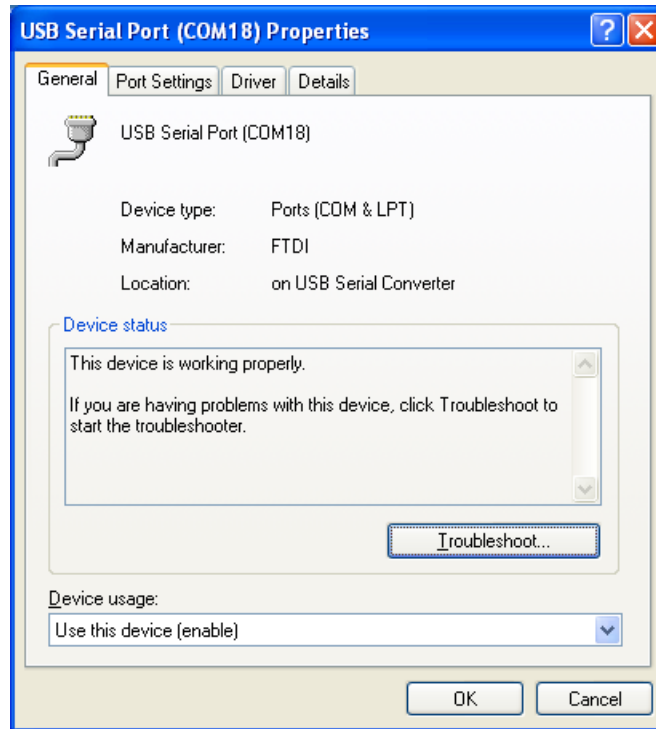

Click on the **Advanced** button:

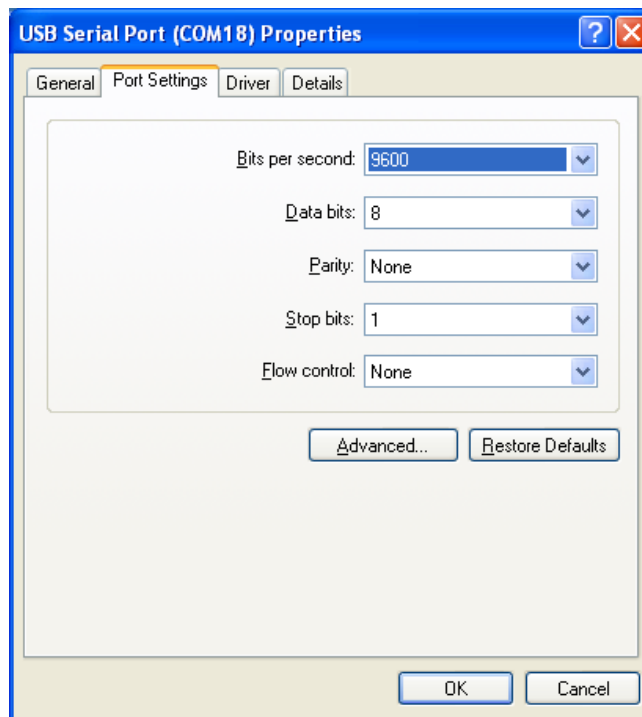

Click on the **COM Port Number drop down arrow** and select an available Com Port between 1 and 4:

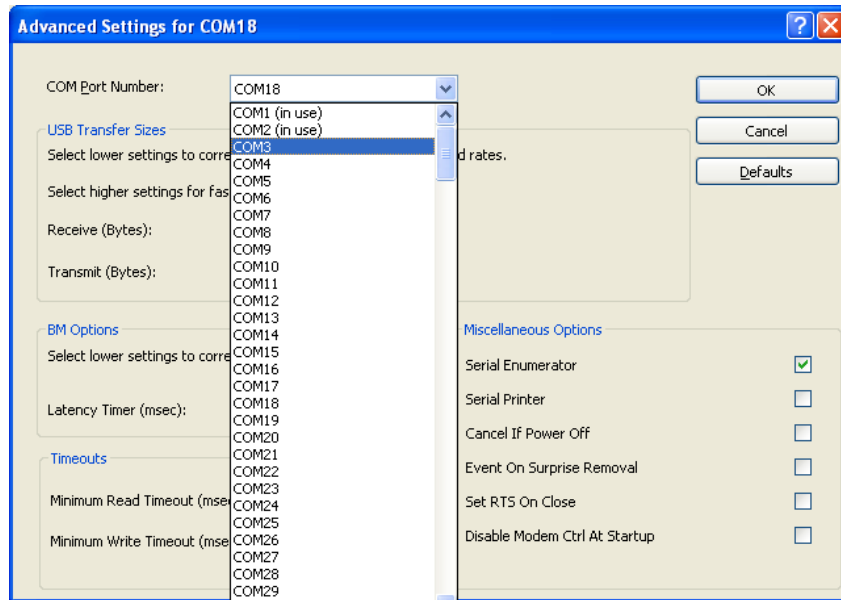

Click OK on the various screens to accept this Com Port assignment change.

4.3 Starting the GUI

Start the 78M6612 Split-Phase GUI by clicking on the GUI's **eval.exe** file via the Start Menu or locate the executable in the target directory selected earlier.

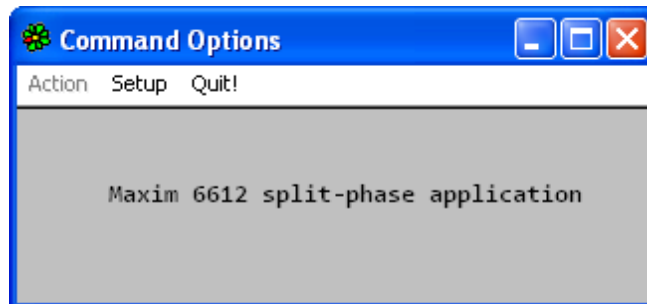

Click on **Setup** to select the Com Port assigned to the FTDI device:

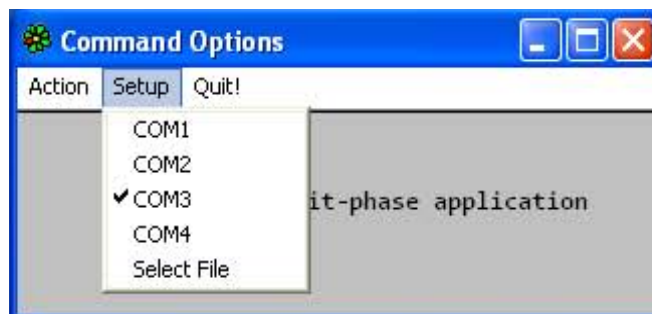

Click on **Action** to display the Measurement panel:

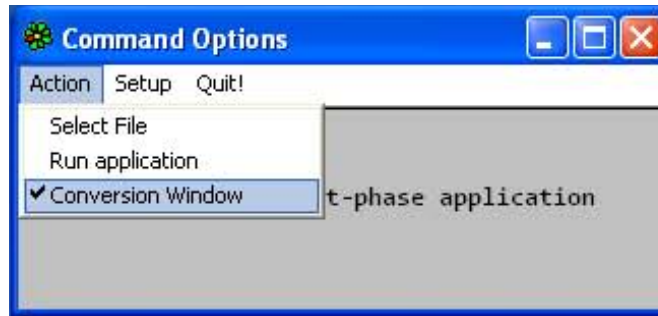

Click on the **Start** and **Stop** buttons to operate the GUI:

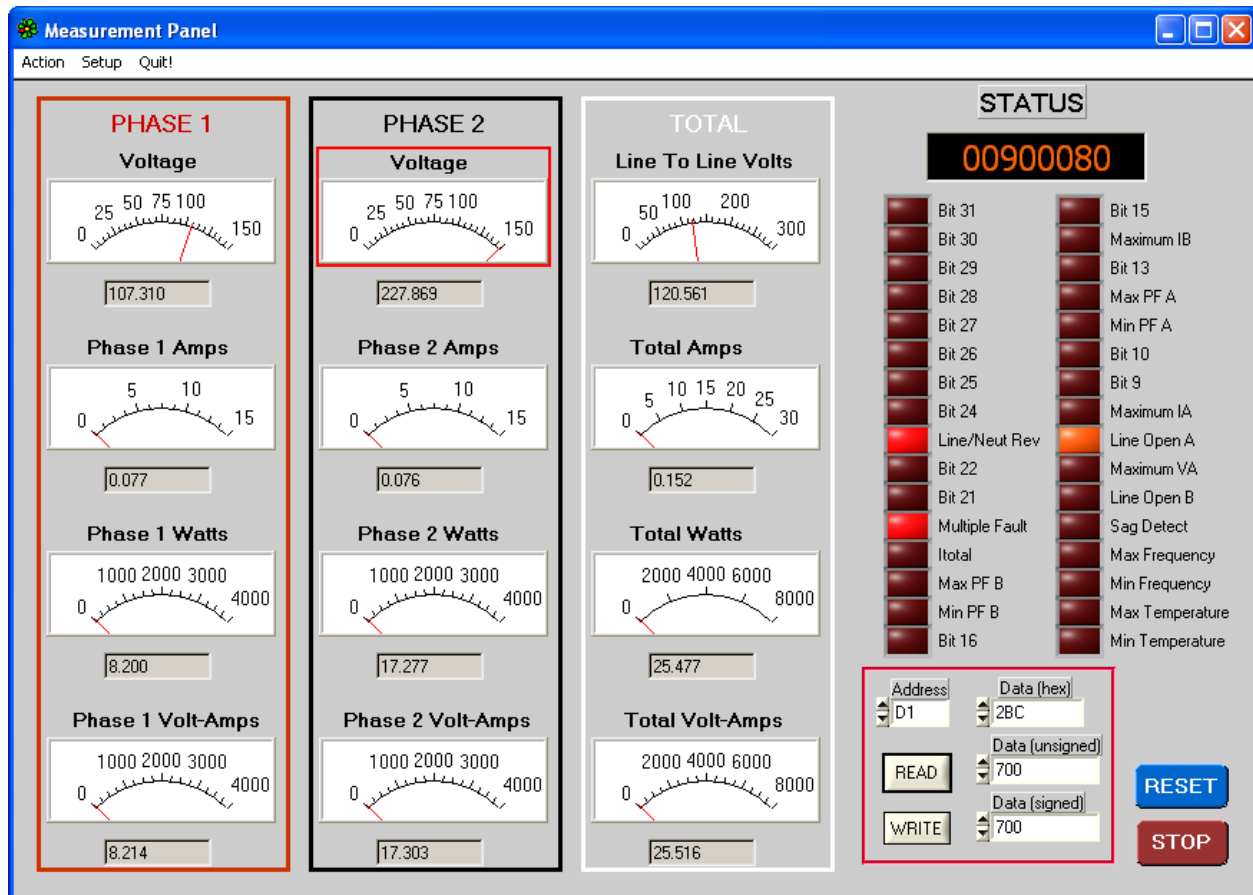

Figure 7: 78M6612 Split-Phase GUI

Write address = **F0** and data = **0** to turn on the relays.

Write address = **F0** and data = **1** to turn off the relays.

5 Schematics, Bill of Materials and PCB Layouts

This section includes the schematics, bill of materials and PCB layouts for the 78M6612 Split-Phase Evaluation Board.

5.1 78M6612 Split-Phase Evaluation Board Schematics

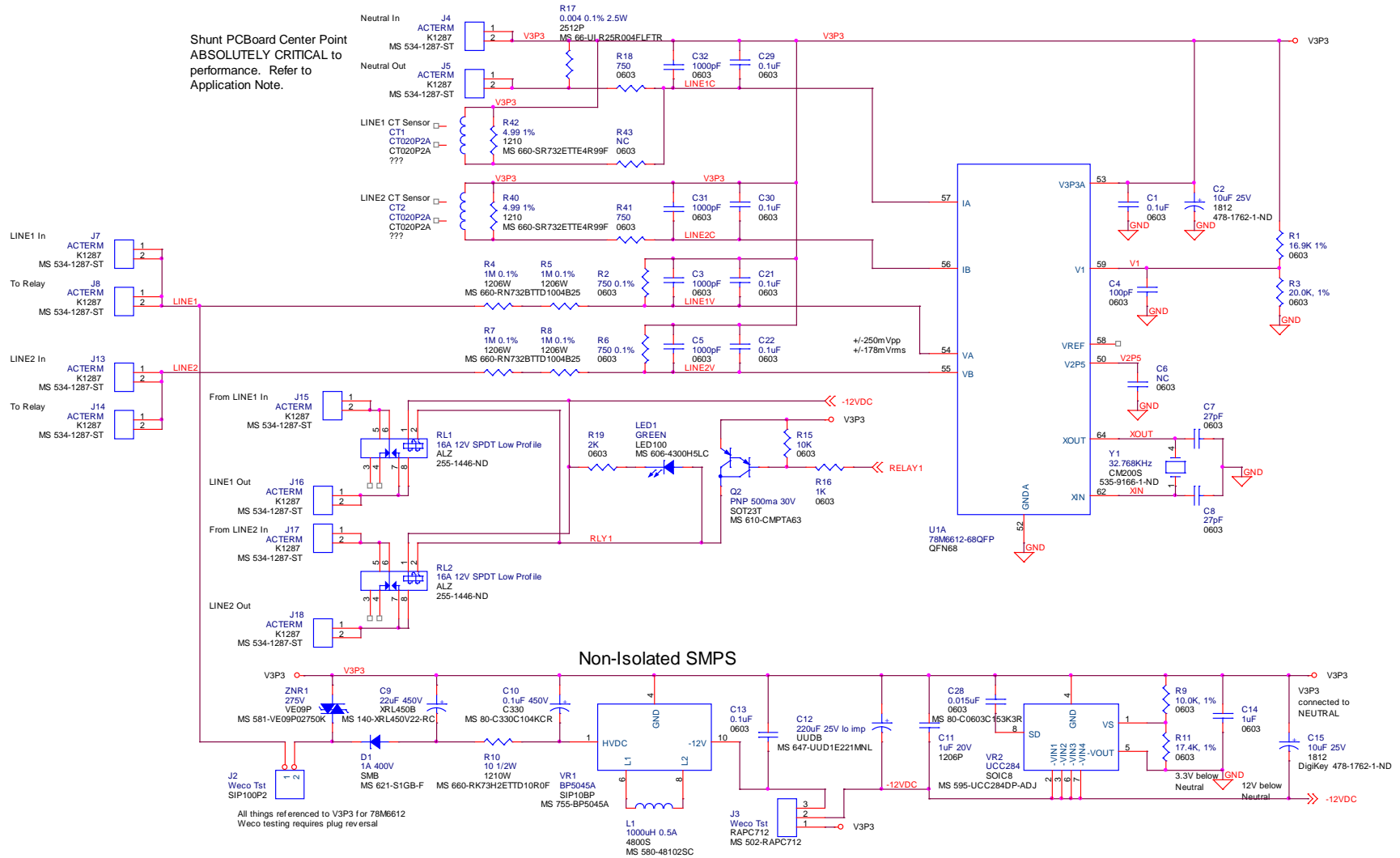

Figure 8: 78M6612 Split-Phase Evaluation Board Electrical Schematic (1 of 2)

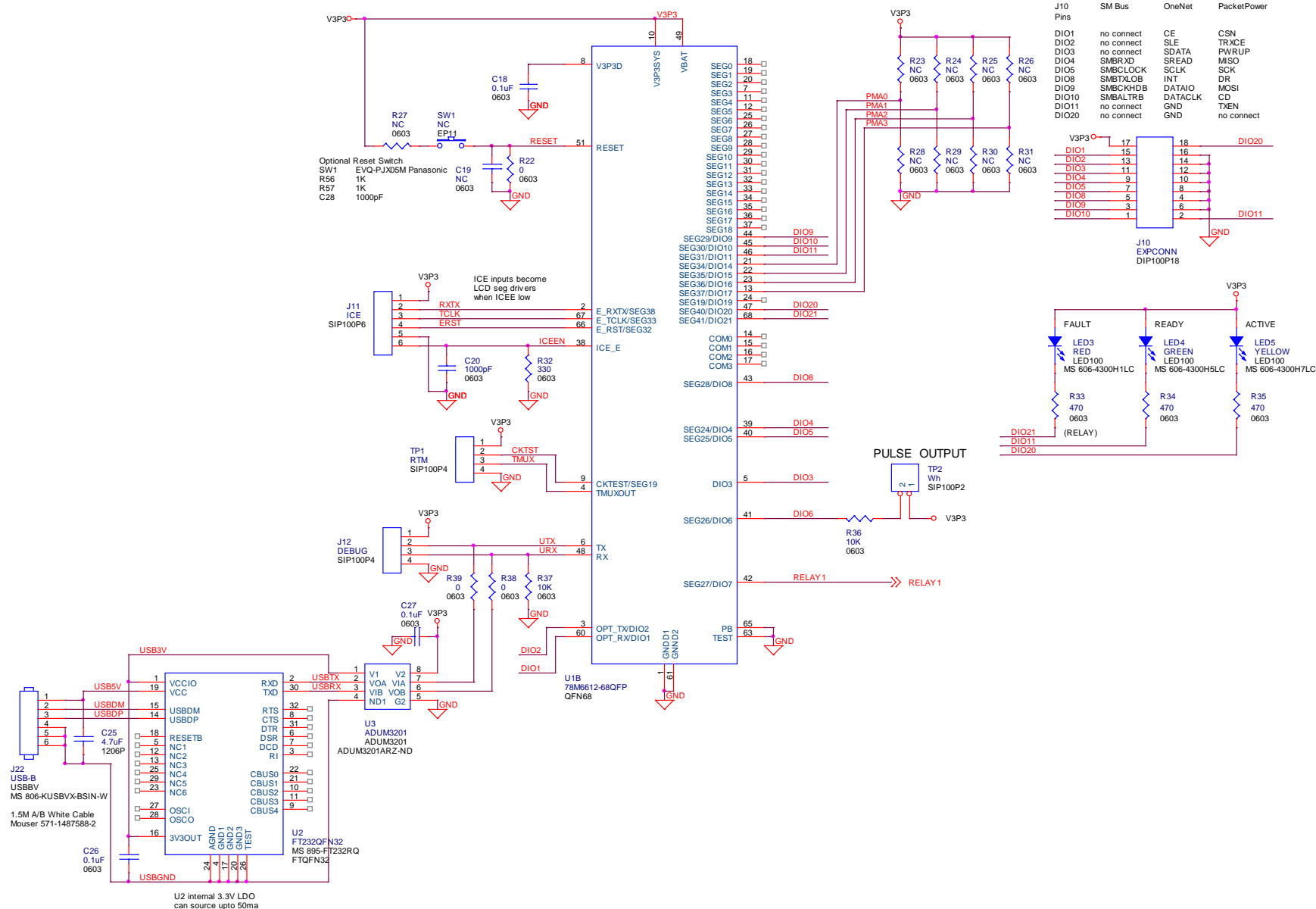

Figure 9: 78M6612 Split-Phase Evaluation Board Electrical Schematic (2 of 2)

5.2 78M6612 Split-Phase Evaluation Board Bill of Materials

Table 5: 78M6612 Split-Phase Evaluation Board Bill of Materials

Item	Qty	Reference	Part	PCB Footprint	Digi-Key/Mouser Part Number	Part Number	RoHS	Manufacturer
1	5	C3,C5,C20, C31,C32	1000pF	RC0603	445-1298-1-ND	C1608X7R2A102K	YES	TDK
2	9	C1,C13,C18, C21,C22,C26, C27,C29,C30	0.1uF	RC0603	445-1314-1-ND	C1608X7R1H104K	YES	TDK
3	2	C2,C15	10uF, 25V	RC1812	478-1762-1-ND	TPSC106K025R0500	YES	AVX
4	2	C7,C8	27pF	RC0603	445-1274-1-ND	C1608C0G1H270J	YES	TDK
5	1	C4	100pF	RC0603	445-1281-1-ND	C1608C0G1H101J	YES	TDK
6	1	C28	0.015uF	RC0603	80-C0603C153K3R	C0603C153K3RACTU	YES	KEMET
7	1	C14	1uF	RC0603	445-1416-1-ND	C1608X5R1C105K	YES	TDK
8	1	C25	4.7uF	RC1206	445-1606-1-ND	C3216X7R1E475K	YES	TDK
9	1	C11	1uF, 20V	RC1206P	445-1592-1-ND	C3216X7R1E105K/0.85	YES	TDK
10	1	C12	220uF,25V,lo imp	UUDB	647-UUD1E221MNL	UUD1E221MNL1GS	YES	NICHICON
11	1	C10	0.1uF, 450V	C330	80-C330C104KCR	C330C104KCR5TA	YES	KEMET
12	1	C9	22uF, 450V	XRL450B	140- REA220M2WBK1625P	REA220M2WBK-1625P	YES	Lelon
13	1	J3	+5VEXT	RAPC	502-RAPC712	RAPC721A	YES	Switchcraft
14	2	J12,TP1	HEADER 4	4X1PIN	S1011E-36-ND	PBC36SAAN	YES	Sullins Connector Solutions
15	1	J11	HEADER 6	6X1PIN	S1011E-36-ND	PBC36SAAN	YES	Sullins Connector Solutions
16	1	J10	HEADER 18	9X2PIN	S2211E-18-ND	PBC18DFAN	YES	Sullins Connector Solutions
17	2	J2,TP2	HEADER 2	2X1PIN	S1011E-36-ND	PBC36SAAN	YES	Sullins Connector Solutions
18	1	J22	USB	USB-B	154-2442-E	154-2442-E	YES	Kobiconn
19	1	R17	0.004, 1%, 2.5W	2512	66-ULR25R004FLFTR	ULR25R004FLFTR	YES	IRC/TT electronics
20	4	R2,R6, R18,R41	750, 0.1%	RC0603	RG16P750BCT-ND	RG1608P-751-B-T5	YES	Susumu
21	2	R40,R42	4.99,1%	RC1210	660-SR732ETTE4R99F	SR732ETTE4R99F	YES	KOA Speer
22	3	R33,R34,R35	470	RC0603	P470GCT-ND	ERJ-3GEYJ471V	YES	Panasonic

Item	Qty	Reference	Part	PCB Footprint	Digi-Key/Mouser Part Number	Part Number	RoHS	Manufacturer
24	4	R4,R5,R7,R8	1M, 0.1%	RC1206	660-RN732BTDD1004B25	RN732BTDD1004B25	YES	KOA Speer
25	1	R1	16.9K,1%	RC0603	660-SR732ETTE16R9F	SR732ETTE16R9F	YES	KOA Speer
26	1	R11	17.4K,1%	RC0603	660-SR732ETTE17R4F	SR732ETTE17R4F	YES	KOA Speer
27	1	R9	10.0K,1%	RC0603	660-SR732ETTE10R0F	SR732ETTE10R0F	YES	KOA Speer
28	1	R3	20.0K,1%	RC0603	660-SR732ETTE20R0F	SR732ETTE20R0F	YES	KOA Speer
29	1	R22,538,R39	0	RC0603	P00GCT-ND	ERJ-3GEYJ000V	YES	Panasonic
30	1	R32	330	RC0603	P330GCT-ND	ERJ-3GEYJ331V	YES	Panasonic
31	3	R15,R36,R37	10K	RC0603	P10KGCT-ND	ERJ-3GEYJ103V	YES	Panasonic
32	1	R16	1K	RC0603	P1.0KGTR-ND	ERJ-3GEYJ102V	YES	Panasonic
33	1	R19	2K	RC0603	P2.0KGTR-ND	ERJ-3GEYJ202V	YES	Panasonic
34	1	R10	10, 1.2W	RC1210W	660-RK73H2ETTE10R0F	RK73H2ETTE10R0F	YES	KOA Speer
35	2	LED1,LED2	GREEN	LED100	606-4300H5LC	4300H5LC	YES	Chicago Miniature
36	1	LED3	RED	LED100	606-4300H1LC	4300H1LC	YES	Chicago Miniature
37	1	LED4	YELLOW	LED100	606-4300H7LC	4300H7LC	YES	Chicago Miniature
38	2	CT1,CT2	50A,1:1000	CT020P2A	582-1084-ND	CR8349-1000-N	NO	CR Magnetics
40	1	RL1,RL2	16A,12V,SPDT	ALZ	255-1446-ND	ALZ12F12	YES	Panasonic
41	1	L1	1000uH, 0.5A	4800S	580-48102SC	48102SC	YES	Murata
42	1	D1	1A, 400V	SMB	621-S1GB-F	S1GB-13-F	YES	Diodes, Inc
43	1	Q2	PNP,500MA,30V	SOT23T	610-CMPTA63	CMPTA63	YES	Central Semiconductor
44	1	ZNR1	275V	VE09P	576-V07E275P	V07E275P	YES	Littelfuse
45	1	U2	FT232	32QFN	895-FT232RQ	FT232QFN32	YES	FTDI
46	1	U3	ADUM3201	8SOIC	ADUM3201ARZ-ND	ADUM3201	YES	Analog Devices
47	1	U1	78M6612	68QFN	—	78M6612-IM	YES	Teridian
48	1	VR2	UCC284	SOIC8	595-UCC284DP-ADJ	UCC284DP-ADJ	YES	TI
49	1	VR1	BP5045A	SIP10BP	755-BP5045A	BP5045	YES	ROHM Semiconductor
50	1	Y1	32.768 KHZ SMD 12.5pF	ABS25	535-9166-1-ND	ABS25-32.768KHZ-T	YES	Abracon

5.3 78M6612 Split-Phase Evaluation Board PCB Layouts

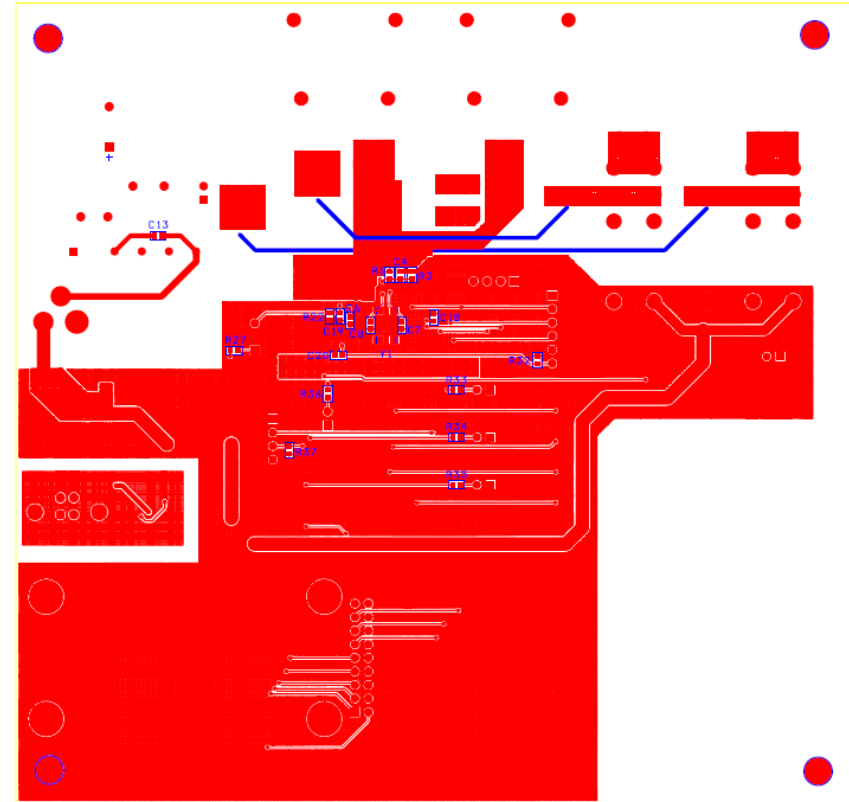
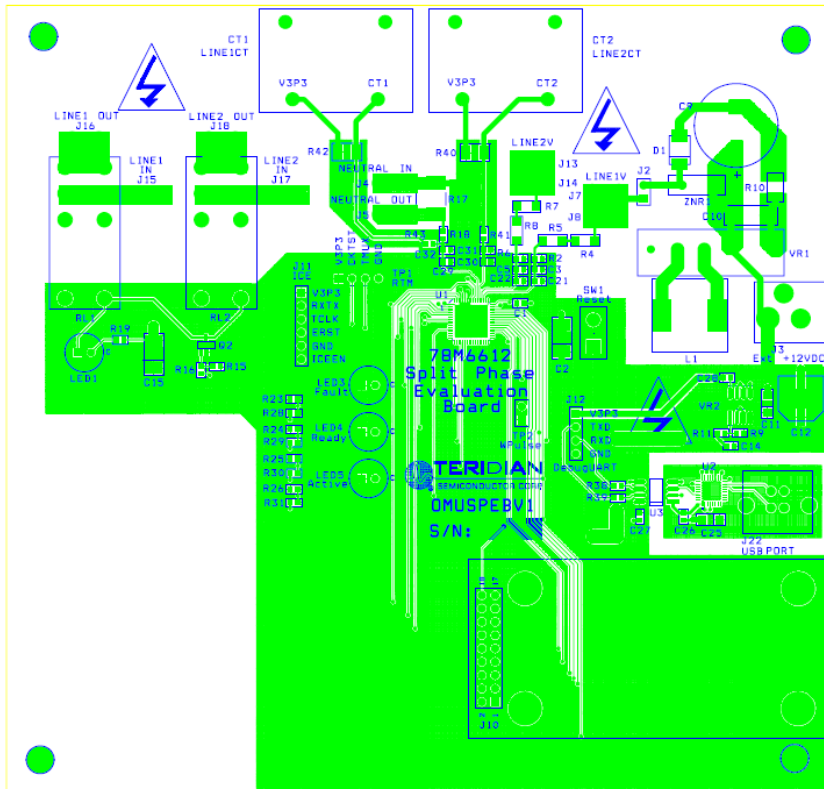

Figure 10: 78M6612 Split-Phase Evaluation Board PCB Top View

Figure 11: 78M6612 Split-Phase Evaluation Board PCB Bottom View

6 Ordering Information

Part Description	Order Number
78M6612 Split-Phase Evaluation Board	78M6612SP-EVM-1

7 Included Documentation

The following 78M6612 documents are included on the CD:

78M6612 Data Sheet

78M6612 Split-Phase Evaluation Board User Manual

8 Contact Information

For more information about Maxim products or to check the availability of the 78M6612, contact technical support at www.maxim-ic.com/support.

Revision History

REVISION	DATE	DESCRIPTION	PAGES CHANGED
1.0	11/8/2010	Initial release	—
1.1	5/24/2011	Added Section 2.2, Relay Configuration. Deleted Section 3, Command Line Interface (CLI); these command descriptions have been moved to the <i>6612_SPL_S2+3_URT_V1_14 Split-Phase Firmware Description Document.</i>	10 17-27