

TSM800

8" Vessel Monitoring and Control Touchscreen

User's Manual

Revision 1.0

Copyright © 2012 Maretron, LLP All Rights Reserved

Maretron, LLP
9014 N. 23rd Ave #10
Phoenix, AZ 85021-7850
<http://www.maretron.com>

Maretron Manual Part #: M003027

Revision History

Rev.	Description
1.0	Original document

Table of Contents

1	General.....	1
1.1	Introduction	1
1.2	Firmware Revision	2
1.3	TSM800 Features	2
1.4	Quick Install.....	2
2	Installation.....	3
2.1	Unpacking the Box	3
2.2	Choosing a Mounting Location.....	3
2.3	Mounting the TSM800.....	4
2.3.1	Mounting Considerations	4
2.3.2	Ergonomics.....	5
2.3.3	Arm Mounting	7
2.4	Connecting the TSM800.....	8
2.4.1	LAN Connection.....	8
2.4.2	USB Device Connection	9
2.4.3	Power Connection.....	10
2.4.4	Grounding Screw	11
2.4.5	Power Sequencing.....	11
2.5	Configuring the TSM800	11
2.5.1	Manually Entering LAN Connection Information	12
2.5.2	Entering N2KServer® or IPG100 Connection Information	14
3	Operating the TSM800.....	17
3.1	Turning the TSM800 On.....	17
3.2	Turning the TSM800 Off.....	17
3.3	Adjusting the Screen Brightness on the TSM800	17
3.4	Using the TSM800	17
4	Maintenance	18
5	Troubleshooting	19
6	Mechanical Drawings.....	20
7	Technical Specifications	21
8	Technical Support.....	23
9	Maretron (1 Year) Limited Warranty	24

Table of Figures

Figure 1 – TSM800 Network Diagram.....	1
Figure 2 – TSM800 Cutout Dimensions (units in mm [inches])	6
Figure 3 – TSM800 VESA Arm Mounting Retention Screw Holes	7
Figure 4 – TSM800 Interface Connector Panel.....	8
Figure 5 – LAN Connection.....	9
Figure 6 – USB Device Connection	9
Figure 7 – Power Connections.....	10
Figure 8 – Attaching Power Cables to Connector	10
Figure 9 – TSM800 Startup Screen	11
Figure 10 – N2KView [®] Window with Tabs Displayed.....	12
Figure 11 – Configuration Dialog	13
Figure 12 – N2KView [®] Window with Tabs Displayed.....	14
Figure 13 – Connections Settings Dialog.....	15

1 General

1.1 Introduction

Congratulations on your purchase of the Maretron TSM800 Vessel Monitoring and Control Touchscreen. Maretron has designed and built your display to the highest standards for years of dependable and accurate service.

The TSM800 is an 8" dedicated touchscreen that comes preloaded with Maretron's N2KView® vessel monitoring and control software. The N2KView® software allows you to configure as many favorite screens as you want with exactly the information you want to see. The TSM800 provides an extremely simple touch interface for monitoring and controlling critical systems from anywhere on the vessel.

The TSM800 is ruggedized for marine use and includes a solid state disk drive to withstand the pounding associated with waves. And since the TSM800 only dissipates 20 watts, there is no need for internal cooling fans that are noisy and wear out causing electronics to overheat and fail. The TSM800 can be mounted outside given the high bright screen and waterproof front.

As an alternative to controlling the TSM800 through the touch screen, the TSM800 includes two USB ports for connecting keyboards, mice, or trackballs. The TSM800 also has an Ethernet port for communicating with an NMEA 2000® network through Maretron's Internet Protocol Gateway (IPG100). Although the TSM800 comes pre-installed with the N2KView® software, a separately purchased license plugged into the IPG100 is required (see IPG100 page for more details). The Ethernet port is also used for connecting Internet Protocol (IP) cameras for viewing within the N2KView® software.

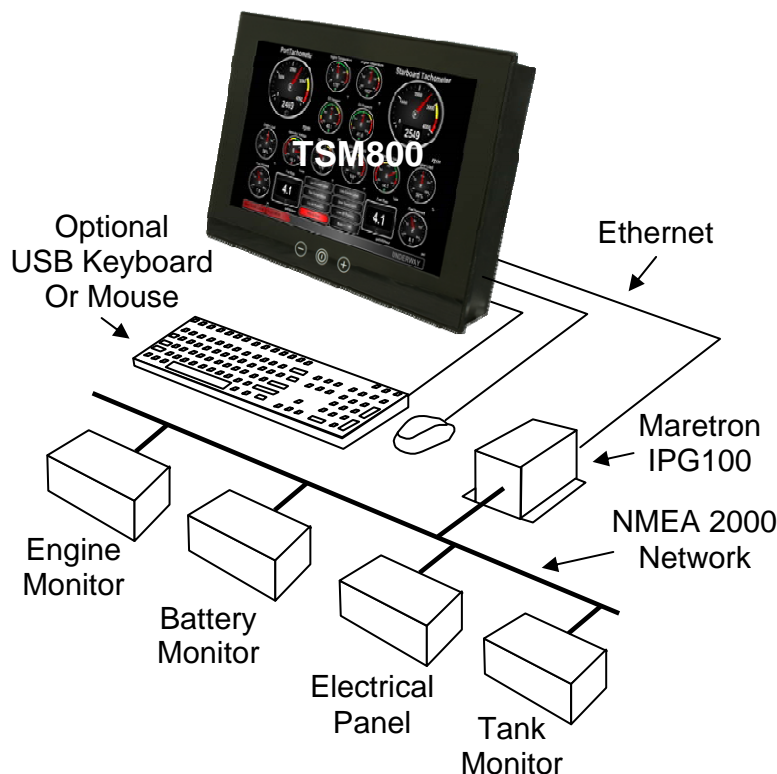

Figure 1 – TSM800 Network Diagram

The Maretron TSM800 is designed to operate within the harsh demands of the marine environment. However, no piece of marine electronic equipment can function properly unless installed, configured, and maintained in the correct manner. Please read carefully and follow these instructions for installation, configuration, and usage of the Maretron TSM800 in order to ensure optimal performance.

1.2 Firmware Revision

This manual corresponds to the TSM800 running N2KView® Version 3.5.0.

1.3 TSM800 Features

The Maretron TSM800 has the following features:

- 8" TFT LCD Panel, LED Backlit
- Widescreen Aspect Ratio 5:3
- 800 x 480 Pixels
- 600 nits Brightness (Optically Bonded)
- Solid State Disk Drive
- Fanless Cooling System
- Flush or VESA Mounting

1.4 Quick Install

Installing the Maretron TSM800 display involves the following five steps. Please refer to the individual sections for additional details.

- Unpacking the Box (Section 2.1)
- Choosing a Mounting Location (Section 2.2)
- Mounting the TSM800 (Section 2.3)
- Connecting the TSM800 (Section 2.4)
- Configuring the TSM800 (Section 2.5)

2 Installation

2.1 Unpacking the Box

When unpacking the box containing the Maretron TSM800, you should find the following items:

- 1 – TSM800 8" Vessel Monitoring and Control Touchscreen
- 1 – TSM800 User's Manual
- 1 – N2KView® Documentation CD-ROM
- 1 – Warranty Registration Card

If any of these items are missing or damaged, please contact Maretron.



NOTE

To prevent damage to chassis corners and/or breaking front glass, please review the illustrations below before handling the TSM800.

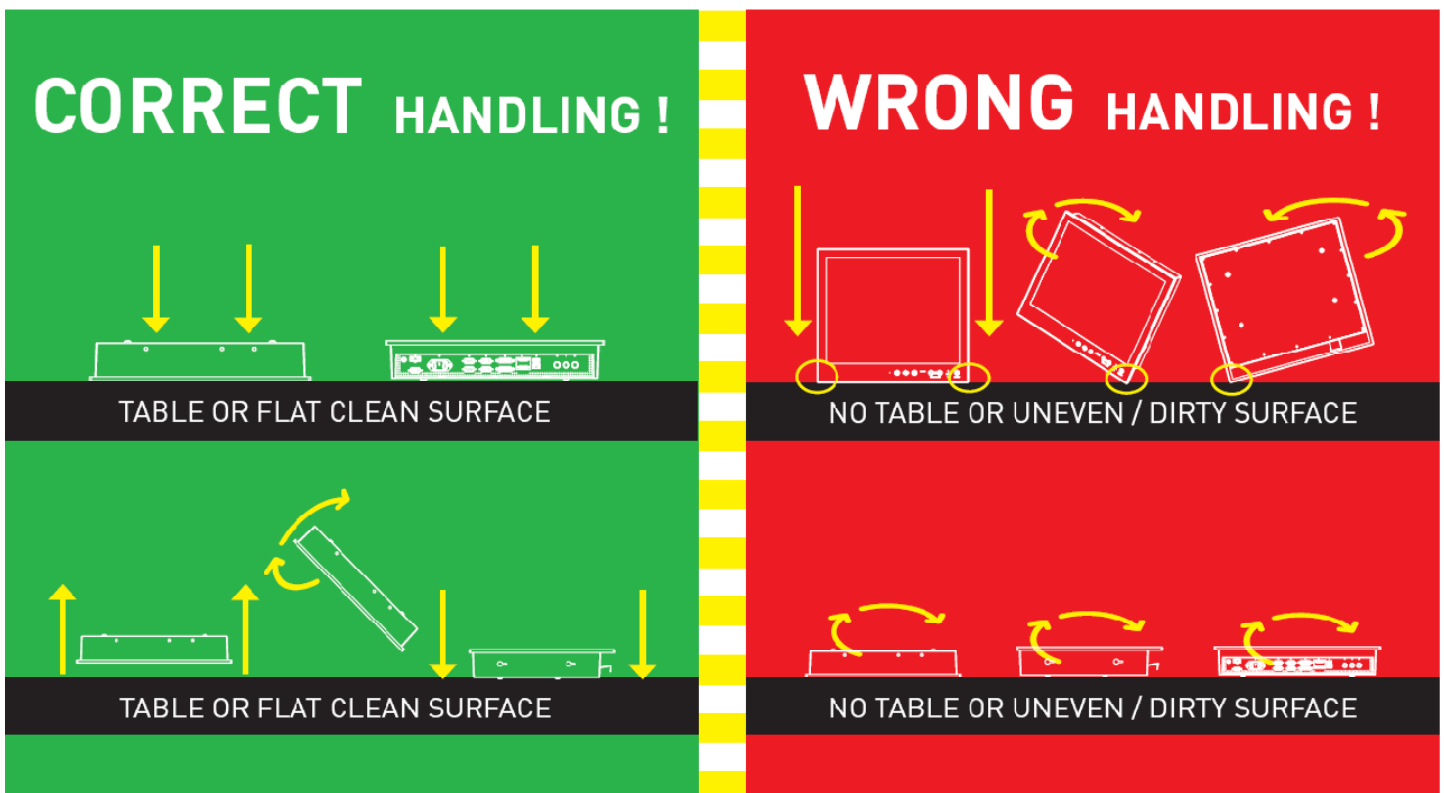

2.2 Choosing a Mounting Location

The TSM800 front panel is splash proof (IEC IP66 rating – protected against the effects of powerful water jets), while the rear of the TSM800 is drip proof (IEC IP22 rating – protected against the effects of dripping water when tilted up to 15°). The TSM800 may be mounted either in an indoor or outdoor location.

Adequate ventilation is a necessary prerequisite for the life of the product. The air inlet and outlet openings must definitely be kept clear; coverings which restrict ventilation are not permissible.

Generally, do not install the unit in a horizontal position (laying down), as this will cause heat to build up inside the unit which will damage the LCD Panel. To prevent this problem, we recommend installing the unit in a vertical position (± 30 degrees) to improve the airflow through the unit.

To further improve the cooling of the unit, we recommend installing Cooling Fans underneath blowing upwards into the unit air inlet. This may be required in high temperature applications and also when there is reason to expect temperature problems due to non-optimal way of mounting.

Exposure to extreme direct sunlight can cause a considerable increase in the temperature of the unit, and might under certain circumstances lead to overtemperature. This point should already be taken into consideration when the bridge equipment is being planned (sun shades, distance from the windows, ventilation, etc.).

Space necessary for ventilation, for cable inlets, for the operating procedures and for maintenance, must be provided.

Proper strain relieve should be installed on cables attached to the TSM800 so that cable breaks will not occur, e.g. during service work.

Do not paint the product. The surface treatment influences on the excess heat transfer. Painting, labels or other surface treatments that differ from the factory default, might cause overheating.

Expose to heavy vibration and acoustic noise might under certain circumstances affect functionality and expected lifetime. This must be considered during system assembly and installation. Mounting position must carefully be selected to avoid any exposure of amplified vibration.

2.3 Mounting the TSM800

The TSM800 has two mounting options, which include:

- Wall/Panel mounting
- Arm mounting (requires purchase of a VESA 75mm mounting arm)

2.3.1 Mounting Considerations

The useful life of the components of all Electronics Units generally decreases with increasing ambient temperature; it is therefore advisable to install such units in air-conditioned rooms. If there are no such facilities, these rooms must at least be dry, adequately ventilated and kept at a suitable temperature in order to prevent the formation of condensation inside the display unit.

Since the TSM800 is fanless, cooling takes place via the surface of the casing. The cooling must not be impaired by partial covering of the unit or by installation of the unit in a confined cabinet.

In the area of the wheel house, the distance of each electronics unit from the magnetic standard compass or the magnetic steering compass must not be less than the permitted magnetic protection

distance. This distance is measured from the centre of the magnetic system of the compass to the nearest point on the corresponding unit concerned.

Units which are to be used on the bridge wing must be installed inside the “wing control console” protected against the weather. In order to avoid misting of the viewing screen, a 25 ... 50 W console-heating (power depending on the volume) is recommended.

When selecting the site of a display unit, the maximum cable lengths have to be considered.

When a product is being installed, the surface base or bulkhead must be checked to ensure that it is flat in order to avoid twisting of the unit when the fixing screws are tightened, because such twisting would impair mechanical functions. Any unevenness should be compensated for by means of spacing-washers.

The grounding screws of the units must be connected to the body of the ship (ground); the wire used should have a cross sectional area of at least 6 mm².

Transportation damage, even if apparently insignificant at first glance, must immediately be examined and be reported to the freight carrier. The moment of setting-to-work of the equipment is too late, not only for reporting the damage but also for the supply of replacements.

The classification is only valid for approved mounting brackets provided by Maretron. The unit shall be mounted stand-alone without any devices or loose parts placed at or nearby the unit. Any other type of mounting might require test and re-classification.

2.3.2 Ergonomics

Adjust the unit height so that the top of the screen is at or below eye level. Your eyes should look slightly downwards when viewing the middle of the screen.

Adjust screen inclination to remain gaze angle to the centre of the screen approximately perpendicular to the line of gaze.

When products are to be operated both from a sitting position and from a standing position, a screen inclination of about 30° to 40° (from a vertical plane) has turned out to be favorable.

The brightness of displays is limited. Sunlight passing directly through the bridge windows - or its reflection – which falls upon the screen workplaces must be reduced by suitable means (negatively inclined window surfaces, venetian blinds, distance from the windows, dark coloring of the deckhead). These units are equipped with optical enhanced technology to reduce reflections and are viewable in direct sun light, but as a general rule the units at the bridge wing area is recommended to be installed or mounted by suitable alignment or bulkhead /deckhead mounting in such a way that reflections of light from the front pane of the display are not directed into the observer’s viewing direction.

The use of ordinary commercial filter plates or filter films is not permitted for items of equipment that require approval (by optical effects, “aids” of that kind can suppress small radar targets, for example).

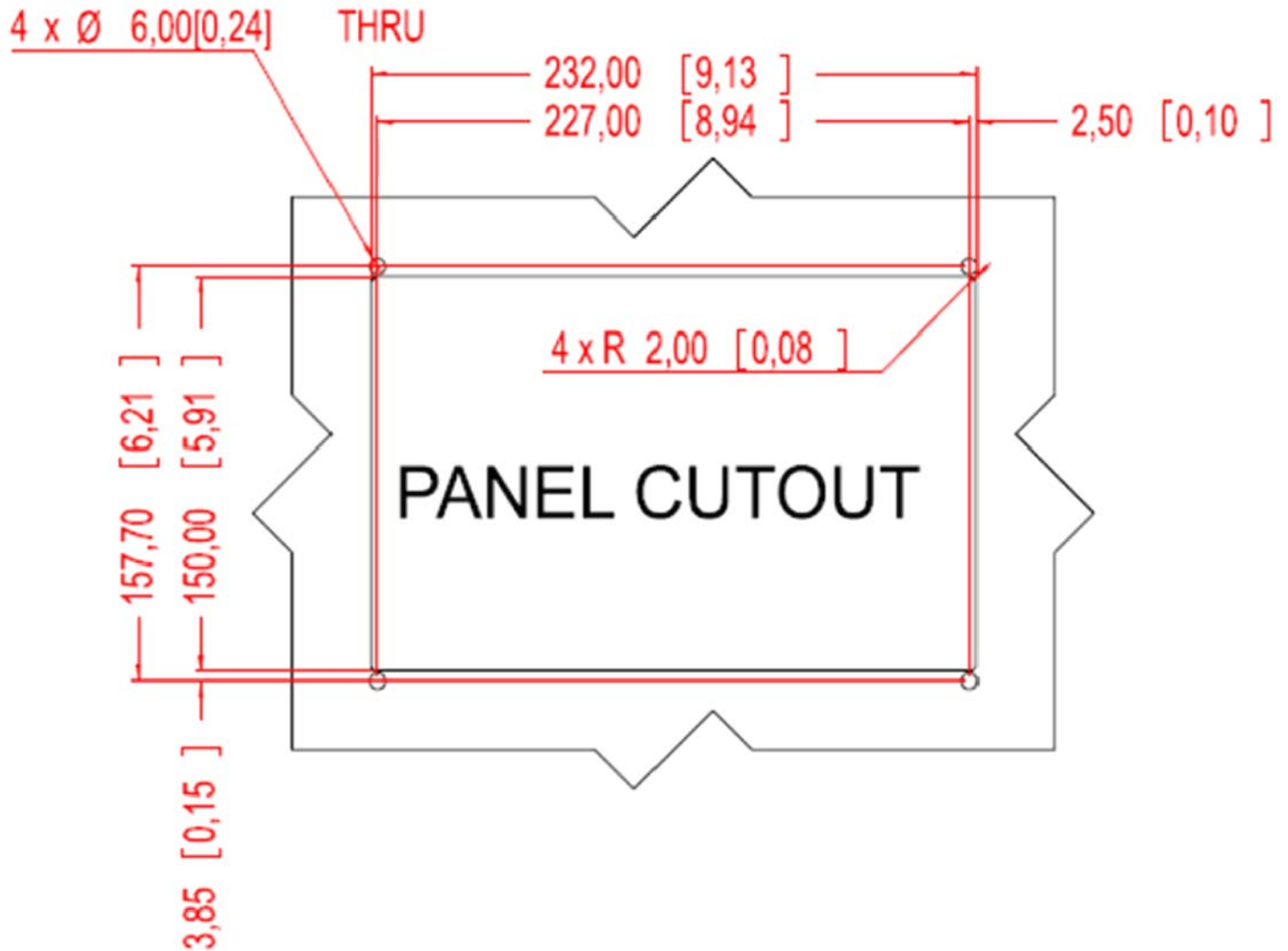

Figure 2 – TSM800 Cutout Dimensions (units in mm [inches])

- Step 1:** Select the position on the panel or wall to mount the TSM800.
- Step 2:** Cut out a section from the panel that corresponds to the rear panel dimensions of the TSM800. Take care that the panel section that is cut out is smaller than the overall size of the front panel of the TSM800 but just large enough for the rear panel of the TSM800 to fit through, according to the dimensions in Figure 2 above.
- Step 3:** Drill four 6mm holes for the M5 studs protruding from the four corners of the front panel according to the dimensions in Figure 2 above.
- Step 4:** Slide the TSM800 through the hole until the frame is flush against the panel.
- Step 5:** From behind the panel, screw the four supplied mounting nuts onto the M5 studs protruding from the rear of the frame, and tighten until the display is firmly secured to the panel.

2.3.3 Arm Mounting

The TSM800 is VESA (Video Electronics Standards Association) compliant and can be mounted on an arm with a 75mm interface pad. To mount the TSM800 on an arm, please follow the steps below.



NOTE

When purchasing a mounting arm please ensure that it is VESA compliant and that the arm has a 75 mm interface pad. If it is not VESA compliant, it cannot be used to support the TSM800.

- Step 1:** Please correctly mount the arm onto the base surface. To do this, refer to the installation documentation that came with the mounting arm.
- Step 2:** Once the mounting arm has been firmly attached to the base surface, lift the TSM800 onto the interface pad of the mounting arm.
- Step 3:** Align the retention screw holes on the mounting arm interface with those in the TSM800. The arm mount retention screw holes are shown in Figure 3.
- Step 4:** Secure the TSM800 to the interface pad by inserting the retention screws through the bottom of the mounting arm interface pad and into the TSM800.

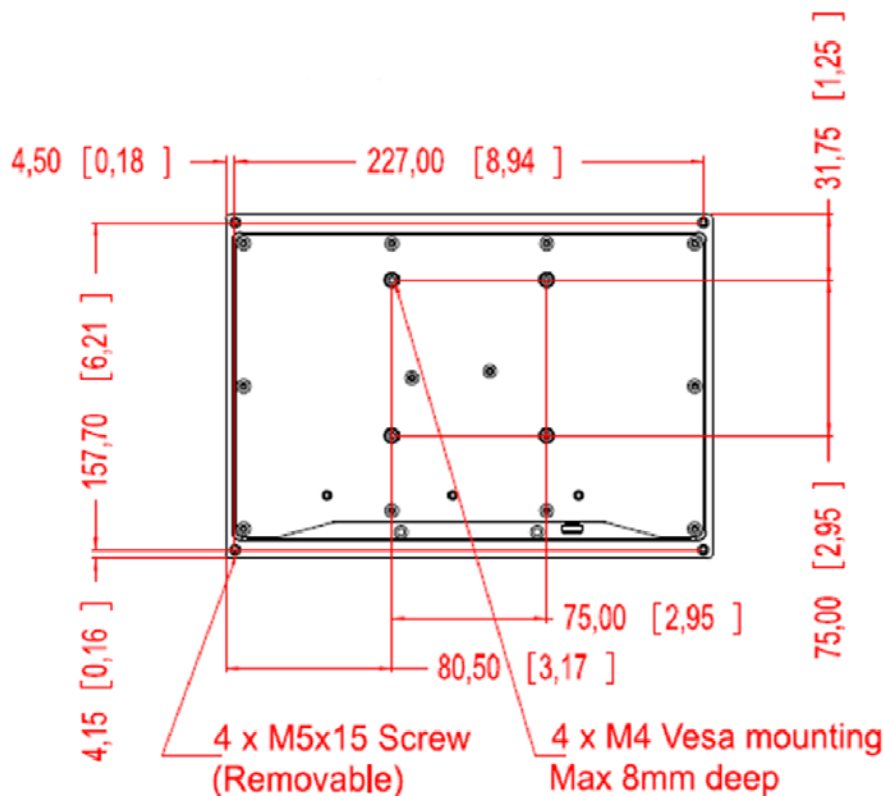

Figure 3 – TSM800 VESA Arm Mounting Retention Screw Holes

2.4 Connecting the TSM800

All I/O interface connections of the TSM800 are found on the bottom panel. The I/O interface panel located on the bottom of the TSM800 has the following I/O interface connectors:

- 2 x 24V DC Power input connector
- 1 x RJ-45 Gigabit Ethernet LAN port
- 2 x USB 2.0 connectors
- 1 x Grounding Screw

The external I/O interface connector panel is shown in Figure 4.

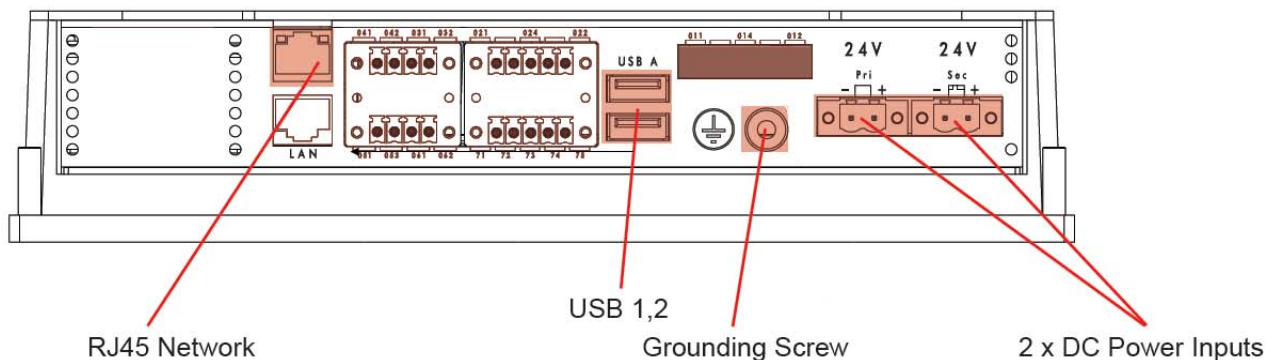

Figure 4 – TSM800 Interface Connector Panel

2.4.1 LAN Connection

There is one external RJ-45 LAN connector (a second RJ-45 connector is plugged at the factory and should not be used). The RJ-45 connector enables connection to an external network. To connect a LAN cable with an RJ-45 connector, please follow the instructions below.

Step 1: Locate an RJ-45 connector on the bottom panel of the TSM800.

Step 2: Align the connector. Align the RJ-45 connector on the LAN cable with the RJ-45 connector on the bottom panel of the TSM800. See Figure 5.

Step 3: Insert the LAN cable RJ-45 connector. Once aligned, gently insert the LAN cable RJ-45 connector into the onboard RJ-45 connector.

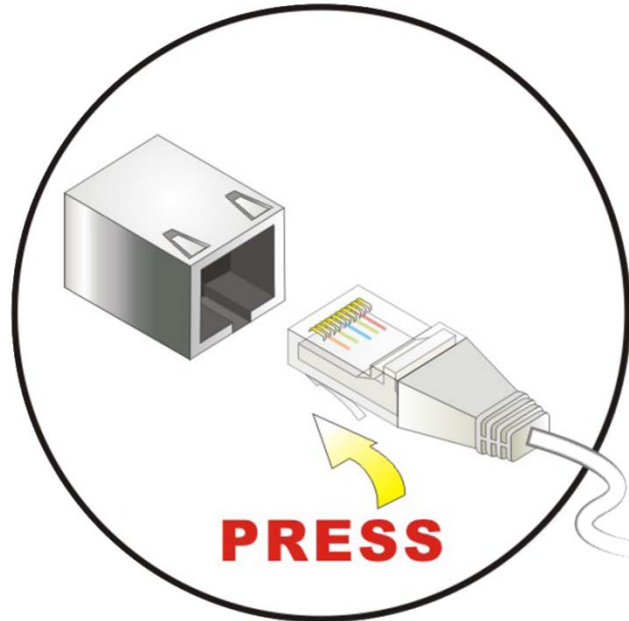

Figure 5 – LAN Connection

2.4.2 USB Device Connection

There are two external USB 2.0 connectors. To connect a USB 2.0 or USB 1.1 device, please follow the instructions below.

Step 1: Locate the USB connectors. The locations of the USB connectors are shown in Figure 4.

Step 2: Align the connectors. Align the USB device connector with one of the connectors on the bottom panel. See Figure 6.

Step 3: Insert the device connector. Once aligned, gently insert the USB device connector into the onboard connector.

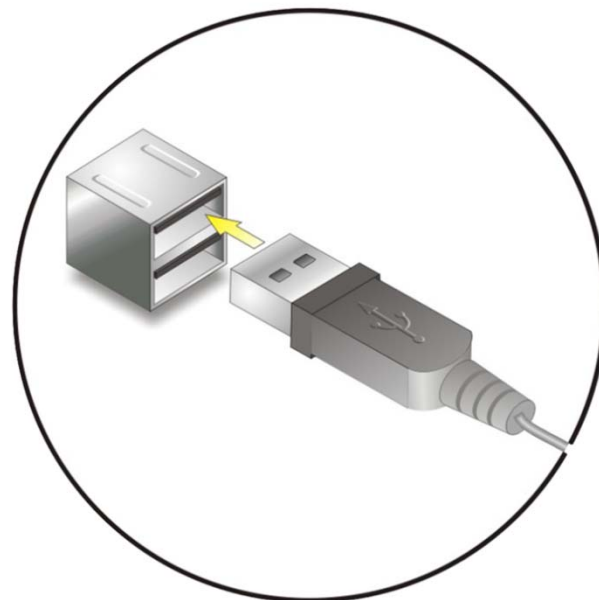

Figure 6 – USB Device Connection

2.4.3 Power Connection

The TSM800 must be connected to a power source (over current protection should be provided and should be sized in accordance with ABYC E-11, AC and DC ELECTRICAL SYSTEMS ON BOATS). The TSM800 provides two sets of independent, galvanically isolated power connections and can run off the power supplied by either connection, allowing for redundant power connection.

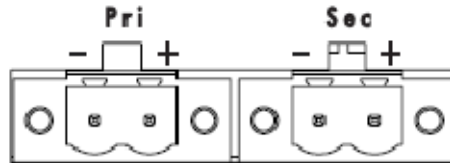

Figure 7 – Power Connections

Connect your DC power cables to the SL-SMT 09F connector block as follows:

Step 1: Unscrew (from top) or make sure that the screw terminals (square area) are fully open, so you can secure the inserted cables correctly to the loose housing connector (it may already be plugged into the unit as per factory installation).

Step 2: Insert cables (from front) and screw / secure the cables by turning the screw on top of the housing to secure the cables properly. Check that the cables are firmly in place and do not appear loose or fall out when pulling gently.



NOTE

Required polarization verification (for instance -/+ for DC power input) should conform to the markings on the connector area of the unit. Ignoring the markings on the unit or its add-on modules might damage the unit and/or external equipment in which end, warranty will be void.

Step 3: Plug the housing into the appropriate connector area of the unit and check again that the cables secured conforms to the markings on the connector area of the unit.

Step 4: Finalize the installation by fasten the screws located in front on each side of the housing connector.

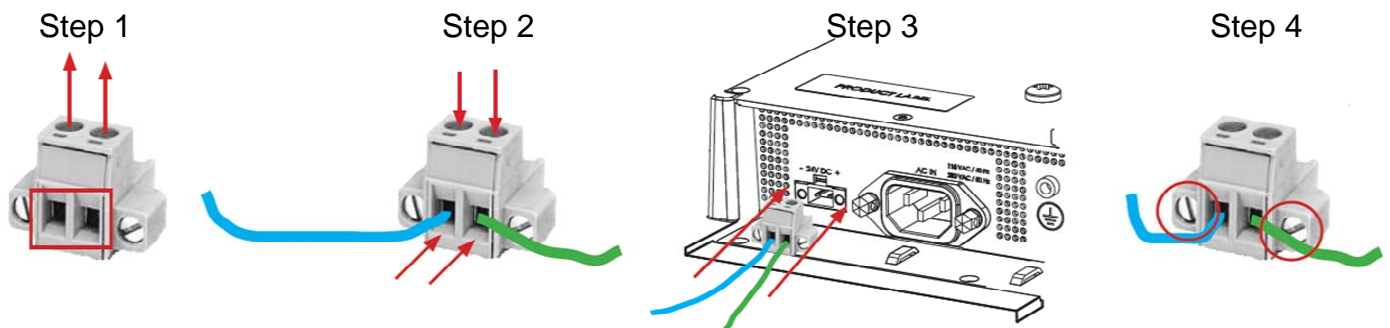

Figure 8 – Attaching Power Cables to Connector

2.4.4 Grounding Screw

The TSM800 is required to be properly grounded via the grounding screw located on the bottom of the unit.

2.4.5 Power Sequencing

When the TSM800 is connected to an appropriate power source, you can use the power switch located on the front panel to turn the TSM800 on or off. If the TSM800 is turned on, then the switches found on the front panel will be illuminated. If the power switch is pushed to power down the TSM800, the front panel switches will be dark.

The TSM800 can also be switched on and off by applying or removing power through an external switch or breaker. Anytime the power is reapplied to the TSM800, it will turn on.

The red LED on the front panel will illuminate anytime power is supplied to the TSM800.

2.5 Configuring the TSM800

In order to use the TSM800, you must already have N2KServer® installed and running on either a Windows PC or on a Maretron IPG100 Internet Protocol Gateway.

You must also have some information as to the configuration of your local area network.

The TSM800 will start up with the following warning screen:

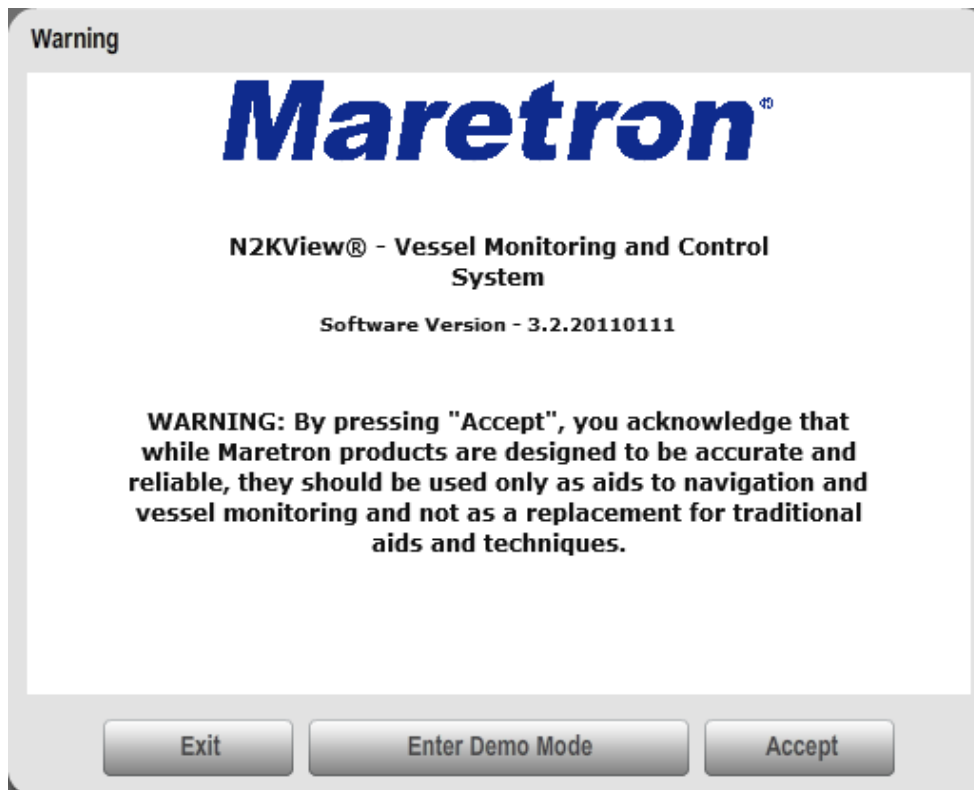

Figure 9 – TSM800 Startup Screen

You are required to press **Accept** and thereby acknowledge this warning message before N2KView[®] will run in Live Mode.

Alternatively, you may **Enter Demo Mode**. In Demo Mode, you will not be able to connect to a Server and view live data; instead simulated data will be provided to stimulate the controls.

The first time you start the TSM800, you must ensure that the device can connect to your LAN (local area network). The TSM800 comes from the factory preconfigured to obtain its LAN connection information from a DHCP (Dynamic Host Control Protocol) server. If your local area network uses a DHCP server, no configuration is necessary, and the TSM800 should be able to successfully connect to the local area network.

2.5.1 Manually Entering LAN Connection Information

If your local area network does not use DHCP, you must manually enter the LAN connection information into the TSM800. This is done through the following steps:

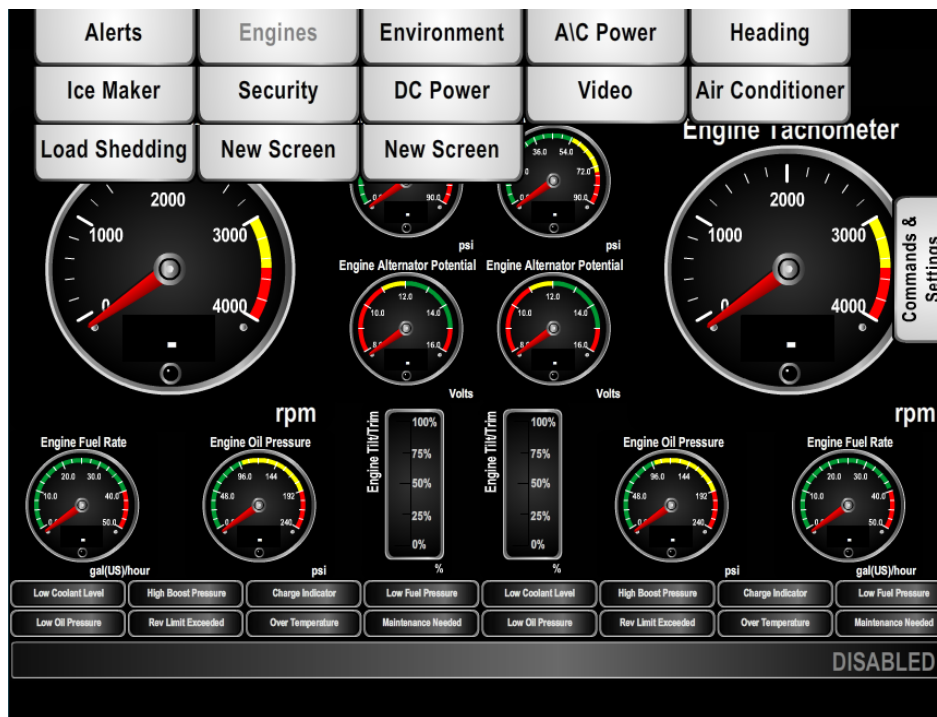

Figure 10 – N2KView[®] Window with Tabs Displayed

- Click anywhere inside the N2KView[®] screen to display the screen tabs as shown in Figure 10 above.
- Click on the “**Configuration**” tab on the right side of the N2KView[®] screen to display the Configuration dialog.



Figure 11 – Configuration Dialog

- c. Uncheck the “**Use DHCP**” box to indicate that your LAN does not use DHCP.
- d. In the “**IP Address**” field, enter the IP address you wish to assign to the TSM800.
- e. In the “**Netmask**” field, enter the netmask value used on your LAN (in most cases, this value will be “255.255.255.0”).
- f. In the “**Gateway**” field, enter the IP address of the default gateway of your LAN.
- g. In the “**Name Server**” field, enter the IP address of a DNS (Dynamic Name Service) Server used on your LAN.
- h. Click the “**Update**” button to make these changes permanent. The screen will go blank for a few seconds while this is being done.

2.5.2 Entering N2KServer® or IPG100 Connection Information

Once the TSM800 has been properly configured to connect to your LAN, you must configure the connection to enable the TSM800 to receive information from an instance of N2KServer® or an IPG100 Server. This is done through the following steps:



Figure 12 – N2KView® Window with Tabs Displayed

- Click anywhere inside the N2KView® screen to display the screen tabs as shown in Figure 12 above.
- Click on the “**Commands & Settings**” tab on the right side of the N2KView® screen to display the Commands & Settings dialog.
- Click on the “**Connections**” button in the Commands & Settings dialog on the right side of the N2KView® screen to display the Connections Settings dialog.

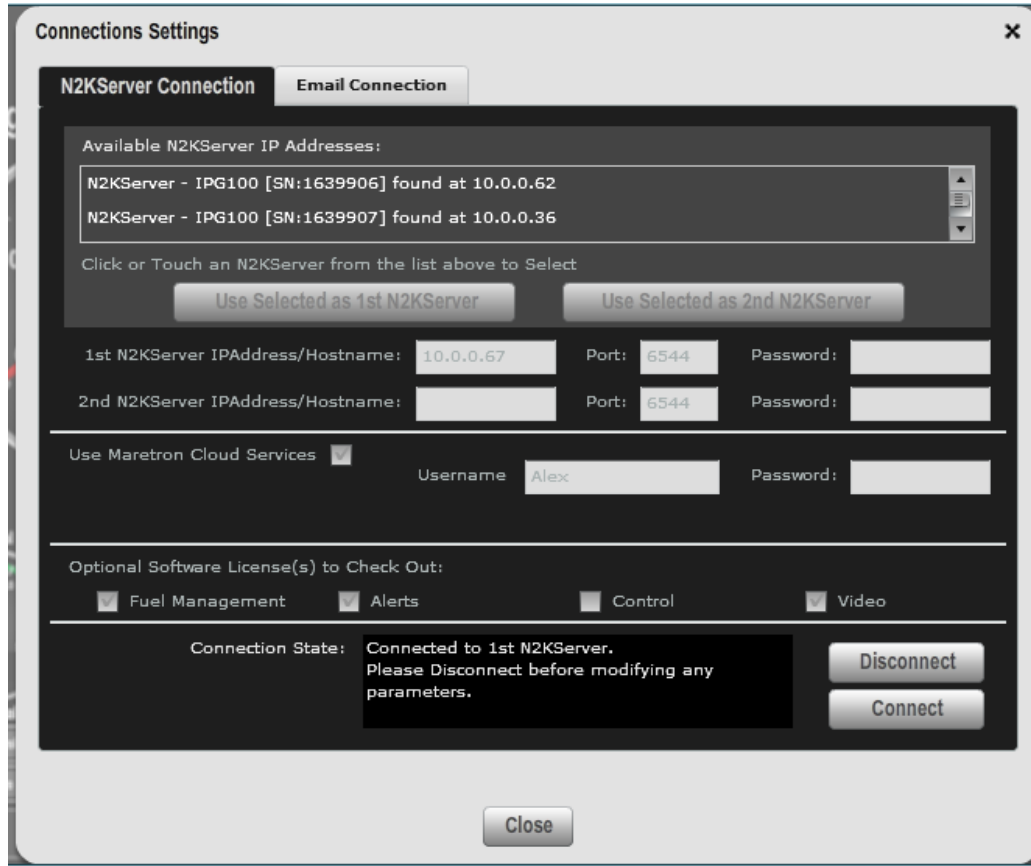

Figure 13 – Connections Settings Dialog

- d. Ensure that N2KView® is not connected to an N2KServer® by pressing the “**Disconnect**” button. While N2KView® is connected you are not able to edit fields.
- e. In the “**Hostname / IP Address:**” text box, enter the IP address of the computer or IPG100 running N2KServer®. If your TSM800 configuration has been programmed to match your LAN, the left side of the N2KServer® Connection window will display the address of any N2KServer® running on a PC or IPG100’s found on the LAN.
- f. Leave the “**Port:**” setting at the initial value of “6544” unless the router between N2KView® and N2KServer® has been set up to do port translation.
- g. In the “**Password:**” text box, enter the same server password that you entered into the N2KServer® Service Manager (for N2KServer® running on a PC), or programmed into the IPG100.
- h. If you have purchased the Platinum Edition of N2KView® and wish to use all of the Platinum Edition features, select “Platinum” from “Features Requested:”. If you have purchased the Basic Edition of N2KView® or you wish to use only the Basic Edition subset of features of N2KView® (leaving the Platinum Edition features available for another copy of N2KView®), select “Basic” from “**Features Requested:**”.
- h. Click “**Connect**”. The “**Connection State:**” part of the window will blink “Connecting...” for a few seconds. It will then either display “Connected” if the connection was successfully made,

or display a message indicating that the connection was not made and suggesting further action to take.

If no data is displayed, please check the following:

1. Make sure the “**Server Password**” entered in N2KView[®] matches the “**Server Password**” entered into the N2KServer[®] Service Manager on the computer running N2KServer[®], or the IPG100, as appropriate. If the server is running on an IPG100, the password in the IPG100 is set from a DSM250 or N2KAnalyzer[®].
2. Make sure the “**Server Address**” matches the IP address of the computer or IPG100 running N2KServer[®].
3. Make sure you have appropriate instruments on the NMEA 2000[®] network to provide the data you are trying to view on the N2KView[®] screen. (To test the network connection between N2KView[®] and the N2KServer[®], you may wish to run N2KServer[®] in “**Simulated Data**” mode).
4. Make sure that the instances that are being monitored correspond to the instances being transmitted. You can set the instance number of the component to “Any” to make sure that there is any data of that type on the bus.

3 Operating the TSM800

3.1 Turning the TSM800 On

To turn on the TSM800, press the power button, located underneath the screen on the front of the TSM800.

3.2 Turning the TSM800 Off

To turn the TSM800 off, use the “Shutdown” administrative tab of the N2KView® software. Alternatively, you can power down the unit by pressing the power button, located underneath the screen on the front of the TSM800.

3.3 Adjusting the Screen Brightness on the TSM800

Touch the illuminated (-) or (+) symbols underneath the screen to adjust the brilliance/brightness of the displayed image.

3.4 Using the TSM800

The TSM800 runs a fully functional version of the Maretron N2KView® software. Please refer to the *N2KView® User's Manual*, included with the TSM800, for detailed operating instructions.

4 Maintenance

Regular maintenance is important to ensure continued proper operation of the Maretron TSM800. Perform the following tasks periodically:

- Clean the unit with a soft cloth. Do not use chemical cleaners as they may remove paint or markings or may corrode the TSM800 enclosure or seals. Do not use any cleaners containing acetone, as they will deteriorate the plastic enclosure. Do not spray cleaning liquids directly onto the TSM800.
- Ensure that the unit is mounted securely and cannot be moved relative to the mounting surface. If the unit is loose, tighten the mounting screws.
- Check the security of the power and network cables connected to the TSM800 and tighten if necessary.

5 Troubleshooting

If you notice unexpected operation of the Maretron TSM800, follow the troubleshooting procedures in this section to remedy simple problems.

Symptom	Troubleshooting Procedure
No activity on the display	Check the connection to the power and network connectors and tighten if necessary Ensure that power is supplied to the connected power cable. Press the power switch located on the underside of the device on the right-hand side of the unit behind the LCD screen.
Other Issues	Please refer to the Troubleshooting section of the <i>N2KView® User's Manual</i> .

If these steps do not solve your problem, please contact Maretron Technical Support (refer to Section 8 for contact information).

Warning: There are no user-serviceable components inside the Maretron TSM800. Opening the TSM800 will expose the sensitive electronic components to adverse environmental conditions that may render the unit inoperative. Please do not open the TSM800, as this will automatically void the warranty. If service is required, please return the unit to an authorized Maretron service location.

6 Mechanical Drawings

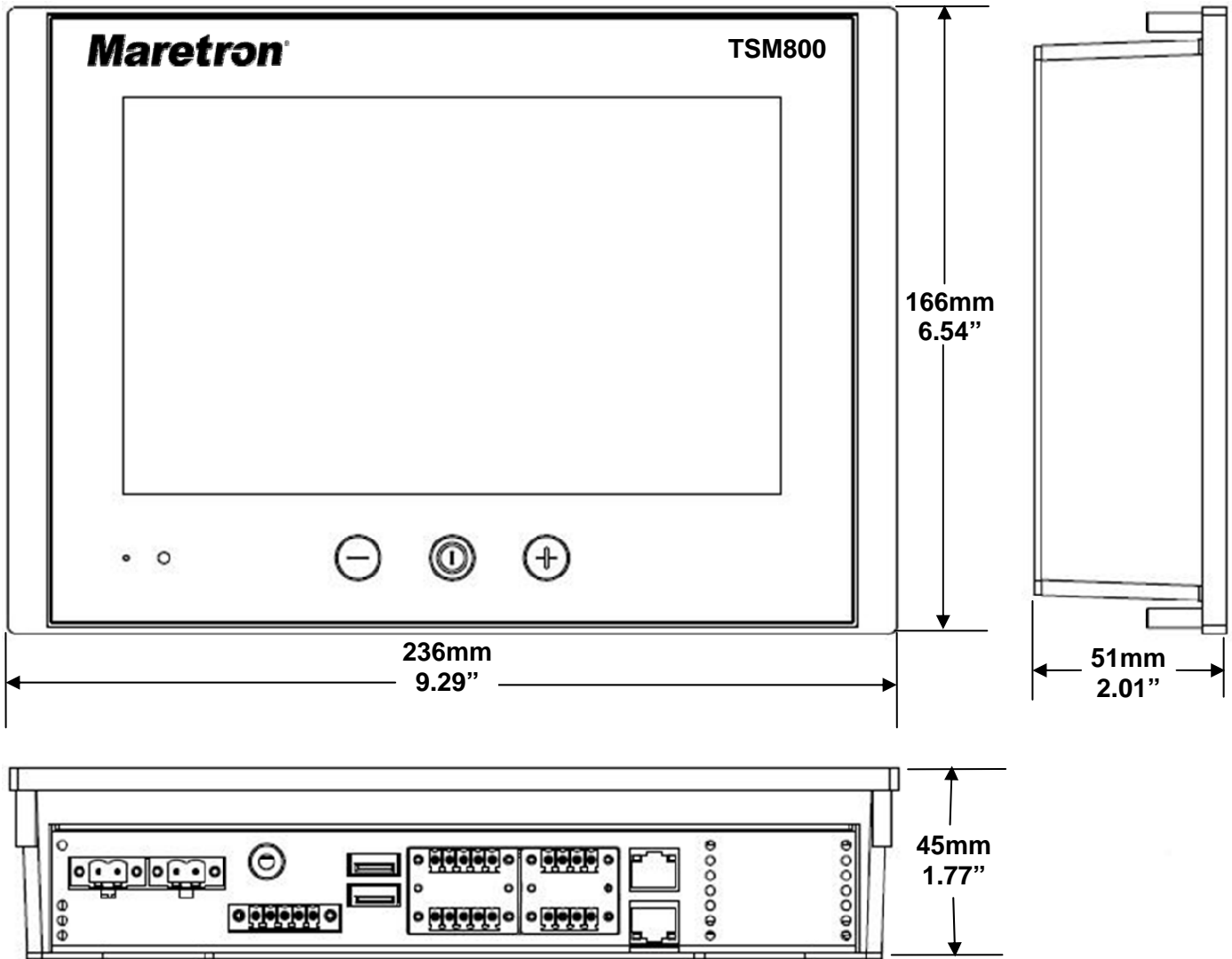

7 Technical Specifications

Specifications

Parameter	Value	Comment
Display Size	8"	LED Backlit LCD with Projected Capacitive Touch Screen
Display Resolution	800x480	WVGA
Display Brightness	600cd/m ²	Optically Bonded
Contrast Ratio	600:1	
LCD Color	262K	
Viewing Angle	70° H, 60° V	
Buzzer	85dB	
USB Ports	Two USB 2.0	
Ethernet Ports	One RJ-45 GbE	For connection to Maretron IPG100 or router
Compass Safe Distance	45cm	Standard
	25cm	Steering

Approvals

Parameter	Comment
IEC 60945	
GL – Germanischer Lloyd	
BV –Bureau Veritas	
IACS E10	
DNV - Det Norske Veritas	
LRS – Lloyd's Register of Shipping	
ClassNK – Nippon Kaiji Kyoaki	
ABS – American Bureau of Shipping	

Electrical

Parameter	Value	Comment
Operating Voltage	18-32 Volts	DC Voltage, Dual Inputs
Power Consumption	20 Watts	Typical
	30 Watts	Maximum

Mechanical

Parameter	Value	Comment
Overall Dimensions (DxWxH)	2.01" x 9.29" x 6.54" (51mm x 236mm x 166mm)	
Weight	4.2 lbs (1.9kg)	
Front Panel Material	Glass	
Front Panel Controls	Power, Brightness +/-	
Mounting	4 x M4 VESA mounting 75mm x 75mm	Max 8mm deep
	Built-in console Mounting	4 x M5 x 15mm screws

Environmental

Parameter	Value
Operating Temperature	-15°C to 55°C (Humidity up to 95%)
Storage Temperature	-20°C to 60°C (Humidity up to 95%)
IP Rating	IP66 Front, IP22 Rear (EN60529)

8 Technical Support

If you require technical support for Maretron products, you can reach us in any of the following ways:

Telephone: 1-866-550-9100
Fax: 1-602-861-1777
E-mail: support@maretron.com
World Wide Web: <http://www.maretron.com>
Mail: Maretron, LLP
Attn: Technical Support
9014 N. 23rd Ave Suite 10
Phoenix, AZ 85021 USA

9 Maretron (1 Year) Limited Warranty

Maretron warrants the TSM800 to be free from defects in materials and workmanship for one (1) year from the date of original purchase. If within the applicable period any such products shall be proved to Maretron's satisfaction to fail to meet the above limited warranty, such products shall be repaired or replaced at Maretron's option. Purchaser's exclusive remedy and Maretron's sole obligation hereunder, provided product is returned pursuant to the return requirements below, shall be limited to the repair or replacement, at Maretron's option, of any product not meeting the above limited warranty and which is returned to Maretron; or if Maretron is unable to deliver a replacement that is free from defects in materials or workmanship, Purchaser's payment for such product will be refunded. Maretron assumes no liability whatsoever for expenses of removing any defective product or part or for installing the repaired product or part or a replacement therefore or for any loss or damage to equipment in connection with which Maretron's products or parts shall be used. With respect to products not manufactured by Maretron, Maretron's warranty obligation shall in all respects conform to and be limited to the warranty actually extended to Maretron by its supplier. The foregoing warranties shall not apply with respect to products subjected to negligence, misuse, misapplication, accident, damages by circumstances beyond Maretron's control, to improper installation, operation, maintenance, or storage, or to other than normal use or service.

THE FOREGOING WARRANTIES ARE EXPRESSLY IN LIEU OF AND EXCLUDES ALL OTHER EXPRESS OR IMPLIED WARRANTIES, INCLUDING BUT NOT LIMITED TO THE IMPLIED WARRANTIES OF MERCHANTABILITY AND OF FITNESS FOR A PARTICULAR PURPOSE.

Statements made by any person, including representatives of Maretron, which are inconsistent or in conflict with the terms of this Limited Warranty, shall not be binding upon Maretron unless reduced to writing and approved by an officer of Maretron.

IN NO CASE WILL MARETRON BE LIABLE FOR INCIDENTAL OR CONSEQUENTIAL DAMAGES, DAMAGES FOR LOSS OF USE, LOSS OF ANTICIPATED PROFITS OR SAVINGS, OR ANY OTHER LOSS INCURRED BECAUSE OF INTERRUPTION OF SERVICE. IN NO EVENT SHALL MARETRON'S AGGREGATE LIABILITY EXCEED THE PURCHASE PRICE OF THE PRODUCT(S) INVOLVED. MARETRON SHALL NOT BE SUBJECT TO ANY OTHER OBLIGATIONS OR LIABILITIES, WHETHER ARISING OUT OF BREACH OF CONTRACT OR WARRANTY, TORT (INCLUDING NEGLIGENCE), OR OTHER THEORIES OF LAW WITH RESPECT TO PRODUCTS SOLD OR SERVICES RENDERED BY MARETRON, OR ANY UNDERTAKINGS, ACTS OR OMISSIONS RELATING THERETO.

Maretron does not warrant that the functions contained in any software programs or products will meet purchaser's requirements or that the operation of the software programs or products will be uninterrupted or error free. Purchaser assumes responsibility for the selection of the software programs or products to achieve the intended results, and for the installation, use and results obtained from said programs or products. No specifications, samples, descriptions, or illustrations provided Maretron to Purchaser, whether directly, in trade literature, brochures or other documentation shall be construed as warranties of any kind, and any failure to conform with such specifications, samples, descriptions, or illustrations shall not constitute any breach of Maretron's limited warranty.

Warranty Return Procedure:

To apply for warranty claims, contact Maretron or one of its dealers to describe the problem and determine the appropriate course of action. If a return is necessary, place the product in its original packaging together with proof of purchase and send to an Authorized Maretron Service Location. You are responsible for all shipping and insurance charges. Maretron will return the replaced or repaired product with all shipping and handling prepaid except for requests requiring expedited shipping (i.e. overnight shipments). Failure to follow this warranty return procedure could result in the product's warranty becoming null and void.

Maretron reserves the right to modify or replace, at its sole discretion, without prior notification, the warranty listed above. To obtain a copy of the then current warranty policy, please go to the following web page:

<http://www.maretron.com/company/warranty.php>