



Toll Free: 1-800-579-8088 Web: www.zinko.com

MODEL

ZASJ-15M ZASJ-30M ZASJ-100M
ZASJ-20M ZASJ-50M

Hydraulic Air Service Jacks

Operating Instructions & Repair Parts List

Operation

The owner and/or operator shall have an understanding of these operating instructions and warnings before operating the jack. Warning information shall be emphasized and understood. If the operator is not fluent in English, the instructions and warning shall be read to and discussed with the operator in the operator's native language by the purchaser/ owner, making sure that the operator comprehends its contents.

Safety Information

Read and follow all WARNINGS, CAUTIONS and INSTRUCTIONS included with each product to use the product correctly and to avoid personal injury or property damage during system operation. ZINKO can not be held responsible for damage or injury resulting from unsafe use of products, lack of maintenance or incorrect system application.

Caution Remarks Used In This Manual

⚠ DANGER Wrong operation is highly likely to result in the operator's death or serious injury.

⚠ WARNING Wrong operation may result in the operator's death or serious injury.

⚠ CAUTION Wrong operation may result in the operator's injury or property damages.

Intended Use

This jack has a lifting feature which utilizes compressed air from an air compressor and is used to lift or lower passenger cars, trucks, or other vehicles. Always **support a lifted load on rigid racks**. This jack may not be used to keep a vehicle at a raised position for car washing.

Danger and Warning Information

Failure to read the danger, warning, and caution information may lead to a vehicle fall, injuries, and/or death(s). Use the jack properly after having fully understood the information.

⚠ WARNING

For Your Safety and to Prevent Injury

1. Read this operation manual thoroughly and fully understand its contents before using the jack. The manual explains important warning information. Follow the warning information, or operation may result in a serious accident.
2. Only the person familiar with the jack operation shall use this jack. Wrong operation may result in an unexpected accident.
3. Use only genuine attachments. Using third party attachments may result in loss of supports due to the lifting vibration, which may result in a vehicle fall.
4. **DO NOT USE THE JACK ON A SLOPE OR SOFT SURFACE.** If a jack is used on a slope or soft surface it may tilt, making the saddle lose engagement with the vehicle, which may result in serious damages due to a vehicle fall.
5. **DO NOT USE THE JACK ON A VEHICLE WITH A BRAKE OR TIRE STOPPER APPLIED.** Doing so may cause the saddle to lose engagement with the vehicle during lifting or operation, which may result in a vehicle fall.
6. **ALWAYS USE RIGID RACKS.** Working on a vehicle supported only by a jack may result in death(s) or serious injuries if the saddle of the jack loses engagement with the vehicle.

⚠ CAUTION

General Cautions

1. Never touch safety valve.
2. Never use this jack for use other than vehicle maintenance.
3. Do not overload this jack beyond its rated capacity.
4. Do not use two or more jack simultaneously.
5. Do not move a vehicle while it's at a jacked up position.
6. Stop using the jack when it squeaks.

Preliminary Cautions

1. Inspect jack before use.
2. Do not use compressed air pressure greater or equal to 0.97 Mpa (9.9 kg f/cm²).
3. No person or object should remain in a vehicle being jacked.
4. Do not use the jack on a vehicle with the engine on.
5. Put a car in neutral gear before using the jack.

Zinko Hydraulic Jack

Models: ZASJ Series

Operational Cautions

1. Ensure saddle is securely engaged at jacking point.
2. Center load on saddle.
3. Ensure area around the jack is cleared before lowering.

Label Affixing Positions and Label Descriptions

ZASJ-15M

- 1) Capacity and model indication label.
- 2) Caution label.
- 3) Safety valve indication label.
- 4) Oil adding label.
- 5) Warning label.
- 6) Lubrication label.

ZASJ-20M

- 1) Capacity and model indication label.
- 2) Caution label.
- 3) Safety valve/oil adding label.
- 4) Warning label.
- 5) Lubrication label.

ZASJ-30M, ZASJ-50M, & ZASJ-100M

- 1) Capacity and model indication label.
- 2) Caution label.
- 3) Oil adding label.
- 4) Safety valve indication label.
- 5) Warning label.
- 6) Lubrication label.

CAUTION Handle affixed labels carefully. If labels come off or get stained, purchase replacements from your dealer and affix them at proper positions.

Structure and Part Descriptions

How To Install the Handle

Before using jack, assemble handle as follows:

Model: ZASJ-15M

1. Insert handle securely deep into the end.
Tightening Torque: 50-75 N·m (500-750 Kgf·cm) (the tightening torque corresponds to tightening with 25-37.5 kg force using a spanner 20 cm in length).
2. Fasten with bolt nut (use either nominal size 17 spanner or box wrench).
Tightening Torque: 7-8 N·m (70-80 Kgf·cm) (the tightening torque corresponds to tightening with 3.5-4 kg force using a spanner 10 cm in length).
3. Screw air hose into the hose joint (use nominal size 16 spanner).
Tightening Torque: 7-8 N·m (70-80 Kgf·cm) (the tightening torque corresponds to tightening with 3.5-4 kg force using a spanner 10 cm in length).

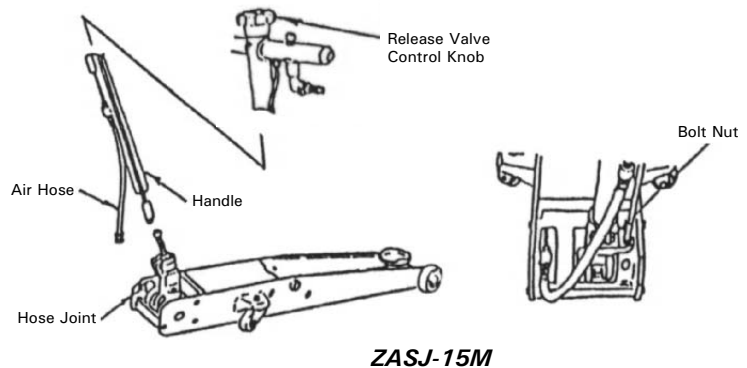

ZASJ-15M

* After installation and before using the jack, check to ensure smooth turning of release valve control knob (make sure by pumping the handle a few times), secure installation of the handle, and check that the hose joint is not loose, and that the hose is not twisted.

Model: ZASJ-20M

1. Remove bolt and insert handle. Insert handle deep to the end.
Tightening Torque: 35-60 N·m (350-600 Kgf·cm) (the tightening torque corresponds to tightening with 17.5-30 kg force using a spanner 20 cm in length).
2. Tighten Bolt (use either nominal size 19 spanner or box wrench).
Screw bolt into hole and tighten bolt.
Tightening Torque: 7-8 N·m (70-80 Kgf·cm) (the tightening torque corresponds to tightening with 3.5-4 kg force using a spanner 10 cm in length).
3. Screw air hose into the hose joint (use nominal size 16 spanner).
Tightening Torque: 7-8 N·m (70-80 Kgf·cm) (the tightening torque corresponds to tightening with 3.5-4 kg force using a spanner 10 cm in length).

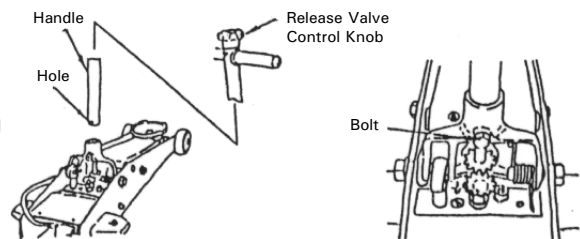

ZASJ-20M

* After installation, ensure smooth turning of release valve control knob and secure installation of the handle before using the jack.

Models: ZASJ-30M, ZASJ-50M, & ZASJ-100M

1. Insert handle securely deep into the end.
Tightening Torque: 50-75 N·m (500-750Kgf·cm) (the tightening torque corresponds to tightening with 25-37.5 kg force using a spanner 20 cm in length).
2. Fasten with bolt nut (use either nominal size 17 spanner or box wrench).
Tightening Torque: 50-75 N·m (500-750Kgf·cm) (the tightening torque corresponds to tightening with 25-37.5 kg force using a spanner 20 cm in length).

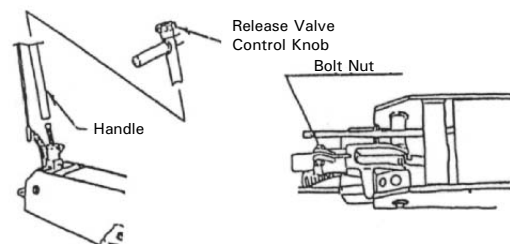

ZASJ-30M, ZASJ-50M,
& ZASJ-100M

* After installation, ensure smooth turning of release valve control knob and secure installation of the handle before using the jack.

Zinko Hydraulic Jack

Models: ZASJ Series

ZASJ-15M

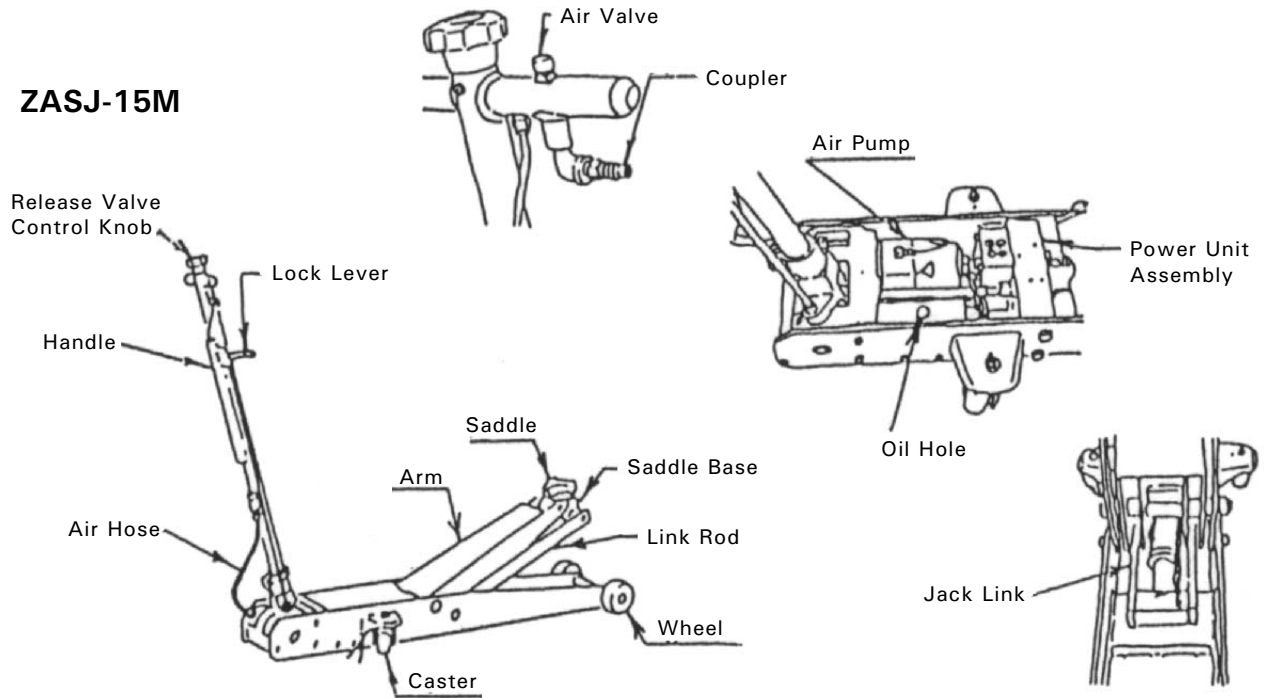

ZASJ-20M

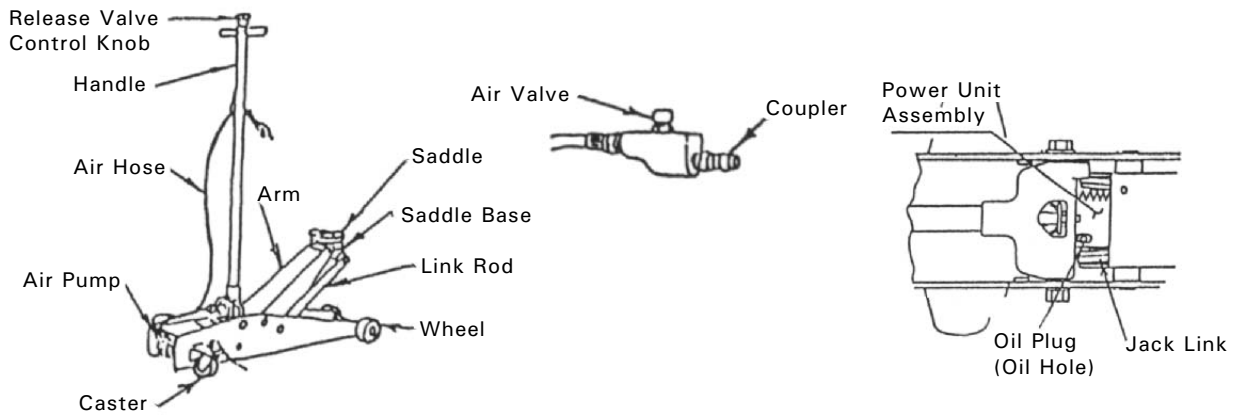

ZASJ-30M, ZASJ-50M, & ZASJ-100M

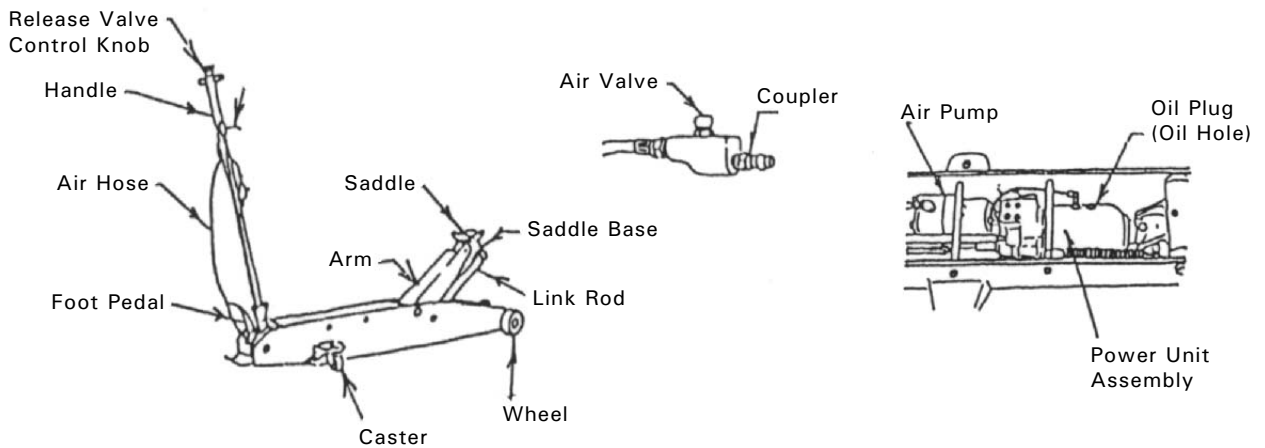

Zinko Hydraulic Jack

Models: ZASJ Series

Air Coupler

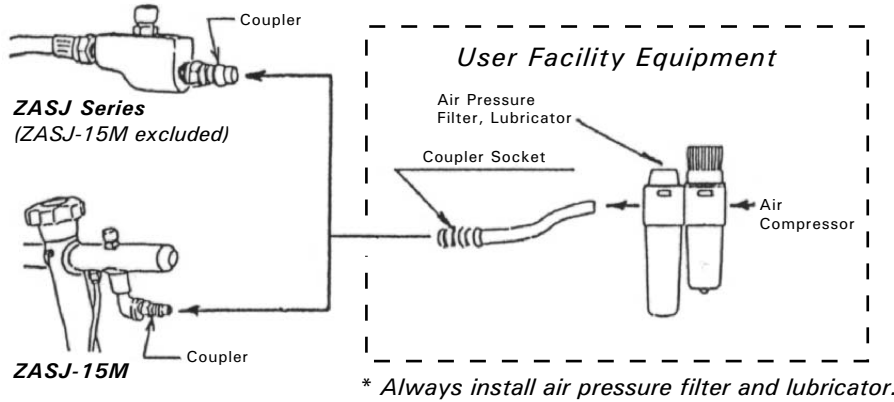

CAUTION Only use correctly sized, manufactured, and rated couplers with ZASJ series jacks. Using other couplers may result in accidents. When using another coupler (socket), replace the existing coupler (plug) with the one matching the coupler socket. **Before connecting coupler, remove dirt and soil from it. Use coupler properly after having thoroughly read and understood its operation manual.**

How to Replace Coupler (Plug)

Loosen and remove coupler (plug), and fasten replacement coupler (plug). NOTE: Fastening torque should be the torque designated by the manufacturer of the coupler.

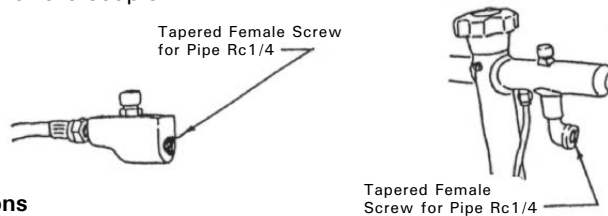

Operation Instructions & Cautions

Compressed Air Use

Regarding compressed air from compressor (called air hereafter) to be used to operate jack.

1. Air pipe from air compressor to the jack should be as short as possible. A long pipe lowers air pressure, cutting down jack's lifting/lowering ability.
2. Always install air pressure filter and lubricator at the pipe end on the air compressor side to use air supplied with clean lubricating oil. Entering dust, moisture, and others into the system, or insufficient lubrication may cause failure.

CAUTION Pressure of the air for use with jack operation should be equal to, or under 0.97 Mpa (9.9 kg f/cm²). Using higher air pressure air may result in damages to the jack and/or a serious accident.

NOTE: Using air not supplied with lubricating oil causes air pump failure. Make sure to use air supplied with lubricating oil. If lubricator is not installed, supply 3-5 drops of clean lubricating oil (ISO VG 10-32) from coupler (plug) once a day.

Preliminary Inspection

Be sure to inspect jack daily before use. Inspection should be performed without any load.

CAUTION If anything abnormal is found on jack, contact your dealer. **DO NOT USE THE JACK UNTIL IT IS COMPLETELY REPAIRED.** Using the jack without repair may result in damages to the jack and/or a serious accident.

* Refer to *Part Description* on pages 2 and 3.

Where to Inspect	What to Inspect	How to Inspect
Air Supplied	Is air pressure equal to or under 0.97 Mpa (9.9 kgf/cm)?	Use pressure gauge.
	Is air clean?	Inspect filter.
	Is lubricating oil being supplied?	Inspect lubricator.
Saddle	Any deformation, damage, or abrasion?	Visual inspection.
Arm, Saddle Base, Link Rod and Jack Link	Any deformation, damage, or abrasion?	Visual inspection, and inspection upon pumping up to full height and down.
Front Wheels & Rear Wheels	Do they turn smoothly? Any deformation, damage, or abrasion?	Visual inspection and inspection upon moving.
Arm Section & Jack Section	Do they move smoothly without any noise when lifting and lowering?	Visual and hearing inspection.
Around Jack Section	Any oil leakage?	Visual inspection.

Zinko Hydraulic Jack

Model: ZASJ Series

Every Screw Section (bolts and nuts)	Any deformation, damage, or loosening?	Visual inspection, and inspection using a spanner and such.
Snap Ring, Cotter Pin, and Such	Any deformation, damage, or coming off?	Visual inspection.
Air Hose	Any deformation, damage, cracking, or coming off?	Visual inspection.
Air Bulb	Any deformation, damage, or loosening?	Visual inspection, and inspection using a spanner and such.
Air Pump	Is operation sound rhythmical?	Hearing inspection.

⚠ WARNING

Surface Condition to Operate Jack

- DO NOT use jack on a slope or soft surface. Doing so tilts the jack causing the saddle to lose engagement with the load, which may result in death(s) or serious injuries due to a vehicle fall. A slope causes a vehicle to roll, which may result in a serious accident. ALWAYS USE THE JACK ON A HARD LEVEL SURFACE.

Jacking Point and Jack Direction

- When supporting a vehicle, do it at garage jacking point (called jacking point hereafter) designated by the manufacturer of the vehicle, never at other points. Failure to heed this warning may result in a serious accident due to deformation of the vehicle or unbalanced load.
- Make sure to center the load on saddle at jacking point.
- Align vehicle tires straight ahead by turning vehicle's steering wheel.
- Position the jack perpendicularly to the vehicle. Diagonal positioning of the jack causes saddle to lose engagement with the vehicle, which may result in a vehicle fall, injuries, and/or death.



Raising and Sustaining Load

Raising Saddle

The capacity in the specifications means lifting load at the point where saddle is raised to the middle height of the lifting range. When the height of the saddle is lower than the middle height of the lifting range, the capacity becomes smaller.

ZASJ-15M

Air Operation: Close bulb by turning release valve control knob clockwise, then press air bulb.

Manual Operation: Close bulb by turning release valve control knob clockwise. Pull up lock lever and fix it by turning right, then pump handle.

ZASJ-20M

Air Operation: Close bulb by turning release valve control knob clockwise, then press air bulb.

Manual Operation: Close bulb by turning release valve control knob clockwise, then pump handle.

ZASJ-30M, ZASJ-50M & ZASJ-100M

Air Operation: Close bulb by turning release valve control knob clockwise, then press air bulb.

Manual Operation: Close bulb by turning release valve control knob clockwise. Pull up lock lever and fix it by turning right, then pump handle. Without any load, pumping foot pedal helps saddle to rise quickly.

⚠ CAUTION

- Keep your eyes on the system during operation. Looking aside may result in a serious accident.
- DO NOT use jack on a vehicle exceeding the jack's capacity, as doing so may result in damages to the jack.

Sustaining Saddle

Saddle stops rising when air bulb is released, or handle pumping is stopped. Saddle maintains the load at the stopped position.

⚠ DANGER

NEVER WORK UNDER A VEHICLE SUPPORTED ONLY BY A JACK. Doing so may result in death(s) or serious injuries. Always support vehicle with rigid racks when working under a vehicle.

⚠ CAUTION

- At the point when raised saddle contacts the vehicle, stop lifting to ensure saddle is engaging at the proper jacking point. If it is off the point, lower saddle, and adjust it to the proper jacking point.
- GRIP HANDLE FIRMLY WHEN PUMPING. When something goes wrong with jack, its handle sometimes sprigs up or pumping gets spongy, which may result in injuries. Always grip handle firmly when operating. If something is found with the jack, lower the vehicle, and DO NOT USE THE JACK UNTIL IT IS FULLY REPAIRED. Contact your dealer immediately.

Zinko Hydraulic Jack

Models: ZASJ Series

Lifting Range Limitation (applies to all models)

When reaching full lift, lifting range limitations activates, so pressing air bulb or continuing handle pumping does not lift any more.

CAUTION DO NOT LIFT A VEHICLE UNNECESSARILY HIGH. Lift a vehicle to the minimum height where it can be supported by rigid rack(s). A vehicle lifted unnecessarily high is not only difficult for you to position rigid racks for support, but also may result in a vehicle fall, injuries, and/or death(s).

How to Place or Remove Rigid Racks

- CAUTION**
- 1) Read and understand thoroughly the operation manual of rigid rack(s) before using it.
 - 2) Support vehicle at rigid rack points designated by the manufacturer of the vehicle. NEVER SUPPORT THE VEHICLE AT ANY POINT OTHER THAN THESE POINTS.
 - 3) Make the left and the right rigid rack a uniform height.
 - 4) DO NOT overload rigid racks with a vehicle exceeding the rack's capacity.

Cautions for Placing Rigid Racks

When placing rigid racks in both the front and rear of the vehicle, lift the front and the rear alternately for two or three times. Lifting only one end without alternating the two makes the angle of the vehicle and the rigid rack(s) too wide, which may cause saddle to slip, and the rigid rack(s) to fail to support the vehicle. Lowering the jack to load the vehicle onto the rigid rack(s) makes the vehicle move backward a little. Position the rigid rack(s), taking into account how much the vehicle moves backward.

- WARNING**
- 1) DO NOT LIFT OR LOWER A VEHICLE MORE THAN 200mm ALL AT ONCE. Doing so makes the angle formed by the rigid rack(s) and the vehicle so wide that the rigid rack(s) may topple over.
 - 2) When removing rigid racks, use the jack with the same capacity as that of the rack. Failure to heed this warning may result in damages to the jack and/or a serious accident.

Cautions for Removing Rigid Racks

Remove rigid racks reversing the procedures for placing the racks. Be sure to lower the front and rear of the vehicle alternately for two or three times.

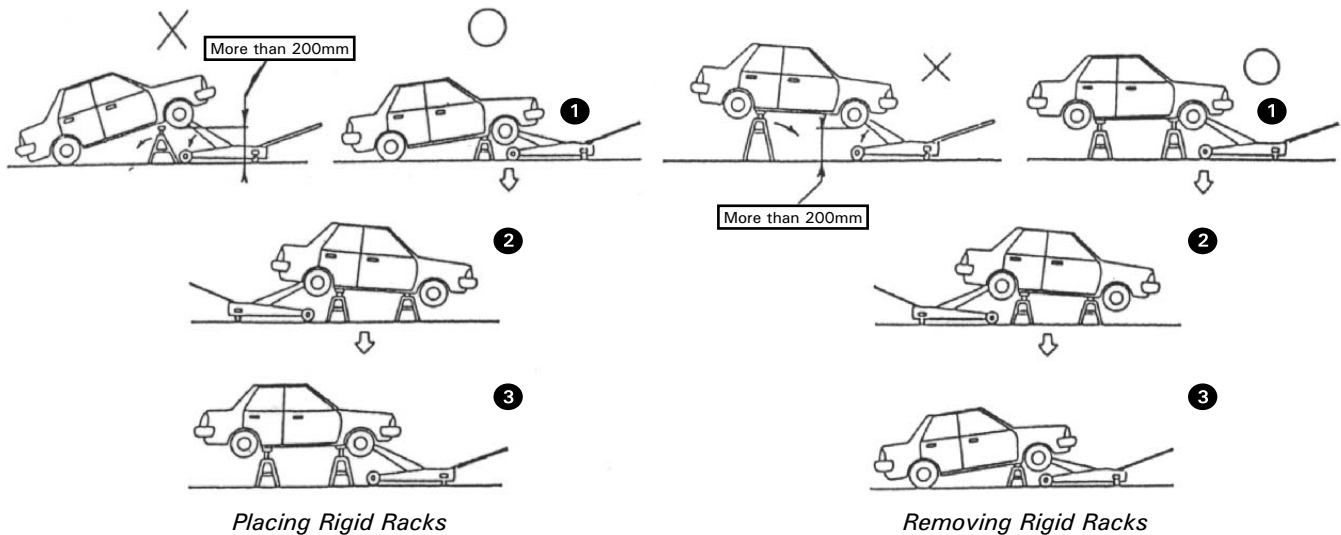

Lowering Operation (Applies to All Models)

Slowly lower the vehicle by slowly turning release valve control knob counterclockwise.

DANGER Ensure area around the vehicle is cleared of people and objects when lifting or lowering the vehicle. Not doing so may result in a serious accident.

CAUTION Slowly turn release valve control knob. Quick turning makes the vehicle fall rapidly, which may cause the jack to lose the jacking point, vehicle slide, and/or damages to the jack resulting in a serious accident. MAKE SURE TO LOWER THE VEHICLE SLOWLY.

After Use Inspection

After Use Cleaning and Storage

Wipe off dirt, oil, grease and such from saddle, arm, and frame. If the affixed labels are stained, or the jack appears to be damaged consult your dealer immediately. For safety, lower the arm to its lowest position and store the jack indoors.

- CAUTION**
1. Be sure that jacks with a handle lock feature are stored with the handle locked.
 2. Keep the jack away from human and vehicle traffic.

Zinko Hydraulic Jack

Models: ZASJ Series

Periodical Inspection

The following *Safety Inspection Table* contains very important inspection points to ensure safe everyday jack operation, and long life of the jack. Use this table at periodical inspections, and whenever the jack appears to be in abnormal condition. When jack appears to be in such condition, stop using the jack until it is completely repaired and contact your dealer immediately. To continue using the jack without repair may result in damages to the jack and a serious accident.

Jack Oil To Add and Change

Use the designated jack oil only: hydraulic fluid **ISO VG 10-32**.

CAUTION Never use high viscosity oil, brake fluid, volatile oil, or vegetable oil. Using such oil will cause jack to malfunction.



Safety Inspection Table

When to Inspect	Where to Inspect	Inspection Item	Inspection Method	Maintenance
Prior to Operation	Air Supplied	• Is pressure equal to or below 0.97Mpa (9.0 kgf/cm ²)?	• Measure using a pressure gauge.	• Pressure should be equal to or below the designated pressure.
		• Is air clean?	• Check filter.	• If filter is stained or choked up, clean or replace it.
		• Is lubricating oil supplied?	• Check lubricator.	• If there is not enough lubricating oil, add oil.
	Saddle Arm, Saddle Base, Link Rod, Jack Link, Front & Rear Wheels	• Appearance Check if there is any deformation, damage, or abrasion.	• Visual inspection.	• If it is damaged, considerably deformed, or worn out, consult your dealer.
	Saddle	• Rotation Check if it rotates smoothly.	• Rotate it.	• If it does not rotate smoothly, lubricate it.
	Arm, Saddle Base, Link Rod, Jack Link	• Axes and holes that slide and rotate Check if they spin smoothly, and if they are worn out.	• Raise to full lift without loading a vehicle, and perform hearing and visual inspection.	• If there is any abnormal sound or hitch, lubricate. If the sound continues after the lubrication or the parts are considerably worn out, consult your dealer.
	Front Wheels, Rear Wheels	• Axes and holes that slide and rotate Check if they spin smoothly, and if they are worn out.	• Move the jack without loading a vehicle, and perform hearing and visual inspection.	• If there is any abnormal sound or hitch, lubricate. If the sound continues after the lubrication or the parts are considerably worn out, consult your dealer.
	Jack Section	• Appearance Check if there is any deformation, damage, or abrasion.	• Raise and lower the jack, and perform hearing and visual inspection.	• If it is damaged, considerably deformed, or worn out, is leaking oil, or making abnormal sounds, consult your dealer.
	Every Screw (bolt and nut)	• Check if there is any deformation, damage, or loosening.	• Visual inspection, and check using a spanner and such.	• If loose, tighten it.

Zinko Hydraulic Jack

Models: ZASJ Series

Safety Inspection Table (continued)

Prior to Operation	Snap Ring, Cotter Pin, and such	<ul style="list-style-type: none"> • Check if there is any deformation, damage, or coming off. 	<ul style="list-style-type: none"> • Visual inspection. 	<ul style="list-style-type: none"> • If a part is coming off, reassemble it. • If a part is deformed or damaged, replace it.
	Air Hose	<ul style="list-style-type: none"> • Appearance Check if there is any deformation, damage, cracking, or loosening (coming off). 	<ul style="list-style-type: none"> • Visual inspection and inspection by touching. 	<ul style="list-style-type: none"> • If it is damaged, considerably deformed, or cracking, consult your dealer.
	Air Bulb	<ul style="list-style-type: none"> • Appearance Check if there is any deformation, damage, or air leakage. 	<ul style="list-style-type: none"> • Visual inspection and inspection by touching. 	<ul style="list-style-type: none"> • If it is damaged, considerably deformed, or leaking air, consult your dealer.
	Air Pump	<ul style="list-style-type: none"> • Operation Check if the operating noise is rhythmical. 	<ul style="list-style-type: none"> • Hearing inspection. 	<ul style="list-style-type: none"> • If the operating noise is erratic, consult your dealer.
Once Every Two Weeks	Front Wheels, Rear Wheels	<ul style="list-style-type: none"> • Appearance 	<ul style="list-style-type: none"> • Visual Inspection. <p>Curved Section</p> 	<ul style="list-style-type: none"> • If the curved section is worn out and the outside diameter is leveled, consult your dealer.
	Handle, Foot Pedal	<ul style="list-style-type: none"> • Appearance Check if there is any deformation, damage, or abrasion 	<ul style="list-style-type: none"> • Visual inspection. 	<ul style="list-style-type: none"> • If the curved section is worn out and the outside diameter is leveled, consult your dealer.
	Arm, Saddle Base, Link Rod, Jack Link, Front Wheels, Rear Wheels	<ul style="list-style-type: none"> • Axes and holes that slide and rotate Check if they spin smoothly, and if there is abrasion. 	<ul style="list-style-type: none"> • Raise and lower the system, and perform hearing, visual, and touching inspection. 	<ul style="list-style-type: none"> • If there is any abnormal sound or hitch, lubricate. If the sound continues after the lubrication or the parts are considerably worn out, consult your dealer.
	Jack Link (only applies to ZASJ-15M & ZASJ-20M)	<ul style="list-style-type: none"> • Appearance, axes, and holes Check if there is any deformation, damage, or abrasion. 	<ul style="list-style-type: none"> • Visual inspection and measurement. Raise the system to full lift without loading a vehicle, and measure the height of saddle from the ground surface. 	<ul style="list-style-type: none"> • If there is damage, considerable deformation, or abrasion, and the maximum height is under the figures below, repair the jack link.
		<p><i>Height of saddle from the ground surface</i></p> 	<p>ZASJ-15M = 600mm ZASJ-20M = 470mm</p>	
Once Every Three Months	Jack Section	<ul style="list-style-type: none"> • Check oil level. 	<ul style="list-style-type: none"> • Lower saddle to the lowest position, and check if the oil is filled to oil hole (oil plug for ZASJ-15M) 	<ul style="list-style-type: none"> • Add jack oil if the reservoir oil is insufficient.
Once A Year	Jack Section	<ul style="list-style-type: none"> • Jack oil. 	<ul style="list-style-type: none"> • Visual Inspection. 	<ul style="list-style-type: none"> • Change oil.

Zinko Hydraulic Jack

Models: ZASJ Series

Lubricating Movable Parts

Lubricating Oil: **Machine Oil**

Grease: **Use spray type grease. Lubricate grease nipple with chassis grease.**

Where to Lubricate

Lubricate every sliding and rotating parts once every two weeks. Points indicated with an arrow are very important lubrication points. Make sure to lubricate these points with lubricating oil or grease.

ZASJ-15M

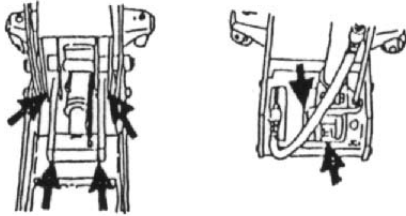

ZASJ-20M

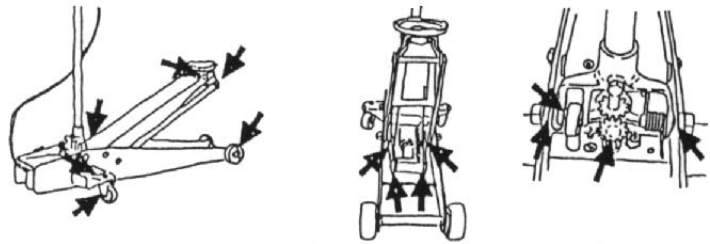

ZASJ-30M, ZASJ-50M, & ZASJ-100M

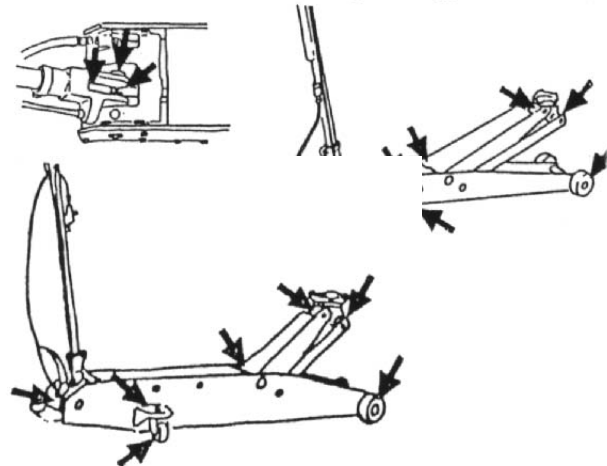
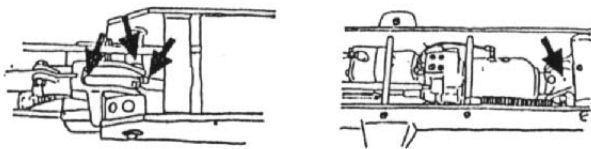

Troubleshooting

Before contacting your dealer for repair, consult this manual and check the points described below. If doing so has not solved your problem, consult your dealer.

When Lifting Manually		
Jack Will Not Advance	Is handle or release valve control knob completely fastened?	Fasten completely.
	Is jack filled with oil?	Add jack oil.
When Lifting By Air		
Jack Will Not Advance	Is air supplied?	Supply air.
	Is air pump working?	Consult your dealer.
	Is release valve control knob completely fastened?	Fasten completely.
	Is jack filled with jack oil?	Add jack oil.
	Air is inside the system.	Bleed the system.
Jack Advances Slowly	Is air pressure low?	Raise the air pressure to the pressure indicated in the specifications.
	Is piping from air compressor long?	Shorten the piping.
When Operating Either By Air or Manually		
Jack Advances, But Stops in the Middle	Insufficient jack oil?	Add jack oil.
	Too much jack oil?	Drain excess jack oil.
Jack Drops Spontaneously	Is handle or release valve control knob completely fastened?	Fasten completely.
Jack Will Not Come Down to the Lowest Position	Is every sliding and rotating part lubricated?	Lubricate.
	Is there too much air in jack reservoir?	Lower saddle to the lowest position, open oil hole, and let the air out.

*If these steps do not solve the problem with jack operation, contact your dealer.

Zinko Hydraulic Jack

Models: ZASJ Series

REV 072607

NOTE 1: When adding jack oil, lower saddle to the lowest position, remove the jack's oil plug, and fill oil up to oil hole. (In the case of ZASJ-15M, fill oil to the oil level indicated on oil plug).

How to Bleed the System

If the jack will not advance even though air pump is operating, it is possible that air is in the hydraulic system. Bleed the system following the instructions below.

1. Open bulb by turning release valve control knob once or twice counterclockwise.
2. Press air bulb to operate air pump for ten seconds. Repeat this two or three times. Now the bleeding operation is complete.
3. Fasten bulb by turning release valve control knob clockwise, and try raising saddle by pressing air bulb.



ZINKO HYDRAULIC JACK

PO Box 4903, Ontario, CA 91761

Toll Free: 1-800-579-8088

<http://www.zinko.com>

Phone: (909)989-9526

Fax: (909)989-1724