

# Neuralynx

High Density Electrophysiology Recording Systems

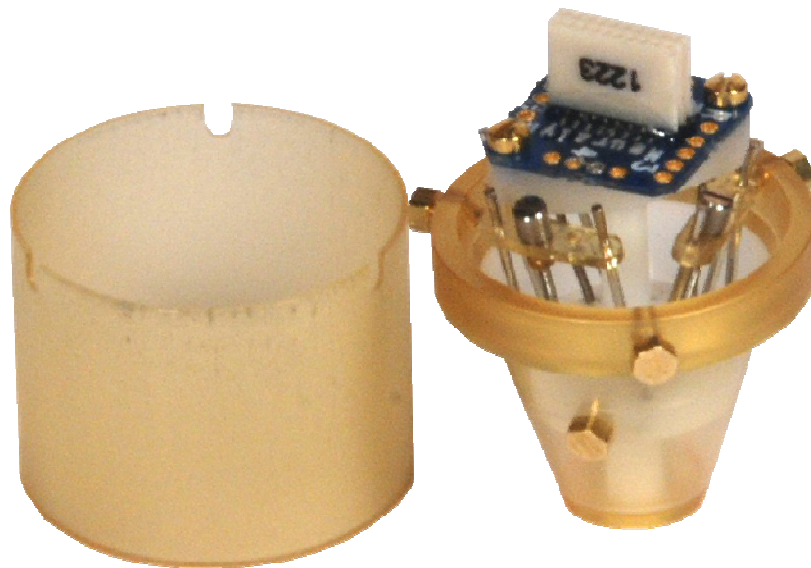

## Harlan 4 Drive User Manual

**Microdrive used for manually driving tetrodes for  
electrophysiology recordings**

Revision 1.1  
7/2/2013

© Neuralynx, Inc.  
105 Commercial Drive, Bozeman, MT 59715  
Phone 406.585.4542 • Fax 866.585.1743  
[www.Neuralynx.com](http://www.Neuralynx.com)  
[support@Neuralynx.com](mailto:support@Neuralynx.com)

## Table of Contents

1	Document Overview .....	3
2	Harlan 4 Drive Overview .....	3
3	Glossary .....	4
4	Drive Specifications .....	5
5	Drive Preparation .....	6
6	Microdrive Implantation .....	10
7	Recycling the Microdrive .....	11
8	Appendix B – Microdrive Parts Identifier .....	15

## List of Figures and Tables

Figure 5.1	Initial Telescoping Tube Assembly .....	7
Figure 5.2	Final Telescoping Tube Assembly .....	7
Figure 5.3	Drive Assembly .....	8
Figure 10.1	Microdrive Parts Identifier .....	15
Figure 10.2	Neuralynx's EIB-16 and EIB-18.....	15

# 1 Document Overview

The purpose of this manual is to outline assembly, loading, and general implantation of the Harlan 4 microdrive. It also describes the appropriate preparation and recycling procedures surrounding the experiment.

Step-by-step instructions are outlined and additional products like the Drive Assembly Fixture are recommended to further facilitate this process.

## 2 Harlan 4 Drive Overview

The Harlan 4 Drive is a 4-tetrode microdrive that allows for recordings from a single brain structure or from two or more structures that fall on one line that extends from the skull surface into the depths of the brain.

For initial drive preparation, assemblies of telescoping polyamide tubes must be built and attached to the microdrive. The Drive Assembly Fixture aids with loading and the tube assemblies are inserted into the drive plate and bonded with an adhesive. The tetrodes are fed through the guide tubes and the assembly is inserted with drive screws into the cone. The tetrodes are gold-plated, the cone components are assembled, and the drive is ready for experimentation.

A general implantation outline is provided, but there will be variations according to particular animals and objectives of the research to be accomplished.

After experimentation, recycling guidelines describe how the drive can be reused on other animals with a new replaceable tip and new polyamide tube assemblies.

Ray Harlan is the maker of this drive and can be contacted at:

Specialty Machining  
15 Happy Hollow Road  
Wayland, MA 01778  
Phone and FAX (508) 358-4013  
[rbharlan@comcast.net](mailto:rbharlan@comcast.net)

### **3 Glossary**

*Inner Diameter (ID)* – the inner diameter of the polyamide tubing

*Outer Diameter (OD)* – the outer diameter of the polyamide tubing

*EIB* – Electrode Interface Board

## 4 Drive Specifications

Travel for each drive	7.9 mm
Travel for each revolution of the drive screw	160 micrometers
Height of microdrive	28.4 mm
Diameter of microdrive	18.9 mm
Weight	
Without Cover	2.1 grams
With Cover	2.6 grams

## 5 Drive Preparation

Before the microdrive can be used, assemblies of telescoping polyamide tubes must be built and attached to the microdrive. These tubes provide the rigidity needed to precisely deliver the tetrode tips to the intended locations. For each drive, one tube is attached to a guide tube in the tip. Three other tubes are telescoped together and attached to the drive plate. After the drive is installed in the microdrive, the tetrode is inserted in the innermost tube and bonded to it.

Four or more sizes of polyamide tubing are used in the microdrive. The exact sizes and wall thickness may not always be available from tubing vendors. There is some flexibility in choosing sizes; it is best to try to get wall thickness specified here and adjust diameters as needed. Try to provide .001-.003 in. diametral clearance between telescoping pairs of tubes. The recommended sizes, from smallest to largest, are:

.0056" OD, .0035" ID, .001" wall

.10 " OD, .008" ID, .001" wall

.012" OD, .0065" ID, .0028" wall

.0196" OD, .0135" ID, .0030" wall

Guide tubes for the tip should be approximately .046" OD to fit the tip hole. The ID needs to be at least .031".

The following steps will ensure properly working drives. Careful attention paid to tube lengths and assembly geometry will make the job of installing the drives easier.

1. Loosen the cover screws and remove the cover of the microdrive. Remove the body screws from the cone and remove the body. Store the small screws in a secure place. Remove all of the drives.
2. Cut one piece of each size of tubing for each drive to be assembled. Use a new single or double-edged razor blade to avoid crushing the tubing. Cut the following lengths:
  - a. 12.5 mm of .0056" OD
  - b. 15 mm of .010" OD
  - c. 2 mm of .012" OD
  - d. 10.5 mm of .0196" OD

The .012” tube is used as a spacer between the .0056” and .0196” tubes. The thicker wall helps center the small tube. The .010” tubing can be used instead, if a small quantity of the .012” tubing cannot be obtained (ask for a sample one-foot piece, which will make 150 assemblies).

3. Slide the 2-mm length .012” tube over the .0056” tube so that ½ mm of the small tube extends past the end of the .012” tube. Bond these together with a thin or gap-filling Cyanocrylate adhesive, such as Zap or Zap-A-Gap. Use the point of a straight pin, needle or a flat-tip oiler (black) to apply the tiniest drop of adhesive and then use some accelerator if the bond does not set quickly. Be very careful not to get any adhesive inside the smaller tube. The thinner adhesive seems to do a cleaner job. Cut cured adhesive off the applicator frequently.



**Figure 5.1 Initial Telescoping Tube Assembly**

4. Insert this assembly, .0056” tube first, into the .0196” tube until ½ mm of the .012” tube extends past the end of the large tube. Bond this assembly together as in Step 4, again being careful not to get adhesive in the small tube. Note that the .0056” tube extends about 1 mm past the bottom end of the .0196” tube. This helps when inserting it into the .010” tube in the drive. The top of the assembly should look like a stepped cone, with both .012” and .0056” tubes extending equal amounts from their next larger tubes.



**Figure 5.2 Final Telescoping Tube Assembly**

5. Insert the drive screw into the Drive Assembly Fixture hole furthest from the top end of the fixture. Push it in until the retaining nut seats against the fixture. Insert the tube assembly into a drive plate and assembly fixture until the .0056” tube at the bonded-end extends 2mm past the top surface of the plate. Bond the assembly to the plate with Cyanocrylate adhesive. If a gel-type adhesive is used, it is possible to just put a tiny fillet between the tube and drive plate and not have it wick down the hole. This will facilitate removing the tube to recycle the microdrive. Accelerator must be applied to achieve curing. A small bottle that has a Luer top that can take a hypodermic needle is ideal for applying just a tiny drop onto the glue. Try not to touch the needle to the glue; it can get

clogged. Use a 26-gauge or finer needle, hold the bottle inverted and just let gravity form a drop on the tip of the needle.

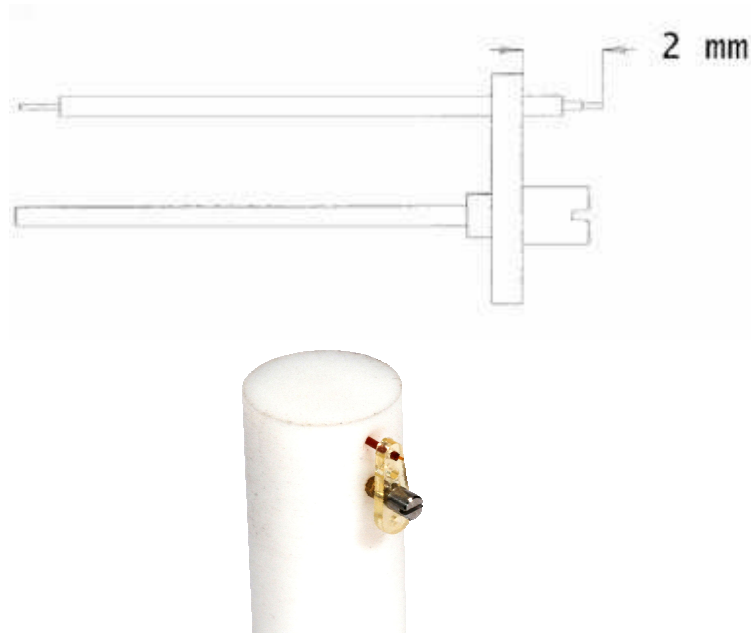

**Figure 5.3 Drive Assembly**

6. Cut the tip guide tube to 5 mm long. Insert it into the tip of the body. It should extend exactly 2 mm beyond the end of the tip. Bond it in place with a small dab of gel-type Cyanocrylate adhesive.
7. Insert the intermediate tubes (.010" OD) into the inner holes in the body. Push them through until they exit the tip. When all tubes are in place, push them further until all are about ½ mm above the top surface of the body. Bond them to the guide tube with low-viscosity Cyanocrylate adhesive. Then cut the tubes off flush with the guide tubes.
8. Place a drive over the guide pins so the pins enter the holes in the drive plate. Slide the drive down until the smallest tube almost touches the intermediate .010" tube. Guide the small tube into the .010" tube as the drive is moved further downward. The drive screw now can be engaged in the body threads to move the drive. Guide the outer tube over the .010" tube as the drive is advanced.
9. When all the tubes are telescoped, test the freedom of the assembly by advancing the drive over the full travel range (7.9 mm). Add the other drives and test their travel. If there is any binding, remove the drive and check that a separate piece of .010" tubing can be slid into the drive tube assembly up to the drive plate. If excess Cyanocrylate has been used, it may have wicked between the tubes and bonded them together. If so, replace the tube assembly with another. If the outer tube does not pull out of the drive plate fairly easily, soaking the tip of the drive plate in water for a few hours should soften the



Cyanocrylate. Try to keep the screw out of water.

10. Make up the tetrodes according to your standard procedure. Back off the drives until the heads of the drive screws are just below the ends of the guide pins. This should keep the outer tubes in the body holes. Insert the tetrodes into the inner tubes and slide them through until they are just flush with the tip guide tubes. Bond them with Cyanocrylate adhesive to the tops of the inner tubes.
11. Cut the tetrodes at 12 mm above the ends of the inner tubes. Separate about 6 mm of the wires and feed them into their respective recording channel holes on the connector board. The end of each wire should extend about 2 mm above the top of the board. Insert a cactus needle into each hole from the top of the board and push firmly to ensure contact of the wire with the circuit trace. Break off the excess cactus needle. Break off excess tetrode wire with forceps.
12. After all the wires have been connected, dress them away from the guide pins so there is no chance of binding or snagging as the drives are advanced.
13. Cut a piece of insulated tungsten ground wire approximately 150 mm long. Strip the insulation off both ends. Feed the wire into the ground-wire hole in the body from below. This hole will be located between two drives near the outer periphery of the body and near the rear of the drive. Slide the wire through until the end can be inserted into the ground hole on the connector board. Secure it with a cactus needle and break off excess needle.
14. Feed the ground wire into the ground hole in the lower part of the cone. Reassemble the cone to the body, aligning the ground holes in the body and cone (one above the other). Pull the wire through, leaving sufficient slack so that the wire won't snag on a drive. Solder a lug, fashioned from copper-tin foil to make good contact with the ground screw. The excess wire can be wrapped around the lower cone and taped in place temporarily with small bits of Scotch tape.
15. Gold plate the tetrodes using your standard protocol.
16. Retract the tetrodes by backing out the drive screws until they are just free of the body. Seal the intermediate tubes by touching the end of the guide tubes to a light mineral oil. Blot off excess oil with an absorbent wiper. The microdrive now is ready for implantation.

## 6 Microdrive Implantation

The following outline is meant to be a general guide to implanting the microdrive. There will be variations according to particular animals and objectives of the research to be accomplished.

1. Shave head area around location of incision.
2. Secure anaesthetized animal in stereotactic fixture.
3. Make incision and hold skin apart with appropriate clamps.
4. Scrape away tissue over the skull.
5. Attenuate any bleeding.
6. Mark the stereotactic reference point on the skull (e.g. Bregma) with fine-point permanent marker.
7. Insert pointer in stereotactic holder and move over reference point. Record axes coordinates.
8. Calculate burr hole coordinates. Move stereotactic holder to the hole and mark location with permanent marker. Remove the pointer.
9. Mark locations for anchor-screw holes and ground hole.
10. Drill screw holes with small dental burr, being very careful not to penetrate the dura. For the ground hole, the dura is pierced.
11. Insert anchor screws (suggested screws: 3/32" 00-90 or 0-80 hex-head screws). The bottoms of the heads should clear the skull by .5 to 1.5 mm.
12. Drill the burr holes with a core drill (approx 1.3 mm dia). Do not penetrate the dura.
13. Carefully scrape away the dura in the burr holes.
14. Attach the microdrive holder to the Stereotactic Adapter. Attach the microdrive to the holder.
15. Move the guide tube over the stereotactic reference point and lower the microdrive until the guide tube clears the skull by less than 1 mm. Adjust the A-P and Lateral coordinates until the guide tube is well centered over the

reference mark. Record the coordinates.

16. Calculate the new coordinates for the guide tube and move the stereotactic fixture to them.
17. Unwrap the ground wire from the lower cone and attach it to the proper screw. Take up excess slack in the wire by wrapping it back and forth around a pair of adjacent screws.
18. Lower the microdrive until the guide tube touches the brain surface.
19. Fill around the tip with Vaseline to seal it. Keep the Vaseline confined to the tip; do not allow it to smear onto the skull area that is to be bonded with dental acrylic.
20. Mix small batches of dental acrylic and fill around screws and the replaceable tip, slowly building up the mass with sequential batches. Cover the screws, ground wire and build up around the lower portion of the cone. The final shape of the cement mass should be smoothly formed around the tip and feathered out onto the skull to facilitate comfort for the animal.
21. Suture the incision, bringing the skin over some of the dental acrylic. Do not pull too tight.
22. Release the microdrive and remove the holder. Remove the animal from the stereotactic fixture.

## 7 Recycling the Microdrive

After the microdrive has been removed from the animal, it can be recycled for further use on other animals. Because of the nature of the bonding technique, the polyamide tubes must be discarded. If care is taken when removing the tube assemblies from the drive plates, the drives will be fully reusable. The outline below suggests a sequence to be followed.

1. Remove the microdrive from the animal. If dental acrylic has been kept away from the attachment screws, then only chipping it away from around the ground wire will be required. Carefully work the adhesive off with a sharp knife. Avoid cutting into any part of the cone. If a gel-type adhesive was used to bond the guide tube to the body, carefully cut it away, avoiding cutting the guide tube. The tube then can be removed by holding with pliers and twisting the tube until any remaining bond is broken. When the tube is pulled out of the body, it will take with it the intermediate polyamide tubes. If there is any cement on the cone that isn't easily scraped away, it can be softened by soaking the cone

in a shallow dish of acetone for an hour. This makes the cement somewhat rubbery.

2. Remove the drives from the body. Cut the tetrode wires with scissors and the drives should be readily removable.
3. Remove the tube assemblies from the drive plates. Cut the top of the tubes and any glue fillet off flush with the top of the drive plate with a sharp razor blade. If care was taken to minimize the amount of Cyanocrylate used to attach the assembly to the plate, the tube should pull out fairly easily. If it resists use a .022" dia drill in a pin vise to clean out the tube remaining in the hole. Be very careful not to twist the drill sideways in the hole and put excessive strain on the drive plate. Do not apply any pressure to the drive screw or it may bend. Do not attempt to use any debonder or other solvents to soften the adhesive; they may produce stress cracks in the plastic drive plate.
4. Remove tetrode wires from the connector board. It may be helpful to remove the board from the microdrive (make note of the orientation of the board on the microdrive.) Some cactus needles will protrude through the board by 3 or more millimeters. It may be best to cut all of the needles off with diagonal pliers so that about 1 mm protrudes. Use a flat-bladed screwdriver to pop the cactus needles back up through the plate. Try to push on them straight along their axes to avoid bending and breaking. If some do break, use a flat-ended piece of .015" music wire (available at hobby shops), held in a pin vise, to push on the cactus needle. The wire should extend only about ½ mm from the pin vise for the first push. It may have to be extended more to push the loosened cactus needle out of the board. After all of the needles and bits of tetrode wire have been removed from the board, replace it on the microdrive.

At this point, the microdrive should be ready to be reassembled with new polyamide tube assemblies.

Appendix A – Potential Vendor List

Polyimide tubing

PD Wire and Cable  
Trenton, GA  
800.241.1075

HVT Technologies  
Trenton, GA  
706.657.7700

MicroLumen Tampa,  
FL 813.886.1200

Flat-tip oilers

S. LaRose, Inc.  
Greensboro, NC  
888.752.7673

Part No. OL-350 (extra small - black)

Dental acrylic

Patterson Dental  
Wilmington, MA  
800.842.5355

Hygenic Repair Resin, veined

Small screws

J. I. Morris Company  
Southbridge, MA 508.764.4394

Tungsten ground wire

A-M Systems, Inc.  
Carlsborg, WA  
800.426.1306

Catalog No. 7960  
(.003" wire, .0045" dia insulated)

Cyanocrylate adhesives

Any local hobby shop

Pacer Zap, Zap-A-Gap, Slo-Zap and  
Zap Gel. Also house brands and accelerator.

Tower Hobbies  
Champaign, Il.  
800.637.4989

Home Depot

Super Glue Gel and Future Glue Gel

Dispensing bottle for accelerator

Contact East  
800.225.5370

Precision Dispenser, Part No. 121-723,  
Needles, Part No. 121-755 (.009 ID)

Small Parts  
800.220.4242

Squeeze Bottles, Part No. U-SQB-02,  
Needles, U-NE-301PL or U-NE-271PL

## 8 Appendix B – Microdrive Parts Identifier

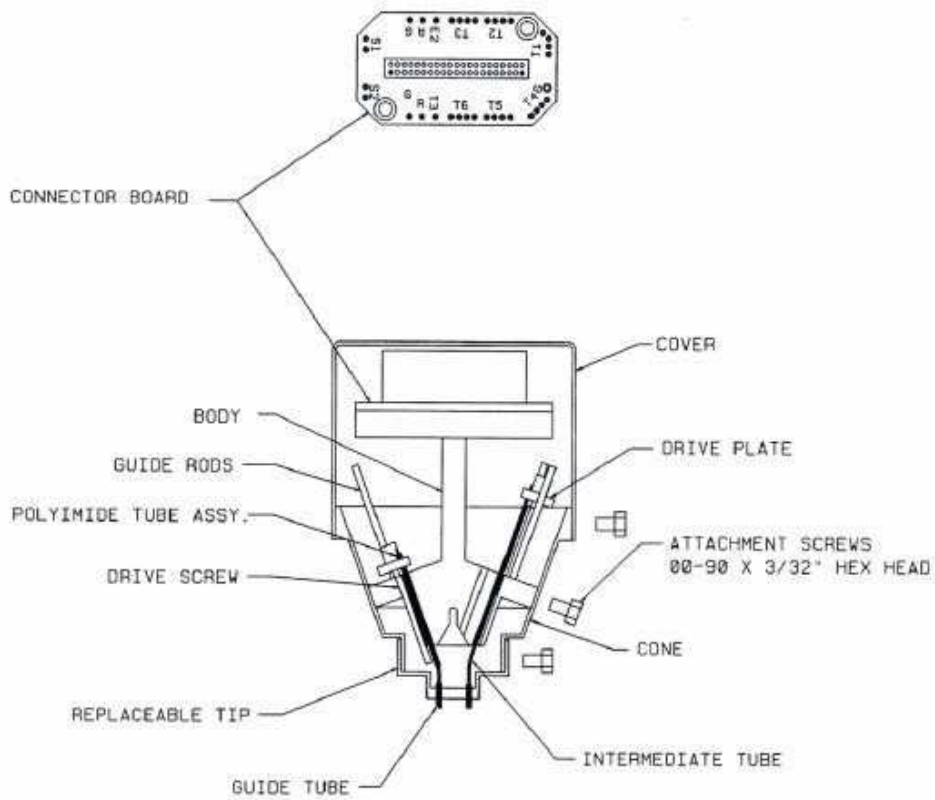

Figure 8.1 Microdrive Parts Identifier

The Harlan 4 Drive is compatible with Neuralynx's EIB-16 (on left) or EIB-18 (on right).

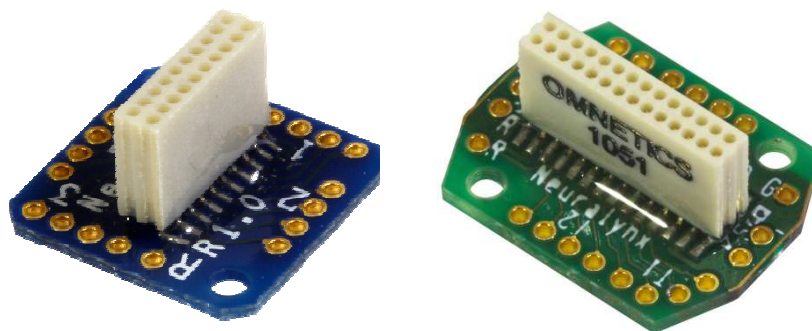

Figure 8.2 Neuralynx's EIB-16 and EIB-18