

Ver. 1.0

XNET Network Box Camera (IGB1110PF/IGB1110NF) Installation Manual



About this Installation Manual

A compatibility and durability test ensured this product's high performance.

This installation manual is for XNET IP Box Camera users only, and it describes operations related to XNET IP Box Camera.

Please read this manual thoroughly paying attention to cautions and warnings before using the product even if you have used similar products before.

Important Notices

The copyright of this manual is owned by CNB Technology Inc.

It is illegal to copy and distribute this manual without permission.

Damages caused by use of not suggested parts and misuse will not be applicable for support.

Contact the store or the manufacturer immediately if (you think) there is any problem with the product.

Contact the store or the manufacturer before disassembling the product for alteration or repair.

XNET is a trademark of CNB Technology Inc.

This product complies for CE (Europe) and FCC (USA) regulations for industrial/home use electrical device.

INFORMATION

This equipment has been tested and found to comply with the limits for a Class A digital device, pursuant to Part 15 of the FCC Rules. These limits are designed to provide reasonable protection against harmful interference when the equipment is operated in a commercial environment. This equipment generates, uses and can radiate radio frequency energy and, if not installed and used in accordance with the instruction manual, may cause harmful interference to radio communications. Operation of this equipment in a residential area is likely to cause harmful interference in which case the user will be required to correct the interference at his own expense.

Index

- 1 . About XNET 4**
 - 1.1. About XNET 4
 - 1.2. Features of XNET 4
 - 1.3. Applications 4
- 2 . About the Product 5**
 - 2.1. Contents 5
 - 2.2. Product Information 5
 - 2.3. Functions and Designations 6
 - 2.3.1. Side View 6
 - 2.3.2. Rear View 7
 - 2.3.3 Connecting to Alarm devices 9
- 3 . Software Installation 10**
 - 3.1. Connecting XNET to network 10
 - 3.2. Installing IP-Installer Software and Configuring IP address 11
 - 3.2.1. About IP-Installer 11
 - 3.2.2. Configuring IP Address 11
- 4 . Using Web Viewer 13**
 - 4.1. Logging In 13
 - 4.2. Web Viewer Page 14
- 5 . Specifications 17**

1. About XNET

1.1. About XNET

XNET is an internet based security and surveillance system that is compatible with various network conditions through easy installation and user interface as well as multi-functional compressor Codec such as MJPEG, MPEG-4, and H.264. XNET provides stable real-time surveillance by real time video/ audio at D1 level, local storage for any network problems, and hybrid IP technology that can be used with existing analog CCTV devices.

1.2. Features of XNET

Most advanced Video/ Audio compression technology (MJPEG/MPEG-4/H.264, ADPCM/G726)

Hybrid IP Technology - CCTV analog video output can be used for existing analog CCTV devices.

Transmission of Multi-Codec stream - Live video signal can be compressed to MJPEG or MPEG-4 (or H.264) and sent to meet various applications of network or user.

2-way Audio Communication (Bi-directional voice communication between Client's PC and XNET)

Smart Event feature - On the top of motion detection and sensor/alarm feature, pre- and post- alarm feature allows automated surveillance without an attendant's monitoring.

Install/ Operation Wizard - Install/ Operation Wizard not only makes it easy for installers and users, but also offers a unified installation setup for massive scale installations.

Up to 3 motion detection areas

Motion Detection – Alarm output and Video/ Audio data transmission to FTP site or e-mail upon detecting a motion.

RS-485 interface for Remote Pan/Tilt control

Remote Control over the network for software upgrade

1.3. Applications

Surveillance (Building, store, factory, parking lot, financial institutions, government buildings, military facilities, etc.)





Remote video monitoring (Hospital, kindergarten, traffic monitoring, remote branch office, weather, environment preservation, and illegal disposal of trash, etc.)

Real time broadcasting over the internet (Resort facility, parties, festivals, etc), remote business meetings, and educational trainings, etc.

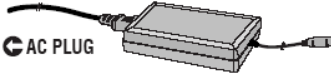

2. About the Product

2.1. Contents

Please make sure the following contents are included when you open the package.

Contents	Description	Additional info.
XNET product	IP Box Camera (Lens not included)	
Auto Iris Lens Plug	Connection plug for Auto-Iris control signal	
Power adapter	Input: 100~240VAC 50-60Hz Output : 12VDC, 2A	
AC power Cord	2 jack cable	
CD	Software and User's manual	

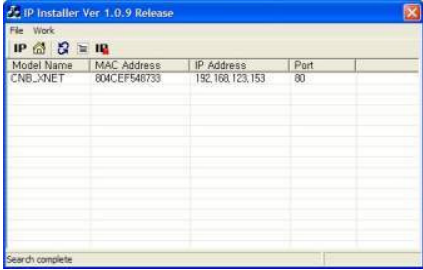
2.2. Product Information

XNET (IGB1110xF)	Install CD	
	IP-Installer	Viewer Program (XNET-NVR)
		
IP Camera (Lens not included)	A software that assigns an IP address to the product	A software that monitors and records Audio and Video signal from the device (processes up to 16 channels)

2.3. Functions and Designations

2.3.1. Side View

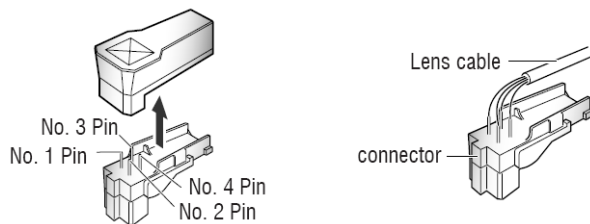

Figure 2-1. IP Camera Side view

- Lens (Sold separately): C or CS mount/ Fixed or Vari-Focal DC Auto-Iris lens.
- Auto-Iris Control Plug: Plug for Auto-Iris control

The following shows each pin connection:

Pin No.	Signal
#1	Damping coil (-)
#2	Damping coil (+)
#3	Drive coil (+)
#4	Drive coil (-)



Strip 8mm of outer jacket of the lens cable, and then strip 2 mm of inner wires to solder them to the connection plug.



2.3.2. Rear View

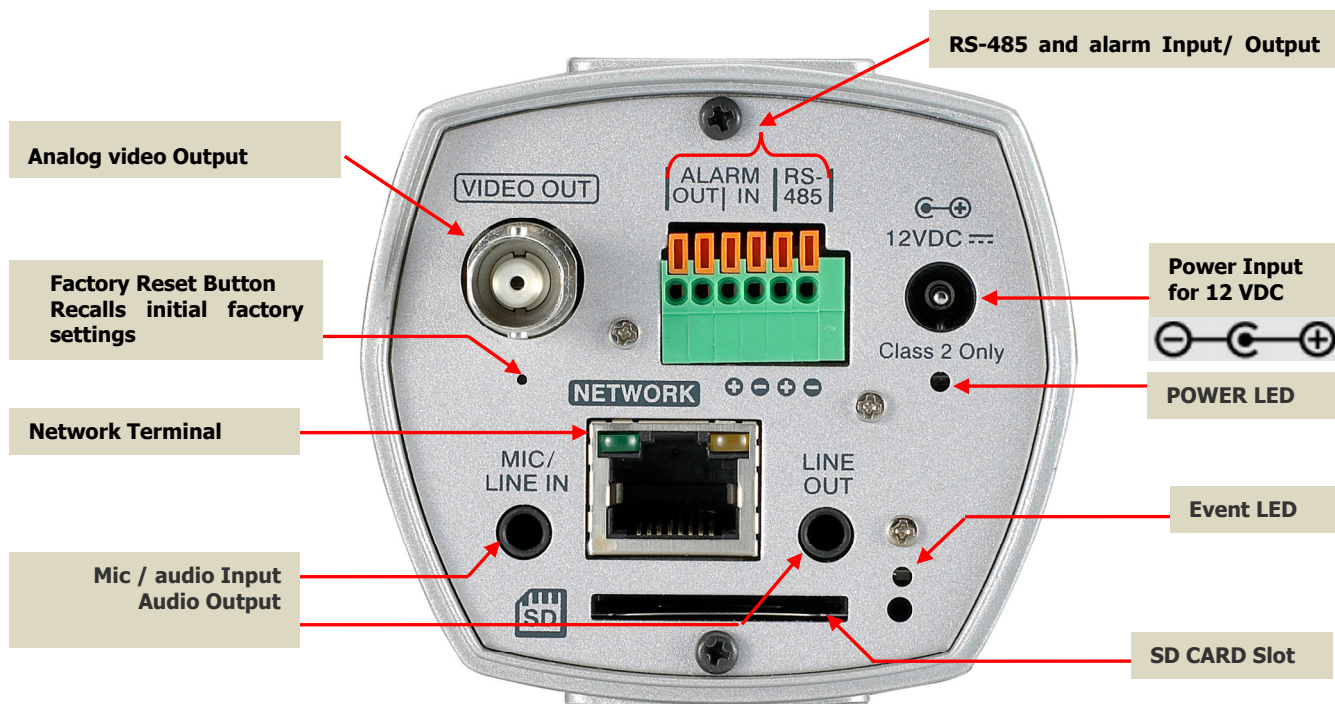

Figure 2-2. IP Camera Rear view

MIC / LINE IN: Connects to auxiliary Audio Device or microphone. 3.5 mm mono/ stereo audio connector is used. For connection, refer to the figure below:

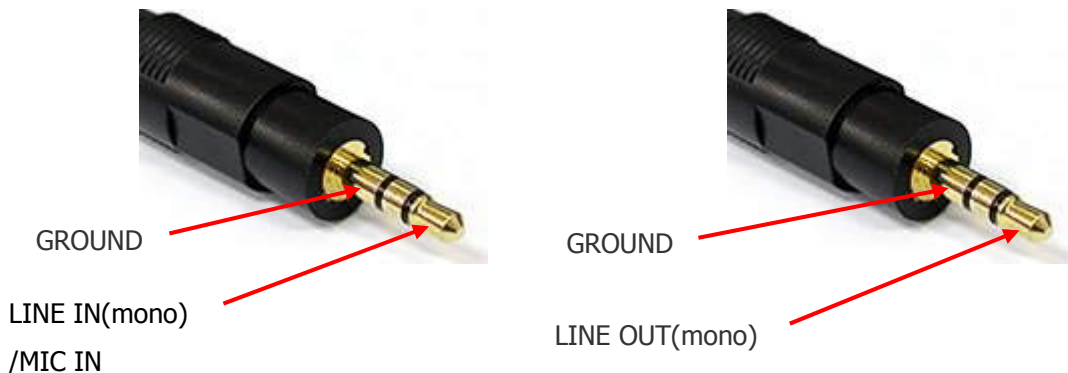

Figure 2-3. Connector for MIC/LINE INPUT and Audio LINE OUT

LINE OUT: Audio signal output to a Power Amplified device or Speaker. This can be used to listen to the audio signal sent from a remote PC for Bi-directional Audio communication.

VIDEO OUT: Use this output to monitor the analog video signal while installing.

(Select Video Out at menu screen to enable this output)

Factory Reset Button: Press and hold for more than 3 seconds while power is on to recall factory default settings

NETWORK : This Ethernet terminal connects to 10Mbps or 100Mbps LAN through an RJ-45 connector.

When optional PoE is used, the power will be supplied from the Network Cable.

- **LINK :** Yellow light indicates that the network is properly connected.
- **ACT :** Green light indicates that the XNET system connected to 100Mbps LAN. This green lamp will blink if the system receives data.

STATUS LED : Indicates the operation status

- **EVENT LED :** Green light indicates that Alarm Out signal is turned on.
- **POWER LED :** Red light indicates that 12V DC power is connected.

RS-485 and ALARM In/Output Terminal

Pin	Description	Set up
1	Alarm Out	Select NC/NO at menu screen
2	Alarm Out	
3	Alarm In(+)	Select NC/NO at menu screen
4	Alarm In(-)	
5	RS485 +	-
6	RS485 -	

- **RS-485:** When properly connected, you can remotely control Pan/Tilt device with RS-485 control interface.
- **Alarm In:** This connects to an Alarm Sensor signal. Only one sensor can be connected.
- **Alarm Out:** This connects to an external Alarm device that operates by a relay such as Siren Lamp or Alarm Light. Only one Alarm device can be connected.

SD CARD SLOT : Enables recording of video data to an external memory device upon occurrence of an event. Please use less than 4 GB SD Memory.

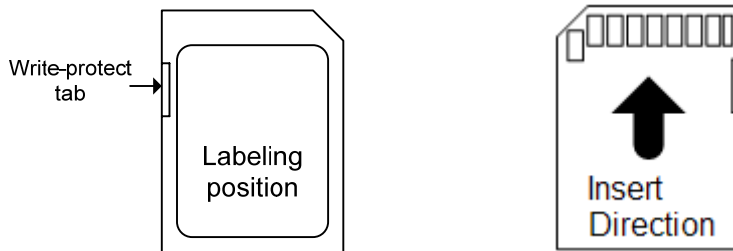

Figure 2-4. SD CARD

Power Terminal: Connect 12V DC Power to this terminal.

	<p>Do not use this connector when powering up the product through LAN cable. (PoE) The product is not covered under warranty when it is damaged by connecting both Ethernet power and 12V DC power to this terminal.</p>
--	--

2.3.3 Connecting to Alarm devices

Alarm Input

Wires from various sensor type (IR, heat, and magnetic) can be connected to Alarm in(+)/(-) terminal as shown in figure 2.5. (NC or NO of sensor input can be selected at Menu screen.)

Alarm Sensor device requires a separate power source.

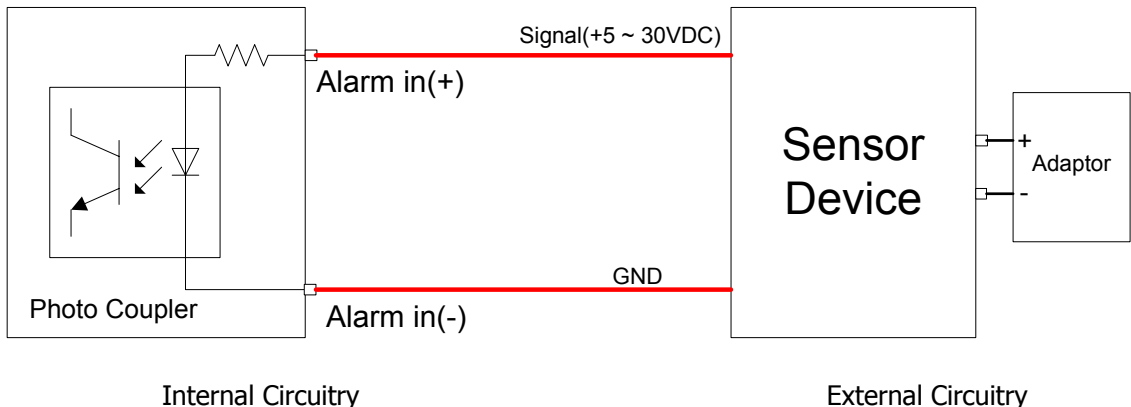

Figure 2-5. Connecting to Alarm Input

Alarm Output

This terminal can only be connected up to AC 30V/400mA or DC 30V/400mA. An additional relay device has to be used to control higher voltage or current.

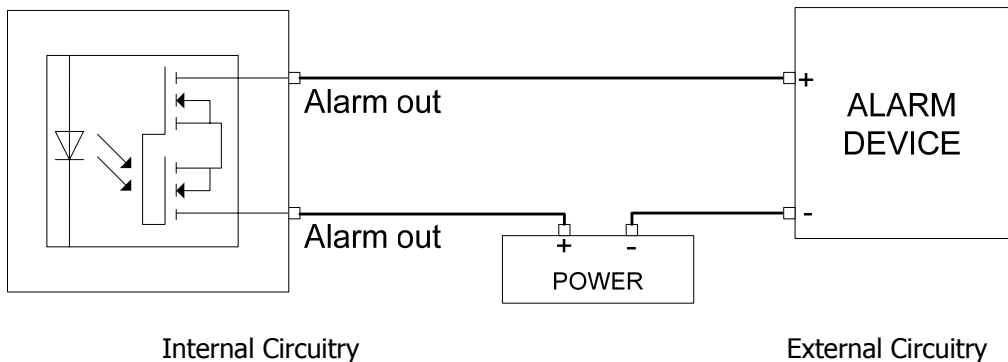

Figure 2-6. Connecting to Alarm Output

3. Software Installation

This section provides brief guidelines to install the XNET software quickly and to monitor XNET's Video and Audio signals easily. If you have questions about details not explained in this section or if the product is not functioning as described, please refer to FAQ before contacting the store.

Our homepage is <http://www.cnbtec.com>.

3.1. Connecting XNET to network

1. A PC or a laptop computer is required to set up an IP address.

- Compatible operating system: Windows 2000/ Windows XP/ Windows Vista
- Since the default IP address of the device is 192.168.123.100, set up the IP address of the computer like the following: IP Address : 192.168.123.101 Subnet Mask : 255.255.255.0

2. Connect a monitor to VIDEO OUT terminal.

(Select Video Out at Menu screen to enable analog video output.)

3. Connect LAN cable to the Network Terminal of the product. (Use a crossover cable when connecting it directly to a PC, and use a direct cable when connecting it to a HUB)

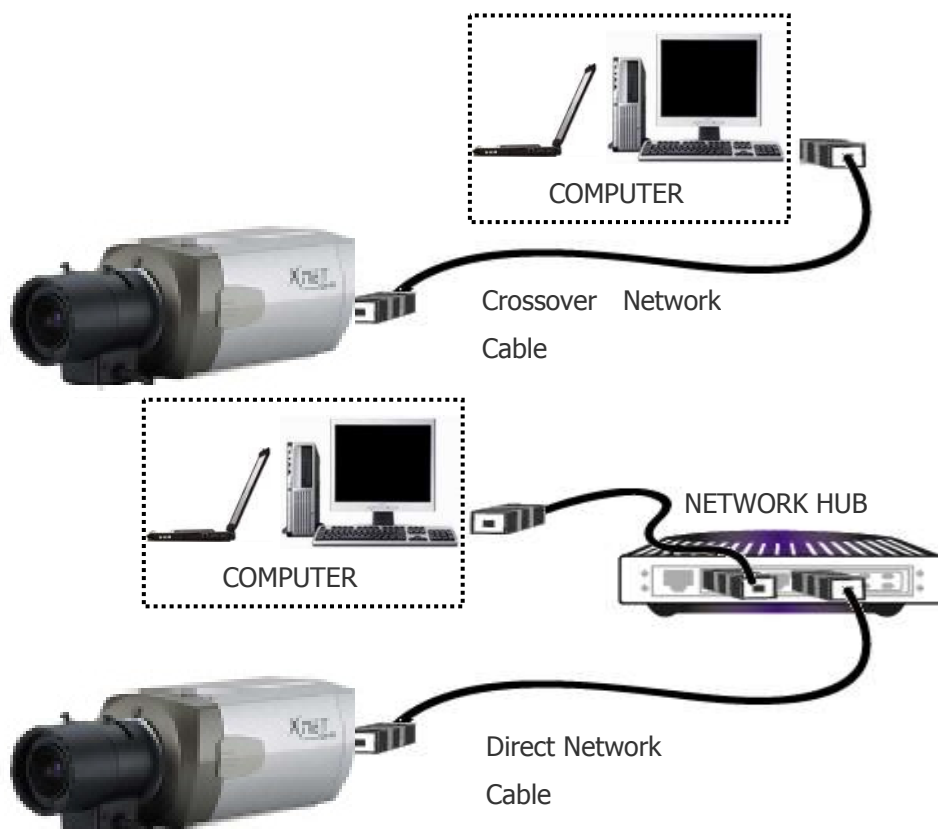

4. Connect the camera to the power.

5. Use the Alarm Sensor/ output and audio terminal if necessary.

2. Select the camera of which you wish to change the IP address and click **IP** (Set IP Address) button to bring up the following box in Figure 3-3.

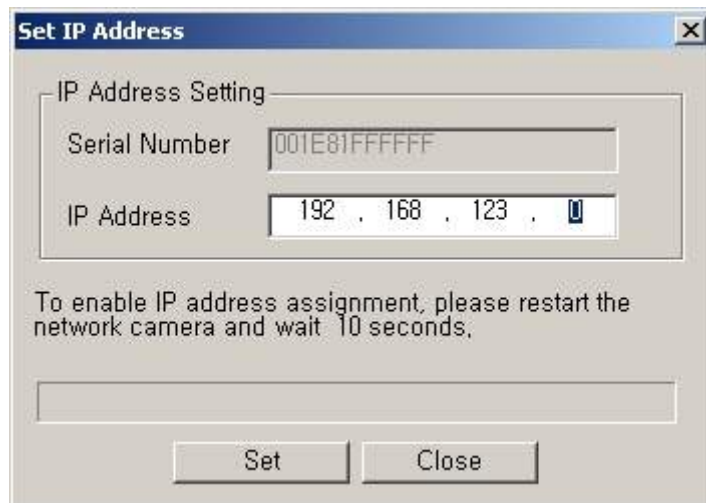

Figure 3-3. IP Address box

3. When you enter the IP address and click Set button, the box shown in Figure 3-4 will appear.

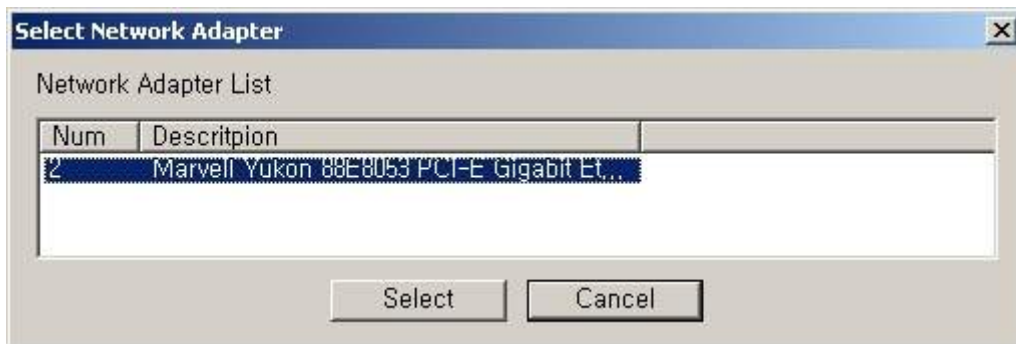

Figure 3-4. Select Network Adapter Box

4. Select the adapter and click select button to change the IP address of the camera.

4. Using Web Viewer

Connecting to network devices can be done using internet web browser or “XNET-CMS” software. This manual explains about using internet web browser only. For instructions on how to configure network connection using XNET-CMS software, please refer to XNET-CMS Manual, which can be found in the installation CD.

4.1. Logging In

Enter the IP address of the device on the address bar of your web browser and press enter key. Then the following webpage will appear:

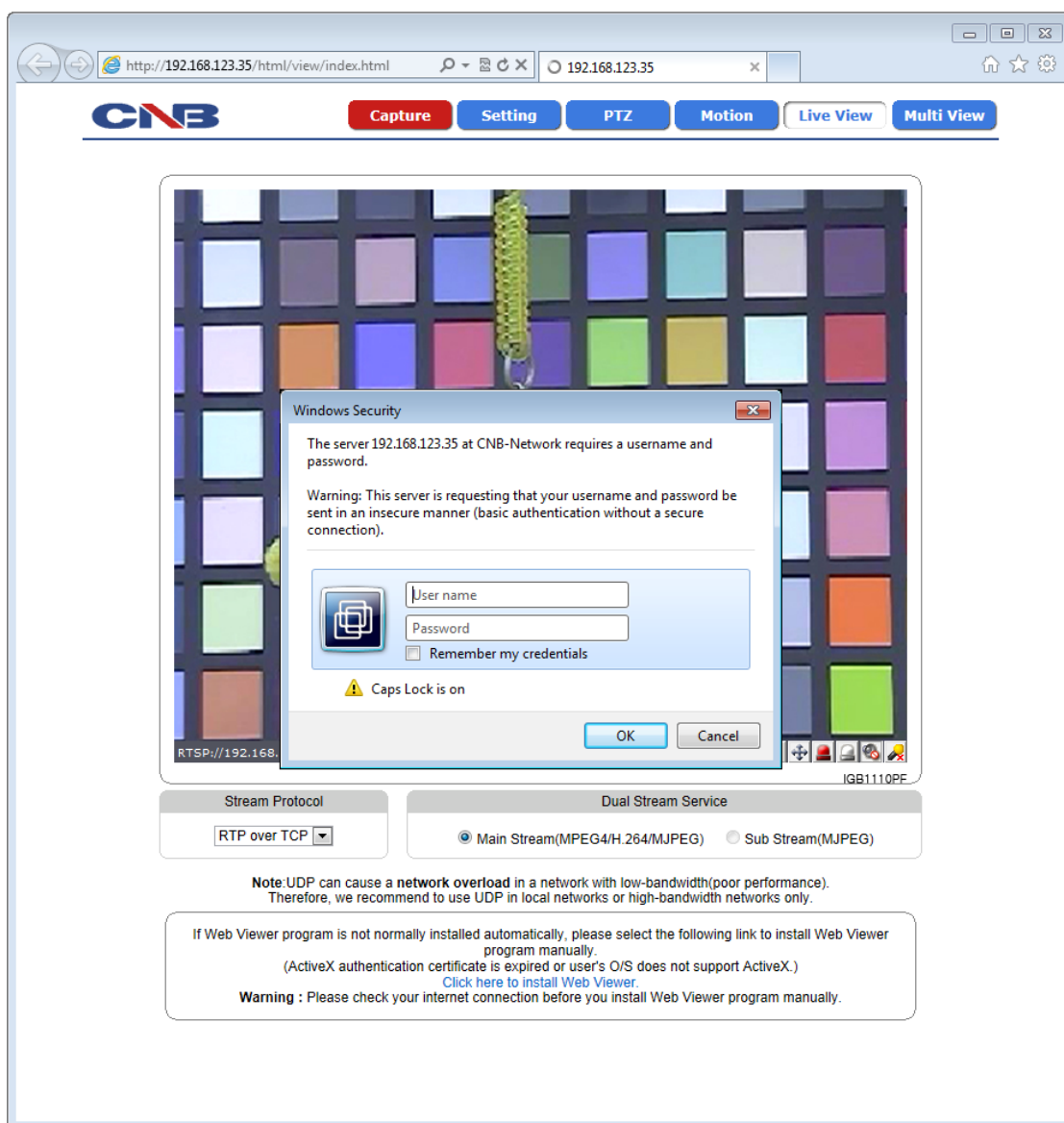

Figure 4-1. Log-in Box

Enter the user name and password to bring up the web viewer page. The default id and password is "root", "admin" respectively. If you want to use a different HTTP port number from the default value, simply put a colon and port number at the end of the IP address. (For example, enter the following address when changing the port to 8080: **http://192.168.123.100:8080**)

<Address format for accessing as an administrator>

(When using default IP address and port number) ***http://192.168.123.100***

(When IP address and port number changed) ***http://IP address: new port number***



For security, please change the administrator's id and password from their default values. Please save the changed ID and password in a place only accessible by an administrator. Please refer to [**Web Viewer Manual**] for detail.



If you forget the administrator's password, "Factory Reset" is the only way to regain access. However, since this will retrieve all default settings, the network settings have to be configured again using the IP installer.

4.2. Web Viewer Page

Web viewer page consists of Video monitor screen and menu option buttons.

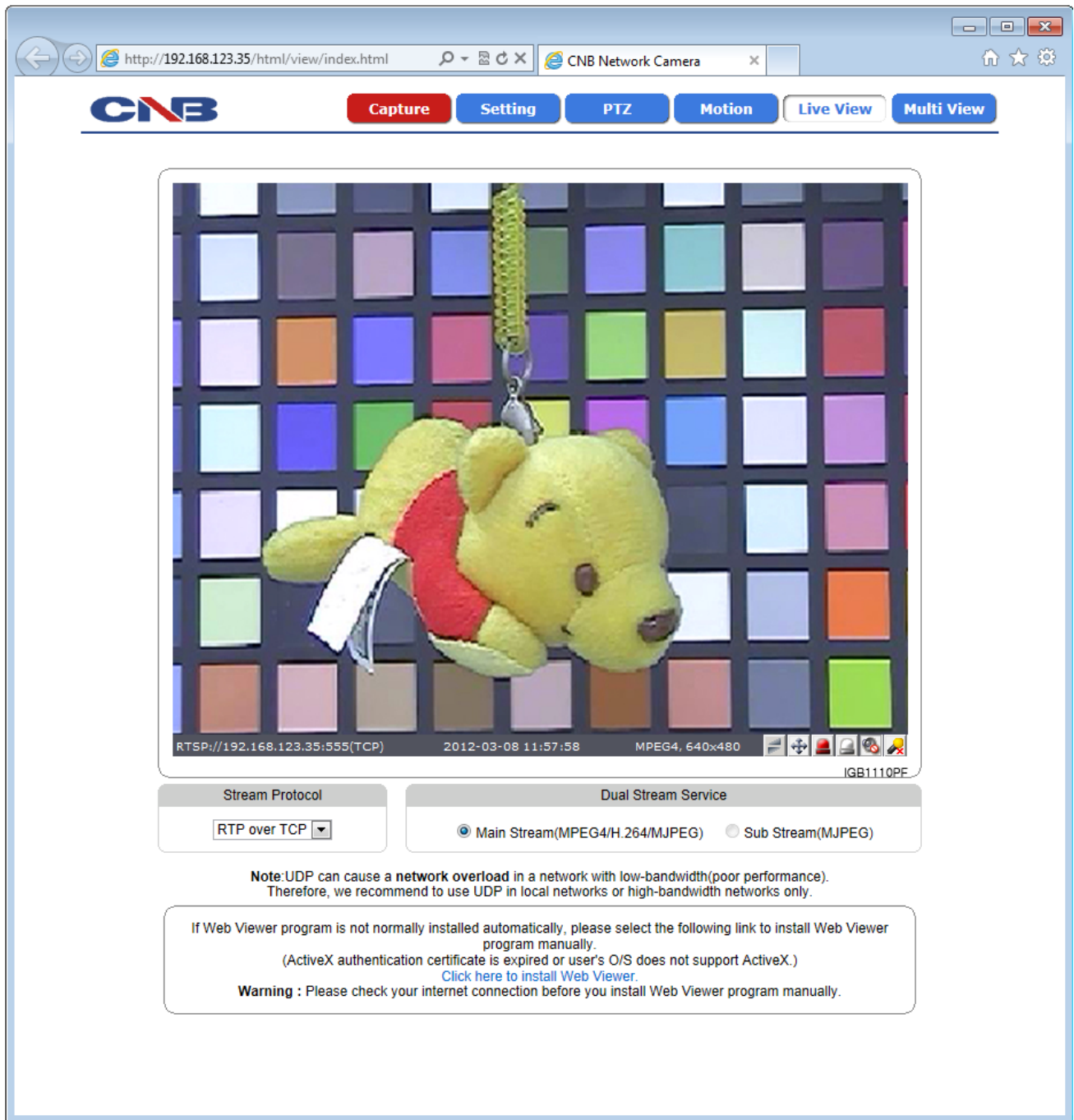

Figure 4-2. Web Viewer Page

Item	Sub Item	Description
Capture	-	Captures and saves the current image as a still picture. The image is saved as jpeg file in the following folder: C:\WxNetCapture
Setting	-	Brings up Menu screen. Setup page for each XNET feature can be opened from this Menu screen. Please refer to [XNET Owner’s Manual] for detail.
PTZ	-	Opens up PTZ page. This page can set up digital PTZ of the IP camera and control of PTZ movement. Please refer to [XNET Owner’s Manual] for detail.
Motion Detection	-	Opens up Motion Detection page. You can add or delete areas for detecting motion in this page. Please refer to [XNET Owner’s Manual] for detail.
Multi View	-	Opens up Multi View page. You can view videos from cameras that are programmed in Multi Video Player setup page. Please refer to [XNET Owner’s Manual] for detail.
Live View	Main Stream	When this box is checked, Main Stream Video is displayed.
	Sub Stream	When this box is checked, Sub Stream Video is displayed. Dual-Codec needs to be enabled in Video Setup Page in order for Sub Stream to be displayed. Please refer to [XNET Owner’s Manual] for detail.

5. Specifications

	IGB1110xF	Specifications
Camera	Signal System	NTSC (IGB1110NF) / PAL (IGB1110PF)
	Scanning System	2:1 Interlace
	Scanning Frequency (H)	15.734kHz / 15.625kHz
	Scanning Frequency (V)	59.94Hz / 50Hz
	Image Sensor	1/3" High Sensitivity CCD
	Sync. System	Internal
	Total Pixel Number	811(H) x 508(V) 410K / 795(H) x 596(V) 470K
	Effective Pixels Number	768(H) x 494(V) 380K / 752(H) x 582(V) 440K
	Horizontal Resolution	580 TV Lines
	Video Output Level	1.0Vp-p (75Ω, composite) / Digital Interface with ITU656
	S/N Ratio	More than 52dB (AGC off, BW mode)
	Lens Mount	CS Mount
	Min. Illumination	0.05 Lux(Color) / 0.0002 Lux(DSS On, B/W)
	Day & Night System	ICR(AGC Type)
	White Balance	Auto/Manual(Red, Blue Gain Adjustable)
	AGC / BLC	Off / Low / Middle / High
	Digital Slow Shutter	Off/2x~128x Field
	OSD Menu	Control ON/OFF over IP
	WDR (Wide Dynamic Range)	Up to 60dB (Low/Middle/High)
	3D-DNR	Level (0~63)
	Brightness, Sharpness	1~100
	Eclipses Function	On/Off (16 Zones)
	Privacy Zone	Control On/Off(8 zone settings) over IP
	Stabilizer	On/Off
D-Effect	V-Flip / Mirror / Rotate	
Electronic Shutter Speed	1/60~1/90,000 Sec. / 1/50~1/90,000sec.	
Video / Audio	Compression	MJPEG / MPEG4 / H.264
	Frame rate	Single Mode : Main(H.264@30fps) *D1 Dual Mode : Main(H.264/MPEG4, 30fps), Second(MPJEG) *D1
	Resolution	D1 (NTSC: 704 x 480 / PAL: 704 x 576) CIF (NTSC : 352 x 240 / PAL: 352 x 288)
	Video streaming	MJPEG / H.264 (or MPEG4) Dual mode Constant and variable bit rate in MPEG4 (128kbps ~ 3M bps) Controllable frame rate and bandwidth
	Audio	Two-way (Full duplex / ADPCM G.726)
Network	Protocol	Ipv4, HTTP, HTTPS, UDP, TCP, RTSP, RTP, SMTP, FTP, ICMP, DHCP, UPnP, Bonjour, ARP, DNS, DynDNS, NTP, IGMP(Multicast) *) OnVif
	Supported DDNS	1. CNB DDNS 2. DynDNS.org 3. Reference code with SDK
	LAN Interface	Ethernet 10/100 Base-T (RJ-45 Type)
	Support PoE	Standard IEEE 802.3af supported
Security	Access level setup	Multiple user access levels with password protection
	Network Security	IP Filtering
Alarm and Event Management	Image detection	Motion detection (Select 3 Regions - each area)
	Sensor detection	Sensor In, Scheduling, Alarm out
	After Event process	JPEG Image upload over FTP server / SMTP (E-mail server)
	Local storage	JPEG Image write to Internal & SD card memory - Internal memory : Max 32MByte / SD memory : Support size Max 4GByte

XNET Network Box Camera Installation Manual

	Pre / Post alarm	Detail time-set : Max Pre alarm 5 sec / Post alarm 8 sec Local storage (Internal memory or SD card memory : JPEG image)
Applications	Browser	Internet Explorer 6.0 or later
	Monitoring Application	CNB NVR, CNB CMS and Utility (IP-Installer, etc)
Maintenance	System Upgrade	Firmware upgrade over HTTP
	PTZ control (RS-485)	PTZ Protocol Service (User define update)
Mechanical	Operating Temperature	0℃ ~ 40℃
	Power	DC 12V Max. 5 W
	Dimensions / Weight(Net)	137.9(D) x 91(W) x 62(H) mm

