



Lab Biological Microscope
Model Number
BM-800

User Manual

This manual is written for lab biological microscope BM-800. For safety, exerting best performance of the instrument, and making you familiar with the instrument entirely, we strongly recommended that you carefully read this manual before using the microscope.

Use Notices

1、 Name of Components	1
2、 Installation	2
2-1、 Installation Diagram	2
2-2、 Installation Steps	3
3、 Adjustment	7
4、 Operation	9
5、 Technical Specifications	13
6、 Trouble Shooting	14

I、 Safety note

1. Carefully open the box, avoid the accessories, like lens, dropping to ground and being damaged.
2. Do keep the instrument out of direct sunlight, high temperature or humidity, dusty and easy shaking environment. Make sure the stage is smooth, horizontal and firm enough.
3. When moving the instrument, please use two hands to grip with the two sides of the microscope body.
4. If the bacterium solution or the water splash to the stage, objective or viewing tube, pull out the power cord at once, and wipe up the microscope. Otherwise, the instrument will be damaged.
5. When running, the lamp house and nearby parts will be very hot. Please ensure there is enough cooling room for them.
6. Make sure the instrument is earthed, to avoid lightning strike.
7. For safety, be sure the main switch is in "O"(off) state before replace the halogen lamp or the fuse, then cut off the power, and do the operation after the lamp bulb and the lamp house completely cool.
8. Check the input voltage: be sure the input voltage which signed in the back of the microscope is consistent with the power supply voltage, or it will bring a serious damage to the instrument.
9. Use the factory supplied power cord, please.

II、 Maintenance

1. All the lenses have been well checked and adjusted. It is forbidden to disassemble them yourself.
2. The nosepiece and coarse/fine focus unit have a compact and precise frame, please don't disassemble them as possible as you can.
3. Keep the instrument clean, wipe dust regularly, and be attention to avoid contaminating the optical elements especially.
4. The contaminations on the prism, as finger mark and oil, could be gently wiped with a piece of soft cloth or tissue paper, gauze which has been immersed in pure alcohol or xylene. **(note that the alcohol and the xylene are all burned easily, do not let them near the fire, and use them in a drafty room as possible as you can.)**
5. Don't use organic solvent to wipe the non-optical elements, when you need to clean, use the soft detergent, please.
6. When using, if the microscope is splash by liquid, cut off the power at once, and wipe up the moisture.
7. Do not disassemble any parts of the microscope. That will affect the function or decline the performance of the microscope.
8. Place the instrument in a cool, dry position. After using the microscope, remember to cover it with dust helmet. Do wait for the lamp house cooling completely before cover.

1. Name of Components

BM-800

Eyepiece (Ocular)

Video Port (optional)

Trinocular Viewing Unit

Nosepiece

Objective

Mechanical

Lamp House

Microscope Body

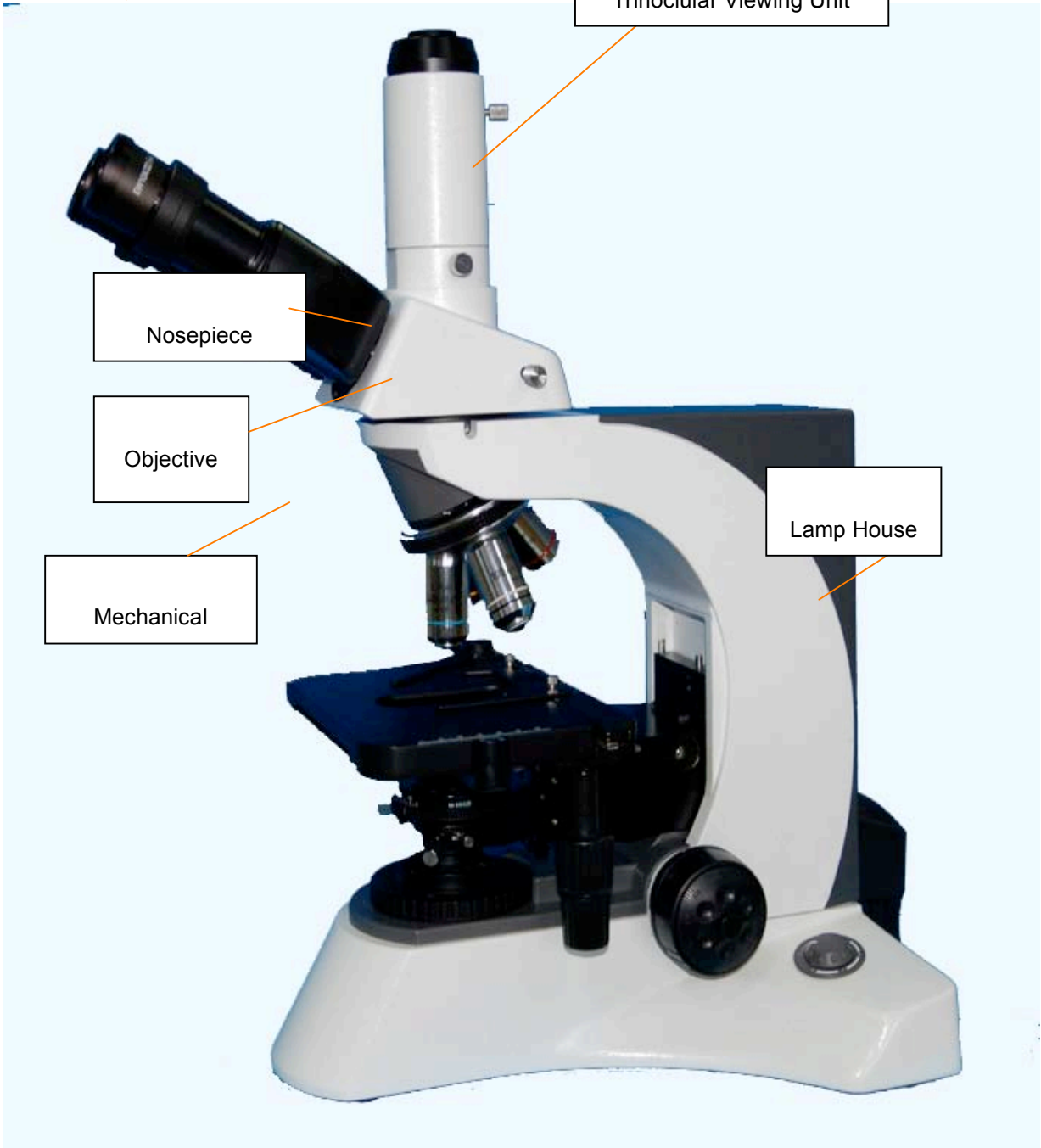

2-1 Installation Diagram

The following figure shows the installation sequence of the components. The number in the figure show the installation steps.

- ★ **Before installing, be sure every components is clean, do not score any parts or glass surface.**
- ★ **Keep well with the supplied hexagon wrench. When changing the components, you will need it again.**



Video Port (optional)

⑥



10 × Wide Field
Eyepiece

②

Trinocular Viewing Unit

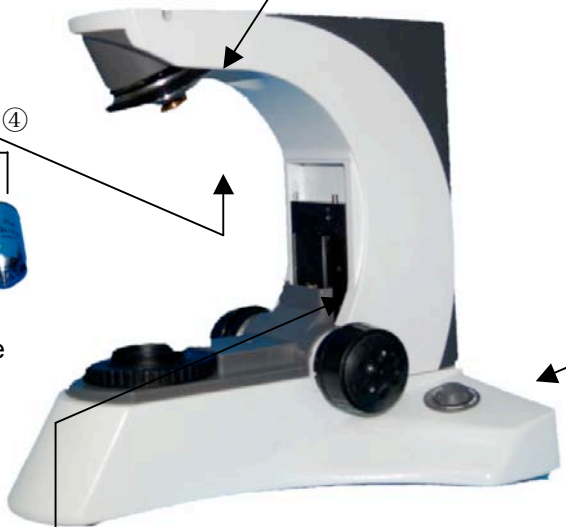

④

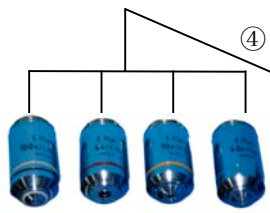

Infinite Plan Objective

①

Microscope Body



Mechanical
Device

Stage

Support



Lamp House

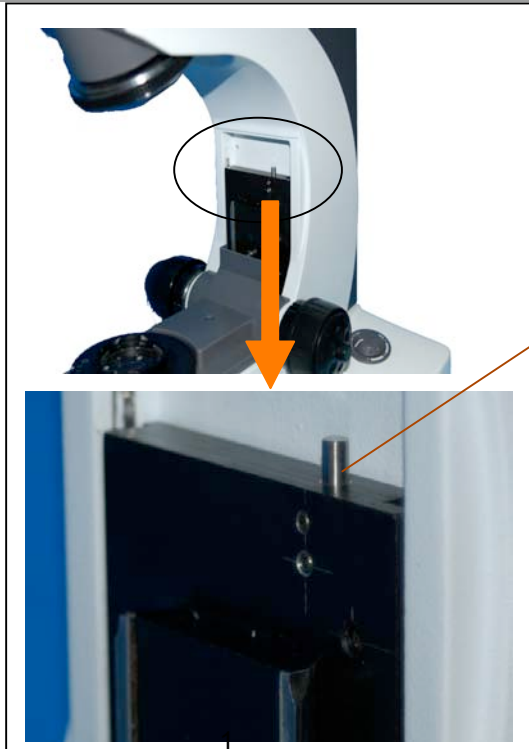

Guide Board

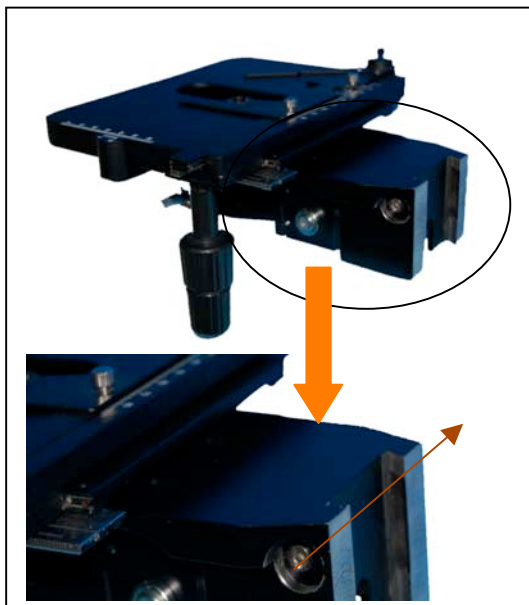

Locking Block and Bolt

2



3

2-2-1 Installing the Mechanical Stage Support Device

- ★ Before installing the device, be sure to adjust the coarse focus knob. Make the guide board (see figure 1) down to the lowest position, so you can install the mechanical stage support device easily.

- ✧ Hold on the mechanical stage support device (figure 2), place it from the top of the guide board (figure 1), let the device (figure2) falling free until it reach the limit position. Use the hexagon wrench screw down the locking block, make the stage support device (figure1) and the guide board fixed together.

- ★ **The mechanical stage have been adjusted horizontally and fixed together before leaving factory. Do not disassembly unless necessary, that may affect the observation precision of the instrument.**

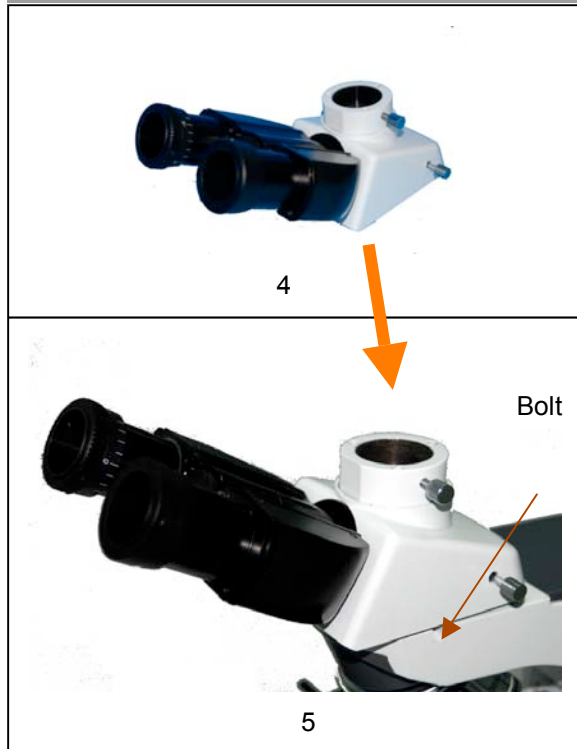

2-2-2 Installing the Trinocular Viewing Unit

Insert the trinocular viewing unit (figure 4) into the microscope head (figure 5), turn to a proper position, then use the hexagon wrench screw down the bolt to fix (See figure 5).

2-2-3 Installing and Replacing the Lamp (figure 6)

◇ Please use the specified halogen Lamp 6V30W.

1. Hold to the bulb after you wrap it with gauze or other protection materials, and then deeply insert it into the lamp holder.

2. Replacing Lamp when using or soon after

When using, or soon after it is turned off, the lamp, the lamp house and nearby parts will be very hot and will cause serious burns. Please turn the main switch on "O" (off), pull out power plug, and make sure the bulb, the lamp room and periphery are all cool. Then, you can do your replacing.

★ Please insert the lamp gently, or it will be damaged by excessive extrusion

★ **Do not touch the Halogen bulb with your bare hands. It will shorten the service life or cause it to burst. If you leave finger marks on the surface carelessly, clean it with a dry soft cloth.**

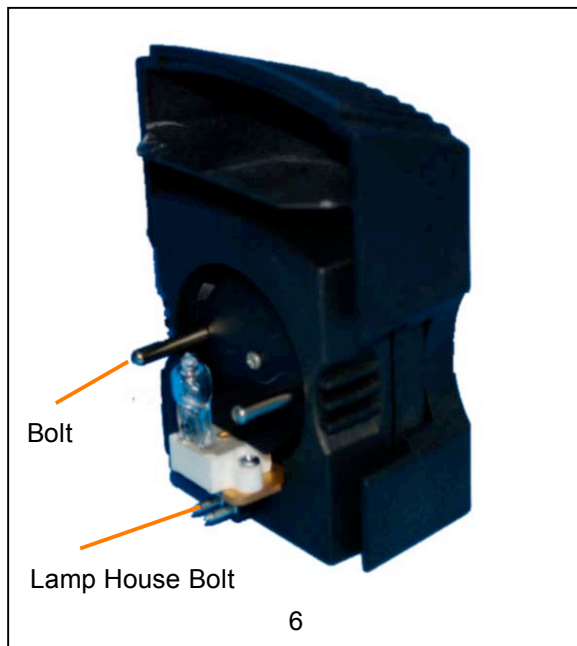

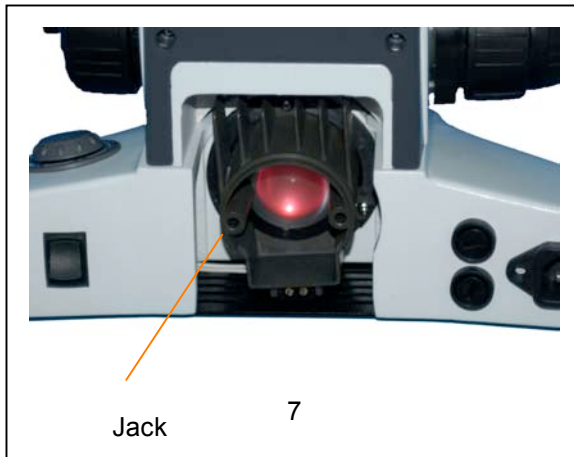

2-2-4 Installing the Lamp House

✧ Keep the bolt on the lamp house (figure 6) in line with the jack on the back of the microscope (like the show of figure 7), then pushing the lamp holder into the illumination kits gently until they are against each other (figure 8).

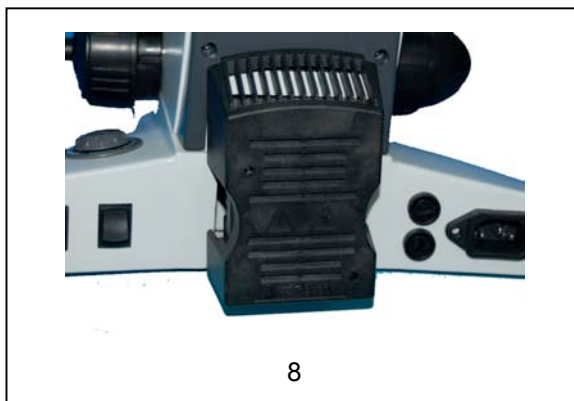

2-2-5 Installing the Objective

1. Adjusting the coarse focus knob until the support device of the mechanical stage reach its low limit position.
2. Wresting the lowest magnification objective onto the nosepiece from the left or the right side (figure 9), then push the nosepiece clockwise, then place other objectives by the sequence of low to high magnification (figure 10).

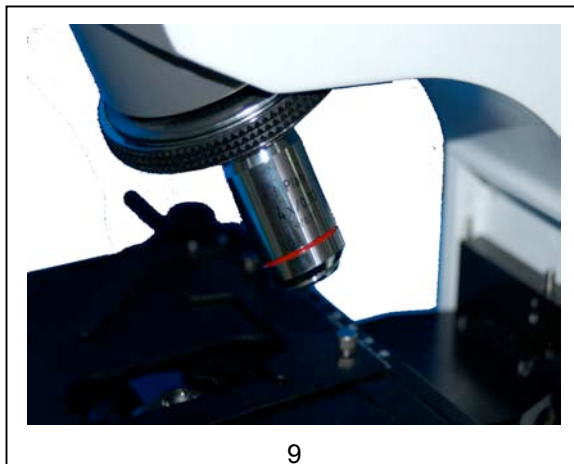

✧ Installing objective this way will make the change of magnification to be easier while in using.

★ Clean the objective regularly, the objective of the inversed microscope is very sensitive to dust.

★ **When operating, use 10× magnification objective to search specimen and focus firstly, then replace with higher magnification objective if necessary.**

★ **When replacing the objective, slowly turning the nosepiece until you hear “clicked”, that means the objective enter the required position--the light path center.**

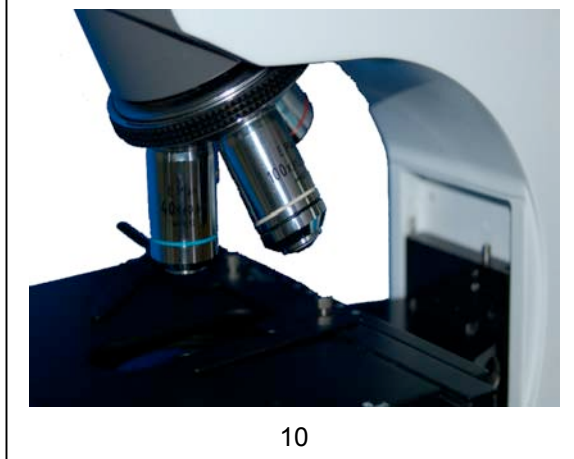

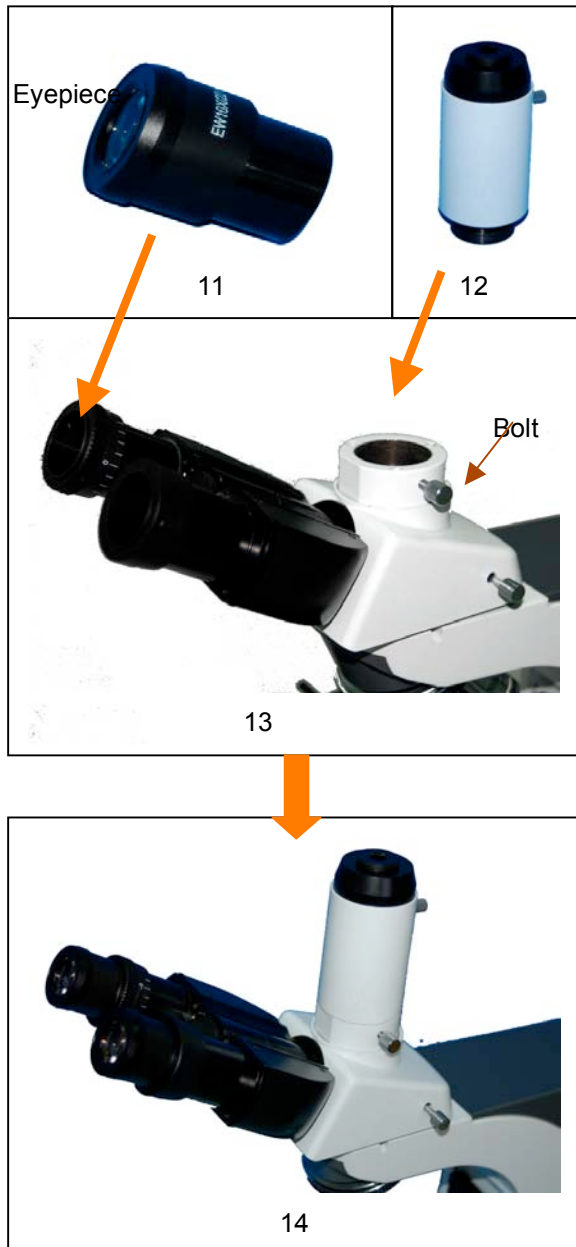

2-2-6 Installing the Eyepiece

Insert the eyepiece (figure 11) into the eyepiece tube until they are against each other. The result is showing in the figure 14.

2-2-7 Installing the Video Port (optional)

Insert the video port (figure 12) into the trinocular unit (figure 13), then screw down the bolt to fix it. The result is showing in figure 14.

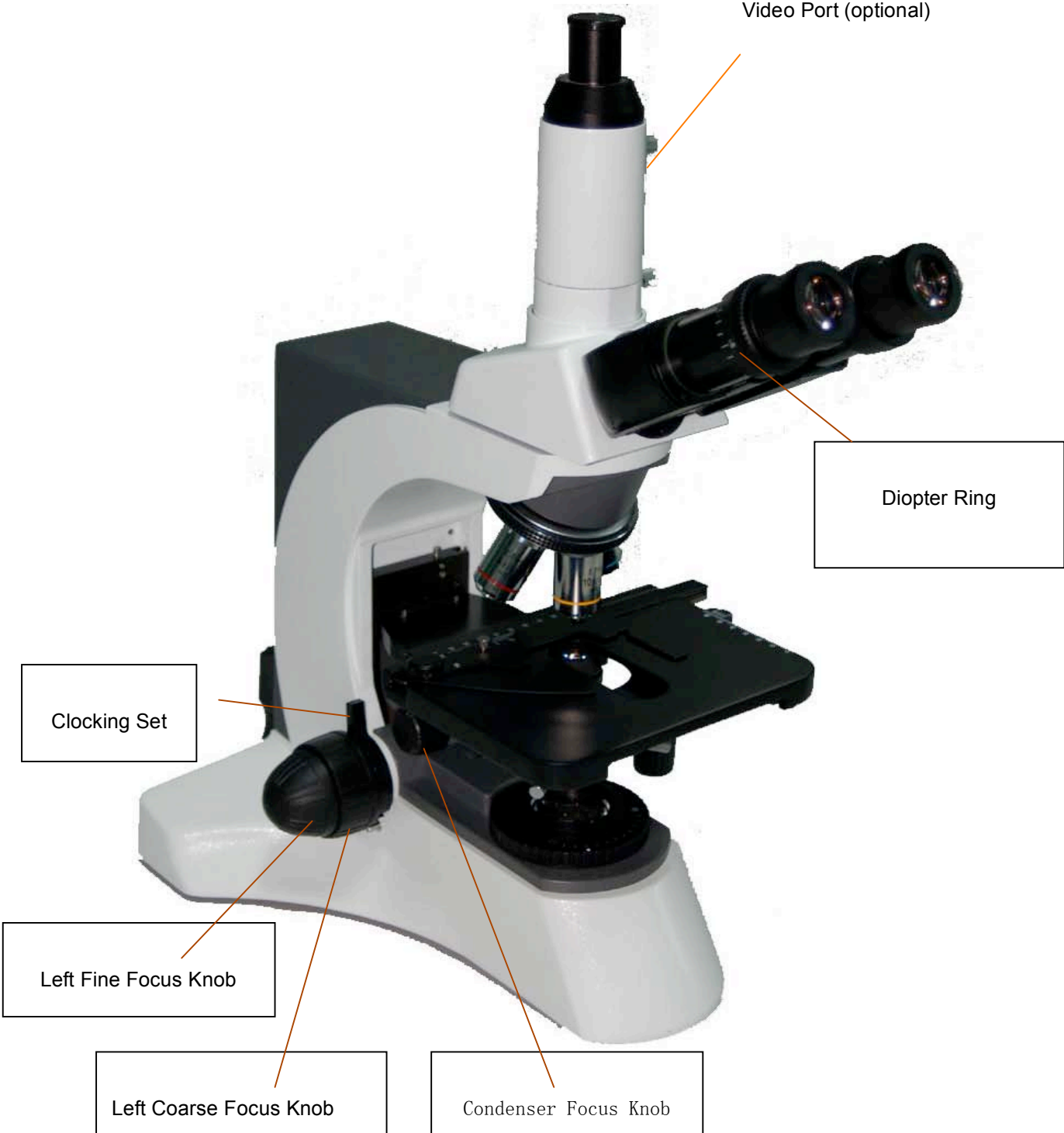

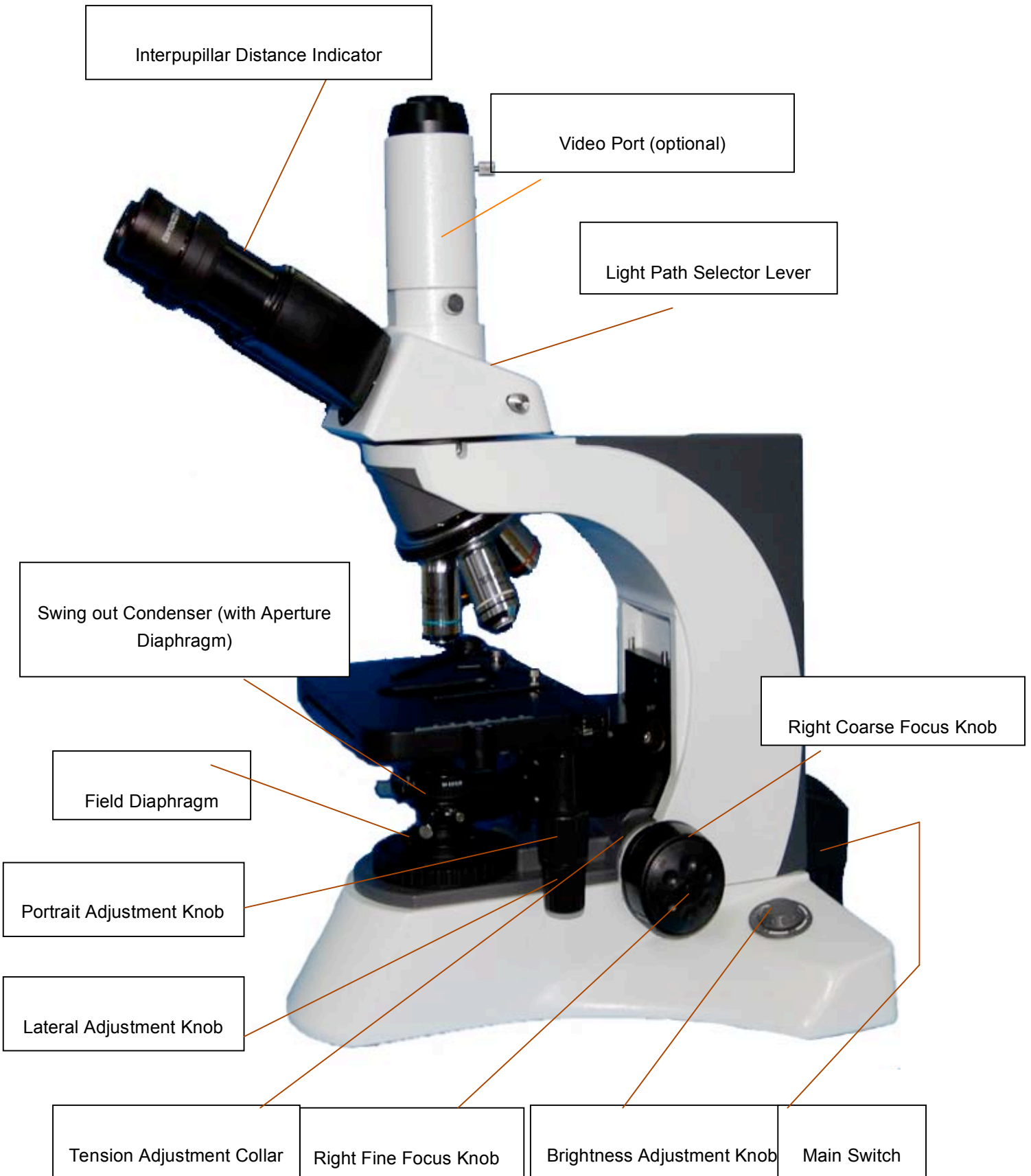

Note : the video port is optional.

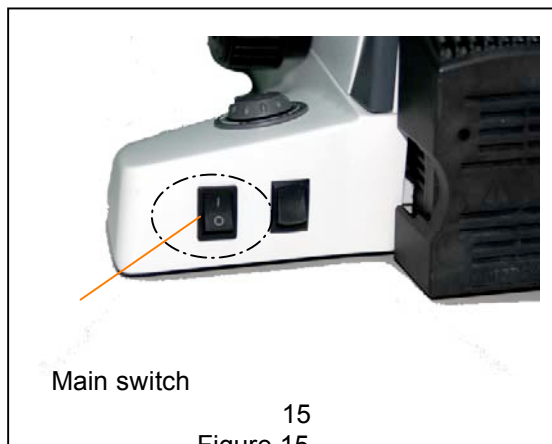

4-1 Turning on the Lamp (Figure 15)

Connect the power, turn on the main switch (figure 15) to “-”(on).

4-2 Adjust Brightness (Figure 16)

Turning the brightness adjustment knob clockwise, the voltage raise, and the brightness strengthen; turning with the anti-direction, the voltage decline, and the brightness weaken.

✧ Using the lamp in a low voltage condition, will prolong the use life.

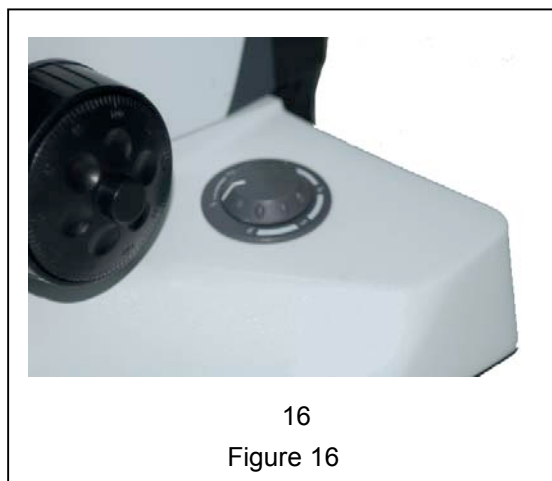

4-3 Adjust the Tension Adjustment Collar (figure 17)

★ The tightness of the tension adjustment collar has adjusted before leaving factory, if finding it's loosing (the mechanical stage drop itself because of deadweight), please turning the tension adjustment collar until the tightness is in order.





18
Figure 18

4-4 Placing Specimen(figure 18)

Place the slide on the mechanical stage. Use the stage clips to clamp the slide gently.

Turn the portrait and lateral adjustment knob of the mechanical ruler, move the specimen onto the required position.

★ **Be careful when changing the objective. If you finish the observation with the short working distance objective, and want to change another one, be careful of not letting the objective touch the specimen.**



19
Figure 19

4-5 Adjusting the Interpupillar Distance (Figure 19)

The interpupillar distance range: 48mm~75mm. When observing with two eyes, hold on the left and right prism holder, turn around the axis, adjust the interpupillar distance until the left and right fields of view coincide completely.

4-6 Adjusting the Diopter (Figure 20)

The right ocular tube is fixed. So by turning the left diopter ring after the right ocular focus on the specimen, the operator who's left and right eye has different eyesight can obtain a comfortable focus position with both eyes.



20
Figure 20



21
Figure 21



22
Figure 22

4-7 Focus (figure21, figure22)

1、 When not using the video set

Push in the light path selector lever (figure 25) completely, then observe with both eyes. Use the 10×objective focus, to avoid the objective touch with the specimen, you should raise the mechanical stage at first, let the specimen close to the objective, then slowly separating them to focus.

The operator can converse turn the coarse focus knob to get the specimen down ,and search images in the 10×ocular simultaneously, then use the fine knob to focus. At this moment, you can replace other magnification objectives safely, and focus without the risk of destroying the specimen.

2、 When using the video set

Pull out the light path selector lever (see figure25), observe with both eyes, when the image is sharp, you can see the pictures directly on the video screen which connected by the microphotograph system through the video mount.

★ **If you need to fix the stage on a vertical position to make the observation become more convenience, take use of the locking set.**

4-8 Adjusting the Swing out Condenser (Figure 23)

The center of the condenser and the light axes of the objective are coaxial. It has been adjusted before leaving factory, so the user needn't to adjust them by self.

The highest position of the condenser has been adjusted too. It also needn't any user's operation. Turn the condenser focus knob to shift the condenser. It needs to raise the condenser when using the high magnification objective, and to decline when using the low magnification one.

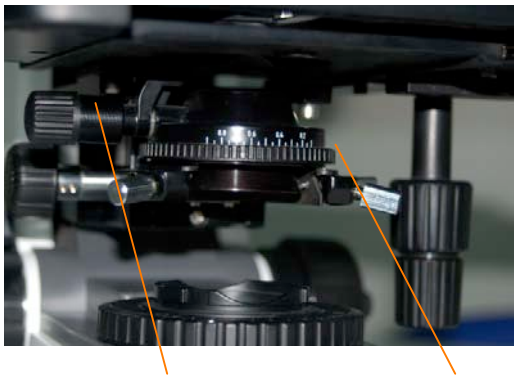

Swing out Condenser

Aperture Diaphragm

23
Figure 23

1. Using the Swing out Condenser

When using the low magnification objective, turn out the condenser, and let it away from the light path. While using the high magnification objective, turn it into the light path.

2. Adjusting the Aperture Diaphragm

The aperture diaphragm is designed for the adjustment of the numerical aperture, not for the brightness. Generally, reducing the diaphragm opening to 70- 80% of the N.A. value of the respective objective will provide an image of acceptable quality. If you want to observe the image of the aperture diaphragm, remove one eyepiece and look through the tube. You will see a dark circle encroaching on the bottom of the tube.



figure 24



figure25

4-9 Adjusting the Field Diaphragm (Figure 24)

The control for the field diaphragm is a ring used for adjusting the area of field diaphragm. When using, turn the ring to reduce the field diaphragm, look into the field, if the diaphragm image is faintness, do the follow steps: first, turn the condenser focus knob, shift the condenser holder to the position where the observed image of the field of view is sharp; then open the field diaphragm, let the image full of the field of view, reduce the mixed light, improving the quality of the image.

4-10 Switching the Light Path Selection (Figure 25)

When the light path selector lever on the trinocular viewing set is pushed in, all the light enters the binocular tube, so you can do the binocular observation. While the lever pull out, some part of light enters the binocular tube, the left go up, enter the video tube, so you can observe through the video equipment.

5. Technical Specifications

BM-800

一、 Main specifications

Optical System	Infinite Optical System
Viewing Head	Compensation Free Trinocular Head ,Inclined at 30, Interpupillar distance: 48-75mm
Eyepiece (Ocular)	Exceed wide field ocular EW10X/22, tube Φ 30 matched
Nosepiece	Backward Quintuple Nosepiece
Objective	Infinite plan Achromatic: 4 \times , 10 \times , 40 \times , 100 \times
Focus System	Coaxial Coarse and Fine Focusing System, Sensitivity and Graduation of Fine Focus: 0.001mm
Stage	Double layer mechanical stage, area: 185 \times 142mm, movement range: 75 \times 55mm
Koehler Illumination	Exposed illumination system, Aspheric collector, halogen lamp 6V30W
Condenser	Swing out condenser NA0.9/0.25

二、 Configuration Table

Viewing Head	Compensation Free Trinocular Head	●
Eyepiece	Extra Wide Field Eyepiece	●
Objective	Infinite plan objective: 4 \times , 10 \times , 40 \times , 100 \times	●
	Infinite Plan Objective: 20 \times	○
Condenser	Swing out Condenser NA0.9/0.25	●
Video Accessories		○
Video Mount	C Mount 1 \times	○
	C Mount 0.5 \times	○
Polarization Device		○
Turret Phase Contrast Device		○
Dark Field Device		○
Fluorescent Attachment		○
Temperature Control Device		○

Note: ●Standard outfit, ○ Optional

三、 Objective Specifications

Magnification	Numerical Value Aperture Diaphragm(N.A)	Working Distance (mm)	Thickness of Cover Slip	Conjugate Distance (mm)	Magnification Sign (Color loop)
4X	0.10	25.42	0.17	∞	Red
10X	0.25	11	0.17	∞	Yellow
40X	0.65	0.75	0.17	∞	Baby Blue
100X	1.25	0.21	0.17	∞	Black and White Circle

6. Trouble shooting

BM-800

Some problems will happen in the using of the microscope, you could solve them according the following list

PROBLEMS	REASON FOR PROBLEM	SOLUTION
I、 Optical Part:		
1、 Illumination is opening, but the field of view is dark.	The poor contact exists in the lamp house and the illumination system.	Ensure the contact pin and the lamp holder pin work well
	The lamp bulb spoils	change a new bulb
	The brightness adjustment knob is set too dark	Adjust the knob in a proper position
	No use the appointed lamp bulb	use the specified halogen Lamp 6V30W
2、 The edge of the field of view has shadow or the brightness is asymmetry	The nosepiece is not in the located position	Adjust it into the located position
	The surface of the lamp become black	Change a new lamp bulb
	The surface of the lens is moldy or has contaminant	Clean the lens
3、 Find dust and stain in the field of view	There are stains on the specimen	Change the specimen
	There are stains on the eyepiece	Clean the eyepiece
4、 The image is defocus\low-resolution	The objective damage	Mend and correct the objective (send to factory for overhauling)
	The lens of the objective and eyepiece is moldy or have contaminant	Do cleaning
	The opening of Aperture diaphragm and field diaphragm is not proper, and too much astigmatism.	Change the opening of the aperture diaphragm and field diaphragm
	Fine focus system is broken	Examine and repair the fine focus system(send to factory for overhauling)
	The objective is not in the center of the light path	Turn the nosepiece to the located position
5、 The image focus surface incline(one side is clear and the other side is faint)	The illumination light incline serious	Adjust the filament position ,let the light distributing of the field of view become symmetrical and bright
	The specimen don't correctly place	Put the specimen on the right position

	The nosepiece is not in the located position	Turn the nosepiece in the required position
6、 The eyes are uncomfortable, the left and right fields of view is not coincided .	The interpupillar distance is not correct	Adjust the interpupillar distance correctly
	The diopter is not right	Adjust the diopter according your sight
	Can't adapt to binocular observation	When look into the objective, do not stare at the specimen but at the whole field of view, or move the eyes away to see other things, then back into the objective

BM-800

PROBLEM	REASON FOR PROBLEM	SOLUTION
II、 Mechanical Part:		
1、 The coarse focus knob is hard to run	The tension adjustment collar is too tight	Loose properly
2、 The image can't stay on the focal plane in the process of the observation	The tension adjustment collar is too loose	Tighten properly
III、 Electric Part:		
1、 The lamp can't light	No power supply	Check the power cord, and connect them exactly
	the installation of the bulb is wrong	Install the bulb correctly
	The bulb burn out	Change a new bulb
The bulb burn out in a high frequency	Not use the specified lamp	Use the required lamp
2、 The height of the brightness is not enough	Not use a appointed lamp	use a appointed lamp
	The brightness adjustment knob is used wrong	Adjust the brightness adjustment knob in a correct way
3、 The light glimpse	The bulb is going to spoil	Change the bulb
	The power cord have a poor contact	Check the power cord, and connect them exactly