

8" AIR MOTOR 6" Stroke Also covers 66614 service kits.



**READ THIS MANUAL CAREFULLY BEFORE INSTALLING,
 OPERATING OR SERVICING THIS EQUIPMENT.**

It is the responsibility of the employer to place this information in the hands of the operator. Keep for future reference.

SERVICE KITS

- Use only genuine ARO® replacement parts to assure compatible pressure rating and longest service life.
- 66614 for general repair of 66523-B air motor.
- 90350 installation tool is recommended for repair of 66523-B air motor.

DISASSEMBLY

NOTE: All threads are right hand.

1. Force the (43) piston assembly up by pushing toward the top of the air motor (see figure 4).
2. Remove six (1) screws, releasing the (31) cap and (32) gasket.
3. Loosen the eight (45) screws, which hold the (33) valve plate and pin assembly, (30) valve guide, two (4) valve guides and the (5) valve plate, until the (30) valve guide and the two (4) valve guides can be removed by pulling upward (see figures 1 and 2).

(Use an Allen wrench to push out screws and washers as shown.)

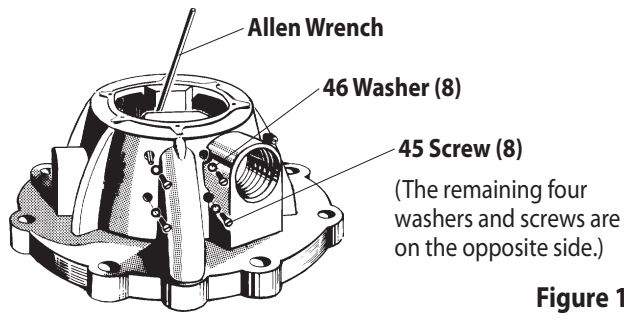

Figure 1

4. Remove the eight (45) screws and the eight (46) washers from the 8" air motor by pressure outward with a small Allen wrench (see figure 1).
5. Using a screwdriver, unhook the (28) insert spring assembly from the bottom of the (33) valve plate and pin assembly (see figure 2).
6. Remove the (28) insert spring assembly from the pins in the top of the (33) valve plate and pin assembly.
7. Pull the (2) valve piston upward until the (7) upper gland has pulled out of its chamber.
8. Remove the (7) upper gland.
9. Remove the (39) seal, (38) "O" ring and the (13) "O" ring from the (7) upper gland (see figure 7).
10. Disassemble the (2) valve piston from the (10) piston adapter (see figure 3).
11. Remove (2) valve piston.
12. Pull the (10) piston adapter upward and grasp the (11) extension rod below the (10) adapter. Push the (10) piston adapter down on the (11) extension rod. Remove the (37) washer and (11) extension rod.

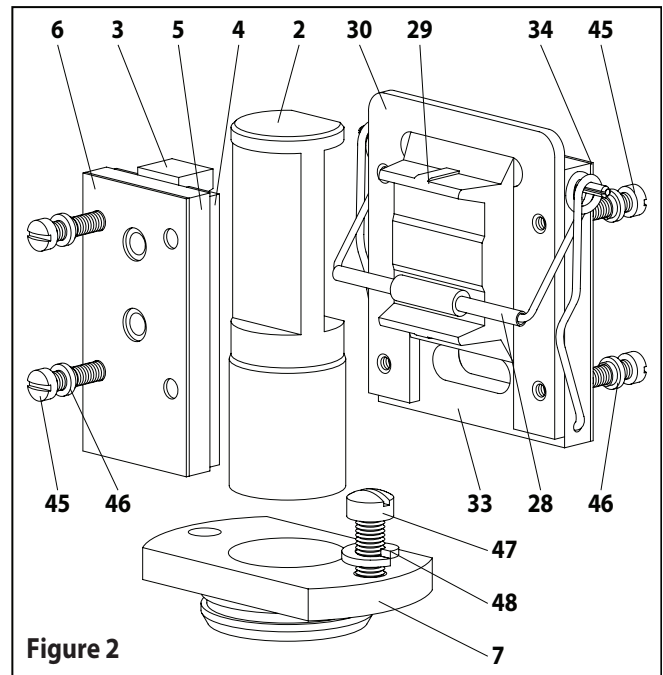

Figure 2

13. Remove the (8) upper washer and the (9) "U" cup packing from the (10) piston adapter.
14. Remove the six (22) nuts and (23) bolts.

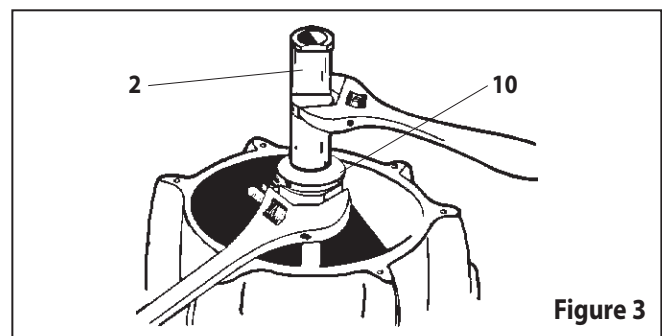

Figure 3

15. Remove the (35) head assembly and place on the workbench, with the end that the tube fits in, up.
16. Remove the (16) "O" ring from the (35) head assembly.
17. Remove the four (40) screws, releasing the (41) lower gland.
18. Remove the (12) lower washer and (13 and 42) "O" rings from the (41) lower gland.
19. Remove (44) tube.
20. Remove the "O" ring from the (44) tube.
21. Pull upward on the (18) air cylinder until the (43) piston assembly separates from the (26) air motor base assembly. If the (43) piston assembly is not pulled from the (26) air motor base assembly, remove it after removing the (18) air cylinder.
22. Remove the (16) "O" ring from the (26) air motor base and bearing assembly.

PARTS LIST / 66523-B

Item	Description (size)	(Qty)	Part No.
1	Screw (#10 - 24 x 1/2")	(6)	95956827
✓ 2	Valve Piston	(1)	92395
✓ 3	Pilot Insert	(1)	90487
□ 4	Valve Guide	(2)	90481
□ 5	Valve Plate	(1)	90480
✓ 6	Valve Plate Gasket	(1)	90482
□ 7	Upper Gland	(1)	91006
✓ 8	Washer	(1)	91344
✓ 9	"U" Cup (3/16" x 1-3/8" o.d.)	(1)	Y186-51
✓ 10	Piston Adapter	(1)	92393
□ 11	Extension Rod	(1)	90080
✓ 12	Washer	(1)	91345
✓ 13	"O" Ring (1/16" x 1-3/8" o.d.)	(2)	Y325-26
14	Screw	(1)	92218
✓ 16	"O" Ring (1/8" x 8" o.d.)	(2)	Y325-265
✓ 17	"O" Ring (1/4" x 8" o.d.)	(1)	Y325-443
□ 18	Air Cylinder	(1)	99398
□ 19	Valve Rod	(1)	90107-1
□ 21	Retaining Ring (2.630" o.d.)	(1)	Y147-237
22	Nut (1/2" - 20)	(6)	Y11-8-C
23	Bolt (1/2" - 20 x 10-1/4")	(6)	94046-1
□ 24	Guide Washer	(1)	92216
✓ 25	"U" Cup (1/4" x 1-3/4" o.d.)	(1)	Y186-24
26	Air Motor Base Assembly	(1)	66525-1

Item	Description (size)	(Qty)	Part No.
□ 28	Insert Spring Assembly	(1)	65807
✓ 29	Valve Insert	(1)	99202
□ 30	Valve Guide	(1)	90488
□ 31	Air Motor Cap	(1)	90078
✓ 32	Gasket	(1)	90083-1
□ 33	Valve Plate and Pin Assembly	(1)	65756
✓ 34	Valve Plate Gasket	(1)	90479
35	Head Assembly	(1)	66524-1
✓ 36	"O" Ring (3/32" x 7/8" o.d.)	(2)	Y325-115
✓ 37	Washer	(1)	90105
✓ 38	"O" Ring (0.103" x 1.255" o.d.)	(1)	91207
✓ 39	Seal	(1)	91007
✓ 40	Machine Screw (#8 - 32 x 3/8")	(4)	Y136-85-S
□ 41	Lower Gland	(1)	90114
✓ 42	"O" Ring (1/16" x 7/16" o.d.)	(1)	Y325-11
□ 43	Piston Assembly	(1)	62109-B
44	Tube	(1)	92215
□✓ 45	Machine Screw (#8 - 32 x 3/4")	(8)	Y19-89-S
✓ 46	Washer	(8)	90084
□ 47	Machine Screw (1/4" - 28 x 3/4")	(2)	Y119-49-C
48	Lock Washer (1/4")	(2)	Y14-416
49	Ground Lug	(1)	93006
✓	Gadus S2 U1000 Grease Pack	(2)	94833
✓	Items included in Service Kit		66614

□ "Smart Parts", keep these items on hand in addition to the service kits for fast repair and reduction of downtime.

23. Now remove the (21) retaining ring, (24) guide washer and (25) "U" cup packing from the (26) air motor base and bearing assembly.
24. (43) piston assembly is factory assembled and should not be disassembled.
25. Remove the (17) "O" ring from the (43) piston assembly. **CAUTION: Do not mar the finish on the piston rod.**
26. Disassemble the (43) piston assembly from the (14) screw.
27. Unscrew the (19) valve rod from the (11) extension rod by holding (19) valve rod with adjustable-type pliers and placing a wrench on the flats provided at the top of the (11) extension rod.

ASSEMBLY

NOTE: All threads are right hand. Inspect and replace old parts with new parts as necessary. Look for deep scratches on metallic surfaces. Replace all "O" rings upon reassembly. Lubricate all "O" rings and "U" cups with Gadus® S2 U1000 grease upon reassembly.

1. Place (17) "O" ring onto the (43) piston.
2. Place the (14) screw onto the (19) valve rod. The threaded end of the screw should be down, away from the threaded end of the valve rod.
3. While holding the (19) rod assembly below the threads with locking type pliers, clean threads with solvent and apply Loctite® 271™ to the threads and attach the (11) extension rod.
4. Place the (19) valve rod into the hole in the end of the (43) piston assembly and screw the (14) screw into the (43) piston assembly.
5. Thoroughly grease and install the (16) "O" ring in the (26) air motor base and bearing assembly.
6. Place the (25) "U" cup packing, (24) guide washer and (21) retaining ring in the (26) air motor base and bearing assembly.
7. Grease and install (13) "O" ring on the (41) lower gland.
8. Grease the bore in the (35) head assembly and insert (41) lower gland into the bore of the (35) head assembly with a twisting motion.
9. Align the bolt holes in the (41) lower gland and (35) head assembly and secure with four (40) screws.
10. Push the (43) piston assembly through the (25) "U" cup packing in the (26) air motor base and bearing assembly, being careful not to damage the "U" cup packing.
11. Thoroughly grease the inside of the (18) cylinder.
12. Apply grease to (17) "O" ring, then insert into the bottom of the (18) cylinder (see figure 5).
13. Push the (43) piston assembly to the top of the cylinder.
14. Thoroughly grease and install the (42 and 16) "O" rings in the (35) head assembly.
15. Thoroughly grease the two (36) "O" rings and install one on each end of the (44) tube.
16. Press the (44) tube into the counterbored hole in the (26) air motor base and bearing assembly.
17. Push the (11) extension rod through the (42) "O" ring in the base of the (35) head assembly.
18. Align and press the (35) head assembly down until the (18) cylinder and (44) tube are seated in the head assembly.
19. Insert the six (23) bolts down through the holes in the flanges of the (35) head assembly and the air motor base and bearing assembly.
20. Screw the six (22) nuts on the six (23) bolts. Alternately and evenly tighten the nuts.
21. Thoroughly grease and install the (9) "U" cup packing in the (10) adapter, with the lips of the packing down toward the thick flange of the (10) piston adapter.
22. Thoroughly grease and install the (38 and 13) "O" rings in the (7) upper gland.

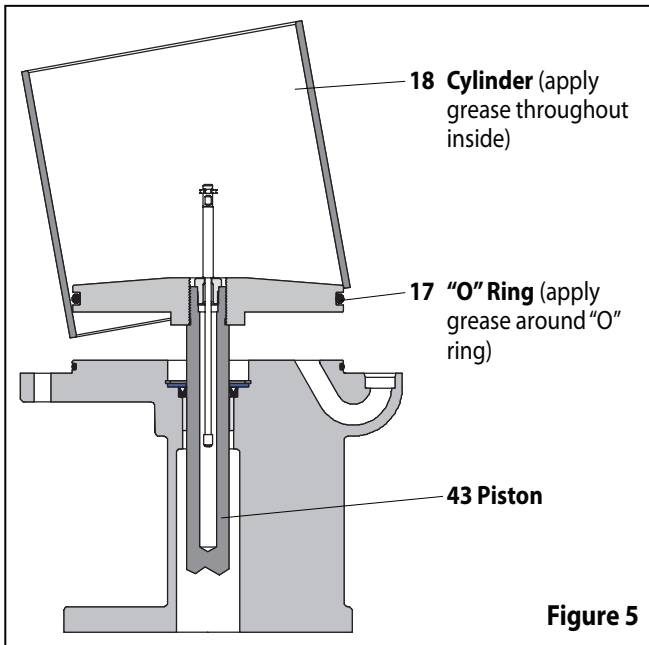

Figure 5

23. Bend the (39) seal in a heart shape and install in the (7) upper gland inside the (38) "O" ring (see figure 6).

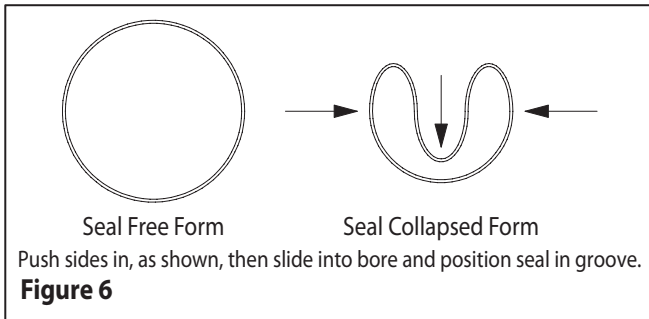

Figure 6

24. Grease and carefully push the (2) piston into the (7) upper gland to size the (39) seal and remove (see figure 7).

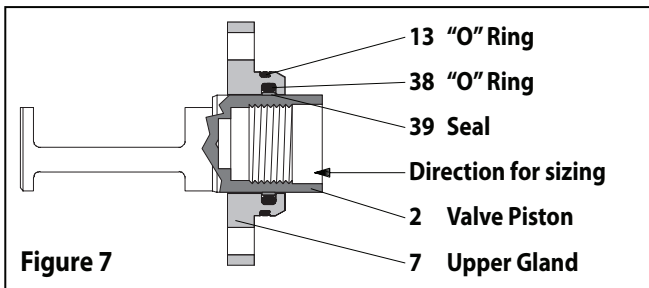

Figure 7

25. Place the (12) lower washer over the (11) extension rod.
26. Pull the (11) extension rod up and grasp with two fingers, (see figure 8).

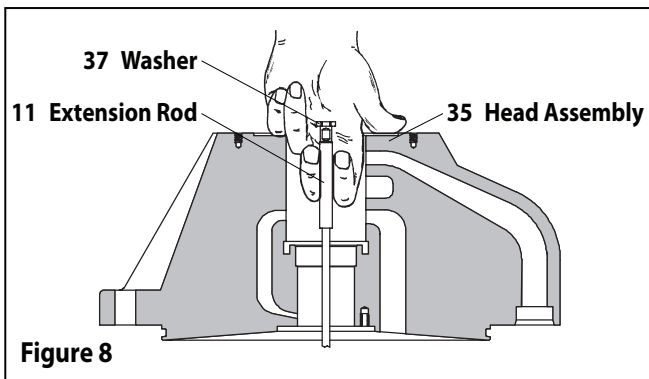

Figure 8

27. Place the 90350 installation tool over the (11) extension rod, with the turned diameter down and the chamfer up.
28. Fit the turned diameter of the 90350 installation tool into the bore in the bottom of the (35) head assembly.
29. Place the (10) adapter down over the (11) extension rod, with the threads upward.
30. Insert the (37) washer into the groove in the top of the (11) extension rod.
31. Pull the (10) adapter up and around the (37) washer.
32. Place the (8) upper washer over the (11) extension rod and onto the (10) adapter.
33. Clean the threads with solvent and put Loctite 271 on the threads of the (2) piston. Screw the (2) piston into the (10) adapter and tighten (see figure 3).
34. Push the assembled (10) adapter and (2) piston down through the 90350 installation tool until they bottom.
35. Remove the 90350 installation tool.
36. Install the (7) upper gland over the (2) piston and push down, being careful to retain the (39) seal in the "O" ring groove.
37. Align the two bolt holes and secure the (7) upper gland to the (35) head assembly with the two (47) screws and two (48) lock washers (see figure 2).
38. Insert the (28) spring in the (35) head assembly, with the hooks down and the nylon roller toward the (2) piston (see figure 2).
39. Thoroughly grease and insert the (3) pilot insert, two (4) valve guides, (5) valve plate and (6) gasket into the (35) head assembly (see figure 2).
40. Thoroughly grease and insert the (29) valve insert into the (35) head assembly (see figure 2).
41. Thoroughly grease and insert the (34) valve plate gasket and the (33) valve plate and pin assembly between the insert and the (35) head assembly, with the two pins in the (33) valve plate up (see figure 2).
42. Hook the round coils in the (28) insert spring assembly over the pins in the (33) valve plate and pin assembly (see figure 2).
43. Hook the bottoms of the (28) insert spring assembly into the holes on the side of the (33) valve plate and pin assembly (see figure 2).
44. Insert the (30) valve guide against the face of the (33) valve plate and pin assembly. The legs of the (30) valve guide should be down, with the leg having the threaded hole the farthest from the bottom toward the air inlet in the (35) head assembly.
45. Insert and tighten across corners the eight (45) screws and eight (46) washers (see figure 1).
46. Thoroughly grease and install the (32) gasket in the (31) cap.
47. Place the (31) cap on the (35) head assembly and secure with six (1) screws (see figure 4).