

Installation Instructions for Timken THS25 Encoder Tether

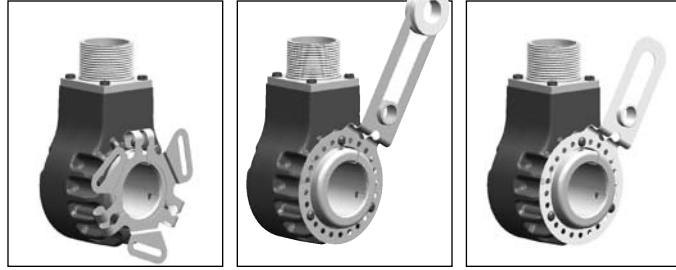

3 Point Flex Mount 8.5 in. C-Face Tether Arm 4.5 in. C-Face Tether Arm

Step 1

Ensure mating parts line up, bolt thread pitches and lengths are appropriate and tools are the correct type and size. Please refer to any additional motor manufacturer's installation instructions, as there may be some critical measurements or required hardware.

Step 2

Check and remove burrs on the mating shaft and measure to ensure the shaft length is correct for the encoder. The shaft should engage the encoder beyond the shaft clamp by $\frac{1}{2}$ in. or more. Attach the tether to the encoder body and slide the assembly onto the mating shaft. Do not tighten the shaft clamp on the encoder yet.

Step 3

Rotate the tether arm until it is at the correct orientation and is aligned with the mounting feature on the shaft housing. Use the appropriate hardware to secure the tether arm in position. Check to ensure the tether is still in its "unstressed" condition (move the encoder slightly if necessary). Tighten the shaft clamp on the encoder as shown in **Fig. A**.

Fig. A

Recommended Bolt Torques

THS25 Clamp Bolt
#6-32 Socket Head
Cap Screw
10 to 15 lb-in. $\frac{7}{64}$ in.

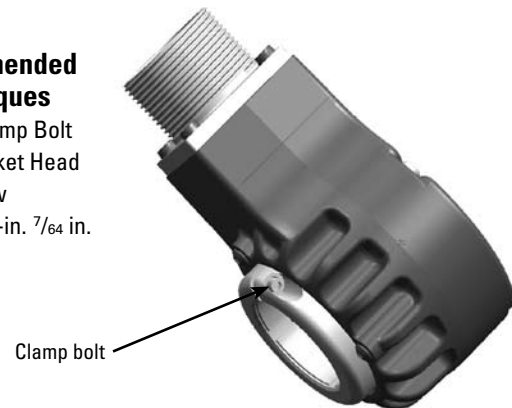

Step 4

Using a dial indicator on the outside of the encoder body, check the runout as you rotate the shaft by hand. If it exceeds the maximum allowable 0.005 in. the encoder will need to be re-installed or adjusted. The installation is complete.

CAUTION

Failure to observe the following cautions could cause property damage.

Excessive runout will cause premature bearing failure.

Installation Instructions for Timken THS25 Encoder using Block and Pin

Step 1

Ensure mating parts line up, bolt thread pitches and lengths are appropriate and tools are the correct type and size. Please refer to any additional motor manufacturer's installation instructions, as there may be some critical measurements or required hardware.

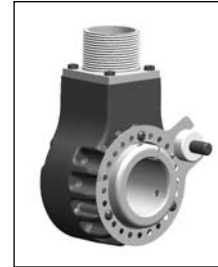

Block and Pin

Step 2

Drill a hole in the casing to accept the tether pin. Follow the motor manufacturer's instructions for diameter, depth and location of the hole. Make sure it is in the proper orientation relative to the tether block placement so that the finished installation will be "clocked" correctly. Insert the tether pin to the correct depth using a press fit. The pin depth should never exceed or interfere with the motor spinning mechanisms.

Step 3

Check and remove burrs on the mating shaft and measure to ensure the shaft length is correct for the encoder. Firmly attach the slotted tether to the encoder body and slide the assembly onto the mating shaft. Rotate the encoder body engaging the pin into the tether. Tighten the shaft clamp on the encoder as shown in **Fig. A**.

Step 4

Using a dial indicator on the outside of the encoder body check the runout as you rotate the shaft by hand. If it exceeds the maximum allowable 0.005 in. the encoder will need to be re-installed or adjusted. The installation is complete.

CAUTION

Failure to observe the following cautions could cause property damage.

Excessive runout will cause premature bearing failure.

Electrical Connection Information

Proper wiring and grounding are essential for the longevity and proper operation of your Timken THS25. In addition, electrical noise must be minimized to prevent improper counts and damage to the electronic components.

Because a Timken THS25 can be used with a wide variety of input devices (PLC's, counters, servo controllers, etc.), from many different manufacturers, it is important to determine proper wiring and connections before. Please review the Wiring Table included in these instructions before installation.

Common Signals

Timken THS25 encoders have the following electrical connections: Power, Common or Ground, and one or more Output Signals.

Power (Also called supply, power source, encoder power, +V, or +VDC)

- Always use a direct current (DC) voltage.
- Attach power to the positive (+) side of the power source.
- Verify the Timken THS25 is receiving the proper voltage. Most electrical failures are caused by an improper or improperly regulated power source.

NOTE

To avoid disabling or damaging the encoder, the use of surge protection is highly recommended.

Common (Also called Com, supply common, and ground)

- Attach common to the negative (-) side of the power source.

Output Signals (Always at least one, but may be as many as six)

- The common are A, B, and Z. with open collector configuration
- Encoders with a Line Driver output have the complement (A and A', B and B', etc.) as separate outputs. These are used to provide differential signals for reduced noise and greater drive capability.

NOTE

To avoid disabling or damaging the encoder, never connect the output signals together, or to the power source.

Connections

- Verify and match up pin numbers, wire colors, or terminal blocks with the input device.
- Be aware, identification terminology may not always be identical.
- Once proper wiring is determined, document it for future reference.

Cable Routing

- Cable length should be minimized by using the shortest route possible.
- All cabling should be installed in dedicated metal conduits, or located at least 12 in. away from other wiring.
- Route cables away from high current conductors to minimize pulses caused by electrical transients.
- Signal wire continuity should be maintained from the encoder to the controller/counter. Avoid junctions and splices, if possible.

TIMKEN
Where You Turn

THS25 Encoder Installation Instructions

Radiated Electrical Noise

- Ensure all equipment is properly grounded. (Motors, drives, shafts, etc.)
- Connect encoder cable shield to ground at controller/counter end, leaving the end near the encoder unconnected. Connecting the shield at both ends can cause ground loops, and improper operation.
- If possible, use differential line driver outputs with high quality shielded, twisted pair cable. (Complementary signals greatly reduce common mode noise levels, as well as signal distortion resulting from long cable lengths.)

Typical Electrical Hook-Ups

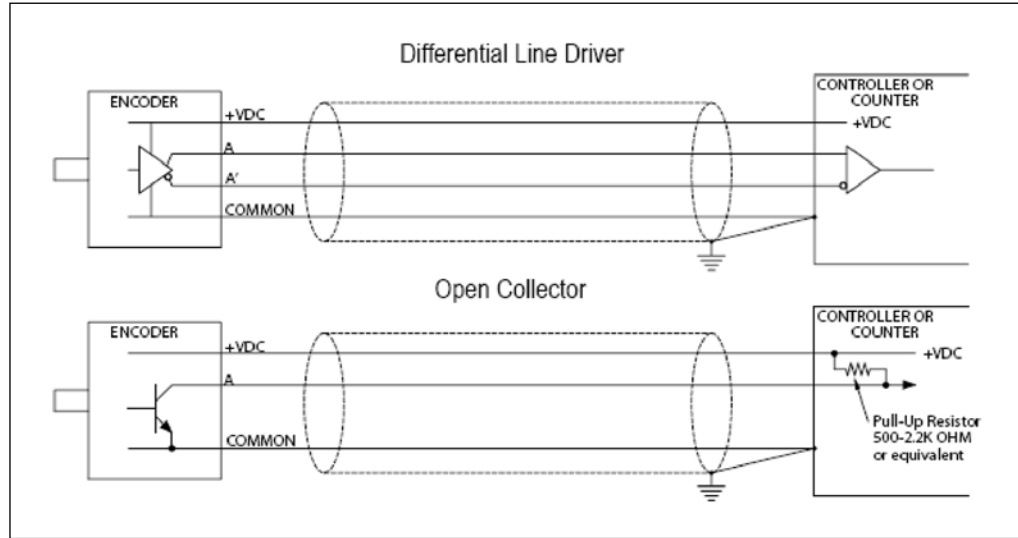

Output Circuit Diagrams

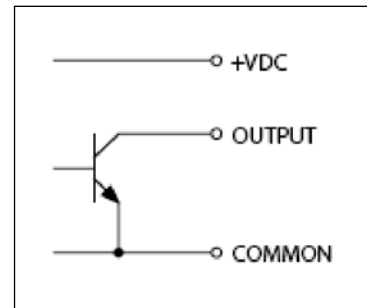

Open Collector

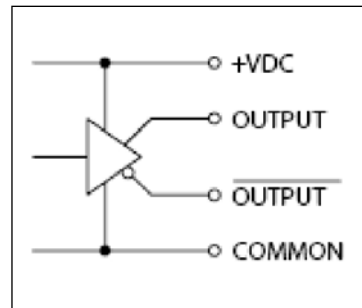

Line Driver

Every reasonable effort has been made to ensure the accuracy of the information contained in this writing, but no liability is accepted for errors, omissions or for any other reason.

Wiring Table

Function	Gland Cable Wire Color	5-pin M12	8-pin M12	10-pin MS	7-pin MS LD	7-pin MS OC	6-pin MS	10-pin Bayonet
Com	Black	3	7	F	F	F	A,F	F
+VDC	White	1	2	D	D	D	B	D
A	Brown	4	1	A	A	A	D	A
A'	Yellow	—	3	H	C	—	—	H
B	Red	2	4	B	B	B	E	B
B'	Green	—	5	I	E	—	—	J
Z	Orange	5	6	C	—	C	C	C
Z'	Blue	—	8	J	—	—	—	K
Case	—	—	—	G	G	G	—	G
Shield	Bare	—	—	—	—	—	—	—

ENCODER CONNECTOR CABLE ASSEMBLY WIRING

FUNCTION	STANDARD						TWISTED PAIR			M12 CORDSET			
	10 PIN MS		7 PIN MS		6 PIN MS		12 PIN		10 PIN MS	7 PIN MS	6 PIN MS	8 PIN	5 PIN
	LD	LD	LD	OC	LD	OC	LD	OC	LD	LD	LD	LD	OC
COM	Black	Black	Black	Black	Black	Black	Black	Black	Black	Black	Black	Blue	Blue
+VDC	Red	Red	Red	Red	Red	Red	Red	Red	Red	Red	Red	Brown	Brown
A	White	White	White	Orange	White	White	White	White	White	White	White	White	Black
A'	Brown	Brown	----	White	----	Brown	----	Black	Black	Black	Black	Green	----
B	Blue	Blue	Blue	Green	Green	Blue	Blue	Blue	Blue	Blue	Blue	Yellow	White
B'	Violet	Violet	----	Blue	----	Violet	----	Black	Black	Black	Black	Gray	----
Z	Orange	----	Orange	----	Orange	Orange	Orange	Yellow	----	----	----	Pink	Gray
Z'	Yellow	----	----	----	----	Yellow	----	Black	----	----	----	Red	----
Case	Green	Green	Green	----	----	Green	Green	Green	Green	----	----	Bare*	Bare*
Shield	Bare	Bare	Bare	Bare	Bare	Bare	Bare	Bare	Bare	Bare	Bare	Bare	Bare
Com Sense	----	----	----	----	----	Gray	Gray	----	----	----	----	----	----
+VDC Sense	----	----	----	----	----	Pink	Pink	----	----	----	----	----	----

*Only on specified cordsets

Troubleshooting

No Output/No Counts

- If there is no mechanical movement, there will be no output. Therefore, verify that the Timken THS25 is rotating.
- Check to make sure the proper supply voltage is present. It is best to do this at the Timken THS25 end, if possible.
- Verify all wiring between the Timken THS25, the counter/controller, and the power supply.
- Make sure the proper signal type (OC, LD) is being used for the application.
- Verify the counter/controller is properly installed and operational. Consult the appropriate counter/controller User's Manual if necessary.
- If another Timken THS25 is available, try it to determine if the encoder is the problem.

Erratic Output/Missing or Extra Counts

- **Electrical:** Check for loose wiring connections, ground loops, encoder outputs incompatible with the counter/controller, a noisy power supply, electrical noise, proper termination of shields, or a combination of these problems.
- **Mechanical:** Check for improper alignment or loose coupling. Counts indicate wrong direction
- Check for reversed wiring of the quadrature signals. Reverse if needed.
- If differential signals are being used, make sure both sides are properly wired.

NOTE

If an index pulse is being used, reversing the wiring will cause the reference alignment to change.

Counts In Only One Direction

- Make sure the counter/controller is capable of, and programmed for, bi-directional counting.
- On quadrature units, both channels (A and B) must be present and operational. Check by using a dual channel oscilloscope.
- Make sure the input selection type programmed into the counter/controller, matches the Timken THS25. If there is a mis-match, the system may not work properly.

Index Pulse Not Working

- The index pulse occurs only once per revolution, and can be difficult to check with a volt meter. Check index pulses with an oscilloscope.
- The counter/controller may not be capable of detecting the index pulse at higher RPM's. Slowing down the rotation may allow for detection of the index pulse.
- Verify wiring.

TIMKEN
Where You Turn

www.timken.com

Timken® is a registered trademark of The Timken Company

© 2009 The Timken Company
Printed in U.S.A.
5M 07-09-29 Project No. 0661