FCC STATEMENT

This device complies with Part 15 of the FCC Rules. Operation is subject to the following two conditions:

- (1) This device may not cause harmful interference, and
- (2) This device must accept any interference received, including interference that may cause undesired operation.

Note:

This equipment has been tested and found to comply with the limits for Class B digital devices, pursuant to Part 15 of the FCC rules. These limits are designed to provide reasonable protection against harmful interference in a residential installation. This equipment generates uses and can radiate radio frequency energy and, if not installed and used in accordance with the instructions, may cause harmful interference to radio communications.

However, there is no guarantee that interference will not occur in a particular installation. If this equipment does cause harmful interference to radio or television reception, which can be determined by turning the equipment off and on, the user is encouraged to try to correct the interference by one or more of the following measures:

- Reorient or relocate the receiving antenna
- Increase the separation between the equipment and receiver
- Connect the equipment into an outlet on a circuit different from that to which the receiver is connected

Use of shielded cable is required to comply with Class B limits in Subpart B of Part 15 of the FCC rules.

Do not make any changes or modifications to the equipment unless otherwise specified in the manual. If such changes or modifications should be made, you could be required to stop operation of the equipment.

READ THIS FIRST

1. Product design and specifications are subject to change without notice. This includes primary product specifications, software, software drivers, and user's manual. This User Manual is a general reference guide for the product.
2. The product and accessories that come with your camera may be different from those described in this manual. This is due to the fact that different retailers often specify slightly different product inclusions and accessories to suit their market requirements, customer

demographics, and geographical preferences. Products very often vary between retailers especially with accessories such as batteries, chargers, AC adapters, memory cards, cables, carrying cases/pouches, and language support. Occasionally a retailer will specify a unique product color, appearance, and internal memory capacity. Contact your dealer for precise product definition and included accessories.

3. The illustrations in this manual are for the purpose of explanation and may differ from the actual design of your camera.
4. The manufacturer assumes no liability for any errors or discrepancies in this user manual.
5. For driver updates, you can check the "Download" section of our website, www.geniusnet.com.tw.

WARNING

- Do not use this camera if it is emitting smoke (or an unusual odor), if it becomes unusually hot to the touch, produces a peculiar noise, or exhibits any other abnormal conditions. Operating the camera in any of these circumstances may cause a fire or an electrical shock. Stop using the camera immediately, turn the camera off and remove the battery. Contact your dealer or authorized service facility for repairs. Never attempt to repair this camera by yourself, as this may be dangerous.
- Do not expose the camera to moisture and make sure no water gets into the camera. Take particular care when using the camera under extreme weather conditions, such as rain or snow, or when operating the camera at the beach or near water. Avoid using this camera in places subject to extreme moisture. Do not use the camera if water has entered the camera. Turn the camera off and remove the battery. Contact your dealer or authorized service facility. Do not continue to use the camera as this may cause a fire or an electrical shock.
- Do not use the camera if any foreign objects have entered the camera. Turn the camera off and remove the battery. Contact your dealer or authorized service facility. Do not continue to use the camera as this may cause a fire or an electrical shock.
- Do not place the camera in an unstable location such as on a wobbly table or sloping surface where the camera may fall or tip over and cause injury. If the camera has been dropped or damaged, turn the camera off and remove the battery. Contact your dealer or authorized service facility. Do not continue to use the camera as this may cause a fire or an electrical shock.
- Do not insert or drop metallic or other foreign objects into the camera through access points such as the memory card slot. This may cause a fire or an electrical shock.
- Do not attempt to modify this camera. Do not remove the camera casing. This may cause a fire or an electrical shock. Internal inspection and repairs should only be carried out by an

authorized service facility.

- Never operate this camera in any way while driving a vehicle. This may cause a traffic accident.
-

CAUTION

- Do not place this camera in a location affected by oil fumes or steam, such as near a cooking stove or humidifier. This may cause a fire or an electrical shock.
 - Do not leave this camera in a location subject to extremely high temperatures, such as in a sealed vehicle or in direct sunlight. Exposure to high temperatures may adversely affect the camera case and internal components and may cause a fire.
 - Do not cover or wrap the camera with a cloth or quilt. This may cause heat to build up and distort the camera case and cause a fire. Always use the camera and accessories in well-ventilated locations.
 - Handle the camera carefully and do not expose the camera to shock or vibration. Handling the camera roughly may cause a malfunction.
 - Do not use battery other than those specified for use with your camera. Use of unsuitable battery may result in the battery splitting, or leaking and may cause a fire, injury, or soiling of the battery compartment.
 - When placing the battery into the camera, check the polarity markings on the battery (- and +) to ensure that the battery is inserted correctly. Incorrect battery polarity will result in camera inoperability and may result in the battery splitting or leaking and causing a fire, injury, or soiling of the battery compartment.
 - Remove the battery if the camera will not be used for an extended period of time. The battery may leak and cause a fire, injury or soiling of the battery compartment. If the battery leaks, clean and wipe the battery compartment carefully and install a new battery. Wash your hands carefully if you touch the battery fluid.
-

CONTENTS

INTRODUCTION 6-7

- Overview
- Package contents

GETTING TO KNOW THE

CAMERA 8-15

- Front view
- Rear view
- Mode dial
- Viewfinder LED indicators
- LCD monitor information

GETTING STARTED 16-22

- Attaching the Camera Strap
- Inserting and Removing the Battery
- Charging the Battery
- Inserting and Removing the SD Card
- Turning the Power On/Off
- Formatting the SD Card
- Choosing the Language
- Setting the Date and Time
- Setting Image Resolution and Quality

PHOTOGRAPHS MODE 22-35

- [**A**] **Auto Photography Mode**
 - Using the Optical Zoom
 - Using the Digital Zoom
 - Setting the Flash
 - Setting the Focus
 - Self-timer/Photographing at Intervals
 - Exposure Compensation/Backlight Correction
- [**P**] **Program (Automatic Exposure)**

Photography Mode

- [**Tv**] **Shutter Speed Priority**

Photography Mode

- [**Av**] **Aperture Priority Photography Mode**

- [**M**] **Manual Photography Mode**
Setting the Scene Mode

- [] **Movie Mode**

[] **PLAYBACK MODE 36-45**

- Playing Back Still Images
- Playing Back Video Clips
- Playing Back Still Images/Video Clips on a TV
- Recording Voice Memos
- Thumbnail Display
- Zoom Playback
- Slideshow Display
- Protecting Images
- DPOF Settings
- [] Erasing Images

MENU OPTIONS 45-54

- Photography Menu (Picture)
- Photography Menu (Function)
- Photography Menu (AE/AWB)
- Playback Menu
- Setup Menu (Basic)
- Setup Menu (Custom)

TRANSFERRING RECORDED IMAGES/MOVIES TO YOUR

COMPUTER 54-56

- Step 1: Installing the USB Driver
- Step 2: Connecting the Camera to Your Computer

Step 3: Downloading Images and Video

Files

INSTALLING**Presto! Mr. Photo.....56-57****INSTALLING****Presto! Image Folio.....57****CONNECTING THE
CAMERA TO OTHER****DEVICES.....58****CAMERA****SPECIFICATIONS.....58-59**

INTRODUCTION

Overview

Congratulations on your purchase of the new digital camera.

Capturing high-quality digital pictures is fast and easy with this state-of-the-art smart camera.

Equipped with a 6.3 Mega pixel CCD, this camera is capable of capturing pictures with a resolution of up to 2816 x 2112 pixels.

Other cool features provided by the camera include the following:

- LCD monitor –** The 2.0" CG silicon color LCD monitor makes it easy to frame your subject when taking pictures. It also displays the pictures you have taken.
- Recording medium –** External memory supports SD card up to 512MB.
- Camera mode –** Variety of camera modes allows you to operate for your preference and take photographs according to photographic condition.
- Optical zoom –** 3x optical zoom lens allows you to take telephoto and wide-angle pictures.
- Digital zoom –** 4.4x digital zoom and 3x optical zoom permit zoom photography of up to 13.2 times; 2x and 4x playback captured images to enlarge a selected portion of an image.
- Flexible flash settings –** Change the flash setting according to your lighting environment and photography mode setting.
- Focus mode –** Photographs can be taken with the distance to the subject set by auto focus, macro, infinity, 3 m, or 1 m.
- Self-timer mode –** Time selectable between 2 seconds, 10 seconds, 10+2 seconds and interval.
- Still image capture** Take different still images including single, a series of 3 images with different exposures, and 5 images continuously.
- Movie mode –** Record video clips with voice.
- Voice memo –** A voice memo can be recorded for 5 seconds immediately following still single image photography. Also it can be recorded while viewing the picture in playback mode.
- Camera settings –** Have more control over picture quality by adjusting the menu options.

- Thumbnail display** – Display in sets of nine pictures on the LCD for easier and quicker selection of pictures.
- TV and PC connection** – View pictures on a television monitor or computer while connected to the USB or A/V cable.
- DPOF settings** – Allow you to embed printing information on your SD card and to print your images on a DPOF compatible printer by simply inserting it.

Package contents

Carefully unpack your package and make sure that you have the following items. In the event that any item is missing or if you find any mismatch or damage, promptly contact your dealer.

- Digital camera
- Video cable
- User's manual
- Quick guide
- Two Rechargeable Lithium Ion Batteries
- Rechargeable Lithium Ion Battery Charger
- AC Plug Adaptor for EU to US
- USB cable
- Software CD-ROM
- Camera strap
- Camera pouch
- A 32MB SD memory card
- Rechargeable Lithium Ion Battery Charger Power Cord



NOTE

- Accessory and components may vary by different retailer.

GETTING TO KNOW THE CAMERA

Front view

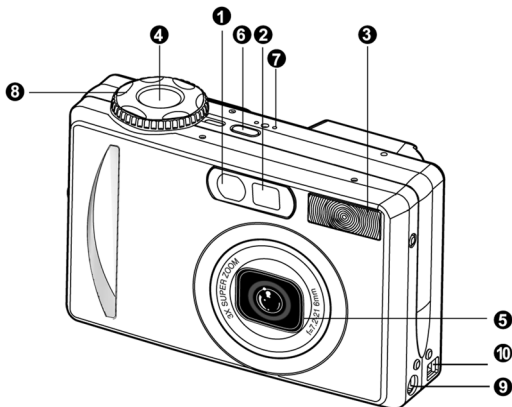

#	Name	Description
1.	Self-timer LED (AF auxiliary light)	Blinks red during Self-timer mode until picture is taken. Effective for still image capture mode when the luminance value of Auto and Macro focus mode is below 6.
2.	Viewfinder window	Allows you to frame the subject of the picture.
3.	Flash	Provides flash illumination.
4.	Shutter button	Focuses and locks the exposure of the camera when pressed halfway down, and takes the picture when pressed all the way down.
5.	Zoom lens	3X optical zoom lens allows you to take telephoto and wide-angle pictures.
6.	POWER button	Turns the camera power on and off.
7.	MIC (Microphone)	Records audio clips.
8.	Mode dial	Sets the camera mode.
9.	DC IN 5V terminal	Allows you to connect AC power adapter to the camera to operate the camera without battery, or to charge rechargeable battery.
10.	USB/A/V OUT terminal	Allows you to connect a USB cable or an A/V cable to the camera.

Rear view

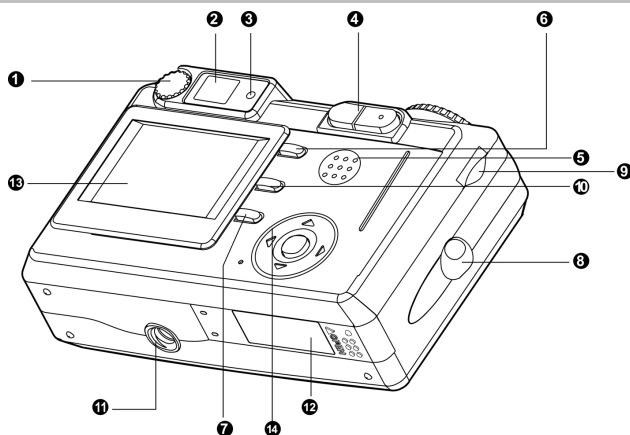

#	Name	Description
1.	Diopter adjustment dial	Provides a more clear image when using the viewfinder.
2.	Viewfinder window	Allows you to frame the subject of the picture.
3.	Viewfinder LED	Displays the camera current state.
4.	(Zoom in) button (Zoom out) button	Zooms the lens to telephoto position. Zooms the lens to wide-angle position.
5.	Speaker	Produces camera sounds and plays recorded audio.
6.	MENU button	Toggles OSD menu on and off.
7.	(Display) button	Turns the LCD monitor display and live view on and off.
8.	Strap holder	Camera strap attachment.
9.	Search dial	Selects the next or previous picture in playback mode, or changes the shutter speed or aperture value setting in [Tv] , [Av] and [M] modes.
10.	(Erase) button	Allows you to erase the picture.
11.	Tripod socket	Allows tripod mounting.
12.	Battery/SD card cover	Allows access to the battery and insert or remove the memory card.
13.	LCD monitor	Provides menu information to operate the camera, and previews the picture before taking it and review it afterwards.
14.	SET /Direction button	Allows you to scroll through menus and pictures, and then select choices.

SET /Direction button

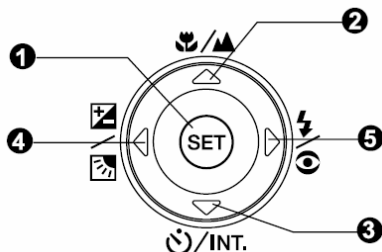

#	Name	Description
1.	SET button	Enters the menu page and confirms the chosen setting.
2.	▲ button	Scrolls upwards.
3.	⬇/▲ (Focus) button	Allows you to choose the appropriate focus setting.
4.	▼ button	Scrolls downwards.
5.	⌚/INT. (Self-timer) button	Allows you to toggle the self-timer on and off, selects the desired self-timer mode or choose the interval photography.
6.	◀ button	Scrolls left.
	⊞/⊞ (Exposure compensation / Backlight correction) button	Allows you to toggle the exposure compensation / backlight correction on and off.
7.	▶ button	Scrolls right.
	⚡/⌚ (Flash) button	Allows you to choose the appropriate flash setting.

Mode dial

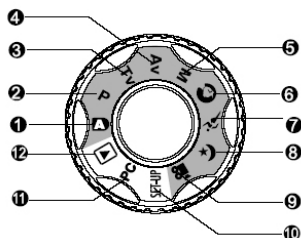

A : photography mode

#	Mode	Description
1.	A Auto photography	The camera is automatically sets for exposure, etc.
2.	P Program (auto exposure)	This permits the shutter speed and aperture to be set automatically and other factors to be set manually.
3.	TV Shutter speed priority	Selects this when you want to photograph with shutter speed priority.
4.	AV Aperture priority	Selects this when you want to photograph with aperture priority.
5.	M Manual photography	Selects this when you want to manually set the exposure, aperture and other settings.
6.	P Portrait	Selects this when you want to photograph a person and blur the background.
7.	S Sports	Selects this when photographing fast-moving subjects.
8.	N Night scene	Selects this when photographing evening or night scenes.
9.	M Movie	Selects this when recording video clips.
10.	SET-UP Set-up	Chooses your preferences on the camera's settings.
11.	PC PC	Downloads the image to the personal computer.
12.	P Playback	Performs image playback, deletion and writing of the print information.

Viewfinder LED Indicator

This describes the color and state of the viewfinder LED.

Color	State	During power off	During photography	During playback	During connection to a PC
Green	On	Battery charging in progress.	Auto focusing successful. (AF is locked)	-	While the camera is connected to a PC.
	Flashing	-	Self-timer in operation at a handshake alarm.	-	USB busy
Red	On	-	Writing to SD card in progress	Accessing of SD card in progress. DPOF file is being created.	Accessing of SD card in progress.
	Flashing	-	Auto focusing failure	-	-
Orange	On	Battery charging error.	Processing image. Flash charging in progress. Zoom initialization in progress.	-	Not recognized by the PC, or other status.
	Flashing	-	No battery power left. Camera malfunction.	No battery power left.	No battery power left. No SD card.

LCD Monitor Icons

Photography mode [**A**] [] [] []

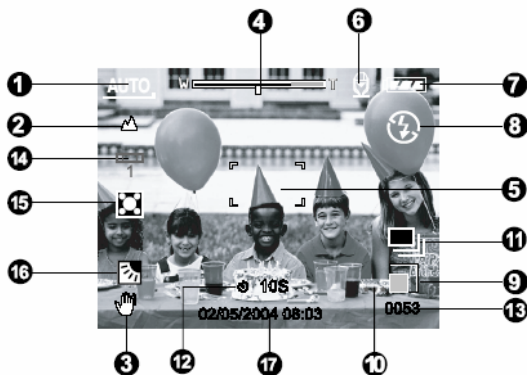

- | | |
|---|------------------------------|
| 1. Mode icon | 9. Image size |
| 2. Focus icon | 10. Quality |
| 3. Unsteady hold warning icon | 11. Capture mode icon |
| 4. Zoom status | 12. Self-timer icon |
| 5. Focus area (When the shutter button is pressed halfway.) | 13. Possible number of shots |
| 6. Voice memo | 14. White balance icon |
| 7. Remaining battery status | 15. Metering icon |
| 8. Flash icon | 16. Backlight correction |
| | 17. Date and time |



NOTE

- Each press of the  button switches one step in the sequence of Normal display (displaying the icons, etc), display OFF, LCD monitor OFF.

Photography modes [P] [Tv] [Av] [M]

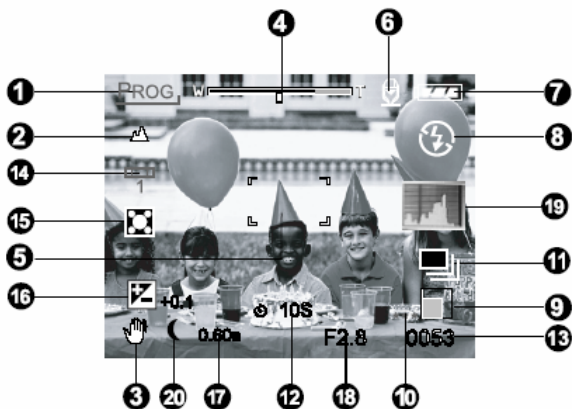

- | | |
|---|----------------------------------|
| 1. Mode icon | 11. Capture mode icon |
| 2. Focus icon | 12. Self-timer icon |
| 3. Unsteady hold warning icon | 13. Possible number of shots |
| 4. Zoom status | 14. White balance icon |
| 5. Focus area (When the shutter button is pressed halfway.) | 15. Metering icon |
| 6. Voice memo | 16. Exposure compensation |
| 7. Remaining battery status | 17. Shutter speed |
| 8. Flash icon | 18. Aperture |
| 9. Image size | 19. Histogram |
| 10. Quality | 20. Long time exposure mode icon |

**NOTE**

- Each press of the  button switches one step in the sequence of Normal display (display the icons, etc), Normal and Histogram display, display OFF, LCD monitor OFF.

Photography mode []

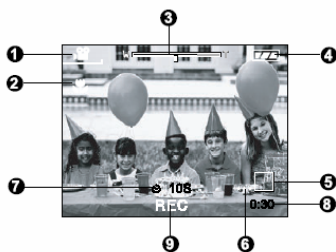

1. Mode icon
2. Focus icon
3. Zoom status
4. Remaining battery status
5. Image size
6. Quality
7. Self-timer icon
8. Possible recording time/elapsed time
9. Recording indicator

Playback mode []-Still Picture Playback



1. Folder number
2. File number
3. Voice memo icon
4. Protect icon
5. Mode icon

Playback mode []-Video Playback

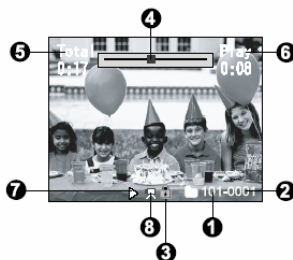

1. Folder number
2. File number
3. Protect icon
4. Movie status bar
5. Total time
6. Elapsed time
7. Play mode
8. Mode icon

GETTING STARTED

Attaching the Camera Strap

Attach the camera strap as shown in the illustration.

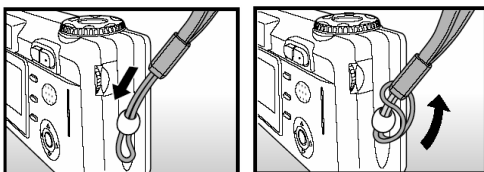

Inserting and Removing the Battery

We highly recommend using specified rechargeable lithium-ion battery to fully demonstrate this camera's function. Charge the battery before using the camera. Make sure that the power of the camera is off before inserting or removing the battery.

1. Open the battery/SD Memory Card cover.
2. Insert the battery in the correct orientation shown.
 - Tilt the battery lock lever in the direction of the arrow and orient the battery so that its label is facing to the front side of the camera, and then insert the battery.
3. Close the battery/SD Memory Card cover.

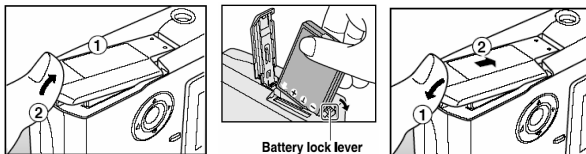

Removing the Battery

Open the battery/SD card cover and then release the battery lock lever. When the battery has come out a little, slowly pull it out the rest of the way.



NOTE

- Use only the specified battery type (Lithium Ion).
- If you are not going to use the battery for an extended period of time, remove it from the camera to prevent leakage or corrosion.
- Never use different type of battery.
- Avoid using battery in extremely cold environments as low temperatures can shorten the

battery life and reduce the camera performance.

Charging the Battery

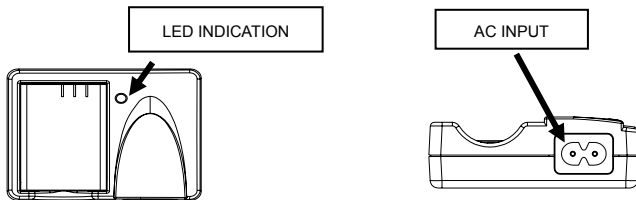

1. Insert the battery, noting correct polarity (+ and -).
Input Voltage:100-240V/50-60Hz
Output Voltage:4.2V/750mA

2. LED Indicator:

Status	LED Indication	Battery Charge Condition
Battery not installed	Green	OK
Battery installed	Green	Fully charged
Battery installed	Red	Charging
Battery installed/not installed	Off	Battery/charger defective

3. Notice:
 - A. Before you use a new battery, it should be charged for 3 hours the first time.
 - B. If the green LED is on when power is connected, it indicates the battery charger is operating normally and ready for battery charging.
 - C. When the battery is put into the battery charger, the LED indicator changes from green to red, indicating the battery is being charged.
 - D. If the LED indicator is not on when the power is connected, it indicates that the battery charger is defective. The user should turn AC power off.
 - E. If the battery has been charged over 3 hours and the LED indicator is still red, this means the battery is faulty. The user should remove the battery.
 - F. If it is necessary to charge a backup battery, the user should wait until the charging battery is completely charged. Then remove the charged battery and charge the backup battery.



NOTE

- Never use the battery unspecified for the camera.
- Do not place the camera in hot temperature. Use it at room temperature.

Inserting and Removing the SD Card (Optional)

Images photographed with this camera will be stored on the SD card. Without inserting the SD card, you cannot take photographs using the camera. Before inserting or removing the SD card, make sure that the power of the camera is off. You may also expand the memory capacity up to 512MB so that you can store additional images and video clips.

Inserting the SD card

1. Slide the battery/SD Memory Card cover in the direction of the [OPEN] arrow.
2. Insert the SD card in the correct orientation shown.
 - Hold the SD card with its metal contact end surface facing the rear side of the camera, and then insert the card as far as it can go.
 - If the card cannot be inserted, check the orientation.
3. Close the battery/SD Memory Card cover.

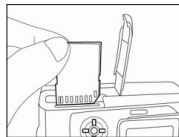

Removing the SD card

Open the battery/SD card cover, press lightly on the edge of the SD card and it will eject.



NOTE

- If the camera is powered-on without the card, the "NO CARD" message appears on the LCD monitor.
- To prevent valuable data from being accidentally erased from an SD Memory Card you can slide the write-protected tab (on the side of the SD Memory Card) to "LOCK".
- To save, edit or erase data on an SD Memory Card, you must unlock the card. MMC Card can not be accepted to use.
- Please format an SD Memory Card by this camera before use.

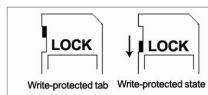

Turning the Power On/Off

Load the battery and insert an SD card before starting.

Turning the power on

Press the **POWER** button to turn the power on.

- The viewfinder LED lights green and the camera is initiated.
- When the power is turned on, the camera will start in the mode that was set with the mode dial.

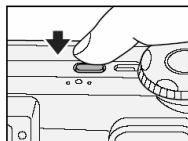

Turning the power off

Press the **POWER** button to turn the power off.



NOTE

- The power is turned off automatically when the camera has not been operated for a fixed period time. To resume the operation condition, turn the power on again. Refer to section in this manual titled "**Auto PoFF**" in the **Setup Menu (Basic)** for further details.
- After the power is turned on, it may take several seconds to charge the flash. While the flash is being charged, the viewfinder LED lights orange, and then the camera is not yet ready for photography. Start photography after the viewfinder LED is turned off.

Formatting the SD Card

This erases all of the images and folders that have been recorded on the SD card. Formatting is not possible when the SD card is in the locked condition.

1. Set the mode dial to [SET-UP].
 - [Basic] of the set-up menu is displayed.
2. Select [Format] with the ▲ / ▼ buttons from [Basic] of the set-up menu, then press the **SET** button.
3. Select [Execute] with the ▲ / ▼ buttons, and press the **SET** button.
 - To cancel formatting, select [Cancel] and press the **SET** button.

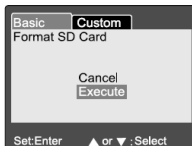
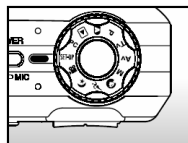

NOTE

- You need to format an SD card before using it in this camera.
- Formatting the SD card also erases the protected images. All data other than images are also erased. Before formatting the card, make sure that all the images are unnecessary.

- Formatting is an irreversible action and data cannot be recovered at a later time.
- An SD card having any problem cannot be properly formatted.

Choosing the Language

When you first turn the camera on, choose a language for displayed information on the LCD monitor.

1. Set the mode dial to [SET-UP] and press the ► button
 - [Custom] of the set-up menu is displayed.
2. Select [Language] with the ▲ / ▼ buttons and press the SET button.
 - The Language setting screen will be displayed.
 - Select the displayed language using the / buttons and press the SET button. The setting will be stored.

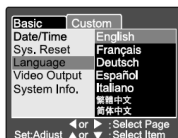
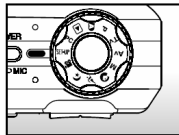

Setting the Date and Time

The date/time needs to be set if/when:

- Camera is turned on for the first time.
- Camera is turned on after leaving the camera without the battery for an extended period of time.

When the date and time information is not displayed on the LCD monitor, follow these steps to set the correct date and time.

1. Set the mode dial to [SET-UP] and press the ► button.
 - [Custom] of the set-up menu is displayed.
2. Select [Date/Time] with the ▲ / ▼ buttons and press the SET button.
 - The Date/Time setting screen will be displayed.
3. Select the item's field with the ◀ / ▶ buttons and adjust the value for the date and time with the ▲ / ▼ buttons.
4. After confirming all settings are correct, press the SET button.
 - The setting will be stored and the screen will return to the

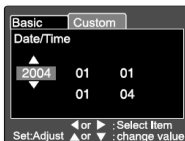
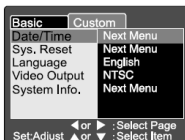
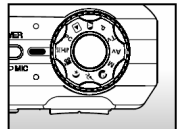

set-up menu.

- The date and time is set in the order year-month-day-hour-minute.

Setting Image Resolution and Quality

Resolution and quality settings determine the pixel size (dimension), image file size, and compression ratio for your images. These settings affect the number of images that can be stored in memory, or on a memory card. As you get to know the camera, it is recommended that you try each quality and resolution setting to get an appreciation for the effects that these settings will have on your images.

Higher resolution and higher quality images offer the best photographic results but produce large files sizes. Therefore, few images will take up a lot of memory space.

High resolution and quality settings are recommended for printed output and situations requiring the finest detail. Lower resolution/quality images take up less memory space and may be quite suitable for sharing images via e-mail, in a report, or on a web page.

To change image resolution or image quality, perform these steps below:

1. Set the mode dial to one of the photography modes.
2. Press the **MENU** button.
 - [Picture] of the photography menu is displayed.
3. Select [Size] with the ▲ / ▼ buttons, and press the **SET** button.
4. Select the desired setting with the ▲ / ▼ buttons, and press the **SET** button.
5. Select [Quality] with the ▲ / ▼ buttons, and press the **SET** button.
6. Select the desired setting with the ▲ / ▼ buttons, and press the **SET** button.
7. To exit from the photography menu, press the **MENU** button.



Possible number of shots (Still picture)

The table shows the approximate shots that you can take at each setting based on an optional SD card from 32MB to 512MB.

Image size	Quality	SD Card				
		32MB	64MB	128MB	256MB	512MB
 (6M) 2816 x 2112	★★★ (Fine)	11	22	45	91	183
	★★ (Standard)	18	38	77	154	311
	★ (Economy)	34	70	142	283	571

	TIFF	2	5	10	21	43
 (4M) 2272 x 1704	★★★ (Fine)	18	37	76	151	305
	★★ (Standard)	30	61	124	247	498
	★ (Economy)	59	121	244	487	981
 (2M) 1600 x 1200	★★★ (Fine)	37	76	153	306	616
	★★ (Standard)	59	121	244	487	981
	★ (Economy)	118	242	489	975	1963
 (VGA) 640 x 480	★★★ (Fine)	145	298	602	1200	2417
	★★ (Standard)	210	430	870	1734	3491
	★ (Economy)	379	775	1566	3121	6284

Possible recording time/sec (Video clip)

Image size	Quality	SD Card				
		32MB	64MB	128MB	256MB	512MB
 320x240	★★★ (Fine)	01:45	03:34	07:13	14:23	28:59
	★★ (Standard)	02:36	05:20	10:46	21:28	43:13

* The data shows the standard testing results. The actual capacity varies according to the shooting conditions and settings.



NOTE

- The memory card testing results for 512MB are based on Toshiba, Panasonic and Sandisk SD card.

PHOTOGRAPHY MODE

[] Auto Photography Mode

Auto photography is a typical method of photography. Photographs can be taken simply

because the exposure (the combination of shutter speed and aperture setting) is controlled automatically to suit the photographic conditions. You can use both a viewfinder and a 2.0" LCD monitor to compose the images. Taking photographs using the viewfinder will conserve the battery power. If the battery power is low, it is recommended that you only compose images using the viewfinder. Using the LCD monitor, you can compose images more accurately, but at the cost of the battery consumption.

Using the Viewfinder

Make sure that the battery is inserted before taking photographs.

- Press the **POWER** button to turn the power on.
- Set the mode dial to [**A**].
- Compose your shot in the viewfinder.
 - Turn the "diopter adjustment dial" until the image appears clearly within the viewfinder.
- Press the shutter button.
 - Pressing the shutter button down halfway automatically focuses and adjusts the exposure, and pressing the shutter button down fully takes the photographs.
 - The focus area frame turns blue and the viewfinder LED lights green when the camera is in focus and the exposure is calculated.
 - When the focus or exposure is not suitable, the frame of the focus area turns yellow and the viewfinder LED flashes red.
 - If the photographic preview is set to "ON", the preview image (captured image) will be displayed while the image is being recorded onto the memory.
 - When the voice memo is set to "ON", [VOICE RECORDING] will be displayed on the screen immediately after the photography, and the voice memo recording will start.
 - Press the shutter button one more time during recording, or wait for 30 seconds,

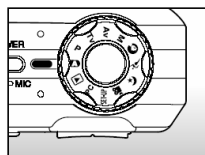

Diopter adjustment dial

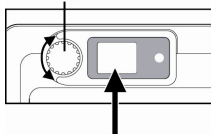

① Press down halfway.

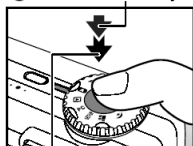

② Press down fully.

[VOICE RECORD END] will be displayed and the recording will end. A [] icon is displayed with images that have been recorded with a voice memo.



NOTE

- Voice memo is starting to record at still image capture mode just after the photograph is taken in case of activating this function. It provides 30 seconds for recording and only can be done once. To terminate recording, press the shutter button down fully.

Using the LCD Monitor

Make sure that the battery is inserted before taking photographs.

1. Press the **POWER** button to turn the power on.
2. Set the mode dial to [**A**].
 - By default, the LCD monitor setting is "ON".
3. Compose the picture in the LCD monitor.
4. Press the shutter button down halfway (the camera adjusts the exposure and the focus), then press it down fully.
 - The viewfinder LED indicator lights red while the camera is processing a captured image.

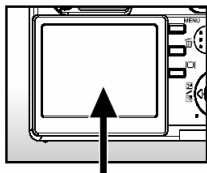

LCD Monitor Display (Capture Mode)

The [**DISP**] Display button can select display format. Whether in "Still Image" or "Movie" mode, preview image with full OSD is displayed.

OSD (on-screen-display) full display → OSD display OFF → LCD monitor OFF



NOTE



- The image in the LCD monitor darkens in strong sunlight or bright light. This is not a malfunction.
- Using the LCD monitor for an extended period of time will decrease the number of images you can take. To increase the shots and conserve battery power, it is recommended to turn the LCD monitor off and use the viewfinder instead.

Using the Optical Zoom

Zoom photography allows you to take zoom photographs up to 3 times the size or wide-angle photography depending on the distance up to the subject. You can also enlarge the center of the screen and take photographs in the digital zoom mode.

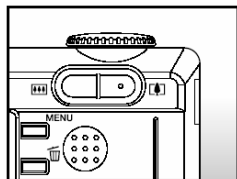















1. Set the mode dial to one of [**A**], [**P**], [**Tv**], [**Av**], [**M**], [**C**], [**z**], [*****], [**W**] and power on the camera.
2. If required, turn on the LCD monitor by pressing the







- [] button.
- Compose the picture with the zoom button.
 - Pressing the [] button zooms in on the subject, and enlarges the subject on the LCD monitor.
 - Pressing the [] button provides a wider angle picture.
 - The lens position moves according to the zoom button setting.
 - Press the shutter button down halfway, and then press it down fully.

Using the Digital Zoom

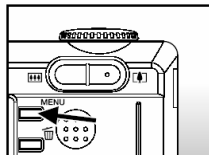
Using a combination of 3 times optical zoom and 4.4 times digital zoom permits zoom photography of up to 13.2 times to suit the subject and the distance. The digital zoom is a compelling feature, the more an image is enlarged (zoomed), and the more pixilated (grainer) the image will appear.

- Set the mode dial to one of [, [, [, [, [, [, [, [, [] and power on the camera.
- If required, turn on the LCD monitor by pressing the [] button.
- To enable the digital zoom is as follows:
 - Press the **MENU** button.
 - Select [**Function**] with the  or  buttons.
 - Select [Digital Zoom] with the  /  buttons, and press the **SET** button.
 - Select [ON] with the  /  buttons again, and press the **SET** button.
 - Press the **MENU** button to exit from the menu screen.
 - To activate the digital zoom, press the [] button completely and hold it until the image on the LCD monitor expands.
- Press the shutter button to capture a "zoomed" image.



Picture	Function	AE/AWB
Capture Mode	Single	
Voice Memo	ON	
LCD Bright.	+1	
Digital Zoom	ON	
Preview	OFF	
Date Print	OFF	
Interval/Count	Next Menu	
Menu:Exit	 or 	:Select Page
Set:Adjust	 or 	:Select Item

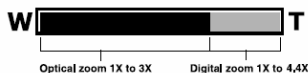

NOTE



- The digital zoom is cancelled when the [] button is pressed and the LCD monitor is

turned off.

- The zoom setting is automatically cancelled by either turning the camera off or the activation of the Auto Power Off function.

Using the Flash

Set the flash for taking photographs. The flash firing mode can be set to suit for the photographic conditions.



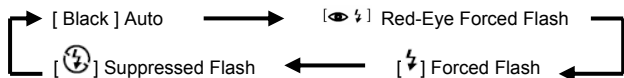



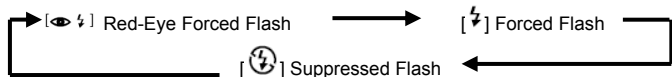

1. Set the mode dial to one of the photography modes.
 - The flash setting is limited depending on the selected photography mode, scene mode, and capture mode.
2. Toggle the  button to select the desired flash mode.
 - Each press of the  button moves the icon one step through the sequence and displays it on the screen.
 - For the mode of []:



- For the modes of [], [], [] and []:











Flash Mode	Description
[Black] Auto	The flash fires automatically to suit the photographic conditions. This is only effective when the camera is set to the [] mode.



<p>[] Red-Eye Reduction</p>	<p>Use this mode to reduce the red-eye phenomenon when you want to take natural-looking photographs of people and animals in low-light conditions.</p> <p>When taking photographs, the red-eye phenomenon can be reduced by asking the subject (person) to look at the camera or get as close to the camera as possible.</p> <p>The flash always fires twice, and the photograph is taken at the second firing.</p> <p>When the camera mode is [] and [], the flash will fire to suit the brightness of the subject.</p> <p>When the camera mode is [], [] and [], the flash will always fire.</p>
<p>[] Forced Flash</p>	<p>In this mode, the flash always fires. Use this mode for photographing under artificial light such as backlighting, fluorescent lighting, etc.</p>
<p>[] Flash Off</p>	<p>Use this mode when taking pictures using indoor lighting, for stages and indoor competitions, and when the subject is too far away for the flash to be effective.</p>



NOTE

- On the [] scene mode, the flash mode is fixed to [] Red-eye Reduction.
- On the [] scene mode, the flash mode is fixed to [] Suppressed Flash.
- On the [] scene mode, the flash mode is fixed to [] Forced Flash.
- On the [] focus mode, the flash mode is fixed to [] Suppressed Flash.
- The flash cannot be set in the [] mode and capture mode [Continuous] and [Auto Exp.].

Setting the Focus

Photographs can be taken with the distance to the subject set by auto focus, [] macro, [] infinity, [**3M**] fixed at 3 m, or [**1M**] fixed at 1 m.

The settings will be maintained even when the power is turned off or when Auto Power Off is activated. The focus settings will be

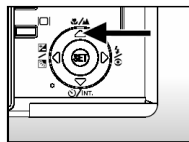

limited depending on the selected photography.

1. Set the mode dial to one of the photography modes.
2. Toggle the / button to select the desired focus mode.
 - Each press of the / button moves the icon one step through the sequence and displays it on the screen.
 - For the modes of [], [], [], [], [], [] and []:



- For the modes of [] and []:

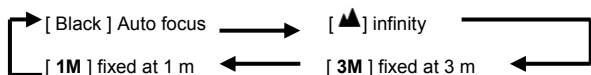

The table below will help you choose the appropriate focus mode:

Flash Mode	Description
[Black] Auto focus	Selects this when you want to leave the settings up to the camera so that you can take photographs without paying attention to settings. Approximately 80 cm (both Wide and Tele)
[] Macro	Selects this when you want to takes a close up photography. Wide (zoom off) : Approximately 9 cm to infinity Tele (at optical zoom 3x) : Approximately 30 cm to infinity
[] Infinity	Selects this when you want to take photographs of subjects at a distance of 5 m or more from the camera.
[3M] Fixed at 3 m	Selects this when you want to take photographs of subjects at a distance of about 3 m from the camera.
[1M] Fixed at 1 m	Selects this when you want to take photographs of subjects at a distance of about 1 m from the camera.

**NOTE**

- When [▲], [3M] or [1M] is set, the camera takes photographs with the focus fixed at those distances.

Self-timer/Photographing at Intervals

This setting allows photographs to be taken with the self-timer and allows interval photography.

1. Set the mode dial to one of the photography modes.
2. Toggle the [⏸/INT.] button to select the setting.
 - Each press of the [⏸/INT.] button moves the icon one step through the sequence and displays it on the screen.

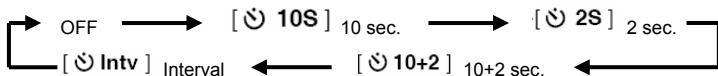
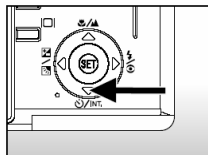



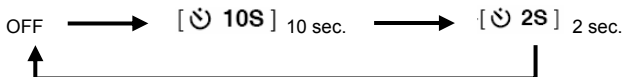

- For the [📷] mode and capture mode ([Continuous] and [Auto Exp.]



3. Compose the picture, press the shutter button down halfway, and then press it down fully.
 - The self-timer LED flashes and the photograph is taken after the preset time has elapsed.
 - The countdown is displayed on the LCD monitor.
 - To cancel the self-timer during operation, press the **SET** button.

The table below will help you choose the appropriate self-timer mode:

Self-timer mode	Description
[ 10S] 10 sec.	The picture is taken about 10 seconds after the shutter button is pressed.
[ 2S] 2 sec.	The picture is taken about 2 seconds after the shutter button is pressed.
[ 10+2] 10+2 sec.	One picture is taken about 10 seconds after the shutter button is pressed, then the camera prepares for another photograph (charging the flash). The other photograph is taken 2 seconds after this preparation is completed. This is convenient when taking group photographs in succession.
[ Intv] Interval	This allows photographs to be taken with settings of a fixed interval and number of photograph cycles. The photographic interval can be set to 1, 3, 10, or 60 minutes, and the number of photograph cycles can be set from 2 to 99. During the interval between one photograph and another, the viewfinder LED flashes red and the LCD monitor is automatically turned off. (standby mode)





NOTE





- The self-timer setting is automatically cancelled after a photograph is taken.
- Use of the [ 2S] self-timer setting is effective in preventing the blurring that can result when the shutter button is pressed.
- The number of photographs that can be taken will differ depending on the capacity of the memory, the image settings, and other factors.
- The interval photography is not available for TIFF setting.

Exposure Compensation/Backlight Correction

Photographs can be taken with the overall screen intentionally made brighter or darker. These settings are used when a suitable brightness (exposure) cannot otherwise be obtained in circumstance where the difference in brightness between the subject and the background (the

contrast) is large, or when the subject that you want to photograph is very small within the screen. Exposure can be set in 0.3 EV units.

1. Set the mode dial to one of [P], [Tv] or [Av] and press the [ / ] button.

- Each press of the [ / ] button displays the setting in the order of [Blank],  Backlight Correction, and  Exposure Compensation.

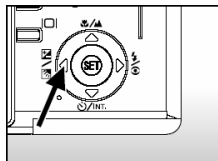

2. Set the exposure value with the search dial.

- Turn the search dial to the ▲ side to decrease the value.
- Turn the search dial to the ▼ side to increase the value.
- The setting range of the exposure compensation is as follows.

-2.0, -1.7, -1.3, -1.0, -0.7, -0.3, 0, +0.3, +0.7, +1.0,
+1.3, +1.7, +2.0

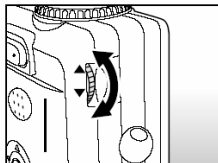

Effective Subjects and Set Values

■ Positive (+) Compensation

- * Printed matter comprising black text on whitish paper
- * Backlighting
- * Bright scenes or strong reflected light such as ski slopes
- * When the sky accounts for a large area on the screen



■ Negative (-) Compensation

- * People illuminated by a spotlight, in particular, against dark background
- * Printed matter comprising white text on blackish paper
- * Weak reflecting bodies such as evergreen trees or darkish leaves

■ Backlight correction (+1.3, fixed)

- * When the background is bright and the subject is dark.
- * When subjects (people) have a light source such as the sun to their backs.

**NOTE**

- The backlight correction setting can be set in the [**A**], [**P**], [**Tv**], [**Av**], [] and [] modes.

[**P**] Program (Automatic Exposure) Photography Mode

The camera automatically sets the shutter speed and the aperture to suit the brightness of the subject. This allows you to take photographs with ease just like when the [**A**] mode is selected.

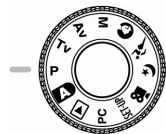

1. Set the mode dial to [**P**].
2. Compose the picture, press the shutter button down halfway, and then press it down fully.

**NOTE**

- Exposure compensation can be set.

[**Tv**] Shutter Speed Priority Photography Mode

In this mode, photographs are taken with the priority given to shutter speed. The aperture is automatically set according to the shutter speed. If you set a fast shutter speed, you can take photographs of moving subjects that look as if they are still. If you set a slow shutter speed, you can take photographs that give the impression that the subject is in motion.

1. Set the mode dial to [**Tv**] and press the  /  button.
2. Set the shutter speed with the search dial.
 - Turn the search dial to the ▲ side (toward faster shutter speeds)
 - Turn the search dial to the ▼ side (toward slower shutter speeds)
 - The setting range is as follows.
1/1500, 1/1250, 1/1000, 1/800, 1/650, 1/500, 1/400, 1/320, 1/250, 1/200, 1/160, 1/125, 1/100, 1/80, 1/64, 1/50, 1/40, 1/32, 1/25, 1/20, 1/16, 1/13, 1/10, 0.13s, 0.16s, 0.20s, 0.25s, 0.3s, 0.4s, 0.5s, 0.6s, 0.8s, 1s, 1.3s, 1.6s, 2s, 2.5s, 3.2s, 4s, 5s, 6.4s, 8s
 - The shutter speed and corresponding aperture value are displayed on the screen. If an appropriate combination cannot be set, the aperture value is displayed in red, but

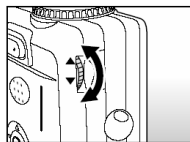
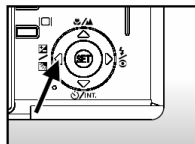
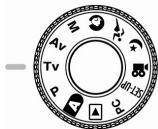

photographs can be taken.

3. Compose the picture, press the shutter button down halfway, and then press it down fully.



NOTE

- Setting the shutter speed slower than 0.5 second will result in long exposure photography and the [] will be displayed on the screen.
- In the flash photography mode, when [] and [] are set, the fastest shutter speed is 1/250 second.
- In the capture mode [Continuous] and [Auto Exp.], the shutter speed cannot be set slower than 0.5 second.

[Av] Aperture Priority Photography Mode

In this mode, photographs are taken with the priority given to aperture. The shutter speed is automatically set according to the aperture.

If you set a small aperture (higher F value), you can take portrait photographs with an out-of-focus background. Alternatively, if you set a large aperture (lower F value), both close objects and distant objects will be in focus, for example when taking landscape photographs.

1. Set the mode dial to [Av] and press the [] button.
2. Set the aperture value with the search dial.
 - Turn the search dial to the ▲ side to increase the value.
 - Turn the search dial to the ▼ side to decrease the value.
 - The setting range is as follows. F6.7/F5.6/F4.8/F4.0/F3.5/F2.8
 - The aperture and corresponding shutter speed are displayed on the screen. If an appropriate combination cannot be set, the shutter speed value is displayed in red, but photographs can be taken.
3. Compose the picture, press the shutter button down halfway, and then press it down fully.

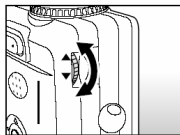
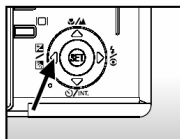
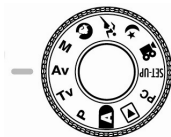



NOTE

- The aperture value is adjusted automatically depending on the position of the zoom lens.



[M] Manual Photography Mode

In this mode, photographs are taken by setting the aperture value and the shutter speed individually.

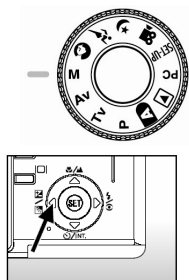

1. Set the mode dial to [M].
2. Select the shutter speed or the aperture with the  /  button.
3. Set the shutter speed or the aperture value with the search dial.
4. Compose the picture, press the shutter button down halfway, and then press it down fully.





NOTE



- In the flash photography mode, when [] and [] are set, the fastest shutter speed is 1/250 second.
- Setting the shutter speed slower than 0.5 second will result in long exposure photography and the [] will be displayed on the screen.



Setting the Scene Mode

This sets the scene setting such as [] portrait, [] sports or [] night scene and takes the photograph.

1. Set the mode dial to one of the scene modes.
 - When the camera mode is set to the [] or [], [] cannot be selected.
2. Compose the picture, press the shutter button down halfway, and then press it down fully.

The table below will help you choose the appropriate scene mode:

Scene Mode	Description
[] Portrait	Selects this when you want to take a photograph that makes the person stand out and blurs the background. The flash setting is fixed at [] which is effective in reducing the red-eye phenomenon.

 Sports	Selects this when you want to photograph fast-moving subjects. The flash mode cannot be set.
 Night scene	Selects this when you want to photograph people with an evening or night scene background. The flash is fixed at [].



NOTE

- The description of each scene serves as a general guide. Set the camera to suit your own preferences.

[] Movie Mode

This mode is for recording video clips. Voice can also be recorded.

1. Set the mode dial to [].
2. Compose the picture with the zoom button.
 - Optical zoom and digital zoom can be set while composing.
3. Fully pressed the shutter button.
 - The recording of the video clip will start.
 - Pressing the shutter button one more time will end the recording of the video clip, and record the image on the SD card.
 - The recording time depends on the storage size and the subject of the picture to be recorded.



NOTE

- On the [] mode, the LCD monitor cannot be turned off.
- When recording video clips, flash photography is not possible.
- While the image is being recorded into the SD card, do not open the battery/SD card cover, nor remove the battery or SD card. Doing so might damage the SD card or destroy the data of the SD card.

[▶] PLAYBACK MODE

Playing Back Still Images

You can play back the still images on an LCD monitor. Insert the SD card into the camera and turn on the power before starting.

- Set the mode dial to [▶].
 - The last image appears on the screen.
- Turn the search dial to move forward or reverse.
 - Turn to the ▲ side: go back to the previous frame.
 - Turn to the ▼ side: advance to the next frame.
 - The images can also be fed in reverse or fed forward by pressing the ▲ / ▼ buttons.

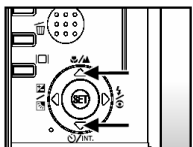
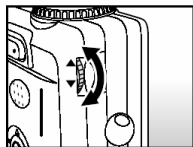
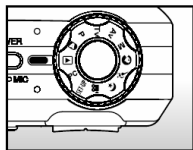

Image Display Information

You can switch the state of the information display by pressing the [i] button when playing back images. Each press of the

[i] button switches the information display state in the following order:



**NOTE**

- Pressing the ◀ / ▶ buttons during image playback will result in a 90 degree rotated display.
The ▶ button rotates the image clockwise and displays it, whereas the ◀ button rotates the image counterclockwise and displays it. A press of the button opposite to the direction in which the image was rotated will return the image to the normal display.
- A [📺] icon is displayed with the video data. Video clips cannot be rotated.
- A [🗣️] icon is displayed with images which have an audio memo recorded.
- Press the **SET** button to playback the voice memo data.
- In the zoom playback, the display is switched between normal and no display.
- The condition of the information display cannot be switched with video clips.

Playing Back Video Clips

You can play back video clips recorded on the camera. You can also play back voice.

1. Set the mode dial to [📺].
 - The last image appears on the screen.
2. Select the desired video clip with the search dial.
 - You can also select the desired video clip with the ▲ / ▼ buttons.
3. Press the **SET** button.
 - A press of the ▶ / ◀ buttons during playback allows fast forward play / fast reverse play.
 - To stop video playback:
Press the ▼ button.
This stops playback and returns to the start of the video clip.
 - To pause video playback
Press the ▲ button.
This pauses video playback.
To cancel pause, press the ▲ button again.

Button Operations

	During playback	During pause	During a Stop
▶ button	Fast forward play Each press of the ▶ button moves the operation one step in the sequence of 2 times fast forward play, 4 times fast forward play, and regular play.	2x-speed playback	/

◀ button	Reverse play Each press of the button moves the operation one step in the sequence of 2 times fast reverse play, 4 times reverse play, and regular forward play.	Reverse playback	
▲ button	Pause	Canceling pause	The previous image is displayed.
▼ button	Stop (The display returns to the 1st frame playback)		The next image is displayed.
SET button	Regular forward play	Canceling pause	Regular forward play



NOTE

- Video clips cannot be displayed rotated or enlarged.
- Turning the search dial during a pause, feeds the video forward or backward, respectively, one frame at a time. Turning the search dial to the ▼ side feeds the video forward; turning to the ▲ side feeds the video backward.

Playing Back Still Images/Video Clips on a TV

You can also playback your images on a TV screen. Before connecting to any devices, make sure to select NTSC / PAL system to match the video output system of the video equipment you are going to connect to the camera, then turn all connected devices off. It is also recommended to use the AC power adapter while transferring the recorded images and video files.

1. Set the mode dial to [▶].
2. Connect one end of the A/V cable to the A/V OUT terminal of the camera.
3. Connect the other end to the A/V input socket of the TV set.
4. Turn the TV and camera on.
5. Play back the still images / video clips.
 - The method of operation is the same as playing back still images and video clips on the camera.

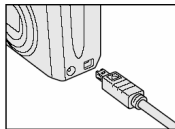

NOTE

- In the case of the PAL system, images are surrounded by a black frame.
- Refer to section in this manual titled "Video Output" in the **Setup Menu (Custom)** for further details.

Recording Voice Memos

A maximum of 30 seconds of audio can be recorded like a memo for photographed still images. The voice memo can be recorded only once.

- Set the mode dial to [▶].
 - The last image appears on the screen.
- Select the image with the search dial.
- Press the shutter button.
 - [VOICE RECORDING] is displayed on the screen and recording starts.
- To stop recording voice memo during recording, press the shutter button again.
 - [VOICE RECORD END] will be displayed and the recording will end.

A [📌] icon is displayed with images that have been recorded with a voice memo.

Playing back voice memo

A press of the **SET** button displays [VOICE PLAYBACK] and plays back the voice memo.



NOTE

- Voice memo is available in the still single image capture mode.



Thumbnail Display

This function allows you to view 9 thumbnail images on the LCD monitor at the same time, which can quickly search for the image that you want.

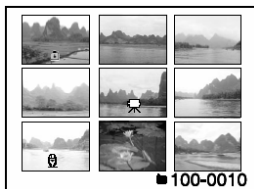
- Set the mode dial to [▶].
 - The last image appears on the screen.
- Press the [📌] button once.
 - The images are displayed in the thumbnail display.
 - Images that have been selected with the ▲ / ▼ / ◀ / ▶ buttons or the search dial will be indicated by a green frame.
 - When there are ten or more images, scroll the screen with the ▲ / ▼ buttons or the search dial.
- Press the ▲ / ▼ / ◀ / ▶ buttons to select the image to be displayed at regular size.
- Press the **SET** button.
 - The selected image is displayed at its regular size.















 **NOTE**

- A , ,  icon will be displayed in a thumbnail display.

Zoom Playback



Images that are being play back can be enlarged and displayed in 2 levels of 2 times and 4 times enlargement. This mode also allows you to enlarge your image on the selected portion of the image to check for small details.

1. Set the mode dial to .
2. Press the  /  buttons to select the image you want to enlarge.
 - You can also select the image you want to enlarge with the search dial or from the thumbnail display.
3. Adjust the zoom ratio with the  /  buttons.
 - Pressing the  button enlarges the image.
 - To return to normal magnification, press the  button.
 - The image is displayed enlarged, and a white frame and green frame are displayed on the LCD monitor.
 - The white frame indicates the entire image, while the green frame shows the location of the currently enlarged area.
4. Press the  /  /  /  buttons to select the area to enlarge.
5. To return to regular display, toggle the  button until the regular display appears on the screen.



Entire image Current position of enlargement

 **NOTE**

- Pressing the  button magnifies the image from 1x → 2x → 4x.
- Pressing the  button reduces the image from 4x → 2x → 1x.

Slideshow Display

The slideshow function enables you to playback your still images automatically in order one image at a time.

- Set the mode dial to [▶].
- Press the **MENU** button.
 - The playback menu is displayed.
- Select [Slide Show] with the ▲ / ▼ buttons, and press the **SET** button.
 - The slideshow starts.
- To stop the slide show during playback, press the **SET** button.
 - The image is displayed on screen when you press the **SET** button.

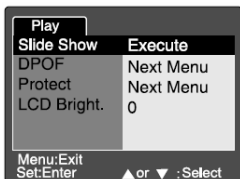

NOTE

- The Auto Power Off function does not operate during slide show.
- All images in the folder are automatically played back.



Protecting Images

Set the data to read-only to prevent images from being erased by mistake.

Protecting Images

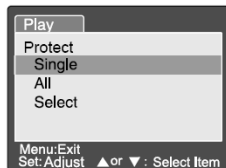





- Set the mode dial to [▶].
- Select the image that you want to protect with the search dial.
- Press the **MENU** button.
 - The playback menu is displayed.
- Select [Protect] with the ▲ / ▼ buttons, and press the **SET** button.
- Select [Single] or [All] with the ▲ / ▼ buttons, and press the **SET** button.
- Select [Set] with the ▲ / ▼ buttons, and press the **SET** button.
 - Protect is executed and the camera returns to the play mode.













- The protect icon [] is displayed with protected images. When [All] has been selected, [] is displayed with all the images.

Canceling the Protection

To cancel protection for only one image, display the image that you want to remove the image protection.



1. Select [Protect] with the  /  buttons from the playback menu, and press the **SET** button.
2. Select [Single] or [All] with the  /  buttons, and press the **SET** button.
3. Select [Cancel Protect] with the  /  buttons, and press the **SET** button.
 - The removal of image protection is executed and the camera returns to the play mode.

Protecting multiple images simultaneously

1. Select [Protect] with the  /  buttons from the playback menu, and press the **SET** button.
2. Select [Select] with the  /  buttons, and press the **SET** button.
 - The images are displayed in the thumbnail display.
3. Select the image you want to protect with the  /  /  /  buttons, and press the  button.
 - The protect icon [] is displayed with protected images. Selecting a protected image and pressing the  button again will cancel the protection. This procedure is repeated to select multiple images.
4. Press the **SET** button.
 - Protection and cancellation the protection are executed and the camera returns to the play mode.



NOTE

- Formatting the SD card undoes the protection, and erases all images.
- Even when multiple folders exist in the SD card, the images of all of the folders can be selected with the  /  buttons or the search dial.

DPOF Settings

DPOF is the abbreviation for Digital Print Order Format, which allows you to embed printing information on your memory card. You can select the images to be printed and how many prints to make with the DPOF menu in the camera and insert the memory card to the card compatible printer. When the printer starts printing, it will read the embedded information on the memory card and print the specified images.

- Set the mode dial to [P].
- Select the image that you want to set DPOF with the search dial.
- Press the **MENU** button.
 - The playback menu is displayed.
- Select [DPOF] with the ▲/▼ buttons, and press the **SET** button.
 - The DPOF setting screen is displayed.
- Select [Single] or [All] with the ▲/▼ buttons, and press the **SET** button.
 - Single: Sets DPOF for each individual image.
 - All: Sets DPOF for all images at once.
- Select [Print Num.] with the ▲/▼ buttons, and press the **SET** button.
 - This displays the number of prints setting screen.
- Set the number of prints with the ▲/▼ buttons, and press the **SET** button.
 - You can set up to 9 prints for each image.
- Select [Date] with the ▲/▼ buttons, and press the **SET** button.
 - The date and time setting screen appears.
- Select date to [ON] or [OFF] with the ▲/▼ buttons, and press the **SET** button.
 - ON**: The date of the photograph will also be printed.
 - OFF**: The date of the photograph will not be printed.
- Select [Print Enable] with the ▲/▼ buttons, and press the **SET** button.
- Select [Execute] with the ▲/▼ buttons, and press the **SET** button.
 - This creates a file containing the DPOF information, and when the operation is finished, the screen returns to the playback screen.

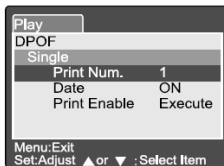
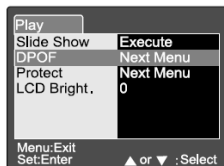

**NOTE**

- The date that is printed on the photo is the date set on the camera. To print the correct date on the photo, set the date on the camera before you photograph the image. Refer to section in this manual titled **"Setting the Date and Time"** for further details.
- Even when multiple folders exist in the SD card, the images of all of the folders can be selected with the ▲ / ▼ buttons or the search dial.

[🗑️] Erasing Images**Erasing at Photography Mode (Quick Delete Function)**

Quick delete function enables you to erase the image during photography. The quick delete menu provides you to directly erase the last image without further settings.

1. Set the mode dial to one of the photography modes.
2. Press the 🗑️ button.
 - The last image and quick delete menu appear on the screen.
3. Press the **SET** button to erase the image.
 - To not erase, select [Cancel], and press the **SET** button.

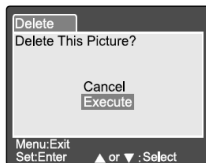
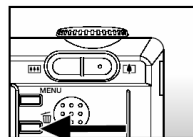
**Erasing at Playback Mode**

Erasing single image / Erasing all images

1. Set the mode dial to [📺].
 - The last image will be displayed on the screen.
2. Select the image you want to erase with the search dial.
3. Press the 🗑️ button.
 - The deletion menu will be displayed.
4. Select [Single] or [All] with the ▲ / ▼ buttons, and press the **SET** button.
 - **Single:** Erases the selected image or the last image.
 - **All:** Erases all of the images on the SD card except for the protected images.

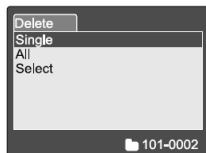

Select: Erases a number of selected images.

5. Select [Execute] with the ▲/▼ buttons, and press the **SET** button.
 - To not erase, select [Cancel], and press the **SET** button.





NOTE

- Even if you take photographs after erasing an image, the file number is assigned the next number of the very last one before the image was erased.

Erasing selected images.

This erases a number of selected images.

1. Set the mode dial to [P].
2. Press the  button.
 - The deletion menu will be displayed.
3. Select [Select] with the ▲/▼ buttons, and press the **SET** button.
 - The images are displayed in the thumbnail display.
4. Select the image you want to erase with the ▲/▼/◀/▶ buttons, and press the button.
 - The  icon will be displayed. One more press of the erase button will cancel the operation. Repeat this procedure and select all the images that you want to erase.
5. Press the **SET** button.

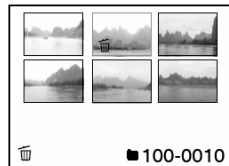
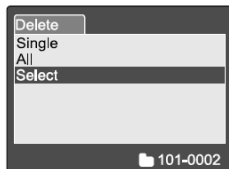

MENU OPTIONS

Photography Menu (Picture)

This menu is for the basic settings to be used when taking pictures in the photography mode. The setting is not canceled even if the camera is turned off or the Auto Power Off function is activated.

1. Set the mode dial to one of the photography modes.
2. Press the **MENU** button.

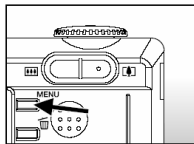

- [Picture] of the photography menu is displayed.
3. Select the desired [Picture] option item with the ▲/▼ buttons, and press the **SET** button to enter its respective menu.
 4. Select the desired setting with the ▲/▼ buttons, and press the **SET** button.
 5. To exit from the photography menu, press the **MENU** button.

Size

This sets the size of the image that will be photographed.

[Still picture]

2816 x 2112:	2816 x 2112 pixel (6M)
2272 x 1704:	2272x1704 pixel (4M)
1600 x 1200:	1600x 1200 pixel (2M)
640 x 480:	640 x 480 pixel (VGA)

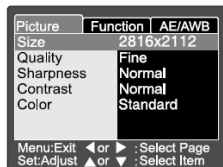

[Video clip]

320 x 240 : 320 x 240 pixel

Quality

This sets the quality (compression rate) at which the photograph is taken.

Fine:	Low compression rate
Standard:	Normal
Economy:	High compression rate
TIFF:	No compression rate (the highest image quality and the largest file sizes.)



NOTE

- Economy setting cannot be set in the [] mode.
- TIFF setting is selectable only when size setting is set to 2816x2112.

Sharpness

This sets the sharpness of the image that will be photographed.

Hard:	Hard touch
Normal:	Normal touch
Soft:	Soft touch



NOTE

- This setting cannot be set in the [] mode.

Contrast

This sets the difference between the bright and dark portions of the image that will be photographed.





- Hard:** Increases the contrast.
Normal: Set the contrast automatically.
Soft: Decreases the contrast.

Color

This sets the color of the image that will be photographed.

- Standard:** Standard color
Vivid: Bright color
Sepia: Sepia
Monochrome: Black-and-white

Photography Menu (Function)

1. Set the mode dial to one of the photography modes.
2. Press the **MENU** button, and select the [Function] menu with the  button.
 - [Function] of the photography menu is displayed.
3. Select the desired [Function] option item with the  /  buttons, and press the **SET** button to enter its respective menu.
4. Select the desired setting with the  /  buttons, and press the **SET** button.
5. To exit from the photography menu, press the **MENU** button.

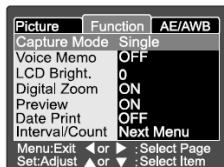

Capture Mode

This sets the recording method at the time of taking pictures.

() **Single:** Takes one photograph at a time.

() **Continuous:** Permits continuous photography of 5 pictures max, at the fastest interval of 0.62 seconds.

- (AEB) Auto Exp.: Effective when it is difficult to determine the exposure for continuous photography with exposure at the 3 levels of standard exposure (0), underexposure (-0.67) and overexposure (+0.67) compensation.



NOTE

- In continuous photography, press and hold the shutter button until 5 images have been captured. If the shutter button is released earlier, the continuous photography will end at that point.
- When the size setting is set to TIFF, the maximum recordable number is 3 shots.

Voice Memo

A voice memo can be recorded for 30 seconds immediately following still single image photography. This feature is also available during playback mode.

Refer to section in this manual titled "[**A**] Auto Photography Mode" for further details.

ON: Enable voice memo.

OFF: Disable voice memo.





NOTE

- When voice memo is set to on, the preview setting is also fixed to on.

LCD Bright.

Select a brightness level for the LCD monitor.

The LCD becomes brighter with the  button and darker with the  button. The adjustment range is from -5 to +5.

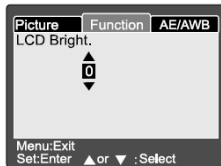

Digital Zoom

This sets whether or not to use digital zoom at the time of photography.

ON: Enable digital zoom.

OFF: Disable digital zoom.

Preview

This sets whether or not to display the photographed image on the screen immediately after the picture is taken.

ON: Displayed when images are being recorded on the SD card.

OFF: Does not display.



NOTE

- A photographed image is displayed on the LCD monitor for 2 seconds.
- When preview is set to off, the voice memo setting is also fixed to off.

Date Print

The date of recording can be printed directly on the still images. This function must be activated before the image is taken.

ON: Imprints the date on the still images when taking pictures.

OFF: Does not imprint the date on the still images when taking pictures.

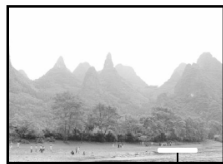

Date imprinted here.

Interval/Count

This automatically photographs at a fixed interval for the number of set cycles.

It is effective when the [ Intv] is set with the ▼ button.

1 Min.: Photographs at a 1-minute interval.

3 Min.: Photographs at a 3-minute interval.

10 Min.: Photographs at a 10-minute interval.

60 Min.: Photographs at a 60-minute interval.

Number of photographs: Can be set from 2 to 99 times.

Refer to section in this manual titled “**Selftimer/Photographing at Intervals**” for further details.

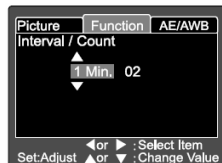

NOTE

- The number of photographs that can be taken will differ depending on the capacity of the memory, the image settings, and other factors.
- During the interval between one photograph and another, the viewfinder LED flashes red and the camera power is automatically turned off.

Photography Menu (AE/AWB)

1. Set the mode dial to one of the photography modes.
2. Press the **MENU** button, and select the [AE/AWB] menu with the  button.

- [AE/AWB] of the photography menu is displayed.
3. Select the desired [AE/AWB] option item with the ▲ / ▼ buttons, and press the **SET** button to enter its respective menu.
 4. Select the desired setting with the ▲ / ▼ buttons, and press the **SET** button.
 5. To exit from the photography menu, press the **MENU** button.

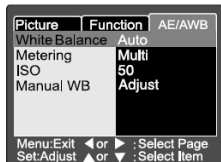

White Balance

This sets the white balance photographing under a variety of lighting conditions and permits photographs to be taken that approach the conditions that are seen by the human eye.

- Auto:** Automatic adjustment.
- Incandescent:** Photography under incandescent lighting.
- Fluorescent 1:** Photography under a daylight fluorescent tube with a bluish cast.
- Fluorescent 2:** Photography under a daylight white fluorescent tube with a reddish cast.
- Day Light:** Outdoor photography.
- Cloudy:** Photography under a cloudy sky.
- Manual:** Photography with a Manual WB.

Metering

This sets the metering method for calculating the exposure.

- Multi:** The entire area of the screen is measured, and the exposure is calculated.
- Spot:** A very small portion of the center of the screen is measured, and the exposure is calculated.

ISO

This sets the sensitivity for taking pictures. When the sensitivity is raised (and the ISO figure is increased), photography will become possible even in dark locations, but the more pixelated (grainer) the image will appear.

- 50:** Equivalent to ISO50.
- 100:** Equivalent to ISO100.
- 200:** High-sensitive photography equivalent to ISO200.
- Auto:** Automatic setting in the range of ISO 50 to 200 (Selection is permitted only when set to the [P] mode.)

Manual WB

This manually sets the white balance and stores it. Use of this is convenient when the white

balance does not offer a good match.

Before select [Execute] determine the subject (such as a white paper) that will be used to set the white balance.

Cancel: Disable manual white balance.

Execute: Enable manual white balance.

Playback Menu

In the [▶] mode, set which settings are to be used for playback. The setting is not canceled even if the camera is turned off or the Auto Power Off function is activated.

1. Set the mode dial to [▶].
2. Press the **MENU** button.
 - The playback menu is displayed.
3. Select the desired option item with the ▲ / ▼ buttons, and press the **SET** button to enter its respective menu.
4. Select the desired setting with the ▲ / ▼ buttons, and press the **SET** button.
5. To exit from the playback menu, press the **MENU** button.

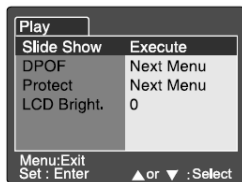

Slide Show

Automatically plays back still images in order one image at a time.

Refer to section in this manual titled "**Slideshow Display**" for further details.

DPOF

Set the number of prints and date display in DPOF format to images that you want to print. (This function is available for still images only.) You can print images easily just by inserting the SD card to a DPOF-compatible printer or a print shop.

Refer to section in this manual titled "**DPOF Settings**" for further details.

Protect

Set the data to read-only to prevent images from being erased by mistake.

Refer to section in this manual titled "**Protecting Images**" for further details.

LCD Bright.

Adjust the brightness of the LCD monitor. This function does not adjust the brightness of recorded images.

Refer to section in this manual titled “**LCD Bright.**” in **Photography Menu (Function)** for further details.

Setup Menu (Basic)

Set your camera's operating environment. The settings will be saved after the power has been turned off or Auto Power Off is activated.

- Set the mode dial to [SET-UP].
 - [Basic] of the set-up menu is displayed.
- Select the desired [Basic] option item with the ▲ / ▼ buttons, and press the **SET** button to enter its respective menu.
- Select the desired setting with the ▲ / ▼ buttons, and press the **SET** button.
- To exit from the set-up menu, change the mode dial setting.

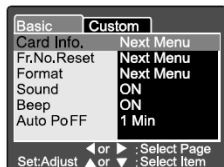

Card Info.

This allows a check of the free capacity of the SD card as well as other information.

Fr. No. Reset

This creates a new folder. The photographed images are recorded to the newly created folder from number 0001.

Cancel: Does not reset the file number.

Execute: Resets the file number and creates a new folder.

Format

This function erases all images and reformats the SD card loaded in your camera. Protected images are also erased. SD card cannot be formatted if it is write protected. Refer to section in this manual titled “**Formatting the SD Card**” for further details.

Sound

This sets whether or not to mute the playback sound of the recorded voice memo and voice recorded with the video clip.

ON: Does not mute the playback sound of the voice memo and voice recorded with the video

clip.

OFF: Mute the playback sound of the voice memo and voice recorded with the video clip.

Beep

This sets the camera sound each time you press the camera button if this function is enabled.

ON: Sounds the beep tone.

OFF: Does not sound the beep tone.

Auto PoFF

If no operation is performed for a specific period of time, the power to the camera is automatically turned off. This feature is useful to reduce battery wear.

1 Min.: When the camera has not been operated, it turns the power off after 1 minute.

2 Min.: When the camera has not been operated, it turns the power off after 2 minutes.

3 Min.: When the camera has not been operated, it turns the power off after 3 minutes.



NOTE

- This function does not operate during a slideshow or in the [PC] mode and during PC connection.

Setup Menu (Custom)

1. Set the mode dial to [**SET-UP**], and select the [Custom]

menu with the **▶** button.

- [Custom] of the set-up menu is displayed.

2. Select the desired [Custom] option item with the **▲ / ▼** buttons, and press the **SET** button to enter its respective menu.

3. Select the desired setting with the **▲ / ▼** buttons, and press the **SET** button.

4. To exit from the set-up menu, change the mode dial setting.

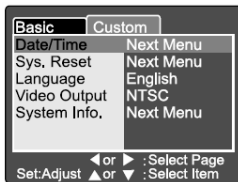

Date/Time

This sets the date and the time.

Refer to section in this manual titled "**Setting the Date and Time**" for further details.

Sys. Reset

This returns all basic settings to the camera's default settings. The time setting will not be reset.

Cancel: Does not return to the default settings.

Execute: Returns to the default settings.

Language

This sets the language that is displayed on the LCD monitor.

Refer to section in this manual titled "**Choosing the Language**" for further details.

Video Output

This sets video output system of the video equipment that you are going to connect to the camera.

NTSC: NTSC system.

PAL: PAL system.

System Info.

This displays the firmware version of the camera.

TRANSFERRING RECORDED IMAGES TO YOUR COMPUTER

You can share recorded images/video clips with your family or friends via e-mail or post them on the Web. Before doing this, you need to connect the camera to your computer by using the USB cable and then transfer the images/video clips.

To transfer images/video clips from the camera to your computer, follow the steps below:

Step 1: Install the USB driver (only for Windows 98)

Step 2: Connecting the camera to your computer

Step 3: Downloading images/video clips

	System requirements (Windows)	System requirements (Macintosh)
CPU	Pentium 166 MHz processor or higher	PowerPC G3/G4
OS	Windows	OS 8.6 or later

	98/98SE/Me/2000/XP	
Memory	64MB RAM	64MB RAM
Free Space on Hard Disk	128MB hard disk space	128MB hard disk space
Required Devices	A CD-ROM drive, An available USB port	A CD-ROM drive, An available USB port
Color Monitor	Color monitor (800x600, 24-bit or higher recommended)	Color monitor (800x600, 24-bit or higher recommended)

Step 1: Installing the USB driver on Windows computers

The USB driver on the supplied CD-ROM is exclusively for Windows 98. Installing the USB driver on computers running Windows 2000/ME/XP is not necessary.

1. Insert the CD-ROM packaged with the camera into the CD-ROM drive. The welcome screen appears.
2. Click "Install USB Driver". Follow the onscreen instructions to complete the installation.
3. After the USB driver installation is complete, restart your computer.

Installing the USB driver on Macintosh computers

Mac OS 8.6 users must install a USB driver. For Mac OS 9.0 or higher, the computer will automatically recognize the camera and load its own USB drivers.

1. Insert the CD-ROM packaged with the camera into the CD-ROM drive.
2. Select and double-click "Digital Camera Driver Installer".
3. Select "Install Location" and click "Install".
4. Follow the on-screen instructions to complete the installation and restart your computer.

Step 2: Connecting the camera to your computer

1. Set the mode dial to **PC** mode.
2. Connect one end of the USB cable to an available USB port on your computer.
3. Connect the other end of the USB cable to the USB connector on the camera.
4. From the Windows desktop, double click on "My Computer".

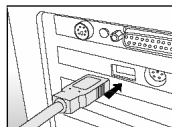

5. Look for a new “Removable disk” icon. This “Removable disk” is actually the memory card in your camera. Typically, the camera will be assigned drive letter “e” or higher.
6. Double click on the removable disk and locate the DCIM folder.
7. Double click on the DCIM folder to open it to find more folders.
 - Your recorded images and video clips will be inside these folders.
 - Copy & Paste or Drag-N-Drop image and video files to a folder on your computer.

Mac users: Double-click the “untitled” or “unlabeled” disk drive icon on our desktop. iPhoto may automatically launch.

Step 3: Downloading images/video clips

When the camera is turned on and connected to your computer, it is considered as a disk drive, just like a floppy disk or CD. You can download (transfer) images/video clips by copying them from the “removable disk” (“untitled” disk on a Macintosh) to your computer hard drive or to another kind of disk.

For computers running Windows

Open the “removable disk” by double-clicking on it. Double-click on the folder that contains your recorded images/video clips. Select the images/video clips that you prefer and choose “Copy” from the “Edit” menu. After that, open the destination location and choose “Paste” from the “Edit” menu.

For computers running Mac OS

Open the “untitled” disk window and the hard disk or the destination location. Drag and drop from the camera disk to the desired destination.



NOTE

- Memory card users may prefer to use a memory card reader (highly recommended).
- Video playback application is not included with the package. Make sure that video playback application has been installed in your computer.

Installing Presto! Mr. Photo

Presto! Mr. Photo is an ideal program for creating, sharing, and managing digital images and videos. In this new edition, users can add sound to their files for useful real-life effects. The straightforward, powerful photo enhancement functions can make your pictures come alive. You

can also adjust the photo quality and convert the file format for other applications. Mr. Photo also provides fun photo templates, motion shows, slideshows, e-mail, html, and links to other applications. It makes personalized creations easy for everyone.

To install Presto! Mr. Photo:

1. Insert the CD-ROM that came with the camera into your CD-ROM drive.
The welcome screen appears.
2. Click "Install MR. PHOTO".
Follow on-screen instructions to complete the installation.

**NOTE**

- For help on using Mr. Photo usage, refer to the Mr. Photo on-line help for more information.
- For Windows 2000/XP users, be sure to install and use the Mr. Photo in "Administrator" mode.
- Mr. Photo is not supported on the Mac.

Installing Presto! Image Folio

Image Folio is a comprehensive multimedia image-processing program. It enables you to process photographs, graphics, and drawings captured from scanners, VCRs, a laser discs, digital cameras, video capture boxes and any other location that the computer can capture images from.

You can create new images by using the Image Folio's powerful tools. This sophisticated set of image-editing tools enables you to quickly create new images or enhance pre-existing ones. With this program, your imagination is your only limit!

To install Presto! Image Folio:

1. Insert the CD-ROM that came with the camera into your CD-ROM drive.
The welcome screen appears.
2. Click "Install IMAGE FOLIO".
Follow on-screen instructions to complete the installation.

**NOTE**

- For help on using Image Folio usage, refer to the Image Folio on-line help for more information.
- For Windows 2000/XP users, be sure to install and use the Image Folio in "Administrator" mode.
- Image Folio is not supported on the Mac.

CONNECTING THE CAMERA TO OTHER DEVICES

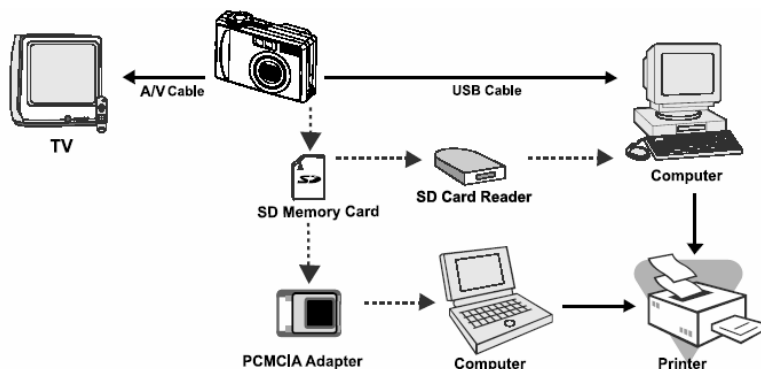

CAMERA SPECIFICATIONS

Item	Description
Image sensor	1/1.8" CCD sensor Total number of pixels: 6.3 mega pixels Number of effective pixels: 5.95 mega pixels
Image resolution	<Still picture> 2816x2112, 2272x1704, 1600x1200, 640x480 < Video clip> 320x240
LCD monitor	2.0" low temperature poly silicon LCD
Viewfinder	Real image optical zoom viewfinder
Image quality	Fine/Standard/Economy/TIFF (selectable atv2816x2112 only)
Recording medium	External memory: Bundled 32MB SD card (up to 512MB)
Compression format	JPEG compliant
Image file format	DCF 1.1, EXIF 2.2, AVI, TIFF
Lens	f=7.2 mm - 21.6 mm (equivalent to 35 mm - 105 mm on a 35 mm camera)

	F=2.8 - 4.7
Focus range	Approx. 80 cm to infinity (both Wide and Tele) Approx. 9 cm to infinity (Macro Wide) Approx. 30 cm to infinity (Macro Tele)
Auto-Focus	TTL method AF
Shutter speed	Long exposure: 8sec - 0.6 sec. Normal exposure: 1/2 sec.-1/1500 sec.
Digital zoom	4.4x (Capture mode) 2x and 4x (Playback mode)
Metering system	Multi metering, Spot metering
Exposure	Program AE/Shutter speed priority/Aperture priority/ Manual/Portrait /Sports / Night scene
Exposure compensation	-2EV - +2EV (in 0.3EV increments)
White balance	Auto / Incandescent / Fluorescent 1 / Fluorescent 2 / Daylight / Cloudy / Manual
Flash	Auto/ Red-eye reduction / Suppressed Flash / Forced flash
Flash effective range	0.6 m -3.0 m (Wide / ISO=200)
ISO sensitivity	Equivalent to ISO 50/100/200/Auto (ISO 50-ISO 200)
Self-timer	10 sec./2 sec. / 10+2 sec. /Interval (1, 3, 10, 60 min)
Video output	NTSC/PAL
Interface	DC IN 5V terminal A/V OUT terminal USB 1.1
Power supply	Lithium-ion battery (included) AC power adapter 5V
Dimension (WxDxH)	Approx. 94 x 63 x 35mm (without protruding parts)
Weight	Approx. 180g (without the battery & SD card)

* Design and specifications are subject to change without notice.