

USER MANUAL

PRESET VACUUM REGULATORS

CONTINUOUS &
CONTINUOUS INTERMITTENT

MODEL SERIES: PS3000

PS3100

PS3300

Patent Pending



PS3300 (Shown)



PS3100 (Shown)

SAVE THESE INSTRUCTIONS

CAUTION

Federal (USA) law restricts this device to sale by or on the order of a physician.

PRECISION MEDICAL

300 Held Drive
Northampton, PA 18067 USA
ISO 13485 Certified

Tel: (+001) 610-262-6090
Fax: (+001) 610-262-6080
www.precisionmedical.com

CONTENTS

RECEIVING / INSPECTION.....	2
INTENDED USE	2
READ ALL INSTRUCTIONS BEFORE USING	2
EXPLANATION OF ABBREVIATIONS	2
SAFETY INFORMATION - WARNINGS AND CAUTIONS	2
SPECIFICATIONS	3
OPERATING INSTRUCTIONS.....	4
PARTS DESCRIPTION	5
REPAIR KITS	6
DISASSEMBLY INSTRUCTIONS for PS3000 & PS3100 Series ...	7
DISASSEMBLY INSTRUCTIONS for PS3300 Series.....	7
ASSEMBLY INSTRUCTIONS	7
VACUUM REGULATOR CLEANING ILLUSTRATION	8
CLEANING / DECONTAMINATION.....	9
MAINTENANCE.....	9
RETURNS.....	9
DISPOSAL INSTRUCTIONS	10
TROUBLESHOOTING.....	10
LIMITED WARRANTY	11

RECEIVING / INSPECTION

Remove the Precision Medical, Inc. *Preset Vacuum Regulator* from the packaging and inspect for damage. If there is any damage, DO NOT USE and contact your Provider.

INTENDED USE

The *Preset Vacuum Regulator* is intended to regulate and display the amount of vacuum from a central vacuum system used in various medical suctioning procedures.

READ ALL INSTRUCTIONS BEFORE USING

This manual instructs a Professional how to install and operate the *Preset Vacuum Regulator*. This is provided for your safety and to prevent damage to the *Preset Vacuum Regulator*. If you do not understand how to use the *Preset Vacuum Regulator*, please contact your Provider.

EXPLANATION OF ABBREVIATIONS

l/min	Liters Per Minute
mmHg	Millimeters of Mercury
inHg	Inches of Mercury (1 inHg = 25.4 mmHg)

SAFETY INFORMATION - WARNINGS AND CAUTIONS

WARNING

Indicates a potentially hazardous situation which, if not avoided, could result in death or serious injury.

CAUTION

Indicates a potentially hazardous situation which, if not avoided, may result in minor or moderate injury.

CAUTION

Used without the safety alert symbol indicates a potentially hazardous situation which, if not avoided, may result in property damage.



CONSULT ACCOMPANYING DOCUMENTS

WARNING

- **DO NOT** use the *Preset Vacuum Regulator* for anything other than its Intended Use. Personal injury and/or damage to Regulator may result from misuse.
- Only personnel instructed and trained in its use should operate the *Preset Vacuum Regulator*.

SPECIFICATIONS

CALIBRATED RANGE

PS3000: 0 - 200 mmHg

PS3100: 0 - 200 mmHg

PS3300: 0 - 200 mmHg

PS3000HV: 0 - 300 mmHg

PS3100HV: 0 - 300 mmHg

PS3300HV: 0 - 300 mmHg

GAUGE ACCURACY

Analog Gauge ± 5% of MAX calibrated range

Dual Analog/Digital Gauge

Digital Display ± 1% of Full Scale

Analog Gauge ± 5% of MAX calibrated range within ref. Indicator

INLET/OUTLET CONNECTIONS 1/8 NPT Female

MODES OF OPERATION

PS3000 Series	OFF - No Vacuum REG. - (Regulated) Provides an adjustable, continuous vacuum level
PS3100 Series	OFF - No Vacuum REG. - (Regulated) Provides an adjustable, continuous vacuum level LINE - Provides maximum, continuous vacuum from the vacuum source
PS3300 Series	OFF - No Vacuum REG. - (Regulated) Provides an adjustable, continuous vacuum level INT. - (Intermittent) Provides an adjustable vacuum level that cycles between ON and OFF

FLOW RATES

PS3000, PS3100 & PS3300	REG MODE @ 200 mmHg	48 l/min
	LINE MODE	55 l/min
	INT. MODE (PS3300 Only)	10 l/min
PS3000HV, PS3100HV & PS3300HV	REG MODE @ 300 mmHg	50 l/min
	LINE MODE	55 l/min
	INT. MODE (PS3300HV Only)	10 l/min

FLOW RATES ARE OBTAINED WITH A VACUUM SOURCE OF 21" Hg

INTERMITTENT CYCLE TIME: Factory set at sixteen (16) seconds ON and eight (8) seconds OFF (*Reference only*)

Operating Environmental Limits: 0°F to 122°F (-18°C to 50°C)

Recommended Environmental Operating Limits: 55°F to 85°F (13°C to 29°C)

Storage Environmental Limits

Temperature Range: -4°F to 140°F (-20°C to 60°C)

Humidity: Max 95% Noncondensing

Battery: 3 Volt Lithium, 1/2 AA (*Digital Vacuum Gauge Models ONLY*)

Specifications are subject to change without prior notice.

OPERATING INSTRUCTIONS

CAUTION

Inspect the *Preset Vacuum Regulator* for visual damage before use, DO NOT USE if damaged.

- NOTE:**
- Overflow protection should be used with the Vacuum Regulator. (i.e. Filter, Vac Trap, Canister equipped with float shutoff).
 - The Digital / Analog Dual Gauges operate independently; if the digital gauge fails, the analog gauge will still function and vice versa.

1. Turn the Selector Knob to the "OFF" position.
2. Connect the *Preset Vacuum Regulator* to a vacuum source.
 - A. **REG. MODE (Regulated Mode) ALL MODELS**
 - a. Turn the gray Preset Knob to desired vacuum range.
 - b. Block the bottom port of the Vacuum Regulator with your finger and turn the white Selector Knob to the "REG." position.
 - c. The preset vacuum range should correspond with the gauge readings along with the increase and decrease in suction felt with the finger on blocked off bottom port.
 - d. Adjust vacuum as required.
 - To *INCREASE* vacuum - Turn gray Knob *CLOCKWISE*
 - To *DECREASE* vacuum - Turn gray Knob *COUNTERCLOCKWISE*
 - B. **LINE MODE (Full, unregulated vacuum) PS3100 Series ONLY**
 - a. Block off bottom port of the Vacuum Regulator with your finger and turn the Selector Knob to the "LINE" position. The gauge will indicate Max. vacuum and suction should be felt with finger on blocked off bottom port. In this mode the vacuum level cannot be set and will be full unregulated vacuum.
 - C. **INT. MODE (Vacuum cycles ON and OFF) PS3300 Series ONLY**
 - a. Turn the gray Preset Knob to desired vacuum range.
 - b. Block the bottom port of the Vacuum Regulator with your finger and turn the Selector Knob to the "REG." position.
 - c. The preset vacuum range should correspond with the gauge readings along with the suction felt with the finger on blocked off bottom port.
 - d. Adjust vacuum as required.
 - To *INCREASE* vacuum - Turn gray Knob *CLOCKWISE*
 - To *DECREASE* vacuum - Turn gray Knob *COUNTERCLOCKWISE*
 - e. Turn the Selector Knob to the "INT." position.
 - f. The intermittent cycle starts in the "OFF" phase. There will be approximately an 8 second delay before the device cycles to the "ON" phase for approximately 16 seconds. During the "ON" phase the gauge vacuum level should correspond with the preset vacuum level.
3. Turn the Selector Knob to the "OFF" position to turn the Vacuum off.

⚠ WARNING

- When turning the *Preset Vacuum Regulator* to "REG." from "LINE" or "OFF", the vacuum level will return to its previously regulated setting. Vacuum may be set at improper level for procedure.
- ***PS3300 Series ONLY:*** When turning the *Preset Vacuum Regulator* to "REG." or "INT." from any position, the vacuum level will return to its previously regulated setting. Vacuum levels will remain the same when switching from one mode to the other.
- ALWAYS confirm vacuum setting prior to performing procedure.
- The vacuum CANNOT be regulated when the Selector Knob is set to the "LINE" position.
- **Full Line Vacuum is present between settings.**
- The desired vacuum mode ("REG", "LINE", "INT.") and vacuum level should always be set and confirmed before interface with patient to perform suctioning procedure.

⚠ CAUTION

DO NOT operate the *Preset Vacuum Regulator* when the collection canister is "full". This may cause loss of vacuum and damage to the *Preset Vacuum Regulator*. This will **void the warranty**.

PARTS DESCRIPTION

⚠ CAUTION

Missing or illegible labels must be replaced, contact Precision Medical, Inc.

PS3000 & PS3100 SERIES

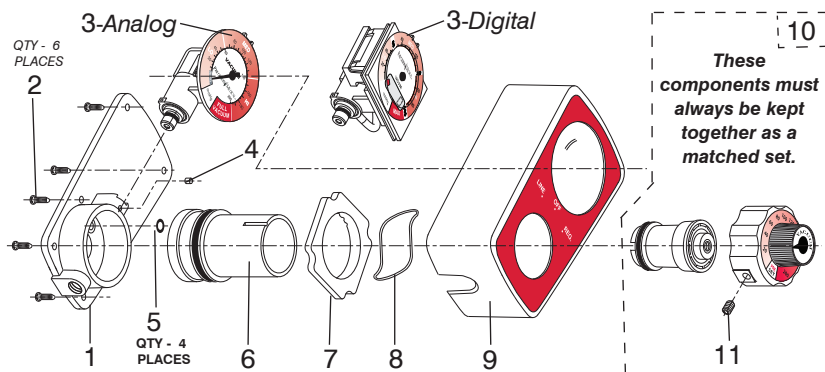

PARTS LIST

No.	Description	PS3000	PS3100
1	Housing Assembly	1561	
2	Screw	503956	
3	Analog Gauge (0-200 mmHg)	503694	
	Analog Gauge (HV) (0-300 mmHg)	504309	
	Dual Analog /Digital Gauge (0-200 mmHg)	505244	
	Dual Analog /Digital Gauge (HV) (0-300 mmHg)	505392	
4	Snubber	1396	
5	O-ring	1016	
6	Selector Assembly	1563	1564
7	Selector Ring	502685	
8	Wave Spring Washer	1614	
9	Case Assembly	1565	1566
10	Regulator Module/Control Knob Assembly	507480 (0 - 200 mmHg)	
		*507481 (0 - 300 mmHg)	
11	Set Screw	1391	
--	Battery for Dual Analog/Digital Gauge	8066	

* HV Models ONLY (PS3000HV, PS3100HV & PS3300HV)

PS3300 SERIES

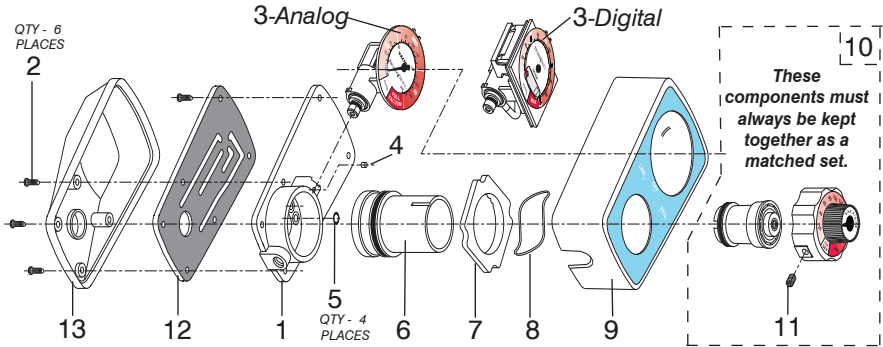

PARTS LIST

No.	Description	PS3300
1	Housing Assembly	502102
2	Screw	503956
3	Analog Gauge (0-200 mmHg) Analog Gauge (HV) (0-300 mmHg) Dual Analog /Digital Gauge (0-200 mmHg) Dual Analog /Digital Gauge (HV) (0-300 mmHg)	503694 504309 505244 505392
4	Snubber	1396
5	O-ring	502231
6	Selector Assembly	1805
7	Index Ring	502685
8	Wave Spring Washer	1614
9	Case Assembly	1827
10	Regulator Module/ Control Knob Assembly	507480 (0 - 200 mmHg) *507481 (0 - 300 mmHg)
11	Set Screw	1391
12	Timing Module	502103
13	Rear Case	1831
--	Battery for Dual Analog/Digital Gauge	8066

* HV Models ONLY (PS3300HV)

REPAIR KITS

	Analog Part#	Digital Part#
PS3000 / PS3000D Vac Reg	RKPS6000	RKPS6000D
PS3000HV / PS3000DHV Vac Reg	RKPS6000HV	RKPS6000DHV
PS3100 / PS3100D Vac Reg	RKPS6100	RKPS6100D
PS3100HV / PS3100DHV Vac Reg	RKPS6100HV	RKPS6100DHV
PS3300/PS3300D Vac Reg	RKPS6300	RKPS6300D
PS3300HV/PS3300DHV Vac Reg	RKPS6300HV	RK6300DHV

DISASSEMBLY INSTRUCTIONS for PS3000 & PS3100 Series

(Reference “PARTS DESCRIPTION”)

1. Loosen the Set Screw (Item# 11) in Selector Knob.
2. Pull the Regulator Module/Control Knob Assembly (Item # 12) away from case. (The Regulator Module (Item # 10) is threaded onto the Control Knob Assembly.
Note: These components must always be kept together as a matched set.)
3. Remove the screws (Item# 2) from the back of the Regulator.
4. Separate the Case Assembly (Item# 9) by pulling it away from the Housing Assembly (Item# 1).
5. Remove the Selector Assembly (Item# 6) by pulling it away from the Housing Assembly (Item# 1).
6. Remove Gauge by pulling vertically out of socket (Item# 3).

DISASSEMBLY INSTRUCTIONS for PS3300 Series

(Reference “PARTS DESCRIPTION”)

1. Loosen the Set Screw (Item # 11) in Selector Knob.
2. Pull the Regulator Module/Control Knob Assembly (Item # 12) away from case. (The Regulator Module (Item # 10) is threaded onto the Control Knob Assembly.
Note: These components must always be kept together as a matched set.)
3. Remove the screws (Item # 2) from the back of the product.
4. Remove the Rear Case (Item # 14) by pulling away from product.
5. Remove screws (Item# 2) from the top of the Timing Module.
6. Remove the Timing Module (Item# 13) by pulling away from the Housing Assembly (Item# 1).
7. Separate the Case Assembly (Item# 9) by pulling it away from the Housing Assembly (Item# 1).
8. Remove the Selector Assembly (Item# 6) by pulling it away from the Housing Assembly (Item# 1).
9. Remove Gauge by pulling vertically out of socket (Item# 3).

ASSEMBLY INSTRUCTIONS

1. To assemble, perform the “DISASSEMBLY INSTRUCTIONS” in reverse order.
Note: • Ensure the tab on the Regulator Module is inserted into the internal slot on the Selector Module at the 9 o’clock position.
• Ensure the tab on the Control Knob Assembly at the 12 o’clock position is aligned with the outer circumference slot on the Selector Module at the 12 o’clock position.
2. Lubricate all O-rings and cavities with Vacuum grease (part# 1775) supplied in the *Preset Vacuum Regulator Repair Kit*.
3. Repeat steps 1 through 3 of “OPERATING INSTRUCTIONS”.
4. Prior to returning *Preset Vacuum Regulator* to service verify preset vacuum level with gauge reading.

PRESET VACUUM REGULATOR CLEANING ILLUSTRATION

(Cleaning/Decontamination Instructions on **page 9**)

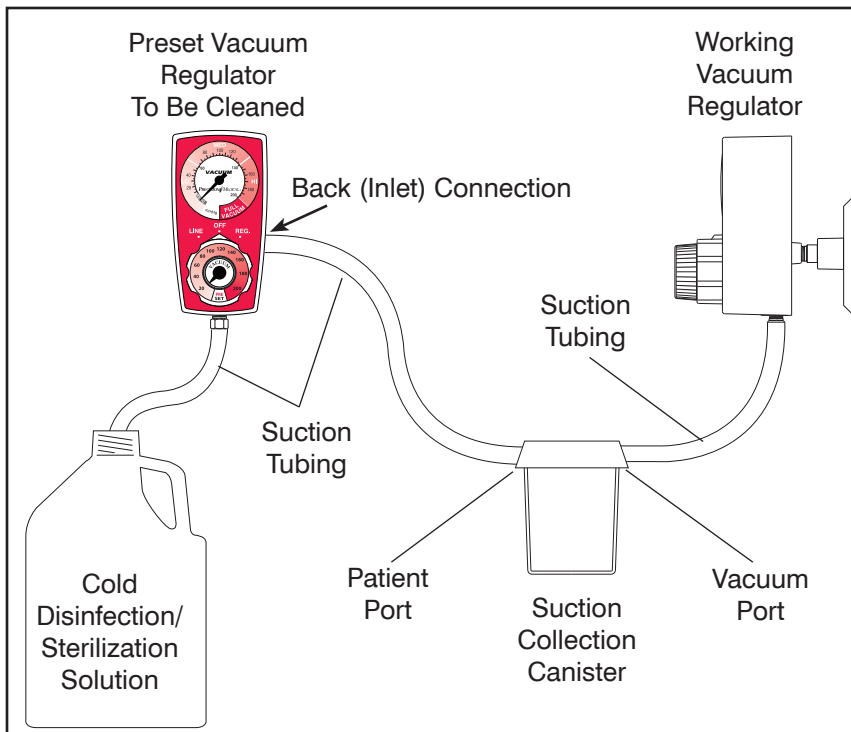

CAUTION

- **DO NOT** autoclave or immerse in liquid. This will cause damage to the *Preset Vacuum Regulator* and will void the warranty.
- If *Preset Vacuum Regulator* becomes internally contaminated, warranty is voided, **DO NOT** send back to Precision Medical, Inc. for repair. Follow the contaminated equipment protocol at your facility.
- Ensure all connections are tight and leak free.
- The *Preset Vacuum Regulator* contains magnetic, ferrous material that may affect the results of an MRI.

Tell us how we are doing!
Visit us at www.precisionmedical.com

CLEANING / DECONTAMINATION (As needed)

1. Attach a working Vacuum Regulator with a continuous regulated mode to a minimum vacuum source of 15 inHg.
2. Mix cold disinfection/sterilization solution according to its manufacturer's directions.
3. Connect tubing as shown in Cleaning Illustration on previous page.
4. Turn the working Vacuum Regulator on to a continuous regulated mode.
5. Adjust the vacuum to a minimum of 120 mmHg.
6. Set the "Preset" Vacuum Regulator to be cleaned to the "REG." mode, and set at 100 mmHg.
7. Allow cold disinfection/sterilization solution to pass through *Preset Vacuum Regulator* and collect in Suction Canister. Procedure should continue for time recommended by the manufacturer of the cold disinfection/sterilization solution for the desired level of disinfection or sterilization.
8. Turn the *Preset Vacuum Regulator* to be cleaned to the "LINE" mode (if applicable).
9. Allow remaining cold disinfection/sterilization solution to pass through and collect in Suction Canister.
10. Set working Vacuum Regulator to its maximum vacuum setting.
11. Thoroughly dry the internal components by drawing maximum vacuum through the cleaned Regulator for at least 30 seconds in both "REG." and "LINE" modes (if applicable).

NOTE: If it is not possible to pass cold disinfection/sterilization solution through the Regulator, then the passageways are totally blocked and **DISASSEMBLY** of the Regulator is required. Ensure to follow the Biohazard protocol at your facility.

MAINTENANCE

Before each use, visually inspect *Preset Vacuum Regulator* for any sign of damage. **DO NOT USE** if damaged.

RETURNS

Returned products require a Returned Goods Authorization (RGA) number, contact Precision Medical, Inc. All returns must be packaged in sealed containers to prevent damage. Precision Medical, Inc. will not be responsible for goods damaged in transit. Refer to Precision Medical, Inc. Return Policy available on the Internet, www.precisionmedical.com.

Note: Federal Law prohibits shipping of BioHazard materials Via U.S. mail.

Manuals available on our Website; www.precisionmedical.com

DISPOSAL INSTRUCTIONS

Dispose of the *Preset Vacuum Regulator* in accordance with local regulations.

Please Recycle



⚠WARNING

Biohazardous devices should be disposed of properly.

TROUBLESHOOTING

If the *Preset Vacuum Regulator* fails to function, consult the Troubleshooting Table below. If problem cannot be solved, consult your Provider.

Problem	Probable Cause	Remedy
No vacuum at bottom port (gauge at zero)	<ol style="list-style-type: none">1. Regulator turned "OFF"2. Loose connection3. No vacuum to Regulator4. Clogged vacuum Port	<ol style="list-style-type: none">1. a. Turn white Selector Knob to "REG." mode b. Adjust gray Preset Knob2. Tighten connection3. Connect to a known working vacuum source4. Disassemble and clean
No vacuum at bottom port (gauge showing vacuum)	Clogged Regulator	Disassemble and clean
Vacuum at bottom port (No reading on gauge when port is blocked)	Defective Gauge	Replace Gauge
Gauge will not return to zero	<ol style="list-style-type: none">1. Clogged Snubber2. Damaged Regulator Module3. Defective Gauge	<ol style="list-style-type: none">1. Replace Snubber2. Replace Regulator Module3. Replace Gauge
Vacuum Regulation erratic	<ol style="list-style-type: none">1. Dirty Regulator Module2. Defective Regulator Module	<ol style="list-style-type: none">1. Disassemble, clean and lubricate O-ring2. Replace Module
Stiff movement of white Selector Knob	Dirty Selector Module cavity or O-rings	Disassemble, clean casting cavity and lubricate cavity and O-rings
No digital display	Dead battery	Replace battery
<u>PS3300 Series ONLY:</u> No Intermittent (INT.) cycle	<ol style="list-style-type: none">1. Improper mode selected2. Defective Timing Module	<ol style="list-style-type: none">1. Turn Selector Knob to "INT." mode2. Replace Timing Module

LIMITED WARRANTY AND LIMITATION OF LIABILITY

Precision Medical, Inc. warrants that the Medical *Preset Vacuum Regulator* (the Product) will be free of defects in workmanship and/or material for the following period:

Ten (10) years from date of shipment.

Should any failure to conform to this warranty appear within the applicable period, Precision Medical, Inc. shall, upon written notification thereof and substantiation that the goods have been stored, installed, maintained and operated in accordance with Precision Medical, Inc.'s instructions and standard industry practice, and that no modifications, substitutions, or alterations have been made to the goods, correct such defect by suitable repair or replacement at its own expense.

ORAL STATEMENTS DO NOT CONSTITUTE WARRANTIES.

Representative of Precision Medical, Inc. or any retailers are not authorized to make oral warranties about the merchandise described in this contract, and any such statements shall not be relied upon and are not part of the contract for sale. Thus, this writing is a final, complete and exclusive statement of the terms of that contract.

THIS WARRANTY IS EXCLUSIVE AND IS IN LIEU OF ANY WARRANTY OF MERCHANTABILITY, FITNESS FOR A PARTICULAR PURPOSE OR OTHER WARRANTY OF QUALITY, WHETHER EXPRESSED OR IMPLIED.

Precision Medical, Inc. shall not under any circumstances be liable for special, incidental or consequential damages including but not limited to lost profits, lost sales, or injury to person or property. Correction of non-conformities as provided above shall constitute fulfillment of all liabilities of Precision Medical, Inc. whether based on contract, negligence, strict tort or otherwise. Precision Medical, Inc. reserves the right to discontinue manufacture of any product or change product materials, designs, or specifications without notice.

Precision Medical, Inc. reserves the right to correct clerical or typographical errors without penalty.