

**ECE 445**

**Analysis and Design of Power  
Electronic Circuits Lab**

# Old Diode and Thyristor based Experiments

## – *Before I joined*

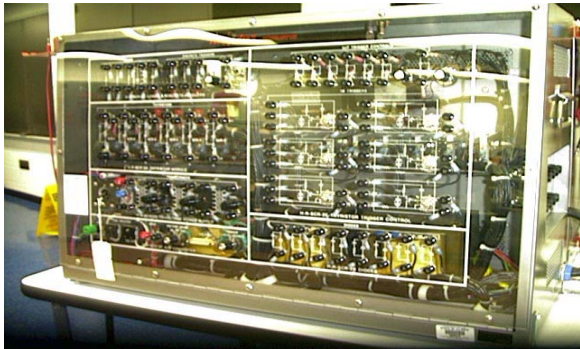

(a)

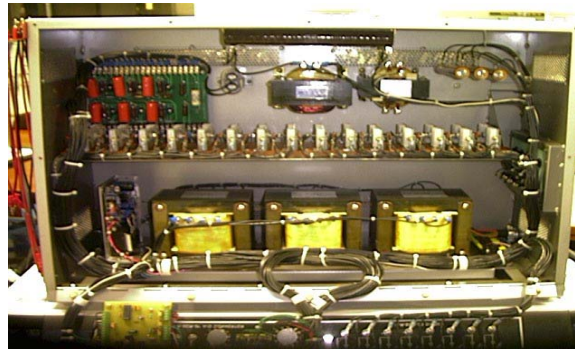

(b)

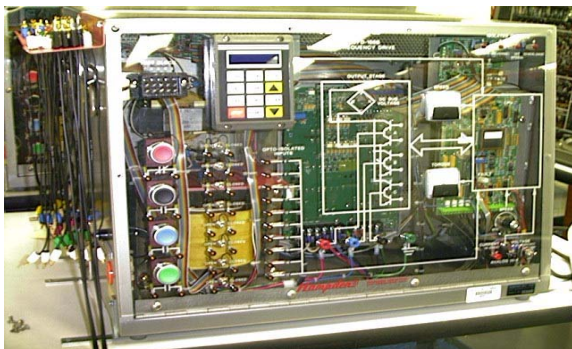

(c)

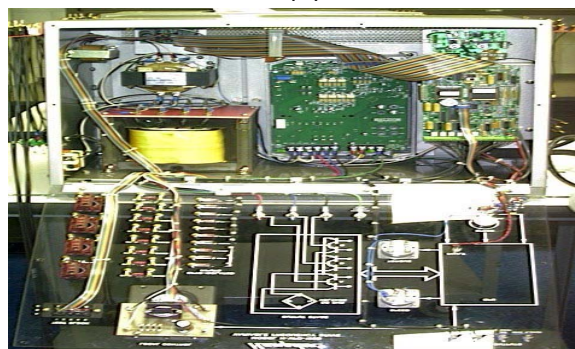

(d)

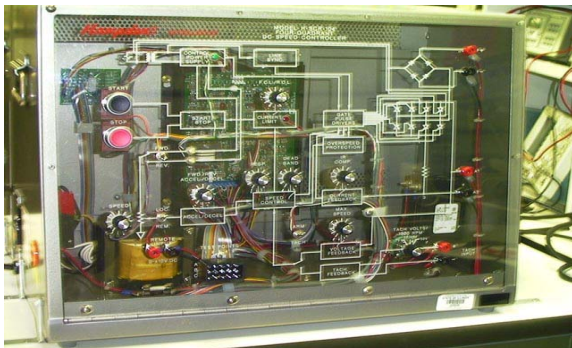

(e)

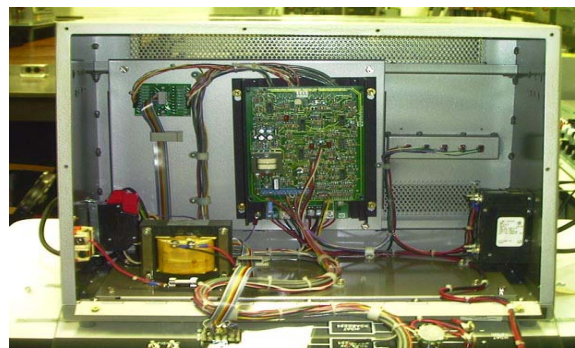

(f)

- Majority of the experiments thyristor based - obsolete
- Experiments do not reflect revised and modernized 445 curriculum
  - No modern high-speed switching circuits using MOSFETs or IGBTs
- Full bridge thyristor circuits do not work; half/split bridge configuration needs to be adopted
- Experiments are designed with focus on motor control
  - There is a setup on cycloconverter, which is hardly justified for basic 445 power electronics course
  - Expensive and bulky

# New ECE 445 Power-Pole Board

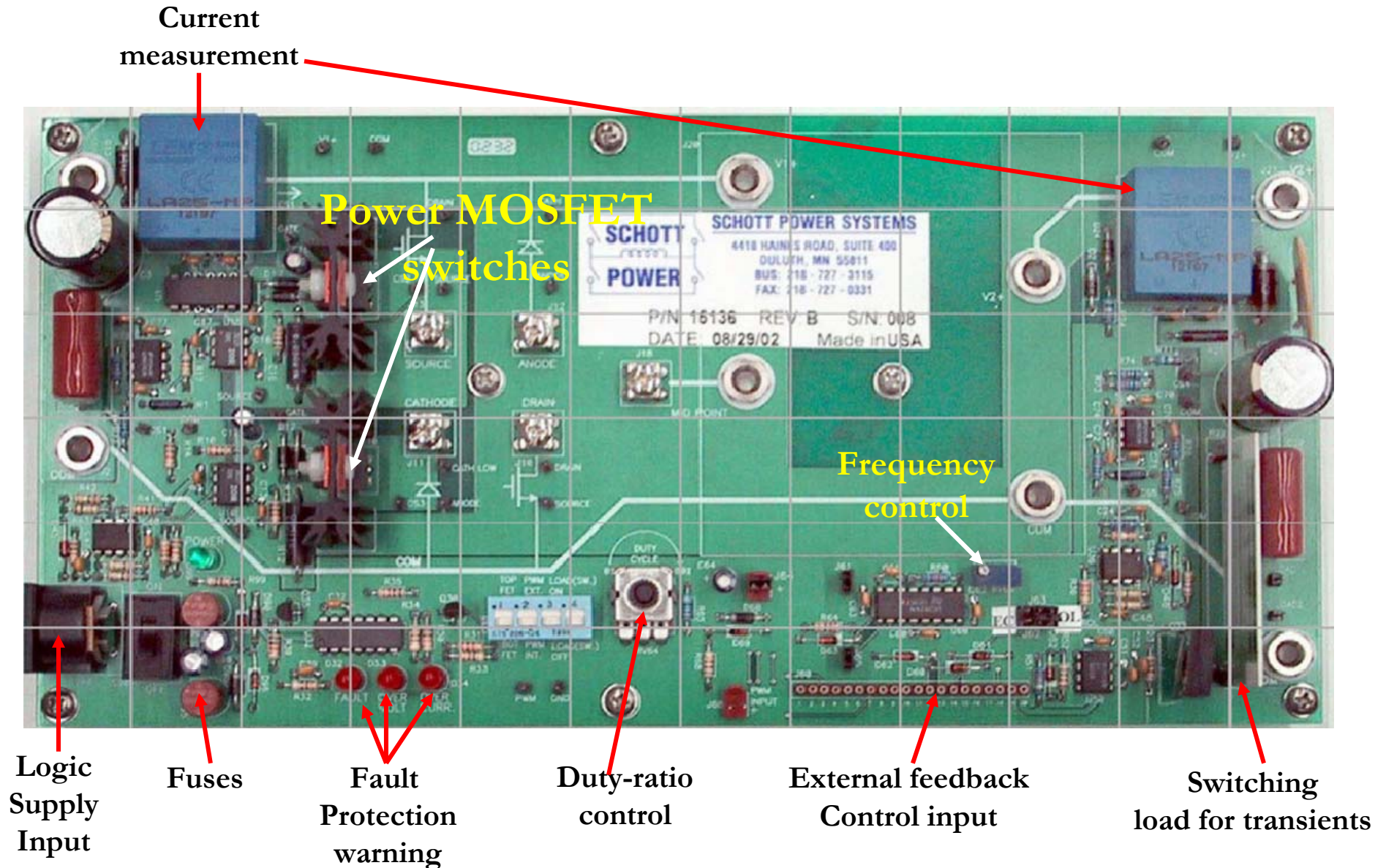

# Magnetic Boards

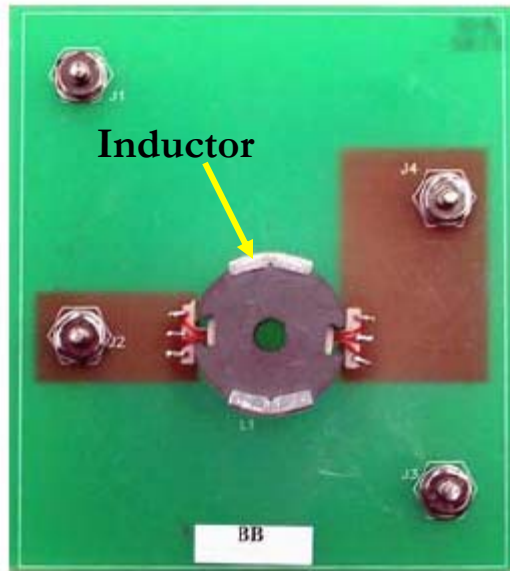

**Buck, Boost  
& Buck-boost  
Converter**

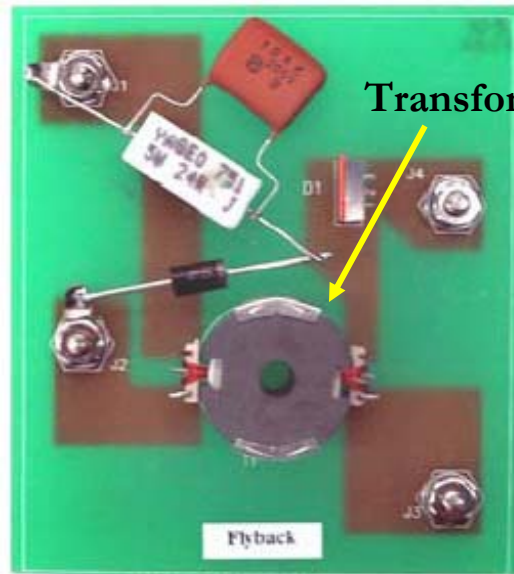

**Flyback  
Converter**

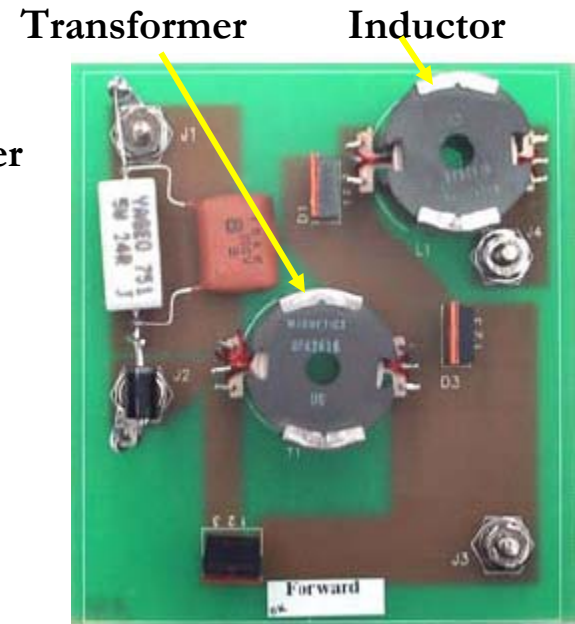

**Forward  
Converter**

# Experimental Setup

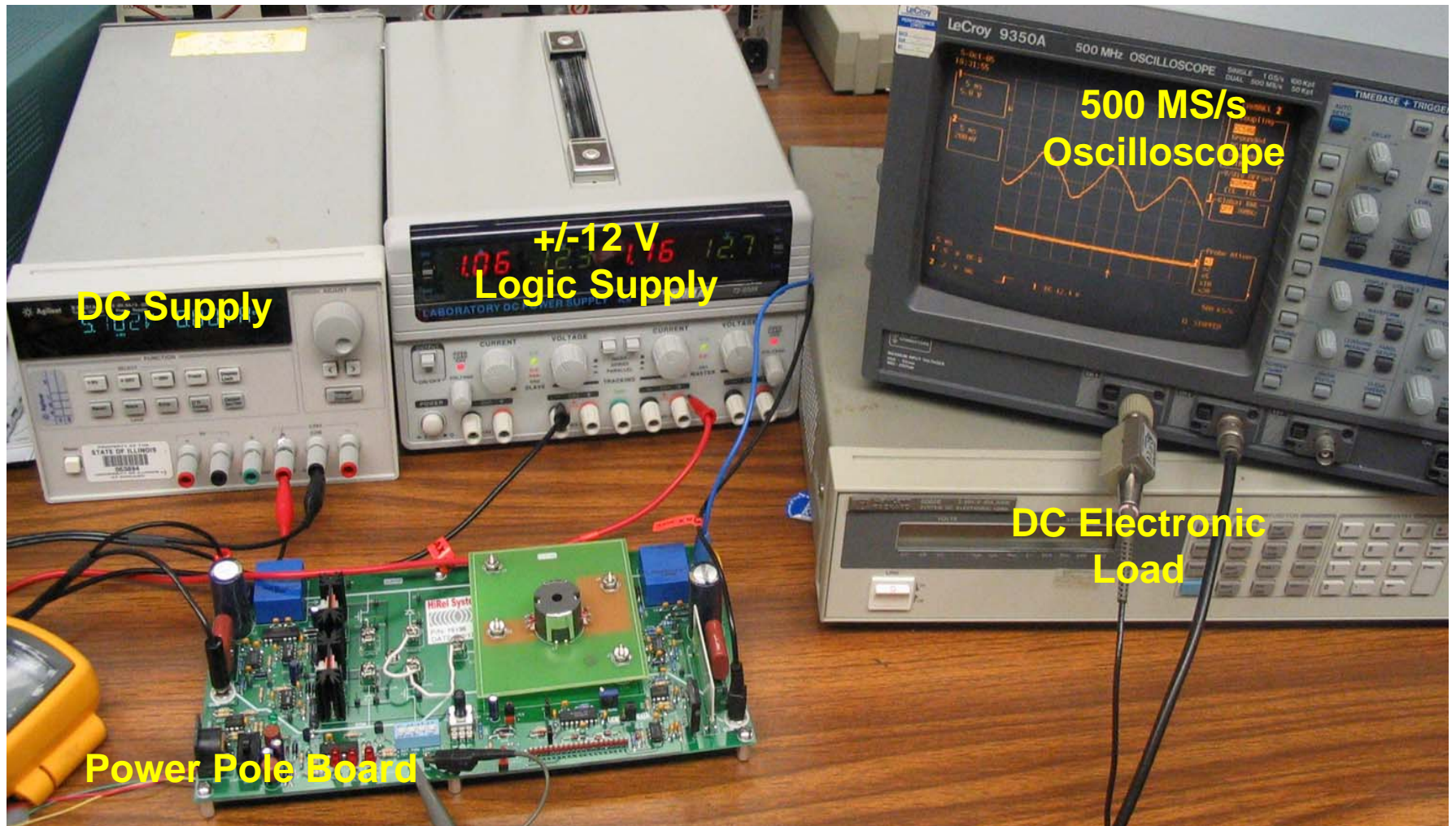

# Features of the Lab. Module

- Modular laboratory setup (**PEBB – Power Electronics Building Block**)
- Based on NSF initiative and multi-university collaboration
- Cost effective and requires less space
- Trial runs for ~2 semesters have yielded no safety problems so far
- Components supported by advanced SaberDesigner simulator models, which students use for design and validation
  
- Onboard PWM signal
- Open loop and feedback control options
- Frequency analysis
- Easy setup and configuration changes
- Safe banana plugs for input and output connections
- Maximum input voltage : 40 V DC
- Maximum operating current : 5 A DC

# New G/UG National Science Foundation Proposition

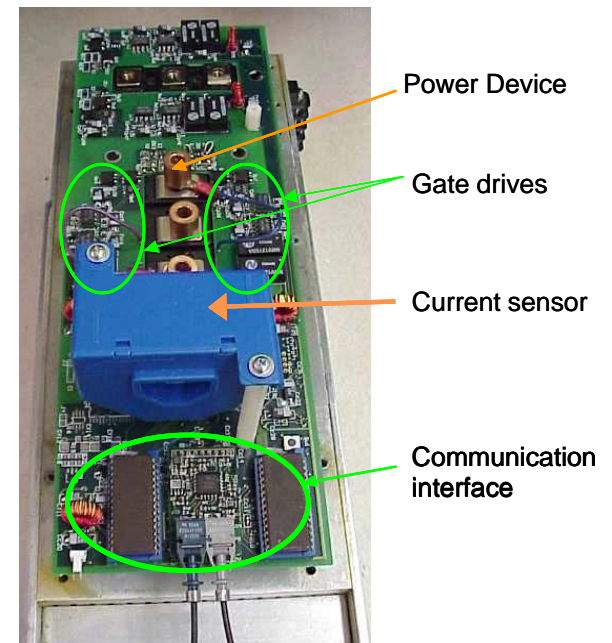
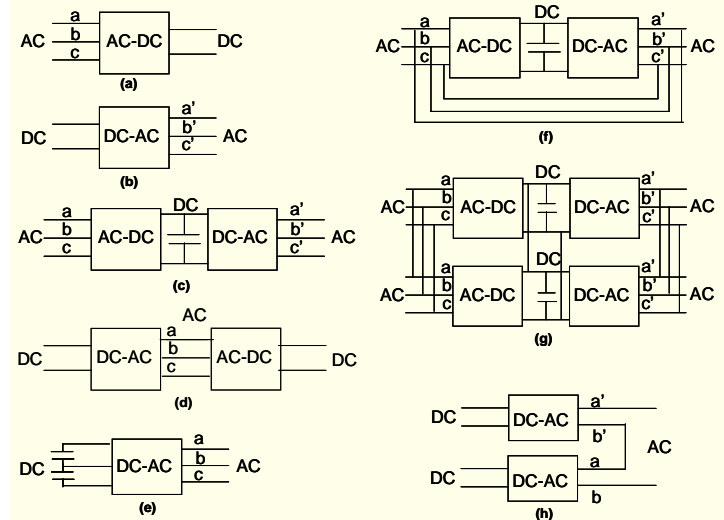
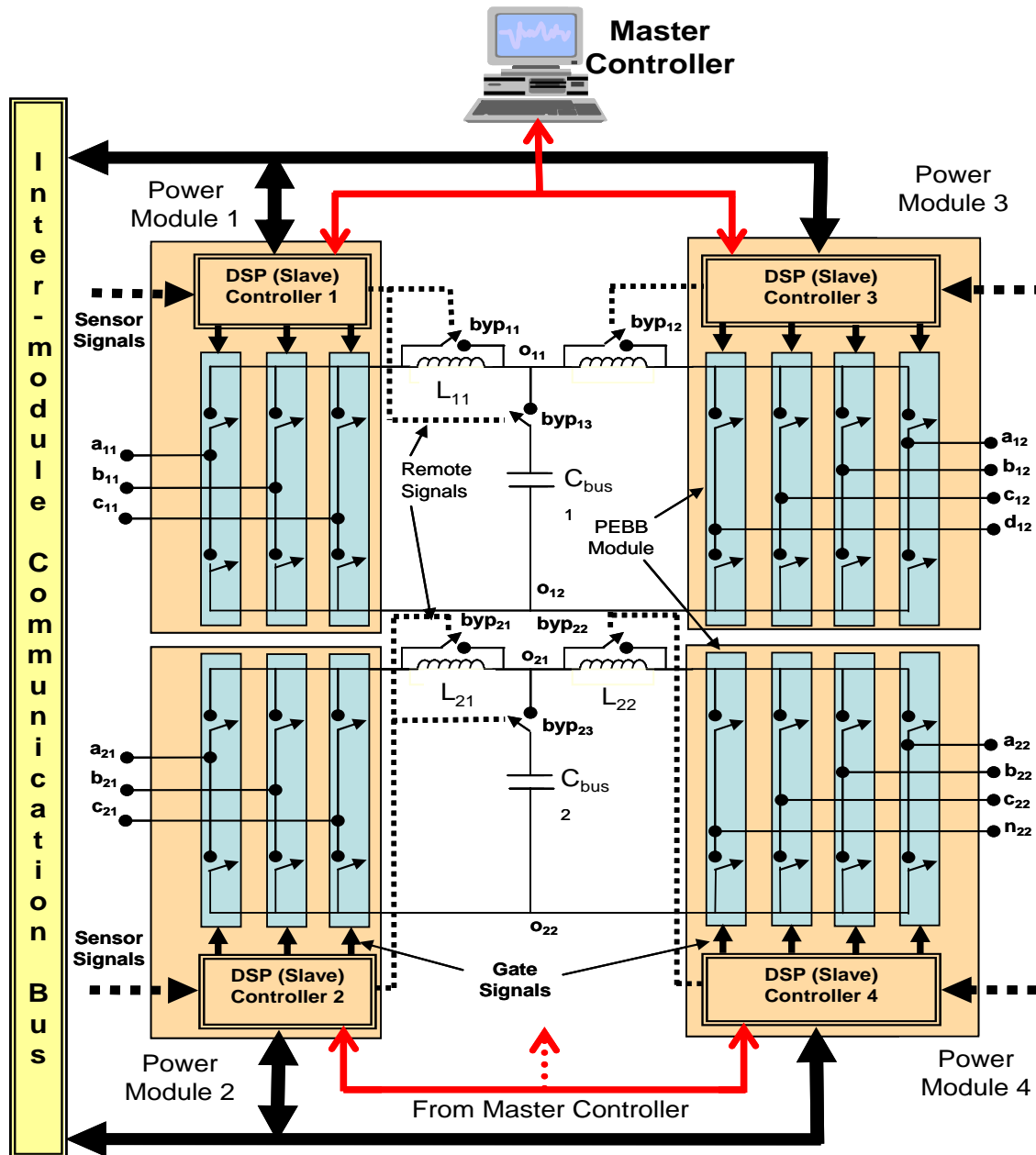

# Preliminary Discrete Setup with Support from Altera, Texas Instruments

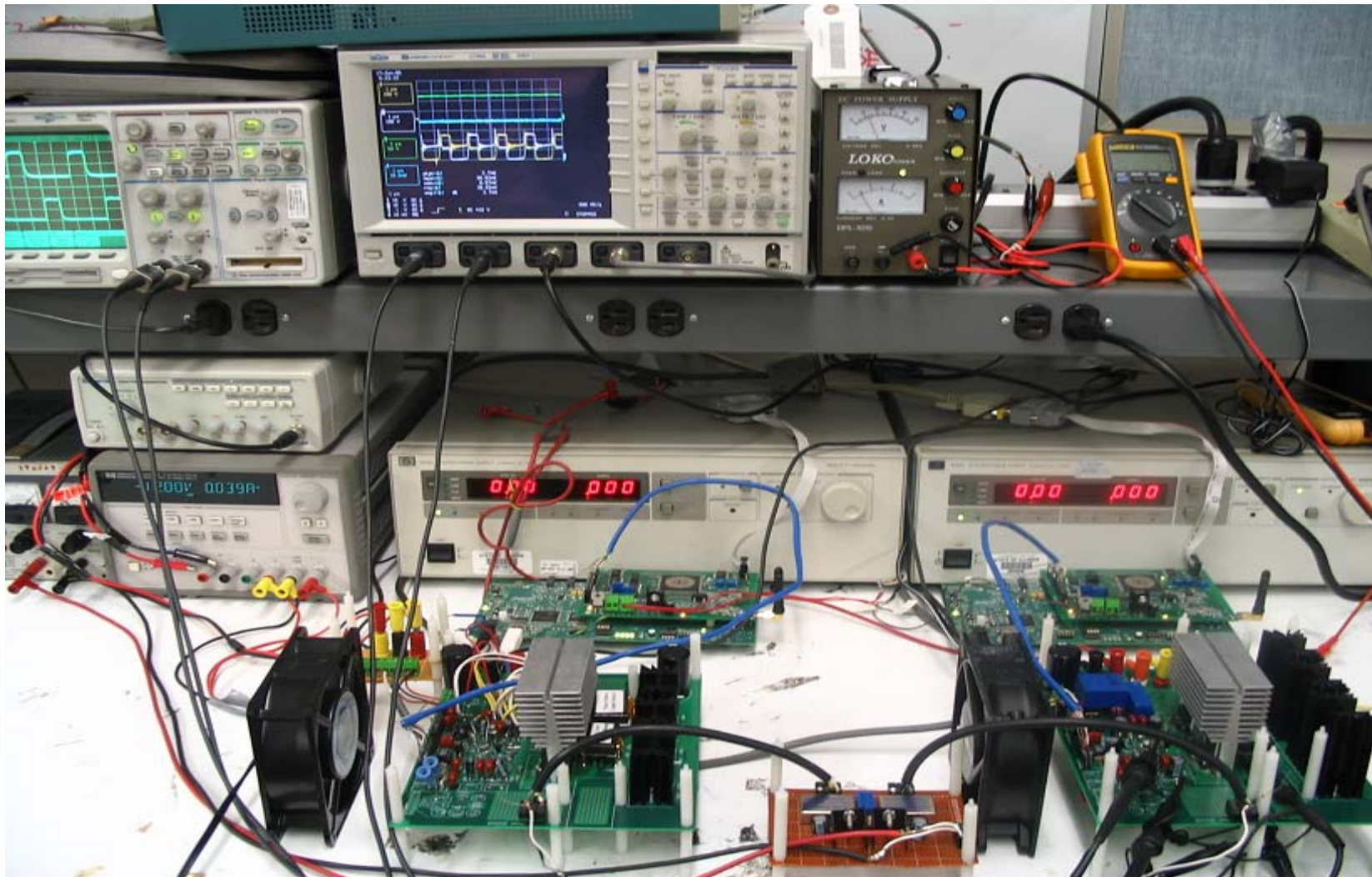



# FPGA based Motor Drive Laboratory Setup

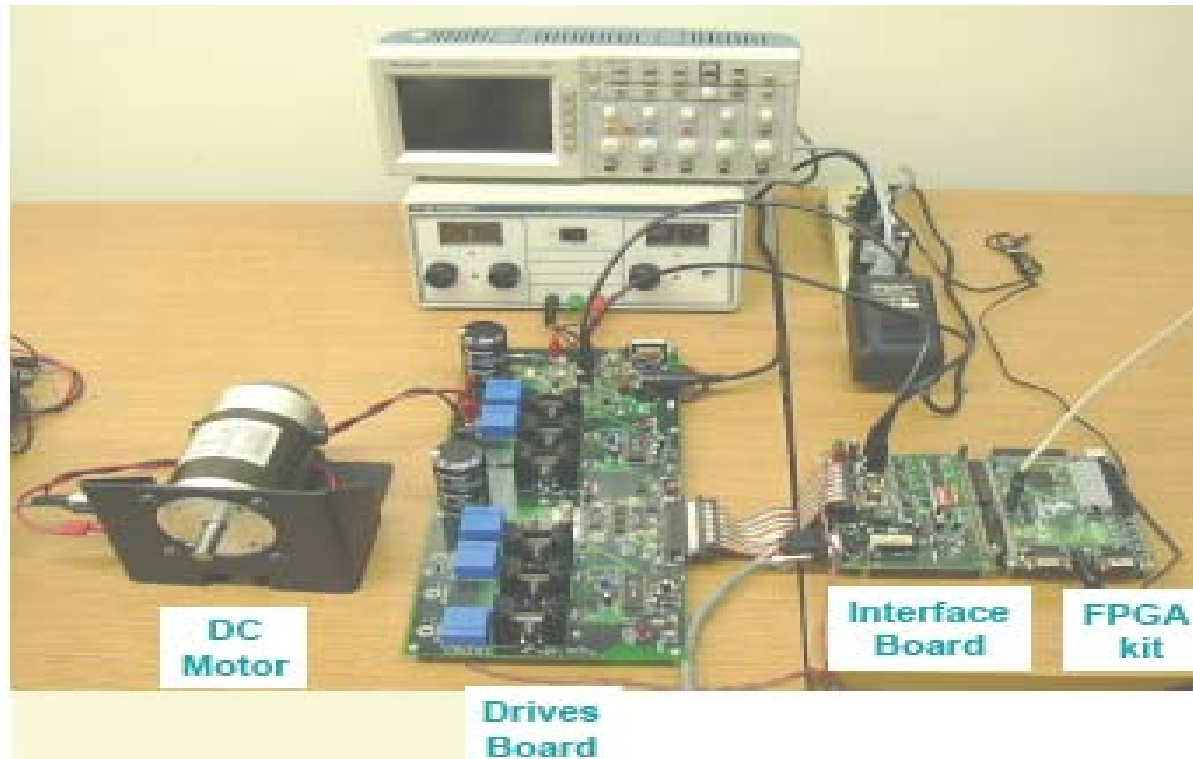

(a) Drives Board



(b) Motor Set

# Student Access to Modern Technology Makes a Difference

## UNDERGRADUATE STUDENTS



E. Duheric



G. Garcia



S. Pro



O. Rodrigues



M. Stasinopoulos



C. Stroe

## GRADUATE STUDENTS



K. Acharya



R. K. Burra

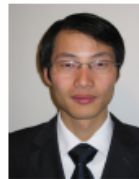

R. Huang



S. Pradhan



M. Tahir

**UIC stood 1<sup>st</sup> among U.S. Universities and 3<sup>rd</sup> in world ranking in the 2005 IEEE Future Energy Challenge Competition**

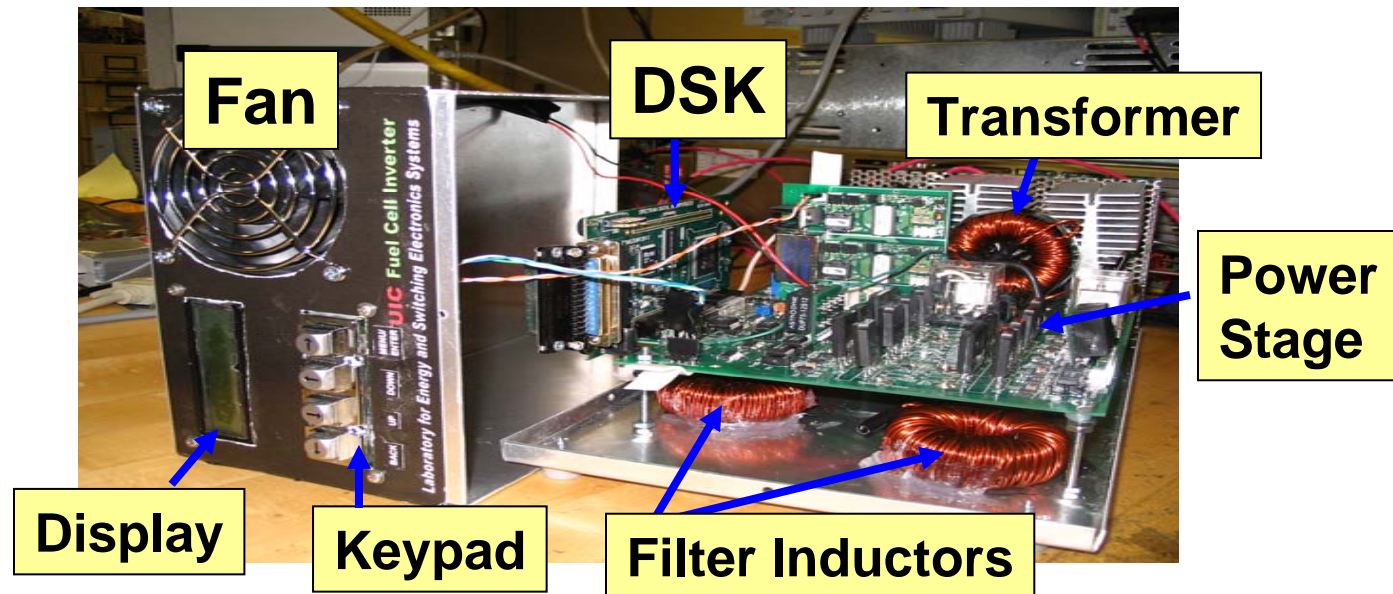

# ECE 445 Power-Pole Board

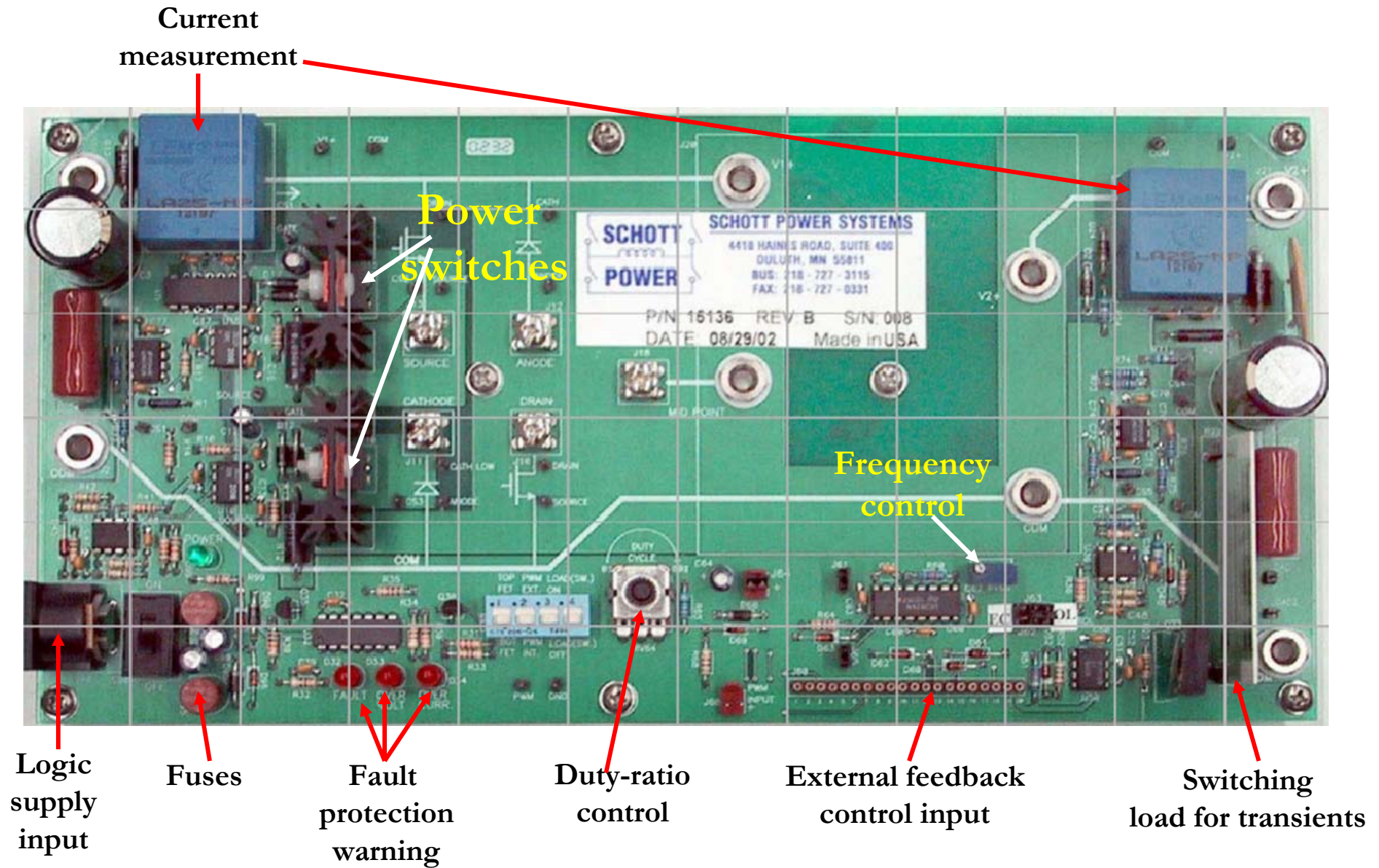

# Safety Issues

- Setup is done before powering anything up
- Probe connections can be done before powering things up
- Laboratory manual clearly outlines the safety issues to the students and safety precautions that need to be taken
- Input voltage  $< 40\text{ V}$ , maximum operating current less than 5A
- High and low-voltage logic areas are separate
  - What more can we do?
- Clearly tell the 445 students the nature of the experiments at the beginning of the course. (suggestion by Univ. of Minnesota)
- Take a safety test following NCF (formerly MAL) approach
- Transparent enclosure
- UL approved power equipments (may cost a bit more)
  - Need your inputs and help

# ECE 445 Power Electronics Laboratory User Manual

# Contents

<b>1</b>	<b>Power-pole Board Familiarization</b>	<b>5</b>
<b>2</b>	<b>Buck Converter</b>	<b>15</b>
<b>3</b>	<b>Boost Converter</b>	<b>19</b>
<b>4</b>	<b>Buck-Boost Converter</b>	<b>23</b>
<b>5</b>	<b>Flyback Converter</b>	<b>27</b>
<b>6</b>	<b>Forward Converter</b>	<b>31</b>
<b>7</b>	<b>Switching Characteristic of MOSFET and Diode</b>	<b>35</b>
<b>8</b>	<b>Voltage-Mode Control</b>	<b>39</b>
<b>9</b>	<b>Peak Current Mode Control</b>	<b>45</b>



# SAFETY PRECAUTIONS

## 1 Why is safety important ?

Attention and adherence to safety considerations is even more important in a power electronics laboratory than its required in any other undergraduate electrical engineering laboratories. Power electronic circuits can involve voltages of several hundred volts and currents of several tens of amperes. By comparison the voltages in all other teaching laboratories rarely exceed 20V and the currents hardly ever exceed a few hundred milliamps.

In order to minimize the potential hazards, we will use dc power supplies that never exceed voltages above 40-50V and will have maximum current ratings of 20A or less. Most of the time we will use dc supplies of 20V or less and 1 A or less output current capability. However in spite of this precaution, power electronics circuits on which the student will work may involve substantially larger voltages (up to hundreds of volts) due to the presence of large inductances in the circuits and the rapid switching on and off of amperes of current in the inductances. For example a boost converter can have an output voltage that can theoretically go to infinite values if it is operating without load. Moreover the currents in portions of some converter circuits may be many times larger than the currents supplied by the dc supplies powering the converter circuits. A simple buck converter is an example of a power electronics circuit in which the output current may be much larger than the dc supply current.

## 2 Potential problems presented by Power Electronic circuits

- Electrical shock may take a life.
- Exploding components (especially electrolytic capacitors) and arcing circuits can cause blindness and severe burns.
- Burning components and arcing can lead to fire.

## 3 Safety precautions to minimize these hazards

### 3.1 General Precautions

- Be calm and relaxed, while working in Lab.



- When working with voltages over 40V or with currents over 10A, there must be at least two people in the lab at all times.
- Keep the work area neat and clean.
- No paper lying on table or nearby circuits.
- Always wear safety glasses when working with the circuit at high power or high voltage.
- Use rubber floor mats (if available) to insulate yourself from ground, when working in the Lab.
- Be sure about the locations of fire extinguishers and first aid kits in lab.
- A switch should be included in each supply circuit so that when opened, these switches will de-energize the entire setup. Place these switches so that you can reach them quickly in case of emergency, and without reaching across hot or high voltage components.

### **3.2 Precautions to be taken when preparing a circuit**

- Use only isolated power sources (either isolated power supplies or AC power through isolation power transformers). This helps using a grounded oscilloscope and reduces the possibility of risk of completing a circuit through your body or destroying the test equipment.

### **3.3 Precautions to be taken before powering the circuit**

- Check for all the connections of the circuit and scope connections before powering the circuit, to avoid shorting or any ground looping, that may lead to electrical shocks or damage of equipment.
- Check any connections for shorting two different voltage levels.
- Check if you have connected load at the output.
- Double check your wiring and circuit connections. It is a good idea to use a point-to-point wiring diagram to review when making these checks.

### **3.4 Precautions while switching ON the circuit**

- Apply low voltages or low power to check proper functionality of circuits.
- Once functionality is proven, increase voltages or power, stopping at frequent levels to check for proper functioning of circuit or for any components is hot or for any electrical noise that can affect the circuit's operation.

### **3.5 Precautions while switching off or shutting down the circuit**

- Reduce the voltage or power slowly till it comes to zero.
- Switch off all the power supplies and remove the power supply connections.
- Let the load be connected at the output for some time, so that it helps to discharge capacitor or inductor if any, completely.

### **3.6 Precautions while modifying the circuit**

- Switch Off the circuit as per the steps in section 3.5.
- Modify the connections as per your requirement.
- Again check the circuit as per steps in section 3.3, and switch ON as per steps in section 3.4.

### **3.7 Other Precautions**

- No loose wires or metal pieces should be lying on table or near the circuit, to cause shorts and sparking.
- Avoid using long wires, that may get in your way while making adjustments or changing leads.
- Keep high voltage parts and connections out of the way from accidental touching and from any contacts to test equipment or any parts, connected to other voltage levels.
- When working with inductive circuits, reduce voltages or currents to near zero before switching open the circuits.
- BE AWARE of bracelets, rings, metal watch bands, and loose necklace (if you are wearing any of them), they conduct electricity and can cause burns. Do not wear them near an energized circuit.
- Learn CPR and keep up to date. You can save a life.
- When working with energized circuits (while operating switches, adjusting controls, adjusting test equipment), use only one hand while keeping the rest of your body away from conducting surfaces.



# Experiment 1

## Power-pole Board Familiarization

### 1.1 Introduction

The main feature of the Power-pole Board is the reconfigurable power-pole consisting of two MOSFETs and two diodes. The drive circuits for the MOSFETs are incorporated on the board, and so are the various protection circuits for over current and over voltage. PWM signals to control the MOSFETs can be generated onboard or supplied from an external source. The power-pole can be configured to work in various topologies using three magnetics boards (BB board for buck, boost and buck-boost converters, Flyback board for flyback converter, and Forward board for forward converter) which plug into the Power-pole Board . In addition, there is an option of doing frequency analysis of each topology by injecting a small-signal sinusoidal control voltage. The board can also be operated in voltage/current feedback mode using an external control circuit mounted on a daughter board which plugs into the Power-pole Board board.

### 1.2 Board Familiarization

The basic block diagram of the Power-pole Board is shown in Fig. 1.1 and the actual board is shown in Fig. 1.2. Please note that the location of the various components on the board are indicated in Table 1.1.

#### 1.2.1 Power-pole

The power-pole consists of MOSFETs Q10 and Q15 and diodes D10 and D15. The source of the upper MOSFET and the drain of the lower MOSFET are connected to screw terminals for external connection, and so are the anode of upper diode and the cathode of the lower diode. The voltage

Table 1.1: Locations of components on Power-pole Board

No.	Component	Ref. Des.	Location in Fig. 1.2
1	Terminal V1+	J1	A-1
2	Terminal V2+	J21	L-1
3	Terminal COM (input)	J2	A-4
4	Terminal COM (output)	J22	L-6
5	DIN connector for $\pm 12$ V signal supply	J90	A-5
6	Signal supply switch	S90	B-6
7	Signal supply +12 V fuse	F90	B-5
8	Signal supply -12 V fuse	F95	B-6
9	Signal supply LED	D99	B-5
10	Fault LED	D32	D-6
11	Over voltage LED	D33	D-6
12	Over current LED	D34	D-6
13	Upper MOSFET , diode and heat sink assembly	Q15, D15	C-2
14	Lower MOSFET , diode and heat sink assembly	Q10, D10	C-4
15	Screw terminal for upper MOSFET source	J13	D-3
16	Screw terminal for lower diode cathode	J11	D-4
17	Screw terminal for upper diode anode	J12	E-3
18	Screw terminal for lower MOSFET drain	J10	E-4
19	Screw terminal for Mid-point	J18	F-3
20	Magnetics Board plug-in space	J20	H-3
21	PWM Controller UC3824	U60	I-5
22	Duty ratio pot RV64	RV64	F-5
23	Switching frequency adjustment pot RV60	RV60	I-5
24	External PWM signal input terminal	J68	G-6
25	Selector Switch Bank	S30	E-5
26	Daughter board connector	J60	H-6
27	Switched load	R22	K-5
28	Resettable Fuse	F21	L-2
29	Control selection jumpers	J62, J63	J-5
30	Ramp select jumper	J61	H-5
31	Current limit jumper	J65	H-6
32	Small-signal ac analysis selection jumper	J64	G-5
33	Input current sensor (LEM)	CS1	B-1
34	Output current sensor (LEM)	CS5	K-2

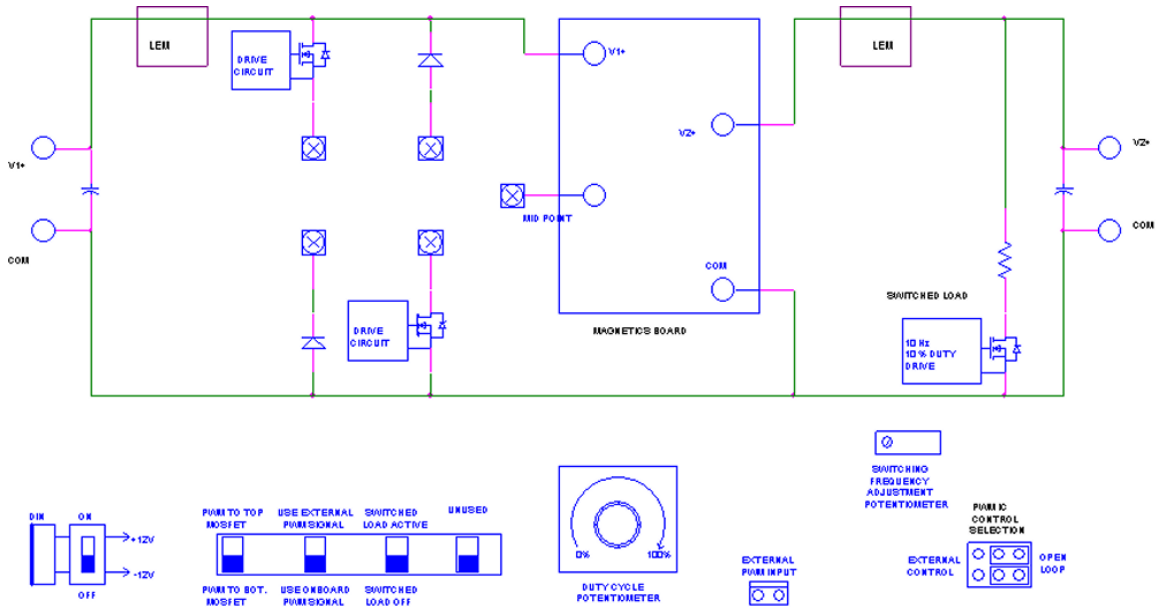

Figure 1.1: Block Diagram of Power-pole Board

Table 1.2: Test Point Details and Location on Power-pole Board

No.	Test Point	Description of Test Point	Location in Fig. 1.2
1	V1+	Terminal V1+	C-1
2	V2+	Terminal V2+	K-1
3	CS1	Input current	B-4
4	CS2	Upper MOSFET source current	D-2
5	CS3	Lower diode or lower MOSFET source current	D-4
6	CS4	Output Capacitor Current	K-3
7	CS5	Output current	K-4
8	CS LOAD 1	Switched Load Voltage +ve	L-5
9	CS LOAD 2	Switched Load Voltage -ve	L-5
10	PWM	PWM Signal	E-6
11	DRAIN (upper MOSFET )	Upper MOSFET drain	D-2
11	SOURCE (upper MOSFET )	Upper MOSFET source	D-2
12	DRAIN (lower MOSFET )	Lower MOSFET drain	E-4
12	SOURCE (lower MOSFET )	Lower MOSFET source	E-4
13	ANODE (upper diode)	Upper diode anode	E-2
13	CATHODE (upper diode)	Upper diode cathode	E-2
14	ANODE (lower diode)	Lower diode anode	D-4
14	CATHODE (lower diode)	Lower diode cathode	D-4
15	GATE (upper MOSFET )	Gate of upper MOSFET	C-2
16	GATE (lower MOSFET )	Gate of lower MOSFET	C-4

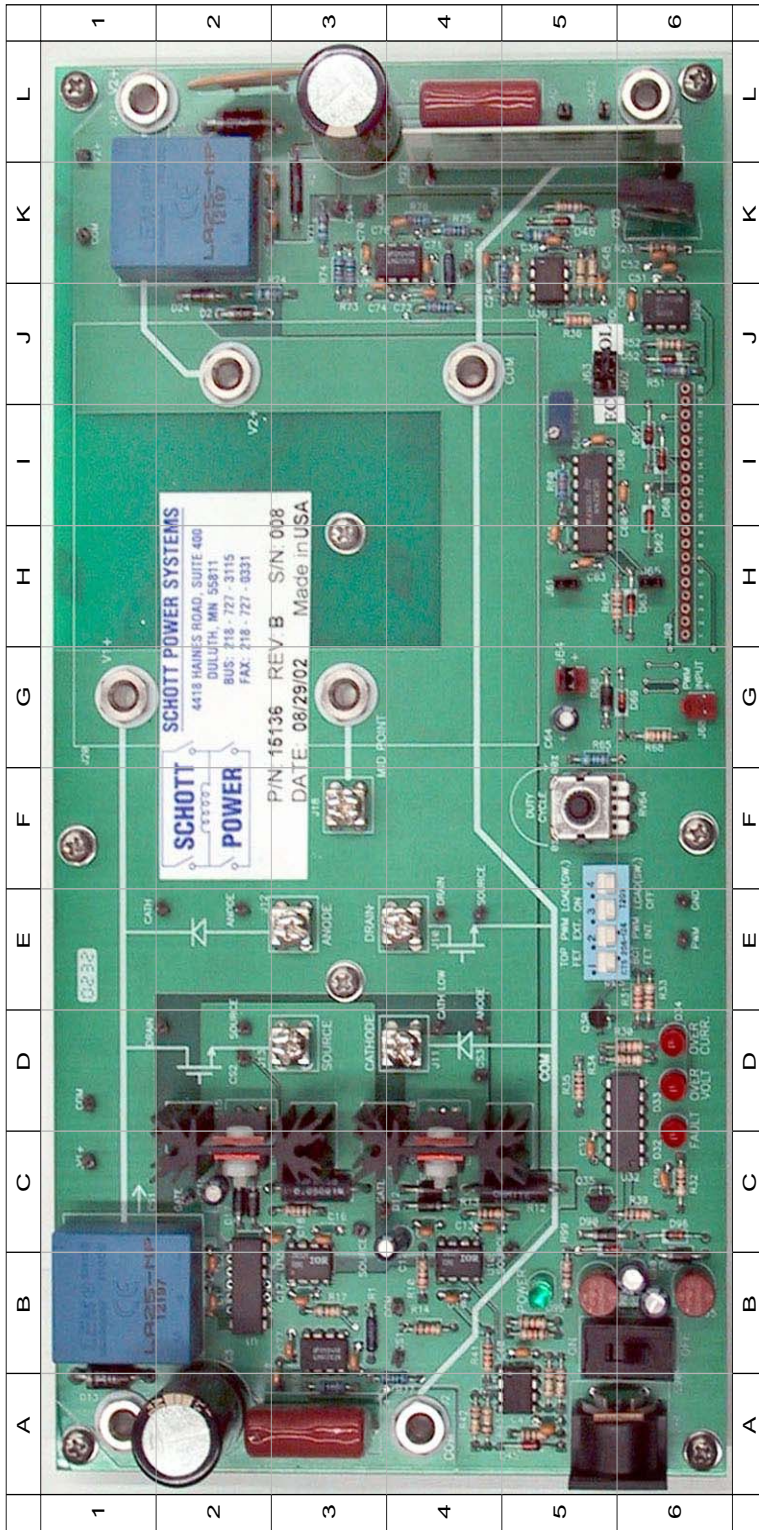

Figure 1.2: Power-pole Board

and current waveforms at the terminals of the MOSFETs and diodes can be observed.

**Note** : Take care whenever you are using oscilloscope probes to measure voltage. If the measurement reference potential is different to the oscilloscope reference potential, you must use **differential probe**.

To observe the voltage across the upper MOSFET ,

- Connect the positive and negative terminals of a **differential probe** to the *DRAIN* and *SOURCE* of upper MOSFET .

To observe the upper MOSFET source current,

- Connect the positive and negative terminals of a **differential probe** to terminals *CS2* and *SOURCE* (D-2 in Fig. 1.2) of upper MOSFET . The current sense resistor value is  $0.05 \Omega$ .

To observe the voltage across the lower MOSFET ,

- Connect an oscilloscope probe to the *DRAIN* and its ground to the *SOURCE* (E-4 in Fig. 1.2) of the lower MOSFET .

To observe the lower MOSFET source current,

- Connect an oscilloscope probe to terminal *CS3* and its ground to the *SOURCE* (E-4 in Fig. 1.2) of the lower MOSFET . The current sense resistor value is  $0.05 \Omega$ . The same test points also measure the lower diode current if that is included in the circuit.

To observe the voltage across the upper diode,

- Connect the positive and negative terminals of a **differential probe** to terminal *CATH* and *ANODE* (E-2 in Fig. 1.2) of the upper diode.

To observe the voltage across the lower diode,

- Connect an oscilloscope probe to *CATH LOW* and its ground to the *ANODE* of the lower diode (D-4 in Fig. 1.2).

### 1.2.2 Magnetics Boards

To build various converters using the Power-pole Board , three plug in boards are provided:



1. BB Board (Fig. 1.3(a)): For buck, boost and buck-boost converters
2. Flyback Board (Fig. 1.3(b)): For flyback converter
3. Forward Board (Fig. 1.3(c)): For forward converter

How to use these boards will be described in the subsequent experiments.

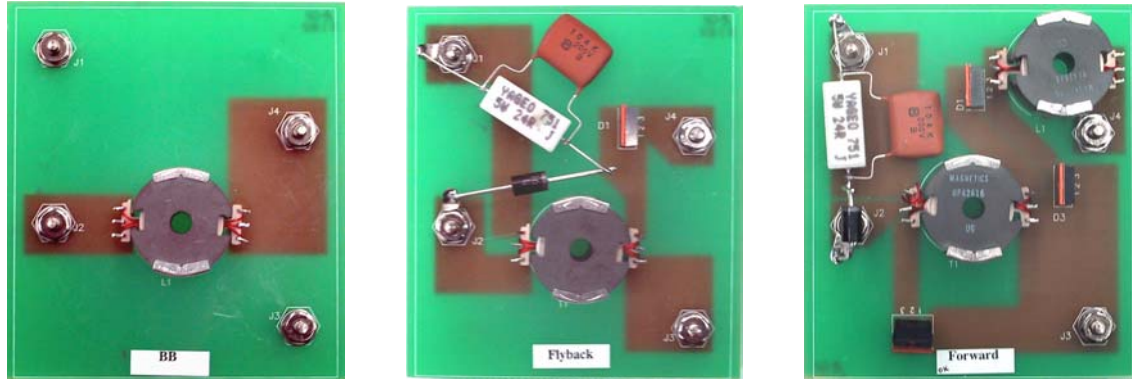

(a) BB Board

(b) Flyback Board

(c) Forward Board

Figure 1.3: Magnetics Boards

### 1.2.3 Signal Supply

$\pm 12$  volts signal supply is required for the MOSFET drive circuits and also the measurement and protection circuits. This is obtained from a wall-mounted isolated power supply, which plugs into the DIN connector J90 (A-5 in Fig. 1.2). Switch S90 (B-6 in Fig. 1.2) controls the signal power to the board. Each time a fault occurs, turn off and turn on this switch to reset the board. The green LED D99 (B-5 in Fig. 1.2) indicates if the +12 V signal supply is available to the board. Fuses F90 (B-5 in Fig. 1.2) and F95 (B-6 in Fig. 1.2) provide protection for the +12 V and -12 V supplies respectively.

### 1.2.4 Load

Any external load is to be connected across terminals V2+ and COM (L-1 and L-6 in Fig. 1.2).

An onboard switched load is provided to facilitate the observation of the transient response of any converter built using the power-pole. Thus it is possible to periodically switch in and out a 20  $\Omega$  load (K-4 to K-6 in Fig. 1.2). The frequency and duty ratio of this load is fixed at 10 Hz and 10%.

To select the switched load,

- Put switch 3 of selector switch bank S30 (E-5 in Fig. 1.2) to the top position (Load(SW) ON).

In order to observe the switched load current,

- Connect the positive and negative terminals of a **differential probe** to *CS LOAD 1* and *CS LOAD 2* (L-5 in Fig. 1.2). This measures the voltage across the 20  $\Omega$  resistor.
- Switched load current is the measured voltage divided by 20.

### 1.2.5 Input/Output Voltage Measurement

Test points for input/output voltage measurements are provided on the Power-pole Board .

For input voltage measurement,

- Connect the oscilloscope probe to test point *V1+* (C-1 in Fig. 1.2) and its ground to *COM* (D-1 in Fig. 1.2).

For output voltage measurement,

- Connect the oscilloscope probe to test point *V2+* (K-1 in Fig. 1.2) and its ground to *COM* (L-1 in Fig. 1.2).

### 1.2.6 Current Measurement

LEM current sensors (B-1, K-2 in Fig. 1.2) are provided to measure the input and output currents. The input current sensor is located after the input filter capacitor, and the output current sensor is located before the output filter capacitor. Calibration of the current sensors is such that for 1A current flowing through each, the output is 0.5 V. These signals are amplified by a factor of 2 and are brought out to the daughter board connector J60, for use in feedback current control. Currents through the MOSFETs and output capacitor are measured using current sense resistors. Refer to Table 1.2 for details of the various current measurement test points.

To measure input current,

- Connect oscilloscope probe to *CS1* (B-1 in Fig. 1.2) and its ground to *COM* (D-1 in Fig. 1.2).

To measure output current,

- Connect oscilloscope probe to *CS5* (K-2 in Fig. 1.2) and its ground to *COM* (L-1 in Fig. 1.2) .

To measure output capacitor ripple current,

- Connect oscilloscope probe to *CS4* (K-3 in Fig. 1.2) and its ground to *COM*. The current sense resistor value is  $0.1 \Omega$ .

### 1.2.7 MOSFET Drive Circuit

The power-pole MOSFETs are driven by high side drivers IR2127. These drivers have in-built overcurrent protection using a current-sense resistor for each MOSFET (see locations C-3 and C-5 in Fig. 1.2). The voltage across these sense resistors can be observed using test points provided on the board.

To see the upper MOSFET current,

- Connect the positive and negative terminals of a **differential probe** to *CS2* and *SOURCE* of upper MOSFET .

To see the lower MOSFET current,

- Connect an oscilloscope probe to *CS3* and its ground to *SOURCE* of lower MOSFET .

Note: The lower diode current can also be observed using test point *CS3*. However the upper diode current cannot be observed.

### 1.2.8 PWM Signal Generation

PWM signals required for the MOSFETs can be generated using the on-board PWM controller UC3824 (I-5 in Fig. 1.2). There is also an option to supply PWM signals from an external source.

To use the onboard PWM,

- Put switch 2 of the selector switch bank S30 (E-5 in Fig. 1.2) to its bottom position (PWM INT.).

To use external PWM,

- Put switch 2 of the selector switch bank S30 to its top position (PWM EXT.).

- Connect the external PWM signal to the terminal J68 (G-6 in Fig. 1.2).

While using the onboard PWM for operation of the power-pole in open-loop, the duty ratio can be controlled using pot RV64 (F-5 in Fig. 1.2). The duty ratio can be varied from 4% to 98%. The frequency of the PWM can be adjusted using the trim pot RV60 (I-5 in Fig. 1.2).

There is a provision for providing an external ramp to the UC3824 IC. This is useful for peak current mode control. For this, remove jumper J61 (H-5 in Fig. 1.2) and use the RAMP pin on daughter board connector J60.

### 1.2.9 Frequency Analysis

Frequency analysis of any converter built using the power-pole can be done by injecting a low voltage sinusoidal signal at jumper J64 (G-5 in Fig. 1.2). To do this,

- Remove jumper J64.
- Connect the small signal sinusoidal source at the jumper terminal J64.

Note: J64 is to be shorted in all other modes of operation.

### 1.2.10 Power-pole Board in Feedback Control Mode

The power-pole board can be operated in either open or closed loop and is selected by jumpers J62 and J63 (J-5 in Fig. 1.2). For open loop operation,

- Keep J62 and J63 in the righthand positions.

Closed loop operation will be described in the relevant experiment.



# Experiment 2

## Buck Converter

### 2.1 Objective

The objective of this experiment is to study the characteristics of a simple buck converter. The circuit will be operated under continuous current mode (CCM) and open loop conditions (no feedback). Our main goal will be to compare the theoretical results with the experimental results .

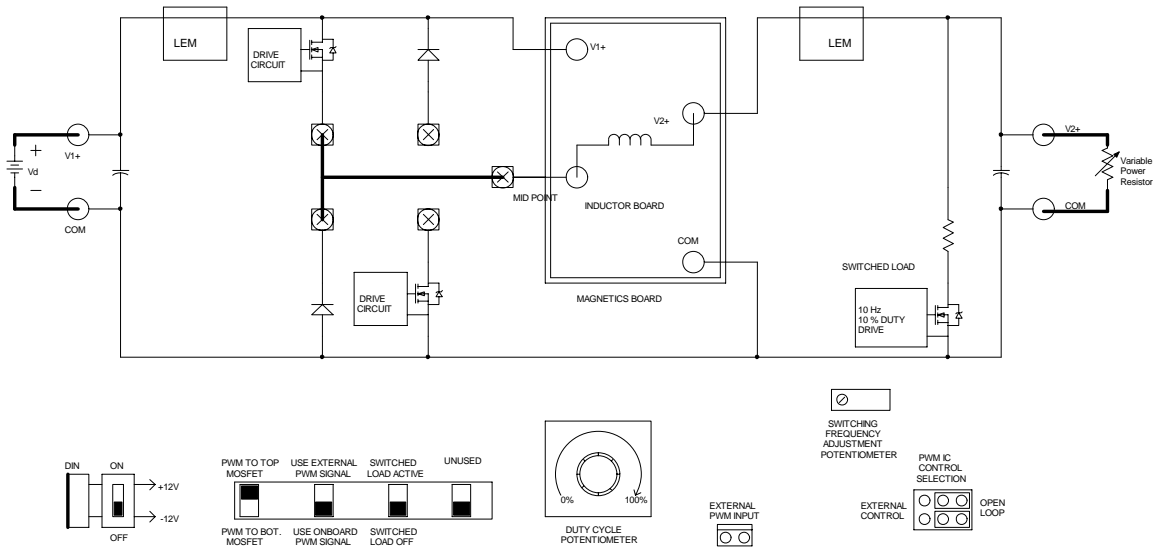

Figure 2.1: Schematic of Buck Converter

## 2.2 Preparing the Setup

Make the connections on the power-pole board as shown in Fig. 2.1 to use the upper MOSFET and the lower diode.

- Use the magnetics board BB board for the buck converter circuit. The inductor is  $100\ \mu\text{H}$ .
- Use a variable load resistor ( $R_L$ ) as a load.
- Use onboard PWM signals.
- Connect the  $\pm 12$  signal supply at the *DIN* connector. Signal supply switch S90 should be OFF.

## 2.3 Checks before powering the circuit

- Check the circuit connections as per the schematics.
- Have your circuit checked by your *Lab Instructor*.

## 2.4 Powering the Circuit

- Switch ON the signal supply. Check for green LED.
- Adjust the duty ratio to 50%.
- Adjust the switching frequency to 100kHz.
- Apply input voltage  $V_d$  of 15 volts at terminals V1+ and COM.

## 2.5 Measurement and Waveforms

Take the following measurements,

### 2.5.1 Varying Duty Ratio

- Set the duty ratio at 50%, switching frequency at 100kHz and  $R_L = 10\Omega$ .
- Vary the duty ratio from 10 % to 90 % (in steps of 10%).
- Measure the average output voltage for the corresponding duty ratio.

- Calculate the theoretical average output voltage for the corresponding duty ratios.
- Observe and make a copy of the output ripple voltage, inductor current and capacitor current waveforms.

### 2.5.2 Varying Switching Frequency

- Set the duty ratio to 50 %.
- Measure the peak-peak output ripple voltage.
- Observe and make a copy of the inductor current ( $CS5$ ) and capacitor current ( $CS4$ ) waveforms.
- Repeat the above procedure for different switching frequencies ( $40kHz$ ,  $60kHz$ ,  $80kHz$ ). Make sure that output voltage ( $V2+$ ) is maintained at  $7.5V$ .

### 2.5.3 Varying Load

- Set the switching frequency at  $100kHz$  and duty ratio at 50%.
- Set the load resistance  $R_L = 10 \Omega$ .
- Add some extra load and observe and make a copy of the inductor current waveform.
- Keep increasing the load, until the buck converter enters discontinuous current mode operation. Note down the average inductor current value when the converter starts entering discontinuous current mode of operation.
- Observe and make a copy of the output voltage, voltage across the MOSFET and diode.

### 2.5.4 Determining Efficiency

Determine the efficiency of the buck converter at frequencies of  $40kHz$ ,  $60kHz$ ,  $80kHz$  and  $100kHz$ .

- Set duty ratio at 50%.
- Set load resistance  $R_L = 10 \Omega$ .
- Measure the average output current  $I_o$ .
- Measure the average input current  $I_i$ .
- Measure the average output voltage  $V2+$ .



- Measure the average input voltage  $V_d$ .
- Calculate the efficiency of the buck converter for different frequencies using the above measurements.

## 2.6 Lab Report

The lab report should have a brief abstract detailing what has been done in the experiment. The remaining part of the report should consist of the information asked below along with any discussion you feel is necessary.

- Attach a graph of duty ratio versus output voltage ( $V_{2+}$ ) using data obtained in section 2.5.1. Also plot the theoretically calculated results on the same graph. Compare the two plots and comment about how the buck converter works as a variable dc step down transformer.
- Plot the peak-peak ripple in the output voltage versus switching frequency using data obtained in section 2.5.2. Plot the theoretical results on the same graph. Compare the two plots. Comment on why you were asked to maintain the average output voltage constant.
- Attach a copy of the inductor current ( $CS5$ ) and capacitor current ( $CS4$ ) waveforms obtained in section 2.5.2. Explain the relation between the two currents.
- Attach a copy of the output voltage and inductor current waveforms obtained in section 2.5.3. Compare with the theoretically estimated waveforms.
- Plot efficiency versus frequency using the data obtained in section 2.5.4. Comment on the results you obtain.

# Experiment 3

## Boost Converter

### 3.1 Objective

The objective of this experiment is to study the characteristics of a simple boost converter. The circuit will be operated under CCM and openloop condition. Our main goal is to compare the theoretical results with the experimental results.

**Note :** It is important that care is taken while doing the boost converter experiment using the power-pole board. The input and output terminals in the case of the boost converter are interchanged as compared to that of the buck converter. V2+ & COM is the input and V1+ & COM is the output.

### 3.2 Preparing the Setup

Make the connections of the power-pole board as shown in Fig. 3.1 to use the lower MOSFET and the upper diode.

- Use the BB magnetics board for the boost circuit. The inductor is 100  $\mu\text{H}$ .
- Use a variable load resistor as a load.
- Connect the  $\pm 12$  signal supply to the *DIN* connector. Signal supply switch S90 should be OFF.

### 3.3 Checks before powering the circuit

- Check the circuit connections as per the schematics.

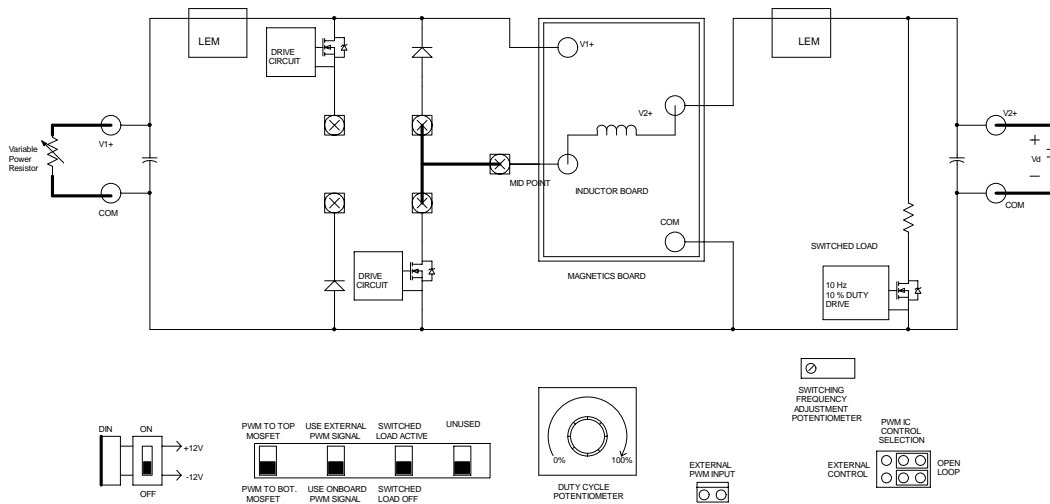

Figure 3.1: Schematic of Boost Converter

- Confirm that you have connected the input and output terminals correctly to source and load as shown in Fig. 3.1.
- Have your circuit checked by your *Lab Instructor*.

### 3.4 Powering the Circuit

- Switch ON the signal supply. Check for green LED.
- Set the duty ratio to its minimum.
- Set  $R_L = 50\Omega$ .
- Adjust the switching frequency to 100kHz.
- Apply input voltage  $V_d$  of 10 volts at terminals  $V2+$  and  $COM$ .

### 3.5 Measurements

Take the following measurements,

#### 3.5.1 Varying Duty Ratio

- Vary the duty ratio from minimum to 70% (in steps of 10%).

- Measure the average DC load voltage ( $V_{I+}$ ) for the corresponding values of duty ratio .
- Calculate the theoretical average output voltage for the corresponding duty ratios.
- Compare the observed average output voltage results with the calculated ones.

### 3.5.2 Varying Switching Frequency

- Set the duty ratio to 50%, switching frequency to 100kHz,  $R_L = 50\Omega$ .
- Observe and make a copy of the input current ( $CS5$ ) ripple waveform.
- Observe and make a copy of the output voltage ( $V_{I+}$ ) ripple waveform.
- Calculate the peak-peak input current ripple.
- Repeat the above procedure for different switching frequencies (say 40kHz, 60kHz, 80kHz).

### 3.5.3 Varying Load

- Set the duty ratio to 35%,  $R_L = 50\Omega$  and switching frequency to 100kHz.
- Keep increasing the load until the converter enters into the discontinuous conduction mode.
- Observe and make a copy of the input current to identify that the boost converter has gone into discontinuous conduction mode.
- Observe and make a copy of the voltage across MOSFET , voltage waveform across diode (Use differential probe).

### 3.5.4 Determining Efficiency

- Set the duty ratio to 50%.
- Adjust the load resistance so that load current is 0.4A.
- Measure the efficiency at switching frequencies of 40kHz, 60kHz, 80kHz, 100kHz.

## 3.6 Lab Report

The lab report should have a brief abstract detailing what has been done in the experiment. The remaining part of the report should consist of the information asked below along with any discussion you feel is necessary.

- Attach a graph of duty ratio versus output voltage using the data obtained in section 3.5.1. Also plot the theoretically calculated results on the same graph. Compare the two plots. Comment about how the boost converter works as a variable dc step-up transformer.
- Plot the peak-peak ripple in the output voltage versus switching frequency using the data obtained in section 3.5.2. Plot the theoretical results on the same graph. Compare the two graphs and comment.
- Attach a copy of the inductor current ( $i_{L5}$ ) waveform obtained in section 3.5.2. Plot the experimental and theoretically estimated input ripple current on the same graph. Compare the two graphs and comment.
- Plot efficiency versus frequency using the data obtained in section 3.5.4. Comment on the results you obtain.
- Compare and comment on the efficiencies of the buck converter (obtained in Experiment 2) and the boost converter.

## Experiment 4

# Buck-Boost Converter

### 4.1 Objective

The objective of the experiment is to study the characteristics of the simple buck-boost converter. The circuit will be operated under CCM and openloop conditions. Our main goal is to compare the theoretical results with the experimental results.

**Note :** It is important that care is taken while doing the buck-boost converter experiment using the power-pole board. The input and output terminals in the case of the buck-boost converter are different as compared to that of the buck or boost converters.

### 4.2 Preparing the Setup

Make the connections for the power-pole board as shown in Fig. 4.1

- Use the BB magnetics board for the buck-boost converter circuit. The inductor value is  $100 \mu\text{H}$ .
- Use a variable load resistor as a load.
- Connect the  $\pm 12$  signal supply to the *DIN* connector. Signal supply switch S90 should be OFF.

### 4.3 Checks before powering the circuit

- Check the circuit connections as shown in Fig. 4.1.

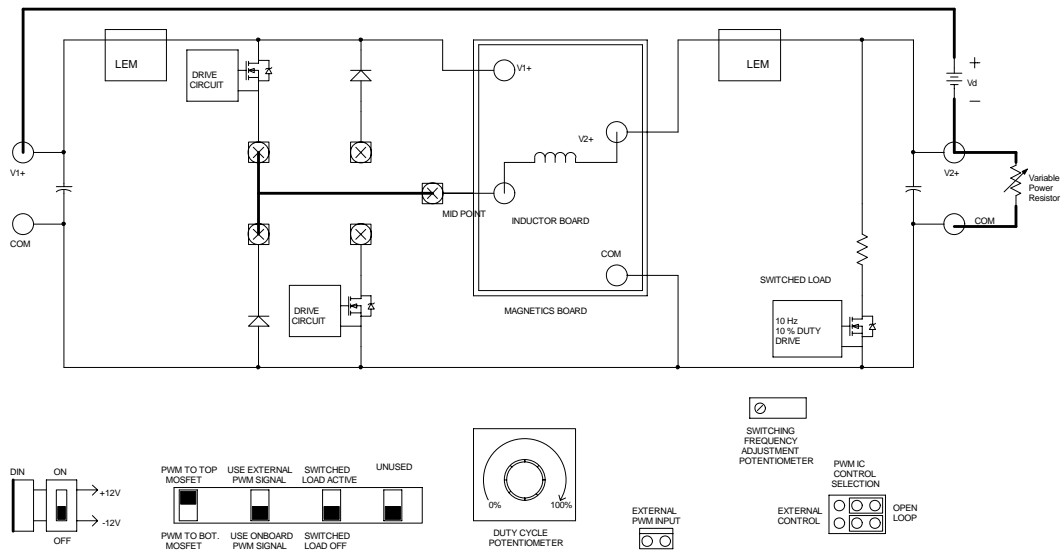

Figure 4.1: Schematic of Buck-Boost Converter

- Confirm that you have connected the input and output terminals correctly to source and load as shown in Fig. 4.1.
- Have your circuit checked by your *Lab Instructor*.

#### 4.4 Powering the Circuit

- Switch ON the signal supply. Check for green LED.
- Set the duty ratio to its minimum.
- Set  $R_L = 50\Omega$ .
- Adjust the switching frequency to 100kHz.
- Apply input voltage  $V_d$  of 10 volts at the terminals  $V1+$  and  $V2+$ .

#### 4.5 Measurements

Take the following measurements,

##### 4.5.1 Varying Duty Ratio

- Vary the duty ratio from minimum to 70% (in steps of 10%).

- Measure the average DC load voltage ( $V_{2+}$ ) for the corresponding values of duty ratio.
- Calculate the average theoretical DC output voltage for the corresponding duty ratios.
- Compare the observed average output voltage results with the calculated ones.

#### 4.5.2 Varying Switching Frequency

- Set the duty ratio to 50%, switching frequency to 100kHz,  $R_L = 50\Omega$ .
- Observe and make the copy of the inductor current ( $CS5$ ) ripple waveform.
- Observe and make the copy of the output voltage ( $V_{2+}$ ) ripple waveform.
- Calculate the peak-peak inductor current ripple.
- Repeat the above procedure for different switching frequencies (say 40kHz, 60kHz, 80kHz).

#### 4.5.3 Varying Load

- Set the duty ratio to 50%,  $R_L = 50\Omega$  and switching frequency to 100kHz.
- Keep increasing the load until the converter enters into the discontinuous conduction mode.
- Observe and make a copy of the inductor current ( $CS5$ ) to identify that the buck-boost converter has gone into discontinuous conduction mode.
- Observe and make a copy of the voltage across MOSFET (Use differential probe), voltage waveform across diode.

#### 4.5.4 Determining Efficiency

- Set the duty ratio to 50%.
- Adjust the load resistance so that load current is 0.25A.
- Measure the efficiency at switching frequencies of 40kHz, 60kHz, 80kHz, 100kHz.

### 4.6 Lab Report

The lab report should have a brief abstract detailing what has been done in the experiment. The remaining part of the report should consist of the information asked below along with any discussion you feel is necessary.



- Attach a graph of duty ratio versus output voltage (*CS5*) using the data obtained in section 4.5.1. Also plot the theoretically calculated results on the same graph. Compare the two plots. Comment about how the buck-boost converter works as a variable dc step-down or step-up transformer.
- Attach a copy of the inductor current (*CS5*) waveform obtained in section 4.5.2. Plot the experimental and theoretically estimated ripple current waveforms on the same graph. Compare the two graphs and comment.
- Plot the efficiency versus frequency using the data obtained in section 4.5.4. Comment on the results you obtain.
- Compare and comment on the efficiencies obtained in the buck, boost and buck-boost converters.

# Experiment 5

## Flyback Converter

### 5.1 Objective

The objective of this experiment is to study the characteristics of the flyback converter using the power-pole board in open loop control mode. Our main goal is to compare the theoretical results with the experimental results.

### 5.2 Preparing the Setup

Make the connections on the power-pole board as shown in Fig. 5.1 to use the lower MOSFET.

- Use the Flyback magnetics board. The turns ratio is 1:1
- Use a variable load resistor as a load.
- Connect the  $\pm 12V$  signal supply to the *DIN* connector. Signal supply switch S90 should be OFF.

### 5.3 Checks before Powering the Circuit

- Check the circuit connections as per the schematic.
- Check that the lower MOSFET has been selected.
- Have your circuit checked by your *Lab Instructor*

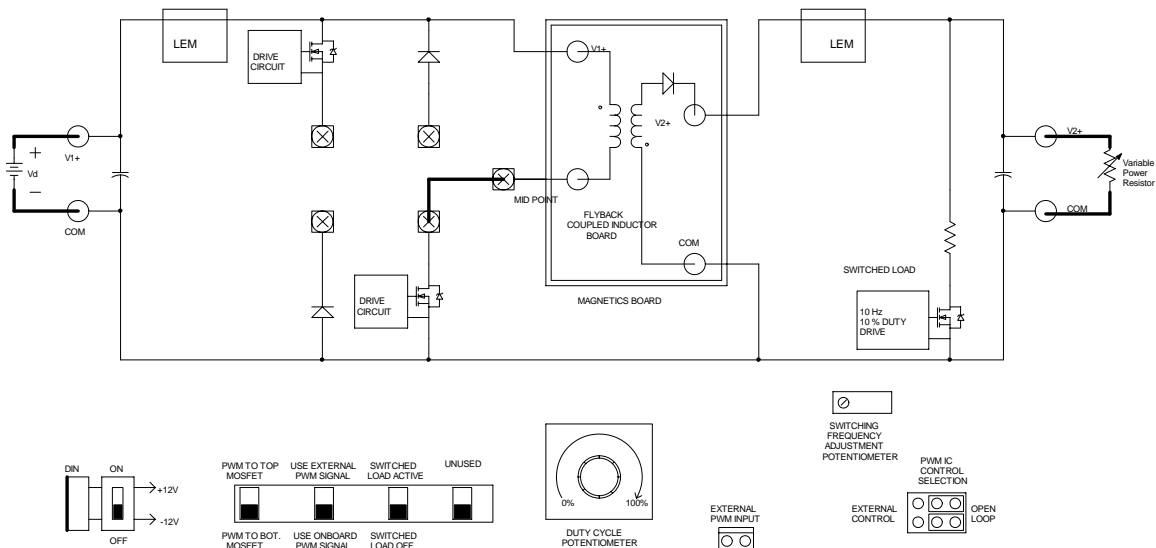

Figure 5.1: Schematic of Flyback Converter

## 5.4 Powering the Circuit

- Switch ON the signal supply. Check for green LED.
- Set the switching frequency to 100kHz and the duty ratio to 50%.
- Set  $R_L = 30\Omega$ .
- Apply input voltage  $V_d$  of 15V at terminal  $V1+$  and  $COM$ .

## 5.5 Measurements

Take the following measurement,

### 5.5.1 Varying Duty Ratio

- Vary the duty ratio from 0% to 60% (in steps of 10%).
- Measure the average output voltage ( $V2+$ ) for the corresponding values of duty ratios.
- Calculate the theoretical average output voltage value for the corresponding duty ratios.
- Compare the observed average output voltage results with the calculated ones.

### 5.5.2 Constant Duty Ratio

- Set the duty ratio to 50%, switching frequency to 100kHz.
- Using differential probe, observe and make a copy of the voltage across the primary side of the coupling inductor.
- Observe and make the copy of the voltage across the secondary side of the coupling inductor.
- Observe and make the copy of the input current ( $CS1$ ) and output current ( $CS5$ ).

### 5.5.3 Switched Load Active

- Set the duty ratio to 50%.
- Set the switching frequency to 100kHz.
- Switch ON the switched load to the active position, using the selector switch bank as shown in Fig.5.2.
- Observe and make a copy of the output voltage ( $V2+$ ) waveform. Adjust the time base to show the details of switching transients as the load is switched.

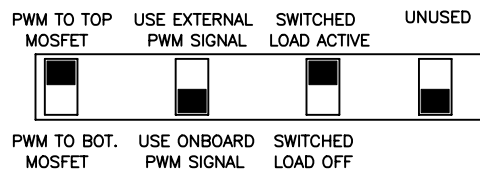

Figure 5.2: Switch Positions for Flyback Converter controller with switched load

### 5.5.4 Determining Efficiency

- Switch the switched load OFF.
- Keep the duty ratio constant at 50%.
- Adjust the load resistance so that load current is A.
- Measure the efficiency at the switching frequencies of 40kHz, 60kHz, 80kHz, 100kHz.

## 5.6 Lab Report

The lab report should have a brief abstract detailing what has been done in the experiment. The remaining part of the report should consist of the information asked below along with any discussion you feel is necessary.

- Attach a graph of duty ratio versus output voltage ( $V_{2+}$ ) using data obtained in section 5.5.1. Also plot the theoretically calculated results on the same graph. Compare the two plots and comment about how the flyback converter works as either a step-down or step-up transformer.
- Using the waveforms obtained in section 5.5.2, explain the relationship between the primary and secondary voltages of the coupled inductor.
- Using the current waveforms obtained in section 5.5.2, estimate the magnetizing current for the coupled inductor. Compare the output inductor current ( $i_{L5}$ ) waveforms with the output current waveform for the buck converter obtained in "BUCK CONVERTER EXPERIMENT". What's the effect of this current on the output voltage ripple.
- Using the waveforms obtained in section 5.5.3, comment on the output voltage variation due to the effect of the switched load. What could be done to overcome this problem ?
- Plot the efficiency versus frequency using the data obtained in section 5.5.4. Comment on the results you obtain.

# Experiment 6

## Forward Converter

### 6.1 Objective

The objective of this experiment is to study the characteristics of the forward converter. The forward converter will be operated in open loop mode (no feedback). Our main goal is to compare the theoretical results with the experimental results.

### 6.2 Preparing the Setup

Make the connections on the power-pole board as shown in Fig. 6.1 to use the lower MOSFET.

- Use the Forward magnetics board.
- Use a variable load resistor as a load.
- Connect the  $\pm 12V$  signal supply to the *DIN* connector. Signal supply switch S90 should be OFF.

### 6.3 Checks before powering the circuit

- Check the circuit connections as per Fig. 6.1
- Confirm that you have selected the lower MOSFET.
- Have your circuit checked by your *Lab Instructor*

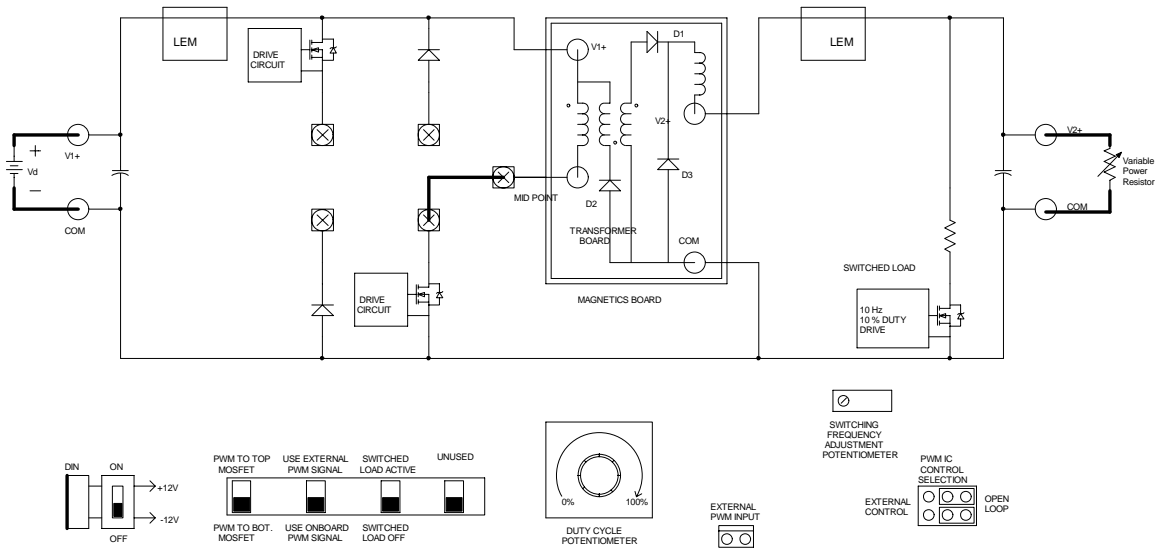

Figure 6.1: Schematic of Forward Converter

## 6.4 Power Circuit

- Switch ON the signal supply. Check for green LED.
- Set the switching to 100kHz.
- Set the duty ratio to its minimum.
- Set  $R_L = 10\Omega$ .
- Apply input voltage  $V_d$  of 15 V at the terminals  $V1+$  and  $COM$ .

## 6.5 Measurements

Take following measurements,

### 6.5.1 Varying Duty Ratio

- Vary duty ratio from minimum to 40% (in steps of 10%).
- Measure the average output voltage ( $V2+$ ) for the corresponding values of duty ratio.
- Calculate the theoretical average output voltage for the corresponding duty ratios.
- Compare the observed average output voltage results with the calculated ones.

### 6.5.2 Constant Duty Ratio

- Set the duty ratio to 40%, switching frequency to 100kHz,  $R_L = 10\Omega$
- Observe and make a copy of the primary side voltage of the transformer. Use a differential probe to measure the voltage. Store the waveforms.
- Observe and make a copy of the input current ( $CS1$ ), output current ( $CS5$ ) and MOSFET current ( $CS3$ ).

### 6.5.3 Switched Load Active

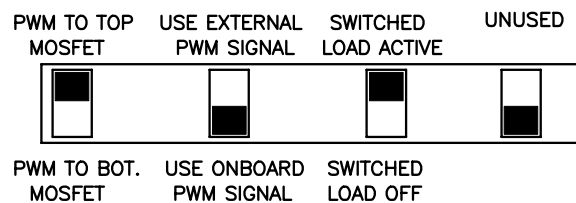

Figure 6.2: Switch Position for Forward Converter using Switched Load

- Set the duty ratio to 40%.
- Set the switching frequency to 100kHz.
- Switch ON the switched load to the active position using the selector switch bank as shown in Fig. 6.2.
- Observe and make a copy of the output voltage ( $V_{2+}$ ) waveform. Adjust the timebase to show the details of the switching transients as the load is switched.

### 6.5.4 Determining Efficiency

- Switch the switched load OFF.
- Set the duty ratio to 40%.
- Measure the efficiency at switching frequency say 40kHz, 60kHz, 80kHz, 100kHz.



## 6.6 Lab Report

The lab report should have a brief abstract detailing what has been done in the experiment. The remaining part of the report should consist of the information asked below along with any discussion you feel.

- Attach a graph of duty ratio versus output voltage ( $V_{2+}$ ) using data obtained in section 6.5.1. Also plot the theoretically estimated results on the same graph. Compare the two plots. Comment about how the converter works as a variable dc step-down transformer.
- Using the waveforms obtained in section 6.5.2, explain the detailed per switching cycle relationship between the waveforms. Explain why you have been asked to restrict the duty ratio to a maximum of 40%.
- Using the waveforms obtained in section 6.5.2, plot the primary and tertiary winding currents in transformer. What is the effect of the inductor on the magnetics board? Also explain the importance of having D3 on the magnetics board?
- Comment on the output voltage variation obtained in section 6.5.3 when there is a sudden load change.
- Plot the efficiency versus frequency using the data obtained in section 6.5.4. Comment on the results you obtain.

# Experiment 7

## Switching Characteristic of MOSFET and Diode

### 7.1 Objective

The objective of this experiment is to study the switching characteristics of power MOSFETs and power diodes using a buck converter. The circuit will be operated in open loop conditions (no feedback). Our main goal is to understand the switching behavior of these two power devices.

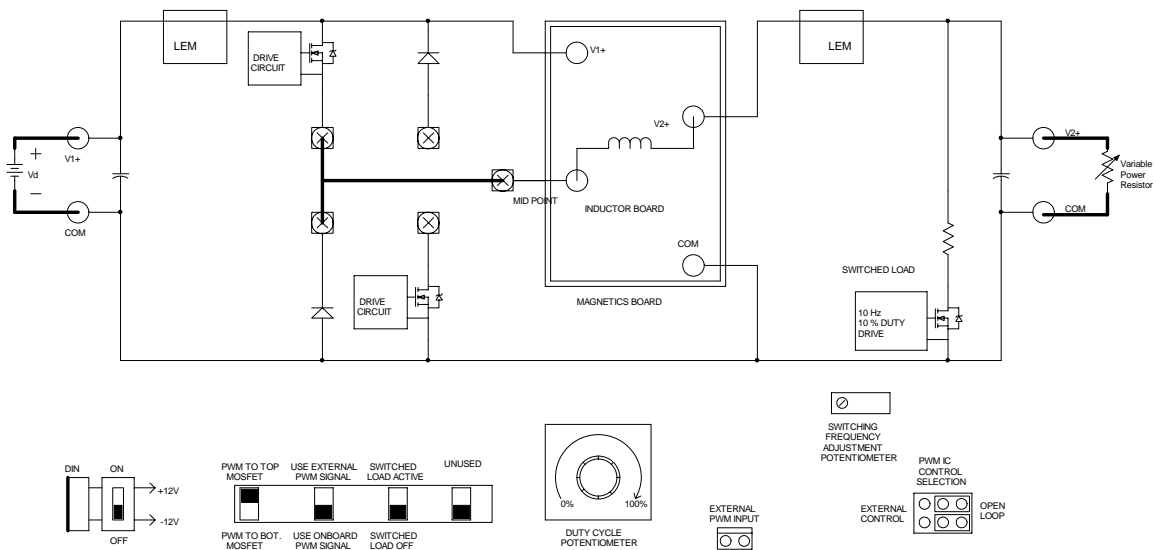

Figure 7.1: Schematic of Buck Converter

## 7.2 Preparing the Setup

Construct the buck converter circuit as shown in Fig. 7.1 to use the upper MOSFET and lower diode.

- Use the BB magnetics board board. The inductor is  $100\ \mu\text{H}$ .
- Use a variable load resistor as a load.
- Connect  $\pm 12\text{V}$  the signal supply to the *DIN* connector. Signal supply switch S90 should be OFF.

## 7.3 Checks Before Powering The Circuit

- Check the circuit connections as per the schematic.
- have your circuit checked by your *Lab Instructor*

## 7.4 Powering the Circuit

- Switch ON the signal supply. Check for green LED.
- Adjust the duty ratio to 50%.
- Set the switching frequency of 100kHz.
- Set  $R_L = 50\Omega$ .
- Apply input voltage  $V_d$  of 15 volts.

## 7.5 Measurement and Waveforms

1. Observe and make a copy of the Drain-Source voltage ( $V_{DS}$ ) using differential probe, PWM signal and Anode-Cathode voltage ( $V_{AK}$ ) of lower diode.
2. Observe and make a copy of the current through the upper MOSFET (between *CS2* and Source) using a differential probe, inductor current (between *CS5* and *COM*), lower diode current (between *CS3* and *COM*).
3. Observe and make a copy of the Anode-Cathode diode voltage  $V_{AK}$  and diode current. Adjust the time base to show the switching details during turn-ON and turn-OFF.

4. Observe and make a copy of the Drain-Source MOSFET voltage  $V_{DS}$  and MOSFET current. Adjust the time base to show the switching details during turn-ON and turn-OFF.

## 7.6 Lab Report

The lab report should have a brief abstract detailing what has been done in the experiment. The remaining part of the report should consist of the information asked below along with any discussion you feel necessary.

- Compare the switching waveform results obtained in step 1 of section 7.5 to the ideal voltage waveform.
- Compare the switching current waveforms obtained using step 2 of section 7.5 to the ideal current waveform.
- Using the waveforms obtained in step 3 of section 7.5, calculate the conduction and switching losses of the Diode.
- Using the waveforms obtained in step 4 of section 7.5, calculate the conduction and switching losses of the MOSFET.
- Using the values of conduction and switching losses of the MOSFET and Diode obtained in the above steps, estimate the efficiency of the converter. Compare the estimated efficiency with the efficiency obtained for the buck converter in the "Buck Converter Experiment". What could be the reasons for the difference in values, if any ?



# Experiment 8

## Voltage-Mode Control

### 8.1 Objective

The objective of this experiment, is to design a controller to operate the buck converter in voltage control mode. For this experiment, a plug-in daughter board will be used to accomplish the control objective. The small-signal transfer function  $\frac{v_o(s)}{d(s)}$  ( $d(s)$  is a small-signal perturbation in the duty cycle and  $v_o(s)$  is the corresponding variation in the output voltage) must first be obtained for the buck converter. The plug-in daughter board is used to implement the voltage-mode control feedback with the required open-loop gain.

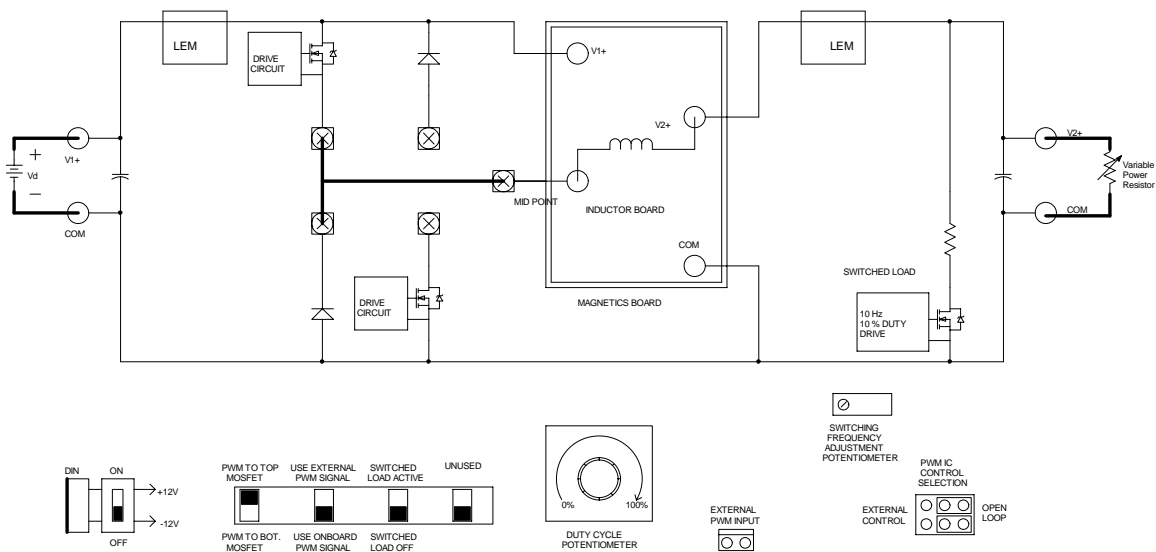

Figure 8.1: Buck Converter Using Power-pole board

## 8.2 Preparing the Setup and Open-Loop Mode

Construct the buck converter circuit as shown in Fig. 8.1 using the BB magnetics board.

- Connect and turn on the  $\pm 12v$  signal supply and check for green LED.
- Adjust the duty ratio to 50%.
- Adjust the switching frequency to 100kHz.
- Switch ON the switched load to active position using selector switch bank as shown in Fig. 8.2.
- Adjust the variable load resistance  $R_L$  to  $10\Omega$ .
- Have your circuit checked by your *Lab Instructor*.
- Apply DC supply voltage  $V_d$  to 24V.

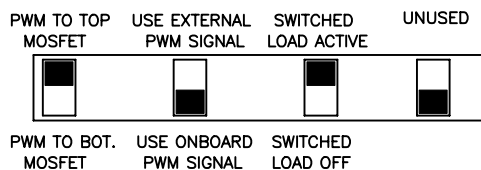

Figure 8.2: Selector Switch Position for Switched Load

## 8.3 Measurements in Open-Loop Operation

Observe and make a copy of the output voltage waveform ( $V_{2+}$ ). Adjust the timebase to show the details of the switching transients as the load is switched.

## 8.4 Preparing the Setup for finding $\frac{v_o(s)}{d(s)}$

- Turn OFF the supply voltage  $V_d$ , the signal supply and remove the jumper J64 (G-5 in Fig. 1.2)
- Switch the switched load OFF as shown in Fig. 8.1.
- Connect the function generator output to J64 (please confirm the polarity of connector).
- Adjust the function generator voltage  $v_i$  to 200mV peak-peak and 50Hz sinusoidal output.

- Keep the variable power resistor at  $10\Omega$  and duty ratio at 50%.
- Have your circuit checked by your *Lab Instructor*.
- Turn ON the  $\pm 12V$  signal supply and check for green LED.
- Apply  $V_d=24V$ .

## 8.5 Finding Transfer Function $\frac{v_o(s)}{d(s)}$

- Set the scope to AC coupling to measure the output voltage  $V2+$  AC ripple.
- Measure the magnitude ratio of  $V2+$  and  $v_i$  and phase difference between them.
- Repeat the above procedure for different frequencies of  $v_i$  from 50Hz to 10kHz.

## 8.6 Type 3 Voltage Controller

Once you get the transfer function or the Bode-plot of the buck converter, you can design a Type-3 voltage controller. The Type-3 voltage control board has the schematic as shown in Fig. 8.3.

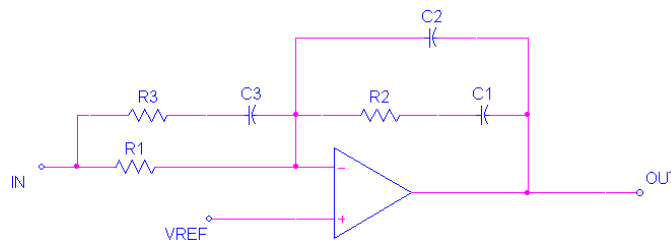

Figure 8.3: Voltage Controller Plug-in Board

The values of the resistors and capacitors of the voltage control board are given in Table. 8.1

- Reference value  $V_{REF}$  can be set using the duty ratio pot.
- Reference value  $V_{REF}$  can't be set below 10V.
- For the pin details of terminal strip J60, please refer the schematic of the power-pole board.



Component	Component Value
R1	$100k\Omega$
R2	$20.66k\Omega$
R3	$10.31k\Omega$
C1	$25.19nF$
C2	$2.5976nF$
C3	$4.7191nF$

Table 8.1: Voltage Control Board Component Values

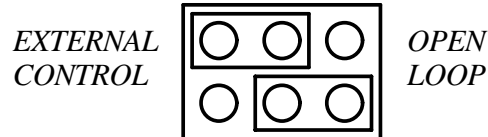

Figure 8.4: Control selection for Voltage-Mode Control plug-in board

## 8.7 Preparing the Setup for Voltage-Mode Control Operation

- Set the control selection jumpers J2 and J3 (J-5 in Fig. 1.2) as shown in Fig. 8.4.
- Remove the function generator and insert the jumper J64.
- Insert the Voltage-Mode Control plug-in board in the terminal strip 60.
- Keep  $R_L = 10\Omega$ .
- Switch ON the switched load to the active position using the selector switch bank as shown in Fig. 8.2.
- Turn ON  $\pm 12V$  signal supply and check for green LED.
- Have your circuit checked by your *Lab Instructor*.
- Set  $V_d$  to 24V.
- Use the duty cycle pot RV64 to set  $V_{2+}$  to 12V.

## 8.8 Measurements in Voltage-Mode Control Operation

Observe and make a copy of the output voltage  $V_{2+}$ .

## 8.9 Lab Report

The lab report should have a brief abstract detailing what has been done in the experiment. The remaining part of the report should consist of the information asked below along with any discussion you feel is necessary.

- Construct the bode plot of the small-signal transfer function  $\frac{v_o(s)}{d(s)}$  of the converter from the results obtained in section 8.5
- Use the K-factor method described in chapter 4 of a “First Course on Power Electronics and Drives” to design a type 3 voltage mode controller for the buck converter.  $L = 100\mu H$ ,  $C = 690\mu F$ ,  $r = 0.1\Omega$ ,  $f_s = 100kHz$ ,  $V_d = 42V$  and the duty ratio is set to 50%. The phase margin of the open-loop transfer function should  $60^\circ$  at 1kHz.

(Note that these are the same specifications for the voltage-mode control you used in section 8.7).



# Experiment 9

## Peak Current Mode Control

### 9.1 Objective

In this experiment, we will be using a plug-in board to accomplish peak current mode control for a buck-boost converter. First the aspects of constant frequency peak current mode control will be explored. Then the plugin board will be used to achieve feedback voltage control of the converter. The goal is to understand how to design a peak current mode controller with voltage feedback.

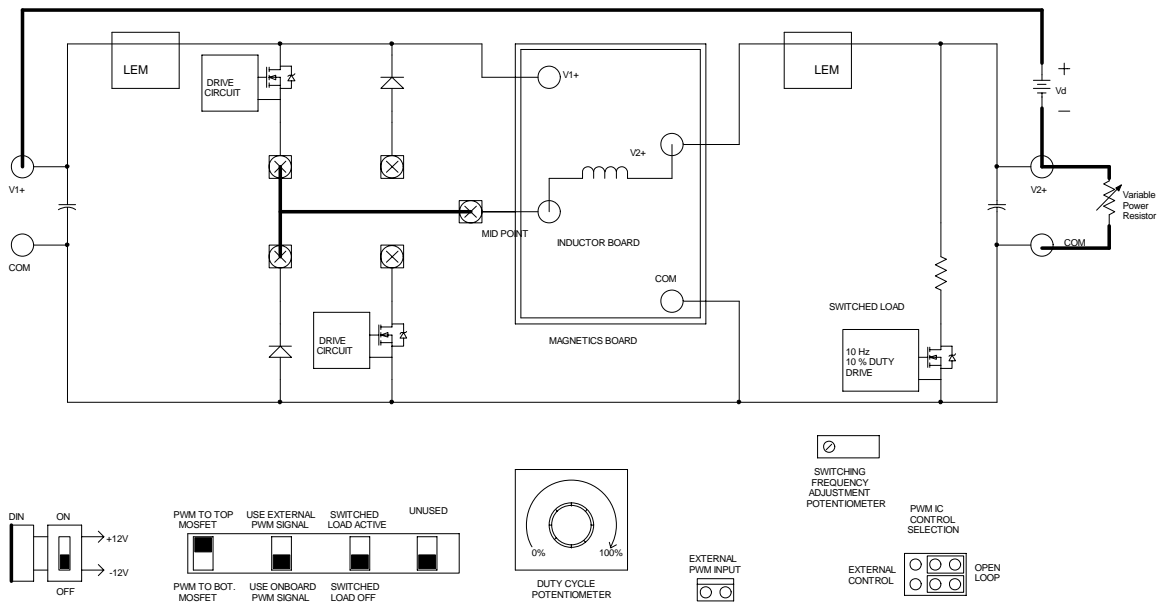

Figure 9.1: Current Mode Controller Schematic

## 9.2 Preparing setup for Open Loop Operation

- Reconstruct the buck-boost converter used in Expt. 3 as in Fig. 9.1.
- Turn on the signal power supply and set the switching frequency to 100 kHz and duty cycle such that output voltage  $V_o = 12$  V.
- Change the switch positions of the switch bank as shown in Fig. 9.2.
- Set  $V_d$  to 20 V and the variable power resistor to  $20 \Omega$ .

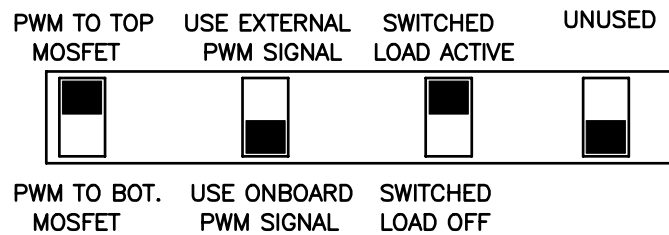

Figure 9.2: Switch Position for Switched Load

### 9.2.1 Measurements

- Observe the output voltage  $V_{2+}$  and inductor current on the oscilloscope.
- Store the waveform.

## 9.3 Preparing setup for closed loop operation and measurements

### 9.3.1 Closed Loop Operation Without Slope Compensation

- Setup the control selection as in Fig. 9.3.

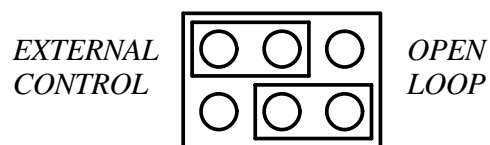

Figure 9.3: Switch Position for Closed Loop Operation

- Remove shorting link from J61 and insert the Type 2 Controller plug-in board whose circuit is shown in Fig. 9.4 into the terminal strip J60 (The pin numbers shown in the figure correspond to pin numbers on the terminal strip). This board will add the voltage feedback to the control.

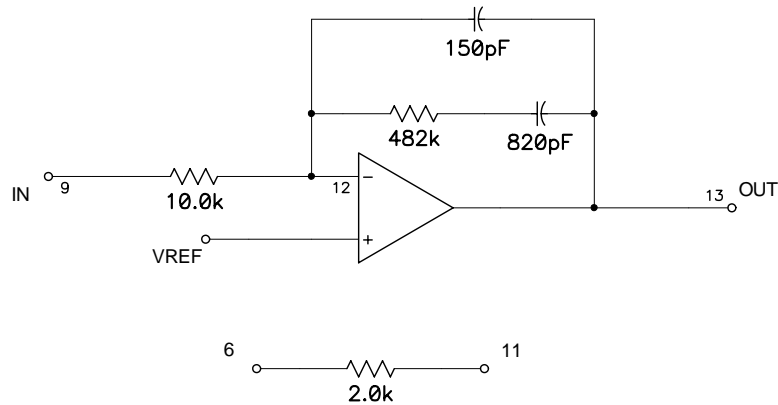

Figure 9.4: Type 2 Controller

- Set the duty cycle pot to minimum.
- Switch ON the main power supply and set it to 25 V.
- Change the switch positions of the switch bank as shown in Fig. 9.1.
- Switch ON the signal power supply. Ensure that main power supply is ON before signal power supply is switched ON.
- Observe the PWM and the inductor current waveforms.
- Slowly increase the reference voltage by turning the duty cycle pot clockwise. Observe the point where the inductor current starts displaying oscillatory behavior. Record the corresponding duty cycle from the scope.
- Plug in the slope compensation jumper on to J61. The slope compensation jumper circuit is shown in Fig. 9.5. Observe how the inclusion of slope compensation affects the stability of the converter.

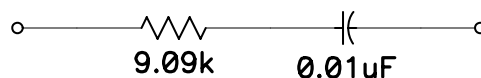

Figure 9.5: Slope Compensation Jumper

### 9.3.2 Closed Loop Operation With Slope Compensation

- Ensure that the plug-in board and the slope compensation jumper are plugged in.
- Set the duty cycle pot to minimum.
- Switch ON the main power supply and set it to 15 V.
- Switch ON the signal power supply.
- Observe the PWM and the inductor current waveforms.
- Slowly increase the reference voltage by turning the duty cycle pot clockwise. Observe the point where the inductor current starts displaying oscillatory behavior. Record the corresponding duty cycle from the scope.

### 9.3.3 Dynamic Performance of Closed Loop System

- Ensure that the plug-in board and the slope compensation jumper are plugged in.
- Set the duty cycle pot to minimum.
- Switch on the main power supply and set it to 20 V.
- Switch on the signal power supply.
- Slowly increase the reference voltage to 12 V by turning the duty cycle pot clockwise.
- Observe the output voltage  $V_{2+}$  and the inductor current on the oscilloscope. Store the waveform.

## 9.4 Lab Report

The lab report should have a brief abstract detailing what has been done in the experiment. The remaining part of the report should consist of the information asked below along with any discussion you feel is necessary.

- Plot the output voltage  $V_o$  and inductor current  $i_L$  obtained in step 9.2.
- What is the maximum duty ratio stable operation of the converter in step 9.3.1? Plot the inductor current waveform for stable and unstable operation.
- What is the maximum duty ratio stable operation of the converter in step 9.3.2? Plot the inductor current waveform for stable and unstable operation.

- Explain how slope compensation affects the range of duty cycle obtainable in constant frequency peak current mode control.
- Explain why in step 9.3.1, it is important to switch on the signal power supply after turning on the main power supply.
- Plot the output voltage  $V_o$  waveforms and inductor current in closed loop operations with output voltage feedback (step 9.3.3).
- Comment on the effect of peak current controller on the operation of converter.



## APPENDIX

The detailed circuit of the the power-pole is attached. It consists of two sheets.

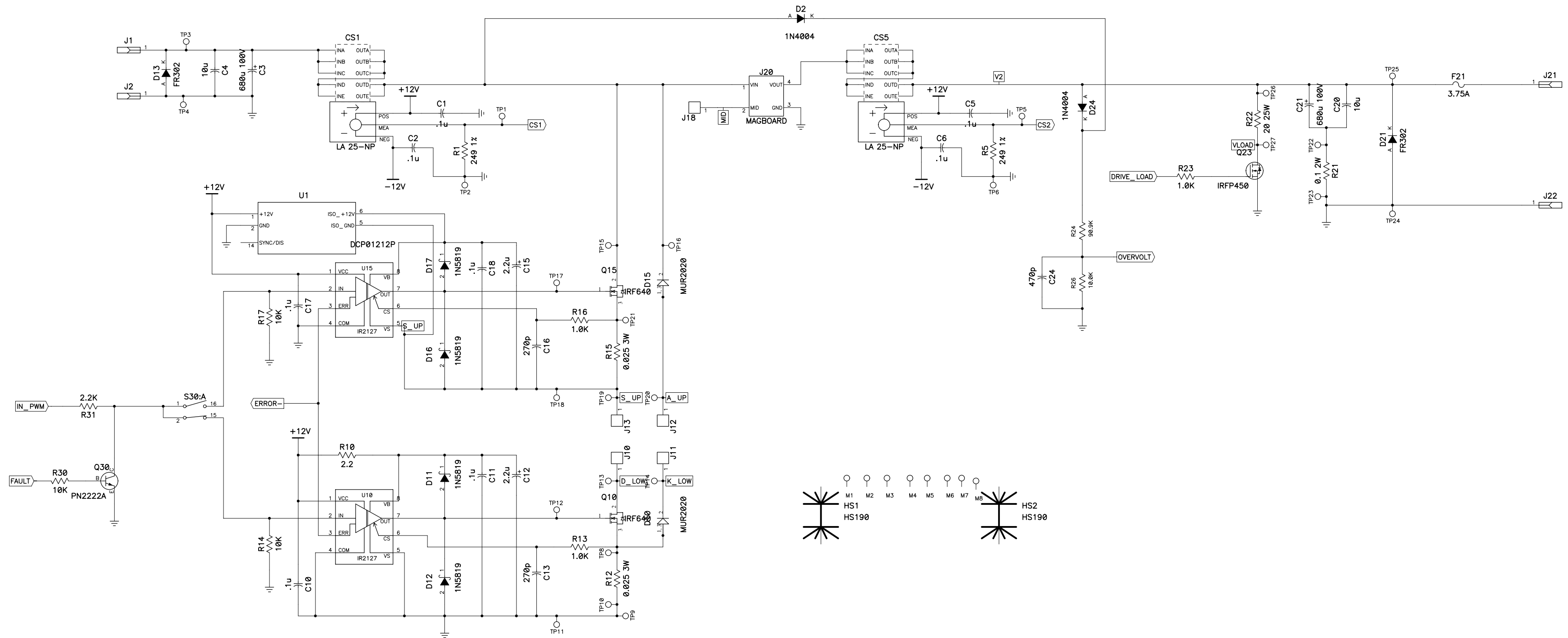

Title			Power Pole Board		
Size	Number				Rev
D					2
Date	07-02-2002		Drawn by		
Filename	PPIlab_rev2.SCH		Sheet 1 of 2		

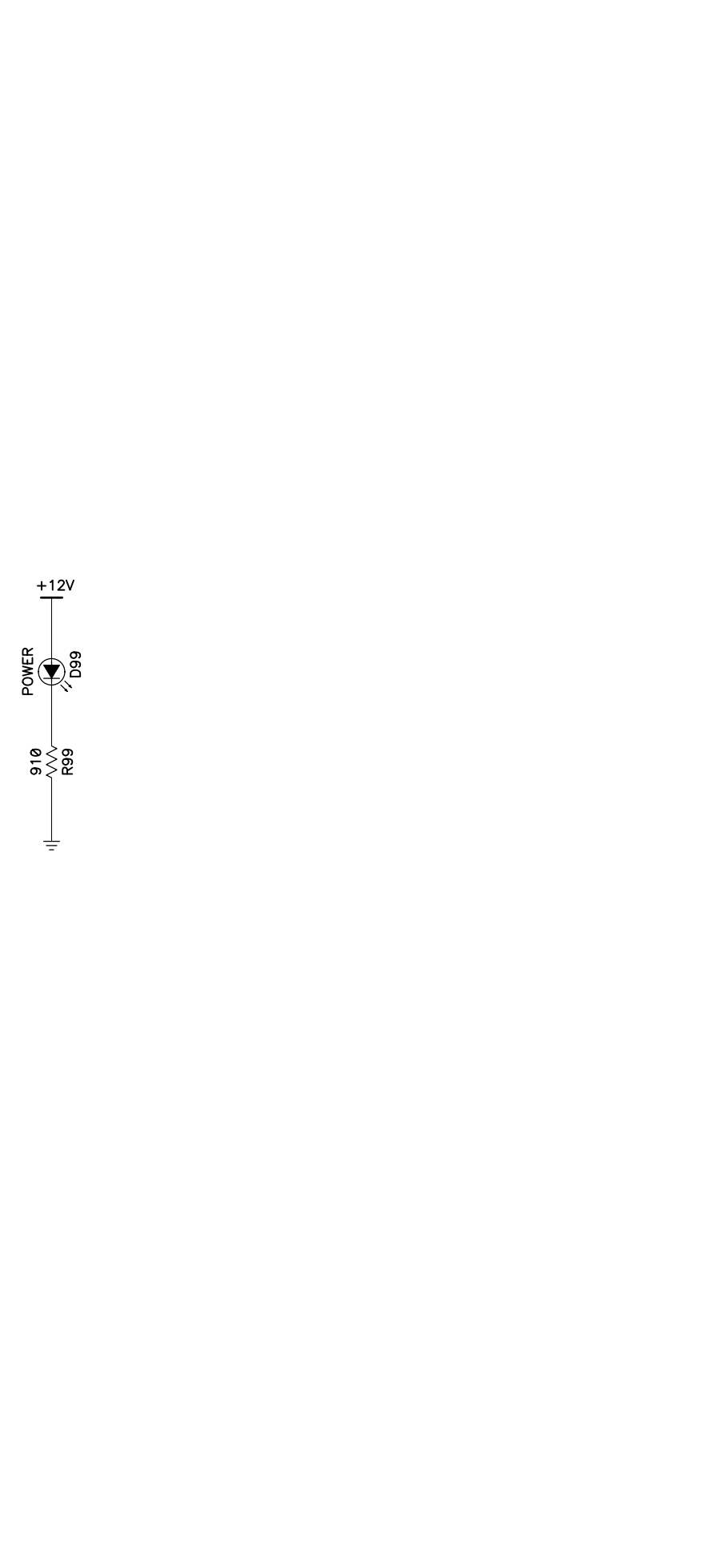
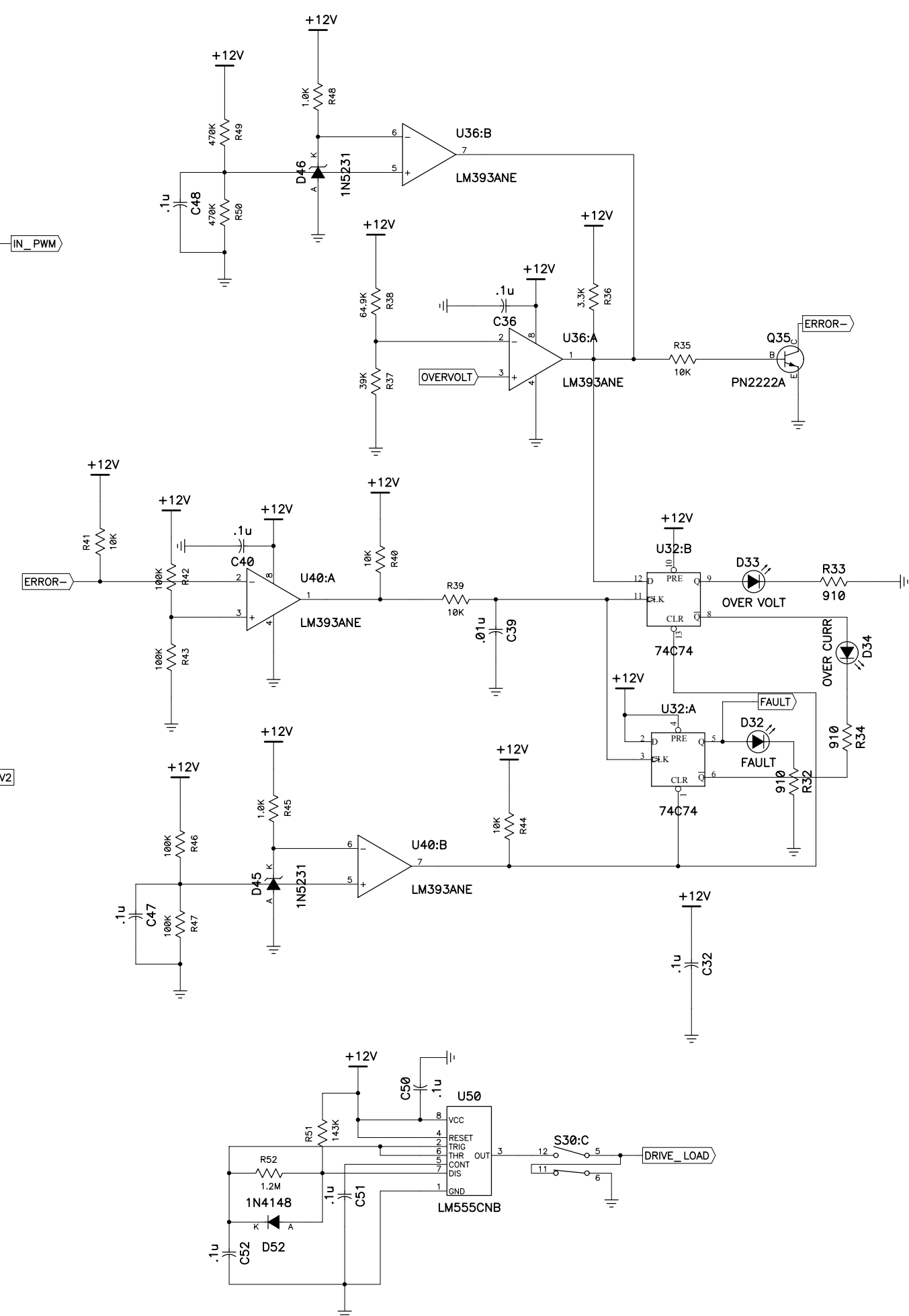
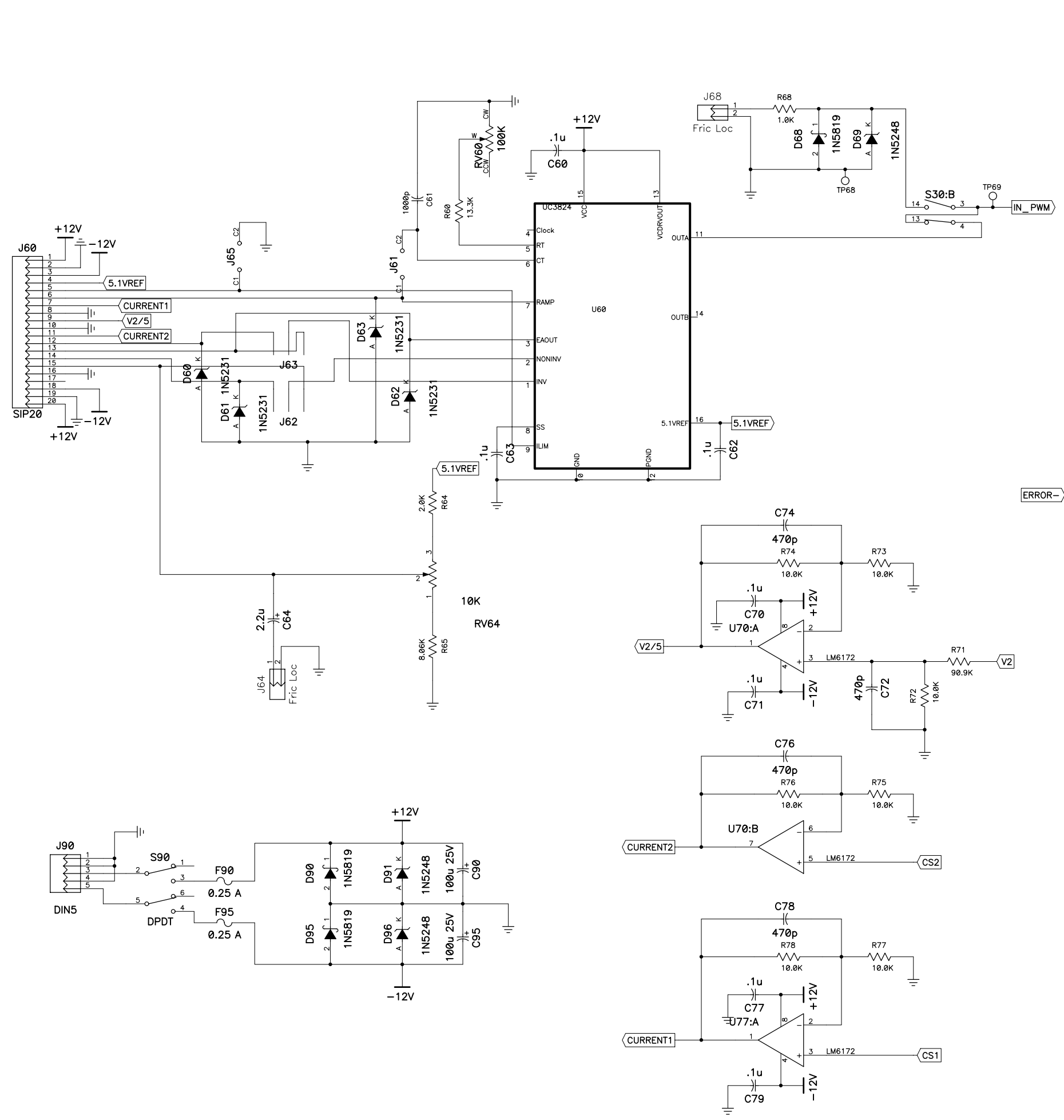

Title			Power Pole Board		
Size	Number				Rev
D					2
Date	07-02-2002		Drawn by		
Filename	PPIlab_rev2.SCH		Sheet		2 of 2