



copperhead 

OWNERS MANUAL

continuum 
AUDIBLE SCIENCE

TABLE OF CONTENTS

IMPORTANT INFORMATION AND NOTES.....	5
WHO SHOULD READ THIS MANUAL	5
HOW TO READ THIS MANUAL	5
STANDARD SYMBOLS AND SAFETY NOTIFICATIONS	5
SAFETY PRECAUTIONS	6
PACKAGING	7
COPPERHEAD TONEARM.....	8
SPECIFICATIONS	9
FEATURES.....	10
THE ARM WAND	10
THE HEADSHELL.....	10
AZIMUTH STABILIZED BEARING SYSTEM	10
ADJUSTABLE AZIMUTH.....	10
ADJUSTABLE VTA.....	10
LOW MASS PIVOT DESIGN.....	10
ULTRA RIGID CENTRAL TOWER.....	10
PRECISION GRADUATED RADIAL VTA VERNIER GAUGE.....	11
LARGE SCALE CARTRIDGE WEIGHT ADJUSTMENT.....	11
SMALL SCALE CARTRIDGE WEIGHT ADJUSTMENT.....	11
THE FINGERLIFT.....	11
THE HYDRAULIC ARM LIFTER.....	11
THE COUNTERWEIGHT.....	11
THE VERTICAL BEARING MOTION.....	12
HORIZONTAL MOTION SUPPORT.....	12
VERTICAL TRACKING ANGLE (VTA) AND STYLUS RACK ANGLE (SRA)	12
OVERHANG ADJUSTMENT.....	14
ANTI SKATE ADJUSTMENT	14
INSTALLATION & SETUP	15
WHY CARTRIDGE SETUP AND ALIGNMENT IS CRITICAL.....	15
INSTALLATION	17
COPPERHEAD COMPONENTS.....	18
DISASSEMBLY FOR MOUNTING PROCEDURE	20
TONEARM PIVOT TO RECORD SPINDLE DISTANCE.....	21
MOUNTING THE MAIN ARM BASE TO THE ARMBOARD	22
MOUNTING THE MAIN ARM TOWER TO THE MAIN ARM BASE	23
VTA (SRA) SETUP HOW TO ADJUST VTA (SRA).....	24
COPPERHEAD ARMWAND LAYOUT	25
MAIN WAND ASSEMBLY - UNDERSIDE	25
MAIN WAND ASSEMBLY – TOP SIDE	26
HOW TO MOUNT THE ARMWAND	27
SKEWING THE REAR MAIN “HEART” SHAPED COUNTERWEIGHT	29
BALANCING THE ARMWAND.....	30
CARTRIDGE WEIGHT & BALANCE TABLE.....	32
COPPERHEAD COUNTERWEIGHT “WASHER” KIT	33
EXAMPLE: BALANCING A 15 GRAM CARTRIDGE.....	33
INSTALLING CARTRIDGE ON WAND.....	35
OVERHANG FINE ADJUSTMENT AND VTF CHECK.....	36
HOW TO CONNECT AND ADJUST THE ANTISKATE	37
GROOMING THE TONEARM WIRE.....	39
HOW TO ADJUST THE AZIMUTH	40
AZIMUTH ADJUSTMENT M3 SET SCREW.....	41
ADJUSTING ARMLIFTER HEIGHT.....	42
ADJUSTING ARMLIFTER ROTATION.....	43
INSTALLING OR REMOVING ARMLIFTER.....	44

SECURING THE ARM WIRE CABLE CLAMP OR TERMINATION BLOCK 45

OPERATION OF THE ARM **46**

OWNER CARE & MAINTENANCE **46**

CARING FOR METAL SURFACES..... 46

CLEANING THE TONEARM 46

BEARING MAINTENANCE..... 46

 COPPERHEAD’S DESIGN HISTORY 47

COPPERHEAD’S DESIGN TEAM **48**

Welcome and congratulations on your purchase of our Copperhead Tonearm. Your Copperhead was hand-crafted and assembled by the team at Continuum Audio Labs, and has been rigorously tested and is ready for your enjoyment.

The Copperhead is a new design in tonearm technology which has been developed by a team of dedicated music lovers with qualifications in advanced engineering and design, assisted by some of the most advanced computer aided design software in the market today.

We ask that you take the time to read this manual carefully to ensure that you not only enjoy optimum sound quality from your Copperhead, but also understand the care and maintenance procedures required to keep your Copperhead in as-new condition for many years to come.

If you have any questions in reference to any part of your Copperhead at any time in the future, please feel free to contact your nearest Continuum Consultant for assistance. Congratulations on choosing the Copperhead tonearm.

Your Authorised Continuum Consultant is:

Serial Number:

Date of Manufacture:

IMPORTANT INFORMATION AND NOTES

ENGLISH

WE RECOMMEND YOU READ THIS DOCUMENT IN ITS ENTIRETY BEFORE ATTEMPTING TO ASSEMBLE OR DISASSEMBLE YOUR NEW TONEARM.

NOTE: Improvements may result in specification or feature changes without notice. Illustrations may differ slightly for production models.

WHO SHOULD READ THIS MANUAL

This manual is designed for the installer and owner operator of the Copperhead tonearm.

HOW TO READ THIS MANUAL

The User manual (this manual) contains important notes that need to be observed to operate the Copperhead safely and correctly.

Before using the Copperhead, please read and thoroughly understand the contents of this manual. Keep this manual in a safe location.

Throughout this manual there will be standard symbols denoting important information.

If you have any questions in reference to any part of your Copperhead at any time in the future, please feel free to contact us or your Consultant for assistance.

STANDARD SYMBOLS AND SAFETY NOTIFICATIONS

For your safety and that of others, follow the guidelines provided on the following pages concerning the use of the product.

Symbols are used throughout this manual. These are provided to emphasize important points for your safety and that of others. The following are the symbols and their meanings:

CAUTION

Ignoring the instructions under this symbol when using the Copperhead may lead to damage to the device or hardware options.

SAFETY PRECAUTIONS

Category	CAUTION
Installation	<p>Do not dismantle or modify this device in any other way than described in this manual.</p> <p>Do not place anything on top of this device. Doing so may cause a malfunction.</p> <p>Do not install this device in direct sunlight, near a heater, or in a humid or dusty environment. Do not expose this unit to rain or moisture. Do not use or allow any liquid cleaning solutions to enter the unit.</p> <p>The components in the Copperhead are made to close tolerances with sliding fits on most bearing surfaces. Never over-tighten any of the provided fasteners. If you are in doubt request the assistance of a trained dealer representative to ensure no forcing or misalignment of the components during assembly.</p> <p>Before connecting to phono stage components, be sure to follow component manufacturer's instructions.</p> <hr/> <p>Clean tonearm, and controls with a soft cloth slightly moistened with a mild detergent solution. Do not use any type of abrasive pad, scouring powder or solvent such as alcohol or benzene.</p>

PACKAGING

Please retain all the packaging in a safe dry place away from fire hazard and/or pests which could damage the packaging materials. We highly recommend you retain the packaging your Copperhead came in, so that if at any point in the future you need to move your Copperhead, it can be done safely.

Never transport the tonearm assembled as this will potentially lead to serious damage to the bearing.

THERE ARE 5 MAIN COMPONENTS WHICH COMPRISE THE COPPERHEAD TONEARM SYSTEM

- 1 – Wand Assembly
- 2 – Tonearm Base, Bearing and Anti-Skate
- 3 – Wiring Harness
- 4 – Cartridge Screws
- 5 – Counterweight Washer Kit & Screws

COPPERHEAD TONEARM

The Copperhead Tonearm is named after a rare highly venomous Australian snake found in the higher reaches of the Victorian Alps. Altitude is no bar to the Copperhead.

Derived with the same ultra advanced software and technology Continuum Audio Laboratories pioneered to design and build the Cobra tonearm (Winner of Stereophile Analog Product of the Year 2006 award and Product of the Year Award 2006) the Copperhead is another groundbreaking product destined to become a favourite with discerning audiophiles.

The Copperhead design is very musical but remains uncoloured by spurious resonances. Continuum Audio Laboratories are the leader in using advanced software to develop a close correlation between the modelled behaviour of an arm and the actual real world performance. This allows our engineers to derive new solutions to previously unsolved problems.

Our engineers again applied the complete suite of advanced software available to Continuum Audio Laboratories towards the modelling of the Copperhead arm. Beginning with Finite Element Analysis using NASTRAN, PATRAN, and DYTRAN from www.mssoftware.com finalizing in the complex process of Gradient Shape Optimisation using Reshape™ from www.advea.com.

The final Copperhead shape emerged from this process as a refined sleek shape which maintained the “signature” free sound of the Cobra design. The wand is eggshell thin with special contours and compound curves to “shape” the resonant behaviour of the arm. These behaviours are only visible with specialized software tools but clearly audible to experienced listeners. Designing with these tools allows us to bring arm design into the 21st century.

This breakthrough in arm engineering ensures the shape of the wand improves the sound of the arm beyond that which is possible using conventional tube designs.

No other competitively priced arm comes close to the sonic reality of the Copperhead.

SPECIFICATIONS

- **Effective Length:** *(from stylus to pivot point)* 239mm
- **Overhang:** *(from Stylus to spindle Centre)* 17.3mm
- **Offset:** *(Headshell Offset in degrees)* 23 Degrees
- **Cartridge Fixing Centres:** 12.7mm for standard M2.5 socket head cap screws
- **Mounting Distance:** *(from pivot to spindle centre)* 221.7mm
- **Arm Mount Hole Pitch:** 76mm by 4 equidistant cardinal points for 4mm metric socket head cap screws.
- **Depth Below mounting surface:** 40-50mm.
- **Radial Clearance for Counterweight:** 90mm
- **Clearance from plinth surface to top of arm mount:** 150mm preferred for arm wire training.
- **Cartridge Weight Range:** 0-20Grams – Adjusted by Mass Addition/Subtraction of Supplied Weight Adjustment Kit. Fine tuned by 8 Gram sliding set screw for 0.001 Gram adjustment increments.
- **VTA Adjust:** – Yes
- **Azimuth Adjust:** - Yes
- **Horizontal Natural Frequency:** 7-10Hz depending on suitable cartridge
- **Vertical Natural Frequency:** 7-10Hz depending on suitable cartridge
- **NULL POINTS:** 66.0mm Inner 120.8mm Outer
- **Audio Lead:** Supplied with Continuum Audio Labs "six-nines" Copper as 1.5 meter standard in our preferred configuration of single RCA Termination from Cartridge Clip to RCA Male Connector.
Other Arm leads are available and can be supplied on request.
Other arm wires on request.
- **DIN Plugs:** can be fitted as an optional extra.
- **Complete Arm Weight:** 0.5Kg Nominal

FEATURES

The Copperhead represents a major breakthrough in tonearm technology. By the use of advanced software design tools which, for the first time, allowed us to simulate the real-time dynamics of a tonearm in play; we could visualize the flexural and vibrational issues inherent in all tonearms. This allowed us to create the unique Copperhead shape which overcomes these limitations.

THE ARM WAND

Reshape™ Shape Optimised, Resonance Tuned Compound Curve Wand from proprietary woven fibre technology pioneered by Continuum Audio Laboratories. Wands are interchangeable allowing you to easily interchange arm wands for quick cartridge changeovers (i.e Stereo to Mono).

The Copperhead is unique monocoque construction using advanced fibre and resin technology proprietary to Continuum Audio Labs. The shape of the arm wand is optimised to reduce the resonances inherent in conventional tonearm mechanisms. The Copperhead's polymer/fibre technology is extremely well damped and overcomes the limitations found in other materials used in tonearm manufacturer.

THE HEADSHELL

The Copperhead headshell is an integrated part of the arm wand and has standard slots for M2.5 cartridge screws. The use of compound curves make the head of the arm very resistant to torsional vibration modes created by the stylus groove interaction.

AZIMUTH STABILIZED BEARING SYSTEM

The Sapphire Ring Swash plate rides on damped ABEC9 miniature precision bearings to stabilize the arm azimuth. (Also found in the Copperhead tonearm system)

Primary Radial and Vertical Pivot is on a primary Sapphire Vee Jewel bearing with hardened stainless pivot.

ADJUSTABLE AZIMUTH

Azimuth is adjustable by means of set screw located adjacent to main pivot.

ADJUSTABLE VTA

Copperhead uses a 25mm central tower with a 40TPI (threads per inch) Microscope Thread for ultra fine VTA adjustment. Every 4mm of vertical adjustment at the rear of the tonearm will equal 1 degree of change at the stylus tip. Even micro adjustments of 1 arc minute at the rear of the arm will be audible to experienced audiophiles.

LOW MASS PIVOT DESIGN.

No additional mass is placed over the pivot to improve the responsiveness of the bearing system. The Copperhead is free of the inertial energy storage found in high mass bearing systems.

ULTRA RIGID CENTRAL TOWER

Located in a precision machined mounting collar with integrated locking collar, this locking collar spreads the clamping load on the adjustable VTA shaft and prevents movement when locked. No point loads.

PRECISION GRADUATED RADIAL VTA VERNIER GAUGE

Allows for repeat VTA setting accurate to 1 arc minute (360 degree graduation). 4 mm adjustment at rear pivot equals 1 degree of Stylus Rake Angle adjustment. A complimentary VTA Vertical Scale Vernier allows for broad range calibration.

LARGE SCALE CARTRIDGE WEIGHT ADJUSTMENT

By a simple addition/subtraction method with supplied washer kit this maintains the designed optimum effective mass relationship with a broad range of cartridges.

SMALL SCALE CARTRIDGE WEIGHT ADJUSTMENT

By a precision set screw at the rear of the arm the ultra fine adjustment allows for +- 0.5 Grams in 0.001gram increments

THE FINGERLIFT

The Copperhead finger lift is extended to the right of the head shell at an angle designed to allow safe cueing.

It is recommended that one use extreme caution when cueing manually as stylus damage can result from minor errors in handling. We recommend use of the hydraulic arm lifter to ensure safe operation of cartridge cueing.

THE HYDRAULIC ARM LIFTER

The hydraulic arm lift is an standard industry format using silicon gel damping. The height of the hydraulic arm lifter is adjustable using a standard metric allen wrench.

THE COUNTERWEIGHT

The Copperhead uses a unique counter-weight design that ensures the tracking force remains constant regardless of VTA adjustment.

The neutral balance has been achieved by locating the arm pivot system at the level of the record and locating the centre of mass at the height of the record.

In addition, to minimize warp wow (pitch changes as the stylus rides up and down over record warps), the arm's vertical pivot should be at the same height as the record surface. The Copperhead uses a shape optimized counterweight for reduction of reflected vibration.

THE VERTICAL BEARING MOTION

The Primary Pivot is a precision sapphire vee jewel with hardened steel matching central pivot. Used in the finest of aircraft instruments this pivot technology does not require heavy mass to be positioned over the pivot, thus allowing for exceptional tracking and response to groove modulation.

Secondary Pivot provides horizontal stabilisation and azimuth alignment with a hardened steel inverted pivot resting on a man made sapphire “Swash Plate”.

This secondary pivot plays a crucial role in the stability of the arm allowing for optimum placement of the counterweight thus removing inertial problems associated with alternative stabiliser designs.

HORIZONTAL MOTION SUPPORT

The Copperhead uses two precision matched ABEC 7 vertically opposed bearings with internal damping are used to minimise resistance in the circular motion for the secondary pivot.

VERTICAL TRACKING ANGLE (VTA) AND STYLUS RACK ANGLE (SRA)

Continuum Audio Labs recognizes that the original cutting lathes used to make the master recordings have different orientation of the cutter to the surface of the original lacquer. Therefore, during playback even minor changes in SRA or VTA can have significant audible effects.

The Copperhead offers the discerning audiophile an easy to adjust mechanism to extract the last vestiges of performance from your favourite LP. To adjust the VTA, two screws located on the base of the main arm mount are gently loosened to free the main arm tower

The user turns the VTA fine vertical adjustment knob clockwise to raise the arm pivot and counter-clockwise to lower the arm pivot.

Once the desired setting is reached the screws are gently tightened to lock the arm mechanism precisely in place. This system prevents any grub screw marking of the main sliding shaft system. This is adjustable during playback to dial-in your favourite setting for various thickness of LP's.

A broad scale vertical Vernier indicator is located on the rear of the main arm support tower which is further enhanced by a fine scale micrometer dial on the adjustment knob located at the top of the main arm support tower.

A vertical movement of 4mm in the main arm pivot represents 1 degree of VTA (SRA) change. The Copperhead arm is very revealing of setup errors so will require the best possible alignment in the horizontal and vertical plane.

It is advisable to follow the cartridge manufacturer's recommendations to ensure the top of the cartridge mounting surface is parallel to the surface of the record.

The Copperhead arm requires a dedicated tool to set the cartridge mounting surface parallel to the record surface.

As a general rule if the VTA is too high the sound will be “lean and thin”, and if the VTA is too low the sound will be more bass heavy and exhibit less transparency. This is of course totally to user preference.

OVERHANG ADJUSTMENT

The nominal effective length (stylus tip to main arm pivot) is 239mm. The length of slots in the headshell allows +/- 6mm from nominal effective length. This allows the majority of cartridges to be properly mounted.

For the above effective length, the overhang based on Baerwald alignment should be 17.3mm and 17.8mm for Lofgrin. The main arm pivot to platter spindle distance should be 221.7mm.

ANTI SKATE ADJUSTMENT

The Copperhead is equipped with an anti-skate device which provides optimal anti-skate force for most records.

It is geometrically designed to increase the anti-skate force, as a percentage of the tracking force (from 8% of the tracking force at the start of the record to 12% of the tracking force at the end of the record).

The Arm wire guide is designed to minimise torque forces emanating from the arm wires affecting the horizontal motion of the arm.

We recommend a quality tool such as "Wally Skater" from WAM Engineering, available from reputable LP suppliers, is used to set anti-skate parameters.

CAUTION: In our opinion use of a grooveless vinyl surface to determine anti-skate adjustment is an inaccurate method.

INSTALLATION & SETUP

WHY CARTRIDGE SETUP AND ALIGNMENT IS CRITICAL

If a phono cartridge is not correctly setup, damage can occur to your precious record collection, and you will not experience the incredible realism that a good analogue system can reproduce.

The design of the Copperhead tonearm allows for minute adjustments to be made to ensure the stylus tip is correctly positioned in all planes.

The stylus tip traces the musical signal inscribed in the record groove, which can contain modulations as small as a millionth of an inch. Therefore, small adjustments to the stylus tip's position will alter the sound significantly.

Good tonearm designs allow for precision adjustment in 4 main areas.

1. Tracking Angle
2. Azimuth Angle
3. Vertical tracking Angle (VTA) or Stylus Rake Angle (SRA)
4. Overhang

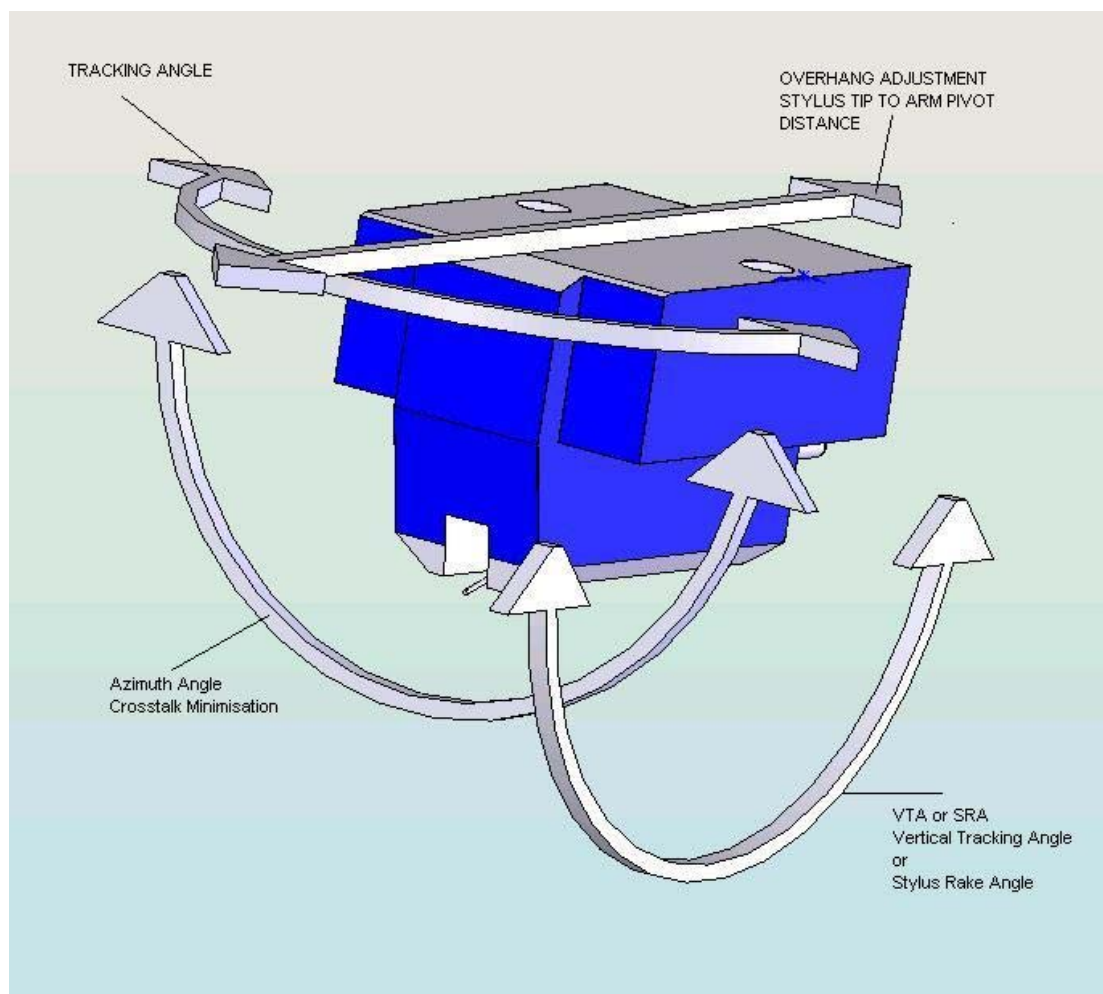

CAUTION

On the internet there are many resources available for learning about cartridge setup. However we urge caution in following some of the recommendations found on user groups and bulletin boards. Some of these tips are not based on sound engineering principles, and can damage your cartridge.

CAUTION

Do not connect any voltage or electrical meter directly to tonearm cables which are connected to a cartridge. If you use the wrong type of meter you can destroy a cartridge coil mechanism. If you are unsure of the equipment you are using to adjust azimuth please contact your Authorised Continuum Consultant.

Please refer to manufacturer instructions in all cases before trying any “tweaks”. Failure to consult manufacturer instructions can result in a voiding of any warranties or responsibilities.

INSTALLATION

This Manual is for Factory Authorized Installers and technically proficient users who are familiar with phono cartridges and tonearm installation terminology and concepts.

The main steps of installing the Copperhead are:

1. Disassembly to enable mounting to armboard.
2. Installation of the central tower mount.
3. Re-assembly of main arm components.
4. Adjustment of pivot height relative to platter height.
5. Weighing your cartridge
6. Selecting the Weighted Washers to match Cartridge Weight.
7. Installing Cartridge on Wand.
8. Attaching Cartridge clips
9. Installing Wand on pivot assembly.
10. Securing the Arm Cable to Turntable
11. Balancing the wand and setting tracking force.
12. Connecting anti-skate string.
13. Grooming the Tonearm Wire.
14. Adjusting of anti skate force.
15. Adjustment of azimuth for initial cartridge setup.

COPPERHEAD COMPONENTS

The Copperhead comes to you with the main components assembled, and needs to be partially disassembled for installation.

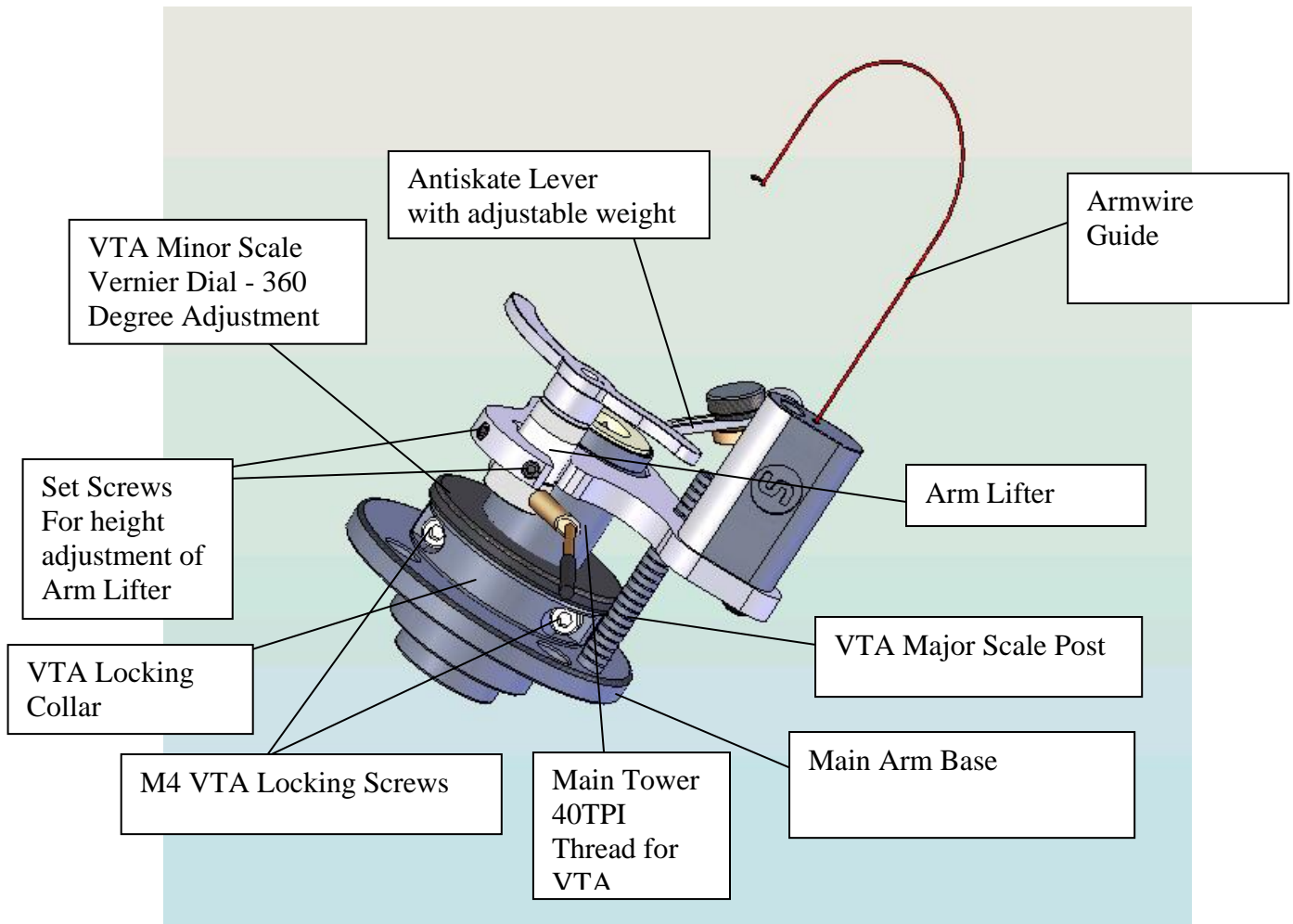

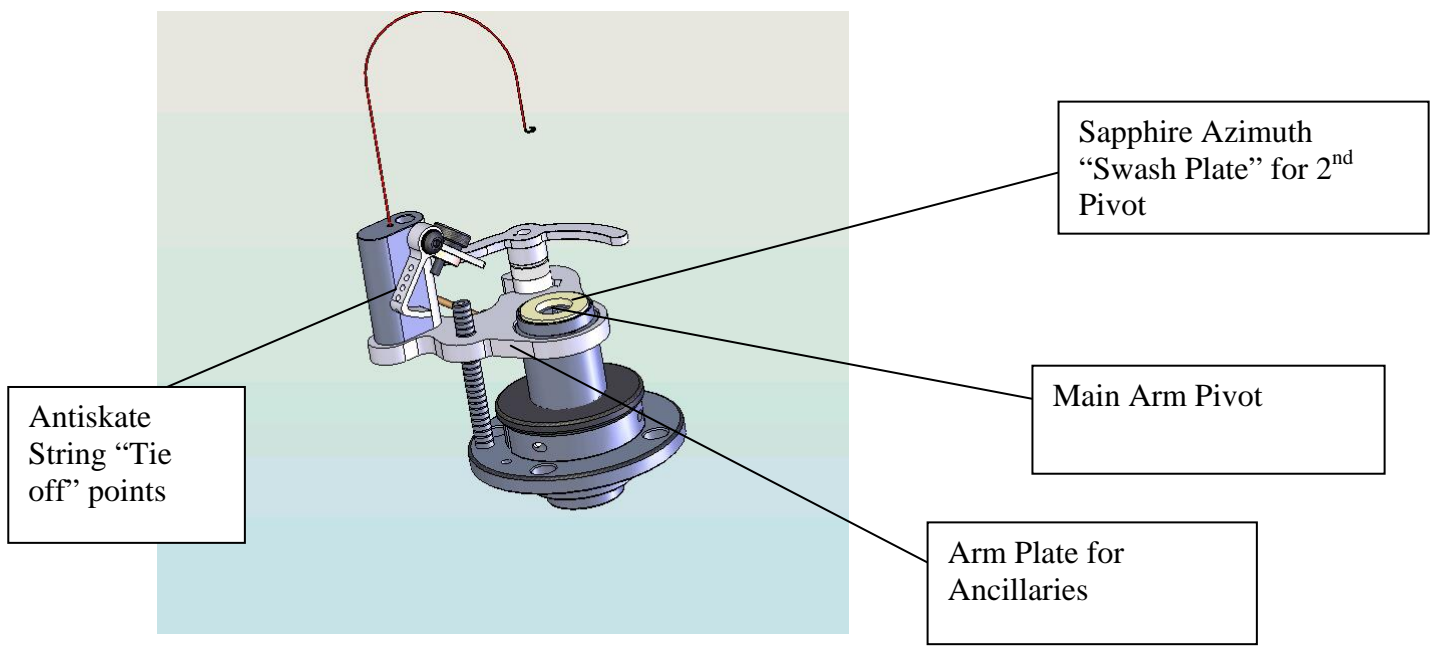

DISASSEMBLY FOR MOUNTING PROCEDURE

Use a suitable allen key to undo the 2 x M4 VTA locking screws which are used to tighten the VTA Locking Collar on to the Main Arm Tower.

Slide the central Main Arm Tower off the main body

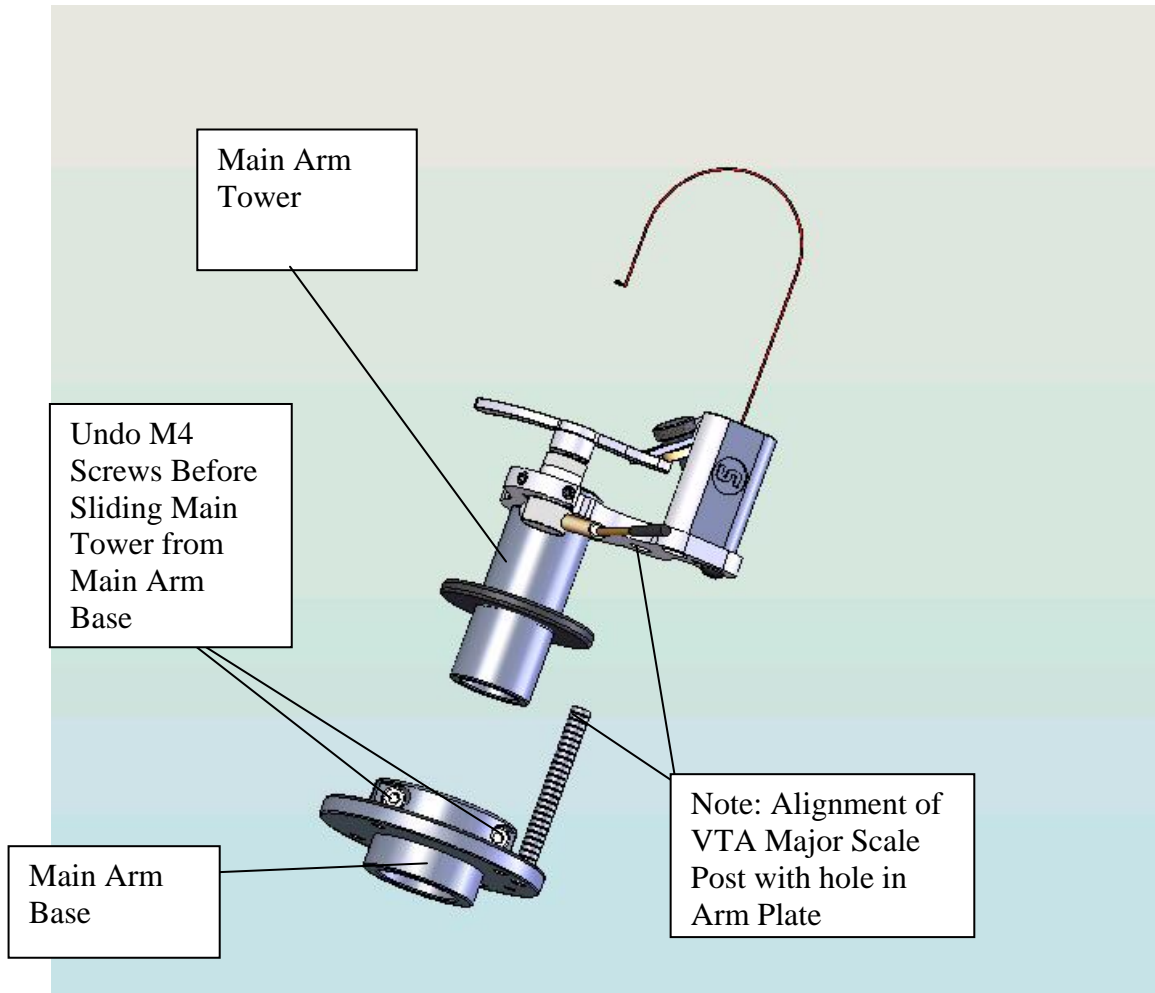

NOTE: take notice of how the central tower fits through the main arm mount, for when you have to reassemble it. You are now ready to mount the Arm Mount to the Armboard.

TO NEARM PIVOT TO RECORD SPINDLE DISTANCE

PIVOT TO SPINDLE DISTANCE IS 221.7mm.

Using the supplied template mark out and drill holes in the armboard as shown below.
 Note: This has been predrilled for Criterion users. We recommend you use 4mm Socket Head Cap Screws and professionally drill and tap the plinth or armboard to allow the arm to be bolted directly to the plinth. **Note: Criterion Copperhead predrilled at the factory.**

Note: If the plinth requires a cutout to access a sub-chassis then the main arm mount requires a 72-80mm hole to be cut to allow for clearance.

All dimensions are in METRIC i.e millimeters.
 PCD for M4 Screws is 56mm
 HOLE for ARMTOWER is 44mm diameter by minimum 50mm deep.

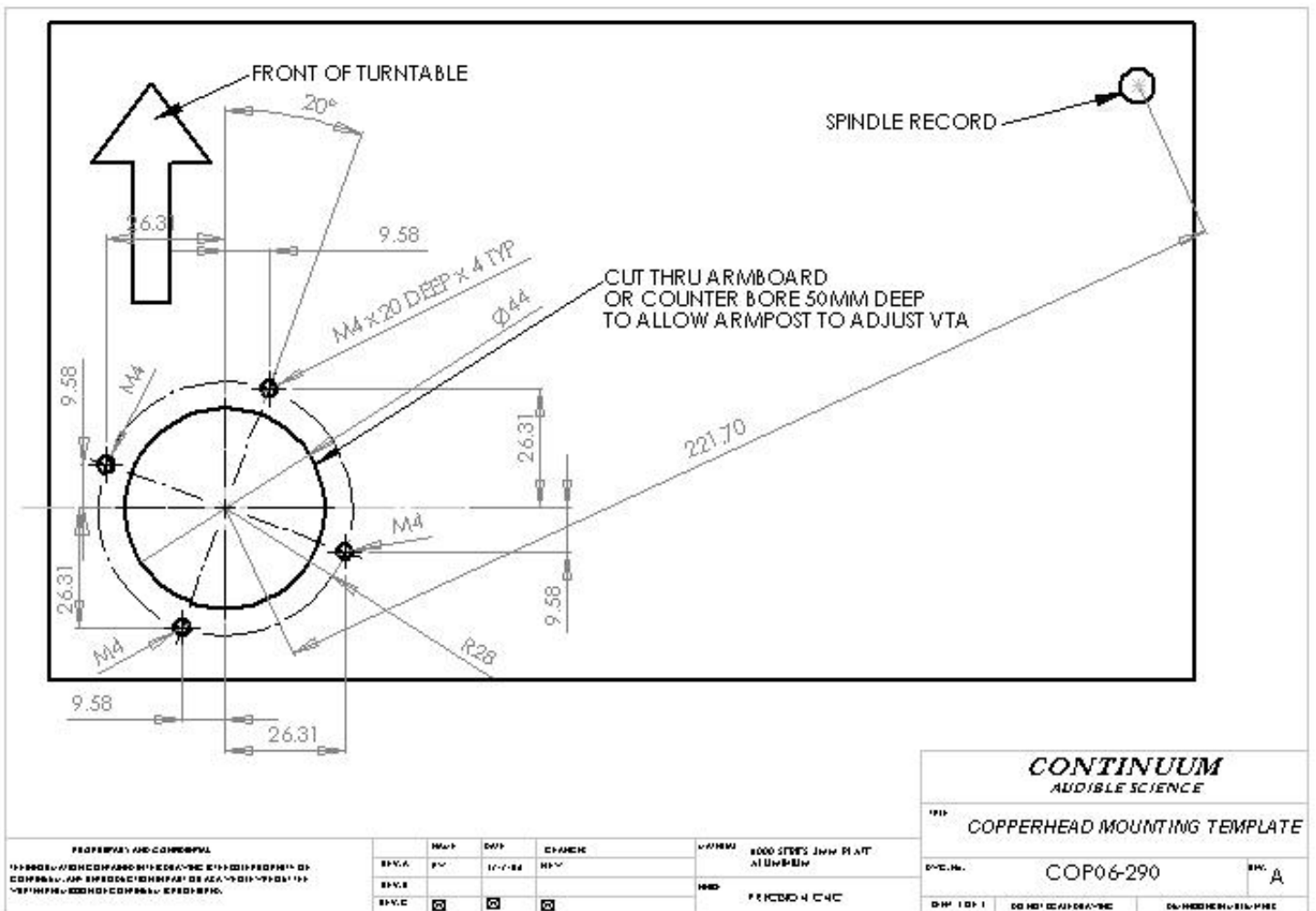

MOUNTING THE MAIN ARM BASE TO THE ARMBOARD

Position and screw the Main Arm Base into the armboard (or your turntables arm mounting mechanism) using 4 off M4 x 16mm Socket Head Cap Screws.

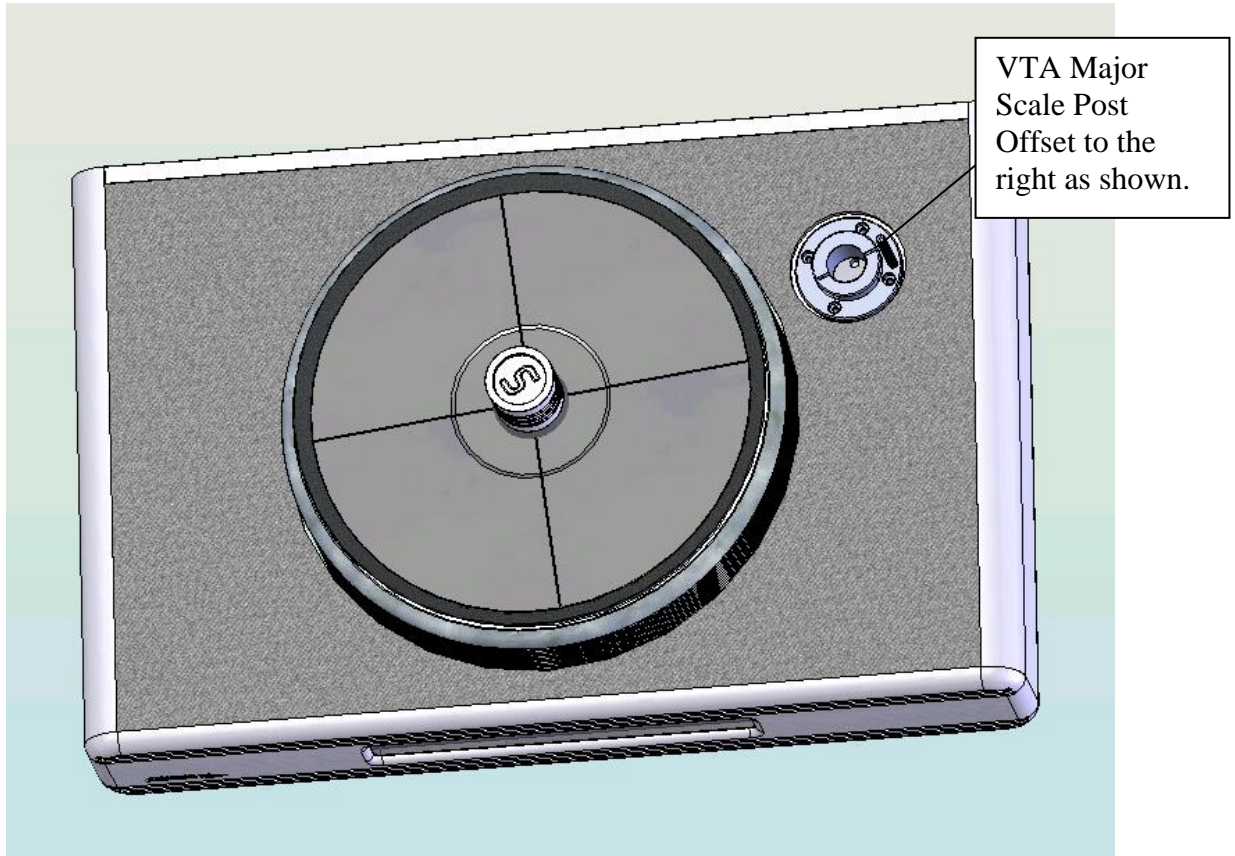

Note the position of the VTA Major Scale Post is offset to the right of the platter.

MOUNTING THE MAIN ARM TOWER TO THE MAIN ARM BASE

Position and lower the Main Arm Tower into the Main Arm Base taking care to align the VTA Major Scale Post into the Arm Plate.

Rotate the VTA Minor Scale Vernier clockwise (to raise) or counter-clockwise (to lower) the Main Arm Pivot to sit level with the top surface of the LP on the platter. This is a basic starting point for initial VTA and weight adjustments.

Tighten the two VTA Clamp M4 Locking Screws to lock the Main Arm Tower into the Main Arm Base.

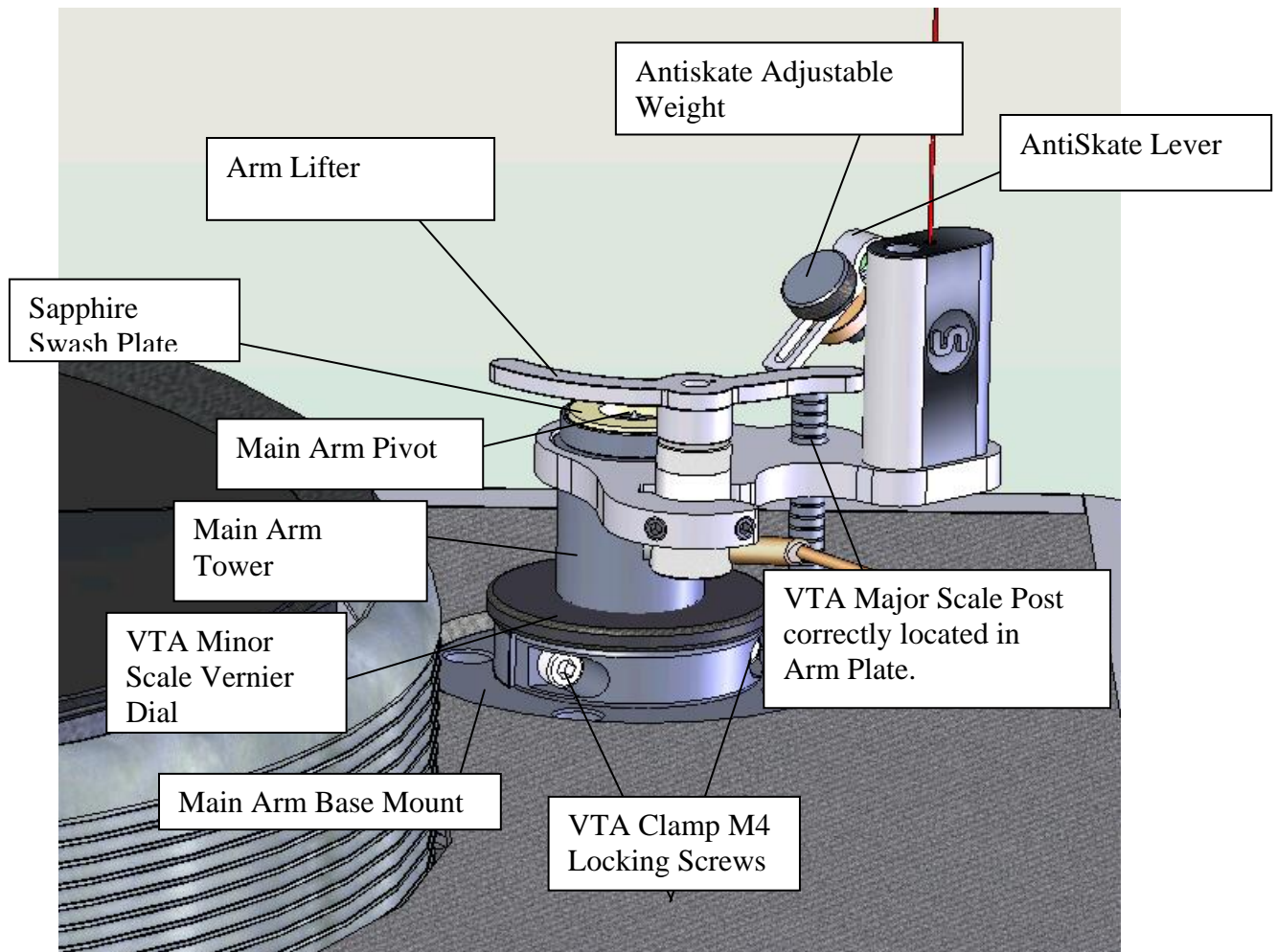

VTA (SRA) SETUP HOW TO ADJUST VTA (SRA)

At the front of the Main Arm Mount there are two M4 Socket head cap screws. These need to be gently loosened in order for the Main Arm Tower to be raised or lowered using the VTA Minor Scale Vernier Dial at the top of the main arm mount.

Rotate the VTA Minor Scale Vernier clockwise (to raise) or counter-clockwise (to lower) the Main Arm Pivot to sit level with the top surface of the LP on the platter. This is a basic starting point for initial VTA and weight adjustments.

For initial setup, use a ruler or straight-edge to sit on the platter and allow it to protrude over the edge of the platter and rotate over the main arm pivot. Adjust the height of the Main Arm Tower until the surface of the platter and the tip of the main arm pivot are in line. There is a Major Scale Vernier Post on the right hand side of the Arm Plate. This is complemented by a minor scale vernier at the top of the VTA Minor Scale adjustment ring.

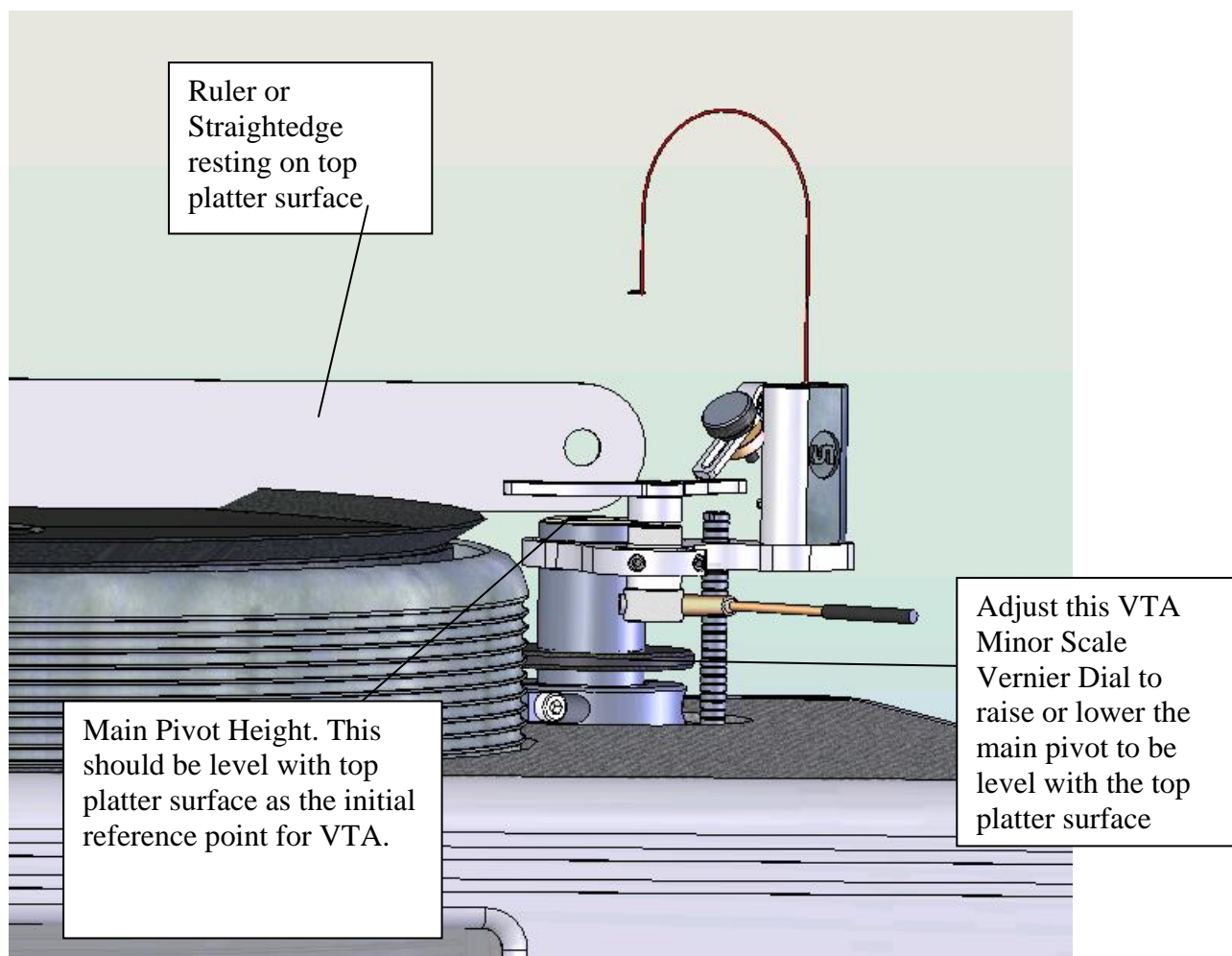

Once you have completed the setup of the tonearm and cartridge you can readjust the VTA to suit your musical tastes. Raising the VTA will tend to lean out the sound whereas lowering the VTA will tend to accentuate bass response. Optimal settings vary from LP to LP and also according to thickness of the LP. Careful experimentation is needed to find the "sweet" spot.

COPPERHEAD ARMWAND LAYOUT

MAIN WAND ASSEMBLY - UNDERSIDE

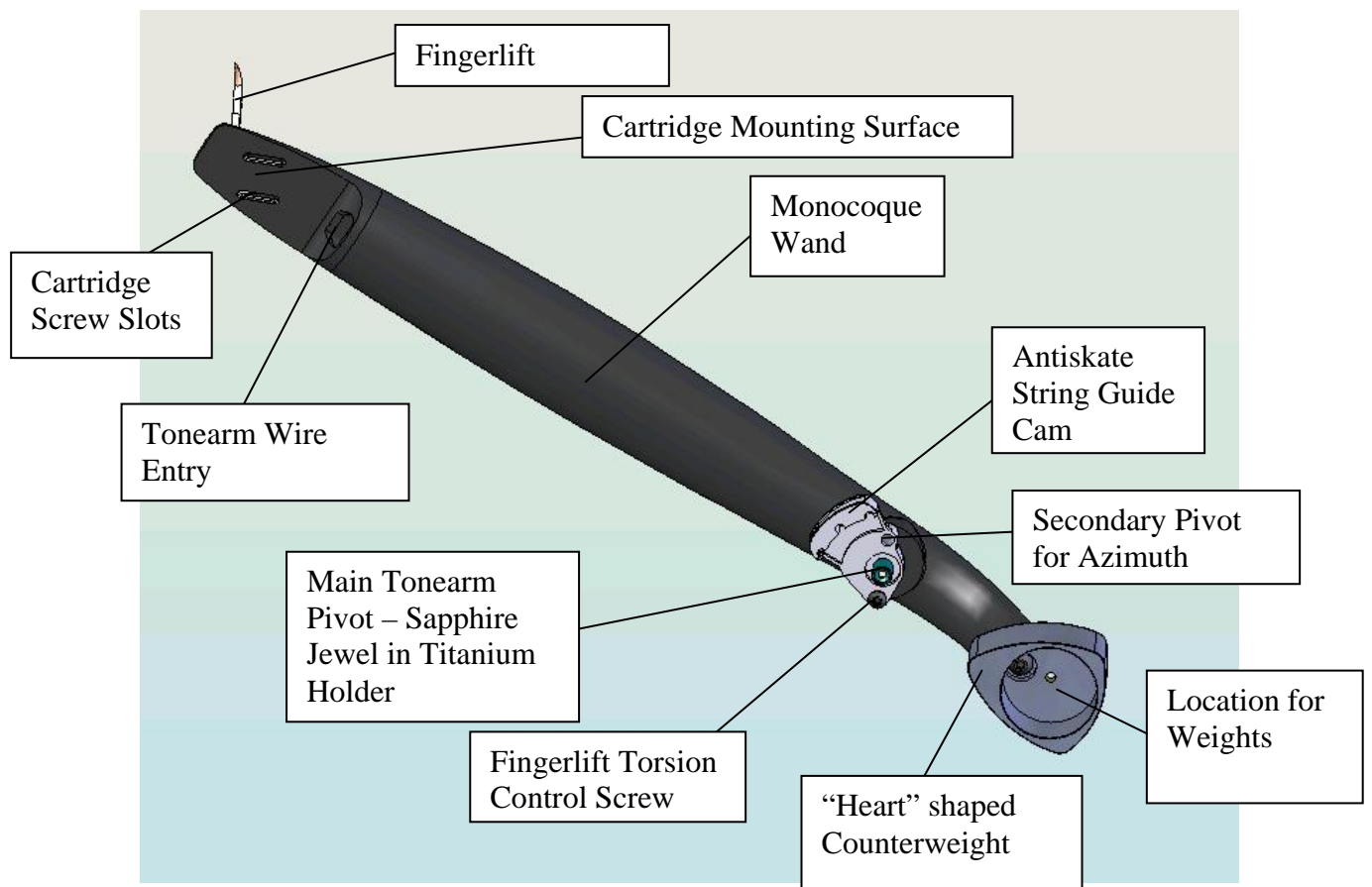

MAIN WAND ASSEMBLY – TOP SIDE

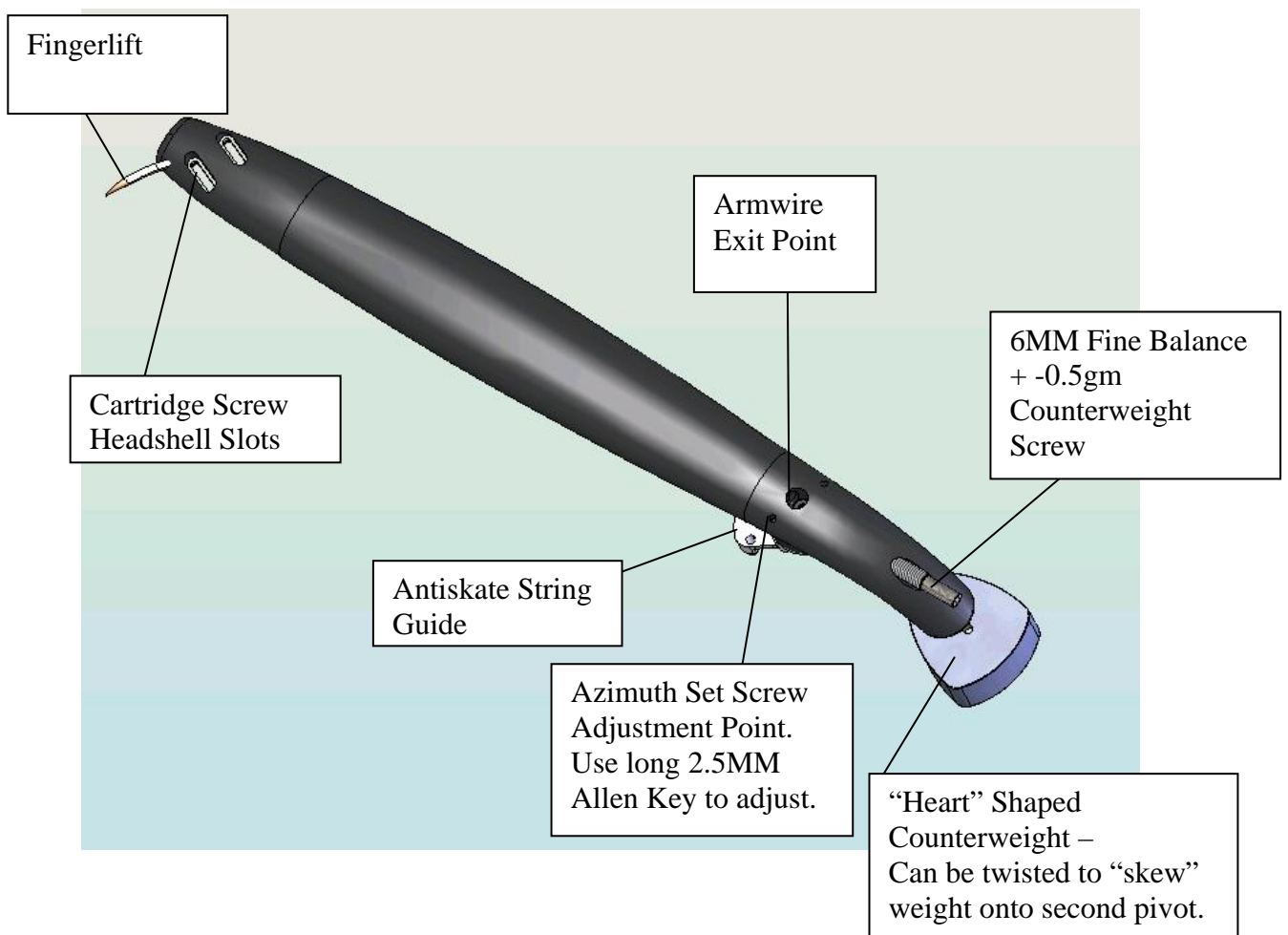

HOW TO MOUNT THE ARMWAND

The Copperhead is designed to sit on the main pivot and rely on gravity to keep it in place during operation. The secondary pivot stabilizes the arm and allows for azimuth adjustment.

A third anti-torsion screw is used to prevent “rocking” the arm when manually cueing the arm using the finger lift. This helps protect the stylus.

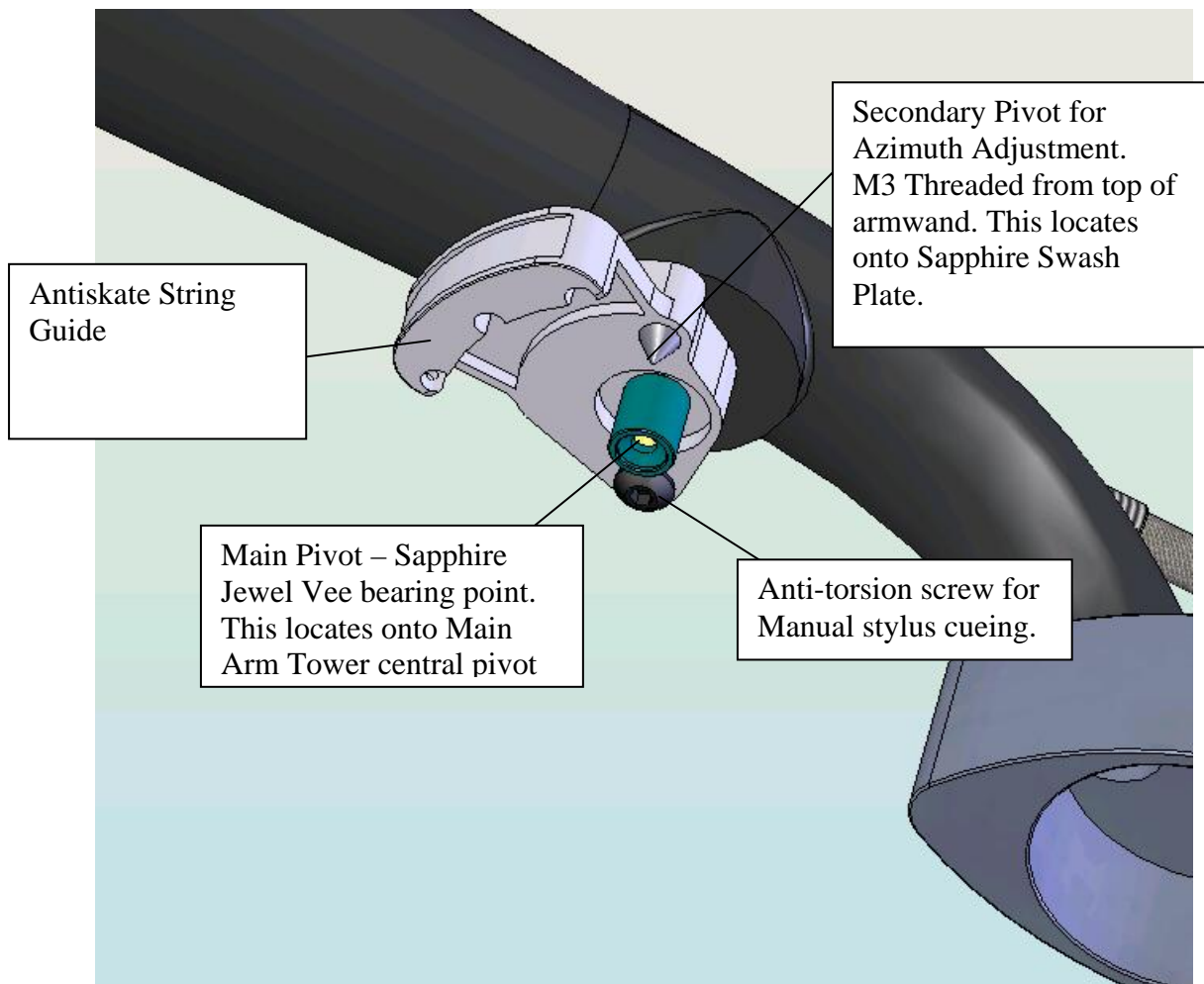

To mount the arm wand, gently place the armwand Main Sapphire Vee Jewel bearing cup directly on to the center arm pivot on the main arm tower. Gently rock the arm back and forth to confirm the jewel has seated correctly.

The tone arm is now held in place by gravity. There is no need to adjust any bearing tension or slack.

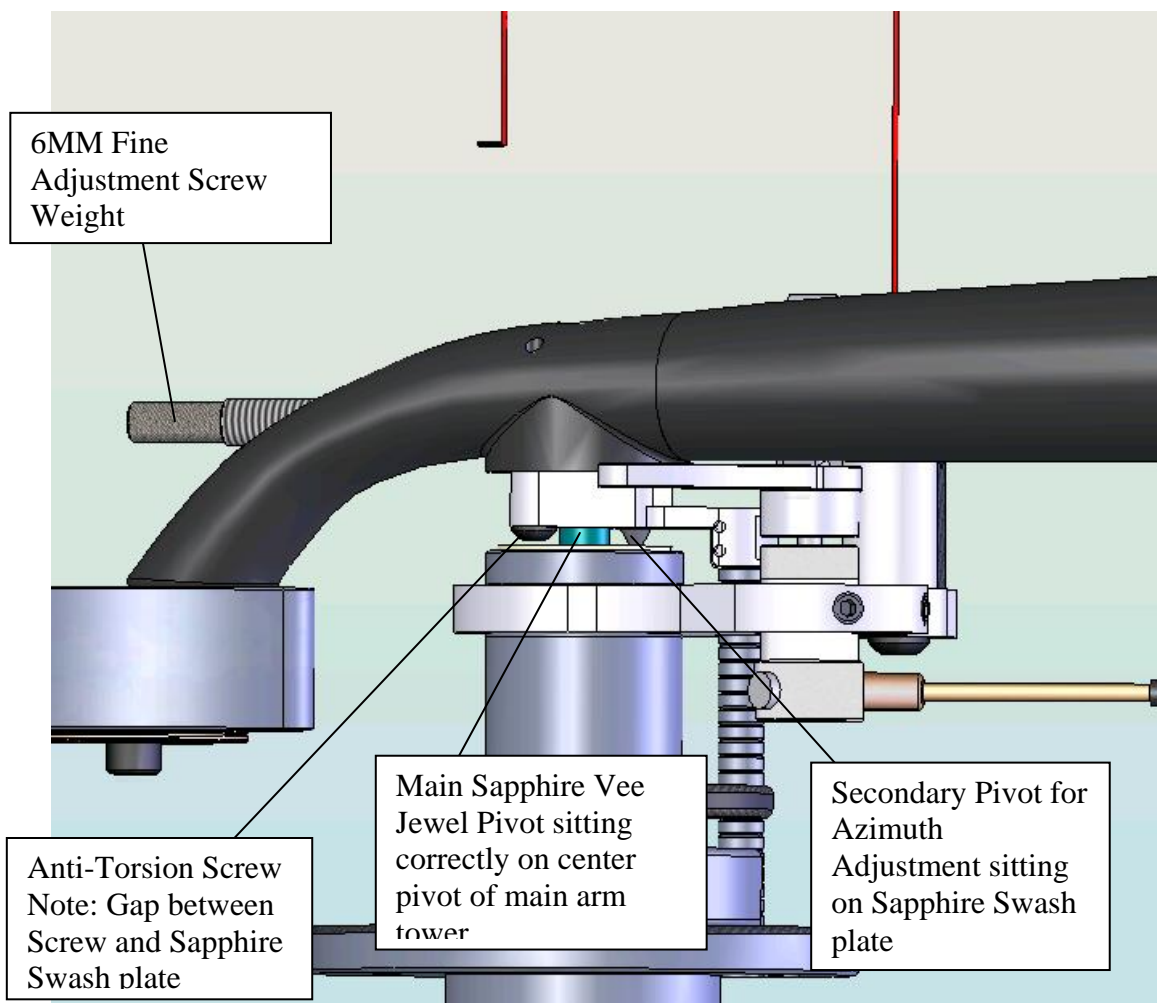

SKEWING THE REAR MAIN “HEART” SHAPED COUNTERWEIGHT

The Copperhead Arm uses two pivots. The primary pivot for rotation and the secondary pivot for azimuth control. To ensure the correct force is applied to the secondary azimuth stabilising pivot the user can “skew” the “heart” shaped main counterweight slightly to the right when viewed from above. Retighten the screw under the “heart” shaped weight to lock the “skew” angle before inserting the “washer weights for final VTF.

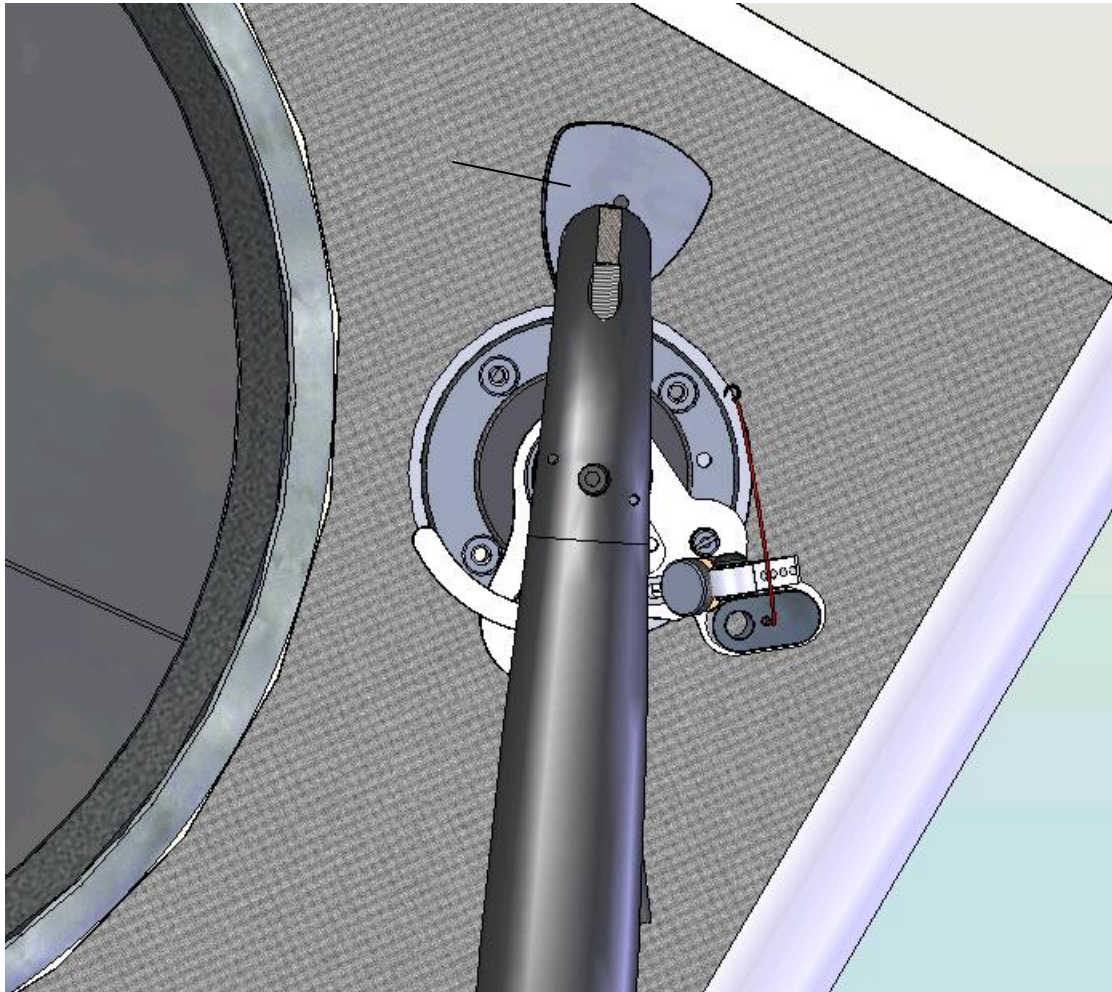

BALANCING THE ARMWAND

Balancing any tonearm is a delicate operation requiring steady hands and a set of fine scales, accurate to 0.01 of a gram or better. The Copperhead's shape optimized counter weight is a fixed distance from the arm pivot, but is fully adjustable by means of adding or subtracting a series of precisely weighted "washers".

Under the counter weight is a hollow section where "washers" of varying thickness can be added or removed to balance the cartridge. These weights are used to establish the tracking force close to optimum.

Final adjustment to precise tracking force is accomplished by winding the 6mm fine weight adjustment screw at the rear of the arm. Winding in, increases tracking force, winding out decreases the tracking force. In 0.001 gram increments a total of + or - 0.5 Grams is possible with the 6MM Fine Weight Adjustment Screw.

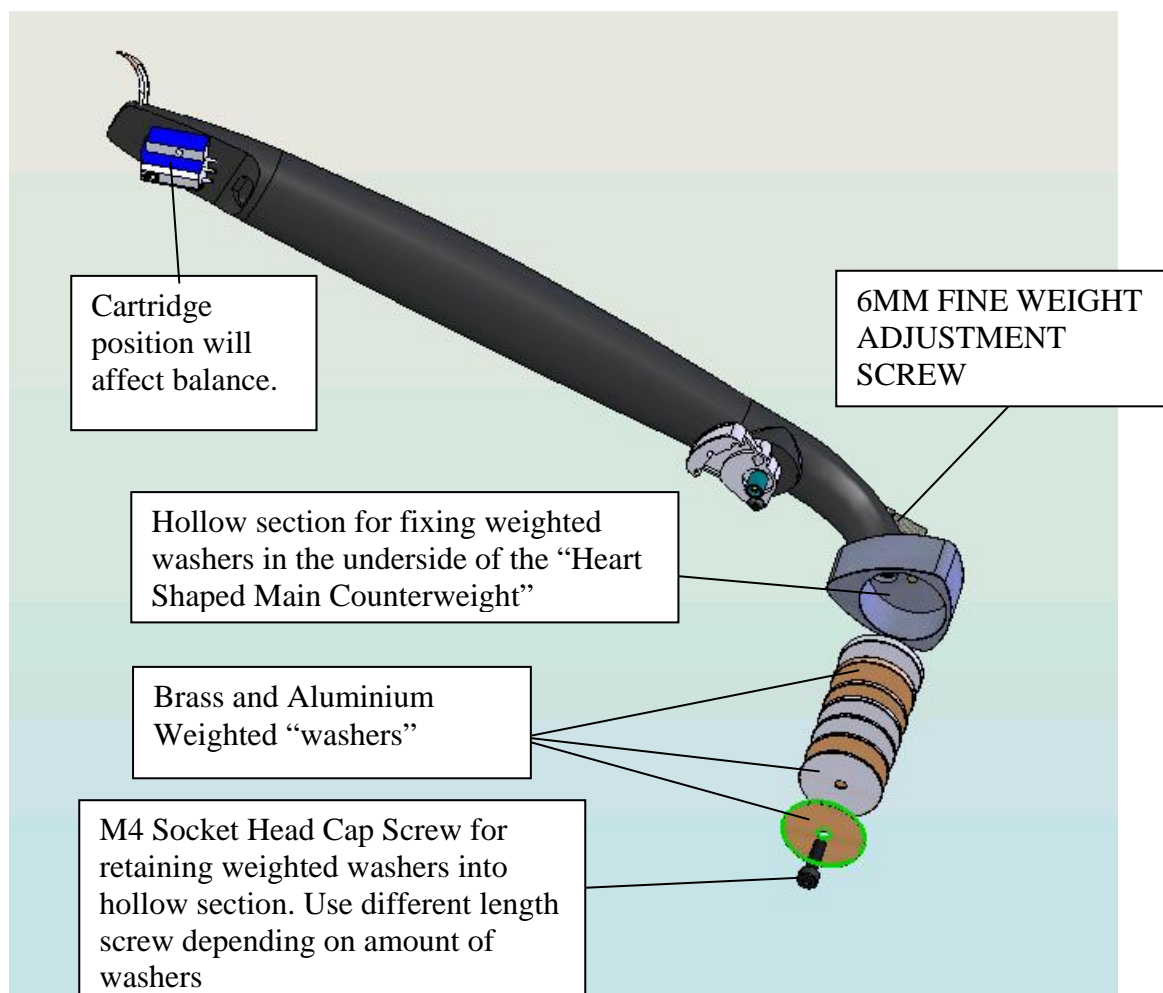

Balancing the armwand takes a little preparation but is straightforward as explained below.

The recommended steps are:

1. Weigh your cartridge before installing it on the arm. Record the weight on a piece of paper.
2. Weigh the cartridge stylus protector and record this information on a piece of paper (Note- Assumes the cartridge comes with a stylus protector. Some cartridge manufacturers do not provide this feature, so this is optional)
3. Consult the Cartridge Weight & Balance Table below for selecting the amount of weights you will use to get “into the zone” for final adjustment.
4. Install the suggested counterweight washers in the underside of the “Heart” Shaped Counterweight.
5. Install the cartridge in the headshell
6. Test the VTF (Vertical Tracking Force) using a quality scale.

CARTRIDGE WEIGHT & BALANCE TABLE

CARTRIDGE WEIGHT & BALANCE TABLE	
For Nominal Vertical Tracking Force (VTF) of 2 grams +/- 0.1 grams. Note: With cartridge placed at close to center of the headshell slots	
Your Cartridge Weight in Grams	Counterweight required with M4 Bolt in Grams
5.0	7.7
5.5	10.2
6.0	11.5
6.5	12.8
7.0	15.4
7.5	16.8
8.0	17.9
8.5	20.3
9.0	21.9
9.5	23.8
10.0	26.0
10.5	27.4
11.0	29.5
11.5	31.4
12.0	32.8
12.5	34.4
13.0	36.3
13.5	37.6
14.0	40.0
14.5	41.8
15.0	43.6
15.5	45.2
16.0	47.1
16.5	48.7
17.0	50.8
17.5	52.4
18.0	54.2
18.5	55.5
19.0	57.9
19.5	60.2
20.0	63.4

COPPERHEAD COUNTERWEIGHT “WASHER” KIT

The Copperhead Counterweight kit comes supplied with a variety of brass and aluminium weight “washers” with matching length M4 screws. Weights of each sized “washer” are listed in the table below.

WEIGHTS	
Brass Big (3MM)	15.9
Brass Mid + (2MM)	10.4
Brass Mid – (1.5MM)	7.7
Brass Small (1MM)	4.9
Aluminum Big (3.5MM)	5.3 x 2
Aluminum Mid + (2MM)	3.4
Aluminum Mid - (1.5MM)	2.5 x 2
Aluminum Small (1MM)	1.6

EXAMPLE: BALANCING A 15 GRAM CARTRIDGE

Example of balancing a 15 gram Cartridge placed at the center of the headshell slots.

1. Lookup the Weight and Balance Table till you see the 15 Gram Cartridge weight in the left most column.
2. Read across to the right hand side of that row to see you need around 43.6 grams of “washers” to add to the underside of the “heart shaped counterweight” which is fixed to the arm.

Your Cartridge Weight in Grams	Counterweight required with M4 Bolt in Grams
15.0	43.6

3. So you would need the following complement of weights to get close to optimum major balance before using the 6MM Fine Adjustment Screw at the rear of the tonearm for the final +/- 0.5 gram adjustment range.
4. Therefore select the following weighted “washers” and an M4 Screw which is long enough to secure all the washers with about 3-4mm of spare thread. Note this screw length alters depending on the amount of washers you use. A full complement of screws is provided with the arm.

Weight Washers for 15 Gram Cartridge are:

1 off Brass Big (3MM)	15.9
1 off Brass Mid + (2MM)	10.4
1 off Brass Mid – (1.5MM)	7.7
1 off Brass Small (1MM)	4.9
1 off Aluminum Mid - (1.5MM)	2.5
1 off Aluminum Small (1MM)	1.6
Plus 1 off M4 Screw to hold washers	0.6
Total Weight for 15 Gram Cartridge	44

5. Add these weights to the underside of the Heart Shaped Main Counterweight and secure with appropriate length M4 Socket Head Cap Screw.
6. Mount your cartridge in the middle of the cartridge screw slots in the headshell.

1. Where possible use the cartridge stylus protector and leave it on the cartridge whilst setting initial VTF. Weigh the protector separately and factor this additional weight to any readings on the scale. By subtracting the weight of the cartridge protector from any reading you can

NOTE: Please ensure the tonearm wire is loose enough not to interfere with the VTF. Tonearm wire should be looped over the Tonearm Wire Guide and exited as close to vertical over the main tonearm pivot.

INSTALLING CARTRIDGE ON WAND

CAUTION

We recommend the cartridge should be installed with the arm wand removed from the pivot and placed on a soft cloth on top of the platter or other stable, safe surface.

Ensure Cartridge Cantilever is protected during installation.

The Copperhead headshell is an integrated part of the arm wand and accepts all standard 12.7mm spacing between cartridge mounting screws. Mount cartridge in the headshell according to the manufacturer's instructions.

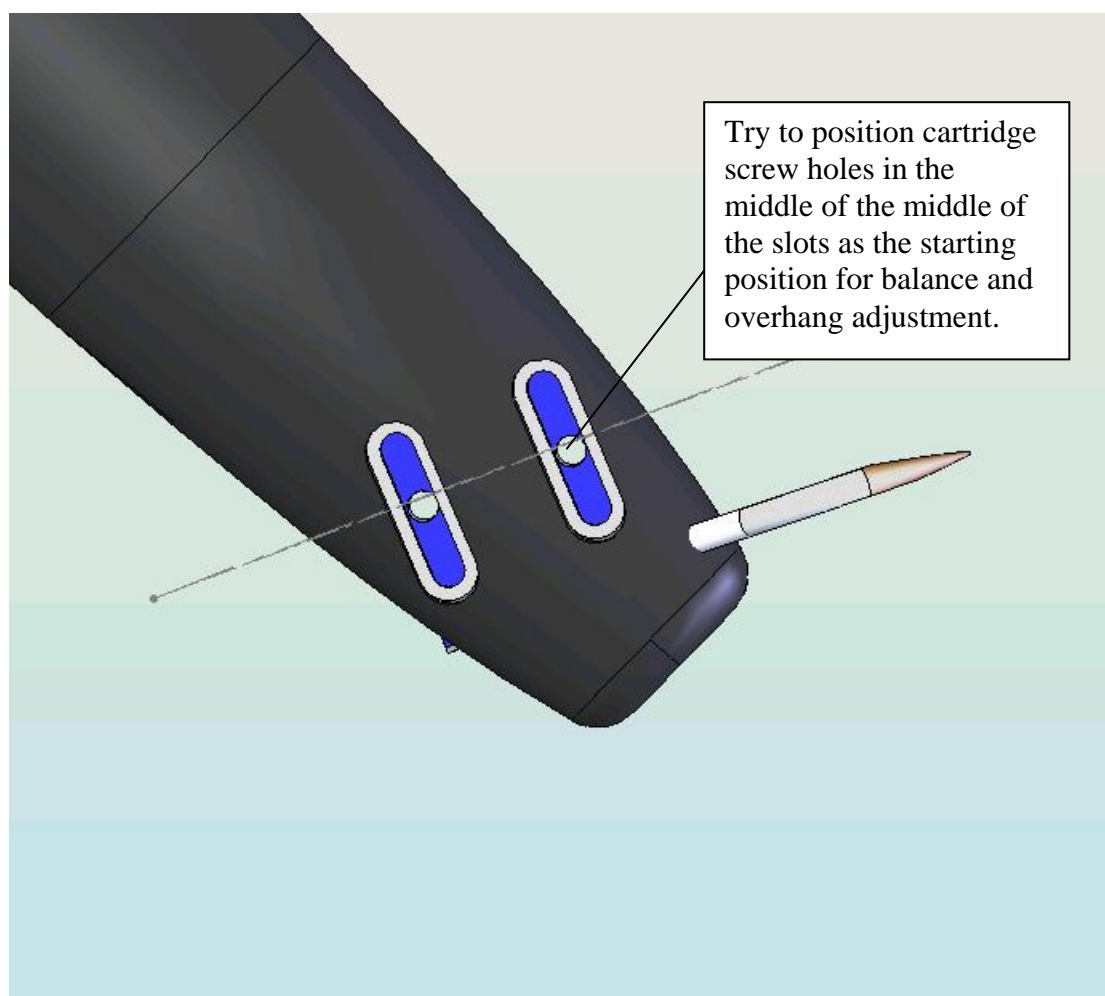

Do not force or over torque the M2.5 screws. A light "nip" is all that is required.

Connect the cartridge pins to the arm wire following the cartridge manufacturer's instructions.

Do not force the tonearm wire pins or bend and twist the wire unnecessarily as this can lead to wire breaking (requiring delicate resoldering).

OVERHANG FINE ADJUSTMENT AND VTF CHECK

Overhang is adjusted by positioning the cartridge stylus in relation to the tonearm pivot.

Your Copperhead should have been mounted correctly in a predrilled arm board which places the tonearm pivot at the optimum distance from main arm pivot to tonearm spindle. This distance is 221.7 mm when viewing the platter from above (Plan View).

Final overhang is set by moving the cartridge in the headshell slots according to the recommended tracing template using either a Baerwald, Lofgrin or Stephenson alignment to minimise tracking error.

You will need to recheck the Vertical Tracking Force (VTF) of the cartridge with any repositioning of the cartridge in the headshell.

Use the 6MM Fine Adjustment Screw at the rear of the tonearm wand to make any minor adjustments to the VTF.

If necessary add or subtract a weight washer under the heart shaped counterweight to get back into the +/- 0.5 gram weight range that is controlled by the 6MM Fine Adjustment Screw.

HOW TO CONNECT AND ADJUST THE ANTISKATE

The Copperhead uses a specially designed geometry to alter the force of the anti-skate across the surface of the record from 8% of the vertical tracking force at the start of the record to 12% of the vertical tracking force at the end of the record.

The Copperhead Arm Wand has a triangular shaped anti-skate “cam” on the underside of the arm, around the main bearing cup. You will notice a lightweight cord attached to this cam. The end of the cord is threaded through a loop on the end of the anti-skate lever and tied off with a small socket head cap screw.

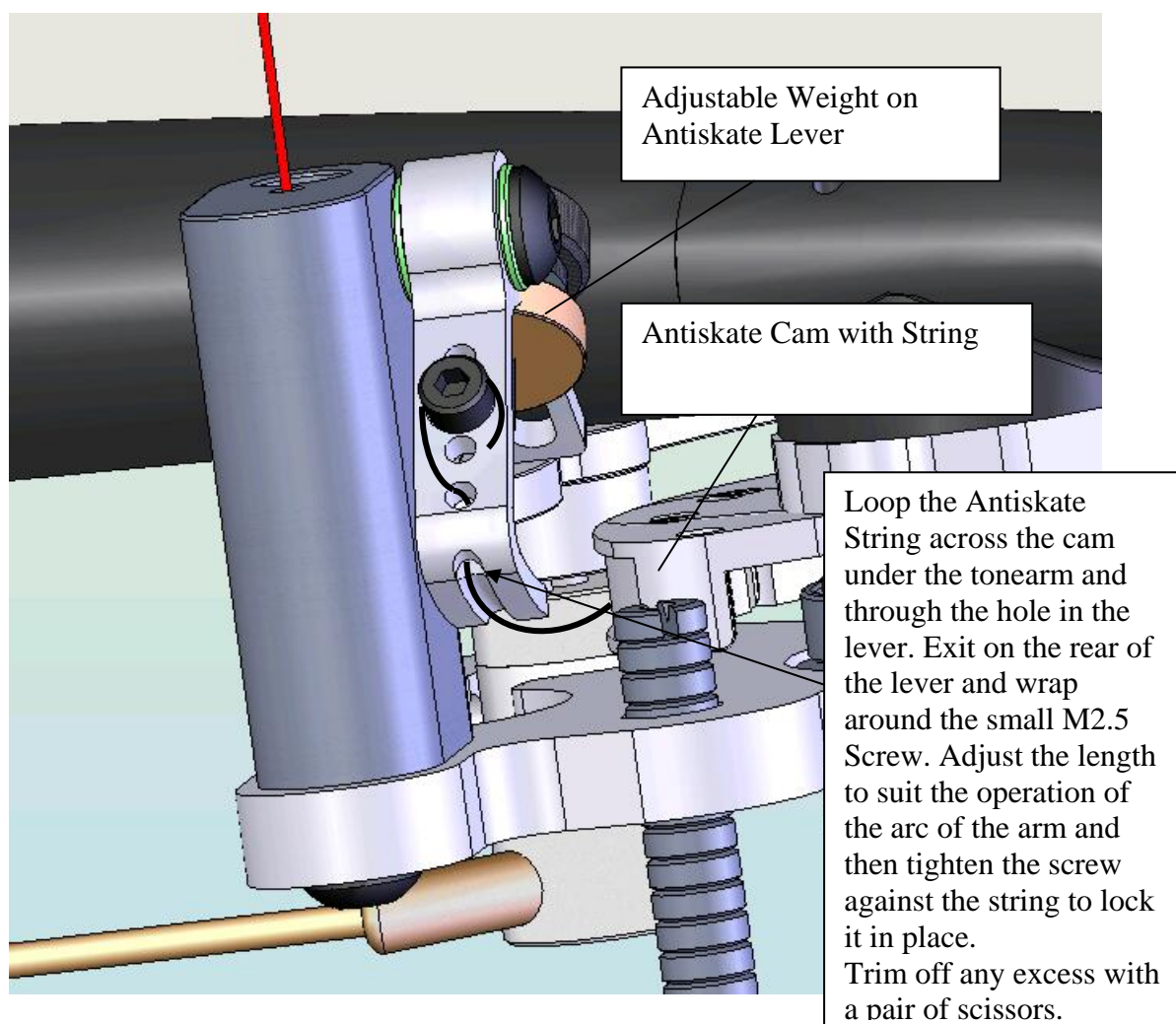

Once this cord is attached the bias can be adjusted by changing the position and the mass of the weight on the end of the anti skate lever.

Gently loosen and slide this weight up the lever to reduce anti-skate force. Slide it down the lever to increase anti-skate force. Factory settings are close to optimum, but if you need to add further weight, undo the thumb screw completely and add one of the supplied 3mm broad washers as required. Do not over tighten as the mechanism is designed to be very light to reduce inertia.

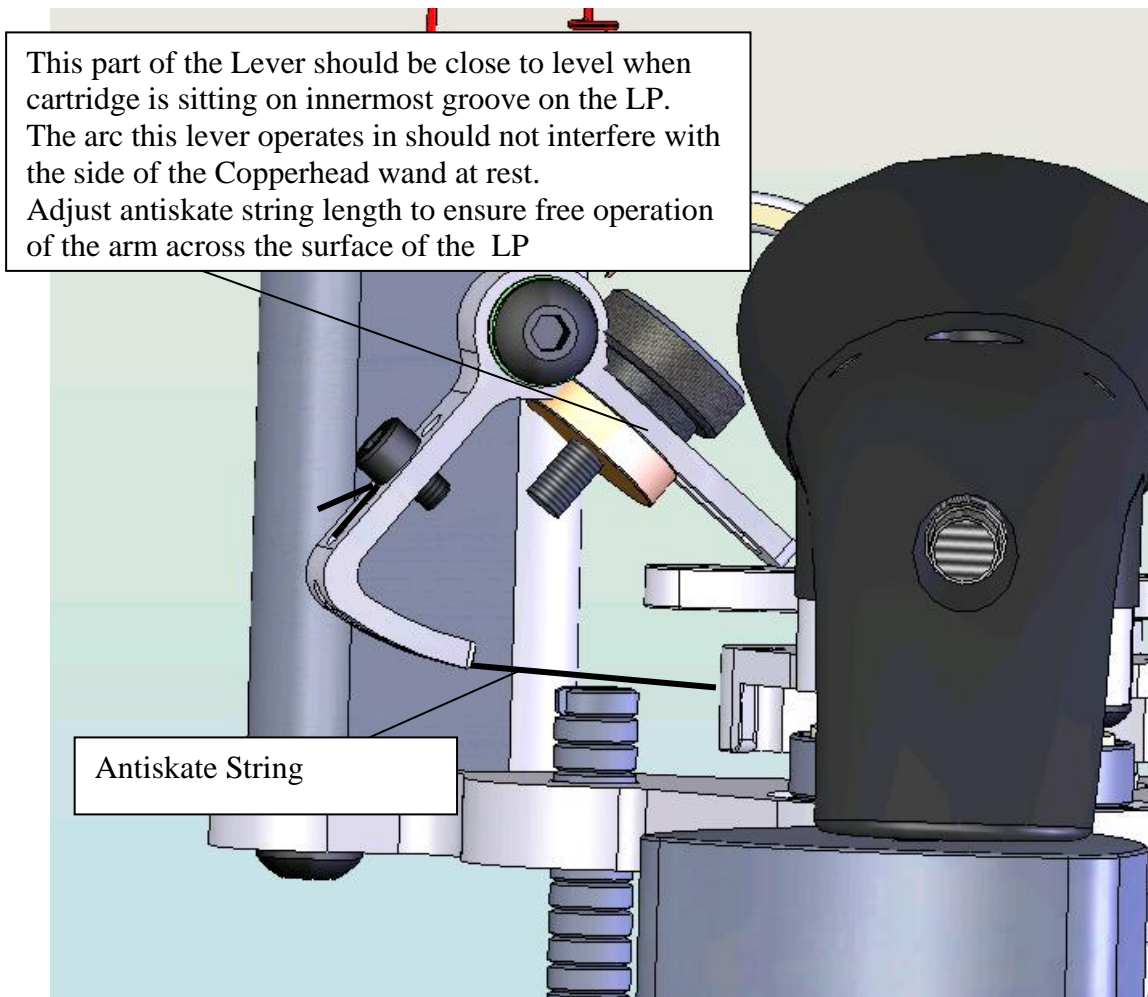

Anti-skate force should be adjusted according to a percentage of the tracking force. We recommend the use of tools such as Wally Skater from WAM Engineering to set anti-skate.

If you are unable to adjust to the correct range, try adding or subtracting the small washer weights from the lever. This is done by undoing the thumbscrew completely and adding or subtracting the 12mm penny washers with a 3mm hole. These washers are supplied in your arm kit. Please contact us if you require replacements.

Arm wires can play a significant part in anti-skate forces. That is why we have provided an arm wire guide to “groom” the arm wire to minimize torque. Ensure the arm wire is hooked through the arm wire guide centre “hook” and held directly over the main arm pivot. The arm wire exits right above the main pivot for this reason. The arm wires are also wound in opposing directions to minimize twisting forces. This then allows the antiskate lever to work at an optimum level.

GROOMING THE TONEARM WIRE

By routing the tonearm wire over the main pivot a significant reduction in skating torque being affected by tonearm wire twisting tension can be achieved.

The Copperhead tonearm wire can be “groomed” by the use of the Armwire Guide which is detachable from the holder.

Rotate and adjust the Armwire Guide to keep the exit of the tonearm wire as close as possible to vertical after it leaves the wand exit point.

Groom the wire around the Armwire Guide by “looping” it around the guide. Ensure the wire does not interfere with the operation of the wand or counterweight.

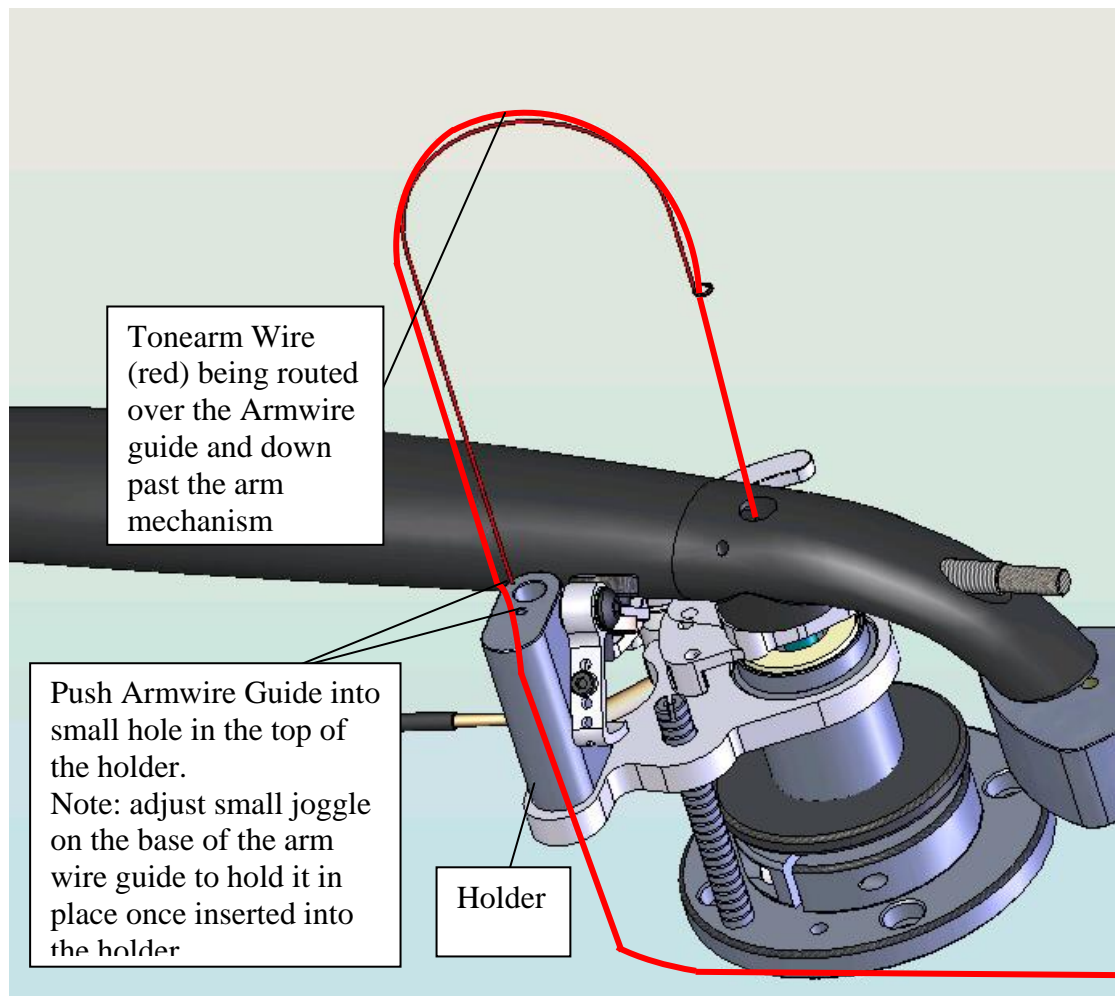

HOW TO ADJUST THE AZIMUTH

The optimum azimuth for stereo records should be based on the crosstalk between channels. This is measured by comparing the output from the left channel signal and the right channel signal using a specially cut Test Record available from quality suppliers of LP's. Examples of these LP's are the CARDAS TEST RECORD, ORTOFON TEST RECORDS etc.

Your goal for proper azimuth setting is to get the two crosstalk readings (in Decibels) to equal each other. Cartridge manufacturers do not all install their coils in a perfect 90 degree relationship to each other, nor in a 45 degree relationship with the top of the cartridge mounting surface. Therefore, there is no rule as to which direction you must tilt the cartridge.

We recommend you use a professional azimuth alignment measuring device such as a Fluke 89 Mk IV Multimeter with Decibel Function and a Test Record with Azimuth Tracks (Left Channel only, Right Channel only). If you do not have this test equipment you can try to get close by using your eye to look at the azimuth plane of the cartridge body and approximate a level position by eye. Whilst not optimum it is possible to improve the system performance by removing gross alignment errors.

WARNING: DO NOT ATTEMPT TO ADJUST THE AZIMUTH DURING PLAY AS SERIOUS DAMAGE TO THE STYLUS COULD OCCUR.

AZIMUTH ADJUSTMENT M3 SET SCREW

The Copperhead uses two pivots to stabilise the arm in the vertical plane. The main arm pivot is fixed. The secondary pivot is adjustable.

This secondary pivot can be raised or lowered by adjusting the small M3 Set Screw located adjacent to the Main Tonearm Pivot against the sapphire “swash plate” that it sits on. By raising or lowering this secondary pivot the stylus azimuth is adjusted.

The M3 Set Screw can be wound down (clockwise rotation when viewed from above) or wound up (counter-clockwise when viewed from the top).

If you look at the arm from the front on you will see a secondary pivot adjacent to the main arm pivot on the right. This is the secondary pivot that rests on the sapphire swash plate.

Use a 1.5MM Allen Key and insert it into the top of the small hole next to the main pivot towards the rear of the arm. You will feel the Allen key “engage” into the set screw. Raise or lower this set screw to adjust the azimuth.

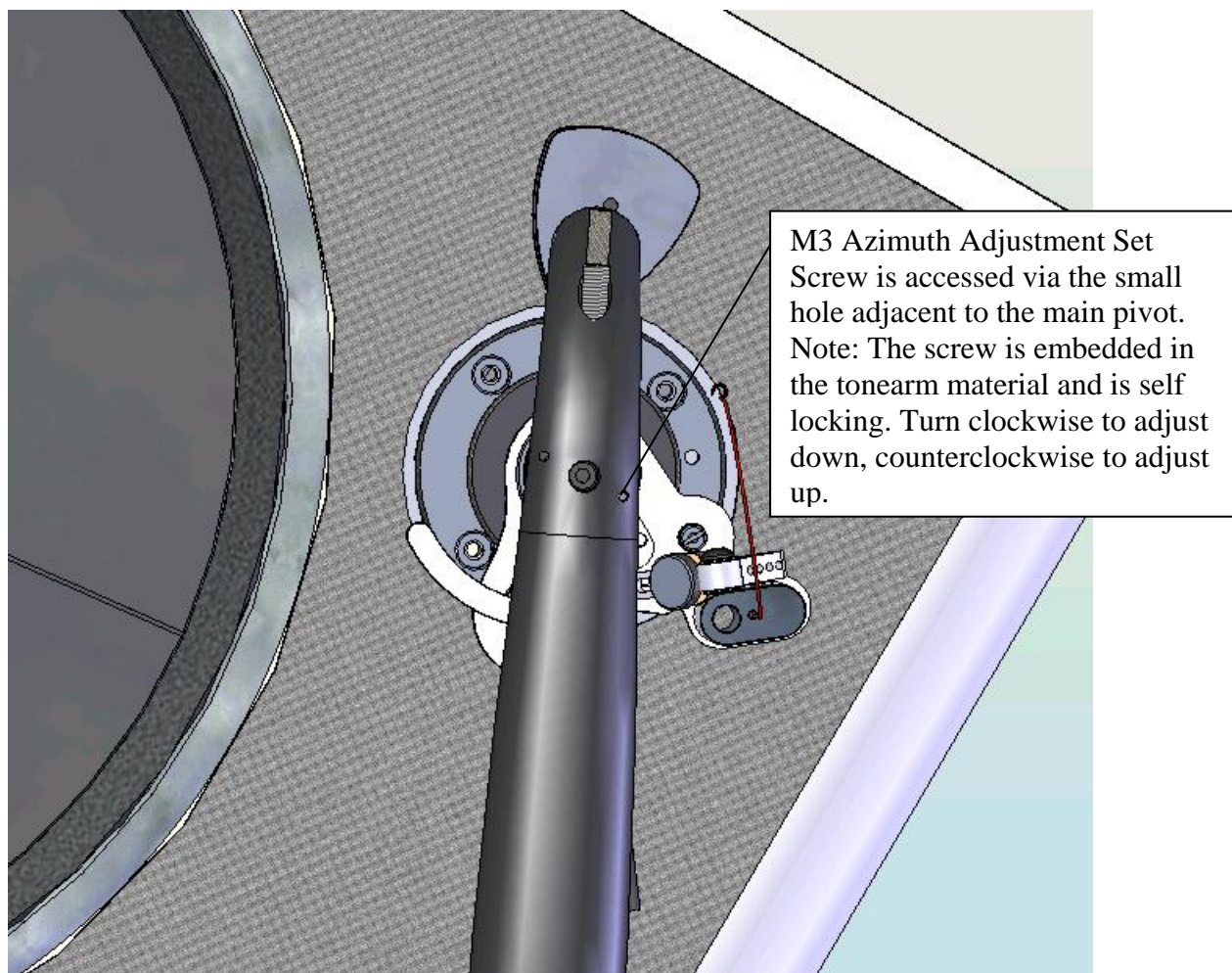

ADJUSTING ARMLIFTER HEIGHT

The Copperhead uses a compact hydraulic armlifter for safe cueing operation. The height of this mechanism needs to be adjusted to ensure enough clearance for the LP both with the arm lifted off the groove. Correspondingly when the cartridge is in the groove the armlifter needs to retract leaving enough clearance for safe unimpeded operation of the arm across the entire LP surface.

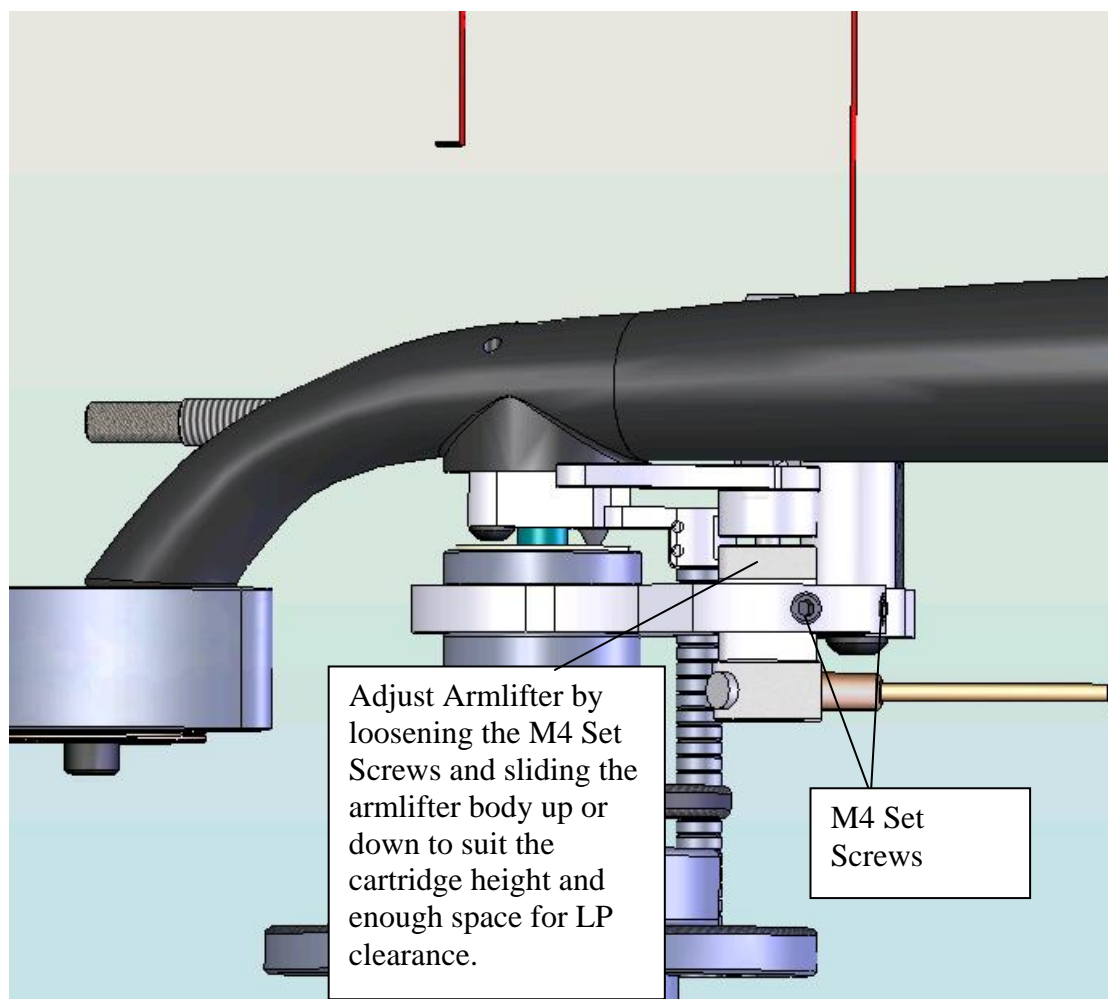

ADJUSTING ARMLIFTER ROTATION

To ensure the Armlifter does not interfere with the Antiskate Lever rotate the top of the armlifter as shown to allow for clearance. Note: You have to loosen the two M4 set screws holding the height position of the armlifter and rotate the whole mechanism without losing the height setting. .

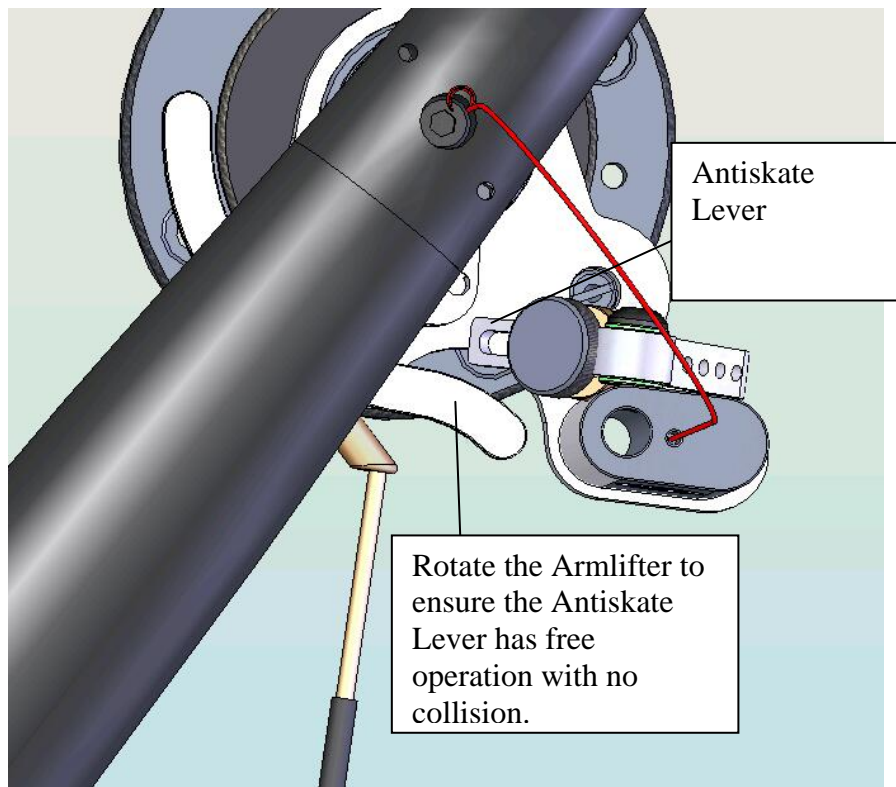

INSTALLING OR REMOVING ARMLIFTER

To install or remove the armlifter you have to remove the M2 Screw holding the armlift from the hydraulic lifting mechanism and spacer as shown below.

Insert or remove the mechanism from the arm by means of the M2 Screw.

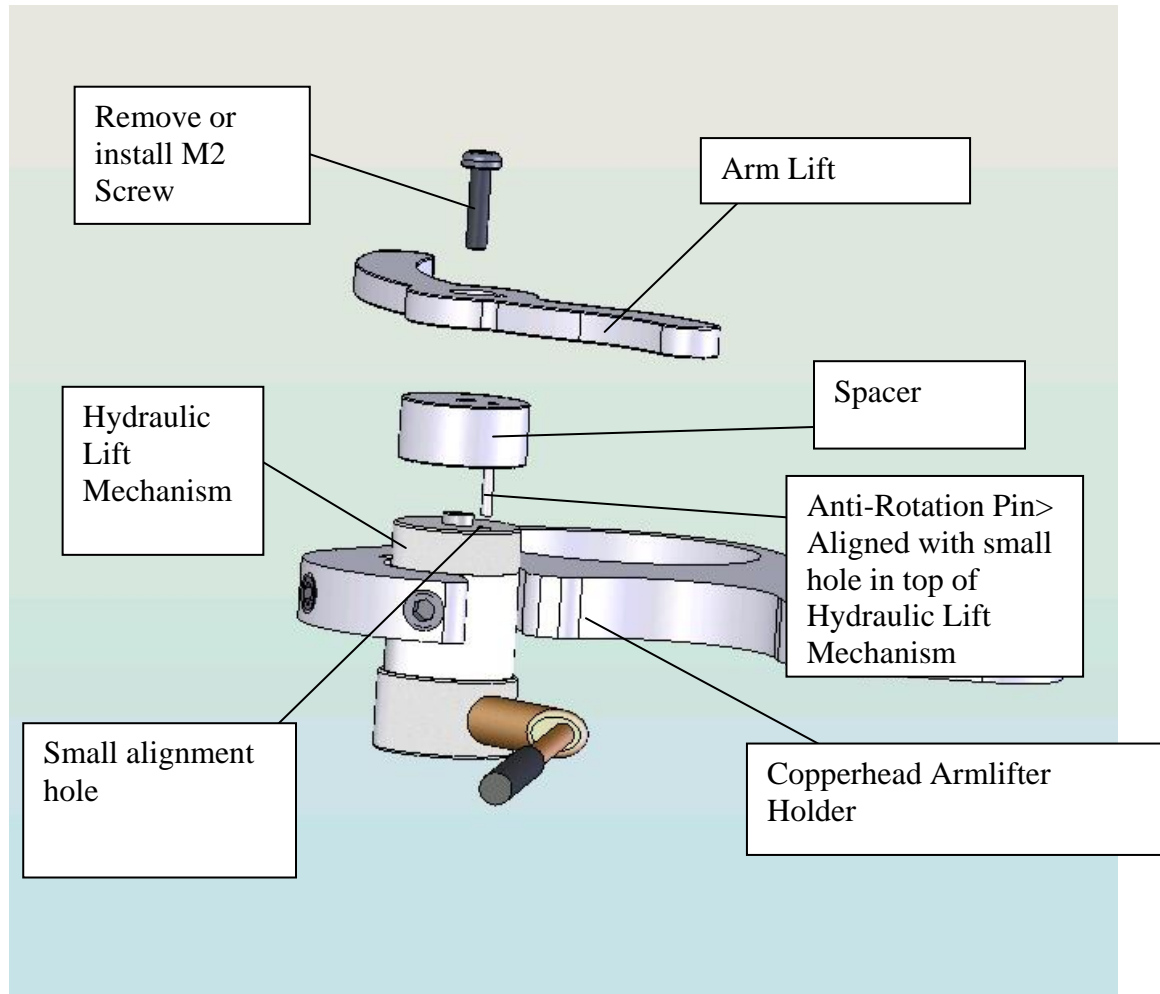

SECURING THE ARM WIRE CABLE CLAMP OR TERMINATION BLOCK

To secure the Arm Cable use the Terminal Block supplied and mount it to the rear of the Criterion Chassis (or other suitable place if using another turntable).

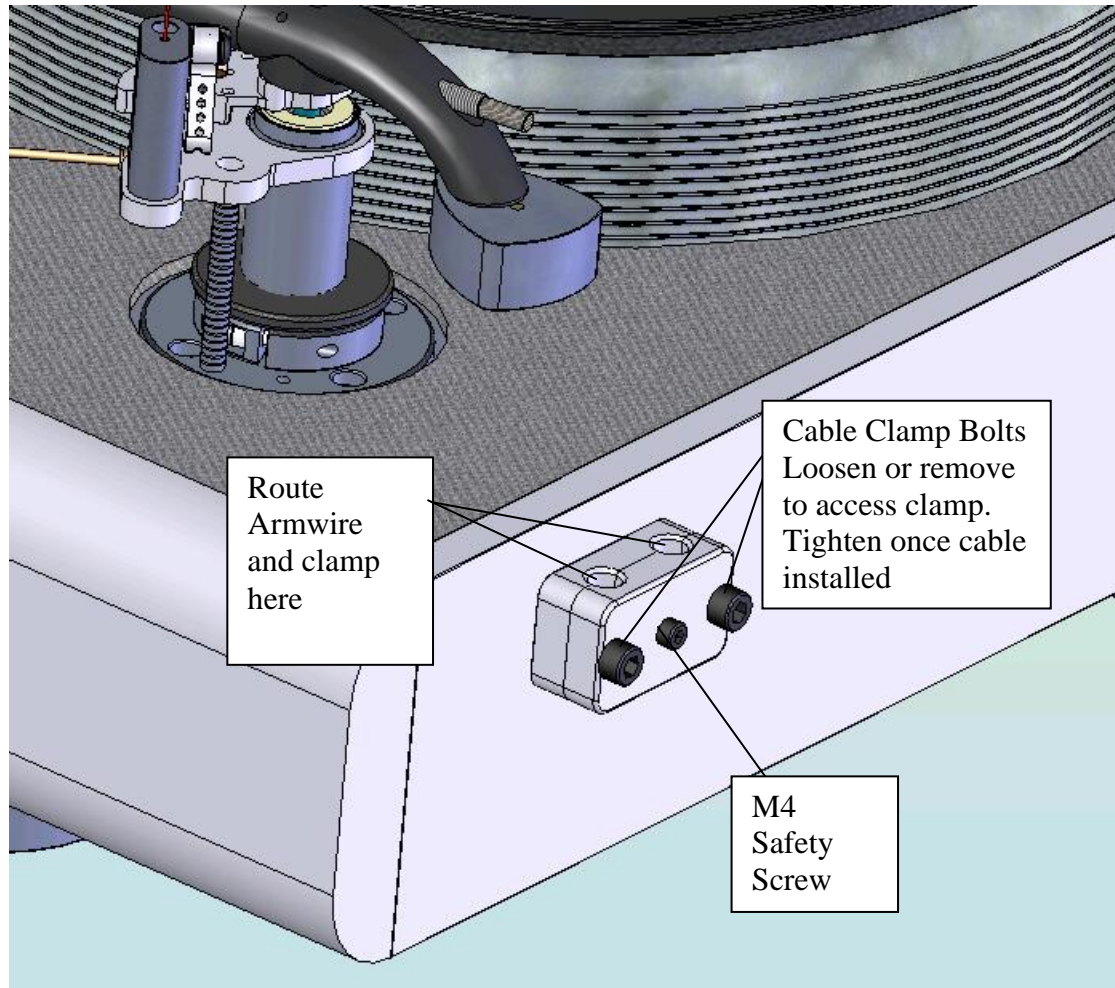

OPERATION OF THE ARM

The Copperhead tonearm is easy to operate once you have calibrated the Overhang, Tracking Angle, Azimuth and VTF.

Use the Armlifter to raise the arm. Cue the record with the fingerlift. Lower the armwand using the Armlifter and play LP.

Once the LP ends use the armlifter to raise the arm. Use the fingerlift to return the arm to the rest position.

OWNER CARE & MAINTENANCE

Your Copperhead tonearm is a delicate piece of equipment, and care needs to be taken when using, and cleaning it. Below are recommendations for keeping your Copperhead at its optimum performance.

CARING FOR METAL SURFACES

The metals we have chosen because of their superior sound qualities are susceptible to being scratched.

Do not use any window cleaning solutions, silicon based polish, abrasive pads, scouring powder or solvents such as alcohol or benzene to clean your Copperhead. Your Continuum Consultant can advise you on what products, available in your area, are suitable to use for cleaning.

CLEANING THE TONEARM

The tonearm can be cleaned using a soft, camera-lens-quality, cleaning chamois.

BEARING MAINTENANCE

The bearing is fully enclosed and requires no owner maintenance.

COPPERHEAD'S DESIGN HISTORY

The technology used to design the Copperhead arm is more in the domain of advanced military, aeronautical and automotive environments but is critical to breaking the “sound barrier” in LP performance.

Many years ago, a team of designers and engineers, under the leadership of talented Australian designer, Ben Lexcen, revolutionized the America's Cup yachting challenge by developing a “winged keel”, using advanced software design tools. This revolutionary “shape optimised” keel allowed superior performance to be extracted from the associated hull technology. At the time, it “broke all the rules” and proved itself in the field of ocean racing.

In similar fashion, the Copperhead arm presents a revolutionary breakthrough in arm design for another pursuit of ultimate performance – the quest for perfect sound. The challenges are no less daunting as the combinations and permutations are nearly endless.

What the engineers at Continuum Audio Labs did was to throw out the “rulebook”, and question the accepted wisdom of prior tonearm designs, and choices of materials.

Continuum Audio Labs chose to “go back to the drawing board” and examine the physics at play in analogue vinyl replay systems. The physics were made visible by the use of Finite Element Analysis software. The result was then worked back to a practical implementation of currently available materials and fabrication techniques.

This methodology is proven to advance technology, not by increments, but by leaps and bounds. What you are about to hear is a result of some very radical thought processes and development methodologies. You will ultimately be the judge of whether this design approach delivers an advancement of the state of the art.

Many experienced audiophiles have validated our design choices. Music lovers who have described the sound emanating from a Copperhead as being the closest they have been to a master tape or live performance.

We hope you enjoy the Copperhead as much as we do.

It's absolutely seductive!

COPPERHEAD'S DESIGN TEAM

Many very intelligent minds were brought together to push the envelope of what was imagined possible for tonearm technology, and we would like acknowledge each one of them now.

Mark Doehmann – Director Engineering & Development

Marks' passion for analogue sound reproduction, combined with his background in aeronautical and advanced software engineering and advanced materials fabrication techniques, was used to transform his vision for the Copperhead from the "virtual world" to the end product.

David Payes - Chairman, Continuum Audio Labs

David was the catalyst for the development of the Copperhead, and created the financial and creative freedom to push the envelope. David is a passionate audiophile and has had extensive input with technical design issues.

Dr Murali Murugasu MB.ChB. MBA – CEO & President of Sales and Marketing

Murali is part of the core design team at Continuum Audio Labs. His day to day involvement ensures that our products meet various regional market requirements and ensures that they work in harmony with other high quality components to deliver a complete solution.

Dr. Neil McLachlan - Professor at RMIT University's School of Architecture & Design.

Neil worked closely with Mark on the reshaping, acoustic modelling and design, and developed new and innovative solutions to the some very old problems associated with analogue sound reproduction.

John Loton - Bachelor of Engineering (Aeronautical)

John was instrumental in the "challenging process" where original "seed ideas" were subjected to an intense peer review process to ensure all design ideas were validated against known engineering principles.

Prof. Josef Tomas - Reshape Software and Mechanical Engineering Design.

Josef created the Reshape™ software that allowed us to create the Copperhead's unique shape, and move resonances inherent in all tonearms into regions where they could be controlled and effectively managed.

Dr. Glen Wolff - Advanced Systems Engineering.

Glen holds a PhD (Electrical Computer Engineering) and his expertise was sought to deal with the complex use of organic materials and their application on the Copperhead.

Rich O'Neil - Bachelor of Engineering (Mechanical)

Rich has been a welcome part of the development and testing of the Copperhead system.

We would also like to thank everyone involved in the manufacturing process, who's names and details can be found on our website - www.continuumaudiolabs.com