

EPsolar

eTracer series

— Network Maximum Power Point Tracking
Solar Charge Controller

OPERATION MANUAL

Models:
ET2415N ET3415N ET4415N ET6415N

Thank you very much for selecting our product!

This manual offers important information and suggestion about installation, use and troubleshooting, etc. Please read this manual carefully before using the product and pay attention to the safety recommendations in it.

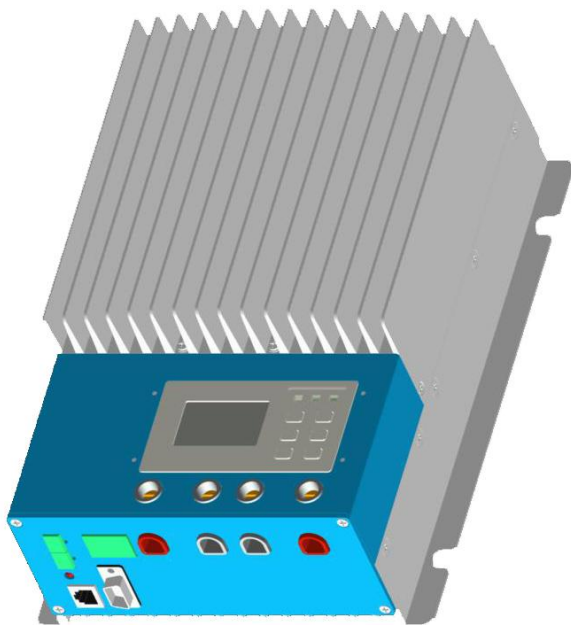

**Final interpretation right of the manual belongs to EPsolar.
Any changes without prior notice !**

Contents

1.0 Important Safety Information	1
2.0 General Information	2
2.1 Overview	2
2.2 Models & Parameters.....	3
2.3 Characteristics.....	4
2.4 Optional Accessories	6
3.0 Installation Instructions	7
3.1 General Installation Notes.....	7
3.2 Mounting	7
3.3 Wiring.....	9
4.0 Operation.....	13
4.1 MPPT Technology.....	13
4.2 Battery Charging Information.....	15
4.3 LED Indication	17
4.4 Display & Operation.....	17
5.0 Networking & communication	25
5.1 Introduction	25
5.2 Setting.....	26
5.3 Other Introductions	32
6.0 Protections, Troubleshooting & Maintenance	34
6.1 Protections	34
6.2 Troubleshooting.....	35
6.3 Maintenance.....	36
7.0 Warranty.....	38
8.0 Specifications	39
9.0 Conversion Efficiency Curves.....	42
10.0 Dimensions	45

1.0 Important Safety Information

This manual contains important safety, installation and operating instructions for eTracer. Save these instructions.

The following symbols are used throughout this manual to indicate potentially dangerous conditions or mark important safety instructions. please take care when meeting these symbols.



WARNING: Indicates a potentially dangerous condition.
Use extreme caution when performing this task.



CAUTION: Indicates a critical procedure for safe and proper operation of the controller.



NOTE: Indicates a procedure or function that is important for the safe and proper operation of the controller.

General Safety Information

- Read all of the instructions and cautions in the manual before installation.
- There are no user serviceable parts inside the controller. Do not disassemble or attempt to repair the controller.
- Mount the controller indoors. Prevent exposure to the elements and do not allow water to enter the controller.
- Please install controller in ventilated places, the temperature of heat sink may be quite high when working.
- Install external fuses/breakers as required.
- Disconnect the solar module and fuse/breakers near to battery before installing or adjusting the controller.
- Confirm that power connections are tightened to avoid excessive heating from loose connection.

2.0 General Information

2.1 Overview

Thank you for selecting the eTracer controller. With the features of industrial class product of high efficiency and reliability, the controller is a high-end product based on multiphase synchronous rectification technology. The features are listed below:

- 12V/24V/36V/48V auto work
- Excellent EMC design
- Thermal design and nature air cooling
- The first tracking to the maximum power point of solar modules less than 15 seconds, tracking efficiency Max. 99%
- Multiphase synchronous rectification technology ensures peak conversion efficiency up to 98%
- Multiphase power decentralized control make small power charging high effective, and improve the generated energy
- High speed and performance of the double processors architecture, improve the response speed and optimize the performance of the system
- Multiphase control technology, optimizes charging current smoothness, reduces ripple, and improves the system generating efficiency
- Humanized browser interface
- 128*64 dot-matrix LCD intuitively displays data and state, 6 buttons combinations for easy operation
- View up to 450 days data logging by connecting to Ethernet.
- Update controller software by connecting to PC
- RS232, CAN BUS and Ethernet 3 kinds of communication way to meet different occasions of demand
- Sealed, Gel and Flooded battery option
- Three stages of optimizing charging control
- Protection: over heat, over charging, PV short circuit and PV (battery) reversed

The controller features a built-in fuzzy control algorithm that maximizes the energy from the solar module(s) and charge the battery.

The controller charging process has been optimized for lengthening battery life and improved system performance. The comprehensive self-diagnostics and electronic protection functions can prevent damage from installation mistakes or system faults.

Although the controller is very simple to configure and use, please take your time to read the operation's manual. This will help you make full use of all the functions and improve your PV system.

2.2 Models & Parameters

Standard RS232, CAN BUS and ETHERNET communication interface

12V/24V/36V/48V system voltage auto work*

Max. PV input voltage DC150V**

	Rated charging current	Max. PV input power
ET2415N	20A	1040W
ET3415N	30A	1600W
ET4415N	45A	2400W
ET6415N	60A	3200W

* Every time start up the controller, system voltage automatically identified, do not need your any operation or setting.

** Array voltage should never exceed maximum PV input voltage. Refer to the solar module documentation to determine the highest expected array Voc (open circuit voltage) as defined by the lowest expected ambient temperature for the system location.

2.3 Characteristics

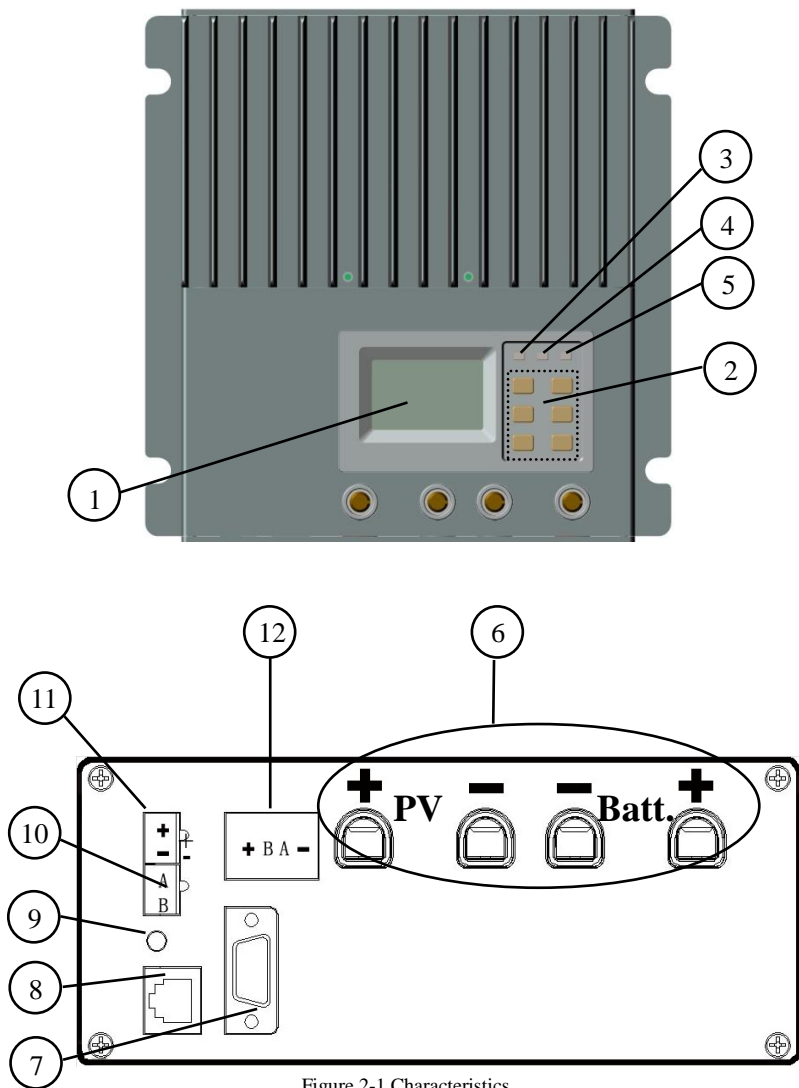

Figure 2-1 Characteristics

1 –LCD

Display interface, 128x64 dot-matrixes

2 –Buttons

Browse or modify all parameters.

3 – Battery Indicator

An LED indicator shows battery status.

4 – Charging Indicator

An LED indicator shows charging or not.

5 – Faults Indicator

An LED indicator shows controller faults.

6 –Terminal

Refer to Figure 2-2

7 – Serial RS-232 Port (DB9)

Monitor controller by PC or update controller software.

8 – Ethernet Port (RJ45)

Connect Ethernet, monitor controller remotely by network.

9 – Solar polarity reversed Indicator

An LED indicator shows solar modules positive and negative reversed.

10 – Remote Temperature Sensor Port (MC1.5-3.81-2L)

Connect RTS, Measure battery temperature to make temperature compensation.

11 – Remote Battery Voltage Sensor Port (MC1.5-3.81-2L)

Connect RBVS, measure battery voltage accurately.

12 – CAN BUS Port (MC1.5-3.81-4L)

Communicate with other CAN BUS devices made by EPSolar.

2.4 Optional Accessories

Remote Temperature Sensor (Model: RTS300RA)

Acquiring of battery temperature for undertaking temperature compensation of control parameters, the standard length of the cable is 2m (can be customized if want longer).

The **RTS300RA** connects to the **MC1.5-3.81-2L** port (10th) on the controller.

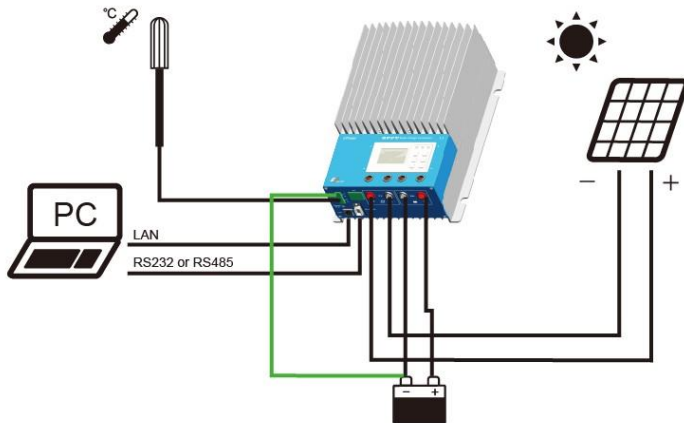

Figure2-2 Wiring diagram

Remote Battery Voltage Sensor Port (MC1.5-3.81-2L)

Detect the battery voltage exactly, the standard length of the cable is 2m (can be customized if want longer). The **RBVS200VA** connects to the **MC1.5-3.81-2L** port

(11th) on the controller.

3.0 Installation Instructions

3.1 General Installation Notes

- Read through the entire installation section first before installation.
- Be very careful when working with batteries. Wear eye protection. Have fresh water available to wash and clean any contact with battery acid.
- Uses insulated tools and avoid placing metal objects near the batteries.
- Explosive battery gasses may be present during charging. Be certain there is sufficient ventilation to release the gasses.
- Avoid direct sunlight and do not install in locations where water can enter the controller.
- Loose power connections and/or corroded wires may result in resistive connections that melt wire insulation, burn surrounding materials, or even cause fire. Ensure tight connections and use cable clamps to secure cables and prevent them from swaying in mobile applications.
- Use with Gel, Sealed or Flooded batteries only.
- Battery connection may be wired to one battery or a bank of batteries. The following instructions refer to a singular battery, but it is implied that the battery connection can be made to either one battery or a group of batteries in a battery bank.
- Multiple same models of controllers can be installed in parallel on the same battery bank to achieve higher charging current. Each controller must have its own solar module(s).
- Select the system cables according to $3A/mm^2$ or less current density.

3.2 Mounting



NOTE: When mounting the eTracer, ensure free air through the controller heat sink fins. There should be at least 150mm of clearance above and below the controller to allow for cooling. If mounted in an

enclosure, ventilation is highly recommended.



WARNING: Risk of explosion! Never install the eTracer in a sealed enclosure with flooded batteries! Do not install in a confined area where battery gas can accumulate.

Step 1: Choose Mounting Location

Locate the eTracer on a vertical surface protected from direct sun, high temperature, and water.

Step 2: Check for Clearance

Place the eTracer in the location where it will be mounted. Verify that there is sufficient room to run wires and that there is sufficient room above and below the controller for air flow.

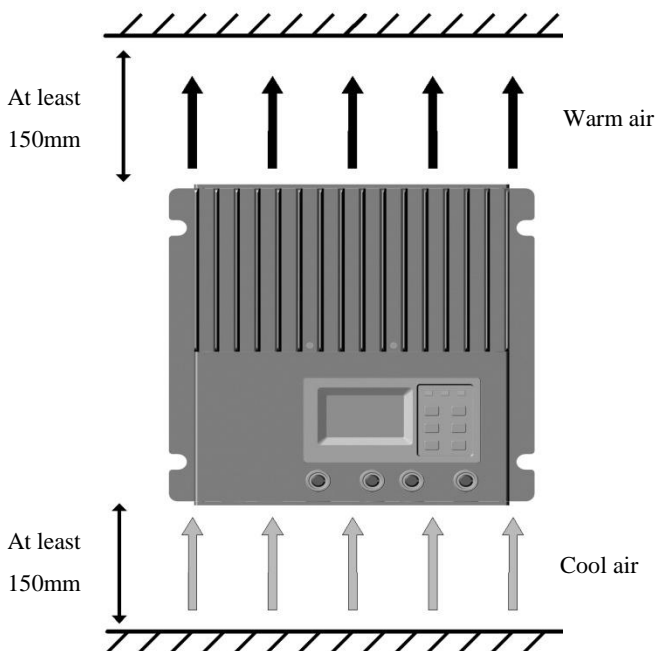

Figure 3-1 Mounting and cooling

Step 3: Mark Holes

Mark the four (4) mounting hole locations on the mounting surface.

Step 4: Drill Holes

Remove the controller and drill four sizeable holes in the marked locations.

Step 5: Secure Controller

Place the controller on the surface and align the mounting holes with the drilled holes in step 4. Secure the controller in place using the mounting screws.

3.3 Wiring



NOTE: A recommended connection order has been provided for maximum safety during installation.



NOTE: Do not entangle all wiring together, communication cable and power wires should be as far away as possible, to prevent interfering communication signal transmission.



NOTE: The eTracer is a negative ground controller. Any negative connection of solar or battery can be earth grounded as required. Grounding is recommended.



CAUTION: For mobile applications, be sure to secure all wiring. Use cable clamps to prevent cables from swaying when the vehicle is in motion. Unsecured cables create loose and resistive connections which may lead to excessive heating and/or fire.

Step 1: Remote Temperature Sensor Connection



NOTE: The controller will not perform temperature compensation for charging parameters if the RTS300RA is not used.



CAUTION: Equipment Damage! Never place the temperature sensor inside a battery. Both the RTS300RA and the battery will be damaged.

The included remote temperature sensor RTS300RA is recommended for effective temperature compensated charging. Connect the RTS300RA to the 10th port (MC1.5-3.81-2L) on the controller (see figure 2-1). There is no polarity, so either wire (+ or -) can be connected to either screw terminal. No damage will occur if connect the RTS300RA to the remote battery voltage sense port, but the connection will not be recognized.

Step 2: Remote Battery Voltage Sensor Connection



NOTE: When connecting, please pay attention to ‘+’ and ‘-’



CAUTION: Be careful when installation. Please never plug the voltage sensor wires into to the RTS300RA terminals (10th Port) It will cause an alarm or damage the controller.

The voltage at the battery terminals on the controller may differ slightly from the real battery voltage due to connection and cable resistance. The remote battery voltage sensor will enable the controller to detect the battery voltage more exactly and avoid voltage tolerance. Connect the remote battery voltage sensor wires to the 11th port (MC1.5-3.81-2L) on the controller (see figure 2-1). A battery voltage sensor connection is not required to operate the controller, but it is recommended for best performance.

The voltage sensor wires should be cut to the length as required. The wire size can range from 0.25 to 1.0 mm² (24 to 16 AWG). And maximum length is 3m. A twisted pair cable is recommended but not required.

Please be careful to ‘+’ and ‘-’ when connecting. No damage will occur if the polarity is reversed, but the controller can’t read a reversed sensor voltage.

Step 3: Network Connection

.....



WARNING: Shock Hazard! The network cables and the power conductors must be as far away as possible.

There are three kinds of communication: RS-232, CAN BUS and Ethernet. Please use matching communication cables and make sure the cables are connected firmly during data transmits

- **RS-232 Connection:**

The serial RS-232 port is a standard 9-pin (DB9) male connector. Refer to 9th port on the controller in the figure 2-1.

- **CAN BUS Connection:**

The Can BUS port is a standard **MC1.5-3.81-4L** connector. Refer to 12th port on the controller in the figure 2-1.

- **Ethernet Connection:**

The Ethernet port is a standard RJ-45 connector. Refer to 8th port on the controller in the figure 2-1.

Step 4: Power Connection



WARNING: Risk of electric shock! Use fuses or breakers in solar and battery circuits is recommended, and make them keep OFF state before connection.



WARNING: Risk of electric shock! Exercise caution when handling solar wiring. The solar module(s) high voltage output can cause severe shock or injury. Pay more attention for it.



WARNING: Risk of explosion or fire! Never short circuit battery positive (+) and negative (-) or cables.

- **Battery Connection:**

Connecting a fuse in series in the battery circuit, and the battery circuit fuse must be 1.25 to 2 times of the rated current. Make it keep OFF state before connection.

Connect battery positive (+) and negative (-) to battery terminals on the controller in the figure 2-1. Please pay much attention to ‘+’ and ‘-’

- **Solar Module(s) Connection:**

Connecting a breaker in series in the solar circuit is recommended, and the breaker must be 1.25 to 2 times of the rated current. Make it keep OFF state before connection. Connect solar positive (+) and negative (-) to battery terminals on the controller in the figure 2-1. Please pay much attention to ‘+’ and ‘-’

Step 5: Power-Up

- Confirm that all connections are correct especially the Solar and Battery polarities.
- Turn the battery fuse on first. Confirm battery power-up correct (refer to section 4.0)
- Note that a battery must be connected to the eTracer to start and operate the controller. The controller will not operate only from solar input.
- Turn the solar breaker on. If the solar module(s) is in full sunlight, the controller will begin charging.
- If the battery LED error exists or LCD interface alarms, please refer to section 6.0 for troubleshooting.

4.0 Operation

4.1 MPPT Technology

The eTracer utilizes Maximum Power Point Tracking technology to extract maximum power from the solar module(s). The tracking algorithm is fully automatic and does not require user adjustment. eTracer technology will track the array *maximum power point voltage* (V_{mp}) as it varies with weather conditions, ensuring that maximum power is harvested from the array through the course of the day.

• Current Boost

In many cases, eTracer MPPT technology will ‘boost’ the solar charge current. For example, a system may have 8 Amps of solar current flowing into the eTracer and 10 Amps of charge current flowing out to the battery. The eTracer does not create current! Rest assured that the power into the eTracer is the same as the power out of the eTracer. Since power is the product of voltage and current (Volts \times Amps), the following is true*:

(1) Power Into the eTracer = Power Out of the eTracer

(2) Volts In \times Amps In = Volts Out \times Amps Out

* Assuming 100% efficiency. Actually, the losses in wiring and conversion exist.

If the solar module’s V_{mp} is greater than the battery voltage, it follows that the battery current must be proportionally greater than the solar input current so that input and output power are balanced. The greater the difference between the maximum power voltage and battery voltage, the greater the current boost. Current boost can be substantial in systems where the solar array is of a higher nominal voltage than the battery.

• An Advantage Over Traditional Controllers

Traditional controllers connect the solar module directly to the battery when recharging. This requires that the solar module operate in a voltage range that is below

the module's V_{mp} . In a 12V system for example, the battery voltage may range from 11-15Vdc but the module's V_{mp} is typically around 16 or 17V.

Figure 4-1 shows a typical current VS. voltage output curve for a nominal 12V off-grid module.

Current VS. Voltage in 12V system

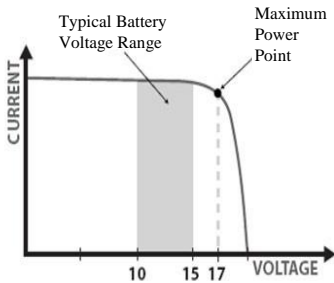

Output power in 12V system

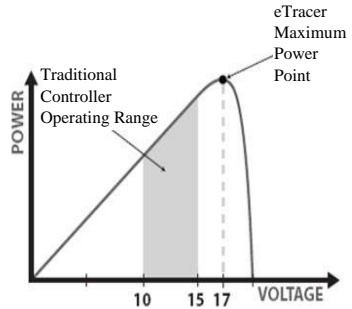

Figure 4-1 Nominal 12V solar module I-V curve and output power graph

The array V_{mp} is the voltage where the product of current and voltage (Amps \times Volts) is greatest, which falls on the 'knee' of the solar module I-V curve as shown in Figure 4-1. Because Traditional controllers do not operate at the V_{mp} of the solar modules(s), energy is wasted that could otherwise be used to charge the battery and power system loads. The greater the difference between battery voltage and the V_{mp} of the module, the more energy is wasted.

eTracer MPPT technology will always operate at the V_{mp} resulting in less wasted energy compared to traditional controllers.

• Conditions That Limits the Effectiveness of MPPT

The V_{mp} of a solar module decreases as the temperature of the module increases. In very hot weather, the V_{mp} may be close or even less than battery voltage. In this situation, there will be very little or no MPPT gain compared to traditional controllers. However, systems with modules of higher nominal voltage than the battery bank will always have an array V_{mp} greater than battery voltage. Additionally, the savings in wiring due to reduced solar current make MPPT worthwhile even in hot climates.

4.2 Battery Charging Information

The eTracer has a 3 stages battery charging algorithm for rapid, efficient, and safe battery charging.

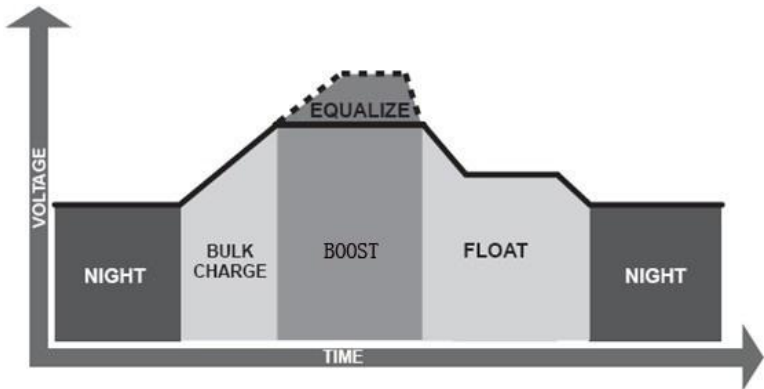

Figure 4-2 eTracer charging algorithm

- **Bulk Charge**

In this stage, the battery voltage has not yet reached boost voltage and 100% of available solar power is used to recharge the battery.

- **Boost Charge**

When the battery has recharged to the Boost voltage setpoint, constant-voltage regulation is used to prevent heating and excessive battery gassing. The Boost stage remains for some time and then goes to Float Charge. Every time when the controller is powered on, if it detects neither over discharged nor overvoltage, the charging will enter into boost charging stage.

- **Float Charge**

After the Boost voltage stage, Tracer will reduce the battery voltage to float voltage setpoint. When the battery is fully recharged, there will be no more chemical reactions and all the charge current transmits into heat and gas at this time. Then the eTracer

reduces the voltage to the floating stage, charging with a smaller voltage and current. It will reduce the temperature of battery and prevent the gassing, also charging the battery slightly at the same time. The purpose of Float stage is to offset the power consumption caused by self consumption and small loads in the whole system, while maintaining full battery storage capacity.

In Float stage, loads can continue to draw power from the battery. In the event that the system load(s) exceed the solar charge current, the controller will no longer be able to maintain the battery at the Float setpoint. Should the battery voltage remains below the boost reconnect charging voltage, the controller will exit Float stage and return to Bulk charging.

- **Equalize**



WARNING: Risk of explosion!

Equalizing flooded battery would produce explosive gases, so well ventilation of battery box is necessary.



NOTE: Equipment damage!

Equalization may increase battery voltage to the level damaging to sensitive DC loads. Ensure that all load allowable input voltages are greater than the equalizing charging set point voltage.



NOTE: Equipment damage!



Over-charging and excessive gas precipitation may damage the battery plates and activate material shedding on them. Too high an equalizing charge or for too long may cause damage. Please carefully review the specific requirements of the battery used in the system.

Certain types of batteries benefit from periodic equalizing charge, which can stir the electrolyte, balance battery voltage and complete chemical reaction. Equalizing charge increases the battery voltage, higher than the standard complement voltage, which gasifies the battery electrolyte.

The controller will equalize the battery on 28th each month. The constant equalization period is 60~180 minutes. If the equalization isn't accomplished in one-time, the equalization recharge time will be accumulated until the set time is finished. Equalize charge and boost charge are not carried out constantly in a full charge process to avoid too much gas precipitation or overheating of battery.

4.3 LED Indication

Table 4.3.1 LED indication







Icon	Indicator	Indication	Status
	Charging LED	Green ON	Charging
		Green OFF	No Charging
	Battery LED	Green ON	Normal
		Orange ON	UVW
		Red ON	LVD
		Red Blink	OVD
	Fault LED	Red OFF	Normal
		Red Blink	Current Err
			Over Charging Current
			PV OVD
			Over Temp

For the abbreviation explanations, please refer to annex 1



4.4 Display & Operation

Buttons explanation

There's 2 kind mode display -- Browse & Setting, and 6 buttons--

      , they have different means in each mode.

Browse mode:

1.   Page up/down or move cursor among menus

2. **OK** Enter menu or setting mode
3. **ESC** Return to main menu in any interface.
4. **ESC** + **+** Recover default password.

Setting mode:

1. **↑** **↓** Move cursor.
2. **+** **-** Modify value or option
3. **OK** Save the changes and return to 'Browse mode'.
4. **ESC** Return to 'Browse mode' without saving the change.

Note: Password is a must necessary for modifying parameters at any time. So saving all the changes in one group in one time is highly recommended.

Initialization



When the controller is powered on, the LCD displays the information as shown in the picture. It indicates that initialization is normal when the interface goes automatically to the monitoring interface.

Main Menu

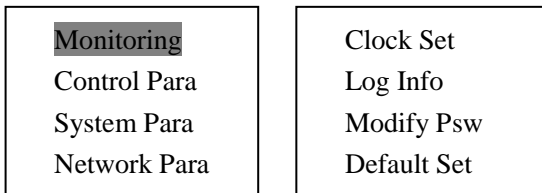

Figure 4.4.1 main menu

Press **↑** **↓** button to moves inverse cursor among 8 menus.

Press **OK** to enter corresponding interface.

➤ **Monitoring interface**

There are 7 interfaces for monitoring, as shown in the picture.

Click **↑** **↓** button to change interface in turn.

Click **ESC** button to return main menu in any monitoring interface.

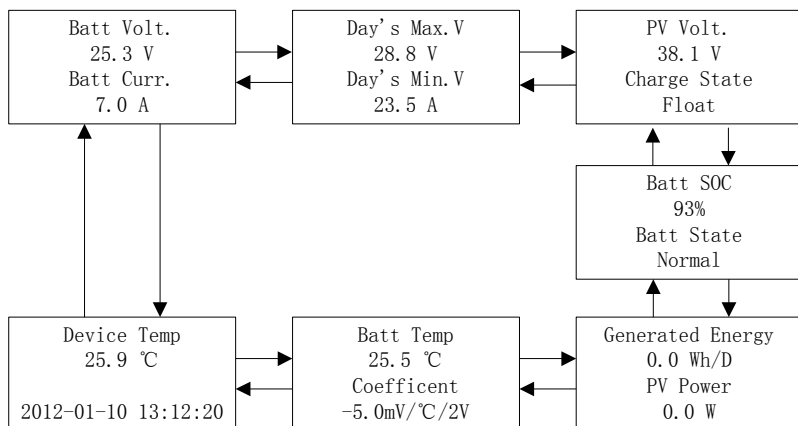

Figure 4.4.2 Monitor interface

Notes:

1. 'Batt Temp' will display '25.0°C' when there's no remote temperature sensor.
2. There's no temperature compensation when 'Coefficient = 0.0mV/°C/2V'
3. State :

Batt. State	Normal, UVW, LVD, OVD
Charge State	No-charge, Equalize, Boost, Float

For the Abbreviation Explanations, please refer to Annex 1

4. The parameters in monitoring interface are only for browse.

➤ Control Para

There's 9 interfaces for 'Control Parameters', as shown in the Figure 4.4.3. And display 2 kinds of mode-- Browse & Setting mode. In setting mode, all the parameters can be modified. And will immediately effect when saved.

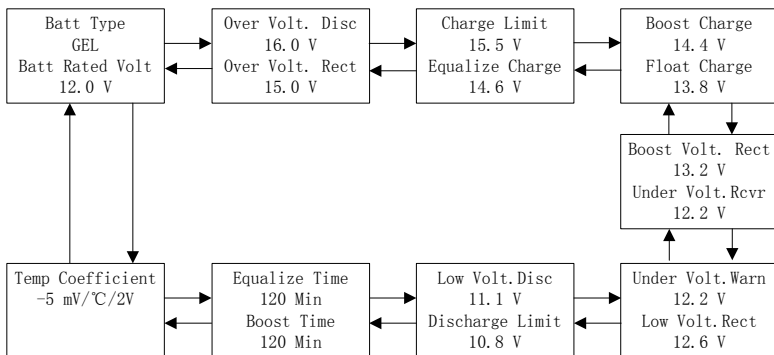

Figure 4.4.3 Control parameters interface

For parameter range, please refer to the **Table 8.1**

For the Abbreviation explanations, please refer to **Annex 1!**

➤ System Para

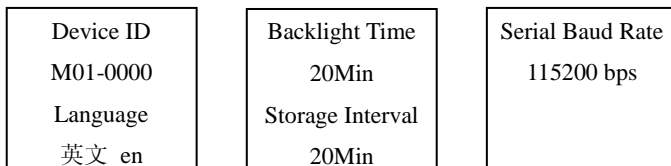

Figure 4.4.4 System parameters

Table 4.4.2: System parameter

	Item	Default	Option & Range
1	Device ID	M01-0000	0000~9999, use to differentiate the data belong to which device
2	Language	英文 en	‘英文 en’, ‘中文 cn’
3	Backlight Time	20 Min	1~30 Minutes, ‘--’ means always ON
4	Storage Interval	20 Min	1~30 Minutes,
5	Serial Baud Rate	115200	115200 bps, 9600 bps

➤ Network Para

Network Type Static Network Psw 000000	Network Port 0080 MAC Add. 000000000000
IP Add. 192.168.000.002 Subnet Mask 255.255.255.000	Default Gateway 192.168.000.001

Figure 4.4.5 Network parameters

Table 4.4.3: Network parameters

	Item	Default	Option & Range
1	Network Type	static	‘static’: user setting IP ‘DHCP’: Auto get IP
2	Network Psw	000000	000000~999999, used to login Web monitoring page
3	Network Port	0080	Refer user’s network

4	MAC Add.	ede025125328	Refer user's network
5	IP Add.	192.168.000.002	Refer user's network
6	Subnet Mask	255.255.255.000	Refer user's network
7	Default Gateway	192.168.000.001	Refer user's network

Note: In the same network, MAC address must be unique to each controller. Otherwise communication error will occur.

➤ Clock Set

Clock Set

2012Y-03M-05D

13H: 45M: 58S

In this interface, click **OK** enter into 'Set mode', user can adjust real-time date & time by buttons **↑** **↓** **+** **-**.

➤ Log Info

Alarm Log Query

From 2012Y01M03D

To 2012Y02M20D

Total: 00073

Figure log 1

NO. 00001/00073

Batt UVW /Start

2012-01-10 14:32

Para 11.8V

Figure log 2

There's two ways to browse the event log.

- In 'Log 1' interface, click **↓** button, jump to the browse interface, then use **↑** **↓** to page up or down. And **ESC** back to 'Log 1' interface.
- In 'Log 1' interface :
 Press **OK** to enter setting mode
 Set start-time /end-time.
 Press **OK** back to 'browse mode'
 Press **↑** **↓** to page up or down
 Press **ESC** back to 'Log 1' interface.

Notes:

1. 'From' time must be ahead of 'To' time, or else, there will be 'Para Error' pop out.
2. Browse interface includes: warning event sequence number, warning event, start or end time, parameter value. (Refer to log 2)
3. For Event explanations, please refer to **Annex1!**

➤ Password

Psw (Password) is used for protecting all parameters that can be modified. Before entering setting mode, Psw 2 will pop up. Input right password, otherwise Psw 3 – PSW Error will popup.

Modify Psw Old Psw 000000 New Psw 000000 New Psw 000000
--

Psw 1

Input Psw 000000

Psw 2

Tip Message PSW Error

Psw 3

Tip Message Modify Fail

Psw 4

Modify password

In 'Modify Password' interface, press **OK** to enter setting mode, input old and new password. Neither of them is wrong, Psw 4 Modify Fail will popup.

Recover default Password

Psw Default?

Press **ESC** and **+** simultaneously in any interface, Display this interface. Press **OK** to recover default password, or press **ESC** to remain current password.

Notes:

1. Please remember the password. The default is '000000'.
2. Tip Message will popup only when input wrong. If right, there will be no tip.

➤ Default Set

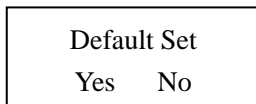

In this interface, user can restore default parameters.

Click **OK** to enter setting mode', use **↑** **↓** to moving cursor, if select 'Yes', and press **OK**, all

parameters will be recovered to default, and saved. The interface will restore to 'Browse mode'. If select 'No', remain current parameters.

Note: The password will not be changed in this default set. Please refer to Password introduce.

Prompt Message

In any interface, Prompt Message will popup once warning event occurs as below: OVD, UVW, LVD, Current Err, Over Current, Over Temp or PV OVD, press any key to quit. Inspecting it carefully is recommended in case that some potential hazard occurs.

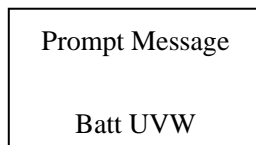

In setting mode, if click **OK**, 'Modify OK' will popup, it will disappear and return back to 'Browse mode' after one second, else click **ESC** to 'Browse mode' without Prompt Message' popup.

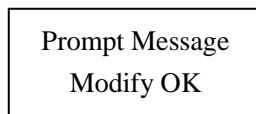

For the Event explanations, please refer to **Annex 1!**

5.0 Networking & communication

5.1 Introduction



Note: Windows XP /windows 7 are recommended!

IE7.0 or above is recommended!

Can't compatible with the safari browser of Mac OS X!

CAUTION: Risk of Tampering!



The eTracer doesn't feature built-in network security. It is the responsibility of the user or network administrator to install the eTracer behind a network firewall to prevent unauthorized access.

The Ethernet port supports HTTP, TCP/IP protocols to provide a fully web-enabled interface between the eTracer and a LAN network. Features the Ethernet connection provides include:

- Monitor the controller from a web browser
- Modify controller settings from a web browser

This section provides a summary of each of the features. For detailed information about Ethernet connectivity and networking, please refer to our website at:

<http://www.epsolarpv.com/>

Network Information

Connect the controller directly to a PC using an Ethernet cross-over cable, or using standard cable to exchanger. Use CAT-5 or CAT-5e twisted pair Ethernet cables with RJ-45 connectors.

Factory default network Settings refer to Table 4.4.3.

2 LED's on the Ethernet jack indicate link and activity status.

Condition	Green LED	Yellow LED
Network connection OK	ON	OFF
Network activity	ON	Blinking
Error	OFF	ON

Web pages

Connect the eTracer controller to the network. Open a web browser on any PC on the network. Enter the IP address of the controller ('192.168.0.2' by default) in the address bar of the web browser. The login webpage will load. Links are provided to Real Time Data, Ctr Para Set, Net Para Set, Log Query, Password, and Help Document pages. Pages served by the controller are ideal for retrieving quick information about the charge controller and making adjustments to network settings. However, there is no ability to customize the layout or data displayed. Also, information from multiple controllers cannot be displayed on the same webpage.

5.2 Setting

Set the controller IP address, corresponding subnet mask and default gateway and connect to network. Enter IP address of equipment at the address bar of browser and then the equipment can be monitored.

Web monitoring mainly includes such functions as user login, real-time data, control parameters setting, network parameters setting, log query and password modification, etc.

1) User login

Not all users that are connected into Internet/Intranet can browse those data in the system. Generally password should be input so as to ensure safety of the system.

Enter network password and press the button '**Login**', and if it is right, it will display monitoring page; otherwise, it will prompt '**Password Error**'.

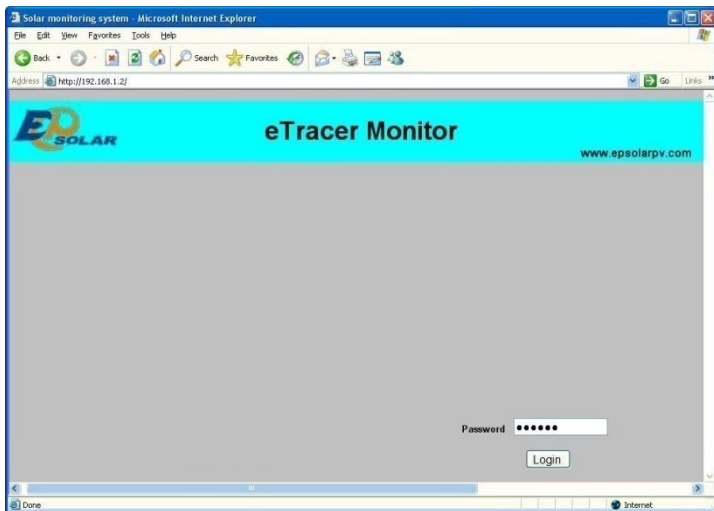

2) Real Time Data

Click 'Real Time Data' on the left side to view real-time operating parameters.

Real Time Data			
Batt.Voltage(V):	13.4	Batt.State:	Normal
PV Voltage(V):	0.0	Charge State:	No Charge
Batt.Current(A):	0.0	SOC(%):	72
Charge Power(W):	0	Remote Sensor Temp.(°C):	25.0
Energy Gen.(kWh):	0.0	Local Sensor Temp.(°C):	8.5
Max.Batt.Voltage(V):	13.5		
Min.Batt.Voltage(V):	13.4		

3) Ctr Para Set

Click 'Ctr Para Set' on the left side to enter Control Parameter Set page and the system will display the current control parameter configuration. Users can also modify control parameters. After users modify control parameters and click 'Submit', if it is successfully adjusted, 'Save Success' will pop out; otherwise, 'Illegal para' will appear. Click 'Default', control parameters will recover to default values in line with current system voltage.

Notes: 'Batt Rate Voltage' as battery rated voltage is displayed according to the real system value, it is not changeable. If parameter modified in the period is not up to the standard range, dialogue box 'Illegal para' will pop out and at the same time, the parameter will change to the previous value.

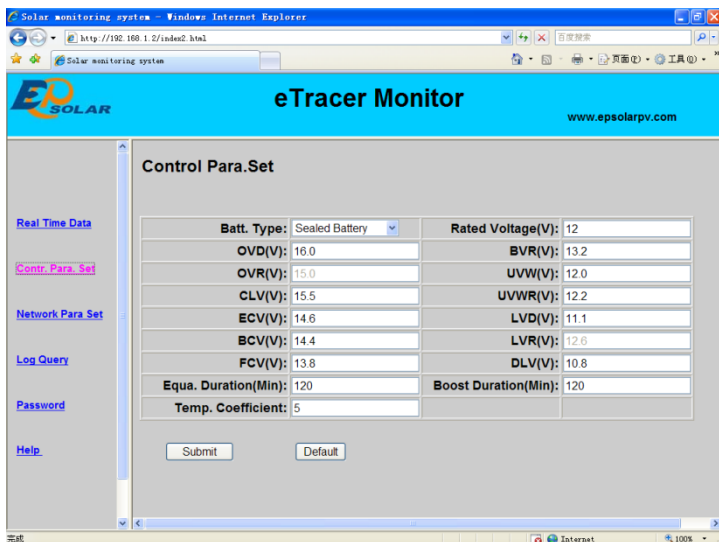

4) Net Para Set

Click 'Net Para Set' on the left side to enter Network Parameter Set page and the system will display the current network parameter configuration. After users modify control parameter and click 'Submit', if it is successfully adjusted, 'Save Success' will pop out; otherwise, 'Illegal para' will appear.

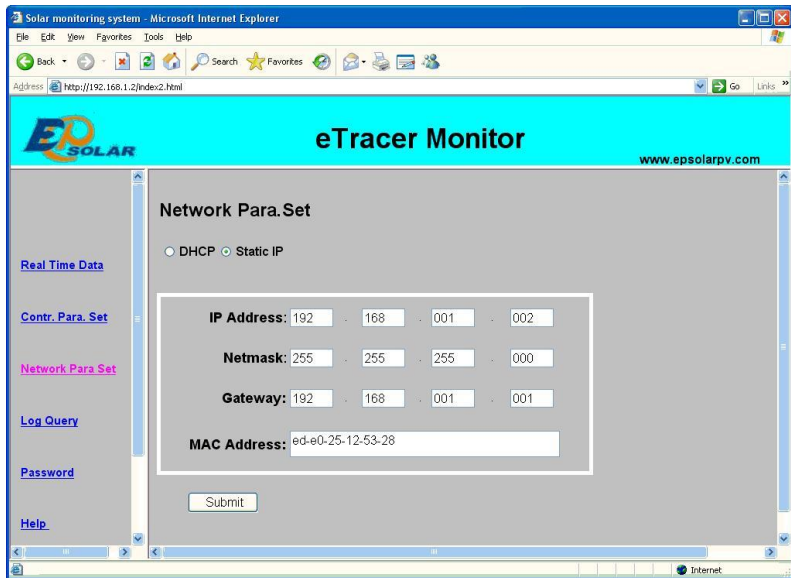

5) Log Query

Click 'Log Query' on the left side to enter Log Query page. Users can choose 'Data Log' or 'Event Log', and after click 'Submit', the system will display all current record page by page.

The controller can record max. 21000 PCS data log and 58000 PCS event log. The storage interval is 10 ~30 mins. The operation data shows as below:

Solar monitoring system - Windows Internet Explorer
 http://192.168.1.2/index.html
 Solar monitoring system
 www.epsolarpv.com

eTracer Monitor

Log Query

Data Log

Date	Batt. Voltage (V)	PV Voltage (V)	Batt. Current (A)	Charge Power (W)	Energy Gen. (kWh)	RS Temp. (°C)	Local Temp. (°C)	SOC (%)	Batt. State	Charge State
2012-01-01 12-20-00	13.0	0.0	0.0	0	0.0	25.0	20.1	58	Normal	No Charge
2012-01-03 12-46-00	13.6	0.0	0.0	0	0.0	25.0	20.3	76	Normal	No Charge
2012-01-03 13-06-00	13.6	0.0	0.0	0	0.0	25.0	20.3	76	Normal	No Charge
2012-01-03 13-26-00	13.6	0.0	0.0	0	0.0	25.0	20.9	76	Normal	No Charge
2012-01-03 13-46-00	13.6	0.0	0.0	0	0.0	25.0	20.8	76	Normal	No Charge
2012-01-03 14-06-00	13.6	0.0	0.0	0	0.0	25.0	20.4	76	Normal	No Charge
2012-01-03 14-26-00	13.6	0.0	0.0	0	0.0	25.0	20.7	76	Normal	No Charge

Page NO 1/8 Input Page NO

完成 Internet 100%

Solar monitoring system - Windows Internet Explorer
 http://192.168.1.2/index.html
 Solar monitoring system
 www.epsolarpv.com

eTracer Monitor

Log Query

Event Log

Date	Event Des	State	Parameter
2012-01-01 12-21-06	Batt OVD	Start	17.0
2012-01-01 12-21-18	Batt OVD	Over	12.0
2012-01-01 12-24-12	Batt UVW	Start	11.6
2012-01-01 12-24-18	Batt UVW	Over	12.5
2012-01-02 12-24-34	Batt UVW	Start	11.4
2012-01-02 12-24-43	Batt LVD	Start	10.4
2012-01-02 12-24-49	Batt UVW	Over	12.8

Page NO 1/5 Input Page NO

Internet 100%

6) Password

Click 'Password' on the left side to enter password modification page. After enter the current and new passwords, the system will judge if the old password is right and if the new passwords entered twice is the same. If it is right, the system will present 'Save Success', otherwise, 'Password Error' will appear.

Notes: The input only supports numbers 0-9.

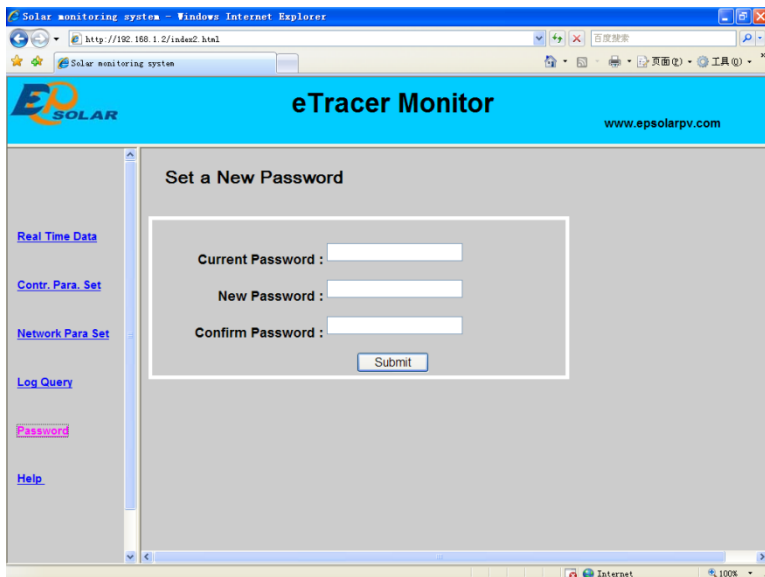

6) Help

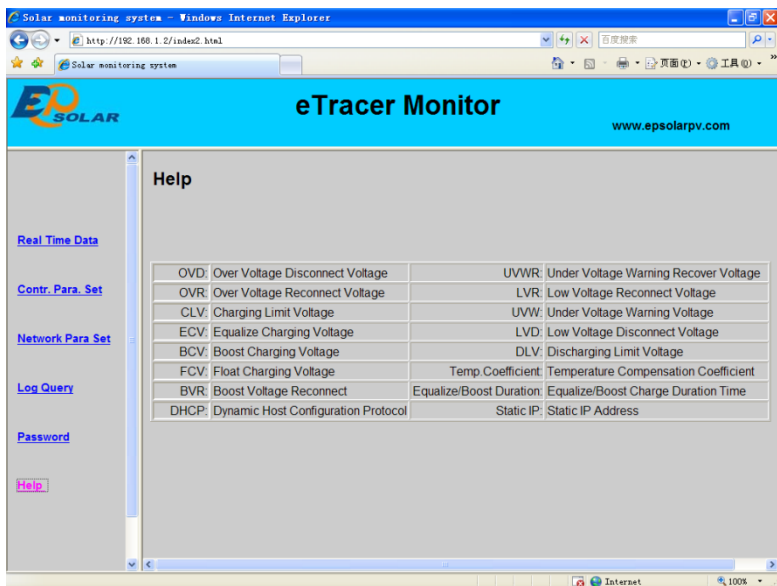

5.3 Other Introductions

1. CAN

.....
 CAN bus protocol is used to connect remote meter or controller.

2. RS-232

.....
 RS-232 port can be connected to PC with a cross-over serial cable, use to update controller software. Download the latest controller firmware from our home page and update it.

3. Update

.....
 Download program file from :<http://www.epsolarpv.com/download/>

Turn off controller at first and update as follows:

Step1. Connect the controller to PC serial port using cross-over serial cable.

Step2. Run the software ***CLM3SProgrammer.exe*** that downloaded from <http://www.epsolarpv.com/en/index.php/Technical/download.>

Step3. Click 'Browse' and choose the file Display-Verx.x.lof or Charge-Verx.x.lof. On 'File Description' bar, the basic information about the chosen file will be displayed.

When update both, there is no particular order.

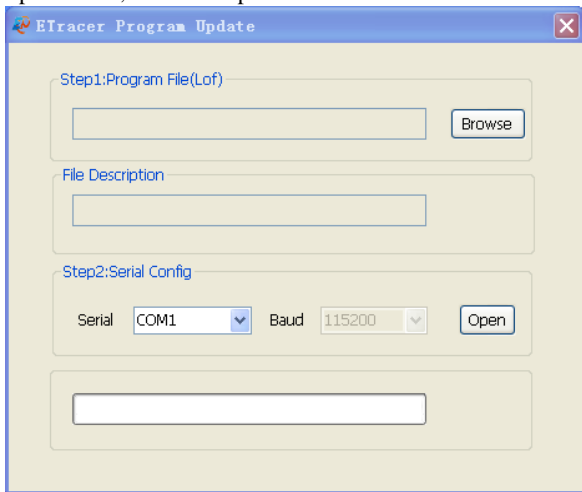

Step4. Choose the PC communication serial that connect to the controller. Default 'Baud' is 115200bps.

Step5. Click the button 'Open'.

Step6. Power-on the controller. Updating progress will start and the progress bar displays the percentage. When the progress bar come to end, there will display 'Program Update Finished', then disconnect the controller from PC and power off.

Step7. Restart the controller after updating.

Notes: In the period of updating, if power down or disconnected, it will prompt 'Connect time out', redo above step.

6.0 Protections, Troubleshooting & Maintenance

6.1 Protections

•PV Short Circuit

When PV short circuit occurs, the controller will stop charging. Clear it to resume normal operation. PV input must not exceed 100V, otherwise the controller will be damaged.

•PV Over current

When charging current is much more than rating, the controller will disconnect solar module(s). So eTracer may not work in the maximum power point if PV current doesn't match with the current rating.

•PV Overvoltage

If PV voltage is larger than maximum input open voltage 150V, PV will remain disconnected and warn until the voltage falls safely below 145V. PV voltage cannot be too high, otherwise it may damage the controller.

•PV Polarity Reversed

Fully protection against PV reverse polarity, no damage to the controller will result. Correct the miswire to resume normal operation.

•Battery Polarity Reversed

Fully protection against battery reverse polarity, no damage to the controller will result. Correct the miswire to resume normal operation.

•Overheating Protection

If the temperature of the controller heat sinks exceeds 85°C, the controller will automatically start the overheating protection.

6.2 Troubleshooting

- ◇ Charging LED indicator off during daytime when sunshine falls on solar modules properly.

Probable Cause: Solar modules disconnected.

Solution: Confirm that PV and battery wire connections are correct and tight.

.....

- ◇ Battery LED indicator red flashing, LCD displaying 'OVD'.

Probable Cause: Battery voltage is larger than over voltage disconnect voltage (OVD).

Solution: Check if battery voltage too high, and disconnect solar modules.

.....

- ◇ Fault LED indicator flashing, LCD displaying 'Current Err'.

Probable Cause: Charging current in three phases is unbalanced.

Solution: Disconnect solar modules and restart the eTracer; if the fault still exists, please contact the supplier to make maintenance.

.....

- ◇ Fault LED indicator flashing, LCD displaying 'Over Current'.

Probable Cause: Charging current is much more than the rating.

Solution: Please check whether solar modules match with nominal parameter of the controller. When charging current reaches 1.05~1.2 times of the rating, eTracer will automatically adjust charging current to the rating or below but not stop; when charging current reaches 1.2 times much more than nominal value, eTracer will automatically stop charging in 5 seconds and automatically circularly activated so as to reconnect charging. There is 5 times limit for reconnecting. The delay for each reconnecting is 1min, 2 mins, 3mins, 4mins, 5mins corresponding.

.....

- ◇ Fault LED indicator flashing, LCD displaying 'Over Temp'.

Probable Cause: Heat sinks operational temperature is quite high to 85°C or above.

Solution: The controller will automatically stop working. When the temperature is below 75°C, the controller will resume to work.



Cannot connect to the controller via RS-232.

Probable Cause: RS-232 serial baud rate setting error or serial-USB adapter incorrect configuration.

Solution: Check the following: 1.The RS-232 cable is straight-through, not a Null Modem (cross-over); 2.Whether the selected RS-232 serial baud rate is suited for your device; 3.If using a serial-USB adapter, verify that the adapter software is installed and a serial COM port has been mapped. Check the activity light on the USB adapter if there is. If there is no activity, the wrong COM port has been chosen or there is a configuration issue with the adapter.

6.3 Maintenance

The following inspections and maintenance tasks are recommended at least two times per year for best controller performance.

- Check that the controller is securely mounted in a clean and dry environment.
- Check that the air flow and ventilation around the controller is not blocked. Clear all dirt or fragments on the heat sink.
- Check all the naked wires to make sure insulation is not damaged for serious solarization, frictional wear, dryness, insects or rats etc. Maintain or replace the wires if necessary.
- Tighten all the terminals. Inspect for loose, broken, or burnt wire connections.
- Check and confirm that LED or LCD is consistent with required. Pay attention to any troubleshooting or error indication .Take necessary corrective action.
- Confirm that all the system components are ground connected tightly and correctly.
- Confirm that all the terminals have no corrosion, insulation damaged, high temperature or burnt/discolored sign, tighten terminal screws to the suggested torque.
- Inspect for dirt, insects and corrosion, and clear up.
- Check and confirm that lightning arrester is in good condition. Replace a new one in time to avoid damaging of the controller and even other equipments.



Warning: Risk of electric shock!

Make sure that all the power is turned off before above operations, and then follow the corresponding inspections and operations.

7.0 Warranty

The eTracer charge controller is warranted to be free from defects for a period of TWO (2) years from the date of shipment to the original end user. We will, at its option, repair or replace any such defective products.

• Claim procedure

Before requesting warranty service, check the operation manual to be certain that there is a problem with the controller. Return the defective product to us with shipping charges prepaid if problem cannot be solved. Provide proof of date and place of purchase. To obtain rapid service under this warranty, the returned products must include the model, serial number and detailed reason for the failure, the module type and size, type of batteries and system loads. This information is critical to a rapid disposition of your warranty claim.

• This warranty does not apply under the following conditions

1. Damage by accident, negligence, abuse or improper use.
2. PV current exceeding the ratings of product.
3. Unauthorized product modification or attempted repair.
4. Damaged occurring during shipment.
5. Damage results from acts of nature such as lightning, weather extremes.
6. Irreclaimable mechanical damage.

8.0 Specifications

Electrical

	<u>ET2415N</u>	<u>ET3415N</u>	<u>ET4415N</u>	<u>ET6415N</u>	
Nominal System Voltage		12V / 24V / 36V / 48V dc			
Nominal Battery Current	20A	30A	45A	60A	
Maximum Solar Input Voltage		150V dc			
Battery Voltage Range		8~72V dc			
Maximum Input Power					
	<u>12V</u> :	260W	400W	600W	800W
	<u>24V</u> :	520W	800W	1200W	1600W
	<u>36V</u> :	780W	1200W	1800W	2400W
	<u>48V</u> :	1040W	1600W	2400W	3200W
Self Consumption		1.4~2.2W			
Grounding		Solar or Battery Negative Terminal			
Remote Temperature Sensor Port		MC1.5-3.81-2L			
Remote Battery Voltage Sense Port		MC1.5-3.81-2L			
CAN BUS Port		MC1.5-3.81-4L			
Ethernet Port		RJ45			
Serial RS-232 Port		DB9, male			

Settings

Charging Stages	MPPT, Boost / Equalize, Float
Temp. Compensation Range	-25°C ~ +55°C
Temp. Compensated Setpoints	Equalize, Boost, Float, LVD

Table 8.1: Parameter for 12V system

Multiplied 2,3 and 4 respectively for 24V ,36V and 48V system

	Item	Default		Options & Range	
1	Batt Type	SEALED		GEL, SEALED , FLOODED	
2	Batt Rated Volt ^①	12.0 V		12.0,24.0,36.0,48.0 V	
3	Over Volt. Disc	16.0 V		15.0~17.0 V	
4	Over Volt. Rect	15.0 V		14.0~16.0 V	
5	Charging Limit	15.5 V		14.0~16.0 V	
6	Equalize Charge ^②	GEL	--	14.2~15.2 V	
		SEALED	14.6 V		
		FLOODED	14.8 V		
7	Boost Charge	GEL	14.2 V	13.8~15.0 V	
		SEALED	14.4 V		
		FLOODED	14.6 V		
8	Float Charge	13.8 V		13.2 ~14.2 V	
9	Boost Volt. Rect	13.2 V		12.7~13.5 V	
10	Under Volt.Warn	12.2 V		11.8 ~12.6 V	
11	Low Volt. Rect	12.6 V		12.0~13.2 V	
12	Low Volt. Disc	11.1 V		10.5~11.8 V	
13	Discharge Limit	10.8 V		10.5~11.0 V	
14	Equalize Time	GEL	--	GEL	--
		SEALED	120 Min	SEALED	0~180 Minutes
		FLOODED		FLOODED	
15	Boost Time	120 Minutes		0~180 Minutes	
16	Temp Coefficient	-5mV/°C/2V		- 9~0mV/°C/2V	

Notes:

① This parameter be detected auto by controller, user can't set it.

② Equalize charge interval is 28 days. No matter when LVD happens within 28 days.

③ Voltage parameters in strict accordance with:

a. Over Volt. Disc>Charge Limit>Equalize Charge>Boost Charge>Float Charge>Boost Volt. Rect.

b. Under Volt. Rcvr>Under Volt. Warn>Low Volt. Disc>Discharge Limit.

④ Parameters will be displayed as corresponding default values after correct system voltage identification.

Mechanical:

	L x W x H	Mounting	Net Weight
<u>ET2415N</u>	206 x 203 x 105 mm	150 x 193 mm	2.6kg
<u>ET3415N</u>	231 x 203 x 105 mm	150 x 193 mm	4.1kg
<u>ET4415N</u>	285 x 203 x 105 mm	200 x 193 mm	4.4kg
<u>ET6415N</u>	285 x 203 x 121 mm	200 x 193 mm	5.0kg
Terminal:	35mm ²	Mounting hole:	Φ10 (M8)

Environmental

Ambient Temp.	-25℃ ~ +55℃
Storage Temp.	-30℃ ~ +85℃
Humidity	10 ~ 90% N.C.
Altitude	≤3000 m
Enclosure	IP20

9.0 Conversion Efficiency Curves

Illumination Intensity: 1000W/m²

Temperature: 25°C

Test model: ET4415N

- 1. Solar MPPT Voltage(17V、34V、68V、100V) / System Voltage(12V)

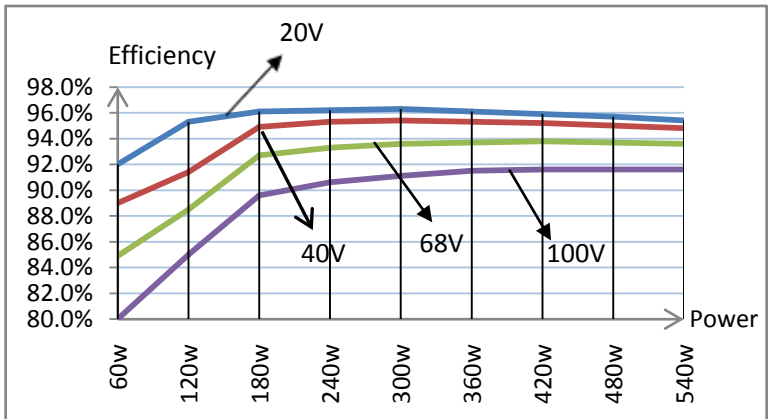

2. Solar MPPT Voltage(34V、68V、100V) / System Voltage(24V)

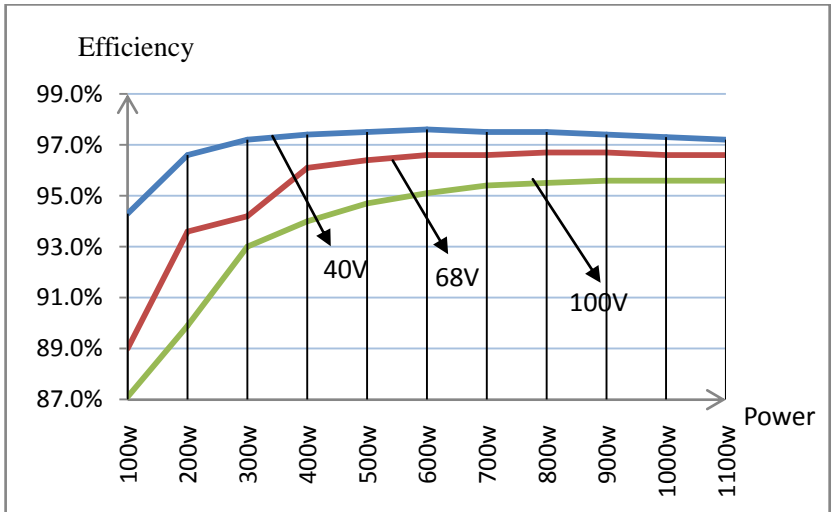

3. Solar MPPT Voltage(68V、100V) / System Voltage(36V)

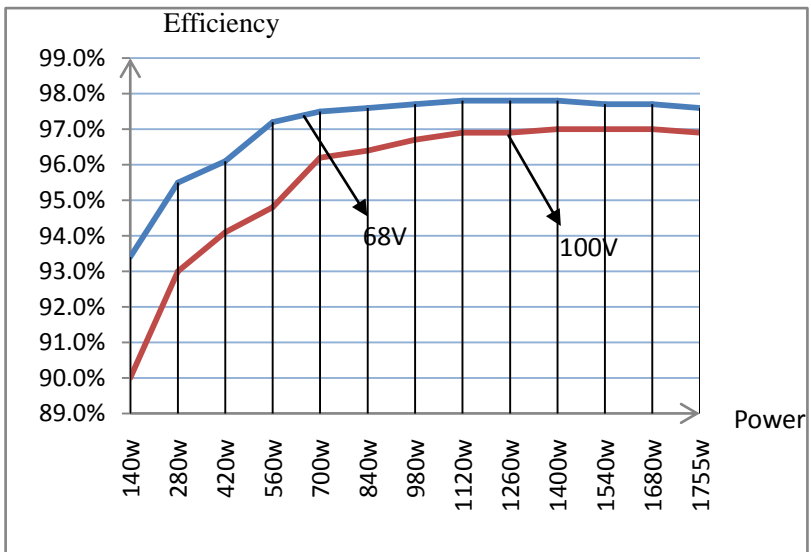

4. Solar MPPT Voltage(68V、100V) / System Voltage(48V)

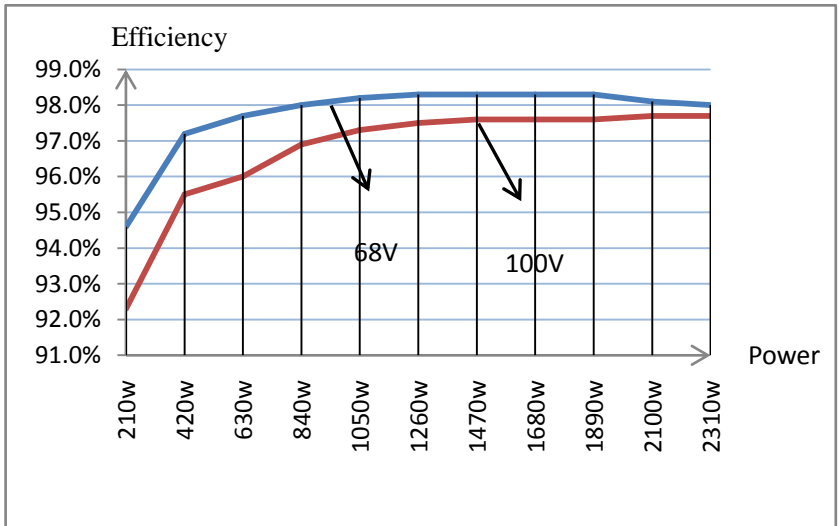

10.0 Dimensions

ET2415N Dimension (mm)

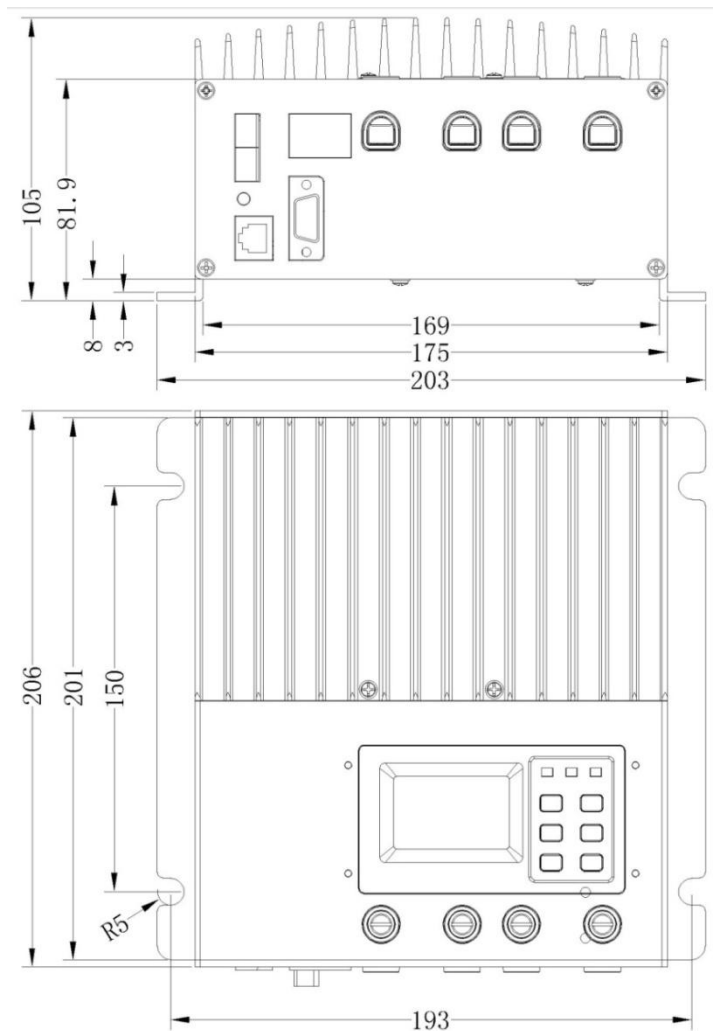

ET3415 N Dimension (mm)

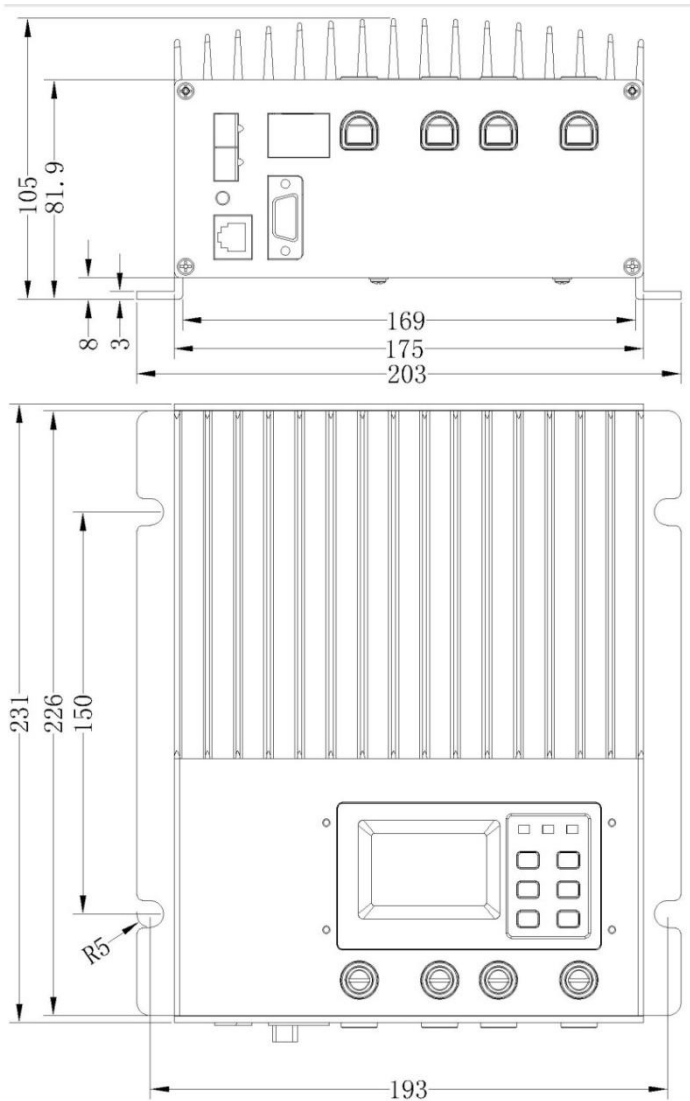

ET4415 N Dimension (mm)

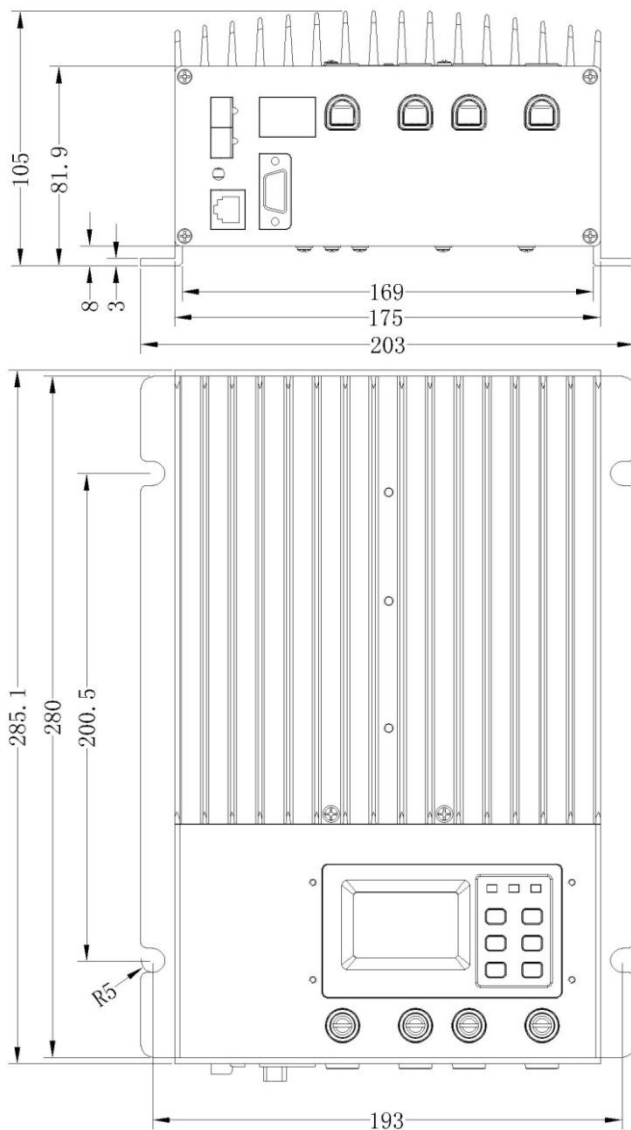

ET6415 N Dimension (mm)

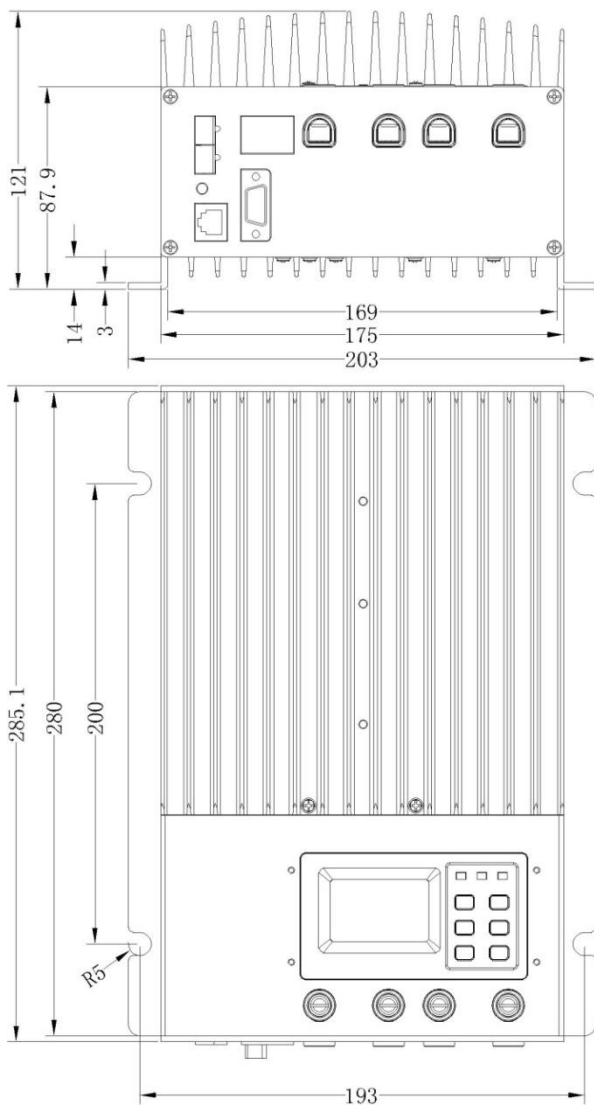

Annex1

Abbreviation explanations:

Abbreviation		explanations
Over Volt. Disc	OVD	Over Voltage Disconnect Voltage
Over Volt. Rect	OVR	Over Voltage Reconnect Voltage
Charge Limit	CLV	Charging Limit Voltage
Equalize Charge	ECV	Equalize Charging Voltage
Boost Charge	BCV	Boost Charging Voltage
Float Charge	FCV	Float Charging Voltage
Boost Volt. Rect	BVR	Boost Voltage Reconnect
Under Volt. Revr	UVR	Under Voltage Warning Recover Voltage
Under Volt. Warn	UVW	Under Voltage Warning Voltage
Low Volt. Rect	LVR*	Low Voltage Reconnect Voltage
Low Volt. Disc	LVD*	Low Voltage Disconnect Voltage
Discharge Limit	DLV	Discharging Limit Voltage
Temp Coefficient	TCC	Temperature compensation coefficient

Event explanations:

OVD	Over Voltage Disconnect Voltage (for battery)
UVW	Under Voltage Warning Voltage (for battery)
LVD*	Low Voltage Disconnect Voltage (for battery)
Current Err	The charging current in three phases is unbalanced
Over Current	The charging current is much more than the rating
Over Temp	Heat sinks operational temperature is quite high
PV OVD	Solar Voltage is higher than the rating

* LVR & LVD: only for status indicator, no reconnection or disconnection operation



BEIJING EPSOLAR TECHNOLOGY CO., LTD.

Tel: 010-82894112 / 82894962

Fax: 010-82894882

E-mail: info@epsolarpv.com

Website: www.epsolarpv.com

