

H6400
SERIES
CRANE
USER MANUAL

RIKI[®]

**Commercial Grade
Truck Equipment**

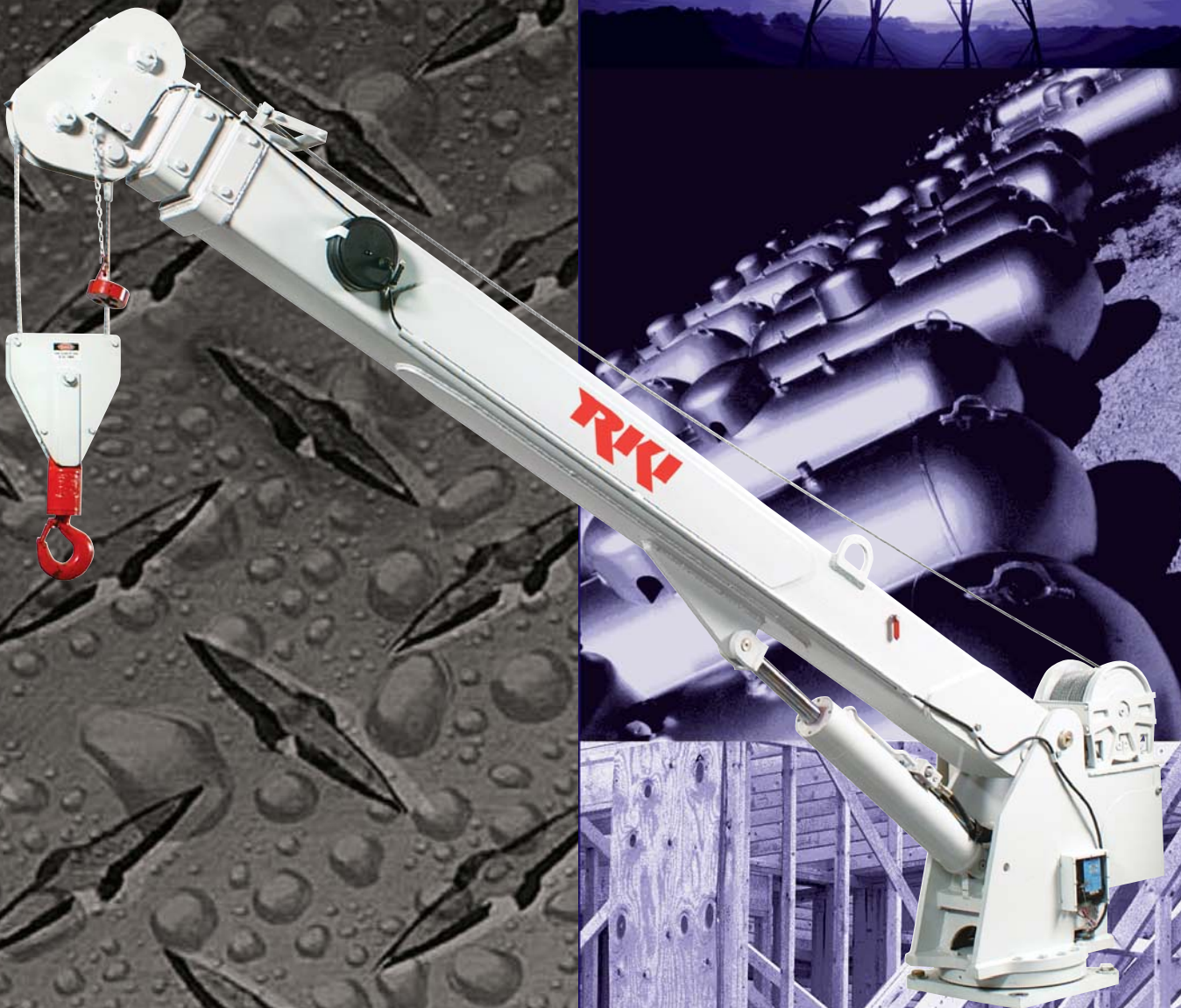

Model: H6400-6ERX20

Serial Number: _____

Date: _____

RKI, Inc.

2301 Central Parkway
Houston, TX. 77092
Phone: 713-688-4414
Fax: 713-688-8982
www.rki-us.com

IMPORTANT NOTICE

RKI, Inc. cannot possibly know or even anticipate all of the varied uses and applications that may be found for its crane products. For that reason, the company expressly disclaims any and all responsibility for the manner and methods used by the installer of these products. The company recommends that the installer of its crane products follow sound engineering principles and comply fully with each and every applicable ANSI, OSHA or other safety standard.

Safety Warning: RKI, Inc. cranes are not intended to be used, or incorporated as a component of any other equipment which may be used for the lifting or moving of people. Any such use is absolutely and categorically contrary to RKI, Inc.'s recommendation.

PACKING LIST H6400 SERIES CRANE

The following items are included with your RKI H6400 series crane.

1 - Crane Assembly

1 - User's Manual of H6400 Series Crane

1 - Carton with the Following Contents:

4 Ea. - P/N 44823	Mounting Bolt; 7/8" x 4.0" gr. 8
8 Ea. - P/N 43742	Flat Washer, 7/8" gr. 8
4 Ea. - P/N 43743	Lock Washer; 7/8" gr. 8
4 Ea. - P/N 43744	Hex Nut; 7/8" gr. 8
1 Ea. - P/N 44701	Transmitter (FM Remote Control)
1 Ea. - P/N 44702	25' Tether for Transmitter
1 Ea. - P/N 44704	Inline Fuse Holder (Blade Style)
1 Ea. - P/N 44705	15 Amp Fuse (Blade Style)
1 Ea. - P/N 44449	Toggle Switch
1 Ea. - P/N 43206	Seal - Toggle Switch

TABLE OF CONTENTS

Description	Page
IMPORTANT NOTICE	1
PACKING LIST	2
INTRODUCTION AND SPECIFICATIONS	4
OVERALL DIMENSIONS OF CRANE	6
CAPACITY CHART	7
OPERATING INSTRUCTIONS	8
INSTALLATION INSTRUCTIONS	11
ELECTRICAL & HYDRAULIC HOOKUP	13
TRANSMITTER & CONTROL MODULE OPERATING INSTRUCTIONS	14
HYDRAULIC SYSTEM OPERATING INSTRUCTIONS	17
ELECTRICAL SCHEMATIC	19
LUBE & HYDRAULIC FLUID SPECIFICATIONS	20
INSPECTION & MAINTENANCE SCHEDULE	21
BOLT TORQUE CHARTS	22
TOP LEVEL CRANE ASSEMBLY	24
BOOM ASSEMBLY	25
TURRET ASSEMBLY	26
ROTATE GEARBOX ASSEMBLY	28
HOIST WINCH ASSEMBLY	30
HYDRAULIC CONTROL VALVES ASSEMBLY	34
SPARE PARTS	35
MERCHANDISE RETURN POLICY	36
LIFETIME WARRANTY	BACK INSIDE COVER

INTRODUCTION & SPECIFICATION

INTRODUCTION:

RKI cranes are designed and manufactured to provide you years of safe, dependable performance.

This manual has been provided to give you specific information regarding the safe operation and upkeep of your crane.

It is very important that all who operate or service the crane should begin by thoroughly reading this manual. In addition, the supervisor, and others concerned with the operation of the crane, should read this manual. Remember that an uninformed or careless operator can make the operation of any equipment dangerous.

The information in this manual helps to insure that your RKI crane is installed properly and operated safely. However it is not a definitive guide to every possible situation or circumstance. If you have any questions or require additional information, please contact RKI.

SPECIFICATIONS:

Model:

H6400-6ERX20

Moment Rating:

38,000 ft. lbs

Lift Capacities:

6,400 lbs. @ 6 ft.	2,710 lbs. @ 14 ft.
4,750 lbs. @ 8 ft.	2,375 lbs. @ 16 ft.
3,800 lbs. @ 10 ft.	2,110 lbs. @ 18 ft.
3,165 lbs. @ 12 ft.	1,900 lbs. @ 20 ft.

Boom:

Power telescoping boom extension from 10' to 16', and from 16' to 20'. The boom angle varies from -5° to +75°.

FM Remote or Remote Control Pendant:

FM remote or 25' tether pendant controls all powered functions. Both configurations offer full proportional control with status display.

Two-Speed Rotation:

Two-speed rotation is a standard feature. While unloaded, the rotation speed is doubled to provide quick access to the load. When at under loaded condition, the rotation speed is reduced automatically to eliminate load swing and facilitate safe operation. The 360° continuous unlimited rotation is standard.

Line Speed: Over 55' per minute for single line

Multi-Functions:

The hydraulic configuration allows multiple functions to be performed simultaneously

Hydraulic System:

Proportional hydraulic control system with manual override and pressure compensated flow control system. A series control circuit is used.

Load Sensor:

A load sensor is standard to automatically protect overload.

Anti Two-Block:

Anti two-block feature prevents extending the boom against the traveling block and breaking the wire rope.

Winch Cable and Block:

95' of 3/8" galvanized aircraft cable is supplied with traveling block for double line operation. The swivel hook incorporates a roller thrust bearing for easier turning movement.

Electrical:

12 V.D.C. electrical solenoid valves control all the powered functions.

Safety Standards:

Meets OSHA 1910.180 requirements and ANSI B30.5 safety standards.

Specifications:

- Weight: 1,750 lbs
- Length: 12' 3"
- Width: 1' 6-3/4"
- Height: 2' 11"
- Base Plate Dimensions: 16 3/4" x 16 3/4"
- Hydraulic System Requirements: 8 gpm flow rate and 2,800 psi max. pressure
- Truck Requirements: 14,500 lbs. GVWR (Minimum)
- Outrigger: p/n ORMM894 or equivalent

OVERALL DIMENSIONS

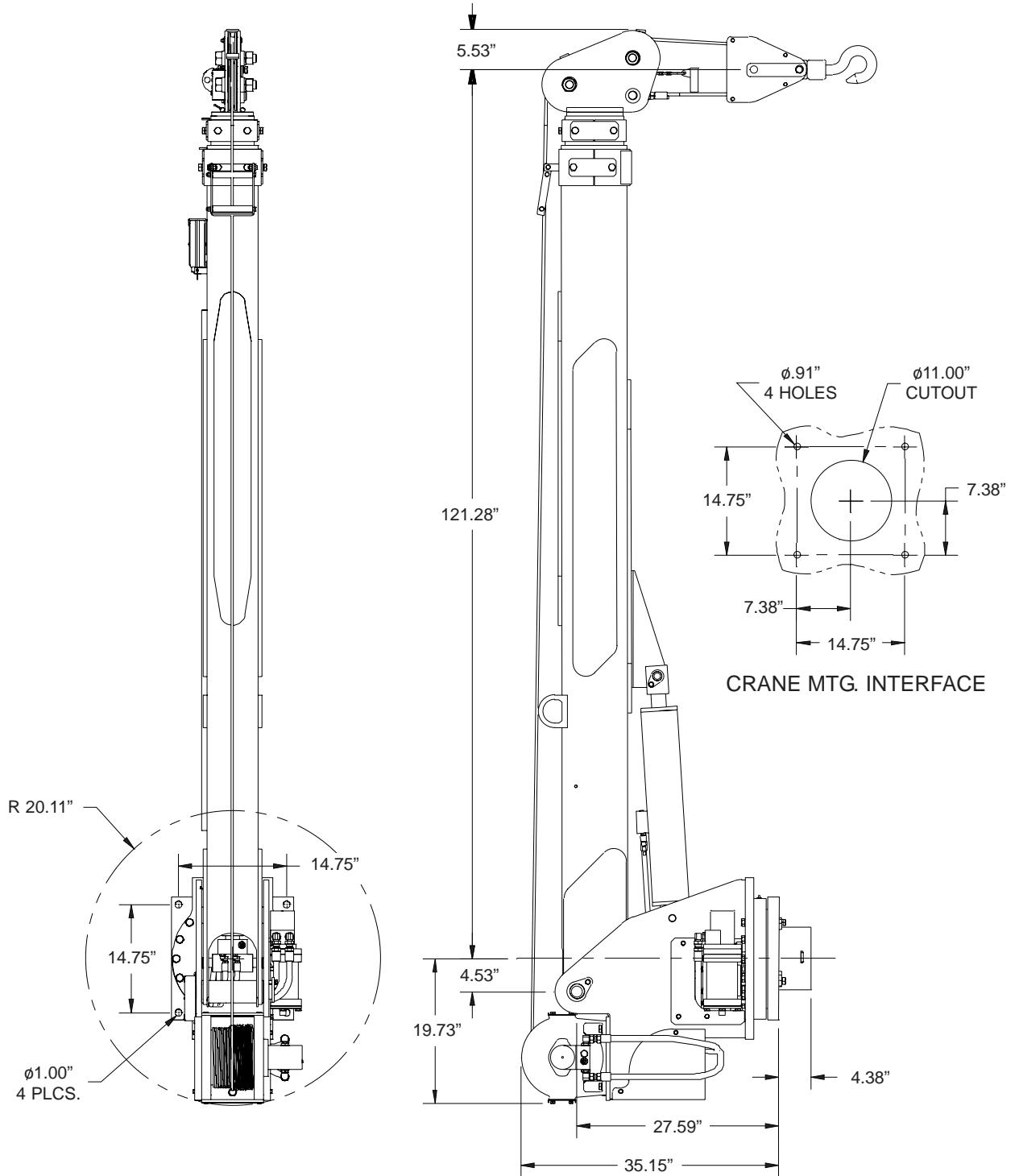

CAPACITY CHART

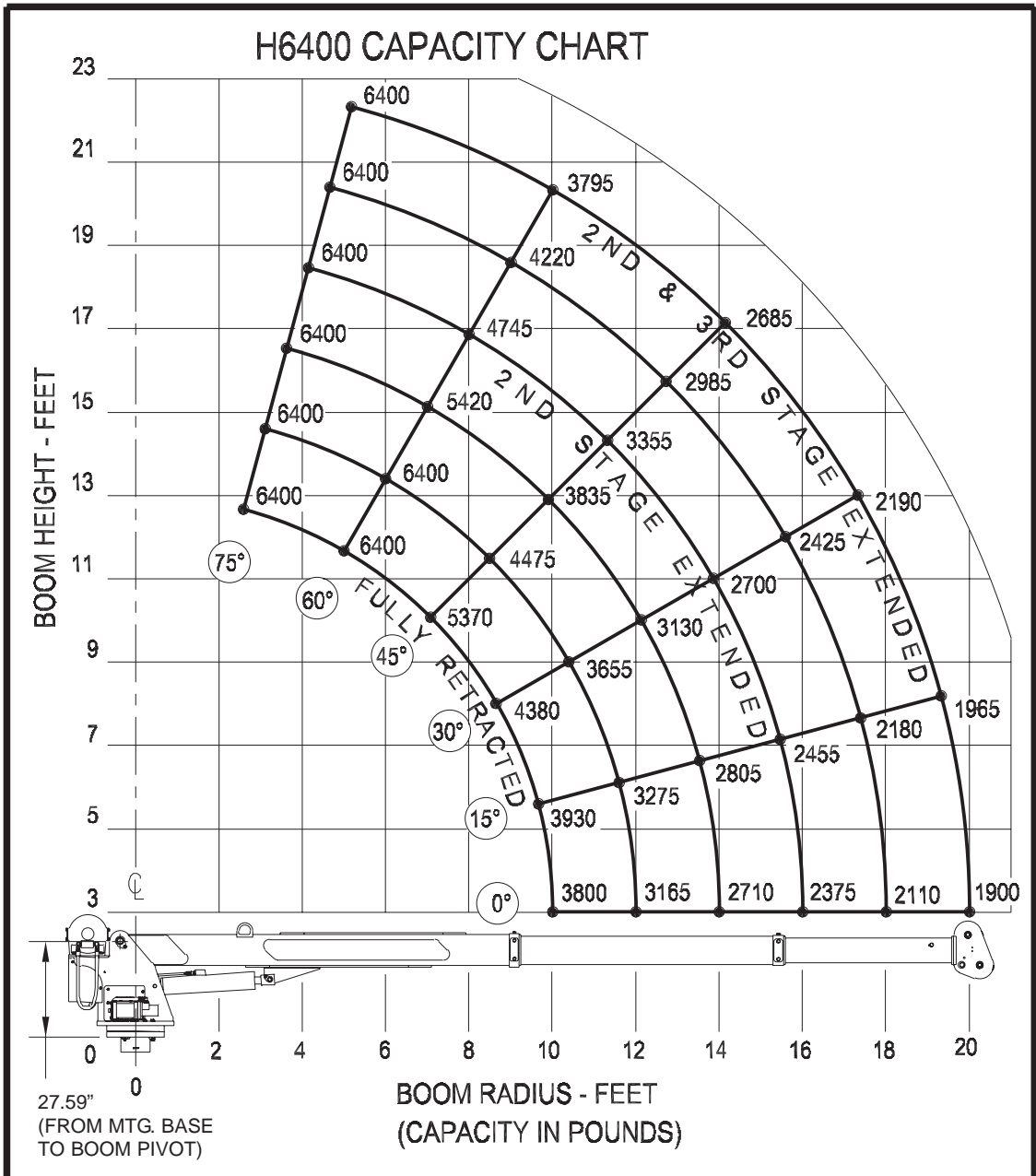

OPERATING INSTRUCTIONS

1. Do not operate this crane unless you have thoroughly read and understand the information contained in this manual.
2. Cranes shall be operated only by the following qualified personnel:
 - a. Designated persons
 - b. Trainees under the direct supervision of a designated person
 - c. Maintenance and test personnel (when it is necessary in the performance of their duty)
 - d. Inspectors (crane)
3. No one other than the personnel specified in (2) above shall enter the crane's operating area, with the exception of persons such as supervisors, and those specific persons authorized by supervisors whose duties require them to do so, and then only in the performance of their duties and with the knowledge of the operator or other appointed persons.
4. The operator shall be familiar with the equipment and its proper care. If adjustments or repairs are necessary, the operator shall promptly report this to an appointed person, and shall notify the next operator.
5. The operator at the start of each shift shall test all controls. If any controls do not operate properly, they shall be adjusted or repaired before operations are begun.
6. Seek the best possible work site for the operation when parking the truck-mounted crane. The parking location should be firm, dry and level ground or pavement, which can adequately reach the load by the rated capacity of the crane.
7. The truck-mounted crane shall not be parked on uneven, rocky or muddy terrain, steep grades and obstructed overhead locations.
8. Fully extend the outriggers out and to the ground to provide firm support and keep the truck-mounted crane as level as possible during the operation. When operating on soft terrain use wider pads or boards under the outrigger feet. Blocking under the outrigger feet shall be of sufficient strength to prevent crushing, bending, or shear failure.
9. After the truck mounted crane has been properly positioned, engage emergency brake, start the engine, place transmission in neutral position, activate PTO to circulate and warm hydraulic fluid, and set the throttle control to proper engine speed.
10. Activate the Transmitter (See Transmitter/Control Module operation for more details).
11. Lower the winch to detach the crane hook from the tie-down eye.
12. Always boom up to clear the boom support before you rotate and extend boom to desired position.
13. When operated near electric power lines, no part of the crane or load enters into danger zone shown in Figure 1.

Table 1

Normal Voltage, kV (Phase to Phase)	Minimum Required Clearance, ft (m)
Operation near High Voltage Power Line	
to 50	10 (3.05)
Over 50 to 200	15 (4.60)
Over 200 to 350	20 (6.10)
Over 350 to 500	25 (7.62)
Over 500 to 750	35 (10.67)
Over 750 to 1000	45 (13.72)
Operation in Transit With No Load and Boom Lowered	
to 0.75	4 (1.22)
Over 0.75 to 50	6 (1.83)
Over 50 to 350	10 (3.05)
Over 345 to 750	16 (4.87)
Over 750 to 1000	20 (6.10)

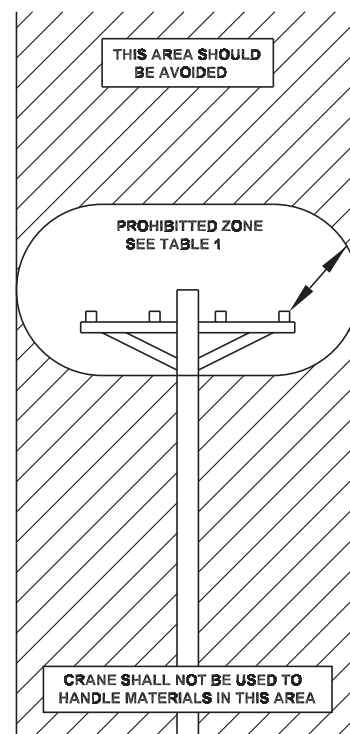

Figure 1

14. For power lines rate 50 kV or below, minimum clearance between the lines and any parts of the crane or load (including handling appendages) shall be 10 ft (3 m). For higher voltages, see Table 1.
15. Caution shall be exercised when working near overhead power lines because they can move horizontally or vertically due to wind, moving the danger zone to new position.
16. While in transit with no load and the boom lowered, the clearance shall be as specified in Table 1.
17. The crane is now in operating position and ready for handling the load.
18. No crane shall be loaded beyond the specifications of the load rated chart, except for testing purposes.
19. The load to be lifted is to be within the rated capacity of the crane (refer to crane load capacity chart).
20. When loads, which are not accurately known, are to be lifted, the person responsible for the job lift shall ascertain that the weight of the load does not exceed the crane ratings at the maximum radius at which the load is to be handled.
21. The hoist rope shall not be wrapped around the load.
22. The load shall be attached to the hook by means of slings or other devices of sufficient capacity.
23. The operator shall not leave the controls while the load is suspended.

24. No person should be permitted to stand or pass under a suspended load.
25. Before starting to lift, the following conditions should be noted:
 - a. The hoist rope shall not be kinked.
 - b. Part lines shall not be twisted around each other.
 - c. The hook shall be brought over the load in such a manner as to minimize swinging.
 - d. The effect of ambient wind on the load and on crane stability.
26. The person directing the lift shall see that:
 - a. The crane is level and, where necessary, blocked.
 - b. The load is well secured and balanced in the sling or lifting device before it is lifted more than a few inches.
 - c. The lift and swing path is clear of obstructions.
27. During lifting operations, care shall be taken that:
 - a. There is no sudden acceleration or deceleration of the moving load.
 - b. Load, boom, or other parts of the machine do not contact any obstruction.
28. Side loading of boom shall be limited to freely suspended loads. Crane shall not be used for dragging loads sideways.
29. The operator should never carry loads over people.
30. Neither the load nor boom shall be lowered below the point where less than five full wraps of rope remain on the winch drum.
31. When rotating the crane, sudden starts and stops shall be avoided. Rotating speed shall be such that the load does not swing out beyond the radius at which it can be controlled. A tag or restraint line should be used during rotation to control the load.
32. Personnel shall not be permitted to ride the bare hook or a load of material suspended from the hook.
33. Do not move the vehicle when the crane is being used.
34. The crane shall be in stowed position before traveling.

INSTALLATION INSTRUCTIONS

1. Vehicle should meet minimum GVW rating of 14,500 lbs and MUST be equipped with an engine speed control and tachometer.
2. The crane mounting base and structure must be capable of safely supporting the crane assembly weight and its maximum capacity of 38,000 ft-lbs loading.
3. The vehicle must be equipped with outriggers to provide stability.
4. Drill 4 holes with 29/32" diameter and an 11.00" diameter cut out (center with the 4 holes) of the crane mounting location.
5. Install the crane boom support in place and adjust to its lowest position.
6. Lift the crane in place and use four 7/8" diameter grade 8 bolts, flat washers and lock washers to secure the crane.
7. Tighten 7/8" diameter bolts in a criss-cross pattern, and torque the bolts to 450 ft-lbs (no lubrication on threads).
8. Adjust the boom support to contact with the boom and secure the crane hook to the hook ring.
9. Hydraulic plumbing:
 - a. Use 8 gallon reservoir and 10 microns filter.
 - b. Use #8 SAE 100R2 hydraulic hose (or equivalent) for PRESSURE line from the PTO pump to crane and #8 JIC swivel female hose end for connecting the crane. Installer will determine other fittings and hose length as required.
 - c. Use #10 SAE 100R2 hydraulic hose (or equivalent) for RETURN line from the crane to oil filter, from oil filter to reservoir and SUCTION line from reservoir to PTO pump. The return line hose end for connecting to the crane is #10 JIC female swivel. Installer will determine other fittings and hose lengths as required.
 - d. Fill the reservoir with Mobil DTE26 hydraulic fluid (or equivalent) to the top of sight glass.
10. Electrical Hookup:
 - a. If the battery negative is grounded to the vehicle's engine, install a second cable from the battery negative post to the vehicle's frame or from the engine to the vehicle's frame.
 - b. Connect RED wire to the inline fuse holder (provided) and to the battery positive (12 VDC).
 - c. Connect the WHITE wire to engine fast (optional).
 - d. Connect the ORANGE wire to engine slow (optional).
 - e. Connect the YELLOW wire to engine start (optional).
 - f. Connect the BLUE wire to engine stop (optional).
 - g. Install 15 Amp fuse (provided) to the fuse holder.
11. Start the vehicle's engine and engage PTO to circulate the hydraulic fluid through the system for 10 to 15 minutes. Verify the flow is 8 GPM with an in flow meter.

12. One at a time, operate the boom elevation cylinder and boom extension cylinder by full extension and full retraction to bleed air out from the system.
13. Operate the crane rotation, CW and CCW, and winch up and down to bleed air out from the hydraulic motors.
14. Return the boom back to the stow position.
15. Disengage PTO and refill the reservoir to the top of sight glass.
16. Inspect for any hydraulic leakage at the hose connectors.
17. Load test the crane for proper functioning and truck stability per SAE J765.

WARNING:

1. **FEDERAL LAW (49 CFR PART 571) REQUIRES THAT THE FINAL STAGE MANUFACTURER OF A VEHICLE CERTIFY THAT THE VEHICLE COMPLIES WITH ALL APPLICABLE REGULATIONS. ANY MODIFICATIONS ON THE VEHICLE PRIOR TO THE FINAL STAGE ARE ALSO CONSIDERED INTERMEDIATE STAGE MANUFACTURING AND MUST BE CERTIFIED AS TO COMPLIANCE. THE INSTALLER IS RESPONSIBLE FOR COMPLIANCE WITH ALL APPLICABLE FEDERAL AND STATE REGULATIONS AND REQUIRED TO CERTIFY THAT THE VEHICLE IS IN COMPLIANCE.**
2. **THE INSTALLER OF THE CRANE IS RESPONSIBLE TO COMPLY WITH THE OSHA TRUCK CRANE STABILITY REQUIREMENTS AS SPECIFIED BY 29 CFR PART 1910.180 (C), (I).**

ELECTRICAL AND HYDRAULIC INSTALLATION

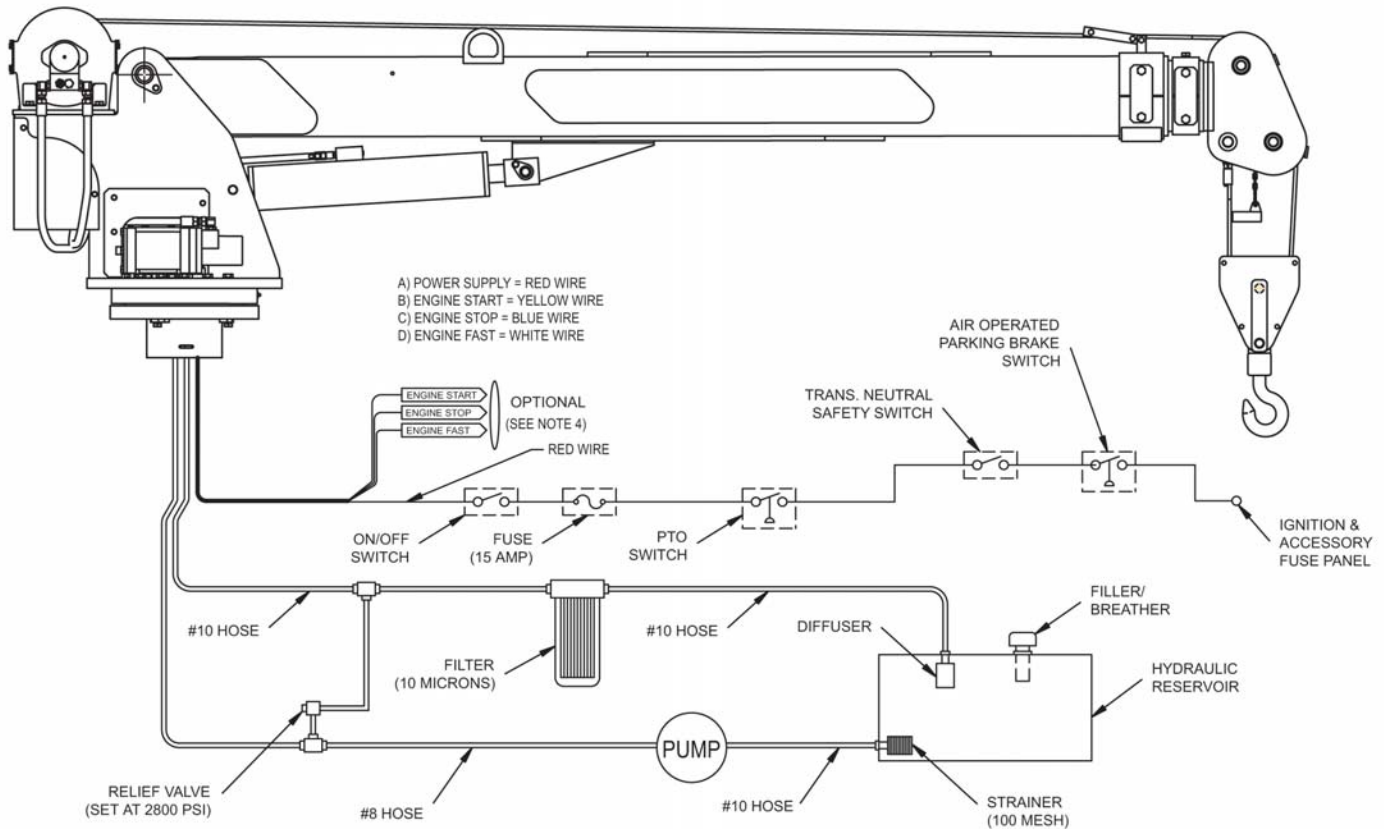

Notes:

- 1) Required #8 JIC female swivel hose end for the supply line.
- 2) Required #10 JIC female swivel hose end for the return line.
- 3) Required #16 gauge electrical wire (red color) for the power supply.
- 4) Do not connect these wires, if your truck is not equipped with these functions.

TRANSMITTER AND CONTROL MODULE OPERATING INSTRUCTIONS

FCC Rules and Compliance

This device complies with part 15 of the FCC Rules. Operation is subject to the following two conditions: (1) This device may not cause harmful interference, and (2) this device must accept any interference received, including interference that may cause undesired operation.

Change or modification not expressly approved by RKI, Inc. will limit the user's ability to operate the equipment.

This product is intended for fixed installation applications. In order to comply with FCC/ISC adopted RF exposure requirements, installation of this system's antennas must be performed in a manner that will provide at least 6 feet clearance from the front radiating aperture to anyone.

FCC Part 15.247
ISC RSS 210

INSTALL BATTERIES:

Remove the battery cover on the back of the Transmitter, and install four AA alkaline batteries.

POWER UP:

Activation of any switch will cause the Transmitter to power up. However as a safety feature, the [EStop] switch must be pressed and released, or if already pressed, released within 10 seconds for the unit to remain powered up.

USING THE TRANSMITTER:

The ACTIVE LED will flash two times per second indicating the Transmitter is transmitting to the Control Module. When a function switch is used, the ACTIVE LED will flash brightly upon activation of the switch and return to flashing at a rate of two times per seconds when there is no switch activity. During normal operation the LOW BATT LED will flash to indicate a low battery condition. The [Estop] button is used for both an emergency shutdown as well as way of powering down the Transmitter after operation. Each switch has a device specific label to identify its function. The trigger is a Proportional Control switch used in conjunction with a switch (i.e. [ROT CW]). The type of Proportional Control output is Current Control.

SETTING ID CODE:

Required when replacing either Transmitter or the Control Module.

The Transmitter has its ID Code factory programmed. Its matching Control Module needs to have this same code programmed into it. To do this, the Control Module needs to have its cover removed - refer to Figure 1. Follow the procedure below to program the Control Module ID Code to match its corresponding Transmitter.

1. Release the [Estop] switch on the Transmitter, see Figure 2.

2. Hold the ENGINE FAST/SLOW switch in the FAST position, press and release the [Estop] switch.
3. Release the ENGINE FAST/SLOW switch. The ACTIVE LED will flash one per second.
4. Press and hold the [SETUP] button (see Figure 1) on the Control Module for 5 seconds. The STATUS LED on the Control Module will flash once per second while depressed and then begin flashing rapidly indicating that the Control Module is ready to receive “Configuration Data” from the Transmitter. Release the [SETUP] button after the STATUS LED begins flashing rapidly.
5. Momentarily toggle the ENGINE FAST/SLOW switch to the FAST position; this enables the Transmitter to send “Configuration Data” to the Control Module.
6. Once the ACTIVE LED is off, power up the Transmitter and verify there is a link between the Control Module and the Transmitter.

In order to program the Control Module or replace the FUSE (use 10A MINI®), the circuit board has to be removed from the housing of the Control Module. Releasing the two side tabs on the housing and sliding the connector block and circuit board out of the housing until the four STATUS LED's are visible and the [SETUP] SW1 button is accessible. See Figure 1.

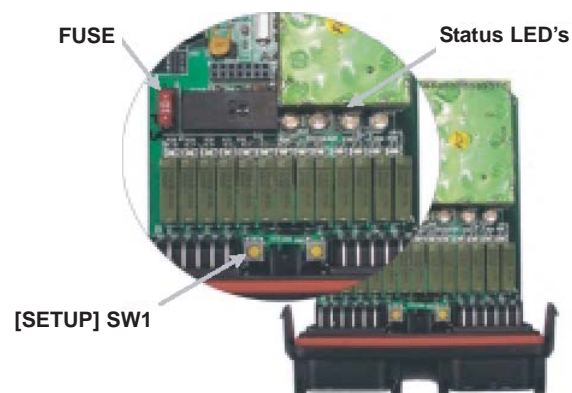

Figure 1
Control Module

CURRENT CONTROL MODULE CALIBRATION:

Permits the user to adjust minimum and maximum current of the Proportional Control

1. Release the [Estop] on the Transmitter, see Figure 2.
2. Hold the ENGINE FAST/SLOW switch in the SLOW position, press and release the [Estop] switch.
3. Release the ENGINE FAST/SLOW switch. The ACTIVE LED will flash once per second.
4. Toggle the ENGINE FAST/SLOW switch to the SLOW position. The ACTIVE and LOW BATT LED's will flash alternately once per second. This confirms the Transmitter is sending “Calibration Data” to the Control Module.
5. Select and hold one of the “Proportional Function”.
6. With the trigger OFF (fully released), the “MIN” level is set. The “MIN” level may be increased by toggling the ENGINE FAST/SLOW switch to FAST position (up) or decreased by toggling the ENGINE FAST/SLOW switch to SLOW position (down).



Figure 2
Transmitter Layout

7. Select and hold one of the “Proportional Function”.
8. With the trigger ON (fully engaged), the “MAX” level is set. The “MAX” level may be increased by toggling the ENGINE FAST/SLOW switch to FAST position (up) or decreased by toggling the ENGINE FAST/SLOW switch to SLOW position (down).
9. To reset the “MIN” and “MAX” settings to the factory default, hold either the ENGINE FAST/SLOW switch in either FAST or SLOW position (up or down) for 5 seconds.
10. To exit, press the [Estop] switch.

TROUBLESHOOTING:

The Control Module has four LED's that are used to indicate device status:

ESTOP LED:

- GREEN - Indicates RUN (normal)
- RED - Indicates ESTOP
- Flashing RED - Indicates fuse blown or relay fault

FUNCTION/FAULT LED:

- GREEN - Indicates function ON, no fault
- RED - Indicates no voltage to relay, short to ground or blown fuse
- Flashing RED - Indicates short to supply or shorted output relay
- Not lit - Indicates no function

LINK LED:

- GREEN - Indicates LINK
- RED - Indicates NO LINK

STATUS LED:

- GREEN - Indicates STATUS normal
- RED - Indicates unrecoverable fault; requiring factory authorized service
- Flashing RED - Indicates low battery

The Transmitter has two LED's that display the mode and status of the device:

ACTIVE LED:

Momentary ON or Flashing indicates POWER UP procedure or Program status. LED will flash with each function during normal operation indicating Transmit Status to the Module Control is good.

LOW BATT LED:

Momentary ON or Flashing indicates Power Up procedure or Programming status. During normal operation, this LED will only flash to indicate battery low. Battery life is 1 year.

ACTIVE and LOW BATT LED'S:

Both LED's flashing in sync indicates one of the switches is stuck.

HYDRAULIC SYSTEM OPERATING INSTRUCTIONS

MANUALLY LOWER BOOM:

In case of EMERGENCY, when the boom has to be lowered without the hydraulic flow. The procedure below should be followed:

1. Make sure the boom will be lowered on to a proper support
2. Locate the counterbalance valve at the boom elevation cylinder manifold block.
3. Loosen the hex nut and slowly turn the Allen head screw clockwise (note number of turns) until the boom just begins to lower. Remove tools and hands from the crane while the boom is lowering.

CAUTION: Do not turn the adjustment screw too far; it will damage the counterbalance valve.

4. After the boom is rested on the support, turn the Allen head screw counter clockwise about the same number of turns that were made during lowering of the boom.
5. Tighten the hex nut to secure the adjustment screw in place.
6. After the problem has been fixed and proper hydraulic flow present, re-adjust the counterbalance valve by using the procedure in the previous page.

WARNING:

Do not try to adjust the counterbalance valve while the boom is moving. This may cause personal injury.

MANUAL OVERRIDE OPERATION:

In case electricity is no longer available to operate the crane or in the event the control system failed, use the manual overrides on the hydraulic control valves to operate the crane.

1. PROPORTIONAL

- Increase hydraulic flow by turning knob clockwise.
- Decrease hydraulic flow by turning knob counter clock wise.

2. BOOM UP, BOOM OUT, ROTATE CW & WINCH UP

- Turn knob on their valves respectively clockwise.

3. BOOM DOWN, BOOM IN, ROTATE CCW & WINCH DOWN

- Turn knob on their valves respectively counter clockwise.

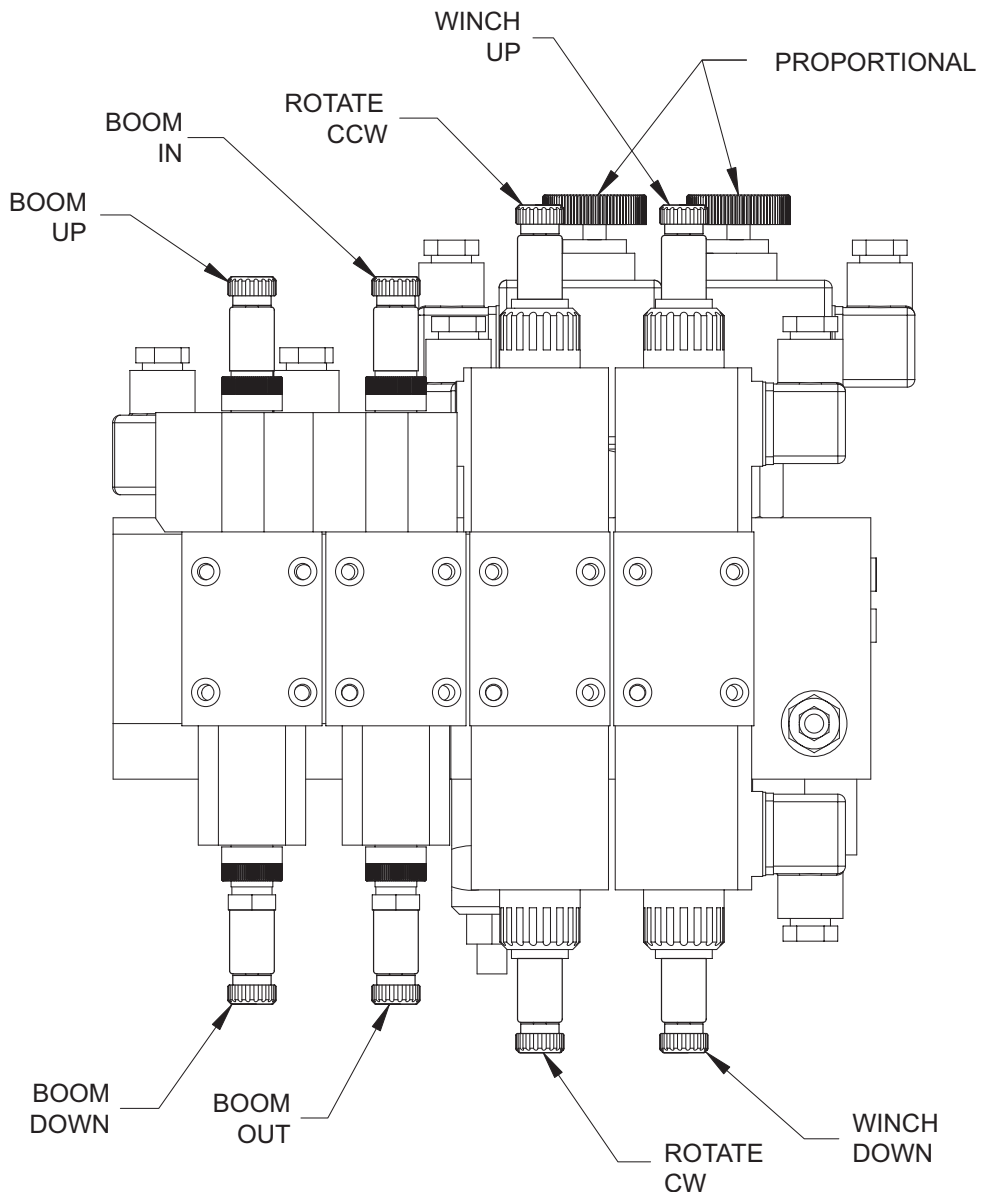

Hydraulic Valve Assembly

ELECTRICAL SCHEMATIC

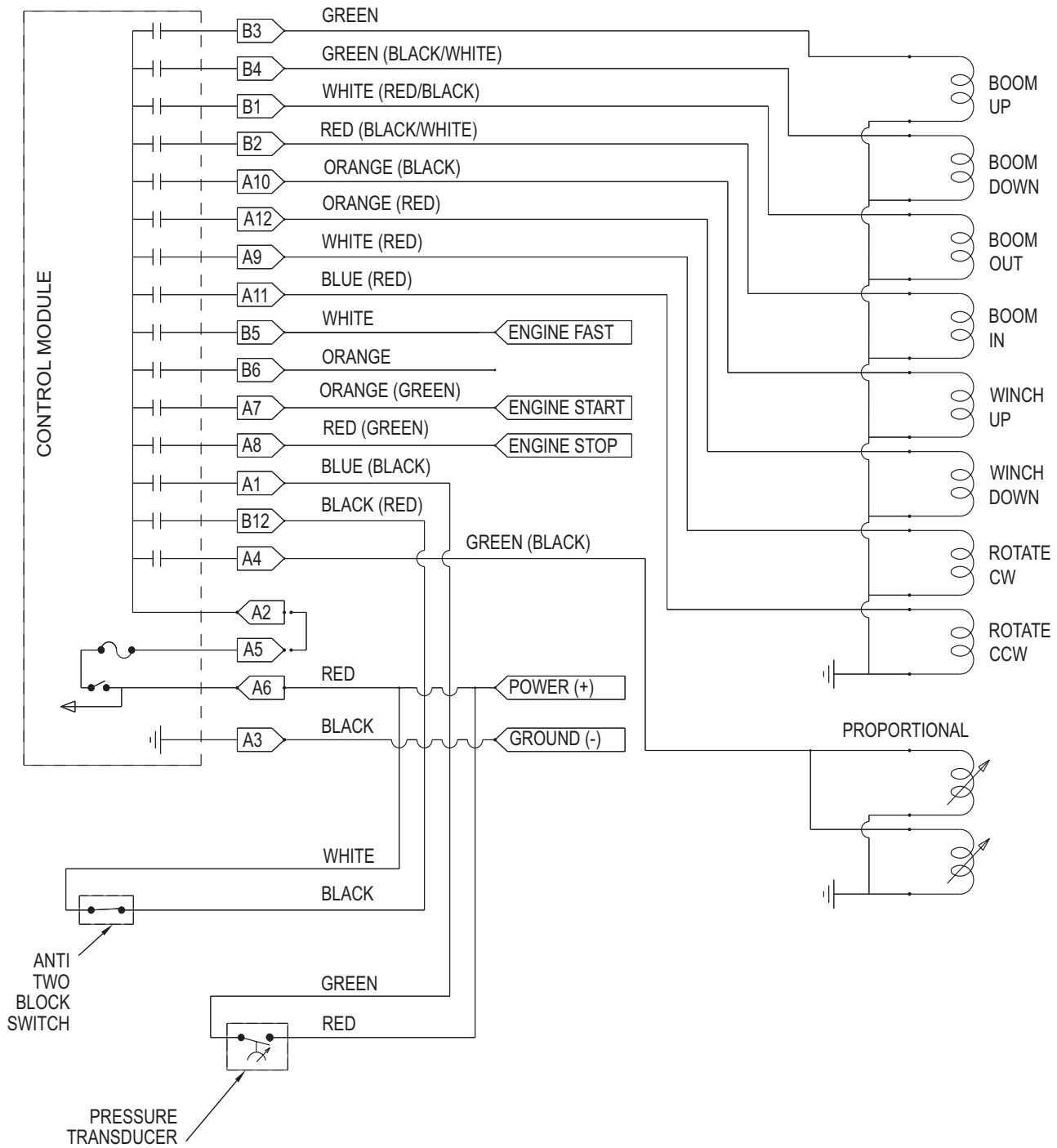

LUBRICATION & HYDRAULIC FLUID SPECIFICATIONS

1. Winch Gearbox:

a. Lubrication Specifications:

Temperature (°F)	Lubrication Type	Viscosity cSt (40°/100°C)
10 to 120	85W140	341/25
-25 to 40	80W90	145/15
-50 to 30	ISO **	31/6

** Low temperature lubricant is available from Oils Unlimited 1-800-324-115 (Syngear G-32/GL5)

Note: Unless otherwise requested, the gear oil in the winch gearbox was shipped with GL5 80W90

b. Lubrication Level:

The oil level should be checked with the winch gearbox centerline horizontal. The winch gearbox should be filled to the bottom of the fill/level plug.

c. Change Lubrication Interval:

The initial lubricant should be changed after the first 10 hrs of operation. During this “breaking in” period it is normal for the lubricant to contain minuscule black & bronze particles. Subsequent changes should be scheduled every 250 hours of operation or annually whichever come first.

2. Rotating Gearbox:

a. Lubrication Specification: EP-0 grease

b. Lubrication Level: The unit was filled with EP-0 grease from the factory

3. Slewing Bearing:

a. Lubrication Specification: Shell Alvania EP-2 grease

4. Hydraulic Fluid:

a. Fluid Specification: Mobil DTE26 or equivalent premium grade hydraulic fluid

INSPECTION & MAINTENANCE SCHEDULE

COMPONENT	DAILY	WEEKLY	MONTHLY	EVERY 3 MONTHS	YEARLY	NOTES
Check Winch Fluid	X					Change fluid after 10 hours of initial service
Change Winch Fluid					X	Replace fluid every 250 hours of operation or yearly.
Cable Drum	X					Make sure cable is wound evenly on drum
Cable	X					Check for cut or broken strands, kinking etc...
Load Hook	X					Check for any crack or deformation of hook or latch
Sheaves and Bearings				X		Inspect for any damage and add grease to bearings
Slewing Bearing				X		Add grease to bearing
Rotating Gearbox				X		Add grease to rotating gearbox
Base Mounting Bolts & Other Bolts		X				Check bolt torque for the 4 mtg. bolts (450 ft-lbs) and tighten other bolts as required
Hydraulic Hoses	X					Inspect for any damage or leakage at fittings
Hydraulic Fluid	X					Check fluid level at the reservoir before each shift
Hydraulic Filter			X			Check filter for bypass indication and replace as required
Hydraulic Reservoir					X	Drain, flush, and refill with hydraulic fluid
Boom Wear Pads				X		Inspect pads and replace as required

BOLT TORQUE CHART

COARSE THREAD

BOLT SIZE (Strength)	GRADE 2 (60,000 PSI)	GRADE 5 (105,000 PSI)	GRADE 8 (150,000 PSI)	SOCKET HEAD (170,000 PSI)
UNC	FT-LBS	FT-LBS	FT-LB	FT-LBS
1/4" - 20	5	7	10	11
5/16" - 18	9	15	21	23
3/8" - 16	17	27	38	41
7/16" - 14	27	43	60	65
1/2" - 13	40	65	92	99
9/16" - 12	58	94	133	138
5/8" - 11	81	130	184	191
3/4" - 10	90	230	326	338
7/8" - 9	146	372	526	546
1" - 8	218	558	788	818
1 1/8" - 7	309	695	1116	1159
1 1/4" - 7	436	981	1575	1635
1 3/8" - 6	572	1286	2065	2144
1 1/2" - 6	759	1707	2740	2845

Notes:

1. Torque values listed above are based on dry and plated threads.
2. A bolt that has been torqued to its rated value and then removed should be replaced.

BOLT TORQUE CHART

FINE THREAD

BOLT SIZE (Strength)	GRADE 2 (60,000 PSI)	GRADE 5 (105,000 PSI)	GRADE 8 (150,000 PSI)	SOCKET HEAD (170,000 PSI)
UNC	FT-LBS	FT-LBS	FT-LB	FT-LBS
1/4" - 28	5	11	12	13
5/16" - 24	10	22	24	25
3/8" - 24	19	40	43	46
7/16" - 20	30	62	68	73
1/2" - 20	46	96	104	112
9/16" - 18	65	137	148	154
5/8" - 18	91	192	208	216
3/4" - 16	159	336	364	378
7/8" - 14	200	534	579	601
1" - 14	244	815	883	917
1 1/8" - 12	347	1011	1252	1300
1 1/4" - 12	483	1408	1744	1811
1 3/8" - 12	651	1899	2351	2441
1 1/2" - 12	854	2490	3083	3202

Notes:

1. Torque values listed above are based on dry and plated threads.
2. A bolt that has been torqued to its rated value and then removed should be replaced.

TOP LEVEL ASSEMBLY (P/N 44650)

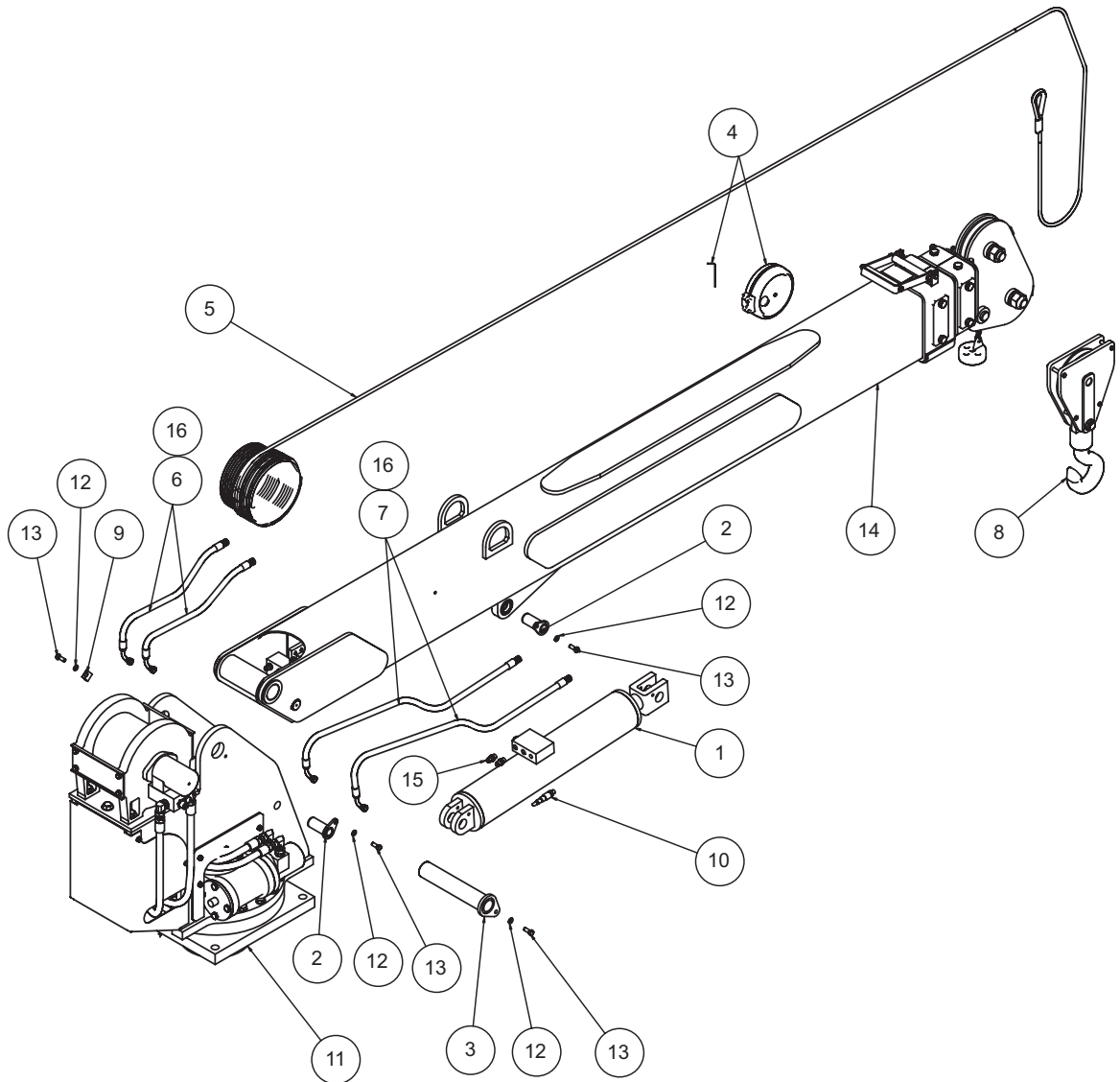

Item Number	Part Number	Description	Qty
1	44474	BOOM ELEVATION CYLINDER	1
2	44564	PIN - BOOM ELEVATION CYLINDER	2
3	44563	MOUNTING PIN - OUTER BOOM	1
4	44248	ELECT. CORD REEL	1
5	44525	WIRE ROPE - 3/8 DIA.	1
6	44560	#6 HYD. HOSE - EXT. CYLINDER 28" LG.	2
7	44649	#6 HYD. HOSE - ELEV. CYL. 38.5" LG.	2
8	44562	TRAVELING BLOCK ASSEMBLY	1
9	44561	CABLE CLAMP (ANTI TWO BLOCK)	1
10	44648	PRESSURE TRANSDUCER	1
11	44566	TURRET ASSEMBLY	1
12	03029	WASHER - FLAT .38" DIA.	3
13	07769	SCREW - CPHEX .38UNC - 1.0	3
14	44565	BOOM ASSEMBLY	1

BOOM ASSEMBLY (P/N 44565)

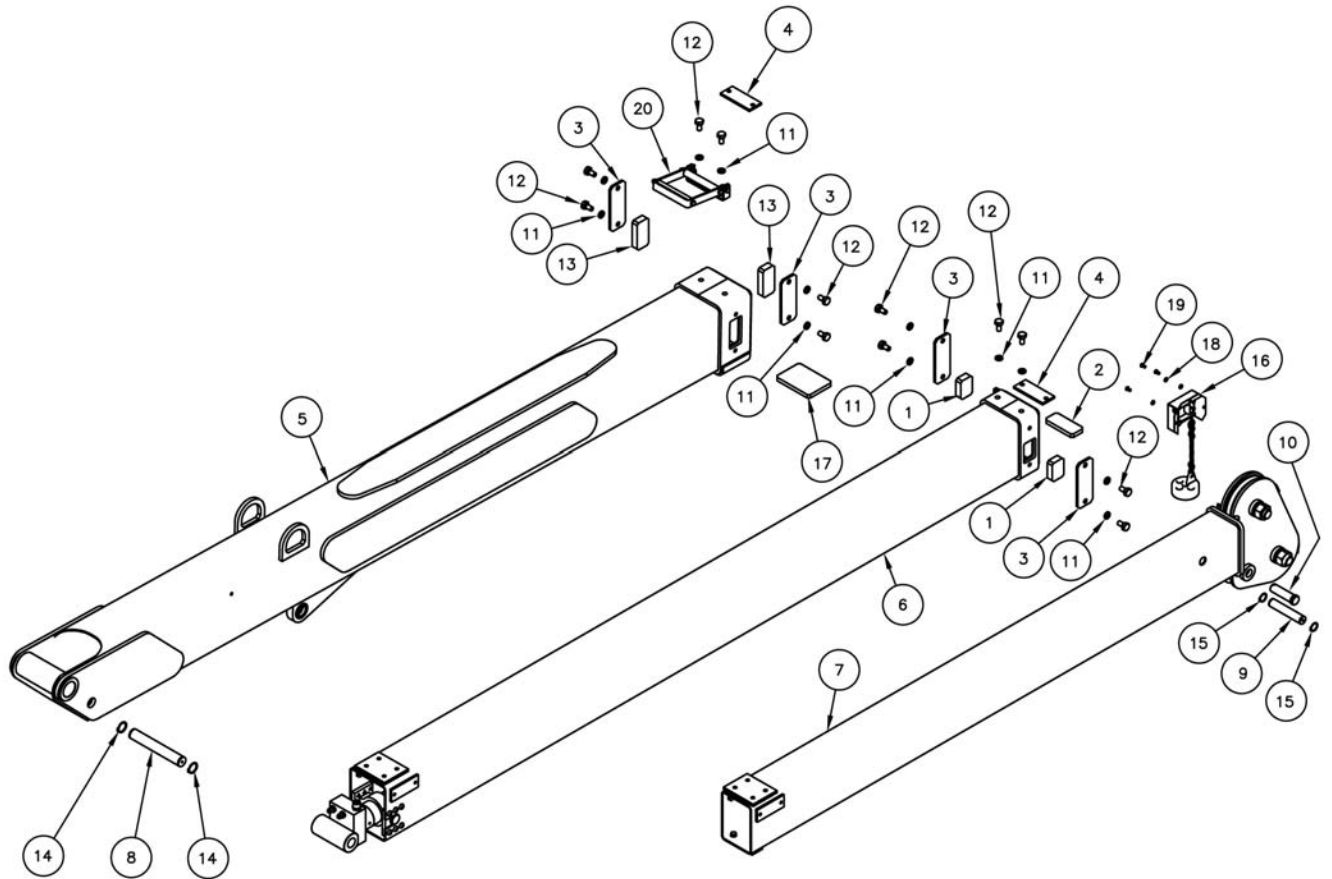

Item Number	Part Number	Description	Qty
1	44572	SIDE WEAR PAD - MIDDLE BOOM	2
2	44573	BOTTOM WEAR PAD - MIDDLE BOOM	1
3	44574	WEAR PAD COVER	4
4	44575	STOPPER	2
5	44576	OUTER BOOM	1
6	44591	MIDDLE BOOM	1
7	44598	INNER BOOM	1
8	44608	MTG. PIN - OUTER BOOM EXT. CYLINDER	1
9	44609	MTG. PIN - INNER BOOM EXT. CYLINDER	1
10	44522	CLEVIS PIN - 1.000" DIA.	1
11	03030	WASHER - LOCK .50" DIA.	12
12	07784	SCREW - CPHEX .50" 1.00"	12
13	44610	SIDE WEAR PAD - OUTER BOOM	2
14	44524	RING - RTNG EXT. 1.250" DIA.	2
15	43140	RING - RTNG EXT. 1.00" DIA.	2
16	44611	ANTI TWO BLOCK ASSEMBLY	1
17	44679	BOTTOM WEAR PAD - OUTER BOOM	1
18	07882	WASHER - LOCK .25" DIA.	3
19	44684	SCREW - CPSKB .25" X 50" (BUTTON HEAD)	3
20	44706	GUIDE - WIRE CABLE	1

TURRET ASSEMBLY (P/N 44566)

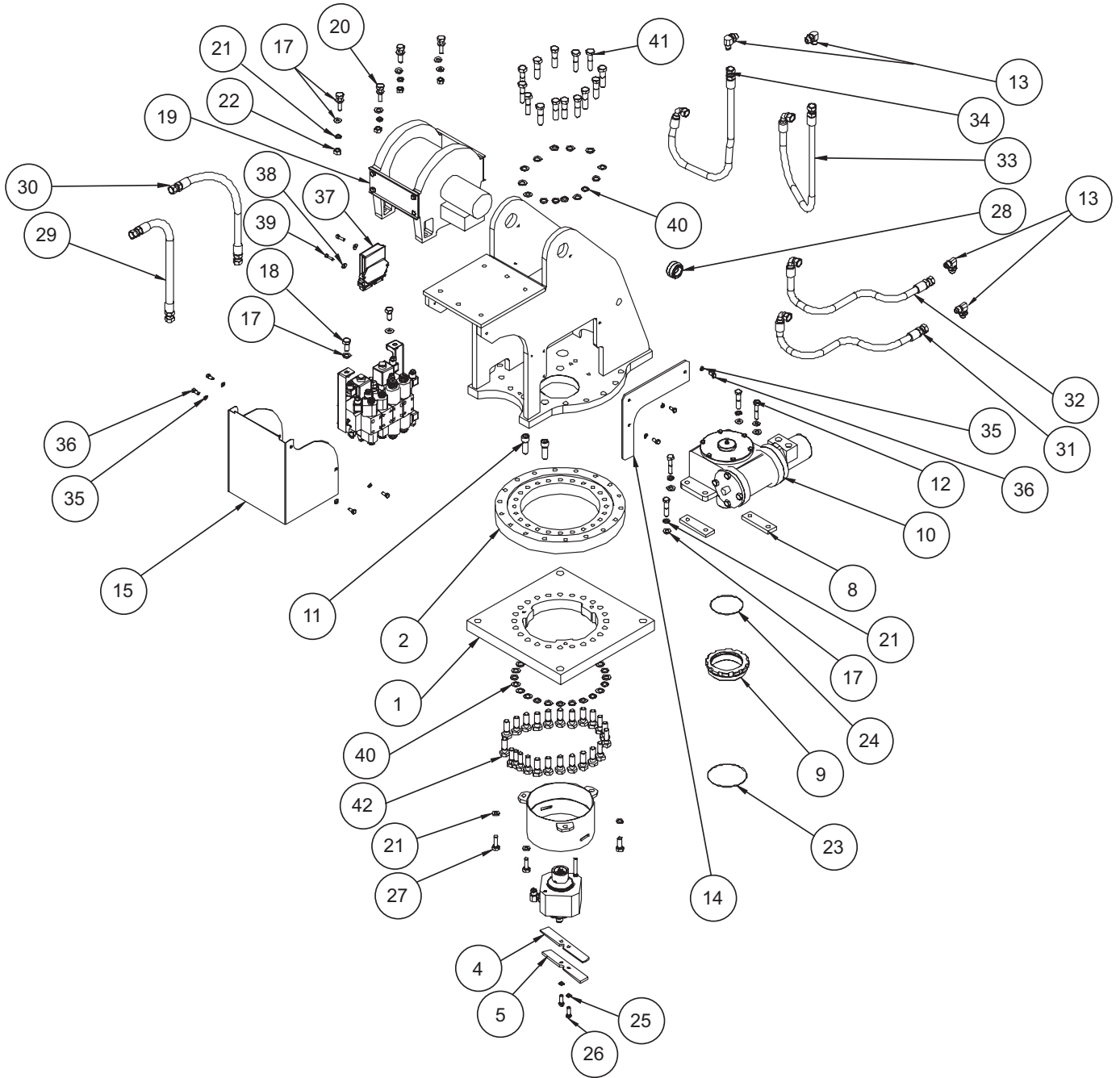

TURRET ASSEMBLY (P/N 44566)

Item Number	Part Number	Description	Qty
1	44618	BASE PLATE	1
2	W44465	BEARING	1
3	44632	COVER - HYD. SWIVEL PIN ASS'Y	1
4	44636	BRACKET - ANTI ROTATION (SWL. PIN)	1
5	44635	BRACKET - LOCKING	1
6	44628	HYDRAULIC SWIVEL PIN ASS'Y	1
7	44619	TURRET WELDMENT	1
8	44638	SPACER -REDUCER	2
9	W44466B	ECCENTRIC RING - PART OF REDUCER	1
10	W44466A	REDUCER	1
11	W44480	SCREW CPSKH .625 2.0 GR8	2
12	W44641	SCRW - CPHEX .50-13UNC-2.25 LG.	4
13	W44484	ELBOW FITTING #8 SAE TO #8 JIC	4
14	44637	COVER PLATE	1
15	44651	COVER - HYDRAULIC MANIFOLD	1
16	44646	HYDRAULIC MANIFOLD ASSEMBLY	1
17	W07889	WASHER-FLAT .50	14
18	W07785	SCREW-CPHEC .50-13UNC-1.25 LG.	2
19	W44470	WINCH	1
20	W44481	SCREW-CPHEX .50-13UNC-2.0 LG GR8	4
21	W03030	WASHER-LOCK .50	11
22	W07858	NUT-HEX .50	4
23	W44644	O-RING - INTERNAL	1
24	W44643	O-RING - EXTERNAL	1
25	W03029	WASHER-LOCK .375	2
26	W07770	SCREW-CPHEX .375-16UNC-1.25 LG.	2
27	W07786	SCREW-CPHEX .50-13UNC-1.50 LG.	3
28	W44473	SPHERICAL BEARING - CYL. LUG	1
29	W44558	HYDRAULIC HOSE 21" LG.	1
30	W44559	HYDRAULIC HOSE 23" LG.	1
31	W44555A	#8 HYDRAULIC HOSE - REDUCER-28" LG.	1
32	W44555B	#8 HYDRAULIC HOSE - REDUCER-28" LG.	1
33	W44554	#8 HYDRAULIC HOSE - WINCH - 33" LG.	1
34	W44553	#8 HYDRAULIC HOSE - WINCH - 31" LG.	11
35	W07884	WASHER-LOCK .312	7
36	W44642	SCREW-CPHEX .312-18UNC-.75 LG.	7
37	W44514	CONTROL MODULE (Includes control module, remote control, wiring harness and tether)	1
38	W40986	WASHER-FLAT .25 STD	2
39	W41015	SCREW-CPSKT .25-20UNC-.75 LG.	12
40	W44639	WASHER-FLAT .625 HARDEN	38
41	W44645	SCREW-CPHEX .625-1 1 UNC-2.50 LG.	14
42	W44463	SCREW-CPHEX .625-1 1 UNC-2.0 LG.	24

ROTATE GEARBOX ASSEMBLY (P/N 44466*)

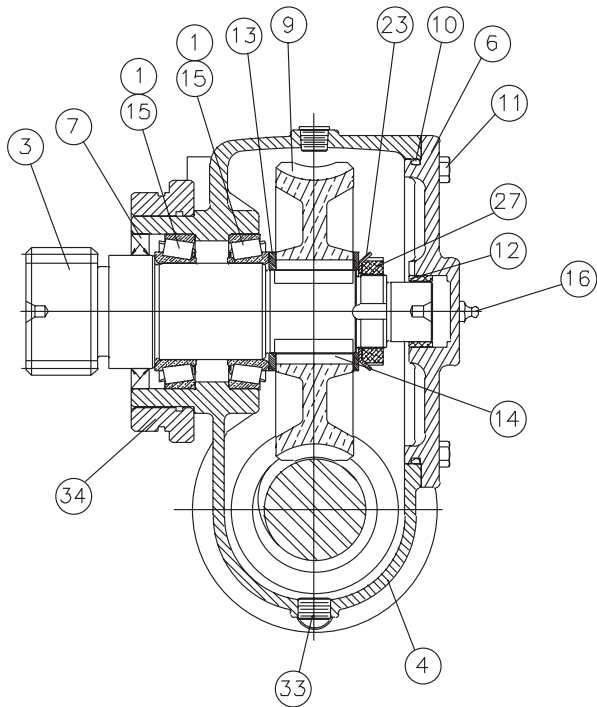
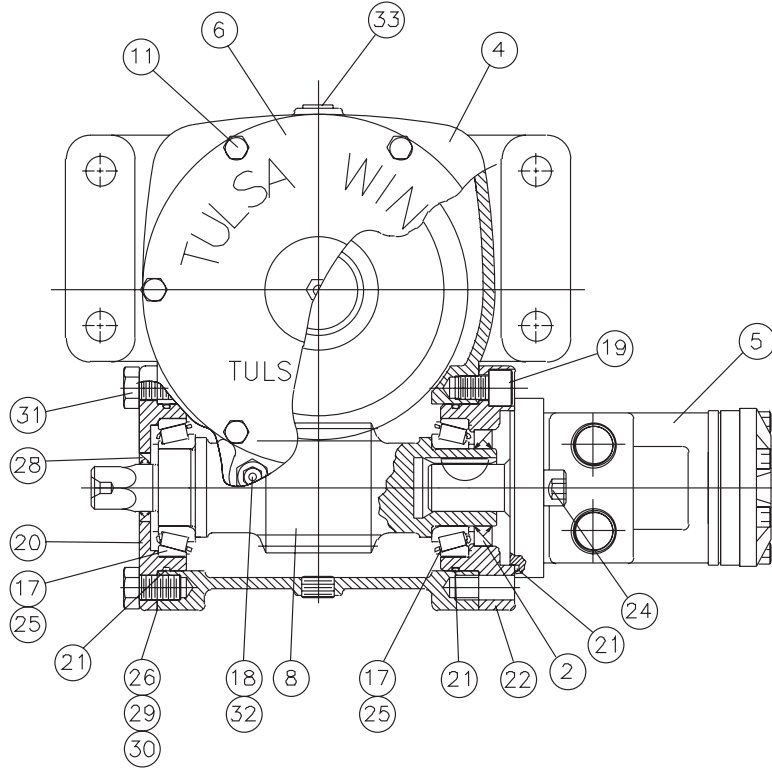

ROTATE GEARBOX ASSEMBLY (P/N 44466*)

Item Number	Tulsa Part Number	Description	Qty
1	41983	CUP, BEARING, HFG938D	2
2	33155	SEAL, OIL	1
3	43945	SHAFT, OUTPUT, PINION, HFG945D	1
4	43492	HOUSING, 900D	1
5	42765	MOTOR, HYDRAULIC, C/L H+	1
6	42000	COVER, HFG938D	1
7	41979	SEAL, OIL, HFG938D	1
8	43745	WORM, SR, HFG945D	1
9	42578	GEAR, S.R., HFG945D	1
10	40547	O-RING	1
11	40407	CAPSCREW	6
12	17451	BUSHING, HFG900D	1
13	40510	WASHER, THRUST	2
14	40518	KEY	2
15	41982	CONE, BEARING, HFG938D	2
16	21128	FITTING, GREASE ZERK	1
17	996515	CONE, BEARING	2
18	12208	BUSHING, PIPE	1
19	43537	CAPSCREW, SOCKET HEAD	2
20	43467	CAP, END, 900D	2
21	32566	O-RING	3
22	43465	CAP, END, MOTOR, 900D	1
23	41299	LOCKWASHER	1
24	41024	CAPSCREW	2
25	996516	CUP, BEARING	2
26	42366	SHIM, G1600D	2
27	26528	LOCKNUT	1
28	24180	SEAL, OIL	1
29	42367	SHIM, G1600D	2
30	42368	SHIM, G1600D	2
31	24943	CAPSCREW	4
32	13050	BREATHER	1
33	32220	PLUG, PIPE	2
34	40622	RING, ECCENTRIC, FG945	1

* TULSA GEARBOX ASSEMBLY PART NUMBER: 81881

HOIST WINCH (P/N 44470*)

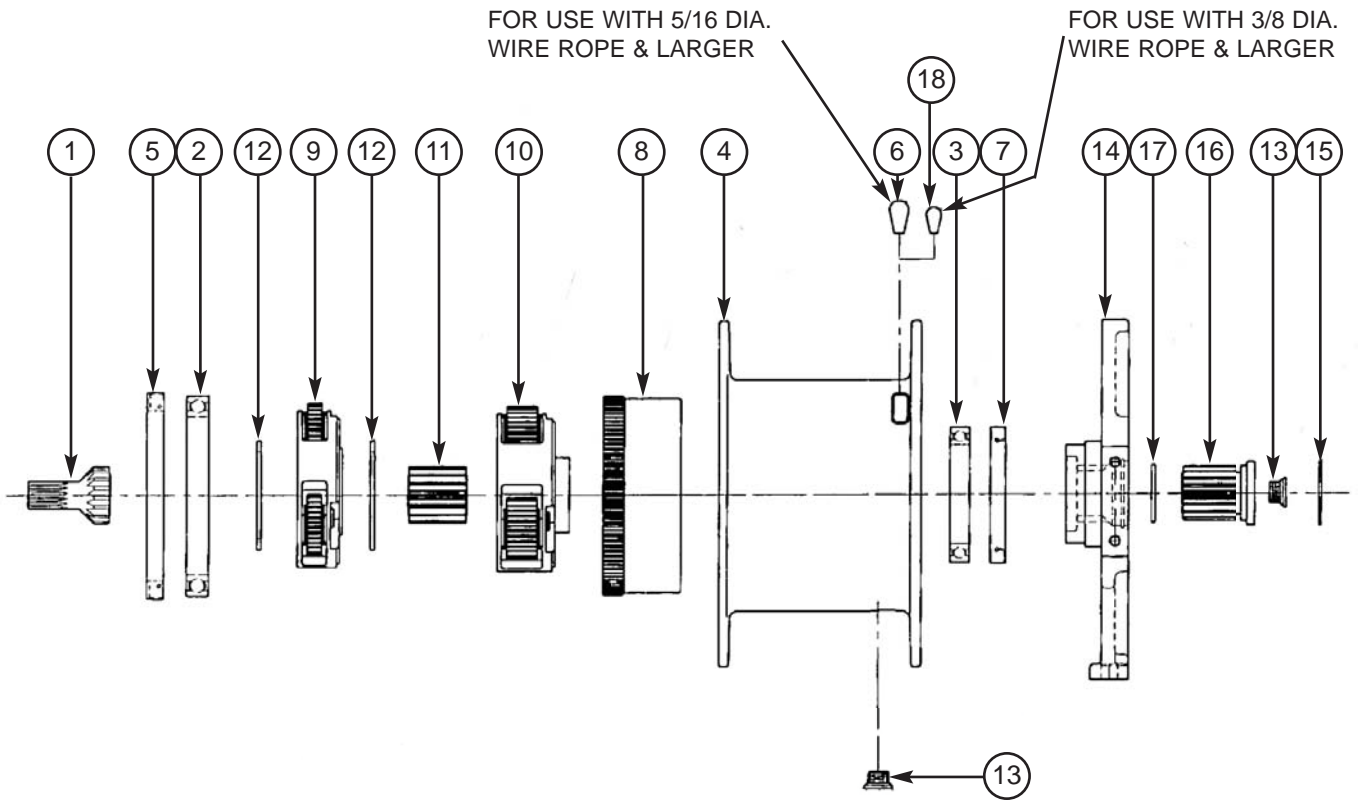

1.30156 INSTALLATION

HOIST WINCH (P/N 44470*)**1.30156 INSTALLATION**

Item Number	Tulsa Part Number	Description	Qty
1	13942	GEAR - SUN - 18 TEETH	1
2	81488	BRG - BALL - 130 I.D. x 165 O.D. x 18	1
3	81489	BRG - BALL - 80 I.D. x 110 O.D. x 16	1
4	13709	DRUM	1
5	9714	SEAL - OIL - DOUBLELIP - 140 I.D. x 170 O.D.	1
6	52688	CABLE - WEDGE - 7/16" THICK x 1.06"	1
7	9614	SEAL - OIL - 3 3/8 I.D.	1
8	13710	GEAR - RING - 56 TEETH	1
9	13695	ASSEMBLY - CARRIER - PRIMARY	1
10	14113	ASSEMBLY - CARRIER - SECONDARY	1
11	13692	GEAR - SUN - 16 TEETH	1
12	13702	WASHER - THRUST-2 3/4 I.D.x3 1/2 O.D.x.135	2
13	76146	PLUG - O-RING - SAE #8-SOCKET HEAD - 3/4 - 16	3
14	14410	SUPPORT - GEAR - END	1
15	3700	RING - RETAINER - 2 3/8 x .078 THICK	1
16	14111	COUPLING - SPLINE	1
17	9740	O-RING - 2 I.D. x 1/8 SECTION	1
18	13861	CABLE - WEDGE 2/3 x 1 13/32	1

* TULSA HOIST WINCH ASSEMBLY PART NUMBER: K5BAS1L1B

HOIST WINCH (P/N 44470*)

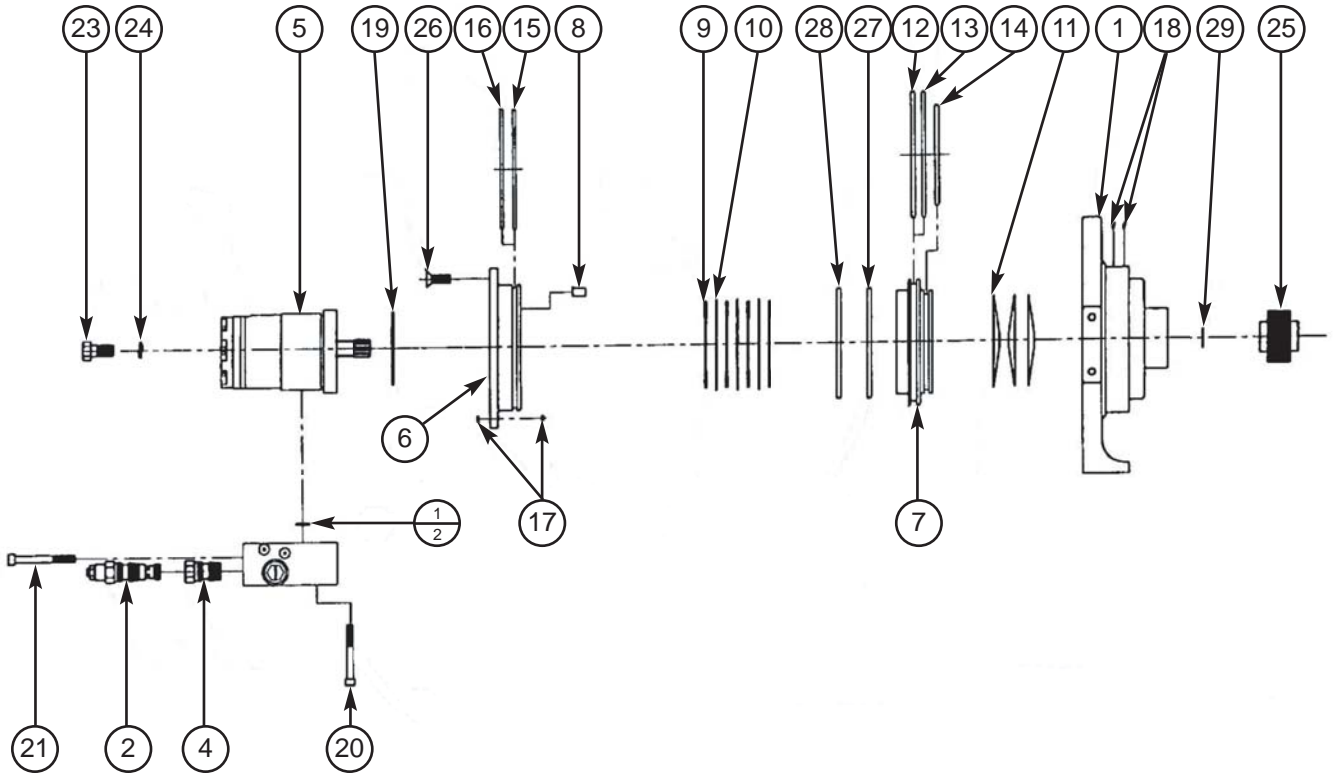

MOTOR END INSTALLATION 1.10322

HOIST WINCH (P/N 44470*)

Item Number	Tulsa Part Number	Description	Qty
1	13708	SUPPORT - MOTOR END	1
2	70040	CARTRIDGE - VALVE	1
3	13936	VALVE - COUNTERBALANCE	1
3.1	9612	O-RING - 1/8 I.D. x .103 SECTION	1
3.2	9972	O-RING - 5/8 I.D. x 3/32 SECTION	1
4	70042	PLUG - SUN - T11A	1
5	73212	MOTOR - HYDRAULIC	1
6	13602	ADAPTER - MOTOR	1
7	13603	PISTON - BRAKE	3
8	3437	PIN - DOWEL - 3/8 x 5/8	4
9	13934	PLATE - FRICTION - BRAKE	3
10	13034	PLATE - STATIONARY - BRAKE	3
11	3607	SPRING - BELLEVILLE - 4 x 2 x .12 x 1.4	1
12	9851	O-RING - 5 3/8 I.D. x 3/16 SECTION	1
13	9852	RING - BACKUP - 5.278 I.D. x .076	1
14	9709	O-RING - 4 3/8 I.D. x 3/16 SECTION	1
15	9843	O-RING - 5 1/2 I.D. x 5 3/4 O.D. x 1/8	1
16	9846	RING - BACKUP - 5 1/2 I.D.	1
17	9621	O-RING - 1/8 I.D. x .103 SECTION	2
18	3440	PLUG - HOLE - EXPANDER	2
19	9637	O-RING - 3 1/4 I.D. x 3/32 SECTION	1
20	1167	CAPSCREW - SOCKETHEAD - 5/16 NC x 2	4
21	4076	CAPSCREW - SOCKETHEAD - 1/4 NC x 4 1/2	1
22	10708	TAG - WARNING	1
23	1454	CAPSCREW - SOCKETHEAD - 1/2 NC x 1 1/4	2
24	1144	WASHER - LOCK - 1/2 - HI COLLAR	2
25	13933	BRAKE ASSEMBLY	1
26	4344-8	CAPSCREW - FLAT SOCKETHEAD - 3/6 NC x 7/8 - GR 8	6
27	9600	O-RING - 4 3/4 I.D. x 5 1.8 O.D. x 3/16 SECTION	1
28	9711	RING - BACKUP - 4 3/4 I.D. x .183 SECTION	1
29	3460	RING - RETAINER - 3/4 x .035 THICK	1

* TULSA HOIST WINCH ASSEMBLY PART NUMBER: K5BAS1L1B

HYDRAULIC CONTROL VALVE ASSEMBLY (P/N 44646)

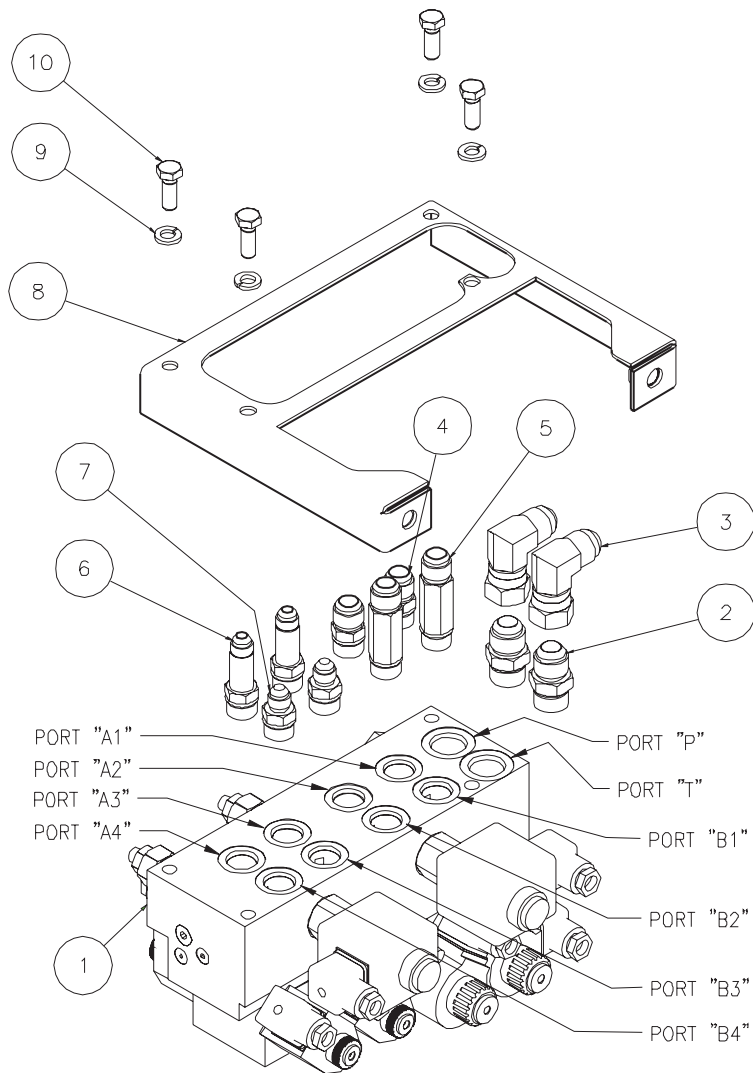

Item Number	Part Number	Description	Qty	Note
1	44515	HYDRAULIC MANIFOLD	1	
2	44541	STRAIGHT ADAPTER #10 SAE TO #10 JIC	2	TO PORT "P" & "T"
3	44537	90 DEG. ELBOW ADAPTER #10 JIC	2	TO ITEM 2
4	44535	STRAIGHT ADAPTER #8 SAE TO #8 JIC	2	TO PORT "A1" & "A2"
5	44556	STRAIGHT ADAPTER #8 SAE TO #8 JIC (LONG)	2	TO PORT "B1" & "B2"
6	44557	STRAIGHT ADAPTER #8 SAE TO #6 JIC (LONG)	2	TO PORT "A3" & "A4"
7	44538	STRAIGHT ADAPTER #8 SAE TO #6 JIC	2	TO PORT "B3" & "B4"
8	44647	MANIFOLD BRACKET WELDMENT	1	
9	03029	LOCK WASHER .375	4	
10	07769	SCREW - CPHEX .375 - 16UNC - 1.0 LG.	4	

SPARE PARTS

It is recommended that repair parts for your crane be obtained from your local RKI distributor. Please note that unauthorized servicing or alteration of your crane will void the warranty.

Each crane is assigned a serial number, which is located on the base plate. The serial number can also be found in the owner's manual that is provided with the crane.

Please record your serial number and retain a copy of your invoice for future reference. If your crane should need service, this information will be required.

MERCHANDISE RETURN POLICY

Occasionally, circumstances justify a customer returning merchandise to the factory. **No merchandise will be accepted without prior return authorization.**

Request a **Return Authorization** through our **Warranty Department**. Please provide the following information.

1. Reason or reasons for return.
2. Quantity.
3. Model Number.
4. Description.
5. Original Invoice Number.

RKI will review the information. If all criteria are met, RKI will fax or mail a **Return Authorization Form** listing each item you request to return. Material received at the factory with a proper **Return Authorization** will be inspected. If all criteria are met, the item will be repaired or a **credit** will be issued for the appropriate amount.

Due to insurance reasons, winch and crane parts are not returnable.

New material is rarely accepted for return. If it is approved to return, it will not be credited at full net. A minimum 20% restocking charge will apply.

Factors such as material handling cost, repackaging charges, and other conditions must be taken into consideration.

No custom products or “one-time-only” products may be returned.

No returns are allowed after 30 days from the date on the invoice.

The material must be received **within 30 days** of the faxing or mailing from RKI of the “**AUTHORIZATION FOR RETURN**”. If the material is not received within this time period, the **AUTHORIZATION FOR RETURN** is voided.

RKI LIFETIME WARRANTY

This warranty applies to anything we have manufactured.

The warranty applies to the original owner of the product for as long as he or she owns the product.

If something goes wrong which we determine was our fault we will repair or replace your product. The warranty doesn't apply to normal wear and tear.

Be sure to call your local distributor if you have a problem. We need the opportunity to talk to you about it. We may ask you to email us pictures or ship the product back to us for inspection.

Parts that we use but don't manufacture are covered to the extent of the warranty we get from the company that does manufacture them.

No loss of use coverage. No freight coverage. Repairs have to be authorized by us, in writing, in advance. No coverage if the product has been changed in any way.

To qualify for warranty the product must have been treated with respect in regard to normal installation, maintenance, and usage.

Accidents and acts of God aren't covered.

This warranty will be in effect until we decide to change it.

Other RKI Quality Products

- > Aluminum Treadplate and Steel Truck Boxes for Pick-Up Trucks and Flatbeds
- > Canopy Bodies
- > Custom Truck Boxes and Service Bodies
- > Line Bodies
- > Saddle Compartments
- > Service Bodies
- > Space Packs
- > Versatile Storage Systems
- > Window Grilles

RKI manufactures special cranes - consult your nearest dealer with your custom needs.

IN ORDER TO PROVIDE YOU WITH THE MOST INNOVATIVE AND PROGRESSIVE EQUIPMENT, SPECIFICATIONS, AND DESIGNS ARE SUBJECT TO CHANGE WITHOUT NOTICE.

**RKI**

www.rki-us.com

RKI, Inc.

2301 Central Parkway

Houston, Texas 77092

713.688.4414

FAX: 713.688.8982

5933 Eden Drive

Fort Worth, Texas 76117

817.314.5159

FAX: 817.831.4462