

Installation Manual

COLOR SCANNING SONAR

FSV-30/FSV-30S

SAFETY INSTRUCTIONS	i
SYSTEM CONFIGURATION	iii
EQUIPMENT LISTS	iv
1. MOUNTING THE EQUIPMENT	1-1
1.1 Hull Unit	1-1
1.2 Processor Unit	1-8
1.3 Control Unit.....	1-9
1.4 Transceiver Unit.....	1-12
1.5 Grounding the Equipment.....	1-12
1.6 Installing the Attachment Flange (option).....	1-13
1.7 Cable Extension Kit (option)	1-14
1.8 Installing the Attachment Kit (option).....	1-15
2. WIRING	2-1
2.1 How to Use the Crimping Tool, Pin Extractor	2-1
2.2 Wiring.....	2-2
2.3 Processor Unit	2-4
2.4 Transceiver Unit.....	2-10
2.5 Cable Extension Kit	2-14
2.6 Input Voltage and Fuses	2-18
3. ADJUSTMENT AND CHECK	3-1
3.1 Hull Unit Check	3-1
3.2 Heading Adjustment.....	3-5
3.3 Configuring Own Ship Mark	3-7
3.4 Other SYSTEM Menu Items	3-9
3.5 CONE Board Setting in the Processor Unit.....	3-13
3.6 DIP Switch Setting	3-14
4. CONNECTING THE EXTERNAL INTERFACE CS-120A	4-1
PACKING LISTS	A-1
OUTLINE DRAWINGS	D-1
INTERCONNECTION DIAGRAMS	S-1



ECF

(Elemental Chlorine Free)

The paper used in this manual
is elemental chlorine free.

FURUNO ELECTRIC CO., LTD.

9-52 Ashihara-cho,
Nishinomiya, 662-8580, JAPAN

Telephone : +81-(0) 798-65-2111

Fax : +81-(0) 798-65-4200

• FURUNO Authorized Distributor/Dealer

All rights reserved. Printed in Japan

Pub. No. IME-13230-F

(TATA) FSV-30/30S

A : DEC. 2003

F : DEC. 13, 2010

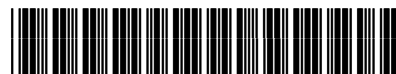

* 0 0 0 1 4 8 5 7 4 1 5 *



SAFETY INSTRUCTIONS

DANGER



Keep away from moving shaft of the hull unit.

Gears may cause injury.

WARNING



Do not open the cover unless totally familiar with electrical circuits and service manual.

High voltage exists inside the equipment, and a residual charge remains in capacitors several minutes after the power is turned off. Improper handling can result in electrical shock.

Turn off the power at the switchboard before beginning the installation.

Fire or electrical shock can result if the power is left on.

Do not install the equipment where it may get wet from rain or water splash.

Water can cause fire or electrical shock, or damage the equipment.

Be sure no water leaks in at the transducer installation site.

Water leakage can sink the vessel. Also confirm that the transducer will not loosen by ship's vibration. The installer of the equipment is solely responsible for the proper installation of the equipment. FURUNO will assume no responsibility for any damage associated with improper installation.

WARNING

Install the specified transducer tank in accordance with the installation instructions. If a different tank is to be installed the shipyard is solely responsible for its installation, and it should be installed so the hull will not be damaged if the tank strikes an object.

The tank or hull may be damaged if the tank strikes an object.

If a steel tank is installed on a wooden or FRP vessel, take appropriate measures to prevent electrolytic corrosion.

Electrolytic corrosion can damage the hull.

Be sure that the power supply is compatible with the voltage rating of the equipment.

Connection of an incorrect power supply can cause fire or damage the equipment.

CAUTION



Ground the equipment to prevent electrical shock and mutual interference.



CAUTION

Maximum speed while the transducer is projected or being raised or lowered is as below, to prevent damage to the transducer.

	Projected	Raising/ Lowering
1200 mm stroke	Max. 18 kt	Max. 15 kt
1600 mm stroke	Max. 15 kt	Max. 12 kt

Observe the following compass safe distances to prevent interference to a magnetic compass:

	Standard compass	Steering compass
Processor Unit	1.55 m	1.05 m
Control Unit	0.20 m	0.15 m

Other equipment should be positioned at least 7 m away from a magnetic compass.

SYSTEM CONFIGURATION

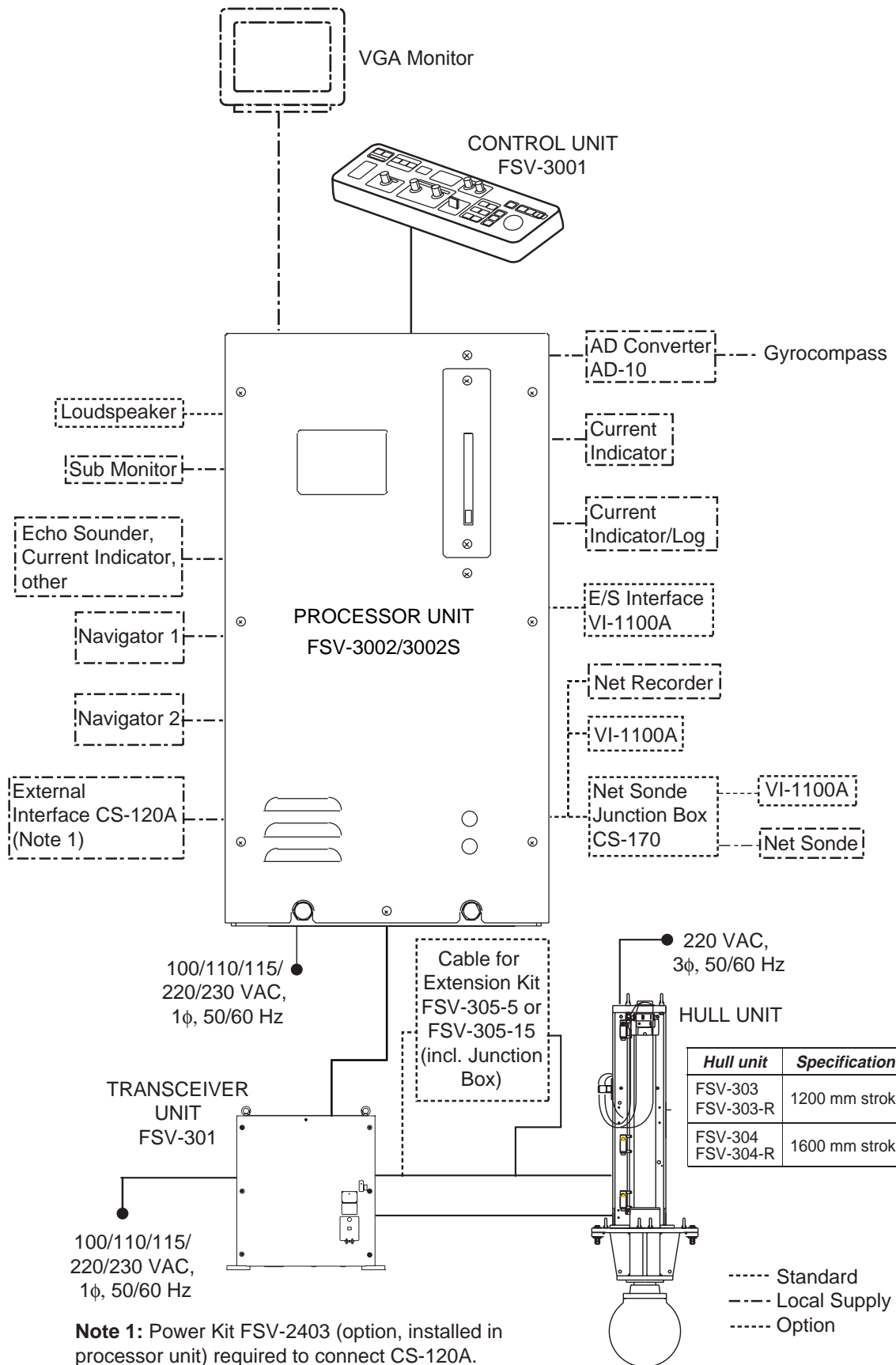

EQUIPMENT LISTS

Standard supply

Name	Type	Code No.	Qty	Remarks
Control Unit	FSV-3001	—	1	With cable
Processor Unit	FSV-3002	—	1	For FSV-30
	FSV-3002S	—		For FSV-30S
Transceiver Unit	FSV-301	—	1	
Hull Unit	FSV-303/303-R	—	1	1200 mm stroke
	FSV-304/304-R	—		1600 mm stroke
Installation Materials	CP10-06000	000-144-389	1 set	Signal cable 10S2078 (between transceiver unit and hull unit, 8 m)
	CP10-06201	007-008-540	1 set	For transceiver unit. See packing list.
	CP10-06100	000-067-067	1 set	For processor unit CP10-04502, CP10-04506. See packing list.
Spare Parts	SP10-03101	007-008-530	1 set	For transceiver unit. See packing list.
	SP10-02601	006-921-340	1 set	For processor unit. See packing list.
	SP10-02603	006-921-360	1 set	For processor unit
Accessories	FP10-02901	007-008-780	1 set	For processor unit
	FP10-02201	006-922-390	1 set	For control unit

Optional Equipment

Name	Type	Code No.	Qty	Remarks
Control Unit	FSV-3001	—	1	
37-core Cable	10S1258	001-113-000-10	1	Specify length
E/S Interface	VI-1100A	—	1	
Net Sonde Junction Box	CS-170	—	1	
Power Supply Kit	FSV-2403	000-067-013	1	For connection of CS-120A
NMEA Cable	MJ-A6SPF0012-100C	000-154-037-10	1	10 m, NMEA, 6P-6P
	MJ-A6SPF0012-050C	000-154-053-10	1	5 m, NMEA, 6P-6P
8-core Cable	VVS 0.3×8C *6M*	000-555-043	1	6 m, for echosounder, 02S8040
Attachment Flange	OP10-27	000-067-050	1	
Attachment Kit	OP10-24	006-943-530		
Loudspeaker	SEM-21Q	000-144-917	1	
Installation Materials	CP10-04801	006-934-240	1	See back of manual for details.
Cable Extension Kit	FSV-305-5	000-067-072	1	Junction box, 10S2240, 10S2144
	FSV-305-15	000-067-073		Junction box, 10S2240, 10S2145
Data Recording Kit	OP10-31	000-017-095	1	
Calibration Ball	OP10-33	000-017-096	1	φ 38.1
	OP10-34	000-017-097	1	φ 47.625

1. MOUNTING THE EQUIPMENT

NOTICE

Do not apply paint, anti-corrosive sealant or contact spray to coating or plastic parts of the equipment.

Those items contain organic solvents that can damage coating and plastic parts, especially plastic connectors.

1.1 Hull Unit

Note 1: The raise/lower control box on the hull unit contains a motion sensor. Therefore, never drop the hull unit.

Note 2: Handle the transducer carefully. Shock will damage its sensitive components.

1.1.1 Mounting considerations

Decide the location of the hull unit through consultation with the dockyard and ship owner. When deciding the location, the following points should be taken into account.

- Choose an area where propeller noise, cruising noise, air bubbles and interference from turbulence are at a minimum. Generally, the point at $1/3$ to $1/2$ of the ship's length from the bow on or near the keel is optimum. On-the-keel installation is advantageous for minimizing oil consumption in comparison with off-the-keel. If the hull unit can not be installed on the keel, the center of the retraction tank should be within 600 mm of the keel to prevent a rolling effect. **For large ship with deep draft**, the hull unit can be installed at the bow.

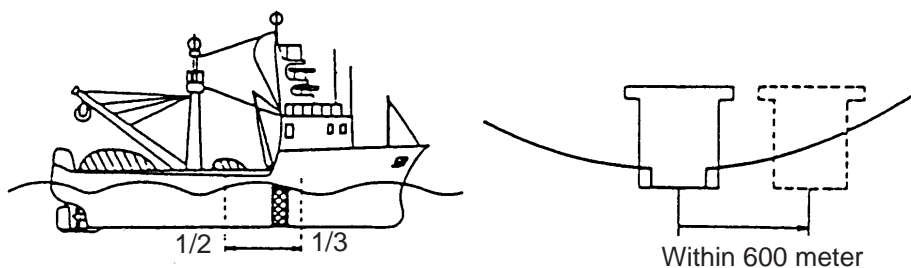

Hull unit mounting location

- Choose a place where the hull bottom is flat and the draft is sufficiently deep. Normally, the transducer should protrude at least 500 mm beyond the keel to minimize the effect of air foam and bubbles.
- Choose a place where interference from other transducers is minimal. The hull unit should be at least 2.5 m away from the transducers of other equipment.

- No obstacle should be in the fore direction since it causes a shadow zone and aerated water, resulting in poor sonar performance.
- The physical distance between the hull unit and the transceiver unit should be no more than 5 m.
- The space shown in the figure on the next page is required around the hull unit for wiring and maintenance.
- If the ambient temperature around the unit will be below 0°C, provide the sonar compartment with a heater to keep the temperature above 0°C.

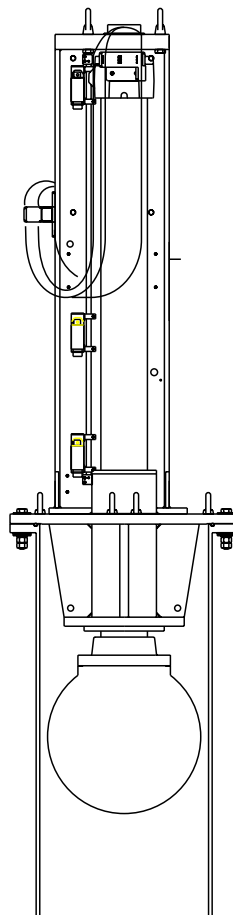
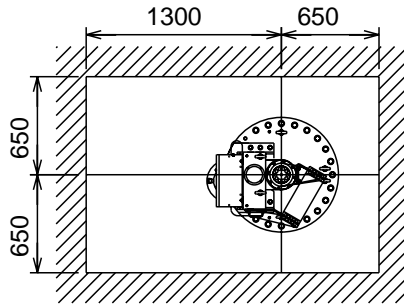

Maintenance space, example sonar compartment

Note: After mounting the equipment, install anti-vibration stays, referring to page 1-7.

1.1.2 Shortening the retraction tank

The retraction tank is 1300 mm in length when supplied. Shorten the tank as necessary so that the transducer positions well below the keel when it is fully lowered. The following table provides guidelines for shortening the tank. Refer also to the retraction tank installation drawing at the back of this manual.

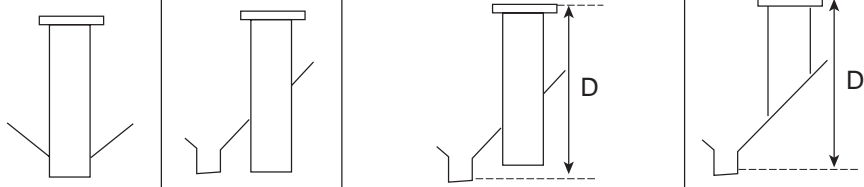
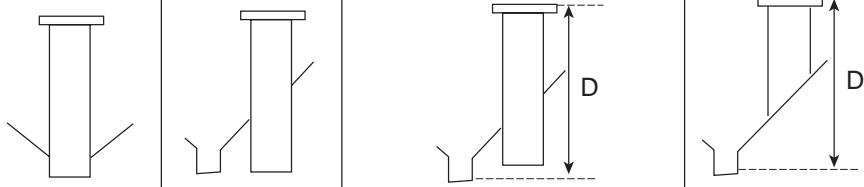
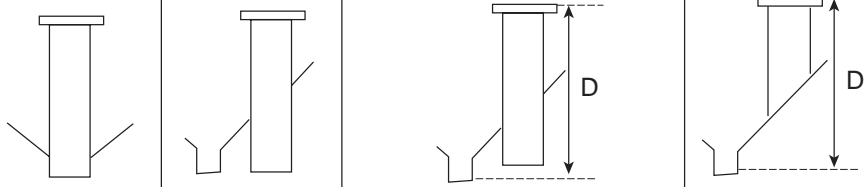
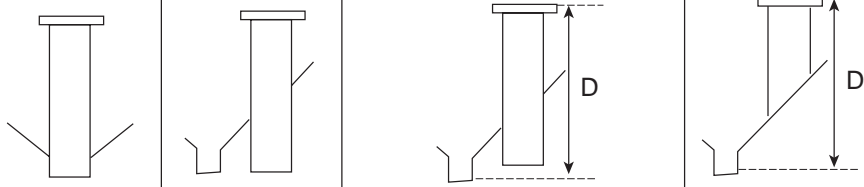
Installation Method				
XDCR Travel				
1200 mm stroke	Remove 280 - 290 mm from the bottom.	Same as left.	Remove 280 - 290 mm from the bottom. Note that the length "D" must be less than 1170 mm.	Same as left.
1600 mm stroke	Remove less than 290 mm from the bottom.	Same as left.	Remove less than 290 mm from the bottom. Note that the length "D" must be less than 1570 mm.	Same as left.

Guidelines for shortening the retraction tank

- Note 1:** For the 1200 mm stroke hull unit, the transducer will not fully protrude unless the tank is shortened by at least 280 mm from the bottom, and cannot be fully retracted if more than 290 mm is removed.
- Note 2:** For the 1600 mm stroke hull unit, the transducer cannot be fully retracted if the tank is removed more than 290 mm.
- Note 3:** When 290 mm is removed and "D" is minimum, the effect of air foam is minimized because the transducer fully protrudes in water.

1.1.3 Remarks for installation of retraction tank

1. Make, if possible, the installation location a double bottom structure.
2. Install, if possible, the tank on the keel where the tank can be most firmly fixed.
3. Install the reinforcement ribs as near as possible to the top of the retraction tank, allowing space for tightening of nuts and bolts.

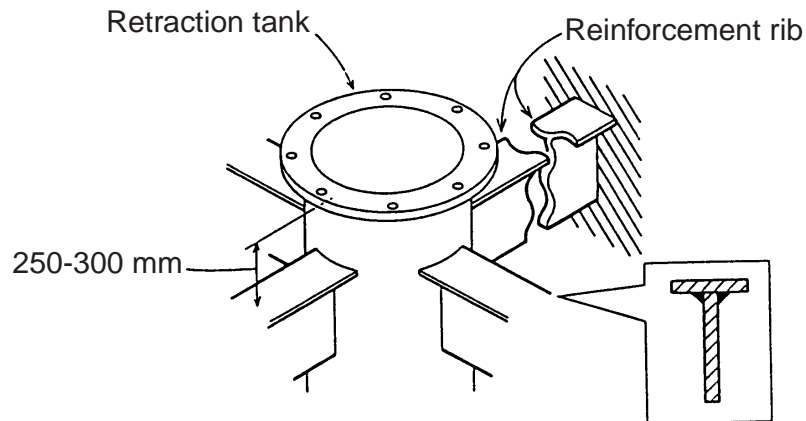

How to install reinforcement ribs

4. Add a doubling plate (a plate added to another to give extra strength or stiffness) at the location where the retraction tank is welded to the hull bottom. The size of the doubling plate is normally 1300 mm in diameter so that it may lie across two bottom frames.
5. Use a chisel to inscribe the bow mark on the attachment flange.

1.1.4 Installing hull unit on retraction tank

After welding the retraction tank and allowing sufficient time for cooling, install the hull unit as follows:

1. Clean the hull unit flange, the O-ring and O-ring groove. Coat them with a slight amount of grease. Place the O-ring in position on the tank flange.
2. Orient the hull unit so that the bow mark (inscribed) on its flange points toward the ship's bow. Note that heading adjustment is required if the bow mark is not facing the ship's bow.
3. Confirm that the O-ring is in position. Place the hull unit on the tank.
4. Coat every washer, nut and bolt with a slight amount of grease to ease removal. Fasten the hull unit to the retraction tank with flat washers, spring washers and hex bolts.
5. Reinforce the hull unit against vibration by extending stays to the ship's hull from the two eye bolts at the top of the hull unit, referring to the procedure on page 1-7.

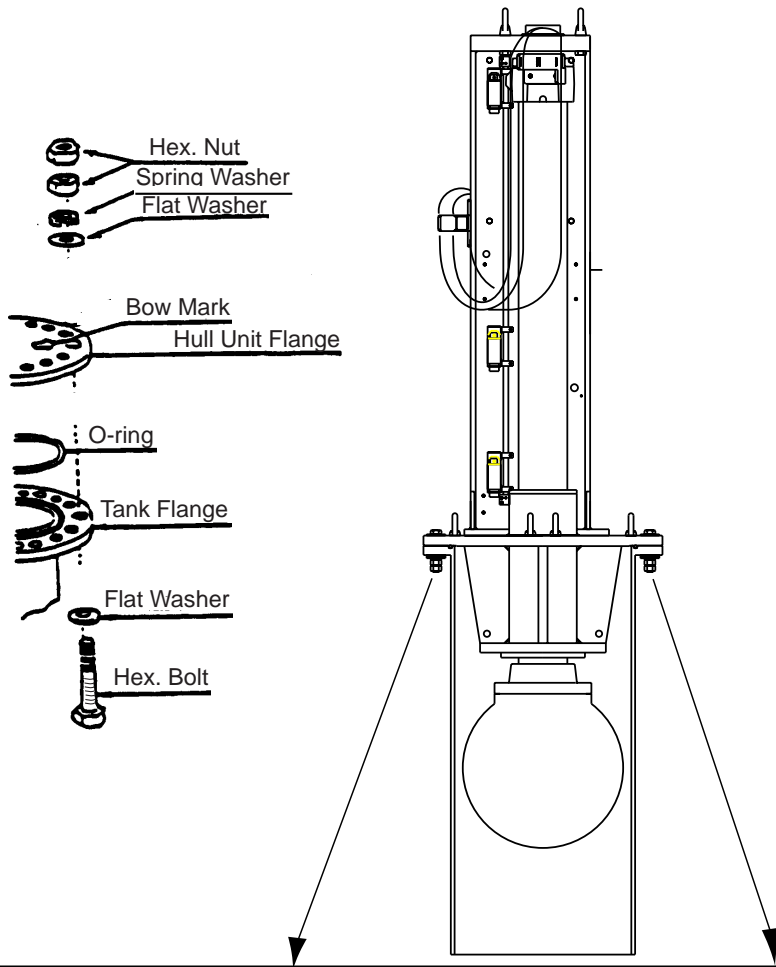

- Hex. Nut
- Spring Washer
- Flat Washer

- Bow Mark
- Hull Unit Flange

- O-ring
- Tank Flange

- Flat Washer
- Hex. Bolt

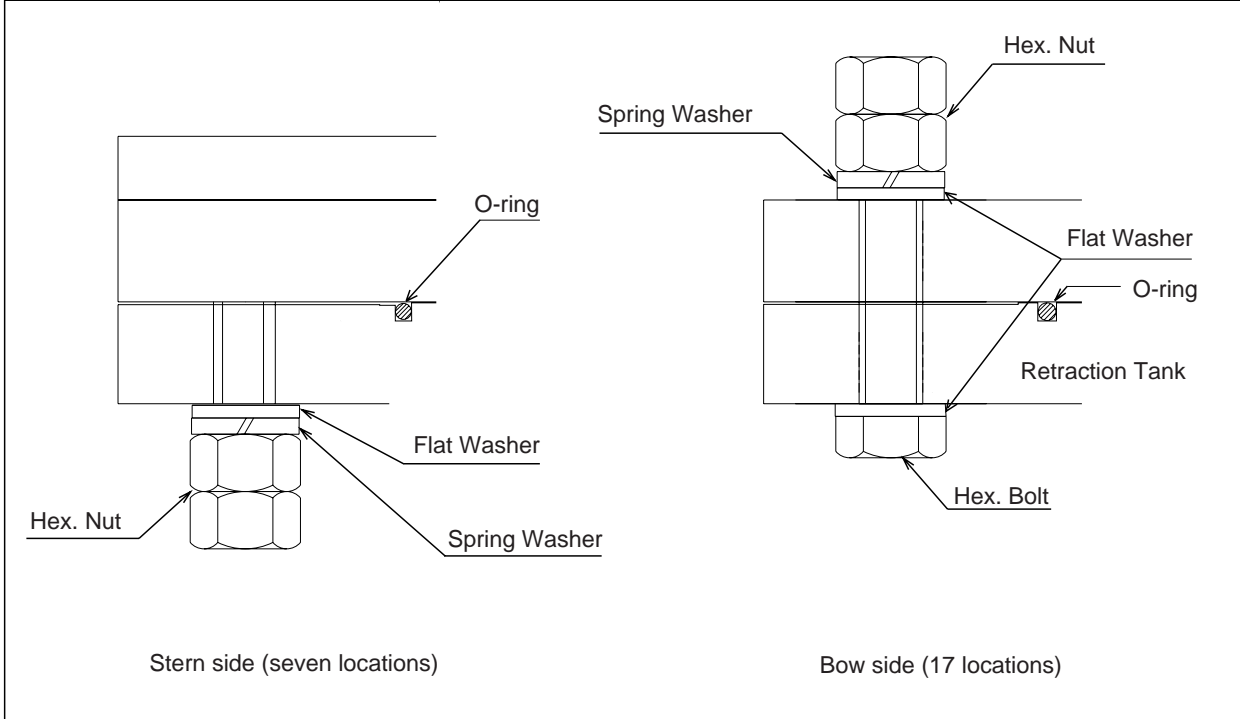

- O-ring
- Flat Washer
- Spring Washer
- Hex. Nut

- Hex. Nut
- Spring Washer
- Flat Washer
- O-ring
- Retraction Tank
- Hex. Bolt

Stern side (seven locations)

Bow side (17 locations)

Installation of hull unit

1.1.5 Installing stays (anti-vibration measure)

Install stays from the top of the hull unit to the ship's hull. The stays should be angle iron with a size of 75×75×9 mm or more and at least two pieces should be used; one each to ship's bow and stern directions. Install if possible, two more stays in ship's transverse direction. **This measure must be done to prevent damage to the transducer.**

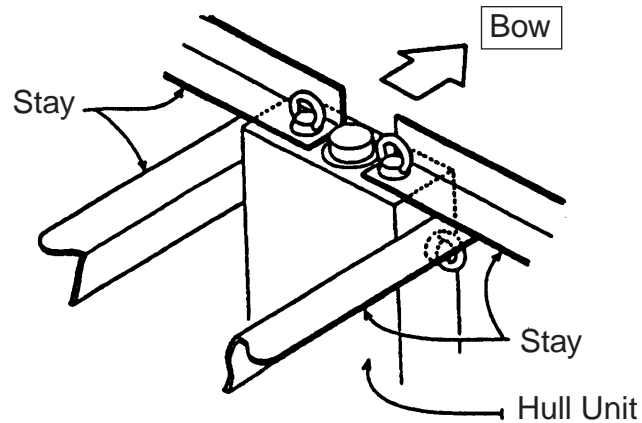

Proper installation of stays

Do not install the stays on a crossbeam on an overhead. Vibration-resistance effect is reduced since vibration is applied to the stays as rotation force. Install them horizontally.

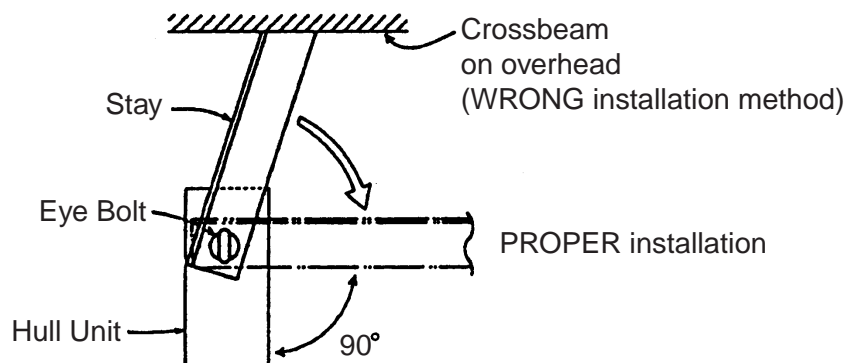

Proper and improper stay installation methods

1.2 Processor Unit

Mounting considerations

When choosing a mounting location, keep in mind the following points:

- The processor unit must be mounted upright.
- Locate the unit out of direct sunlight and away from heat sources because of heat that can build up inside the cabinet.
- Do not locate the equipment where it may be subjected to water splash or rain.
- Be sure the mounting location is strong enough to support the weight of the unit under the continued vibration which is normally experienced on the ship. If necessary reinforce the mounting location.
- Determine the mounting location considering the length of the cables below.
 - Signal cable from the transceiver unit
 - Control cable from the control unit (when locally supplied monitor is used)
- Leave sufficient space on the sides and rear of the unit to facilitate maintenance. Also, leave a foot or so of "service loop" in cables behind the unit so it can be pulled forward for servicing or easy removal of connectors.
- Make free space of 400 mm between the processor unit and bulkhead to prevent cable stress.
- Observe the compass safe distances shown on page ii to prevent interference to a magnetic compass.

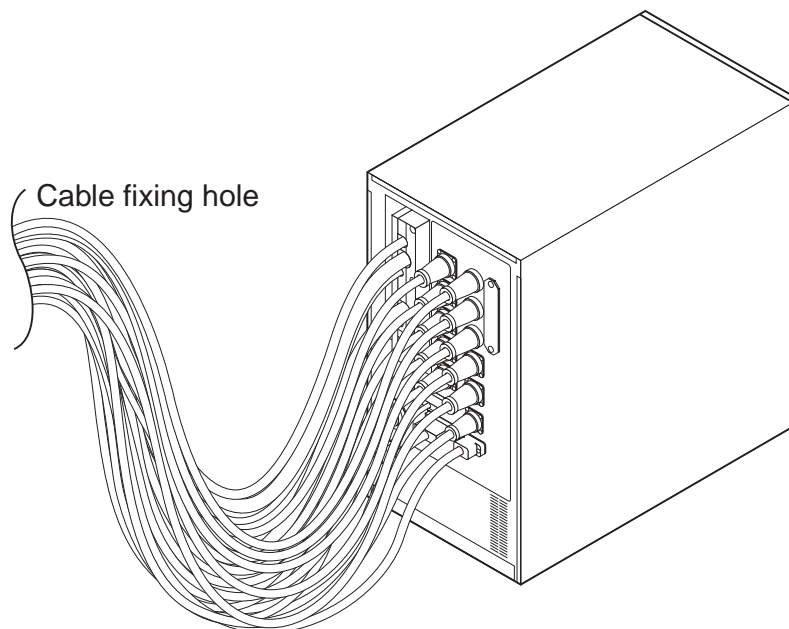

Processor unit, rear view

Mounting procedure

1. Unfasten two bolts from the bottom of the front side of the processor unit. Pull the unit toward you to separate it from the mounting base.
2. Use six bolts (M6×20, supplied as installation material) to fix the mounting base.
3. Place the processor unit in front of the mounting base.
4. Push the unit forward until it touches the end of the mounting base.
5. Refasten two bolts removed at step 1 to fix the unit to the mounting base.

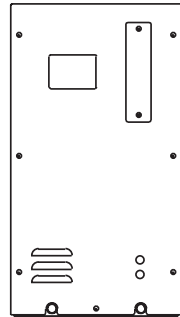

Front view

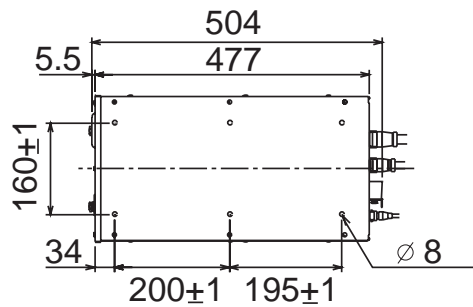

*Top view
Processor unit*

1.3 Control Unit

The control unit may be mounted on a tabletop with or without the KB (keyboard) fixing plate (supplied), which mounts the control unit at an angle. If the control unit is not to be fixed permanently, lay it atop the rubber feet (supplied as accessories). Be sure to observe the compass safe distances noted on page ii to prevent interference to a magnetic compass.

(1) Rubber feet

Attach four rubber feet to the bottom of the control unit if it is not going to be permanently fixed.

(2) Mounting without KB fixing plate

1. Drill four mounting holes of 6 mm diameter to fasten the control unit, referring to the outline drawing at the back of this manual.
2. Referring to the outline drawing for the control unit at the back of this manual, make a cutout in the mounting location large enough to accommodate the name plate so the control unit will lie flat.
3. Fix the control unit with four bolts (M5) from under the tabletop. (M5 bolts with a sufficient length for the thickness of the tabletop should be provided locally.)

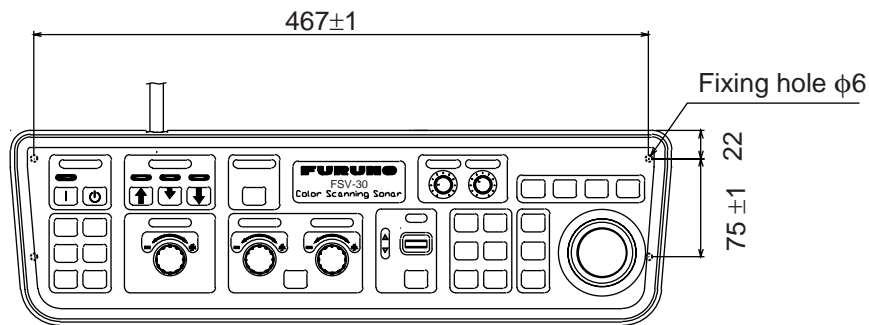

Control unit

(3) Mounting with KB fixing plate

1. To fix the control unit to a desired location at an angle, fasten the KB fixing plate to the control unit and desired location with two upset screws (M5×10, supplied) and two tapping screws ($\phi 6.5$, local supply) as below.

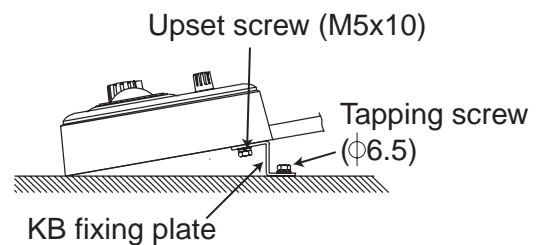
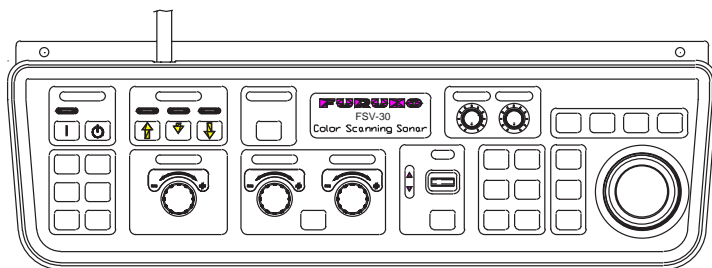

How to attach KB fixing plate

2. Set dust cover (supplied) to the control unit.

Passing the cable through the bottom of the control unit (for permanent mounting)

For permanent mounting methods (2) and (3), the control cable can be passed through the bottom of the control unit as follows:

1. Unfasten eight screws (M4) to remove the cover from the bottom of the control unit.
2. Unscrew two screws (M4×10) to remove the cable clamp.
3. Disconnect two connectors J1 and J2 from the circuit board.
4. Attach the control cable to the control unit cover with the cable clamp (removed at step 2), two flat head screws (M4), flat washers, spring washers and nuts (hardware: supplied).

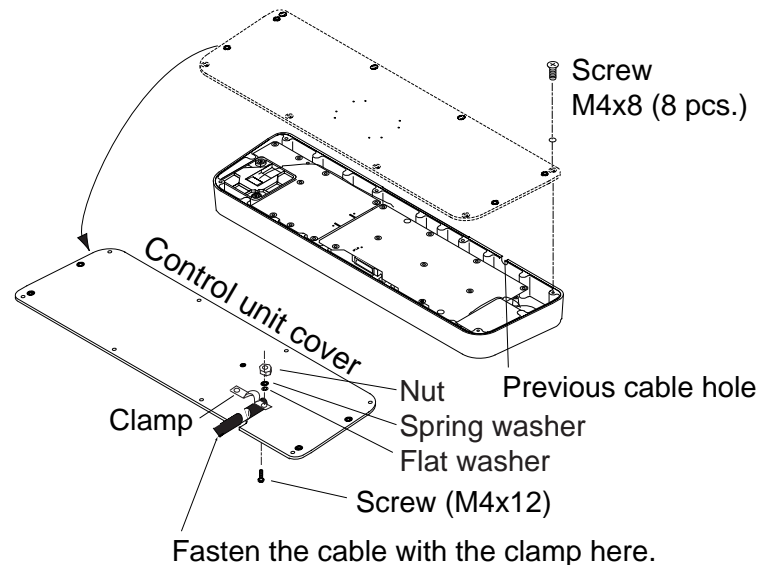

Control unit, cover removed

5. Re-connect two connectors disconnected at step 3.
6. Fasten eight screws to attach the control unit cover.
7. Attach the connector seal (supplied) to the hole at the rear of the control unit.
8. Drill a hole of 30 mm in diameter to pass the cable from the bottom of the control unit through the tabletop
9. Attach the connector seal (supplied) to the hole at the bottom of the control unit when the above modification is not done.
10. Fix the control unit referring to (2) or (3) on the previous page.

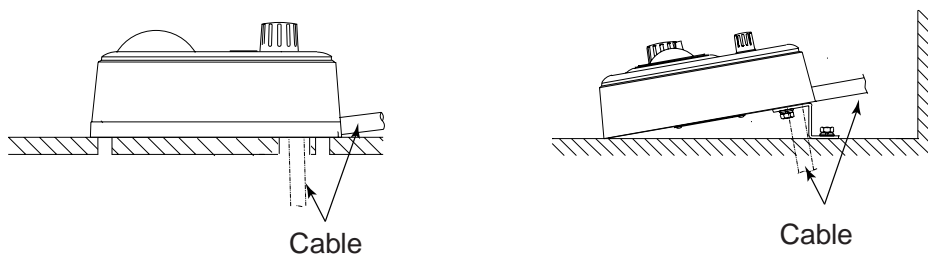

Without KB fixing plate

With KB fixing plate

Control unit, side view

1.4 Transceiver Unit

The physical distance between the hull unit and the transceiver unit should be no more than 5 m. The transceiver unit should be mounted on a mounting base (shipyard supply) whose dimensions are as shown in the outline drawing of the transceiver unit at the back of this manual. Reinforce the transceiver unit against vibration by stays extending from the eyebolts on the top of the unit. Fasten four bolts (M12, local supply) at the bottom of the transceiver unit to fix the unit to the mounting location.

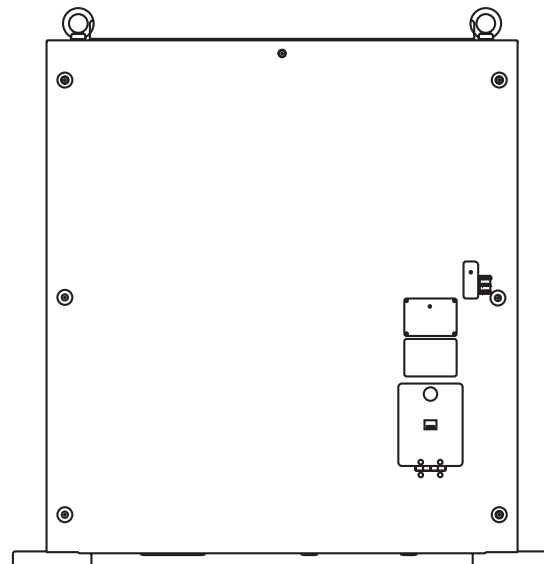

Transceiver unit

1.5 Grounding the Equipment

Transceiver unit, junction box: Use copper strap (supplied).

Processor unit: Use a ground wire (IV-8SQ).

Junction box for hull unit: Use the wing bolt on the junction box.

1.6 Installing the Attachment Flange (option)

The attachment flange permits use of the tank for the CSH-20 series using the 1200 mm stroke transducer.

Attachment flange Type: OP10-27, Code no: 000-067-050)

Name	Type	Code No.	Qty	Remarks
Attachment flange	10-077-5802	100-303-610	1	
O-ring	CO 0318A (V585)	000-166-370-10	1	
Hex. nut	M20 SUS304	000-863-116	48	
Flat washer	M20 SUS304	000-864-136	24	
Spring washer	M20 SUS304	000-864-270	24	

Procedure

1. Clean the hull unit flange, O-ring and O-ring groove. Coat them with a slight amount of grease.
2. Use 48 hex. nuts, flat washers and spring washers to fasten the attachment flange to retraction tank.
3. Place the O-ring in position on the attachment flange.

To install the attachment flange and the hull unit, see paragraph 1.1.4.

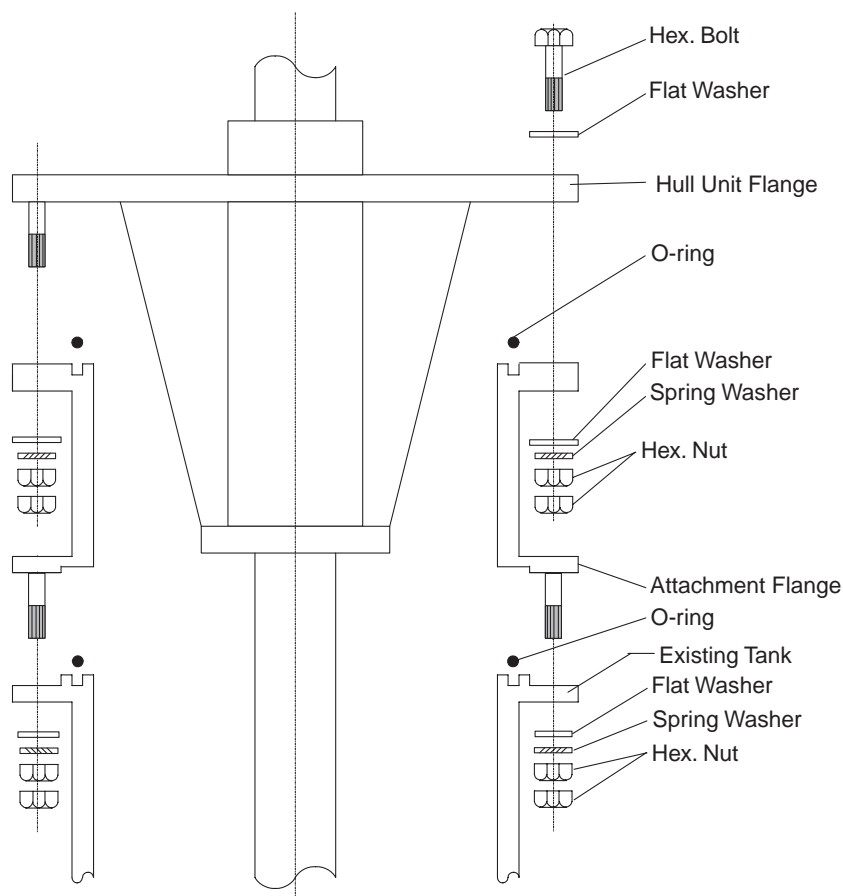

Attachment flange for 1200 mm stroke transducer, sectional view

1.7 Cable Extension Kit (option)

For extension of the transducer cable between the hull unit and the transceiver unit, use the cable extension kit (option), which includes a junction box. The kit is available in 5 m or 15 m extension lengths. Below are the contents of each kit.

Name: Cable Extension Kit, Type: FSV-305-5, Code No.: 000-067-072

Name	Type	Code No.	Qty	Remarks
Junction box	FSV-305	000-067-032	1	
Cable assembly	10S2240	000-148-369-03	1	5 m
	10S2144	000-145-360	1	12.9 m

Name: Cable Extension Kit, Type: FSV-305-15, Code No.: 000-067-073

Name	Type	Code No.	Qty	Remarks
Junction box	FSV-305	000-067-032	1	
Cable assembly	10S2240	000-148-370-03	1	15 m
	10S2145	000-145-361	1	22.9 m

Fasten the junction box to a bulkhead with 4 bolts (M6, local supply).

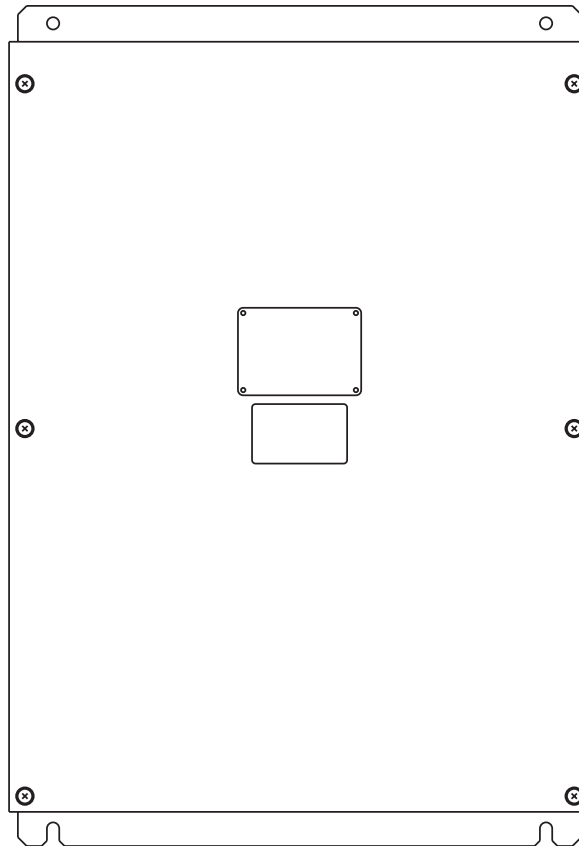

Junction box

1.8 Installing the Attachment Kit (option)

The attachment kit permits use of the tank for the CSH-20 series using the 1600 mm stroke transducer and FSV-243E/244E.

Attachment kit (Type: OP10-24, Code no.: 006-943-530)

Name	Type	Code No.	Qty
Insulation gasket (1)	MS-1000-67	000-857-220	24
Insulation gasket (2)	MS-1000-68	000-857-221	24

1. Clean the hull unit flange, the O-ring and O-ring groove. Coat them with a slight amount of grease. Place the O-ring in position on the tank flange.
2. Lay the insulation gasket (1) on the top of the tank flange.
3. Orient the hull unit so that the bow mark (inscribed) on its flange points toward the ship's bow. Note that heading adjustment in the monitor is required if the bow mark does not face the ship's bow.
4. Confirm that the O-ring and the insulation gasket (1) are in position.
5. Place the hull unit on the tank.
6. Seven of the 24 bolt holes on the hull unit flange have already been fitted with bolts (stern side). Insert the insulation gasket (2) into the bolt holes of the tank flange to which these seven bolts are fitted.
7. Coat every bolt, washer and nut with a slight amount of grease to ease removal. Fit the insulation gasket (2) into the bolt holes of the tank flange. Fasten the hull unit to the retraction tank with insulation gasket (2), flat washers, spring washers and hex bolts.
8. Reinforce the hull unit against vibration by extending stays to the ship's hull from the two eye bolts at the top of the hull unit, referring to the figure at the top of page 1-8.

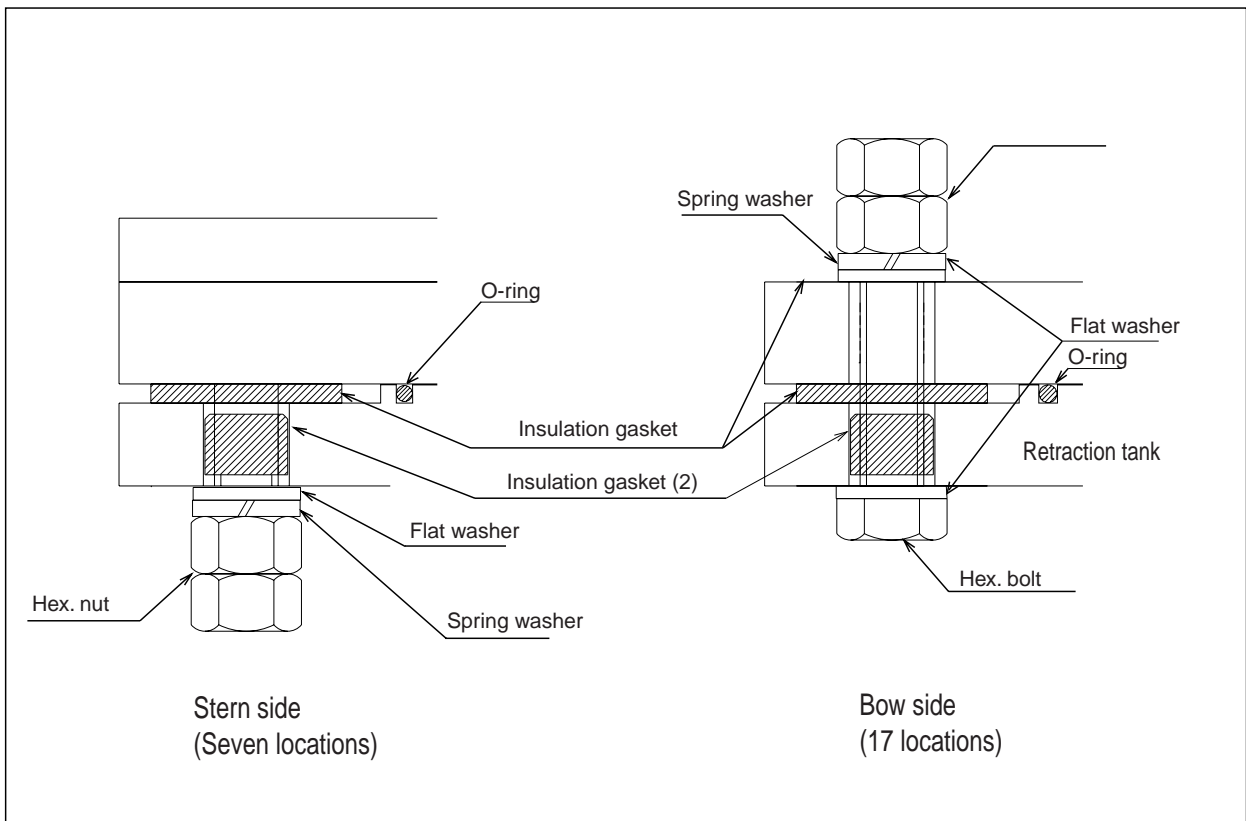
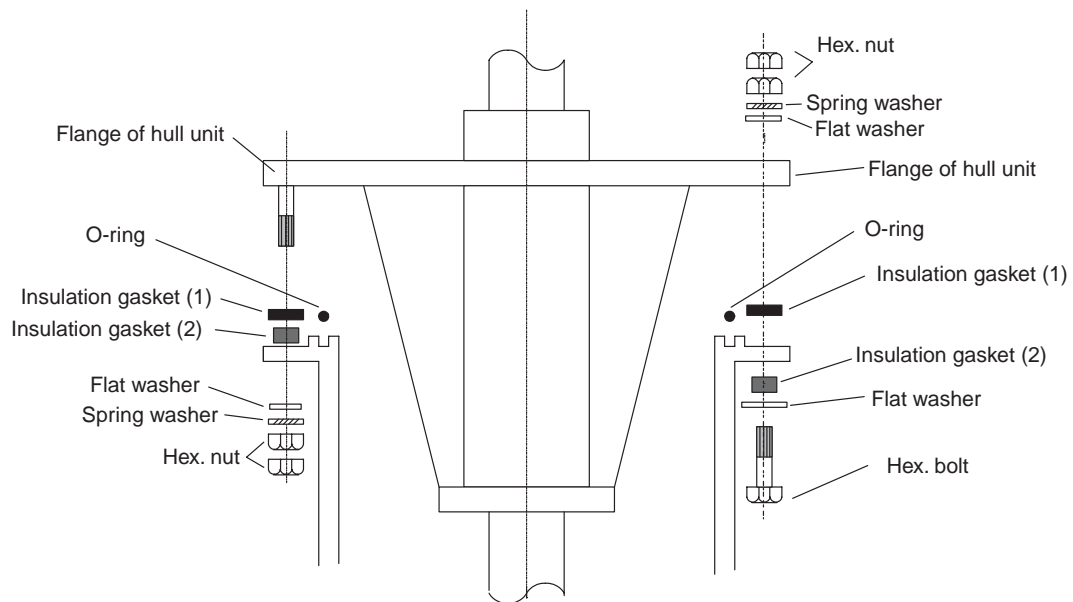

Installation of attachment kit

2. WIRING

2.1 How to Use the Crimping Tool, Pin Extractor

A special crimping tool is necessary for connection of wires to the contact pins of the 38P connector. The pin extractor removes the contact pin from the connector body. This paragraph describes how to crimp and extract the contact pin.



Crimping tool, contact pin, pin extractor

2.1.1 How to use the crimping tool

1. Remove the vinyl sheath by 3 to 4 mm to expose the core.
2. Hold the crimping tool horizontally and insert the contact pin with its slit facing downward into the crimp hole on the crimping tool.
3. Insert the wire onto the contact pin and squeeze the handle until the ratchet releases. (The wire should be placed deep enough into the contact pin so that its end comes in contact with the stopper plate of the crimping tool.) With crimping completed, pull the wire while holding the contact pin to make sure that it is tightly fastened.

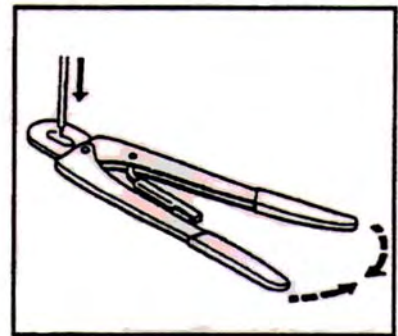

2.1.2 How to use the pin extractor

If a contact pin is inserted into an incorrect hole on the connector body, remove it with the pin extractor.

1. Push the pin extractor into the pin hole from the side opposite to the pin inserting side.
2. Push in the head of the pin extractor. The retaining spring comes free and the contact pin can be removed.

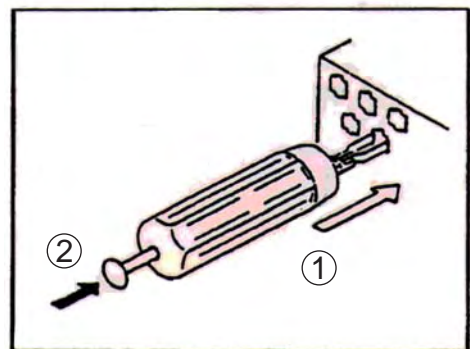

2.2 Wiring

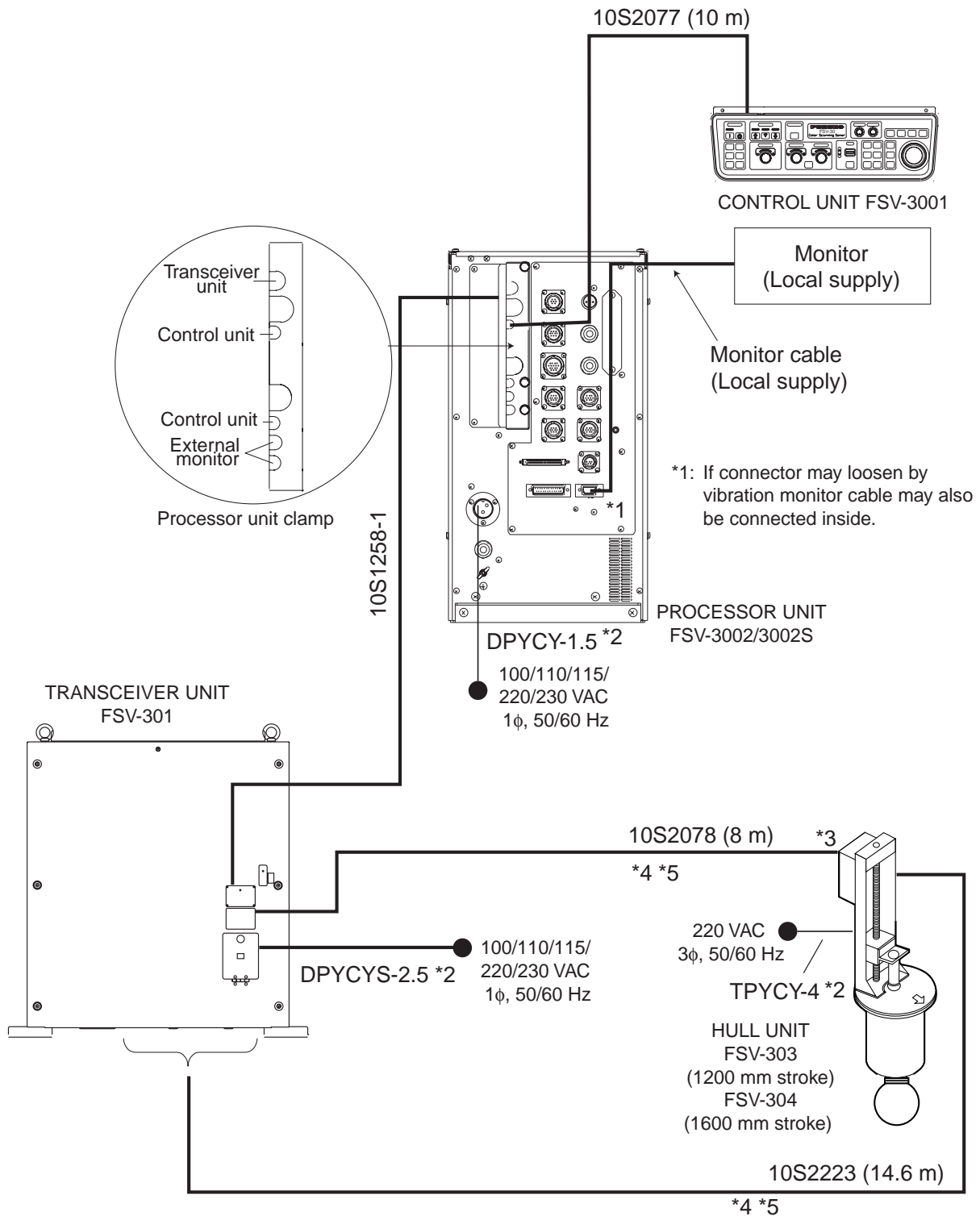

*2: Japan Industrial Standard cable

*3: The same type of connector is fitted at each end, however the connector where the amount of sheath removed is greater should be connected to the transceiver unit.

*4: When running the cables of 10S2078, 10S2223 refer to next page.

*5: When using cable for extension kit, the length of the cable between the transceiver unit and the hull unit is 5 m or 10 m.

Wiring

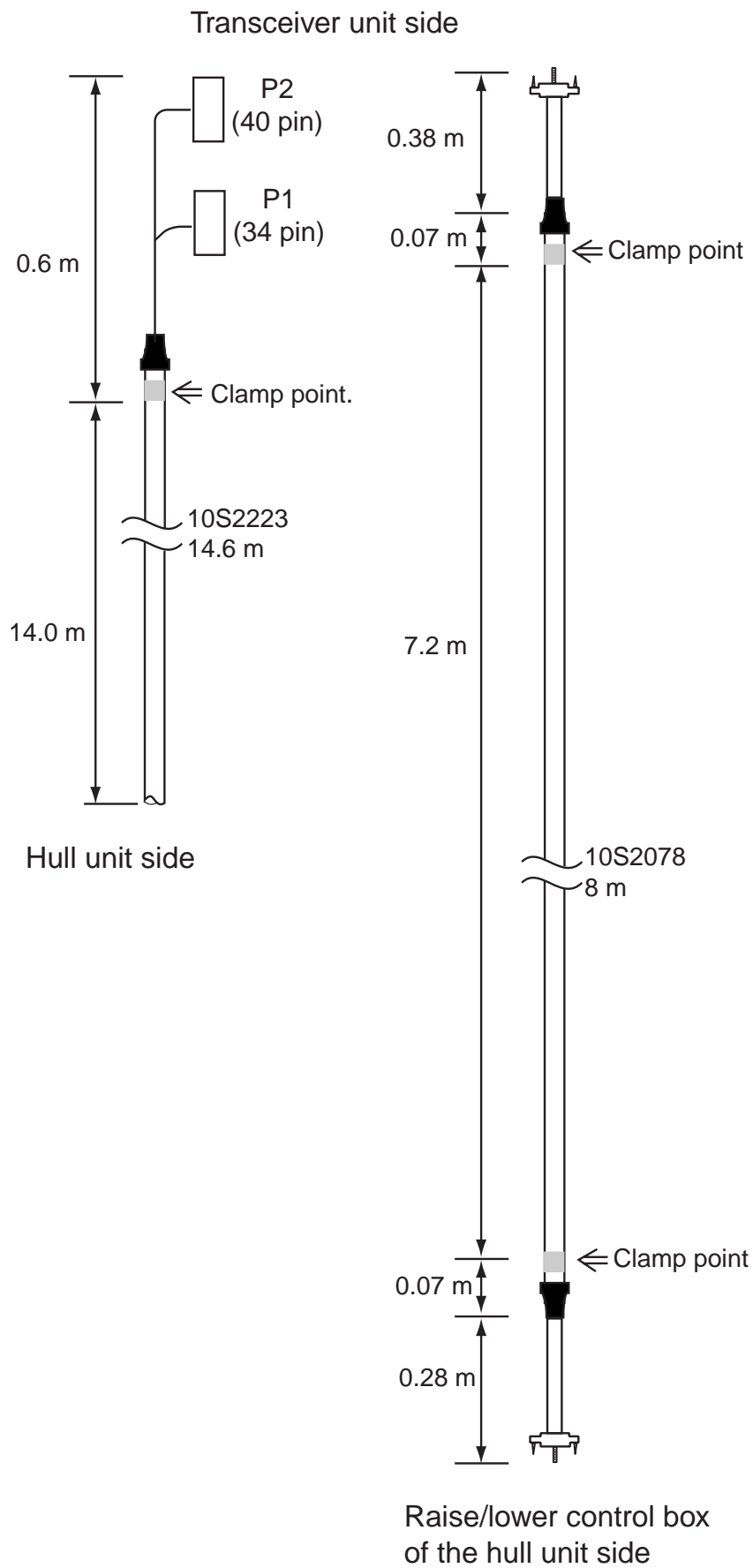

Note that the amount of cable inside the cable clamp on the cable between the hull unit and transceiver unit may be shorted depending on cable length.

2.3 Processor Unit

Cables (10S2074, 10S1258-1 and control cable) from the various units are connected to the CONE Board (10P6905) in the processor unit.

 NOTICE
<p>Divide cables attached to the back of the processor unit between right and left side. Tie each group with a cable tie at the position 15 cm from connectors.</p>
<p>This is necessary to prevent cable stress.</p>

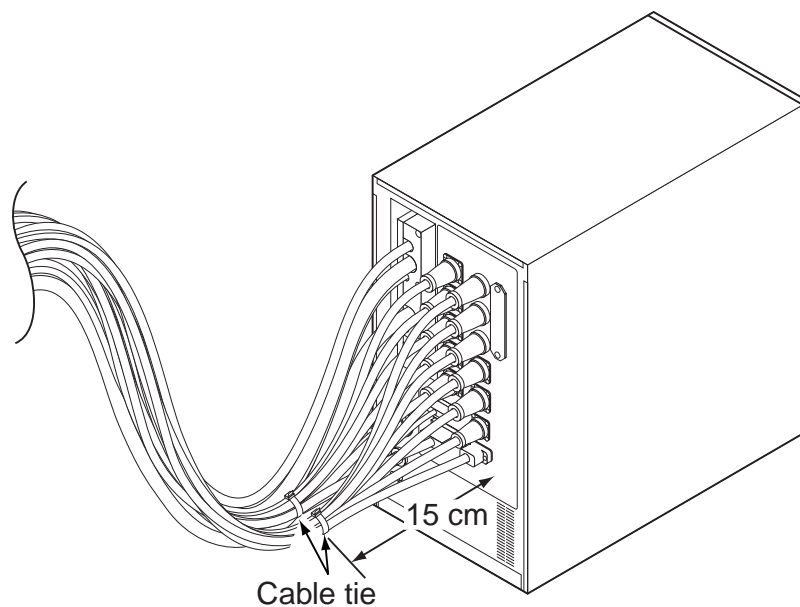

Processor unit, rear view

2.3.1 10S1258-1 cable

This cable runs between the processor unit and transceiver unit.

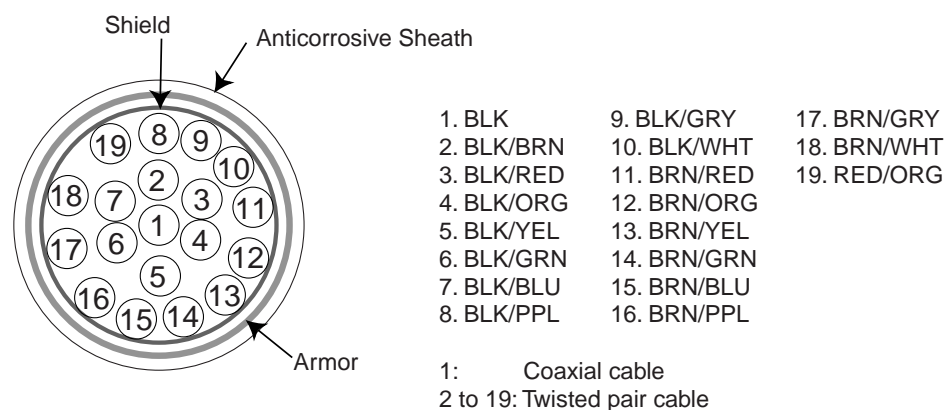

Cable type 10S1258-1, sectional view

Fabrication of connector 00-8016-038-313761HV (CN-A101)

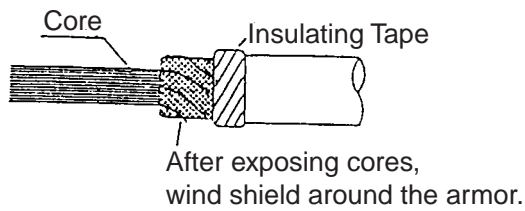
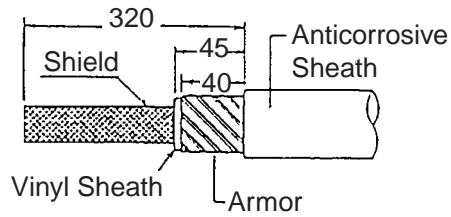

Fabrication of cable for connector 00-8016-038-313761HV

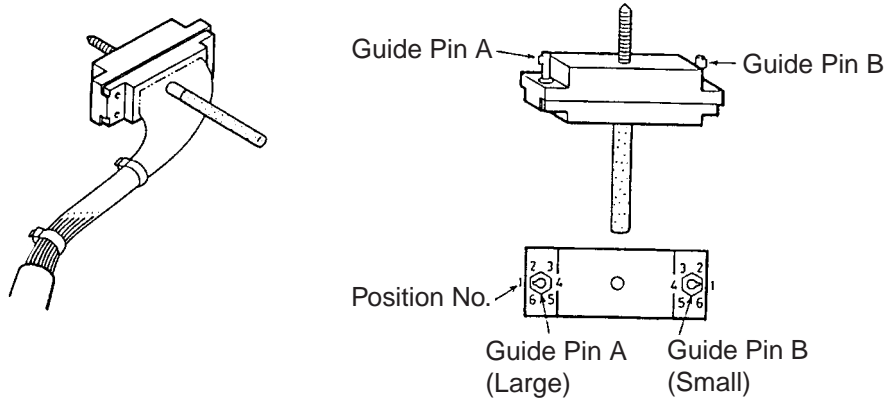

Assembling 38P connector

Positioning guide pins

Guide pins of the connector identify the mating receptacle. They are;

- Guide pin A (Large): 1
- Guide pin B (Small): 1

2.3.2 Power cable

Attach the NCS-253-P connector (CN-A110) to the power cable DPYCY-1.5 (Japan Industrial Standard (JIS) cable) or the equivalent. Attach the connector to the processor unit.

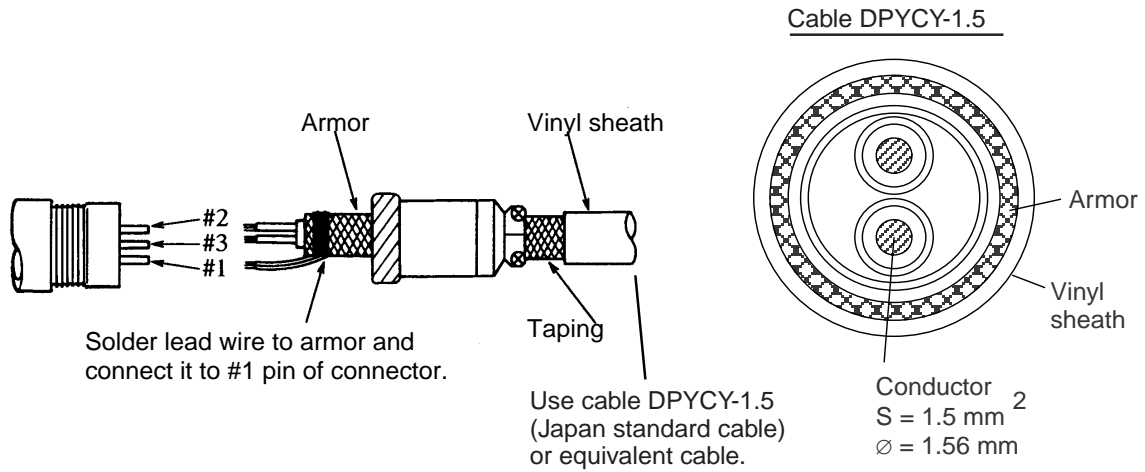

Assembling connector NCS-253-P

2.3.3 Control cable

Attach the control cable (10S2074 or 10S2075) to the CN-A103 connector in the processor unit.

2.3.4 Optional equipment

With connection of a navigator and electronic fishing equipment, the FSV-30 provides true motion presentation, target lock, echo sounder picture, FNZ marker presentation, and digital indication of position, water temperature and depth.

Use the SRCN connectors (optionally supplied, Type: CP10-4801, Code no.: 006-934-240) to connect equipment to the rear of the processor unit. Refer to the interconnection diagram at the back of this manual.

Cable list

Outline of core	
○	Simple
◎	w/shield
∞	Twisted

Sectional view of cables

02S8040

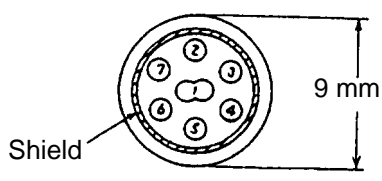

No.	Color
1	WHT/BLU
2	BLK
3	PNK
4	GRN
5	ORG
6	YEL
7	RED

CO-SPEVV-SB-C 0.2sq, 5P

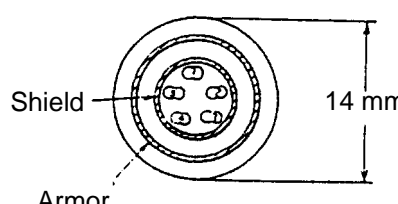

No.	Color
1	YEL/BLK
2	YEL/WHT
3	YEL/RED
4	YEL/BLU
5	YEL/GRN

Cable with armor	J5 (CIF1)	: SRCN6A13-5P
	J7 (GYRO)	: SRCN6A16-10P
	J8 (LOG)	: SRCN6A13-3P
	J10 (FNZ)	: SRCN6A21-10P
	J13 (EXT-KP)	: SRCN6A21-10S

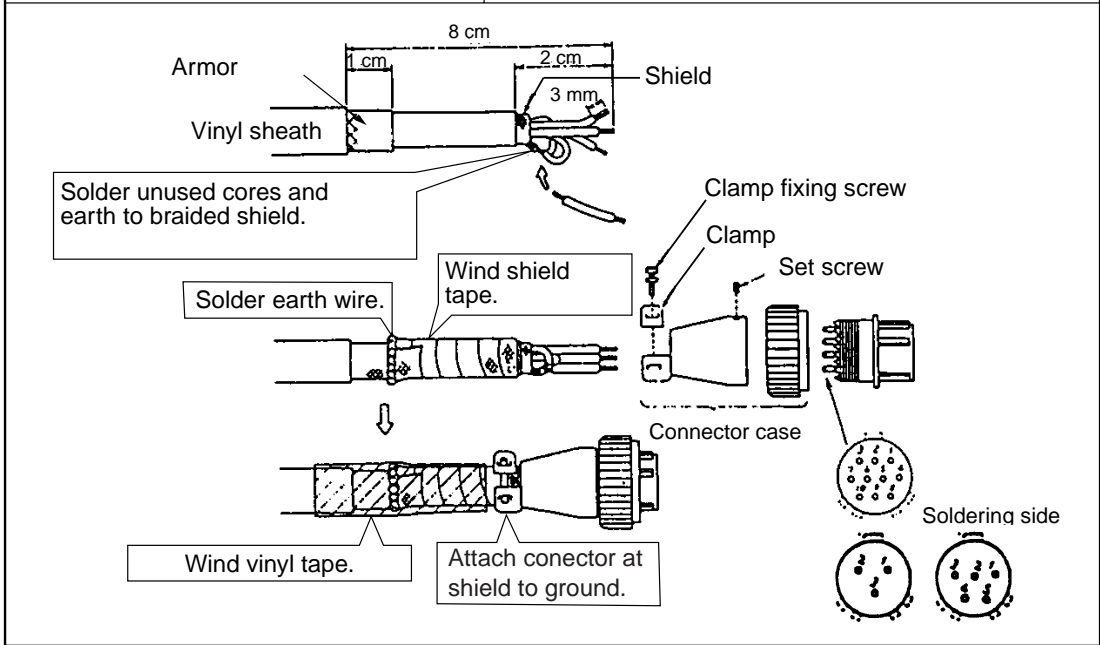

Cable without armor	J9 (ES1)	: SRCN6A16-7P
	J12 (ES2/NET)	: SRCN6A16-10P

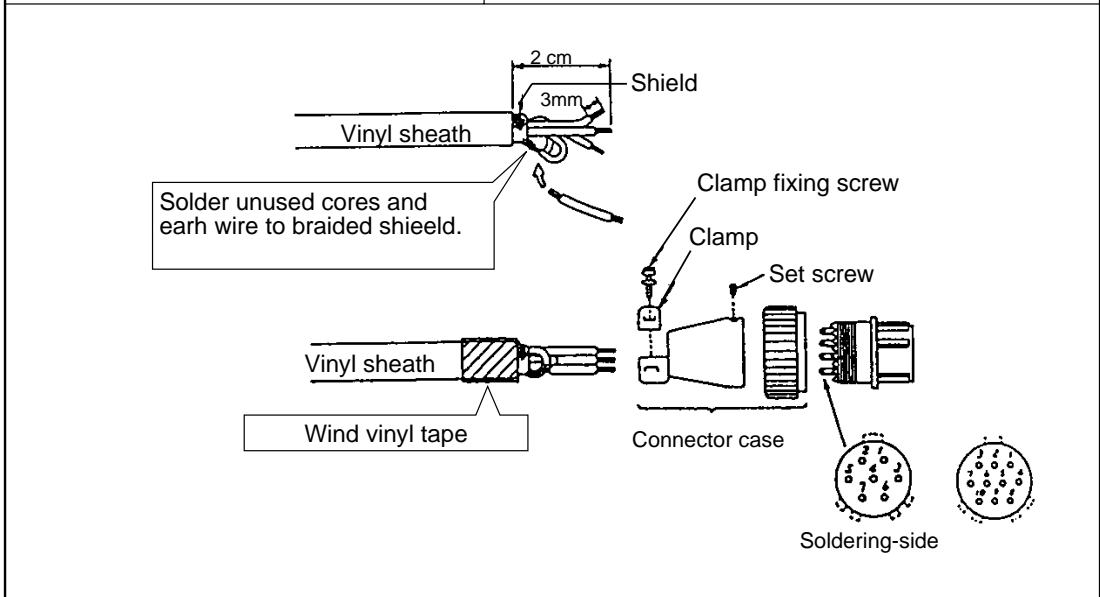

Synchronizing with echo sounder or other sonar

To synchronize the transmission of the FSV-30 with an echo sounder or other type of sonar, make connections as shown below.

For current driven KP input

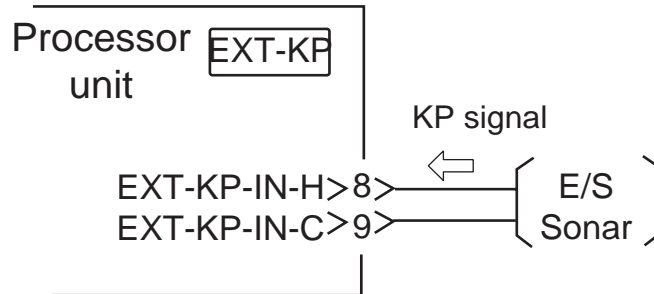

For voltage driven KP (12 V) input

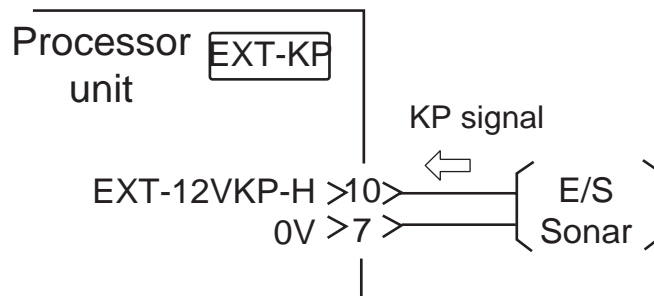

Voltage driven KP output

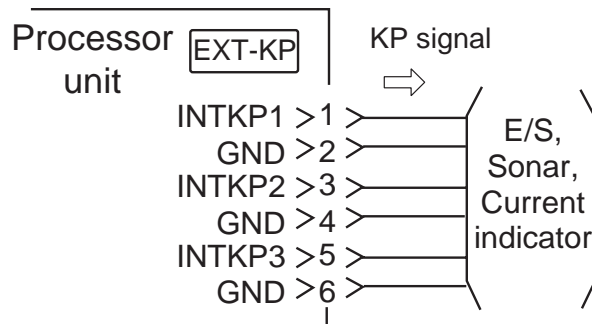

Menu setting

See EXT KP INPUT on page 3-9.

2.4 Transceiver Unit

2.4.1 Fabrication of connector 00-8016-038-313761HV (CN-B101)

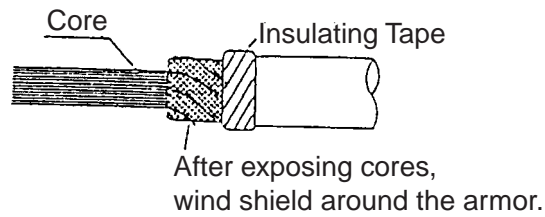
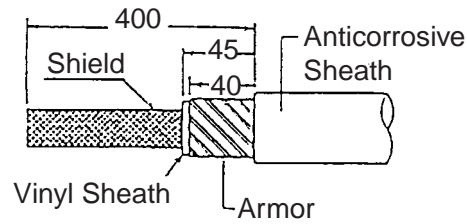

Fabrication of cable for 00-8016-038-313761HV

Shorten the unused wires appropriately and treat their ends with vinyl tape to prevent short circuit.

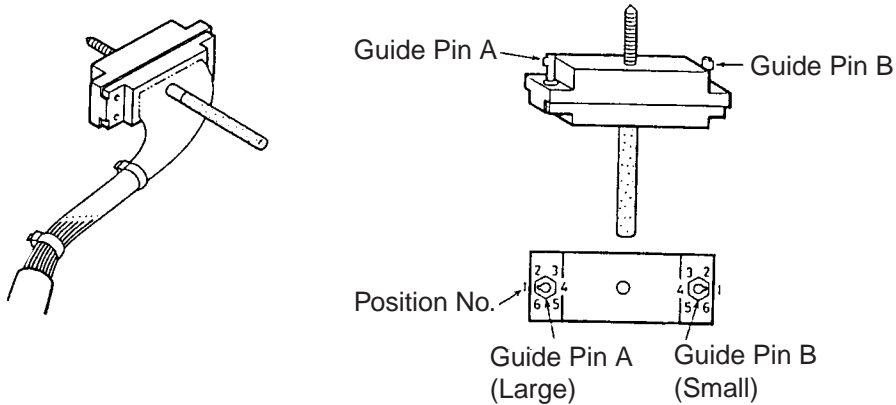

Assembling 38P connector

Positioning guide pins

Use the tool shown below to position guide pins.

Connector	CN-B101	Tool
Guide Pin		
Guide Pin A (large)	1	
Guide Pin B (small)	1	

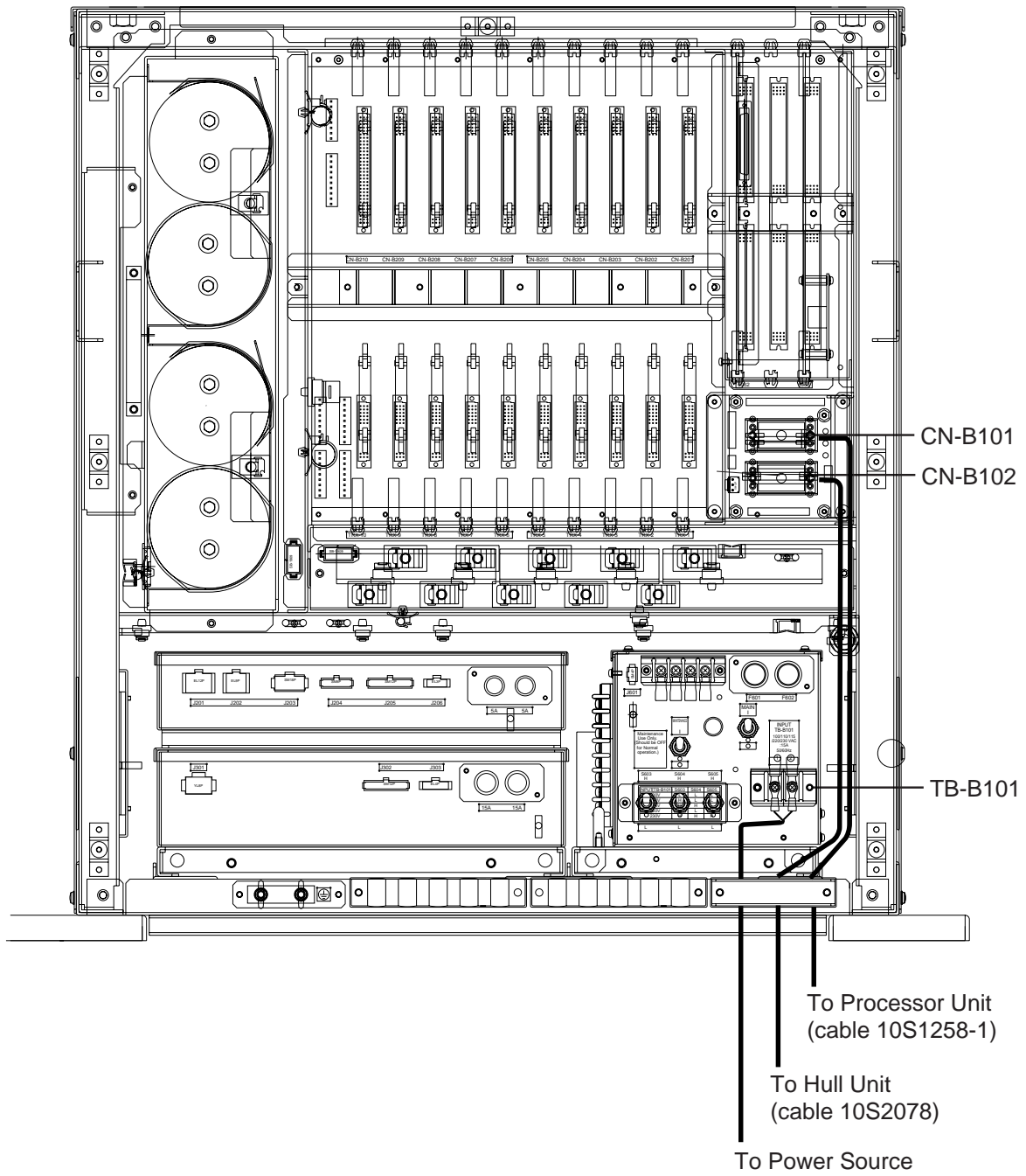

Transceiver unit, inside view

2.4.2 Fabrication of power cable type DPYCYS-2.5 (TB-B101)

Fabricate the cable DPYCYS-2.5 as below for connection to the power source.

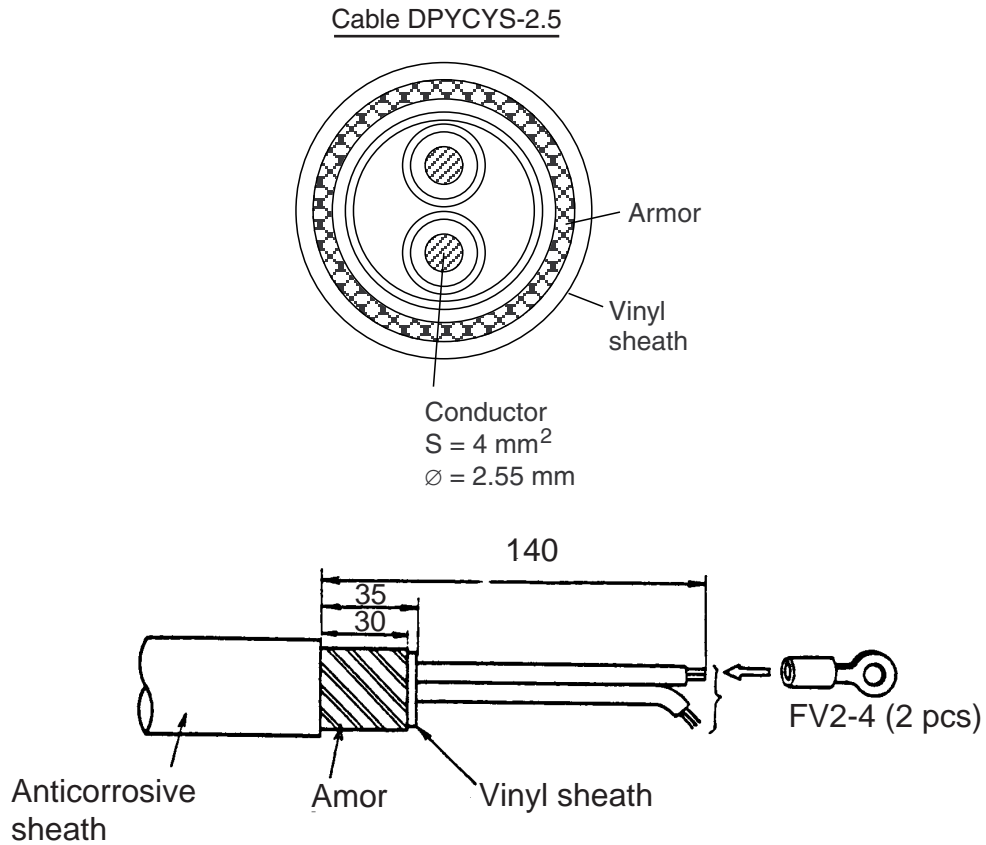

Fabrication of cable type DPYCYS-2.5

2.4.3 Hull control cable (10S2078)

Connect the hull control cable (10S2078) to the CN-B102 in the transceiver unit.

Note: The same type of connector is fitted at each end, however the connector which has a larger portion of its sheath removed should be connected to the transceiver unit.

2.4.4 Wiring in transceiver unit

1. Open the transceiver unit cover.
2. Plug the P1 and P2 connectors at the end of signal cables into the proper receptacles in the transceiver unit, referring to the interconnection diagram at the back of this manual.
3. Lead the signal cables into the transceiver unit appropriately.
4. Fasten the cables with cable clips after wiring the hull unit.

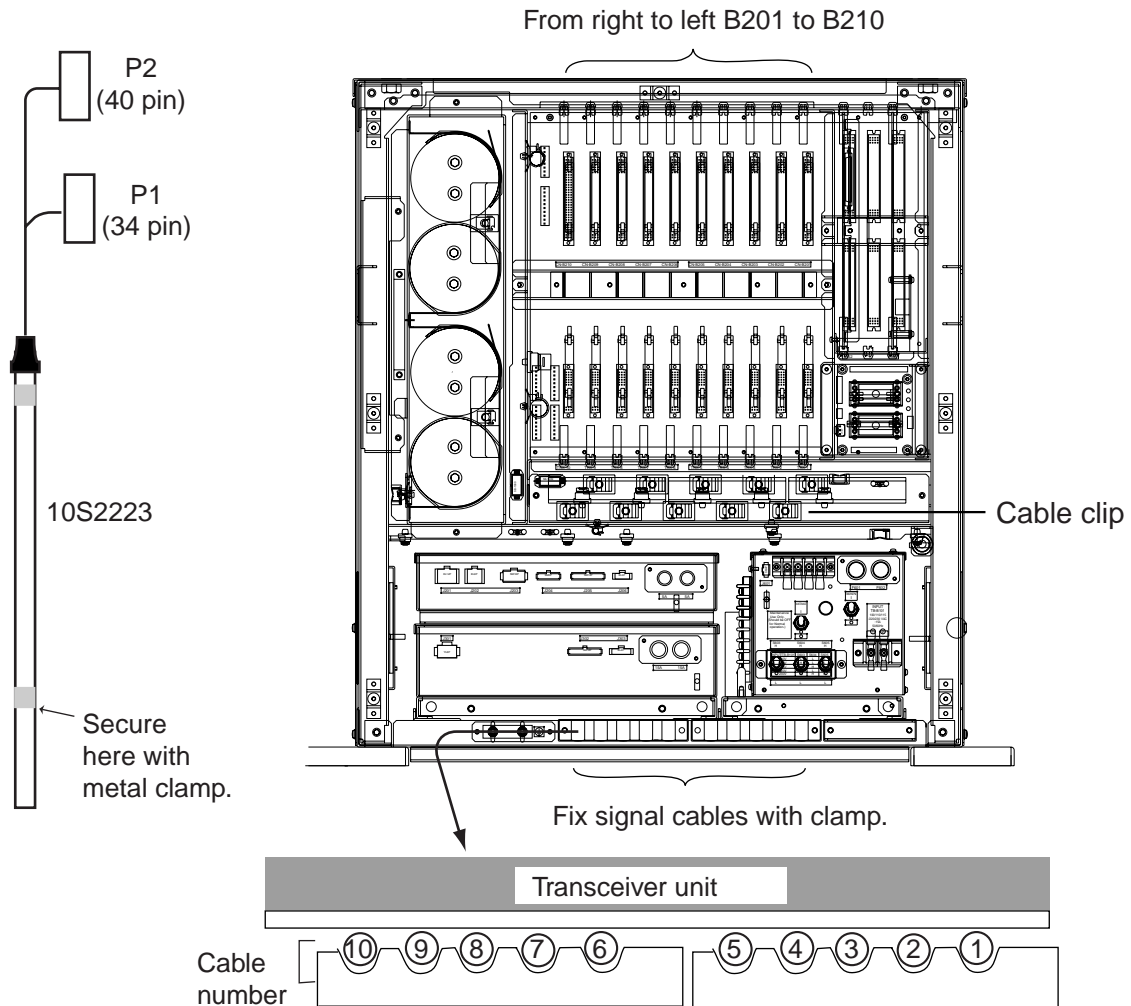

Transceiver unit, top view

2.5 Cable Extension Kit

The length of the cable between the hull unit and transceiver unit is 5 meters. If a longer cable is required, use the cable extension kit, which consists of a junction box and a 5 or 15 meter cable.

Connect the transducer cable 10S2223 to the junction box, and connect the transceiver unit to the junction box with the cable 10S2240 (5 or 10 m).

Replace the cable (10S2078, 8 m) connected between the hull unit and transceiver unit with the cable 10S2144 (12.9 m) or 10S2145 (22.9 m). Those cables are supplied with the extension cable kit.

2.5.1 Junction box

Connect the extension cable 10S2240 to JCTN1 and JCTN2 inside the junction box. Also, connect the transducer cable 10S2223. Refer to interconnection diagram for wiring details.

1. Open the junction box cover.
2. Unfasten the cable clamps.

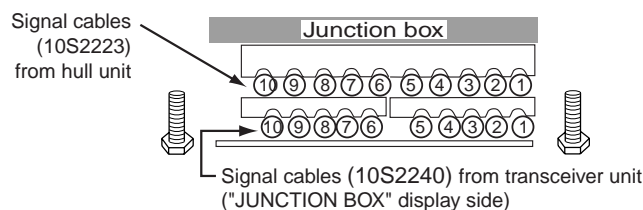
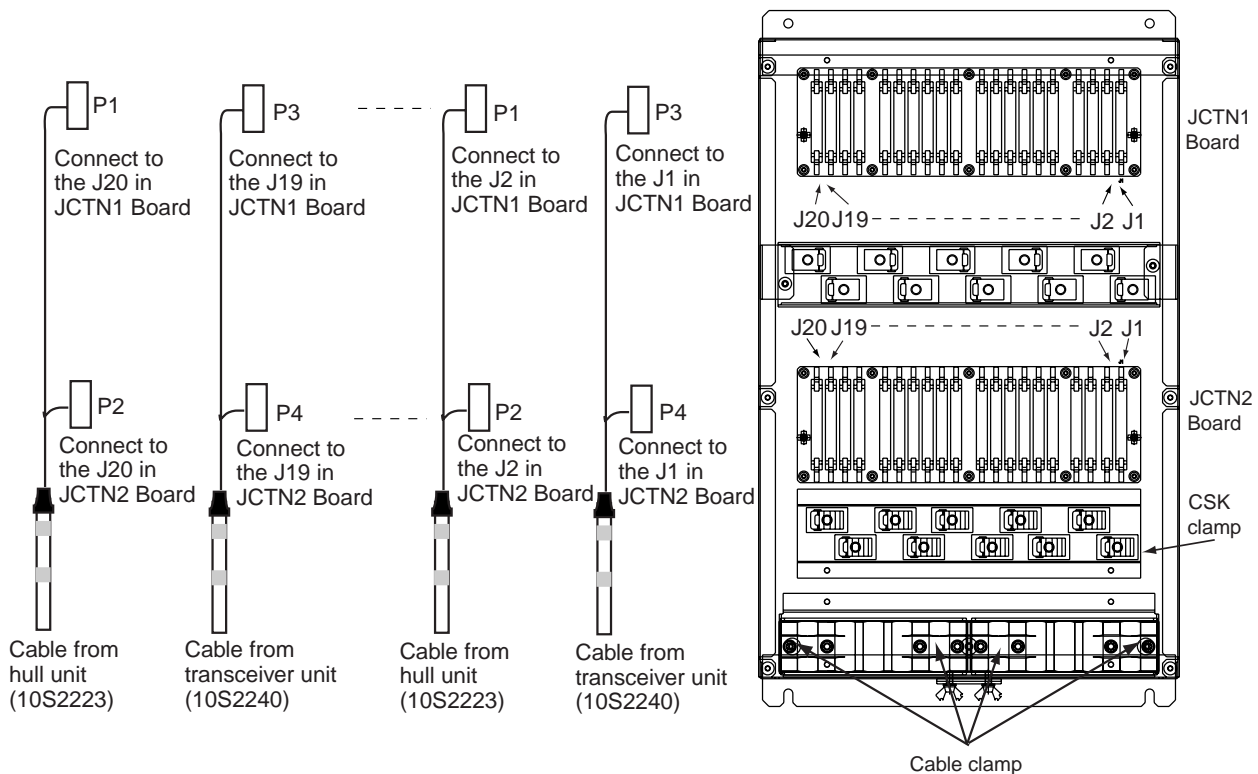

Junction box, cover removed

3. Lead in cable thru the appropriate location on the cable clamp and fix cable with appropriate CKS clamp. Connect each cable to circuit board as shown in the figure on the previous page.
Signal cable (10S2240) connects to "JUNCTION BOX" display side.
4. Lay the shield of each cable in the cable clamp.
5. Fasten the cable clamps.

2.5.2 Raise/Lower control box

Connect the power cable (3 ϕ) and the transceiver unit cable (10S2078) as shown below.

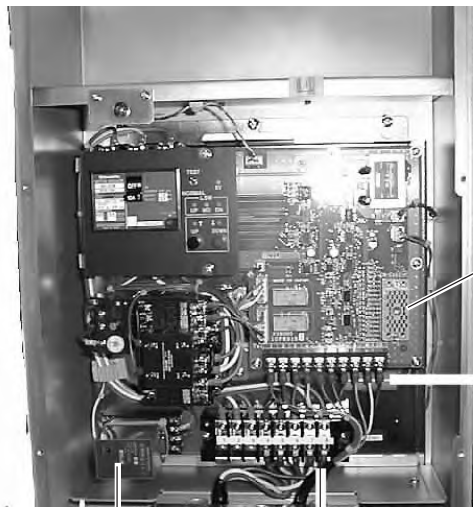

CN-C101
Connect the transceiver cable (10S2078) here.

TB-C101
Connect the power cable TPYCY-4 (Japan Industrial Standard) or the equivalent cable to this terminal board.

LED (Red)
For detection of phase reversal on 3 phase power cable

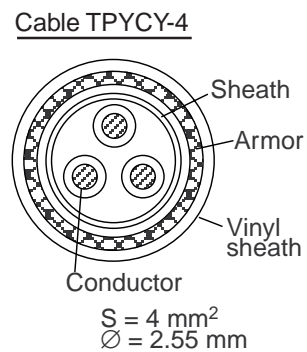

Confirm LED after completing the installation. The LED lights (in red) if power connection is correct. If it is off, turn off power from the mains switchboard, check the cable connection and recheck the LED. The hull unit does not work if this connection is wrong.

Normal phase: LED lights (in red).

Phase reversal: LED does not light.

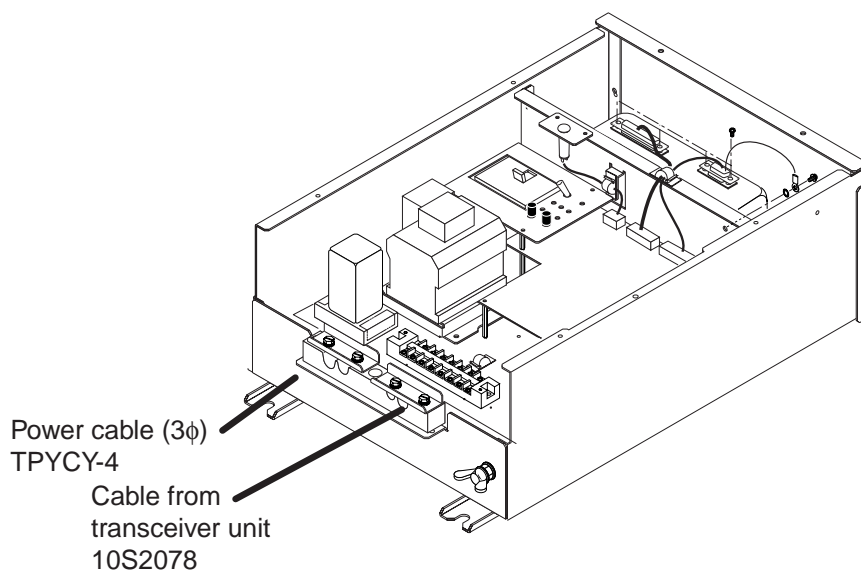

Raise/lower control box, cover removed

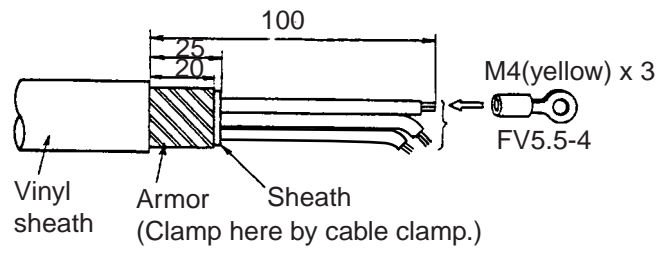

Power cable fabrication

2.6 Input Voltage and Fuses

The transceiver unit is shipped from the factory with its input voltage set for 230 VAC and a 10 A fuse inserted in F601 and F602. For other voltages, change toggle switch positions and fuses as below.

Input voltage

Set the toggle switches S603, S604 and S605 according to input voltage, referring to the table below.

Input (TB-B101)	S603	S604	S605	Default setting
100 V	L	L	L	/
110 V	H	L	L	
115 V	H	H	L	
220 V	H	L	H	
230 V	H	H	H	
				Default setting

Fuses

Change the fuse in F601 and F602 according to input voltage, referring to the table below.

Input (TB-B101)	Fuse		Default setting
	F601	F602	
100 V	20A	20A	/
110 V			
115 V			
220 V	10A	10A	Default setting
230 V			



WARNING

Use the proper fuse.

Use of a wrong fuse can result in damage to the equipment or cause fire.

Marking the label

After setting toggle switches and changing the fuses, mark the voltage which applies on the label on the inside of the cover. In the example shown right, 100 V is marked so 20A fuses must be used.

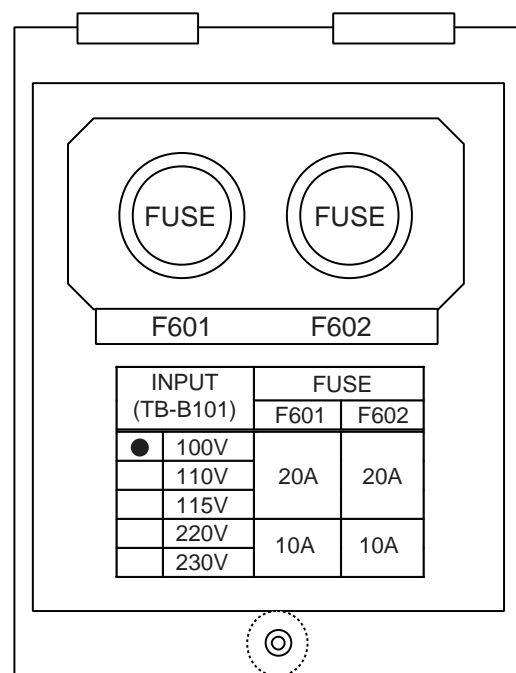

3. ADJUSTMENT AND CHECK

3.1 Hull Unit Check

Note: Before conducting this check (at the dry dock) transmission must be stopped. Default setting of TX power is OFF. Confirm that transmission is off as follows:

1. Turn on the power, and then press the [MENU] key to show the main menu.

MENU	QUIT
TX PULSE LENGTH-H :9	
TX POWER-H :9	
TVG-NEAR-H :0	
TVG-MEDIUM-H :0	
TVG-FAR-H :0	
AGC-H :0	
2ND AGC-H :0	
ECHO AVERAGE-H :0	
COLOR-H :COLOR 1	
COLOR RESPONSE-H :COLOR CURVE 3	
<hr/>	
H-SCAN SETTING...	
V-SCAN SETTING...	
OTHERS...	

Main menu

2. Use the trackball to choose OTHERS and press the [MENU] key.

MENU	QUIT
OTHERS	QUIT
<hr/>	
ES1 SETTING...	
ES2 SETTING...	
ERASE MARKS...	
DISPLAY SETTING...	
ALARM & AUDIO...	
PRESET, MEMORY CARD...	
INITIAL SETTING...	

OTHERS menu

3. Choose INITIAL SETTING and press the [MENU] key.

— CAUTION — THIS ITEM IS DEFINED AS NON- CHANGEABLE ITEM, ARE YOU SURE TO CHANGE IT TO CHANGEABLE ?	YES
	NO

4. Choose YES and press the [MENU] key.

MENU	QUIT
OTHERS	QUIT
INITIAL SETTING	QUIT
MARK DISPLAY... MARK SIZE... DATA DISPLAY... CURRENT VEC & WIND... NET SONDE SETTING... NET SHOOT SETTING... TARGET LOCK... STABILIZATION... TEST... INITIALIZATION...	

INITIAL SETTING menu

5. Choose TEST and press the [MENU] key.

MENU	QUIT
OTHERS	QUIT
INITIAL SETTING	QUIT
TEST	QUIT
BOARD TEST... PANEL TEST... TEST PATTERN... RX TEST... NOISE TEST... TX : OFF	

TEST menu

6. Choose TX and press the [MENU] key.

7. Choose OFF (if it is not already selected) and press the [MENU] key.

8. Choose QUIT at the top of the menu screen and press the [MENU] key.

How to check the hull unit

1. Press the POWER (I) switch on the control unit to turn on the equipment. Confirm that “ ON” lamp above the POWER switch and the ↓ switch light.

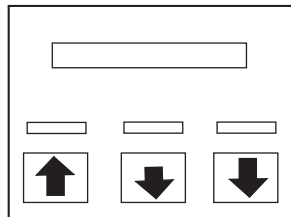

Transducer switches of the control unit

2. Confirm that the 5V and UP lamps on the raise/lower control box are lit.
3. Remove the cover of the raise/lower control box and use a multimeter to measure the following voltages:

Terminal	Terminal No.	Voltage
TB-C101	(1) – (2), (6) – (7)	220 VAC
	(2) – (3), (7) – (8)	220 VAC
	(1) – (3), (6) – (8)	220 VAC

4. In the raise/lower control box, set the TEST/NORMAL switch to TEST. Press the [DOWN] switch to confirm that the transducer lowers. Also, while the transducer is being lowered, check that the MD LED lights when the MD L. SW kicks. Note that the MD L. SW does not stop the transducer when the TEST/NORMAL switch is in the TEST position.

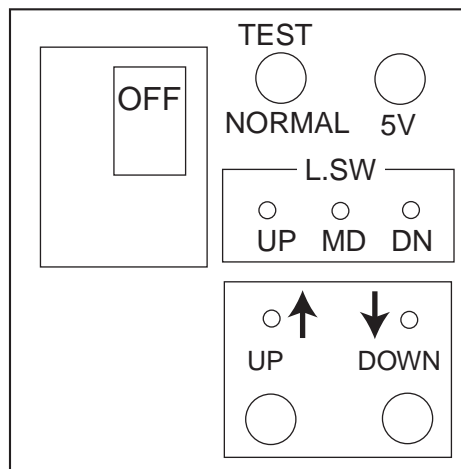

Control unit (in hull unit)

5. Press and release the [DOWN] switch. Confirm that the transducer stops at the moment the switch is released.
6. Press the [DOWN] switch again. Confirm that the transducer stops at the moment the lower limit switch kicks.
7. Confirm that the [UP] switch operates in a similar manner.

8. Check that LEDs on the panel of the raise/lower control box light as follows:
 - 1) UP, MD and DN LEDs light when corresponding limit switch is kicked.
 - 2) UP and DOWN LEDs light while UP and DOWN switches are pressed and extinguish when the switches are released.
 - 3) Set the TEST/NORMAL switch to NORMAL.
9. At the control unit, press the ↓ (mid position) switch. Confirm that the lamp above the switch blinks while the transducer is being lowered, a short beep sounds when the mid limit switch kicks, and the lamp lights when the transducer is lowered to the mid position.
10. Press the ↓ switch. Confirm that the lamp above the switch blinks while the transducer is being lowered, a short beep sounds when the mid limit switch is kicked, and the lamp lights when the transducer is fully lowered.
11. Press the ↑ switch. Confirm that the lamp above the switch blinks while the transducer is being raised, a short beep sounds when the mid limit switch is kicked, and the lamp lights when the transducer is fully raised.
12. Press the OFF switch. Confirm that the transducer is completely retracted and then the power is turned off.
13. With the transducer lowered (mid or fully lowered), confirm that the transducer is raised when ↑ or OFF is pressed.

3.2 Heading Adjustment

When the BOW mark on the flange of the hull unit cannot be directed toward ship's bow, adjust the heading so an echo which is dead ahead appears dead ahead on the display.

1. Referring to the previous section, set the TX (transmission) to ON.
2. Locate a target in the bow direction (buoy, for example) and display it on a near range. If the target appears at 12 o'clock the heading alignment is correct. If it does not, measure the error and go to step 2.

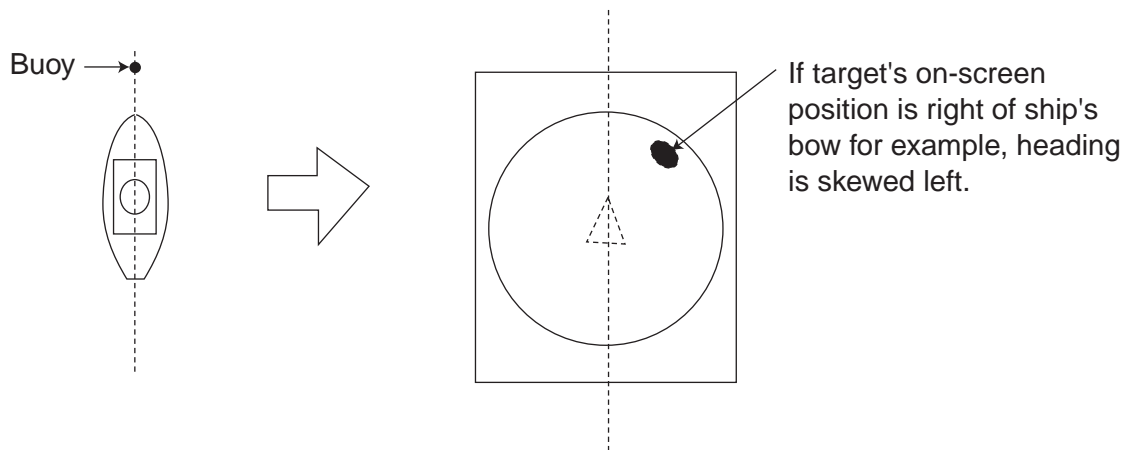

Heading adjustment

3. Turn off the power and then turn it on again while pressing and holding down the [MENU] key. Release the [MENU] key after the self-test screen appears. After the picture appears, press the [MENU] key three times to open the SYSTEM menu.

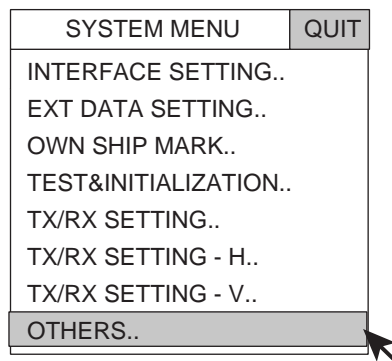

SYSTEM menu

4. Use the trackball to choose OTHERS and press the [MENU] key.
5. Choose HEADING ADJUST and press the [MENU] key.

MENU	QUIT
OTHERS	QUIT
LANGUAGE	: ENGLISH
HEADING ADJUST	: 0°
ES2 SELECT	: ES
ES DRAFT OFFSET	: 0.0 m
EVENT KEY	: EVENT
AUTO TILT	: WIDE
SELECT USER PROG	: H/V INTERLOCK
TRACKBALL SPEED	: NORMAL
HULL UNIT STROKE	: 1200mm

QUIT
CANCEL
▲
▼

OTHERS menu, HEADING ADJUST

6. Choose ▲ or ▼ to choose direction (plus or minus, respectively) in which to increment or decrement setting and then press the [MENU] key to set. Each pressing of the [MENU] key changes the setting in increments of 1°. The setting range is -180° to +179°.
7. Choose QUIT to finish the adjustment and press the [MENU] key.
8. Choose QUIT at the top of the menu screen and press the [MENU] key to close all menus.

3.3 Configuring Own Ship Mark

Set own ship's dimensions and the location of the transducer to accurately display the own ship mark on the display.

1. Press the [MENU] key to display the SYSTEM menu.

SYSTEM MENU	QUIT
INTERFACE SETTING..	
EXT DATA SETTING..	
OWN SHIP MARK..	
TEST&INITIALIZATION..	
TX/RX SETTING..	
TX/RX SETTING - H..	
TX/RX SETTING - V..	
OTHERS..	

System menu

2. Use the trackball to choose OWN SHIP MARK and press the [MENU] key.

MENU	QUIT
OWN SHIP MARK	QUIT
SHIP'S LENGTH : 75m	
SHIP'S WIDTH : 20m	
TD POSITION 1 : 15m	
TD POSITION 2 : 0.0m	

OWN SHIP MARK menu

3. Use the trackball to choose SHIP'S LENGTH.
4. Press the [MENU] key to show the setting window.

MENU	QUIT
OWN SHIP MARK	QUIT
SHIP'S LENGTH : 75m	
SHIP'S WIDTH : 20m	
TD POSITION 1 : 15m	
TD POSITION 2 : 0.0m	

QUIT
CANCEL
▲
▼

OWN SHIP MARK menu, setting window

5. Choose ▲ or ▼ and then operate the [MENU] key to set the ship's length (15 to 150 m).
6. Choose QUIT to finish the setting.
7. Set the SHIP'S WIDTH (5 to 30 m), TD POSITION 1 (5 to 50 m) or TD POSITION 2 (-10.0 to 10.0 m) similarly.

TD POSITION 1: Set the transducer's distance from the bow.

TD POSITION 2: Set the transducer's distance from the keel. Choose [+] for starboard, [-] for port.

8. Choose QUIT at the top of the menu screen and press the [MENU] key to close all menus.

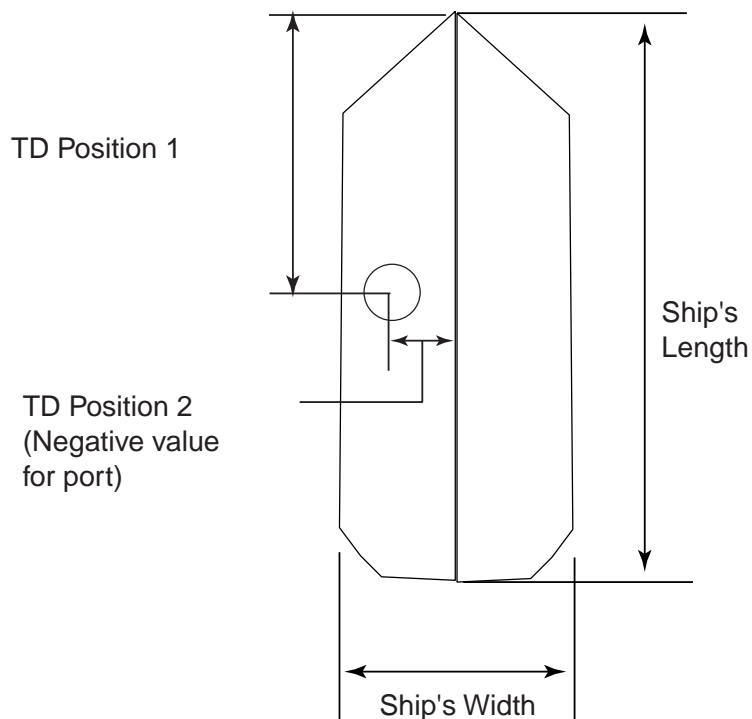

Ship shape description

3.4 Other SYSTEM Menu Items

This section mainly shows you how to set up according to external equipment connected. Default settings are underlined.

3.4.1 INTERFACE SETTING menu

MENU	QUIT
INTERFACE SETTING	QUIT
NMEA 1 BAUD RATE: 4800 bps	
NMEA 2 BAUD RATE: 4800 bps	
CIF BAUD RATE	: 4800 bps
AUX BAUD RATE	: 19200 bps
EXT KP INPUT	: DISABLE
EXT KP OUTPUT	: NEGATIVE

INTERFACE SETTING menu

NMEA 1 BAUD RATE

Set the transmission rate for the NMEA 1 port.
(4800 bps, 9600 bps, 19200 bps, 38400 bps)

NMEA 2 BAUD RATE

Set the transmission rate for the NMEA 2 port.
(4800 bps, 9600 bps, 19200 bps, 38400 bps)

CIF BAUD RATE

Set the transmission rate for the CIF port. If the CS-120A is connected, choose "2400 bps".
(2400 bps, 4800 bps, 9600 bps, 19200 bps)

AUX BAUD RATE

Set the transmission rate for the AUX port. (2400 bps, 4800 bps, 9600 bps, 19200 bps)

EXT KP INPUT

Set the input logic of KP from an external equipment. (DISABLE, POSITIVE, NEGATIVE)
DISABLE: No use external KP.

POSITIVE: Synchronize with leading edge of input pulse.

NEGATIVE: Synchronize with trailing edge of input pulse

Note: To transmit with external KP, set the TX INTERNAL to "0" in the H-SCAN SETTING menu.

EXT KP OUTPUT

Choose the KP output logic, POSITIVE or NEGATIVE. (POSITIVE, NEGATIVE)

3.4.2 EXT DATA SETTING menu

MENU	QUIT
EXT DATA SETTING	QUIT
DATE&TIME	: CIF
HEADING	: AD10S
LOG PULSE	: 200p/NM
SPEED&COURSE	: NMEA
SPEED SENSOR	: GPS/DR
LAT/LON	: NMEA
POSITIONING SENSOR	: AUTO SEL.
WATER DEPTH	: NMEA
WATER TEMP.	: NMEA
WATER CURRENT	: CIF
WIND	: CIF
NET DEPTH	: PULSE

EXT DATA SETTING menu

DATE & TIME

Choose the input format for data and time data. (NONE, CIF, NMEA)

HEADING

Choose the input format for heading data. (NONE, AD10S, CIF, NMEA)

LOG PULSE

Set the log pulse rate for the log signal. (200 p/NM, 400 p/NM)

SPEED & COURSE

Choose the input format for ship's speed and course data. When choosing the LOG&HEADING, the heading data is used instead of the course data. (NONE, LOG&HEADING, CIF, NMEA)

SPEED SENSOR

Choose the input format for speed and course data. This setting is ineffective when LOG&HEADING is selected as speed and course source. (NONE, GPS/DR, DOPPLER/DR)

LAT/LON

Choose the input format for ship's position data. (NONE, CIF, NMEA)

POSITIONING SENSOR

Choose the type of the navigator to use. For AUTO SEL., the priority is GPS/DR>LORAN-C. (LORAN-C, GPS/DR, AUTO SEL.)

WATER DEPTH

Choose the input format for depth data. (NONE, CIF, NMEA)

WATER TEMP.

Choose the input format for water temperature data. (NONE, CIF, NMEA)

WATER CURRENT

Choose the input format for water current data. (NONE, CIF, NMEA)

WIND

Choose the input format for wind data. (NONE, CIF, NMEA)

NET DEPTH

Choose the input format for net depth data. (NONE, CIF, PULSE)

Data sentences (NMEA 0183, FURUNO proprietary)

NMEA Input

Position (L/L)	GGA, GLL, GNS, RMA, RMC
Heading	HCC, HCD, HDG, HDM, HDT
Course	VTG
Speed	VBW, VHW
Current	CUR, VDR
Depth	DBS, DBT, DPT
Temperature	MTW
Wind	MWV
Date Time	ZDA
GPS gyro	Att (FURUNO proprietary data sentence)

NMEA Output

Position	TLL
----------	-----

FURUNO proprietary data sentences (all output)

Fish school speed	FKV
Relative bearing, range depth and speed of fish school	TFM
Relative bearing, range and depth of position tracking mark	TLM
Bearing, range and depth of event mark	EVT
Bearing, range, depth and volume of fish estimate mark	FMG
Bearing, range, depth and speed of fish school mark	FVC
Bearing and range of net shoot mark	SHT
Scattering strength (SV), area, volume and abundance of fish school	TLF
Scan setting parameter (1 to 6) at each Tx	SD3 - SD8

3.4.3 OTHERS menu

MENU	QUIT
OTHERS	QUIT
LANGUAGE	: English
HEADING ADJUST	: 0°
ES2 SELECT	: ES
ES DRAFT OFFSET	: 0.0 m
EVENT KEY	: EVENT
AUTO TILT	: WIDE
SELECT USER PROG	: H/V INTERLOCK
TRACKBALL SPEED	: NORMAL
HULL UNIT STROKE	: 1200mm

OTHERS menu

LANGUAGE

Choose the language to use. (JAPANESE, ENGLISH)

HEADING ADJUST

See “3.2 Heading Adjustment”.

ES2 SELECT

Choose the equipment connected to the ES2 port; echo sounder or net recorder. (ES, NET REC)

ES DRAFT OFFSET

When connecting an echosounder, you may enter the ship’s draft if you prefer to display depth from the draft rather than depth from the transducer. (0.0 m to 10.0 m, increments of 0.1 m)

EVENT KEY

Choose the key to use to enter own ship’s position, EVENT or SHOOT. When choosing SHOOT, the shoot function becomes inoperative. (EVENT, SHOOT)

AUTO TILT

Choose the range for the auto tilt form WIDE (± 2 to 10° , ± 4 to 16° , ± 6 to 20°) or NARROW (± 1 to 4° , ± 2 to 6° , ± 3 to 8°). (WIDE, NARROW)

SELECT USER PROG

Choose whether to program horizontal and vertical displays together or individually, by the USER PROG control. H/V INTERLOCK, the default setting, commonly applies control settings to the horizontal and vertical displays. H/V INDIVIDUAL enables individual adjustment of horizontal and vertical displays.

TRACKBALL SPEED

Choose the speed of trackball movement (inside menu window only).
(SLOW, NORMAL, FAST)

HULL UNIT STROKE

Choose the stroke length of the hull unit. (1200 mm, 1600 mm).

3.5 CONE Board Setting in the Processor Unit

Adjust the potentiometers on the CONE Board in the processor unit, referring to the table shown below.

Location No.	Name	Resistance value	Function	Adjustment
R118	ALARM	10 k Ω	Adjust the volume of audio alarm.	CW: Large CCW: Small
R119	ES2_OFF	1 k Ω	Adjust ES2 signal offset.	CW: Noise decrease CCW: Noise increase
R167	ES2_GAIN	10 k Ω	Adjust ES2 signal gain.	CW: Gain increase CCW: Gain decrease
R168	ES1_OFF	1 k Ω	Adjust ES1 signal offset.	CW: Noise decrease CCW: Noise increase
R209	ES1_GAIN	10 k Ω	Adjust ES1 signal gain.	CW: Gain increase CCW: Gain decrease

3.5.1 Adjustment of signal level (echo sounder connected)

Adjusts the output level of the echo sounder on the CONE Board as below.

1. Choose an echo sounder display (ES1 or ES2) from the menu.
2. For ES1, adjust R168 to suppress noise, and then adjust R209 so that the picture condition is similar to that of connected echo sounder connected to the FSV-30.
3. For ES 2, adjust R119 to suppress noise, and then adjust R167 so that the picture condition is similar to that of echo sounder connected to the FSV-30.

3.5.2 Adjusting the volume of the audio alarm

The volume of the audio alarm cannot be adjusted from the control unit. If necessary, adjust R118 on the CONE Board to choose appropriate volume.

3.6 DIP Switch Setting

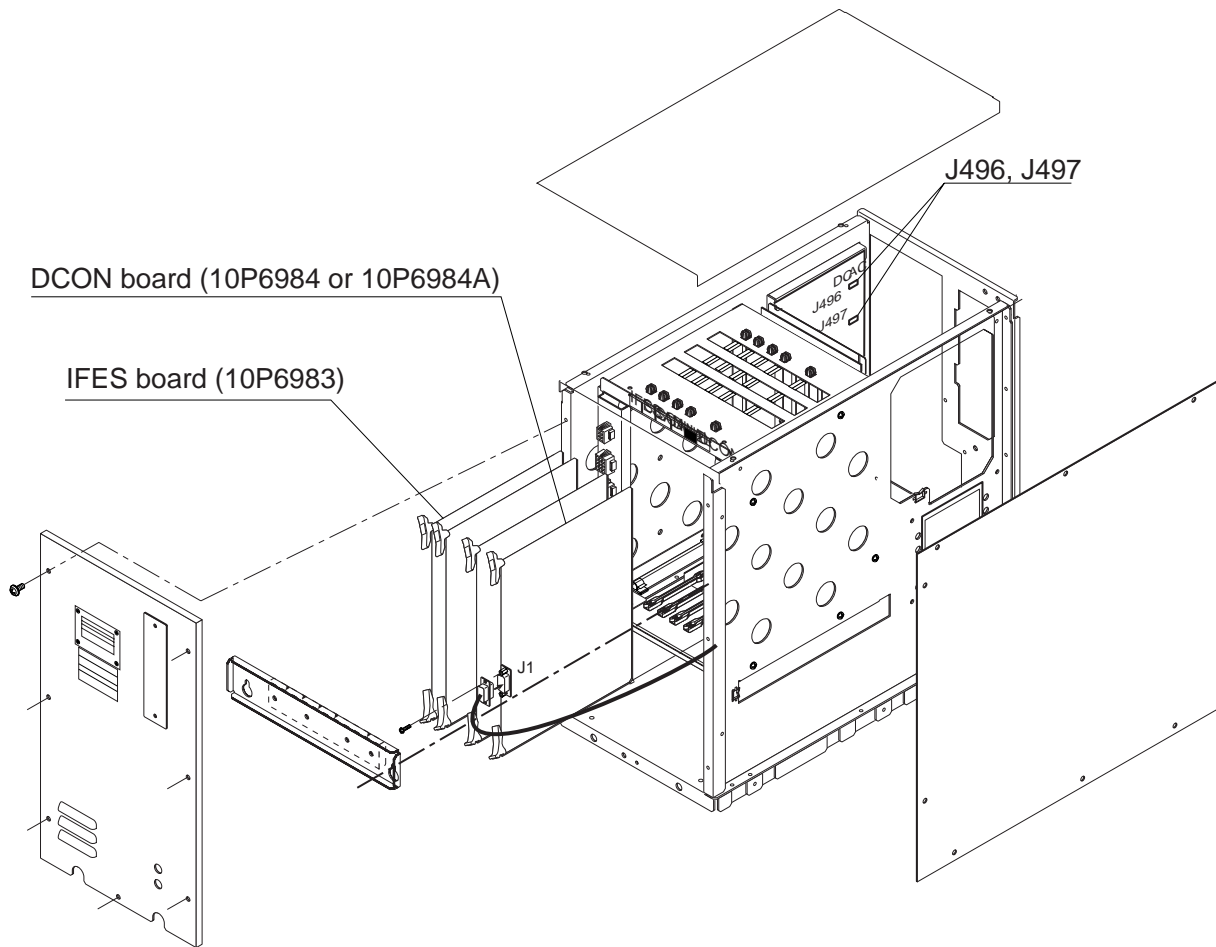

Processor unit, inside view

3.6.1 CIF2/NMEA2 connector interface selection

The signal format for the CIF2/NMEA2 port (at the back of the processor unit) can be set for CIF or NMEA by DIP switch S2-8 on the IFES Board (10P6983). The default format is OFF (CIF).

DIP switch setting	Format
S2-#8: ON	NMEA
S2-#8: OFF	CIF

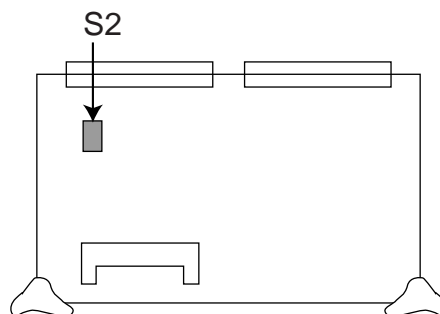

IFES Board (10P6983)

3.6.2 Choosing echosounder signal

There are two kinds of echosounder signals, AC signal and DC signal. Set the appropriate jumper on the CONE board as below according to the input port. The default setting is AC. See page 3-14 for parts location.

Input port	Jumper
ES1	J497
ES2/NET	J496

Note: The SIGOUT (AC signal) terminal and REC terminal (DC signal) in the output port are provided for a FURUNO echosounder. Therefore, when using the SIGOUT terminal, it is not necessary to change the above-mentioned jumper setting.

(This page intentionally left blank.)

4. CONNECTING THE EXTERNAL INTERFACE CS-120A

When upgrading from the CSH-20 series sonar, the External Interface CS-120A can be used. Connect the CS-120A to the processor unit as shown on the next page. However, we recommend that you connect external devices directly to the processor unit, to avoid signal delay.

Install the following power supply kit (option) in the processor unit to enable use of the CS-120A.

Name: Power Supply Kit Type: FSV-2403 Code No.: 000-067-013

Name	Type	Code No.	Qty	Remarks
Power supply pcb	LEA50F-24-XFND	000-143-913	1	
Spacer	SQ-22	000-159-305-10	4	
Protection sheet	10-071-3508	100-290-712	1	
Screw	M3x8 C2700W	000-163-190-10	4	
Connector (NJC)	NJC-203-PM	000-160-184-10	1	

1. Unfasten seven screws to remove the front cover of the processor unit.

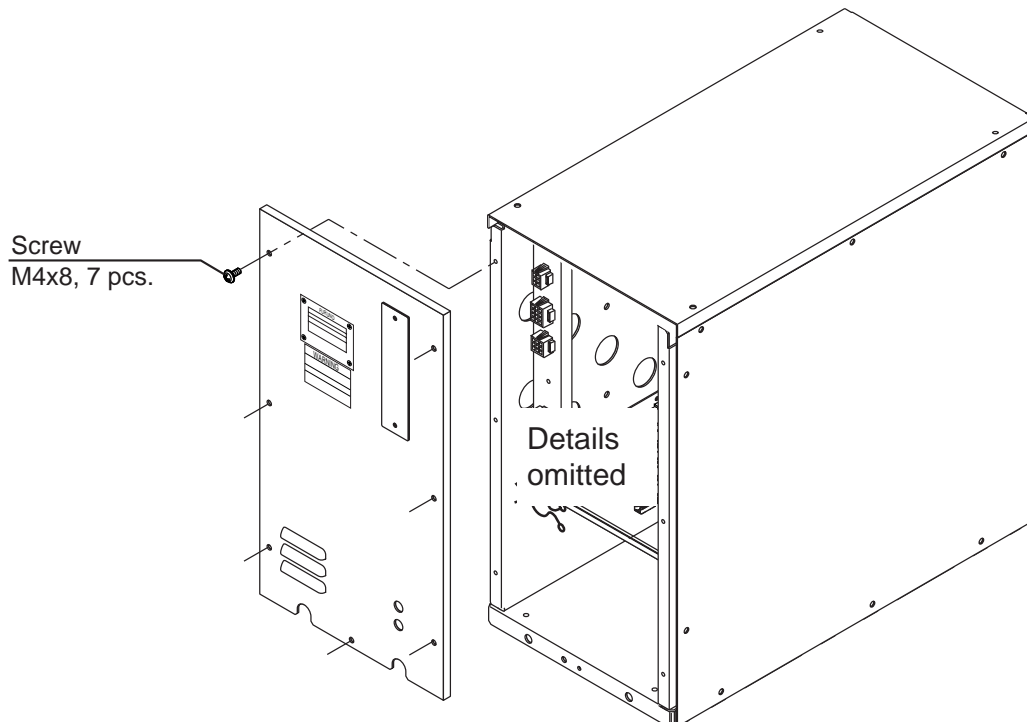

Processor unit, front view

- Remove two upset screws, detach the plugs J503, J502, J501, J504, J506 and J507, and then pull out the power module.

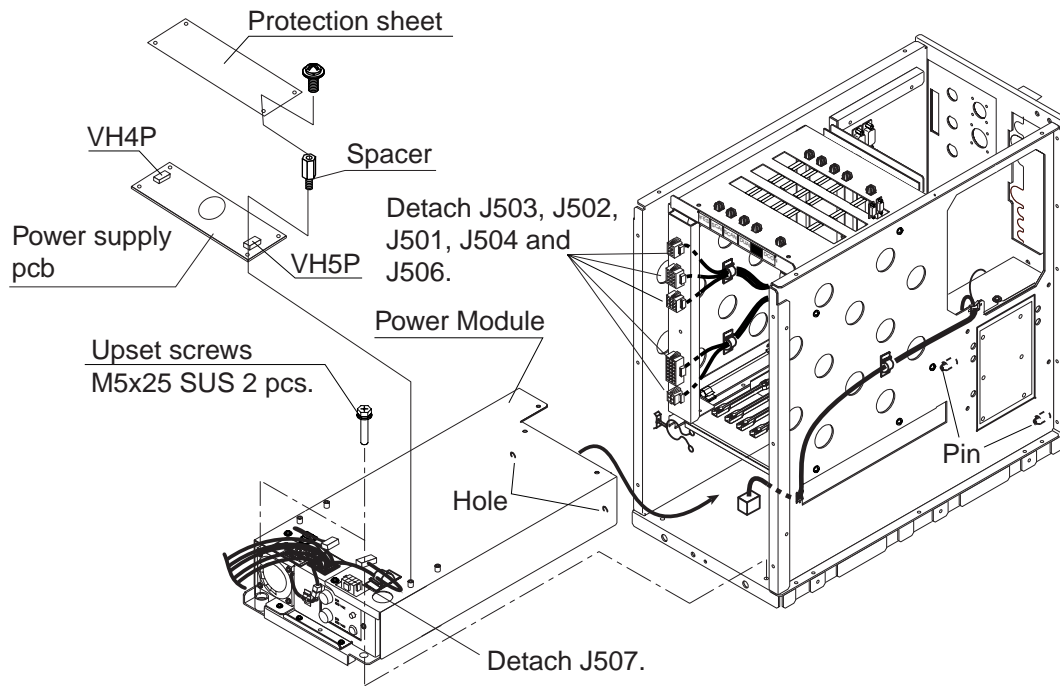

Processor unit, front view

- Fix the power supply pcb (supplied) to the power module with spacers (supplied).
- Connect two VH connectors (provided on the power module) to the power supply pcb.
- Set the protection sheet (supplied) to the power supply pcb and fasten it with four screws.
- Reattach the power module.
- Connect between the processor unit and CS-120A as follows.

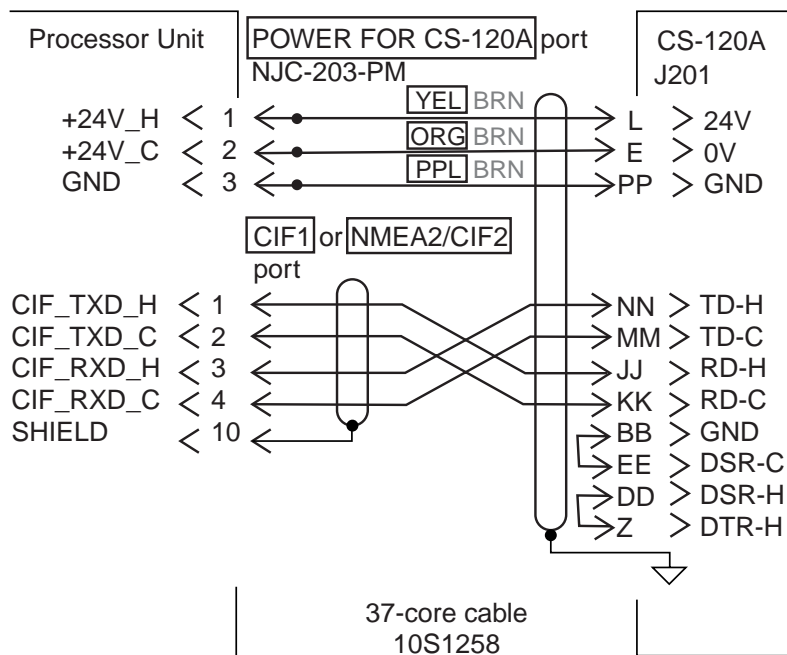

Wiring between processor unit and CS-120A

Note: An echosounder should be connected to the processor unit directly.

8. Set the DIP switch on the DCON Board as follows.

Input port	DIP switch setting on DCON Board
CIF1	S3-#2: ON
NMEA 2/CIF 2	S3-#3: ON

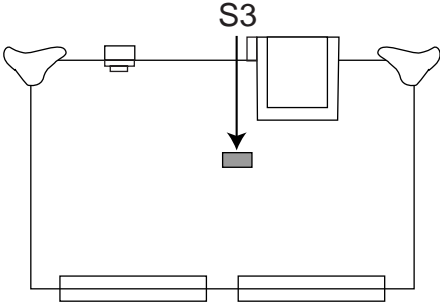

DCON Board (10P6984 or 10P6984A)

Note: If the CIF1 format is selected, change baud rate to 2400 bps. See CIF BAUD RATE on page 3-9 for details.

(This page intentionally left blank.)

PACKING LIST

10CT-X-9851 -2 1/1 A-1

FSV-3002-60-J/E, FSV-3002-70-J/E, FSV-3002S-60-E/70-E

NAME	OUTLINE	DESCRIPTION/CODE No.	Q'TY
ユニット			
制御部 PROCESSOR UNIT		FSV-3002-60	1
予備品			
SPARE PARTS			
予備品 SPARE PARTS		SP10-02601	1
		006-921-340	
付属品			
ACCESSORIES			
付属品 ACCESSORIES		FP10-02901	1
		007-008-780	
工事材料			
INSTALLATION MATERIALS			
工事材料 INSTALLATION MATERIALS		CP10-04506	1
		006-921-290	
工事材料 INSTALLATION MATERIALS		CP10-04502	1
		006-921-240	
図書			
DOCUMENT			
電源設定書 INPUT VOLTAGE SETTING		C12-00302-*	1
		000-149-243	
取扱説明書(英) OPERATOR'S MANUAL		OME-13231-*	1
		000-148-731	(*1)
装備要領書(和) INSTALLATION MANUAL		IMJ-13230-*	1
		000-148-573 **	
取扱説明書(和) OPERATOR'S MANUAL		OMJ-13230-*	1
		000-148-571 **	

1.コード番号末尾の[*][**]は、選用品の代表型式/コードを表します。
 CODE NUMBER ENDED BY "[]" INDICATES THE NUMBER OF TYPICAL MATERIAL.
 2. [*]の取扱説明書(英)は、FSV-30S専用です。
 *1 FOR FSV-30S.

(略図の寸法は、参考値です。 DIMENSIONS IN DRAWING FOR REFERENCE ONLY.)
 10CT-X-9851

FURUNO

A-2

工事材料表

番号 NO.	名称 NAME	略図 OUTLINE	型名/規格 DESCRIPTIONS		数量 Q'TY	用途/備考 REMARKS
			CODE NO.	CODE NO.		
1	コネクタ (8016) CONNECTOR (8016)		008016-038-313/61HFV CODE NO.	000-159-017-10	1	制御部用 FOR PROCESSOR UNIT
2	コネクタピン (8017) CONTACT PIN (8017)		60-8017-0313-00339F+ 60-8017-0313-00-339 CODE NO.	000-159-417-10 000-519-542-00	2	制御部用 FOR PROCESSOR UNIT
3	六角スリッパ ねじ HEX BOLT (SLOTTED WASHER HEAD)		M6X25 SUS304 M6X25 SUS304 CODE NO.	000-102-949-10 000-802-771-00	6	制御部用 FOR PROCESSOR UNIT
4	コネクタ (NCS) CONNECTOR (NCS)		NCS-253-P NCS-253-P CODE NO.	*R0HS* 000-160-153-10 000-506-503-10	1	制御部用 FOR PROCESSOR UNIT

型式/コード番号が2段の場合、下段より上段に代わる選用品であり、どちらが入っています。なお、品質は変わりません。
 TWO TYPES AND CODES MAY BE LISTED FOR AN ITEM. THE LOWER PRODUCT MAY BE SHIPPED IN PLACE OF THE UPPER PRODUCT.
 QUALITY IS THE SAME.
 (略図の寸法は、参考値です。 DIMENSIONS IN DRAWING FOR REFERENCE ONLY.)

FURUNO ELECTRIC CO., LTD

1000-X-9402

FURUNO

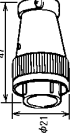
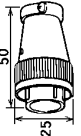

工事材料表

CODE NO.		TYPE		1000-X-9406 -3		1/1	
INSTALLATION MATERIALS		NAME		OUTLINE		REMARKS	
番号 NO.	名称	略図	型名/規格 DESCRIPTIONS	数量 Q'TY	用途/備考	REMARKS	
1	コネクタ (SRGN) CONNECTOR (SRGN)		SRONGAI 3-5P CODE NO. 000-160-728-10	1			
2	コネクタ (SRGN) CONNECTOR (SRGN)		SRONGAI 6-10P CODE NO. 000-160-728-10	1			

型式/コード番号が2段の場合、下段より上段に代わる標準部品であり、どちらが入っています。なお、品質は変わりません。
 TWO TYPES AND CODES MAY BE LISTED FOR AN ITEM. THE LOWER PRODUCT MAY BE SHIPPED IN PLACE OF THE UPPER PRODUCT. QUALITY IS THE SAME.
 (略図の寸法は、参考値です。 DIMENSIONS IN DRAWING FOR REFERENCE ONLY.)

PACKING LIST

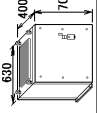
FSV-301

NAME UNIT		OUTLINE		DESCRIPTION/CODE No.		Q'TY	
ユニット							
送受信装置				FSV-301		1	
予備品		SPARE PARTS					
予備品				SPT0-03101		1	
SPARE PARTS				007-008-530			
工事材料							
工事材料		INSTALLATION MATERIALS					
INSTALLATION MATERIALS				CPT0-06201		1	
				007-008-540			

(略図の寸法は、参考値です。 DIMENSIONS IN DRAWING FOR REFERENCE ONLY.)
 10CT-X-9852

PACKING LIST

FSV-303

NAME		OUTLINE		DESCRIPTION/CODE No.	QTY
ユニット					
上下装置				FSV-303	1
HULL UNIT				000-067-068-00	
予備品					
予備品				SP10-02603	1
SPARE PARTS				006-921-360-00	
現地組部品					
現地組部品説明					
LOCAL ASSEMBLING				C12-00202-*	1
				000-146-864-1*	
0リング (V)				00 0318A (V585)	1
O-RING				000-166-370-10	
7-木板				WEA-1004-0 ROHS	1
COPPER STRAP				500-310-040-10	
六角ボルト 全社'				M20X120 SUS304	14
HEXAGONAL HEAD SCREW				000-162-825-10	
六角ナット				M20 SUS304	38
HEX. NUT				000-167-476-10	
ミカ丸平座金				M20 SUS304	33
FLAT WASHER				000-167-452-10	
ハネ座金				M20 SUS304	19
SPRING WASHER				000-167-401-10	
圧着端子				FV5. 5-4 (LF)	3
CRIMP-ON LUG				000-166-744-10	

型式/コード番号が2段の場合、下段より上段に代わる過渡期品であり、どちらかが入っています。なお、品質は変わりません。
TWO TYPES AND CODES MAY BE LISTED FOR AN ITEM. THE LOWER PRODUCT MAY BE SHIPPED IN PLACE OF THE UPPER PRODUCT. QUALITY IS THE SAME.
(略図の寸法は、参考値です。DIMENSIONS IN DRAWING FOR REFERENCE ONLY.)

FURUNO

工事材料表







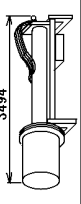

INSTALLATION MATERIALS

番号 NO.	名称 NAME	略図 OUTLINE	型名/規格 DESCRIPTIONS		数量 QTY	用途/備考 REMARKS
			CODE NO.	DESCRIPTIONS		
1	コネクタ (8016) CONNECTOR (8016)		008016-038-31376 HVF		1	送受信装置用 FOR TRANSCIEIVER UNIT
2	コネクタピン (8017) CONTACT PIN (8017)		60-8017-0313-00339F+		2	送受信装置用 FOR TRANSCIEIVER UNIT
3	圧着端子 CRIMP-ON LUG		FV2-4 FV2-4 7#		3	送受信装置用 FOR TRANSCIEIVER UNIT
4	7-木板 COPPER STRAP		WEA-1004-0 ROHS WEA-1004-0		1	送受信装置用 FOR TRANSCIEIVER UNIT

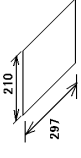
型式/コード番号が2段の場合、下段より上段に代わる過渡期品であり、どちらかが入っています。なお、品質は変わりません。
TWO TYPES AND CODES MAY BE LISTED FOR AN ITEM. THE LOWER PRODUCT MAY BE SHIPPED IN PLACE OF THE UPPER PRODUCT. QUALITY IS THE SAME.
(略図の寸法は、参考値です。DIMENSIONS IN DRAWING FOR REFERENCE ONLY.)

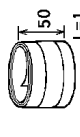
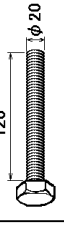
PACKING LIST
FSV-304



100T-X-9854 -3 1/1
A-7

NAME	OUTLINE	DESCRIPTION/CODE No.	QTY
ユニット			
上下装置 HULL UNIT		FSV-304 000-067-069-00	1
予備品			
予備品 SPARE PARTS		SP10-02603 006-921-360-00	1
現地組部品			
現地組部品説明 LOCAL ASSEMBLING PARTS			
LOCAL ASSEMBLING		C12-00202-* 000-146-864-1*	1
0リング (V)		CO 0318A (V585)	1
0-RING		000-166-370-10	1
銅板 COPPER STRAP		WEA-1004-0 ROHS 500-310-040-10	1
六角ボルト 全社 HEXAGONAL HEAD SCREW		M20X120 SUS304 000-162-825-10	14
六角ナット HEX. NUT		M20 SUS304 000-167-476-10	38
平丸 FLAT WASHER		M20 SUS304 000-167-452-10	33
バネ SPRING WASHER		M20 SUS304 000-167-401-10	19
圧着端子 CRIMP-ON LUG		FV5. 5-4 (LF) 000-166-744-10	3

型式コード番号が2段の場合、下段より上段に代わる過渡期品であり、どちらが入っています。なお、品質は変わりません。
TWO TYPES AND CODES MAY BE LISTED FOR AN ITEM. THE LOWER PRODUCT MAY BE SHIPPED IN PLACE OF THE UPPER PRODUCT. QUALITY IS THE SAME.
(略図の寸法は、参考値です。 DIMENSIONS IN DRAWING FOR REFERENCE ONLY.) 100T-X-9854

PACKING LIST
FSV-2401-* / FSV-3001-* / FSV-8401-*

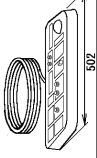
1000-X-9852 -2 1/1
A-8

NAME	OUTLINE	DESCRIPTION/CODE No.	QTY
ユニット			
操作部 CONTROL UNIT		FSV-2401-* / 3001-* / 8401-* 000-067-003-00	1 ** (*1)
付属品			
付属品 ACCESSORIES		FP10-02201 006-922-390-00	1

1.コード末尾に[*][**]の付いたユニットは代表の型式/コードを表示しています。
DOUBLE ASTERISK DENOTES COMMONLY USED EQUIPMENT.
2.(*1)印のケーブル組品は、5m、10mの長さがあります。
5m、10m CABLE IS SELECTIVE ON DEMAND.

型式コード番号が2段の場合、下段より上段に代わる過渡期品であり、どちらが入っています。なお、品質は変わりません。
TWO TYPES AND CODES MAY BE LISTED FOR AN ITEM. THE LOWER PRODUCT MAY BE SHIPPED IN PLACE OF THE UPPER PRODUCT. QUALITY IS THE SAME.
(略図の寸法は、参考値です。 DIMENSIONS IN DRAWING FOR REFERENCE ONLY.) 1000-X-9852

FURUNO

付属品表

ACCESSORIES

CODE NO.		1000-X-9501-6		1/1	
TYPE		FP10-02201			
番号 NO.	名称 NAME	略図 OUTLINE	型名/規格 DESCRIPTIONS	数量 QTY	用途/備考 REMARKS
1	KB直付け金具 KB FIXING PLATE		03-144-1691-1 ROHS CODE NO. 100-265-941-10	1	操作部用 FOR CONTROL UNIT
2	ダストカバー KB DUST COVER KB		03-144-1693-0 ROHS CODE NO. 100-271-760-10 100-271-760-00	1	操作部用 FOR CONTROL UNIT
3	ダミーフィルム DUMMY FILM		05-040-0105-0 ROHS CODE NO. 100-117-120-10	1	操作部用 FOR CONTROL UNIT
4	フラット平座金 FLAT WASHER		M4 C2680R CODE NO. 100-168-235-10	2	操作部用 FOR CONTROL UNIT
5	六角ナット HEX. NUT		M4 C3604B CODE NO. 100-168-237-10	2	操作部用 FOR CONTROL UNIT
6	バネ座金 SPRING WASHER		M4 C5191W CODE NO. 100-168-238-10	2	操作部用 FOR CONTROL UNIT
7	オвалヘッドネジ OVAL HEAD SCREW		MAX12 C2700W MBN12 CODE NO. 100-163-309-10	2	操作部用 FOR CONTROL UNIT
8	六角ボルト (ワッシャーヘッド) HEX. BOLT (WASHER HEAD)		M6X10 SUS304 CODE NO. 100-163-757-10	2	操作部用 FOR CONTROL UNIT
9	ゴムの足 RUBBER FEET		SJ-5003 7/8 CODE NO. 100-165-669-10	4	操作部用 FOR CONTROL UNIT

型式/コード番号が2段の場合、下段より上段に代わる過渡部品であり、どちらかが入っています。なお、品質は変わりません。
TWO TYPES AND CODES MAY BE LISTED FOR AN ITEM. THE LOWER PRODUCT MAY BE SHIPPED IN PLACE OF THE UPPER PRODUCT.
QUALITY IS THE SAME.
(略図の寸法は、参考値です。 DIMENSIONS IN DRAWING FOR REFERENCE ONLY.)

FURUNO

付属品表

ACCESSORIES

CODE NO.		10CT-X-9501-0		1/1	
TYPE		FP10-02901			
番号 NO.	名称 NAME	略図 OUTLINE	型名/規格 DESCRIPTIONS	数量 QTY	用途/備考 REMARKS
1	メモリーカード MEMORY CARD		FP10-02902 CODE NO. 007-008-790	1	制御部用 FOR PROCESSOR UNIT

(略図の寸法は、参考値です。 DIMENSIONS IN DRAWING FOR REFERENCE ONLY.)

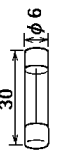
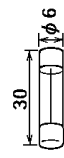
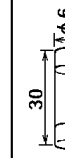
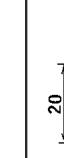
SHIP NO.		SPARE PARTS LIST FOR		U S E		SETS PER VESSEL	
				CODE NO. TYPE	007-008-530-00 SPT10-03101	100T-X-9301-3 BOX NO. P	1/1
ITEM NO.	NAME OF PART	OUTLINE	DWG. NO. OR TYPE NO.	QUANTITY WORKING PER SET	SPARE	REMARKS/CODE NO.	
1	Et-X GLASS TUBE FUSE		FG80, 250V 10A PBF	5		送受電装置用 FOR TRANSCEIVER UNIT 000-155-839-10	
2	Et-X GLASS TUBE FUSE		FG80, 250V 15A PBF	5		送受電装置用 FOR TRANSCEIVER UNIT 000-157-874-10	
3	Et-X GLASS TUBE FUSE		FG80, 250V 20A	5		送受電装置用 FOR TRANSCEIVER UNIT 000-155-786-10	
4	Et-X GLASS TUBE FUSE		FG80, 250V 5A PBF	5		送受電装置用 FOR TRANSCEIVER UNIT 000-157-570-10	
MFR'S NAME	FURUNO ELECTRIC CO., LTD.	DWG NO.	100T-X-9301	1/1			

(略図の寸法は、参考値です。 DIMENSIONS IN DRAWING FOR REFERENCE ONLY.)
 型式(「Et」)番号が2段の場合、下段より上段に代わる過渡期品であり、どちらかが入っています。 なお、品質は変わりません。
 TWO TYPES AND CODES MAY BE LISTED FOR AN ITEM. THE LOWER PRODUCT MAY BE SHIPPED IN PLACE OF THE UPPER PRODUCT. QUALITY IS THE SAME.

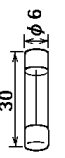
SHIP NO.		SPARE PARTS LIST FOR		U S E		SETS PER VESSEL	
				CODE NO. TYPE	006-921-340 SPT10-02601	1000-X-9301-1 BOX NO. P	1/1
ITEM NO.	NAME OF PART	OUTLINE	DWG. NO. OR TYPE NO.	QUANTITY WORKING PER SET	SPARE	REMARKS/CODE NO.	
1	Et-X FUSE		FG80, 250V 10A PBF FG80, 10A AC250V	2	2	指示装置>船荷卸用 FOR DISPLAY UNIT 000-155-839-10 000-549-067-00	
MFR'S NAME	FURUNO ELECTRIC CO., LTD.	DWG NO.	1000-X-9301	1/1			

(略図の寸法は、参考値です。 DIMENSIONS IN DRAWING FOR REFERENCE ONLY.)
 型式(「Et」)番号が2段の場合、下段より上段に代わる過渡期品であり、どちらかが入っています。 なお、品質は変わりません。
 TWO TYPES AND CODES MAY BE LISTED FOR AN ITEM. THE LOWER PRODUCT MAY BE SHIPPED IN PLACE OF THE UPPER PRODUCT. QUALITY IS THE SAME.

CODE NO.	006-921-360	1000-X-9303-1	1/1
TYPE	SPT0-02603	BOX NO. P	

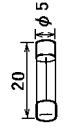
SHIP NO.		S P A R T S L I S T F O R				U S E		REMARKS/CODE NO.	
ITEM NO.	NAME OF PART	OUTLINE	DWG. NO. OR TYPE NO.	QUANTITY WORKING PER SET	QUANTITY SPARE PER VESSEL	SETS PER VESSEL	REMARKS		
1	1a-X FUSE		FGMB 250V 2A PBF FGMB 2A 250V	1	1	1/1	上下装置(制御器用) FOR HALL UNIT 000-157-497-10 000-122-000-00		

MFR'S NAME | FURUNO ELECTRIC CO., LTD. | DWG. NO. | 1000-X-9303 | 1/1

(略図の寸法は、参考値です。 DIMENSIONS IN DRAWING FOR REFERENCE ONLY.)
型式/コード番号が2段の場合、下段より上段に代わる過速部品であり、どちらが入っています。 なお、品質は変わりません。
TWO TYPES AND CODES MAY BE LISTED FOR AN ITEM. THE LOWER PRODUCT MAY BE SHIPPED IN PLACE OF THE UPPER PRODUCT. QUALITY IS THE SAME.

工事材料表

INSTALLATION MATERIALS

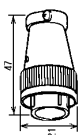
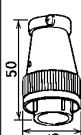
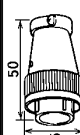
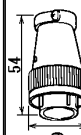
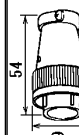
番号 NO.	名称 NAME	略 図 OUTLINE	型名/規格 DESCRIPTIONS	数量 Q'TY	用途/備考 REMARKS	
					CODE NO.	1/1
1	1a-X (SRCN) CONNECTOR (SRCN)		SRCN6A13-3P CODE NO. 000-160-722-10	1		
2	1a-X (SRCN) CONNECTOR (SRCN)		SRCN6A16-10P CODE NO. 000-160-728-10	1		
3	1a-X (SRCN) CONNECTOR (SRCN)		SRCN6A16-7P CODE NO. 000-160-730-10	1		
4	1a-X (SRCN) CONNECTOR (SRCN)		SRCN6A21-10P CODE NO. 000-160-735-10	1		
5	1a-X (SRCN) CONNECTOR (SRCN)		SRCN6A21-10S CODE NO. 000-160-736-10	1		

型式/コード番号が2段の場合、下段より上段に代わる過速部品であり、どちらが入っています。 なお、品質は変わりません。
TWO TYPES AND CODES MAY BE LISTED FOR AN ITEM. THE LOWER PRODUCT MAY BE SHIPPED IN PLACE OF THE UPPER PRODUCT. QUALITY IS THE SAME.
(略図の寸法は、参考値です。 DIMENSIONS IN DRAWING FOR REFERENCE ONLY.)
FURUNO ELECTRIC CO., LTD. | 1000-X-9410

490

450±1

FIXING HOLES
2-φ6.5 (取付穴)

表 1 TABLE 1

寸法区分 (mm) DIMENSIONS	公差 (mm) TOLERANCE
L ≤ 50	±1.5
50 < L ≤ 100	±2.5
100 < L ≤ 500	±3
500 < L ≤ 1000	±4

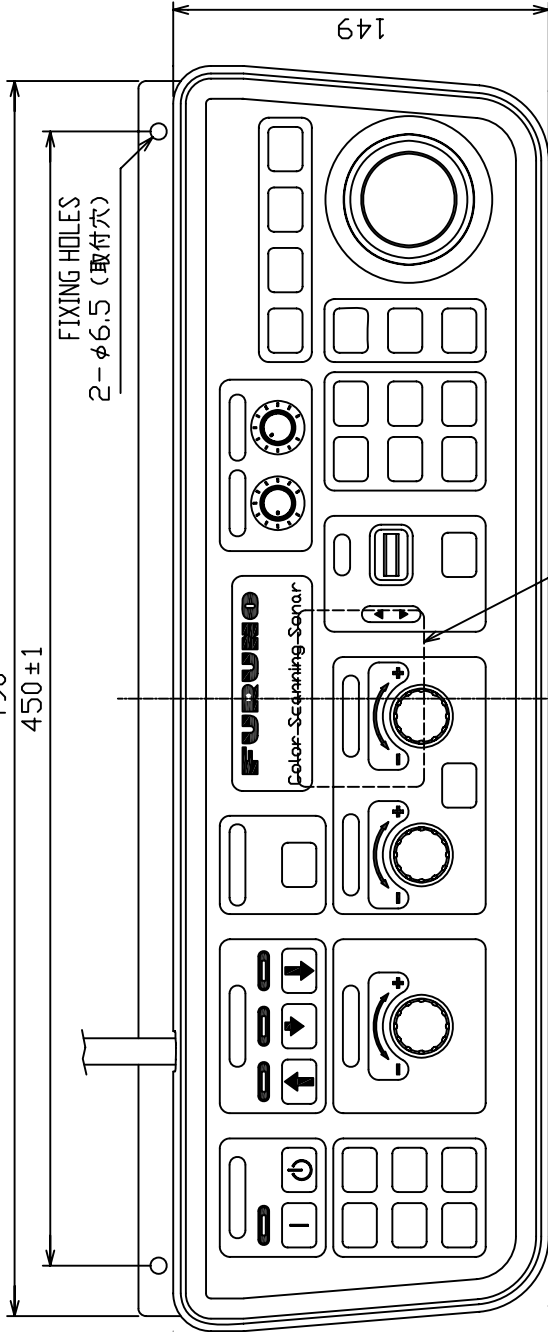

矢視 A
VIEW A

ユニット銘板
NAMEPLATE BOTTOM

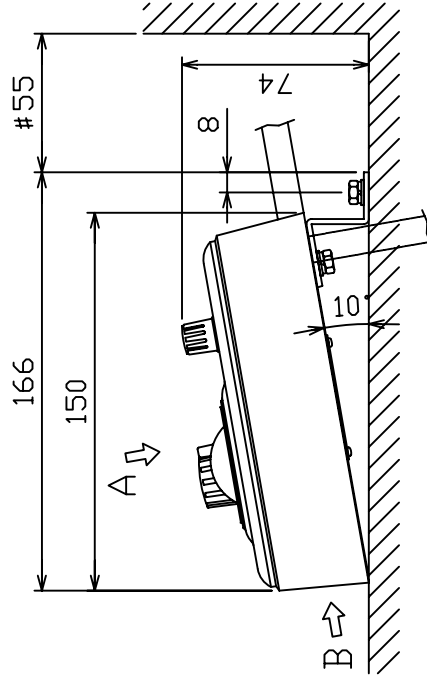
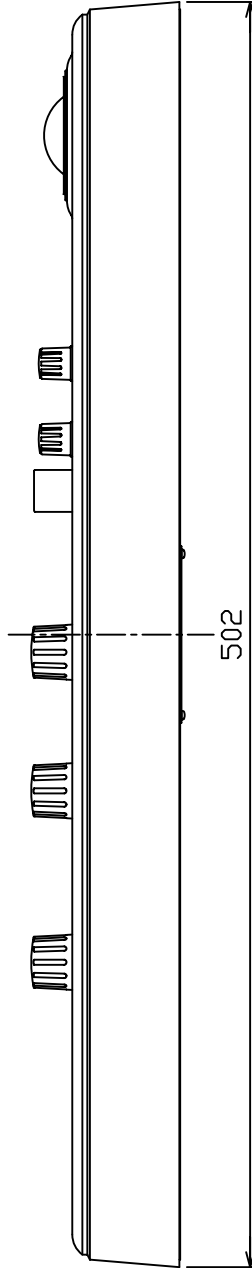

矢視 B
VIEW B

- 注記 1) #印寸法は最小サービス空間寸法とする。
 2) 指定外の寸法公差は表1による。
 3) 質量はKB直付け金具、及びケーブル(5m)を含む。
 4) 取付用ネジはトラスタップピンネジ呼び径5、またはM5ボルトを使用のこと。

- NOTE 1. # MINIMUM SERVICE CLEARANCE.
 2. TABLE 1 INDICATES TOLERANCE OF DIMENSIONS WHICH IS NOT SPECIFIED.
 3. MASS INCLUDES KB FIXING PLATE AND CABLE (5M).
 4. USE M5 BOLTS OR TAPPING SCREWS φ5 FOR FIXING THE UNIT.

DRAWN	Aug. 21/06	Maki	TITLE	FSV-240/300/8401
CHECKED		TAKAHASHI, T	名称	操作部 (KB直付け金具あり)
APPROVED		Y. Hatai	FSV-240/300	外寸図
SCALE	1/3	質量はケーブル重さを含む。 MASS W/ CABLE.	NAME	CONTROL UNIT (w/KB FIXING PLATE)
DWG No.	C1318-603-E	10-079-200G-0		OUTLINE DRAWING

表 1 TABLE 1

寸法区分 (mm) DIMENSIONS	公差 (mm) TOLERANCE
L ≤ 50	± 1.5
50 < L ≤ 100	± 2.5
100 < L ≤ 500	± 3
500 < L ≤ 1000	± 4

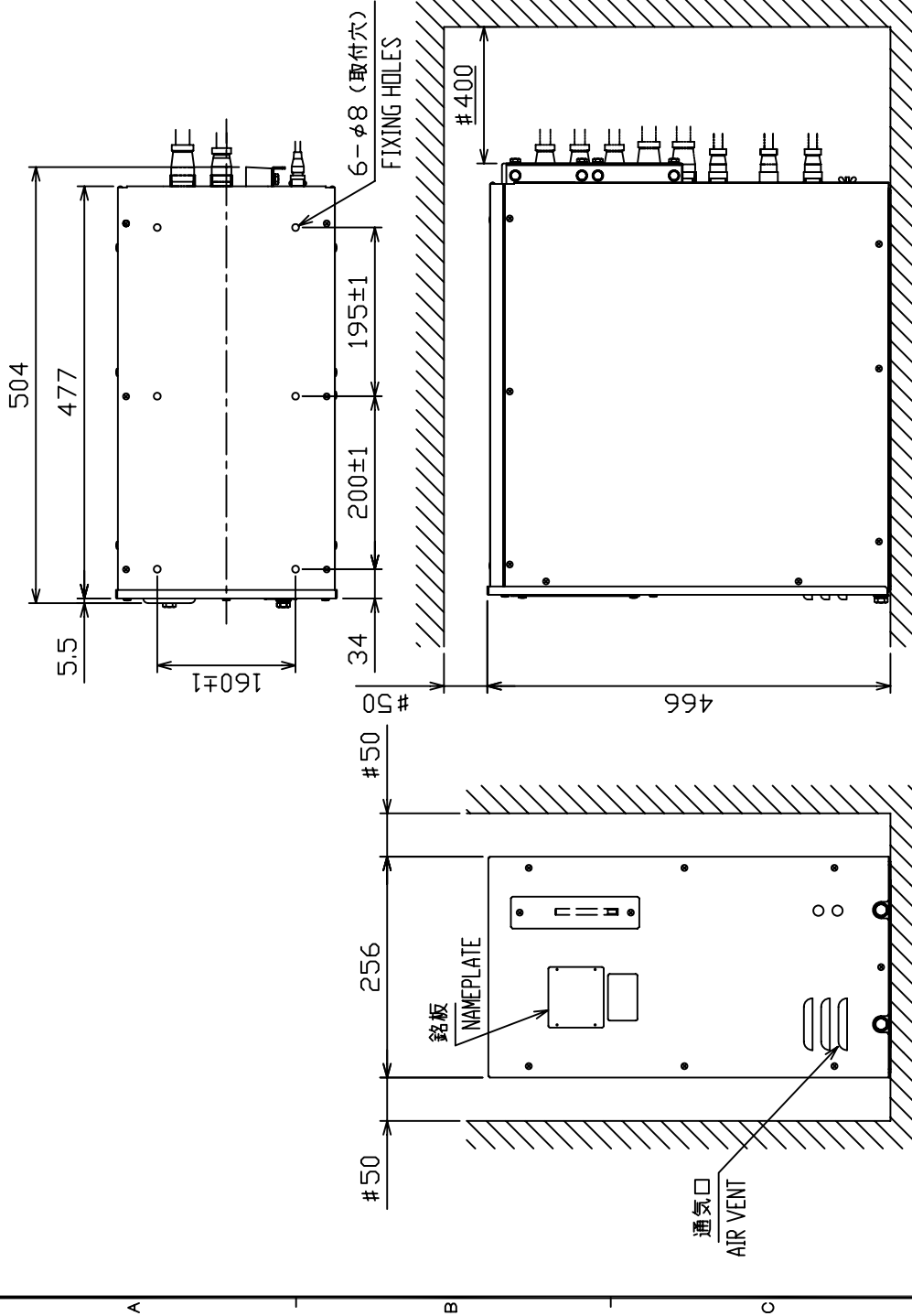

- 注記 1) #印寸法は最小サービスクリアランスとする。
 2) 指定外の寸法公差は表1による。
 3) 取付用ネジはM6ボルトを使用のこと。
 4) 装備ケーブルはサービスクリアランスを前方に十分引き出せるよう余裕を持たせること。

- NOTE 1. # MINIMUM SERVICE CLEARANCE.
 2. TABLE 1 INDICATES TOLERANCE OF DIMENSIONS WHICH IS NOT SPECIFIED.
 3. USE M6 BOLTS FOR FIXING THE UNIT.
 4. KEEP SUFFICIENT CABLE LENGTH BEHIND UNIT.

DRAWN 28.06 E. MIYOSHI	TITLE FSV-2402/2402S/3002/3002S/8402
CHECKED TAKAHASHI, T	名称 制御部
APPROVED Y. Hatai	外寸図
SCALE 1/8 MASS 29.0 kg	NAME PROCESSOR UNIT
DWG No. C1318-602-E	10-079-300G-0
	OUTLINE DRAWING

表 1 TABLE 1

寸法区分 (mm) DIMENSION	公差 (mm) TOLERANCE
L ≤ 50	± 1.5
50 < L ≤ 100	± 2.5
100 < L ≤ 500	± 3
500 < L ≤ 1000	± 4

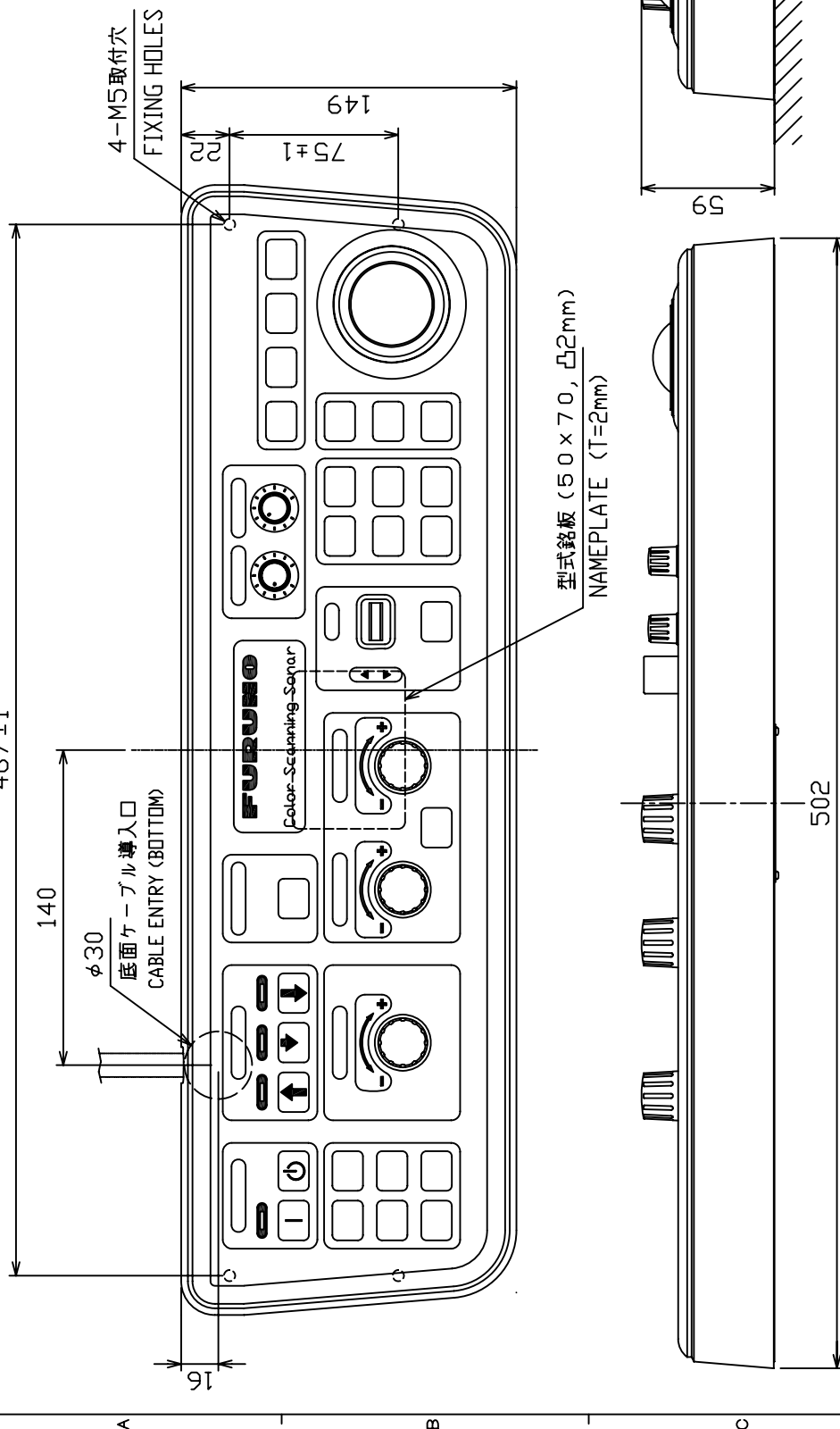

- 注 記 1) #印寸法は最小サービス空間寸法とする。
 2) 指定外の寸法公差は表 1 による。
 3) 質量は、ケーブル (5m) を含む。
 4) 取付用ネジは M5 ボルトを使用のこと。但し、ボルトが内部に 20 mm 以上入り込まないこと。

- NOTE 1. # MINIMUM SERVICE CLEARANCE.
 2. TABLE 1 INDICATES TOLERANCE OF DIMENSIONS WHICH IS NOT SPECIFIED.
 3. MASS W/CABLE (5M).
 4. USE M5 BOLTS FOR FIXING THE UNIT.
 DO NOT FASTEN BOLTS INTO UNIT MORE THAN 20 mm.

DRAWN	Aug. 21.06 Maki	TITLE	FSV-2401/3001/8401
CHECKED	TAKAHASHI, T	名称	操作部 (KB直付け金具なし)
APPROVED	Y. Hatai		外寸図
SCALE	1/3 MASS 3.6 kg 質量はケーブルを含む。 MASS W/CABLE.	NAME	CONTROL UNIT (w/o KB FIXING PLATE)
DWG No.	C1318-G08-E		OUTLINE DRAWING
			10-079-210G-0

表1 TABLE 1

寸法区分 (mm) DIMENSIONS	公差 (mm) TOLERANCE
$L \leq 50$	± 1.5
$50 < L \leq 100$	± 2.5
$100 < L \leq 500$	± 3
$500 < L \leq 1000$	± 4
$1000 < L \leq 2000$	± 5
$2000 < L \leq 4000$	± 7



表2 TABLE 2

	質量 MASS (kg)
上下装置本体 HULL UNIT	690
格納タンク TANK	260
送受波器 (ケーブル含む) TRANSDUCER W/ CABLE	190
総質量 TOTAL	1140

- 注 記
- 1) #印寸法は最小サービス空間寸法とする。
 - 2) 指定外の寸法公差は表1による。
 - 3) 質量は表2による。
 - 4) 取付はM20ボルト及びナットを使用のこと。

- NOTE
1. # MINIMUM SERVICE CLEARANCE.
 2. TABLE 1 INDICATES TOLERANCE OF DIMENSIONS WHICH IS NOT SPECIFIED.
 3. MASS SEE TABLE 2.
 4. USE M20 BOLTS AND NUTS FOR FIXING THE UNIT.

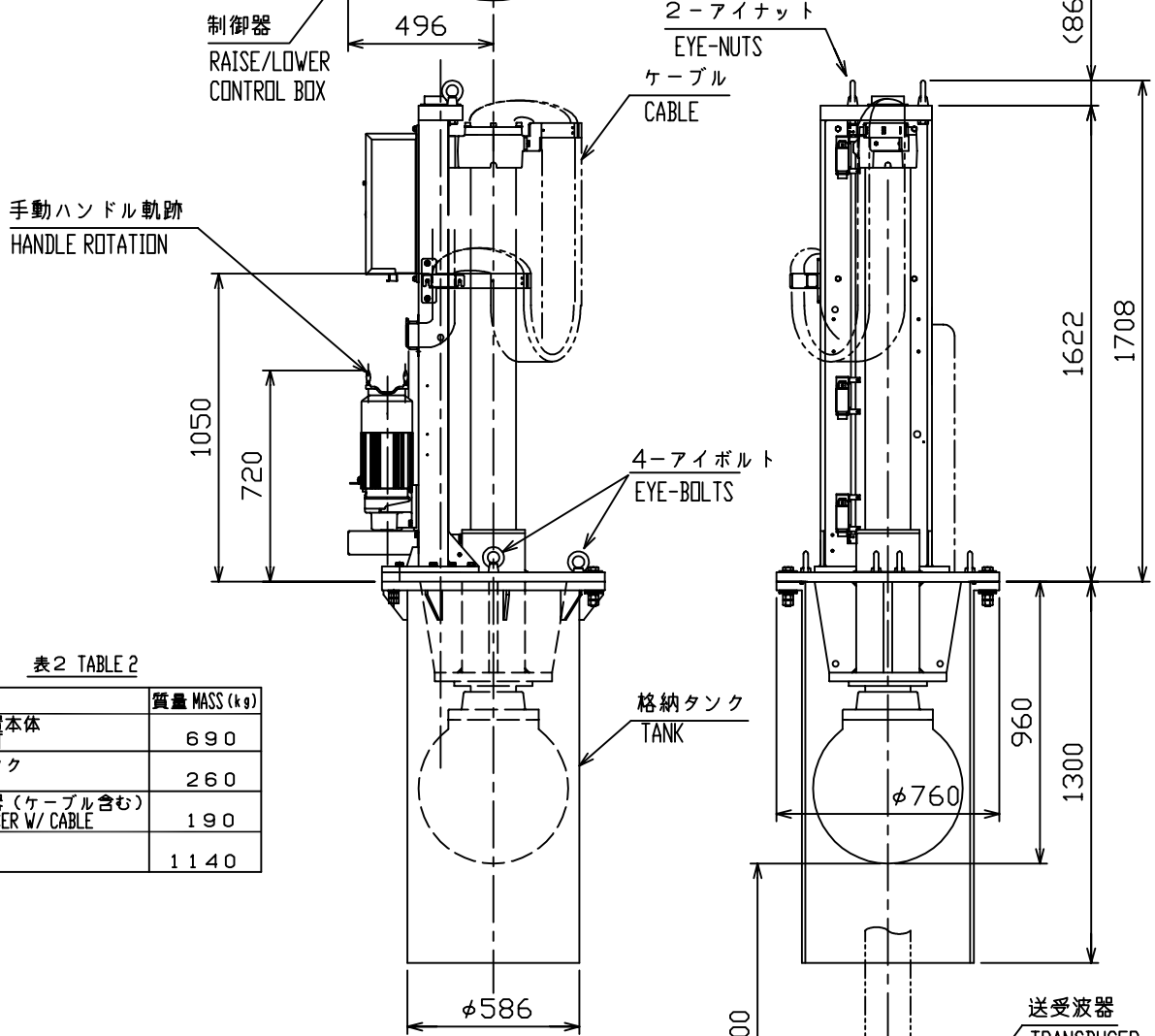
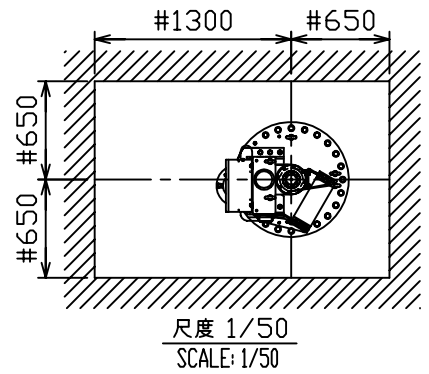
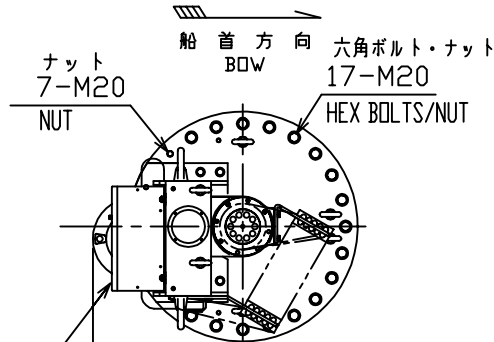
DRAWN Dec 10 '03 E.MIYOSHI		TITLE FSV-303
CHECKED		名称 上下装置 (1200mmストローク)
APPROVED Y. Hatai	FSV-30	外寸図
SCALE 1/25	MASS 表2参照 SEE TABLE 2	NAME HULL UNIT (1200mm TRAVEL)
DWG.No. C1323-G01-B	10-079-500G-2	OUTLINE DRAWING



表1 TABLE 1

寸法区分 (mm) DIMENSION	公差 (mm) TOLERANCE
$L \leq 50$	± 1.5
$50 < L \leq 100$	± 2.5
$100 < L \leq 500$	± 3
$500 < L \leq 1000$	± 4
$1000 < L \leq 2000$	± 5
$2000 < L \leq 4000$	± 7

表2 TABLE 2

	質量 MASS (kg)
上下装置本体 HULL UNIT	740
格納タンク TANK	260
送受波器 (ケーブル含む) TRANSDUCER W/ CABLE	190
総質量 TOTAL	1190

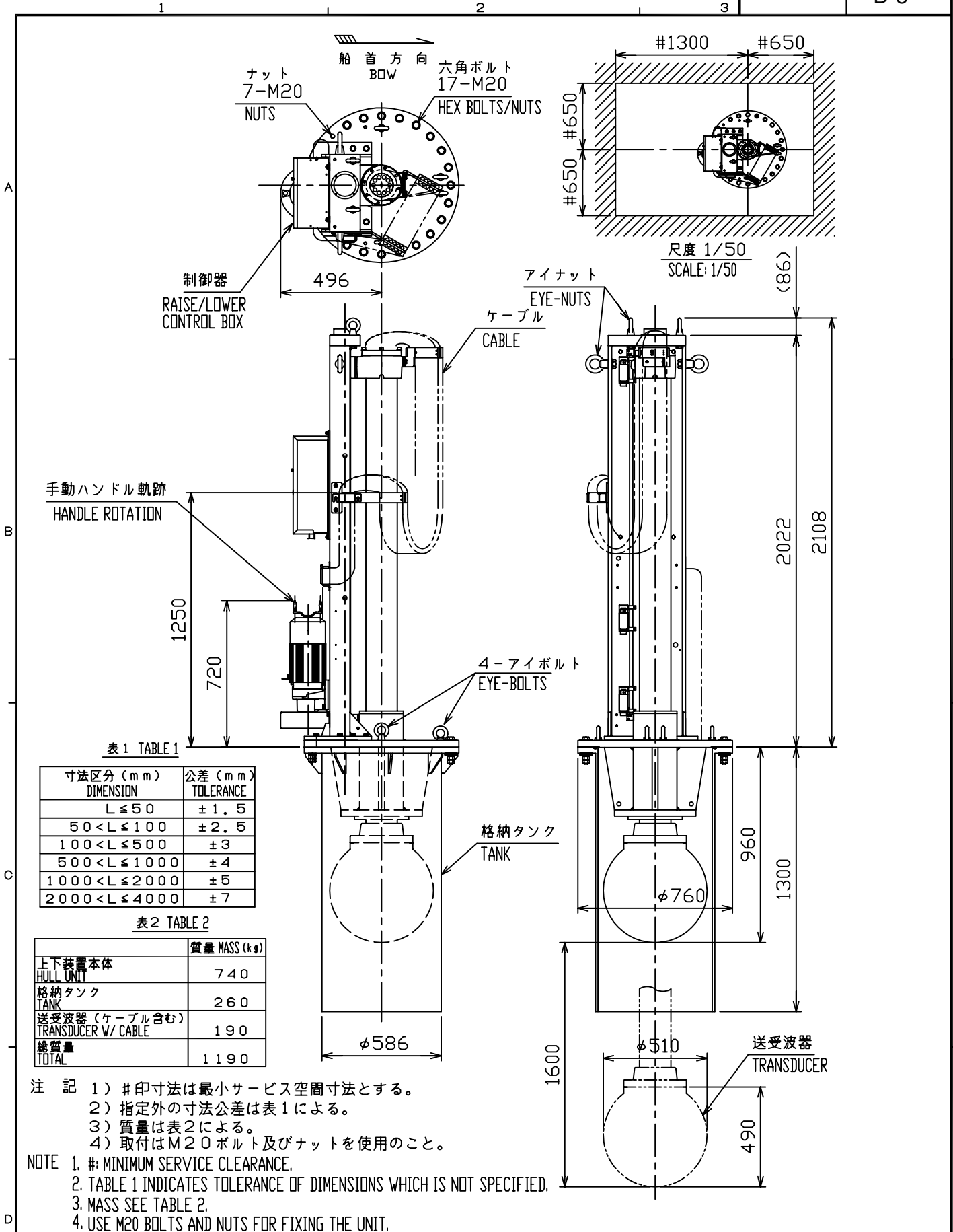
注記 1) #印寸法は最小サービス空間寸法とする。
 2) 指定外の寸法公差は表1による。
 3) 質量は表2による。
 4) 取付はM20ボルト及びナットを使用のこと。

NOTE 1. #: MINIMUM SERVICE CLEARANCE.
 2. TABLE 1 INDICATES TOLERANCE OF DIMENSIONS WHICH IS NOT SPECIFIED.
 3. MASS SEE TABLE 2.
 4. USE M20 BOLTS AND NUTS FOR FIXING THE UNIT.

DRAWN Dec 10 '03 E.MIYOSHI	TITLE FSV-304
CHECKED	名称 上下装置 (1600mmストローク)
APPROVED Y. Hatai	外寸図
SCALE 1/25	NAME HULL UNIT (1600mm TRAVEL)
DWG.No. C1323-G02-B	10-079-510G-2 OUTLINE DRAWING

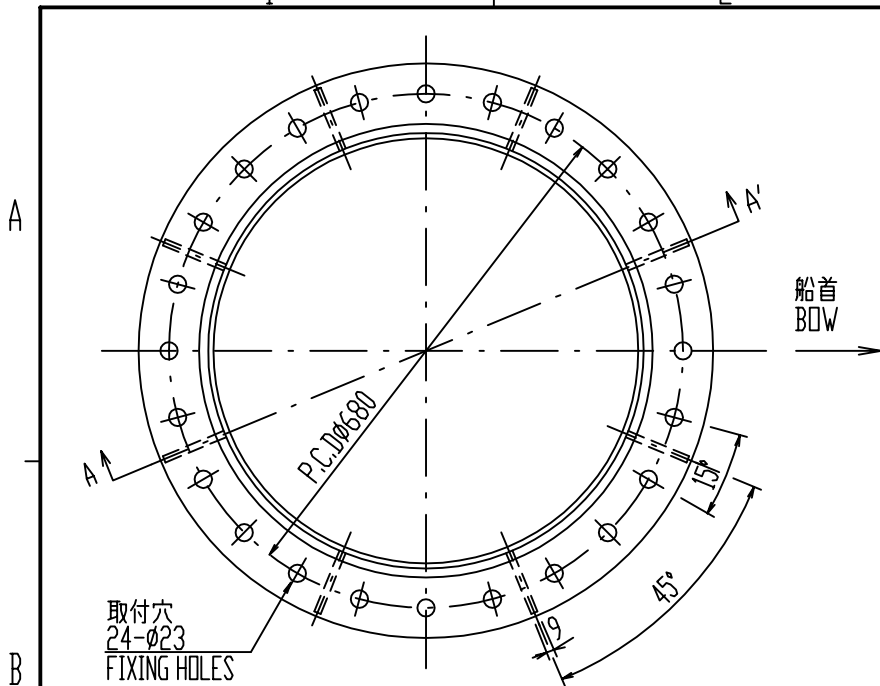

注記

1) 装備時24個のボルト穴のうち適当な1個を船首方向に一致させる。

NOTE

1. ONE OF 24 BOLT HOLES SHOULD BE FACED DEAD AHEAD.

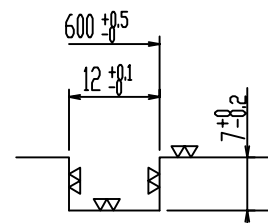
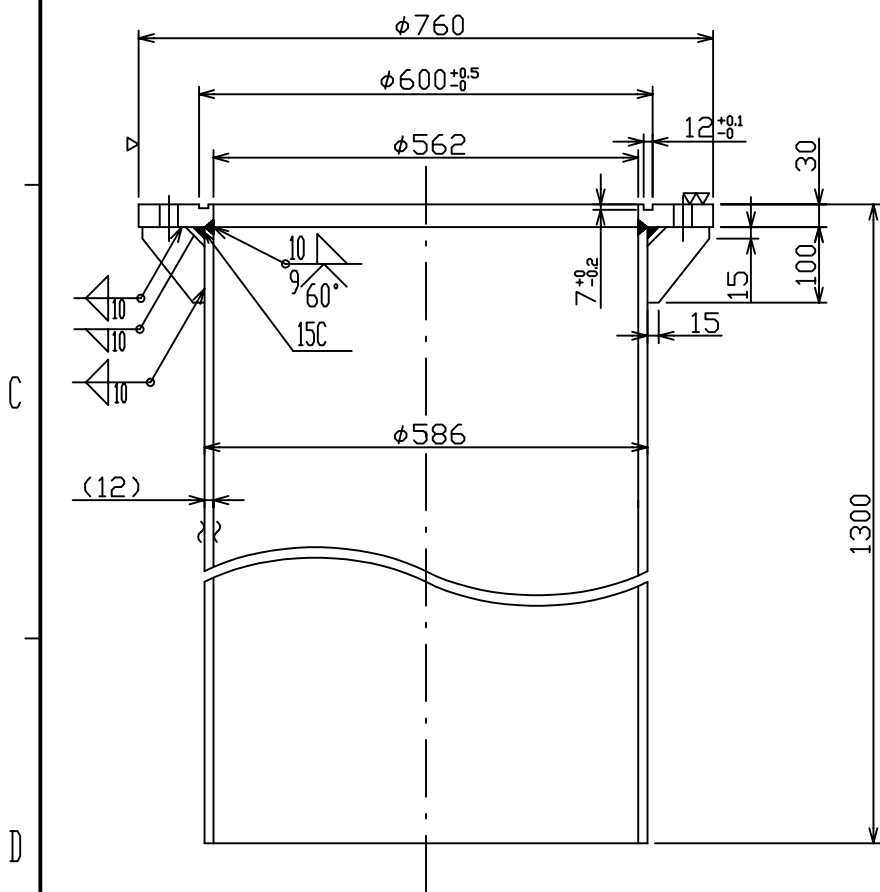

○リング溝の仕上げ図
FINISHING OF O-RING GROOVE
(尺度 SCALE 1/1)

A-A' 断面図
SECTION A-A'

DRAWN Aug. 22 '03 H.MAKI		TITLE 10-077-5501
CHECKED Takahashi T.		名称 格納タンク
APPROVED Y. Hatai	FSV-24/30	外寸図
SCALE 1/10	MASS 260 $\pm 10\%$ kg	NAME RETRACTION TANK
DWG.No. C1318-G16-B	10-077-5501-0	OUTLINE DRAWING

表 1 TABLE 1

寸法区分(mm) DIMENSIONS	公差(mm) TOLERANCE
0 < L ≤ 50	±1.5
50 < L ≤ 100	±2.5
100 < L ≤ 500	±3
500 < L ≤ 1000	±4

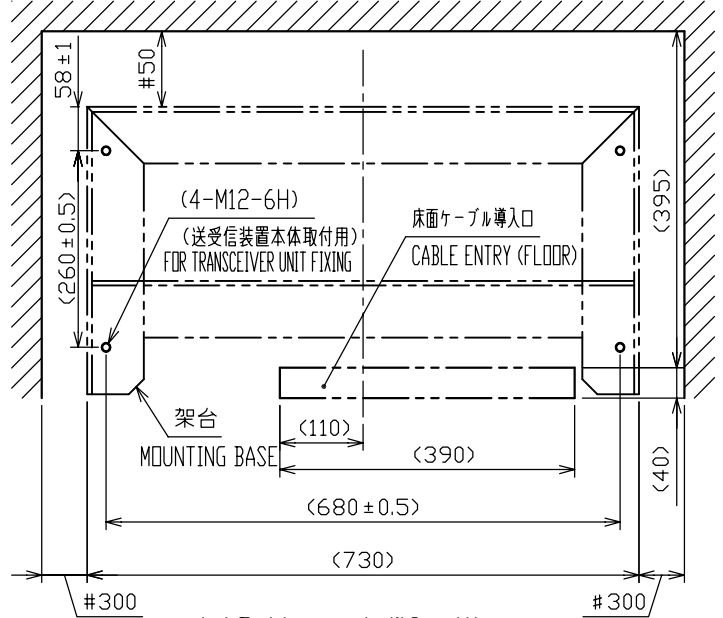
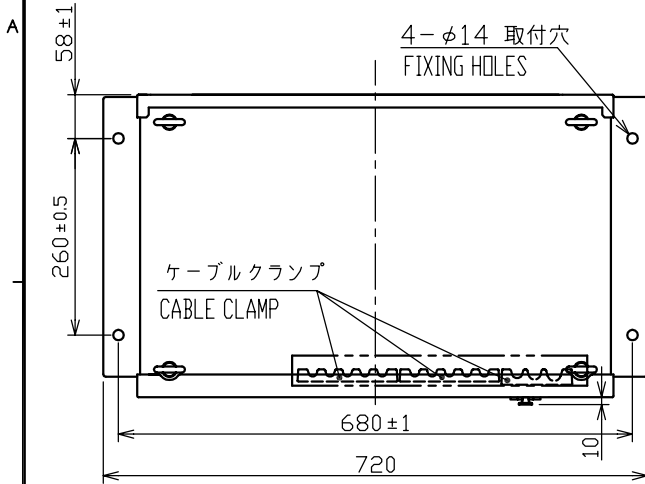

架台及び床面ケーブル導入口寸法図
MOUNTING BASE AND CABLE ENTRY DIMENSIONS

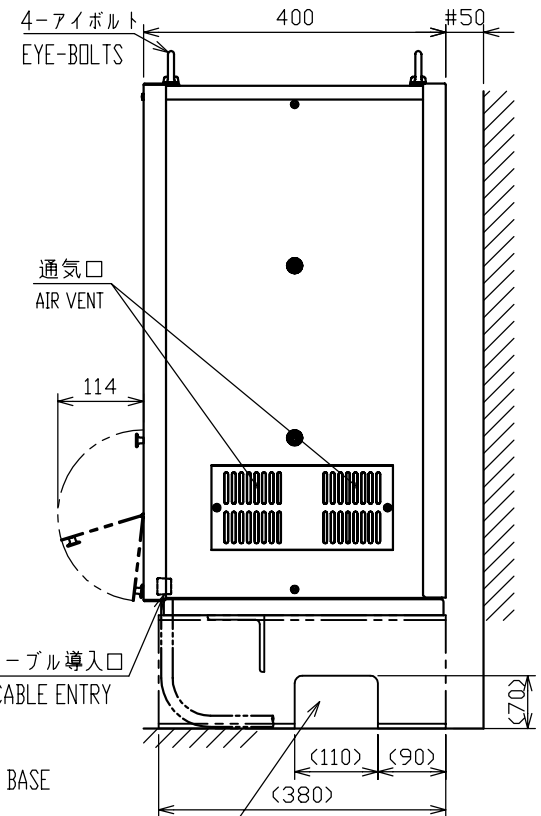
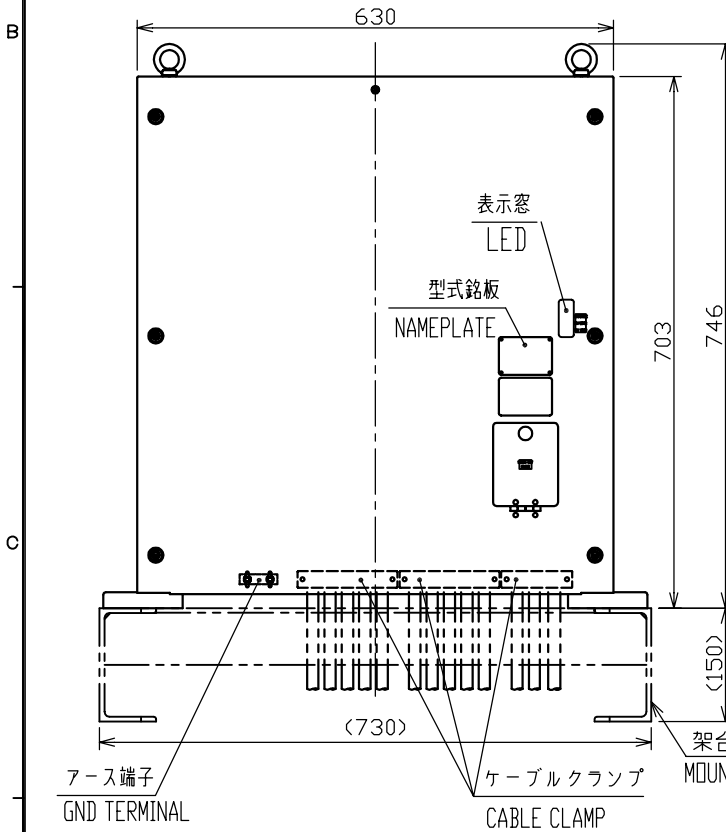

ケーブル導入口 (架台) / CABLE ENTRY (MOUNTING BASE)
(手前側あるいは反対側) (THIS SIDE OR OPPOSITE SIDE)

注 記

- 1) #印寸法は最小サービス空間寸法とする。
- 2) 指定外の寸法公差は表 1 による。
- 3) 取付用ネジは M12 ボルト (材質: SUS304) を使用のこと。
- 4) 架台及び床面ケーブル導入口の寸法は参考寸法とする。
直接床置きの場合のみ床面ケーブル導入口を設け、架台取付けの場合架台は造船所手配とする。(架台材質: SS400)

NOTE

1. # MINIMUM SERVICE CLEARANCE.
2. TABLE 1 INDICATES TOLERANCE OF DIMENSIONS WHICH IS NOT SPECIFIED.
3. USE M12 BOLTS FOR FIXING THE UNIT.
4. DIMENSIONS OF MOUNTING BASE AND CABLE ENTRY ARE REFERENCE ONLY. A MOUNTING BASE (SS400) SHOULD BE SUPPLIED BY SHIPYARD. MAKE A CABLE ENTRY ON THE FLOOR WHEN THE MOUNTING BASE IS NOT USED.

DRAWN Dec 17 '03 E. MIYOSHI		TITLE FSV-301
CHECKED Takahashi T.		名称 送受信装置
APPROVED Y. Hatai	FSV-30/30S	外寸図
SCALE 1/10	MASS 98 ±10% kg	NAME TRANSCEIVER UNIT
DWGNo. C1323-G03-B	10-079-600G-1	OUTLINE DRAWING



表1 TABLE 1

寸法区分 (mm) DIMENSIONS	公差 (mm) TOLERANCE
L ≤ 50	± 1.5
50 < L ≤ 100	± 2.5
100 < L ≤ 500	± 3
500 < L ≤ 1000	± 4

注記

- 1) #印寸法は最小サービス空間寸法とする。
- 2) 指定外の寸法公差は表1による。
- 3) 取付はM6ボルトを使用のこと。

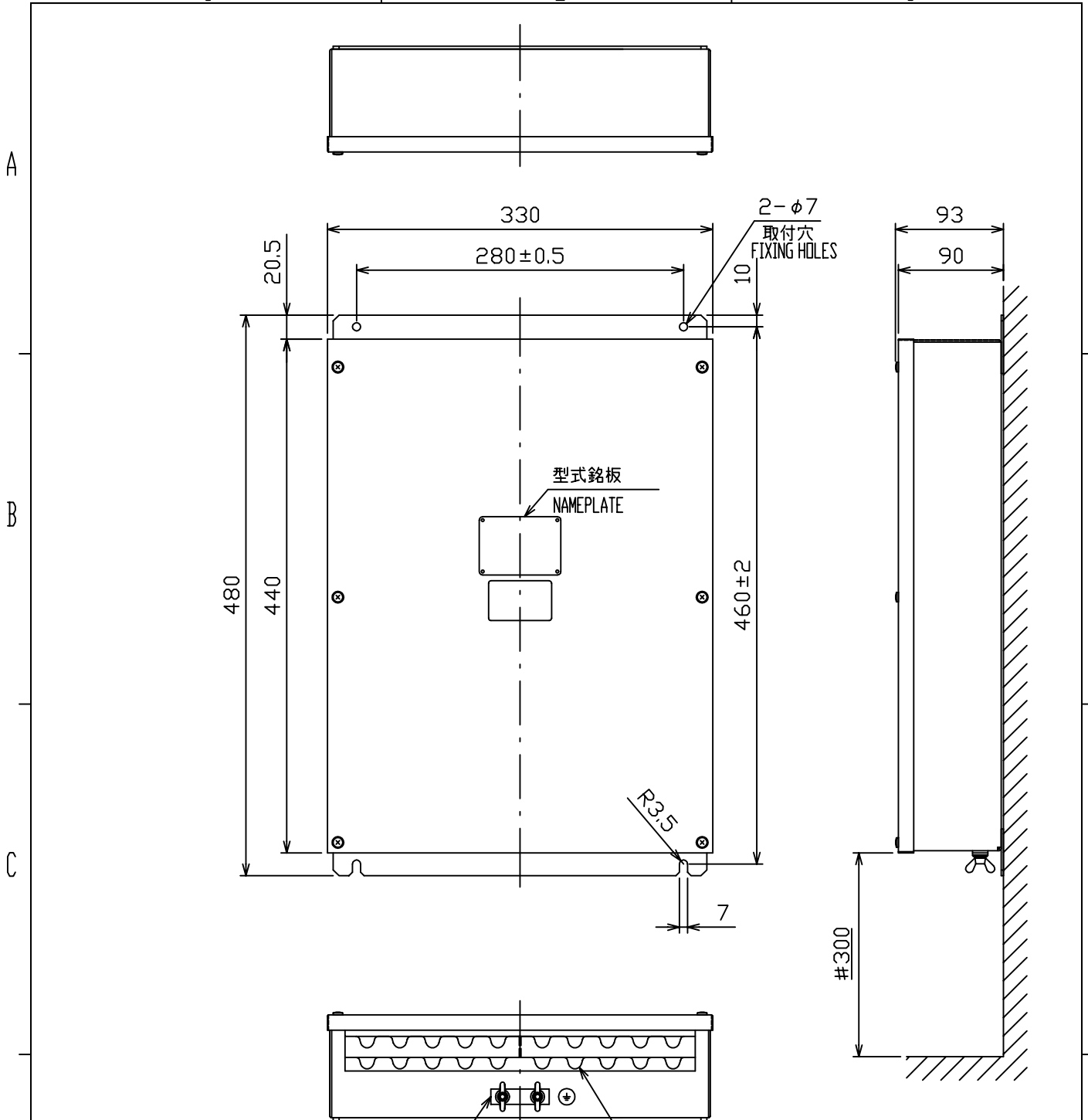
NOTE

1. #: MINIMUM SERVICE CLEARANCE.
2. TABLE 1 INDICATES TOLERANCE OF DIMENSIONS WHICH IS NOT SPECIFIED.
3. FIX WITH M6 BOLTS.

DRAWN	Dec. 7 '03 E. MIYOSHI	TITLE	FSV-305
CHECKED		名称	接続箱
APPROVED	Y. Hatai	FSV-30/30S	外寸図
SCALE	1/5	MASS	7.5 ± 10% kg
DWG.No.	C1323-G04-B	10-079-700G-1	NAME JUNCTION BOX OUTLINE DRAWING

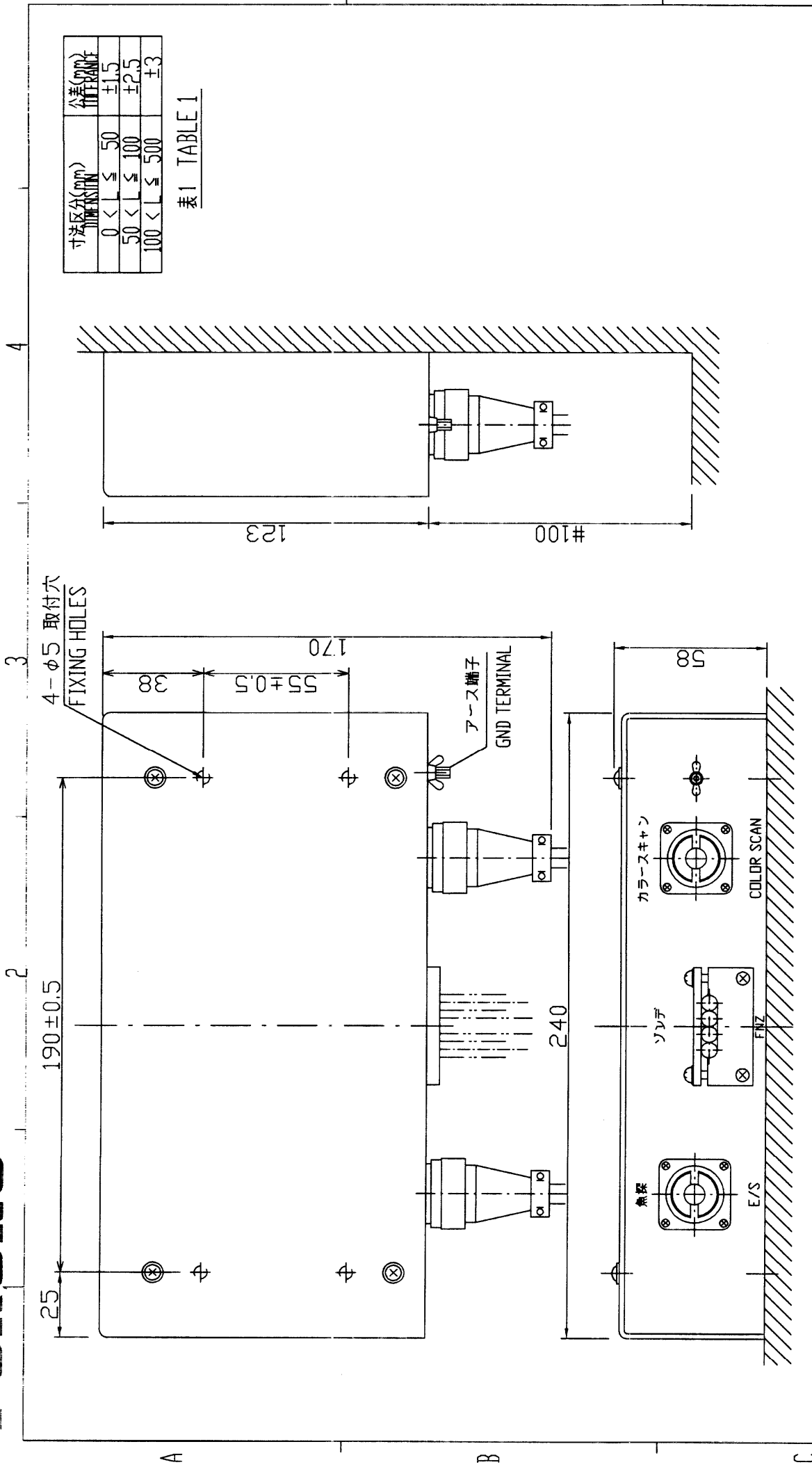

DRAWN JUL 11 '01 T. YAMASAKI	TITLE CS-170
CHECKED Tsub Y. K.	名称 ネットゾンデ接続箱
APPROVED Tsub Y. K.	外寸図
SCALE 1/2	NAME NET JOINT BOX
MASS 2 ±10% kg	OUTLINE DRAWING
DWG.No. C1233-007-D	

注記

- 1) 推梁する最小サービス空間寸法。
- 2) 指定なき寸法公差は表1による。

NOTE

1. # RECOMMENDED SERVICE CLEARANCE.
2. TABLE 1 INDICATES TOLERANCE OF DIMENSIONS.

表1 TABLE 1

寸法区分(mm) DIMENSIONS	公差(mm) TOLERANCE
$0 < L \leq 50$	± 1.5
$50 < L \leq 100$	± 2.5
$100 < L \leq 500$	± 3

A

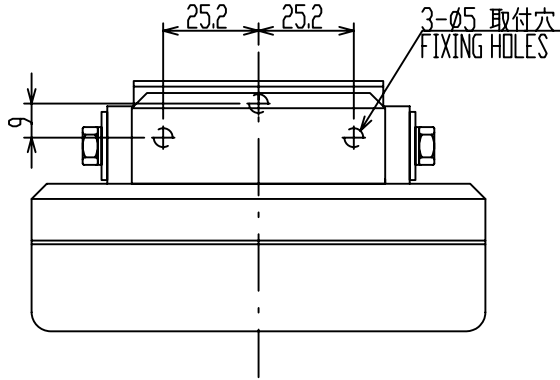

B

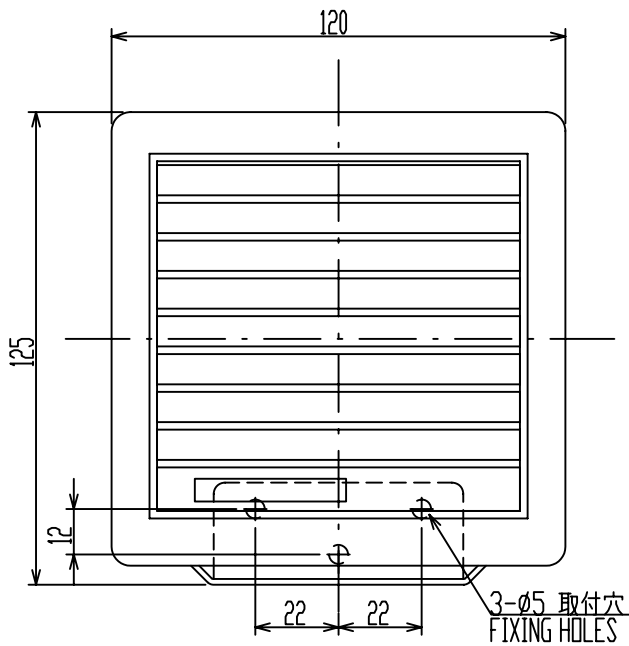

C

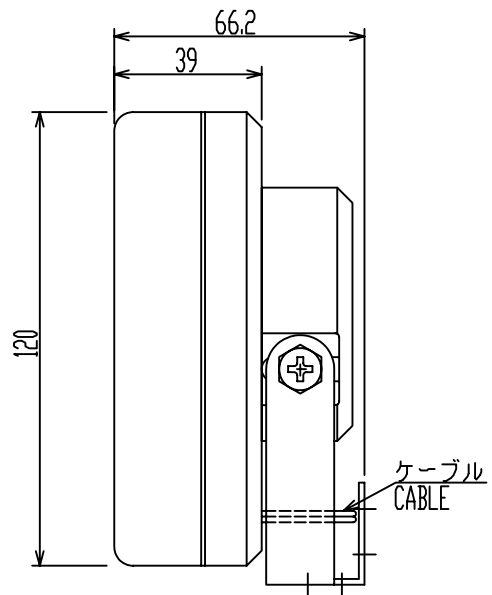

D

注記 1) 指定外寸公差は表1による。

NOTE 1. TABLE 1 INDICATES TOLERANCE OF DIMENSIONS WHICH IS NOT SPECIFIED.

DRAWN	Nov. 25, '06	E. MIYOSHI	TITLE	SEM-21Q
CHECKED		TAKAHASHI, T	名称	スピーカ
APPROVED		Y. Hatai		外寸図
SCALE	1/2	MASS 0.54 ±10% kg	質量は2.8mケーブルを含む MASS W/ 2.8m CABLE	NAME
DWG.No.	C5016-G07-C	REF.No.		LOUDSPEAKER
				OUTLINE DRAWING

This page is intentionally left blank.

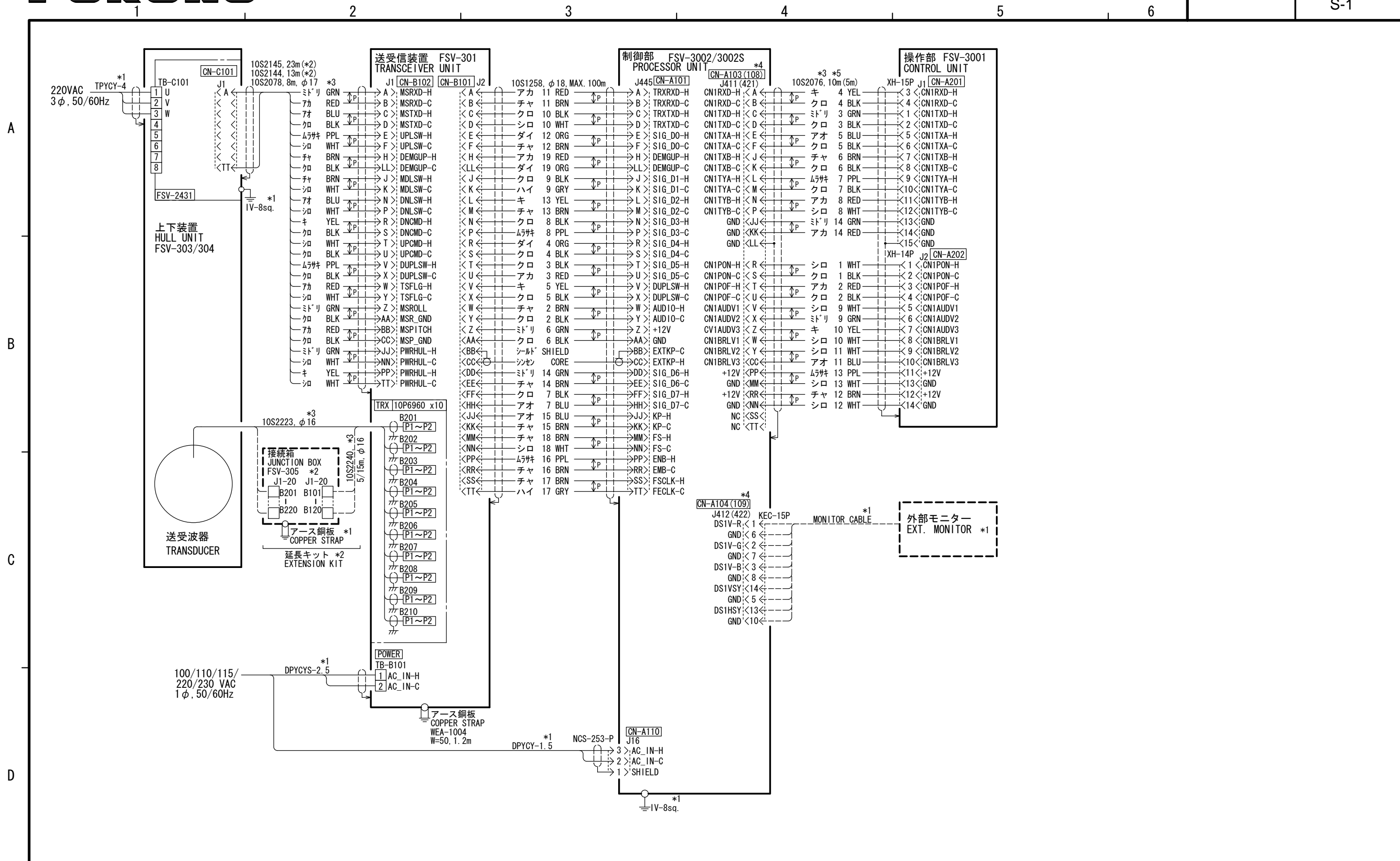

注記
 * 1) 造船所手配
 * 2) オプション。
 * 3) コネクタは工場にて取付済み。
 * 4) (): 副表示部/副操作部用。
 * 5) 和文仕様では5/10mより選択。

NOTE
 *1: SHIPYARD SUPPLY.
 *2: OPTION.
 *3: CONNECTOR PLUGS FITTED AT FACTORY.
 *4: (): FOR SUB-MONITOR OR SUB-CONTROL.
 *5: 5m CABLE AVAILABLE FOR JAPANESE ONLY.

DRAWN	9/Jul/08 T. YAMASAKI	TITLE	FSV-30/30S
CHECKED	9/Jul/08 T. TAKENO	名称	カラーキャニングソナー
APPROVED	18/Jul/08 R. Esumi		相互結線図
SCALE	MASS kg	NAME	COLOR SCANNING SONAR
DWG No.	C1323-C02-D		INTERCONNECTION DIAGRAM

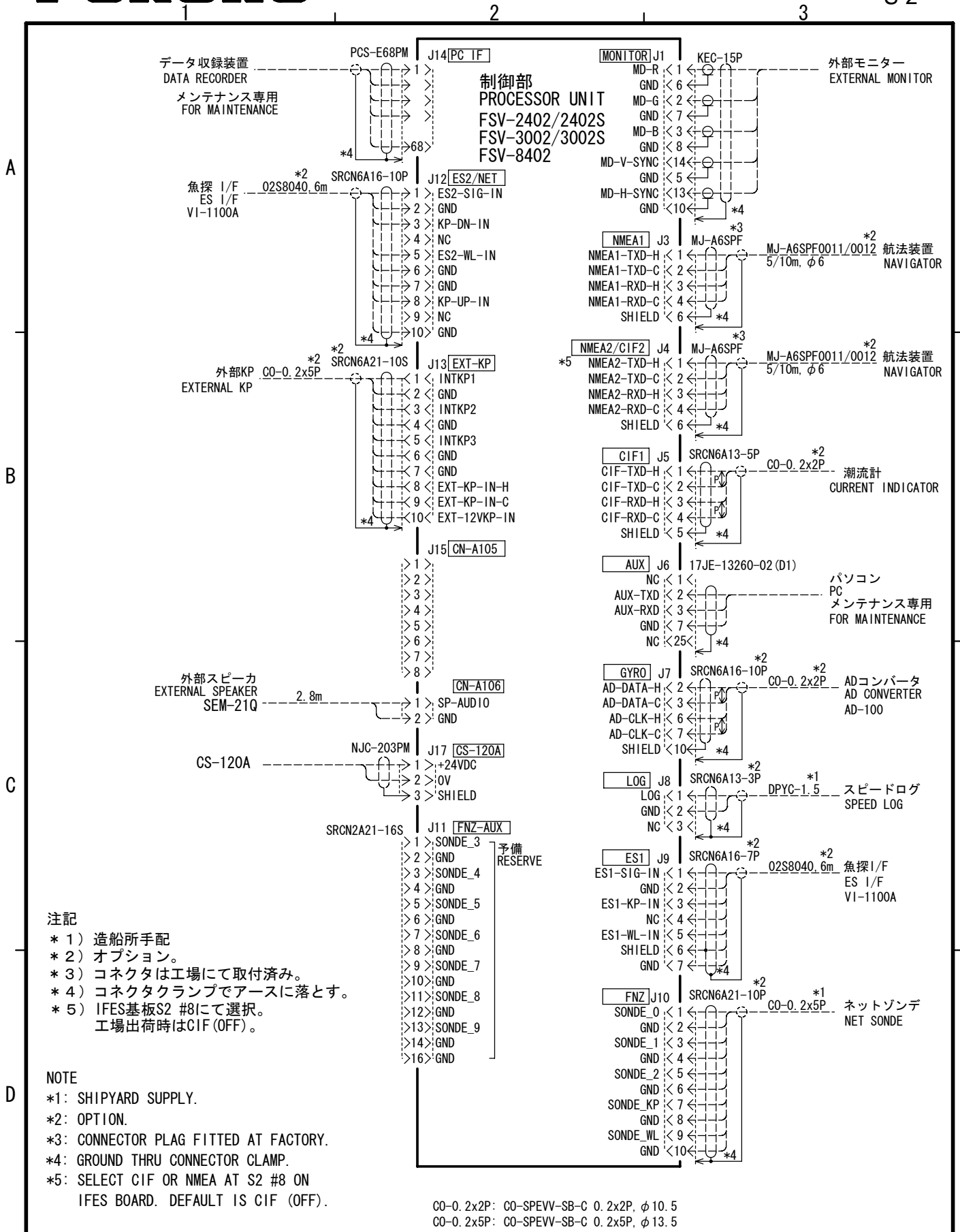

DRAWN Dec. 26 '06 E. MIYOSI	TITLE FSV-2402/2402S/3002/3002S/8402
CHECKED TAKAHASHI. T	名称 制御部外部信号接続
APPROVED Y. Hatai	相互結線図
SCALE MASS kg	NAME PROCESSOR UNIT EXTERNAL INTERFACE
DWG. No. C1318-C03- N	INTERCONNECTION DIAGRAM