

FURUNO

OPERATOR'S MANUAL

COLOR MULTI-SECTOR SONAR

MODEL CH-36



FURUNO ELECTRIC CO., LTD.
NISHINOMIYA, JAPAN

© **FURUNO ELECTRIC CO., LTD.**

9-52, Ashihara-cho,
Nishinomiya, Japan 662

Telephone: 0798-65-2111
Telefax: 0798-65-4200 (G111)

All rights reserved. Printed in Japan

·Your Local Agent/Dealer

Initial : MAY 1992
E : DEC. 9, 1996

(ETMI)

PUB. No. OME-12830
CH-36



* 0 0 0 8 0 3 1 8 2 0 0 *



SAFETY INSTRUCTIONS

"DANGER", "WARNING" and "CAUTION" notices appear throughout this manual. It is the responsibility of the operator of the equipment to read, understand and follow these notices. If you have any questions regarding these safety instructions, please contact a FURUNO agent or dealer.



DANGER

This notice indicates a potentially hazardous situation which, if not avoided, will result in death or serious injury.



WARNING

This notice indicates a potentially hazardous situation which, if not avoided, could result in death or serious injury.



CAUTION

This notice indicates a potentially hazardous situation which, if not avoided, could result in minor or moderate injury, or property damage.

WARNING



Do not open the cover of the equipment.

This equipment uses high voltage electricity which can shock burn, or cause death. Only qualified personnel should work inside the equipment.

Do not disassemble or modify the equipment.

Fire, electrical shock or serious injury can result.

Immediately turn off the power at the ship's mains switchboard if water or foreign object falls into the equipment or the equipment is emitting smoke or fire.

Continued use of the equipment can cause fire or electrical shock or serious injury.

CAUTION

Use the proper fuse.

Do not place liquid-filled containers on the top of the equipment.

Do not place liquid-filled containers on the top of the equipment.

Fire or electrical shock can result if a liquid spills into the equipment.

Do not place liquid-filled containers on the top of the equipment.

Heat can melt the power cord, which can result in fire or electrical shock.

Do not operate the unit with wet hands.

Electrical shock may result.

Observe maximum allowable ship's speed of 18 knots during operation and 15 knots while raising/lowering transducer.

The zinc block attached near the transducer must be replaced yearly.

The junction between the transducer and main shaft may corrode, which can result in loss of the transducer or water leakage inside the ship.

When manually raising or lowering transducer with hand crank, ship's mains should be supplied to the hull unit and turn socket wrench while pressing the brake-off switch. Otherwise the magnetic brake of the raise/lower motor operates, disabling the manual raise/lower.

Table of Contents

FOREWORD	1
FEATURES	1
SYSTEM CONFIGURATION	2
CHAPTER 1. CONTROLS AND FUNCTIONS	1-1
1-1. MAIN PANEL.....	1-1
1-2. SUB-PANEL	1-2
1-3. PRESENTATION MODE.....	1-3
CHAPTER 2. SONAR MODE OPERATION	2-1
2-1. PROCEDURE.....	2-1
Range Selection.....	2-2
SECTOR Selection.....	2-2
Setting the Tilt Angle.....	2-3
Gain Setting	2-6
Rejecting Sonar Interference and Noise	2-6
Detecting Fish Schools Aurally	2-7
Using R/B Mark and Event Mark (trackball operation).....	2-8
Selecting Training Sector Quickly.....	2-9
2-2. FINE TUNING THE PICTURE.....	2-10
Suppressing Seabed and Sea Surface Reflections in Shallow Fishing Grounds	2-10
Suppressing Seabed Tail	2-10
Displaying Surface Fish Clearly (applying proper TVG)	2-10
Relocating Fish School for Easy Observation.....	2-12
Finding Fish School Center.....	2-12
2-3. MENU SCREENS	2-13
Operating Procedure.....	2-13
Sonar Menu.....	2-13
2-4. INTERPRETING THE DISPLAY.....	2-15
How the Picture is Painted.....	2-15
Seabed	2-16
Fish School	2-17
Sea Surface Reflections	2-18
Wake	2-18
False Echo by Sidelobe.....	2-19
Noise and Interference	2-19
2-5. INDICATIONS ON THE SCREEN	2-20
Normal Sonar Display	2-20
Expanded Sonar Display.....	2-21
2-6. EXAMPLES OF APPLICATION	
CHAPTER 3. VERTICAL FAN MODE OPERATION	3-1
3-1. OBTAINING PROCEDURE.....	3-1

Range Selection.....	3-2
Selecting the Bearing of the Vertical Fan	3-3
Selecting the Display Sector (center and width).....	3-4
Auto Shift of the Own Ship's Position.....	3-4
Rejecting Sonar Interference and Noise.....	3-5
Using Horizontal Mark, Vertical Mark and Event Mark (trackball operation)	3-5
3-2. FINE TUNING THE PICTURE.....	3-7
Applying a Proper TVG.....	3-7
3-3. MENU SCREEN.....	3-8
Operating Procedure.....	3-8
Bottom/3D Menu (vertical fan mode)	3-8
3-4. INTERPRETING THE DISPLAY.....	3-9
How the Picture is Painted.	3-9
Port-starboard Picture (seabed).....	3-11
The Ship is passing over fish schools.....	3-11
Display of Net Hauling.....	3-12
False Echo	3-12
3-5. INDICATIONS ON THE SCREEN	3-13
Vertical Fan Mode.....	3-13
3-6. EXAMPLE OF APPLICATION.....	3-14
CHAPTER 4. USING CUSTOM MODE KEY.....	4-1
4-1. USING THE CUSTOM KEYS.....	4-1
CHAPTER 5. MAINTENANCE AND GENERAL NOTES	5-1
5-1. DISPLAY UNIT	5-1
5-2. TRANSCIVER UNIT	5-1
5-3. HULL UNIT.....	5-1
Lubrication	5-1
Cleaning Retraction Tank (removal of marine growth)	5-2
Replacement of the Grease Cotton Rings.....	5-3
CHAPTER 6. TROUBLESHOOTING	6-1
6-1. SELF-CHECK.....	6-1
Turning on and off Self-check.....	6-1
Description of Self-checks	6-2
6-2. ERROR MESSAGES.....	6-4
6-3. TROUBLESHOOTING	6-7
SPECIFICATIONS	SPC-1
COMPLETE SET	SPC-5
STANDARD SUPPLY.....	SPC-5
OPTION.....	SPC-5
HULL UNIT ASSEMBLY COMBINATION.....	SPC-6

APPENDIX

A. CHANGING SPECIFICATIONS..... AP-1

B. SYSTEM MENU SETTING AP-2

C. E/S MENU SETTING..... AP-4

D. LIST OF SPECIAL KEY OPERATION AP-5

E. MEMO-PAD FOR CUSTOM KEY AP-6

F. CHARACTERISTICS OF THE ULTRASONIC WAVE IN WATER..... AP-7

HANDLING PRECAUTIONS

Keep all magnetic materials away.

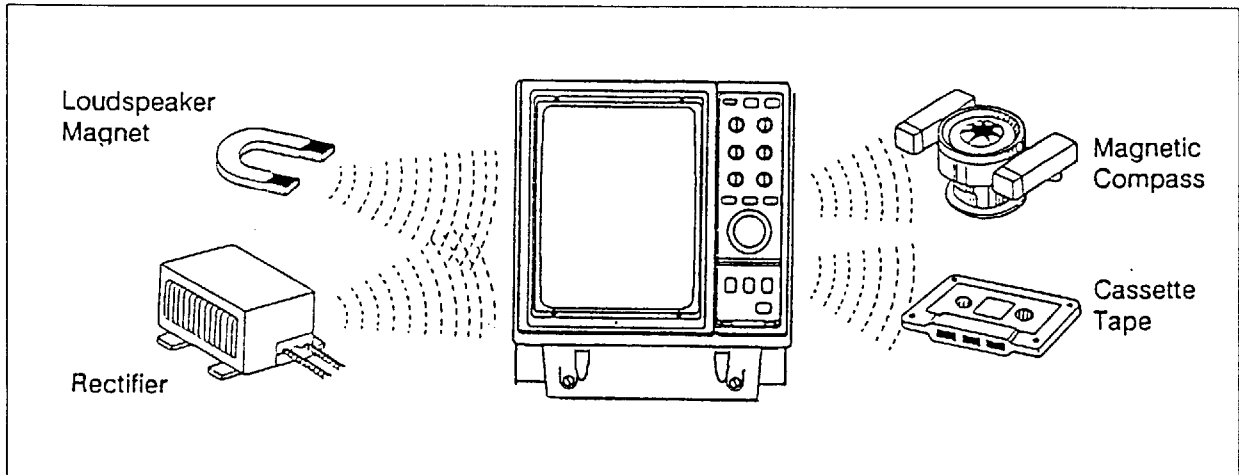

Allow service and ventilation space.

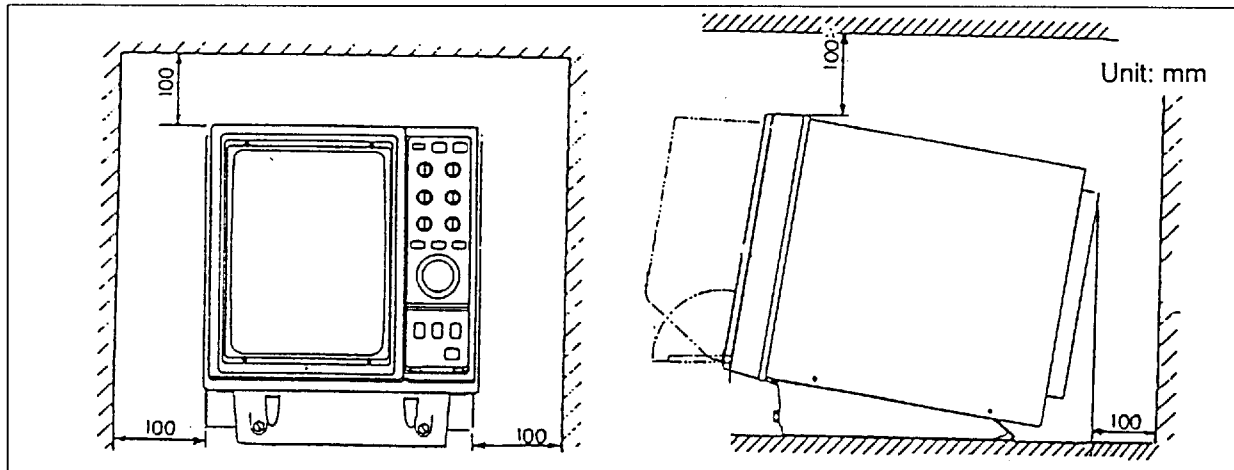

Do not increase brightness too much.

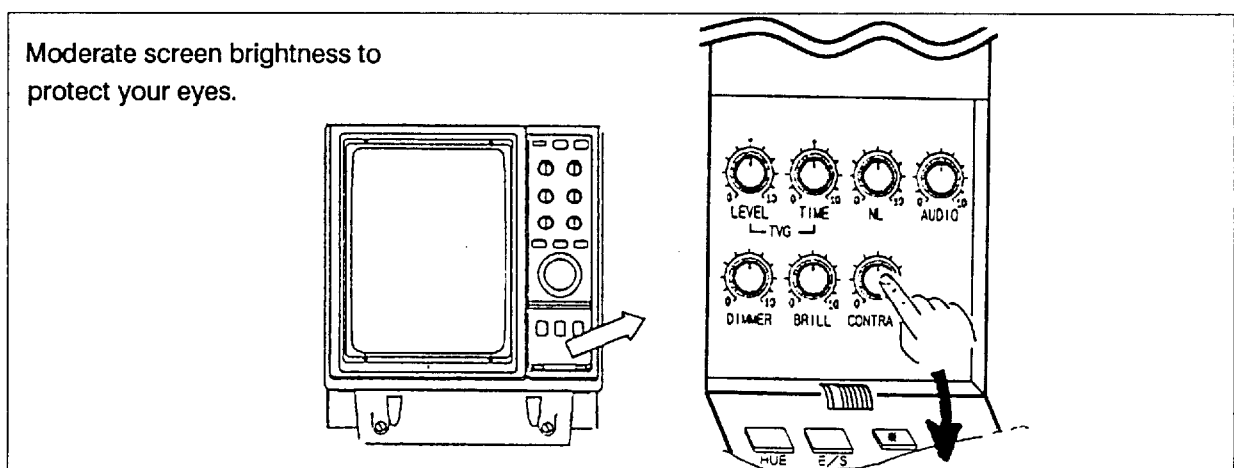

NOTE:
The CH-36 retracts the soundome automatically when the power is turned off, even if the soundome is not retracted. Note however that if you turn off the main power switch first, the soundome cannot be retracted.

FOREWORD

Congratulations on your choice of the FURUNO CH-36 Color Multi Sector Sonar! We are confident that you will enjoy many years of trouble-free operation with this fine piece of equipment.

For over 40 years FURUNO Electric Company has enjoyed an enviable reputation for quality and reliability throughout the world. This dedication to excellence is furthered by our extensive global network of agents and dealers.

The CH-36 is the newest addition to FURUNO's CH family of sonars. This new sonar is especially designed to provide faster detection capability by sector scanning method and improved operation by rotary controls and trackball. The sonar picture is presented in 16 or 8 colors on a high resolution CRT. The excellent signal processing technique and improved receiver bring you a clear and high-quality picture on a 14-inch screen.

We would appreciate feedback from you, the end-user, about whether we are achieving our purpose.

Thank you for considering and purchasing FURUNO equipment.

FEATURES

- Multi sector scanning provides quick coverage of full 360 degree area in just 8 transmissions.
- PPI operation can be selected for superior detection range and bottom fish sounding.
- CUSTOM key provides desired sonar settings by one key stroke.
- Displays a bright, non-fading steady picture in 16- or 8-color presentation on a high resolution 14" CRT.
- Selectable background color lessens eyefatigue in both daytime and nighttime operations.
- Selection of frequencies — 60kHz/1.0kW or 162kHz/1.5kW.
- Trackball offers easy-to-use operation for marker settings.
- Quick training and quick raise/lower operation. (3 times faster than early FURUNO models)
- Vertical mode presents a vertical section of underwater.

SYSTEM CONFIGURATION

The CH-36 consists of the following units.

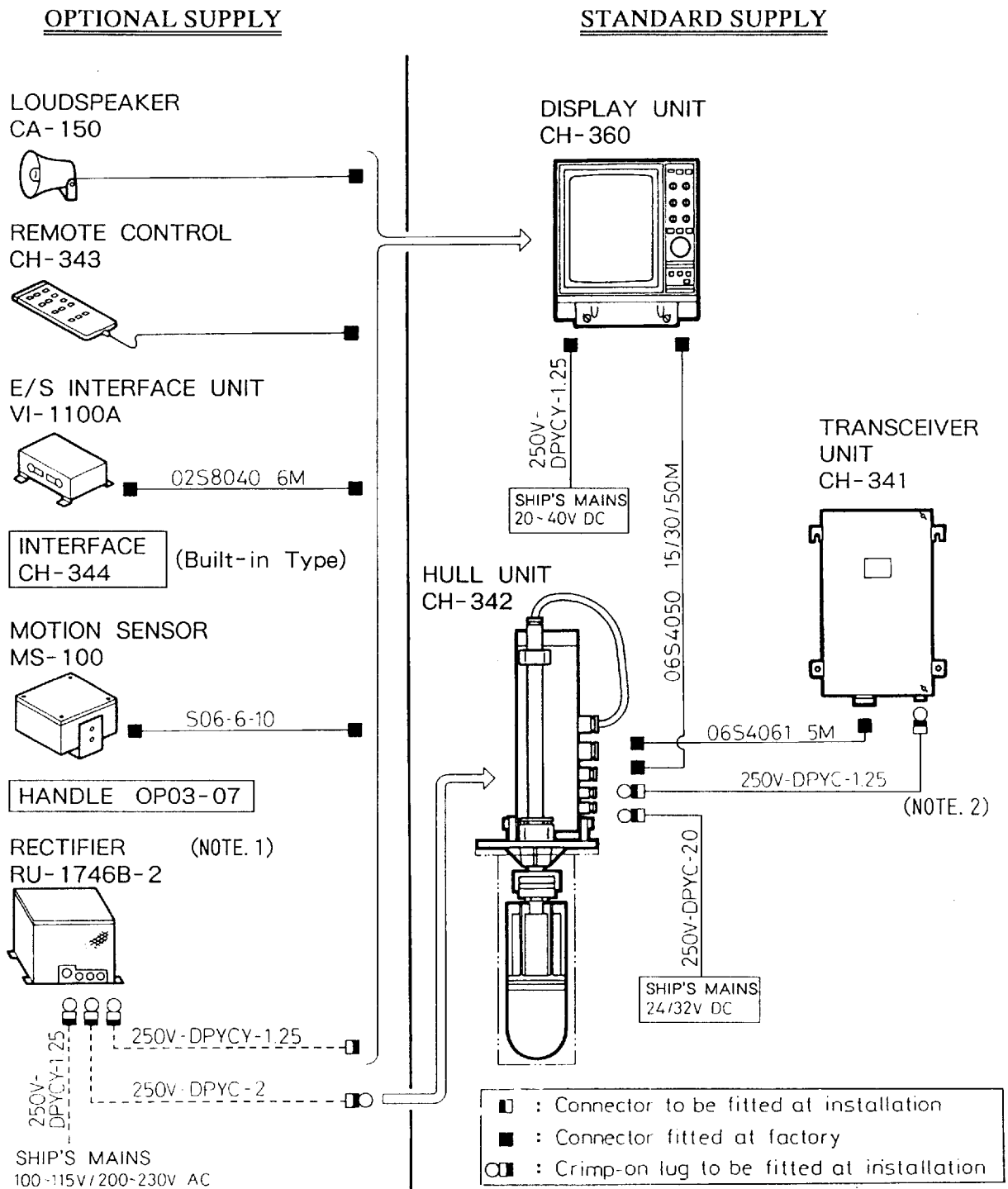







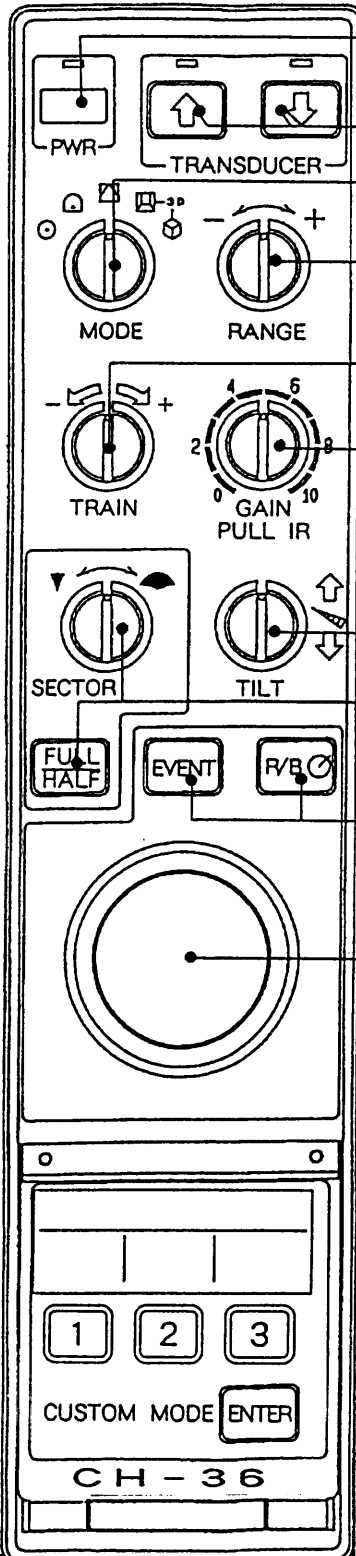

NOTES:

1. Two sets of rectifiers are necessary for AC ship's mains.
2. DC ship's mains only. For AC ship's mains, the power is supplied directly from the rectifier unit to the transceiver unit.

CHAPTER 1. CONTROLS AND FUNCTIONS

1-1. MAIN PANEL



FUNCTION	DESCRIPTION	For details see page—
PWR (ON/OFF)	switches on and off the entire system.	
TRANSDUCER (RAISE/LOWER)	controls the transducer. Each position functions as follows.  : Raises the transducer.  : Lowers the transducer.	
MODE	selects display mode;  Normal Sonar Mode or Normal Sonar Mode + E/S Combination*  Expanded Sonar Mode  Vertical Fan Mode or Vertical Fan Mode + E/S Combination*  3D Display* (front perspective view)  3D Display* (slant perspective view) *: <i>Optional supply.</i>	1-3
RANGE	selects the detecting (display) range. Turn clockwise to increase the detection range. The selected range appears in large characters, for a few seconds and remains at the upper right corner of the screen.	2-2, 3-2
TRAIN	determines the center bearing of the train sector. The selected bearing appears by a large white mark on the bearing scale. In the expanded sonar mode, it controls the direction to be off-centered (four directions). In the vertical fan mode, it determines the bearing of the vertical fan training.	3-3
GAIN/PULL IR	adjusts the receiver sensitivity. Turning the control clockwise increases the sensitivity. When changing the range and tilt settings, readjust the gain. For normal use, set it between "3" and "5". When interference can be seen on the screen, pull out the GAIN control to reduce or eliminate it.	2-6, 2-7 3-5
TILT	controls the tilt angle between +5° and -90°. The setting angle is set in 1-degree steps and appears at the upper right corner of the screen. (in the sonar mode) In the vertical fan mode, it determines the sector center of vertical scanning.	2-3 to 2-5 3-4
SECTOR	selects the width of the transducer training sector among six positions (45°, 90°, 135°, 180°, 225°, and 360°). The direction of training can be made in both directions except at the 360° setting. (in the sonar mode) In the vertical fan mode, the sector widths are 36°, 60°, 96°, 120°, 156° and 180°. FULL/HALF key switches the training sector or sector width between full circle and half circle by one key stroke.	2-2, 2-9
FULL/HALF		
TRACKBALL	moves the trackball marker (+). The trackball mark data, that is, slant range, horizontal range, depth and bearing to the mark, are always indicated on the screen. Additionally, this control positions the R/B (Range/Bearing) marker and sets the event marker with the R/B and the EVENT keys. R/B key also silences the alarm when it is released.	2-8, 3-5
R/B EVENT		
CUSTOM MODE	provides user-defined sonar settings by one key operation.	4-1
DEMAG	Demagnetize the display for clearing irregular picture color.	

1-2. SUB-PANEL

Sub-panel 1

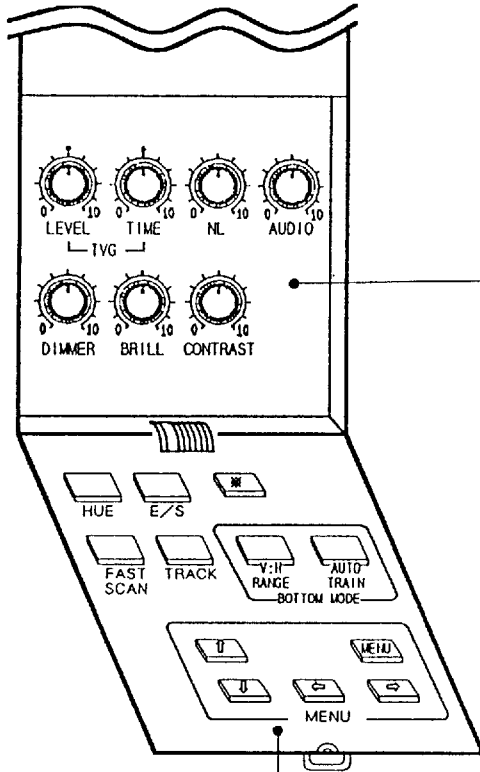





Sub-panel 2



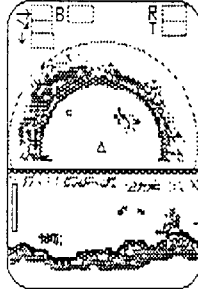

FUNC-TION	DESCRIPTION	For details see page...
TVG	LEVEL controls the receiver sensitivity to eliminate surface noise, which may mask shallow targets. TIME determines the TVG effective range.	3-1, 3-2.
NL	rejects noise which appears on the screen in light blue or blue. A setting between "2" and "4" will suffice in most case.	3-4.
AUDIO	adjusts the volume of the external loudspeaker, which monitors target echoes.	3-5.
DIMMER	adjusts panel illumination.	
BRILL	adjusts brightness of the screen.	

FUNC-TION	DESCRIPTION	For details see page...
HUE	changes the background color of the display in the sequence of deep blue, blue, black.	
E/S	turns on and off the E/S combination display. (Optional devices required.)	
*	spare key (not used).	
FAST SCAN	changes the sector steps(45°/6° in sonar mode and 6°/3° in vertical fan mode).	
TRACK	turns on and off the course line plotting. (Navigation equipment required.)	
V:H RANGE	changes the horizontal range scale in the vertical fan mode.	
AUTO TRAIN	changes the auto and manual train in the vertical fan mode.	
MENU	calls the menu screen of the mode in use. Use arrow keys to change settings to obtain best echoes.	1-8.

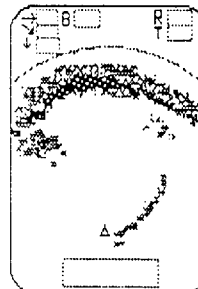
1-3. PRESENTATION MODE

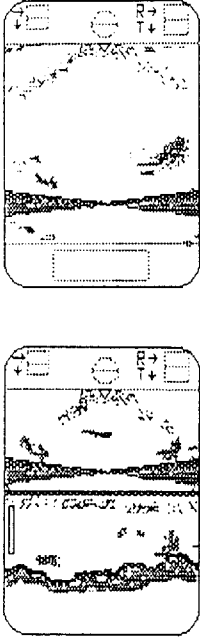
Five presentation modes are available: Normal sonar or Normal sonar + E/S combination, Expanded sonar, Vertical fan mode or Vertical fan mode + E/S combination and 3D display mode (front and slant perspective view).

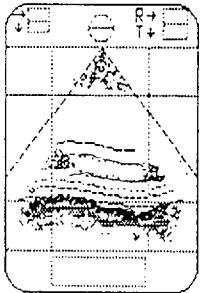
Mode	Presentation	
		<p>Normal sonar mode</p> <p>Normal full circle picture appears on entire screen.</p>
		<p>Normal sonar + E/S combination*</p> <p>Normal circle picture appears at the upper portion of the screen and the echo sounder picture on the lower portion.</p>
		<p>Expanded sonar mode</p> <p>Zoomed picture appears on the entire screen. The echo size on the screen is expanded 1.5 times.</p>

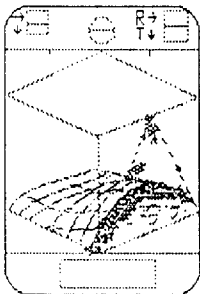
		<p>Vertical fan mode</p> <p>A vertical section of underwater conditions (half-circle area) appears on the entire screen.</p> <p>Vertical fan mode + E/S combination*</p> <p>A vertical section of underwater conditions (half-circle area) appears on the upper half and echo sounder picture on the lower half.</p>
		<p>3D display (front perspective view)**</p> <p>The vertical contour line appears historically (time or distance). Only the latest echo is painted, like the vertical mode presentation.</p>
		<p>3D display (slant perspective view)**</p> <p>Display contents are same as front perspective mode except the view point.</p>

■ **NOTE:**
Asterisk-marked modes are optionally available. See your dealer or agent for further information.

CHAPTER 2. SONAR MODE OPERATION

2-1. PROCEDURE

Typical operating procedure of the CH-34 is shown below.



Observe maximum allowable ship's speed of 18 knots during operation and 15 knots while raising/lowering transducer.

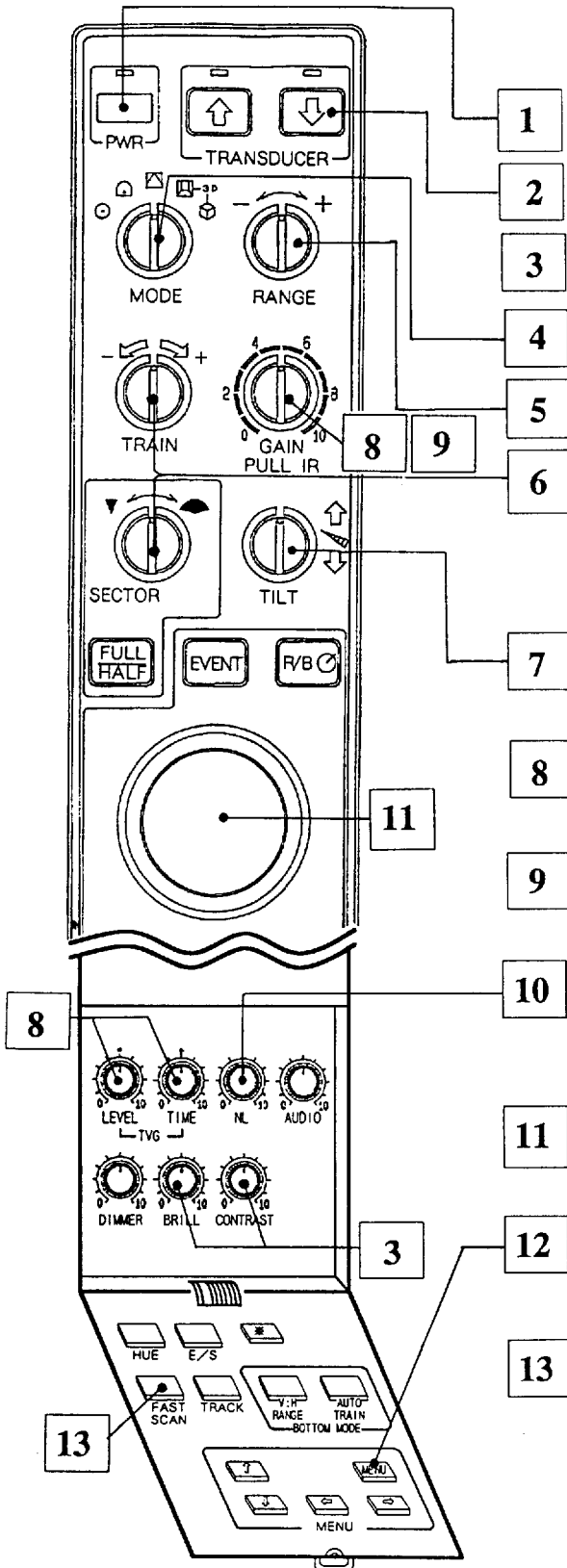

1 Turn on the display unit.

2 Lower the transducer.

3 Adjust the contrast and brilliance of the CRT.

4 Set the MODE knob to or position.

5 Select the range desired with the RANGE switch.

6 Select the automatic training area and center position with the SECTOR and TRAIN switches. The FULL/HALF key provides a quick change of the area (225° \longleftrightarrow 360°).

7 Adjust the tilt angle with the TILT control knob. See pages 2-3 through 2-5 for details.

8 Adjust the GAIN and TVG controls. [Gain: 3 - 5, TVG(level & time): 3-5]

9 If interference is on the screen, pull out the GAIN (IR) control.

10 Adjust the NL control if a large number of small blue dots appears on the screen. Normally set it between "2" and "4."

11 With the trackball marker, measure the distance to a fish school or the seabed.

12 Reduce the output power if necessary. Normally, set it for maximum position (C).

13 Turn off "FAST SCAN" mode if longer detection is required.

Range Selection

The RANGE control selects the detection (display) range. Select the range according to either the fish species being searched or the depth desired. Normally it is set so that the bottom is traced at the lower part of the screen (like an echo sounder).

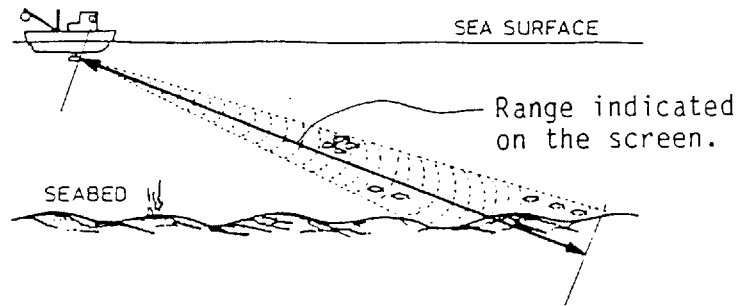

	Freq.	- RANGE +							
Range (m)	60kHz	50	100	150	-----	600	800	1200	1600
	162kHz	50	100	150	-----	450	500	600	800

■ **NOTE:**

- 1) The unit of measurement can be changed through the system menu. See page AP-2.
- 2) Maximum detection range differs with each frequency.

SECTOR Selection

Sector means the width of the transducer training. The sector knob selects the training (display) area among six positions.

Mode	Transducer Training Sector(display area)
Sonar mode	45°, 90°, 135°, 180°, 225° and 360°

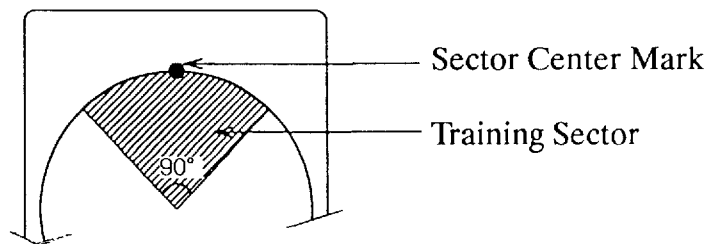

■ **NOTE:**

- 1) In the full circle mode (360°), the direction of training is clockwise only.
- 2) Sectors appearing in shading in the table above are selected by the FULL/HALF key.

Setting the Tilt Angle

Finding the proper tilt angle is of utmost importance when searching for fish. When selecting a tilt angle, keep the following points in mind.

Seabed Echo vs Tilt Angle

Case 1: Tilt Angle 30 to 40 degrees

A wide tilt angle will display the entire seabed since it is captured by the full width of the beam.

Case 2: Tilt Angle 10 to 20 degrees

A narrow tilt angle will display only half the seabed since it is captured by only the lower half of the beam.

Case 3: Tilt Angle 0 to 10 degrees

An exceptionally narrow tilt angle may or may not capture the seabed since the returning echo is weak.

Example of How to Discriminate Fish Echoes from the Seabed

The figure which follows illustrates how two fish schools (a) and (b) appears on screen using three different tilt angles.

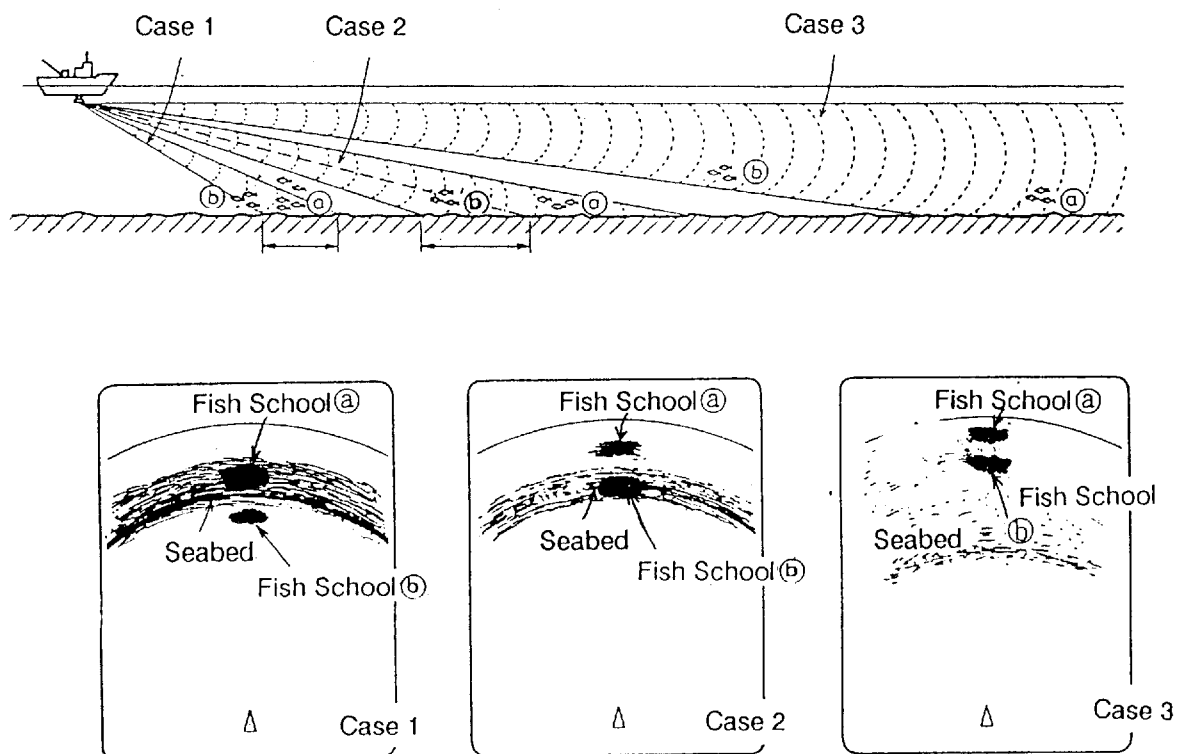

Points to Consider

- As a general rule of thumb, a vertically distributed fish school is a better sonar target than the seabed, since it reflects the transmitted pulse back toward to the source.
- In case 3, both fish schools (a) and (b) are presented. Generally speaking, however, midwater fish schools tend to be larger than bottom fish schools and they are often displayed near the seabed on the sonar screen.
- Detection of bottom fish is difficult if they are not distributed vertically.

Tilt Angle for Surface Fish

Sound emitted from the sonar transducer forms an oval-shaped beam with a width of approximately 13 degrees* in the vertical direction (vertical beam width). The tilt angle is indicated by the angle between the center line of the beam and the horizontal plane. Then, if the tilt angle is set to 0 degrees, the center line is parallel with the sea surface and one half of the emitted sound goes upward toward the sea surface. (*: for 60kHz transducer)

This causes one half of the emitted sound to be reflected back toward the transducer and displayed on the screen as sea surface reflections. When the sea is calm, since the sound is reflected just like a light hitting a mirror at a narrow incident angle, it propagates away and the sea surface reflections become negligible.

However if the sea is not calm enough, they will become dominant and will interfere with observation of wanted echoes. To minimize these sea surface reflections and to search surface fish schools effectively, the tilt angle is usually set between for and six degrees so that the upper portion of the beam becomes almost parallel with the sea surface. When the sea is rough, it is often set for a little larger angle.

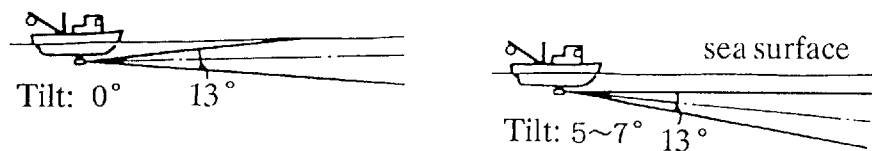

Suitable Tilt Angle

The figure on the next page illustrates the relationship among tilt angle, depth and detection range. Refer to it to find out the suitable tilt angle for a given depth/detection range.

TILT SETTING

Frequency : 60kHz
 Vertical Beamwidth : 13°

RANGE m

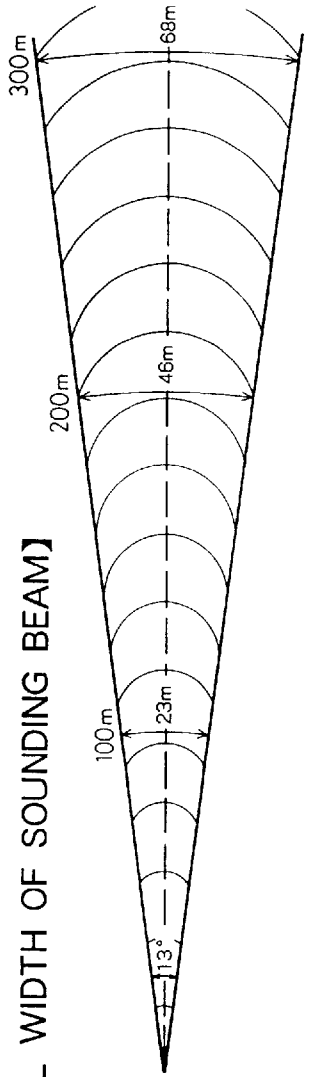
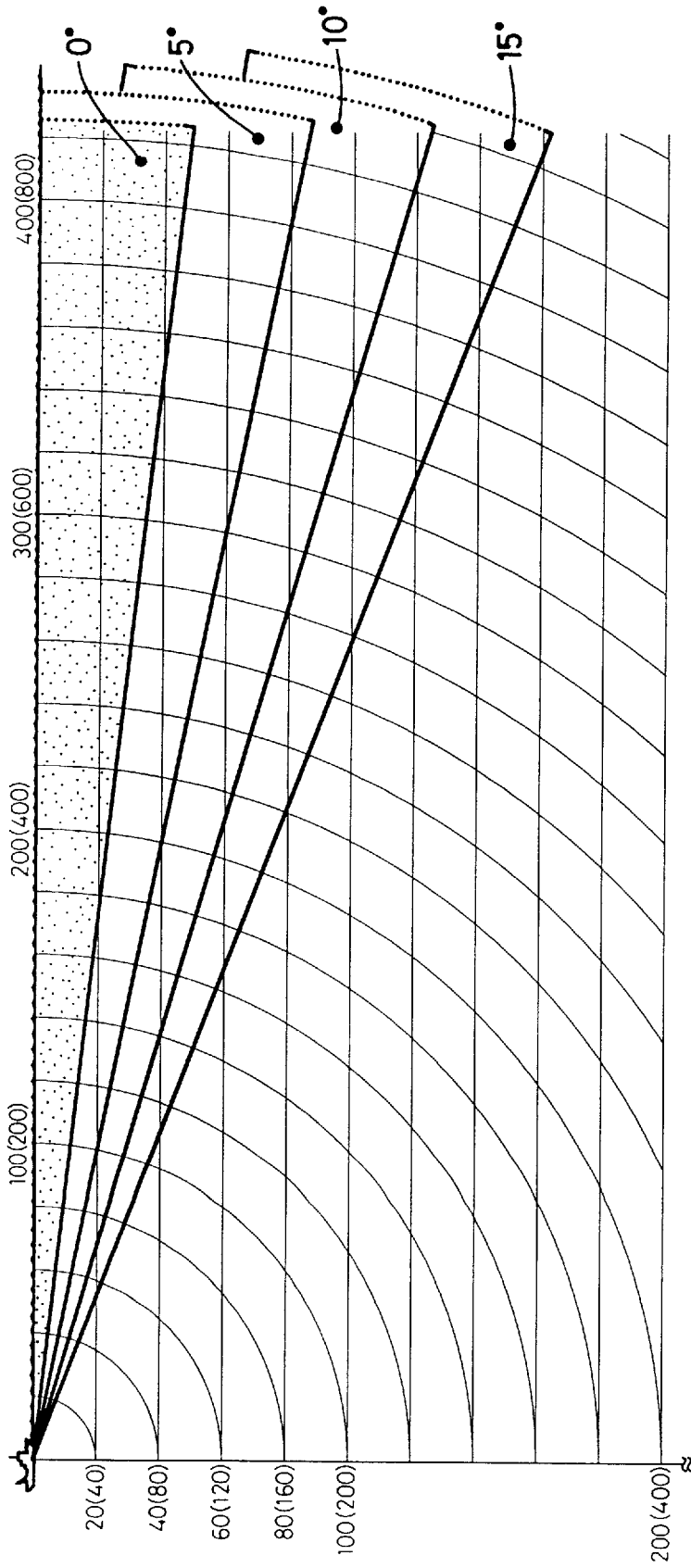

【VERTICAL WIDTH OF SOUNDING BEAM】

Gain Setting

Most equipment malfunctioning claims result from improper setting of switches and controls. For example, fish, fish habitat or outcrop can not be readily detected by merely increasing the gain. Initially set the gain between "3" and "5". Then, fine tune depending on the fishing ground, frequency used, etc.

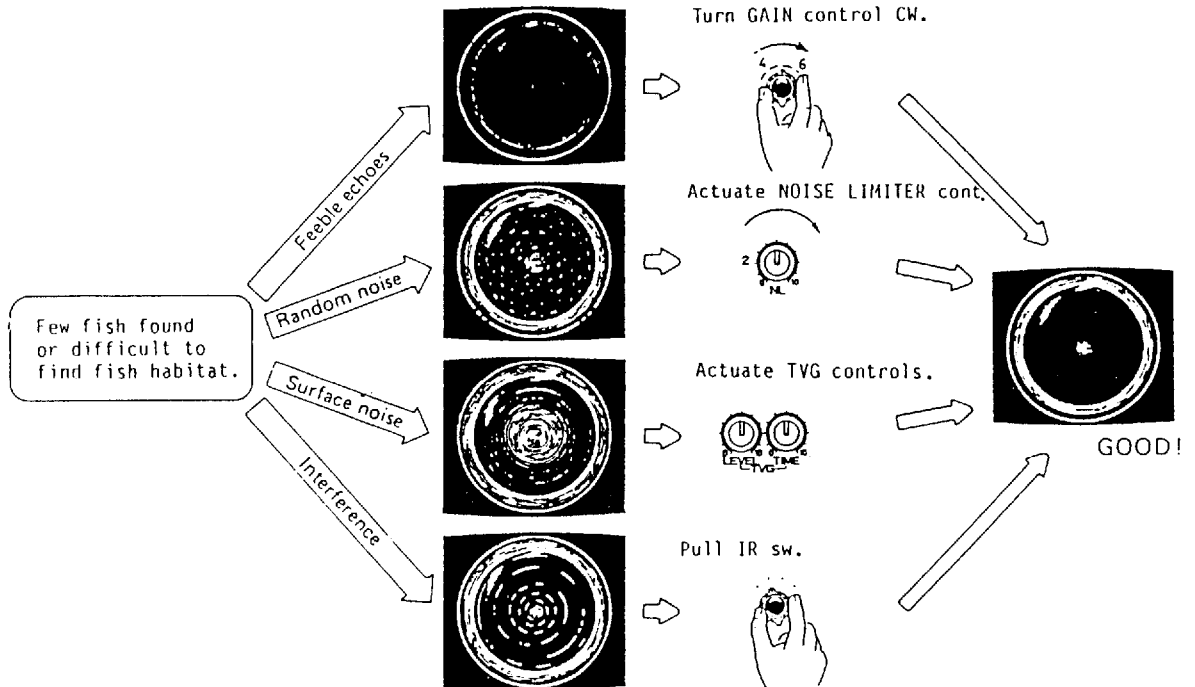

Rejecting Sonar Interference and Noise

While observing the sonar picture, you may encounter occasional or intermittent noise and interference as shown below. These are mostly caused by onboard electronic equipment, engine, propeller noise, or electrical noise from other sonars being operated nearby.

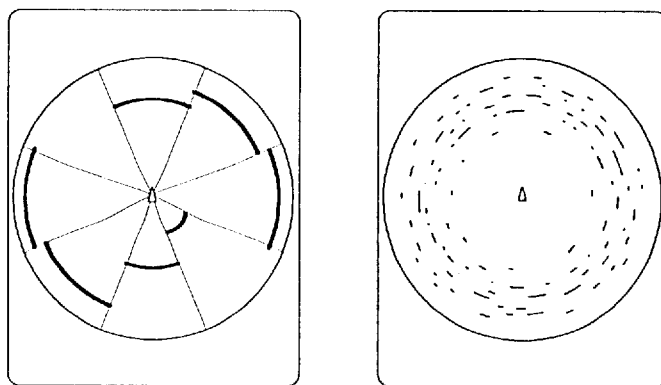

Identifying Noise Source

To eliminate noise effectively, you should first identify the source.
 * Operate all onboard equipment one by one while observing the

picture.

* Run the boat at various speeds to check if the noise is speed dependent.

If neither of the above affects the picture, adjust the **IR** (Interference Rejector) and **NL** (Noise Limiter) controls as follows.

Rejecting Noise with IR Control

This control is similar to the interference rejector on echo sounders and radars. It is effective for rejecting random noise and sea surface reflections in rough sea conditions. Set the **IR** control between "1" and "3" so that noise is just eliminated. Do not use an unnecessarily high setting since it may also reject small wanted echoes.

Rejecting Noise with NL Control

Weak, unwanted reflections, colored light blue or green, appear when water is contaminated, plankton layers exist or due to ship's noise. These echoes gradually become bluish as the **NL** control is turned clockwise. Usually a setting from "3" to "4" provides sufficient reduction.

Rejecting Interference with TX Rate

When other sonars are operating nearby at the same transmission interval as that of own ship's sonar, interference caused by other sonars appears. To reduce the interference, reduce the TX rate setting on the sonar menu screen.

■ **NOTE:**

When the sonar is used in shallow water with the range set between 100m and 200m and the TX rate at "10", seabed reflections caused by the transmission which is the last but one appear on near range on screen. Reduce the TX rate to "7" or "8" to reject them.

Detecting Fish Schools Aurally

Occasionally you will be preoccupied with other tasks and unable to concentrate on watching the sonar picture. In such cases it would be a good choice to use the audio function. This function enables you to monitor echoes from fish schools and seabed through the external speaker.

After you become accustomed to utilizing the audio function, you should be able to detect a fish school from a range longer than you can detect it on the screen. In addition you may judge whether the fish school is approaching or going away; the tone becomes higher when the fish is approaching and lower when going away.

**Using R/B Mark
and Event Mark
(trackball operation)**

The trackball has two functions basically.

- (1) To obtain the data (slant & horizontal range depth and bearing) from own ship to the specified position on the screen.
- (2) Combined with the R/B and EVENT keys, the R/B and EVENT mark is switched on and off.

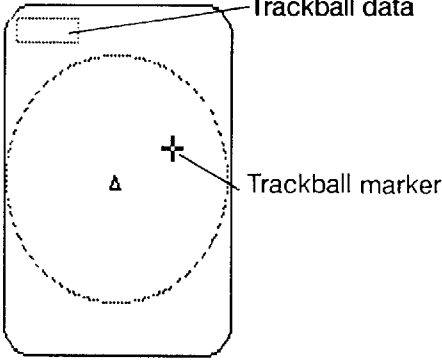
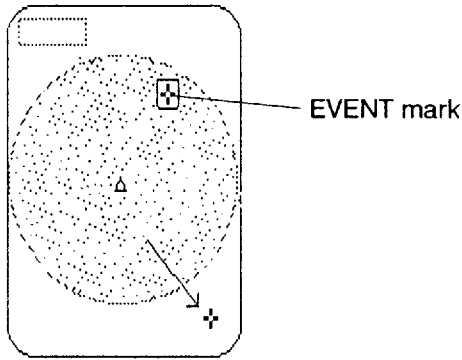
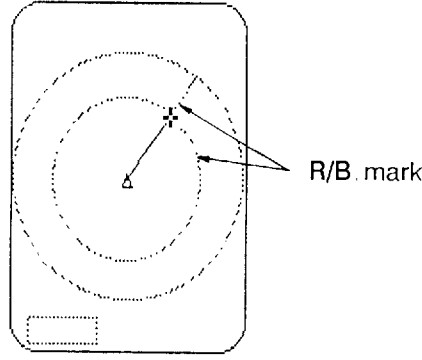
Function	Procedures/Purpose
Trackball Data	 <ol style="list-style-type: none"> 1) Position the trackball marker on the desired location. 2) Read the trackball data displayed at the upper left corner of the screen.
EVENT mark	 <ol style="list-style-type: none"> 1) Position the trackball marker on the desired location. 2) Press the EVENT key. The EVENT mark appears. 3) To erase the mark, place the trackball mark outside the echo display area and press the EVENT key. <p>Note: CH-34 holds one EVENT mark.</p>
R/B mark	 <ol style="list-style-type: none"> 1) Position the trackball marker on the desired location.

	<p>2) Press the R/B key. The range and bearing markers appear and their data appears at the bottom left-hand side of the screen.</p> <p>3) To erase the Marker;</p> <p>Place the marker near the own ship's position or outside the echo display area and press the R/B switch.</p>
--	---

Selecting Training Sector Quickly

Normally the training sector is selected by the SECTOR knob. To the training sector more quickly, however, use the FULL/HALF key. This key allows the switching between full circle and half circle training sector by one key stroke.

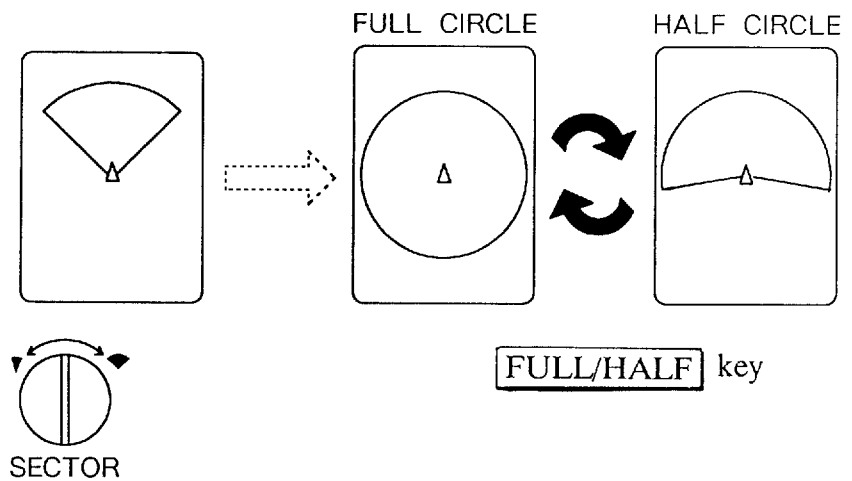

2-2. FINE TUNING THE PICTURE

Suppressing Seabed and Sea Surface Reflections in Shallow Fishing Grounds

In shallow fishing grounds, excessive sea surface and seabed reflections often interfere with wanted fish echoes and they can not be eliminated sufficiently with the aforementioned TVG controls. In such cases, try to reduce the output power from C to B or A on the menu screen, without turning down the gain. The picture becomes more clearer when output power is reduced rather than when the gain is decreased as illustrated below.

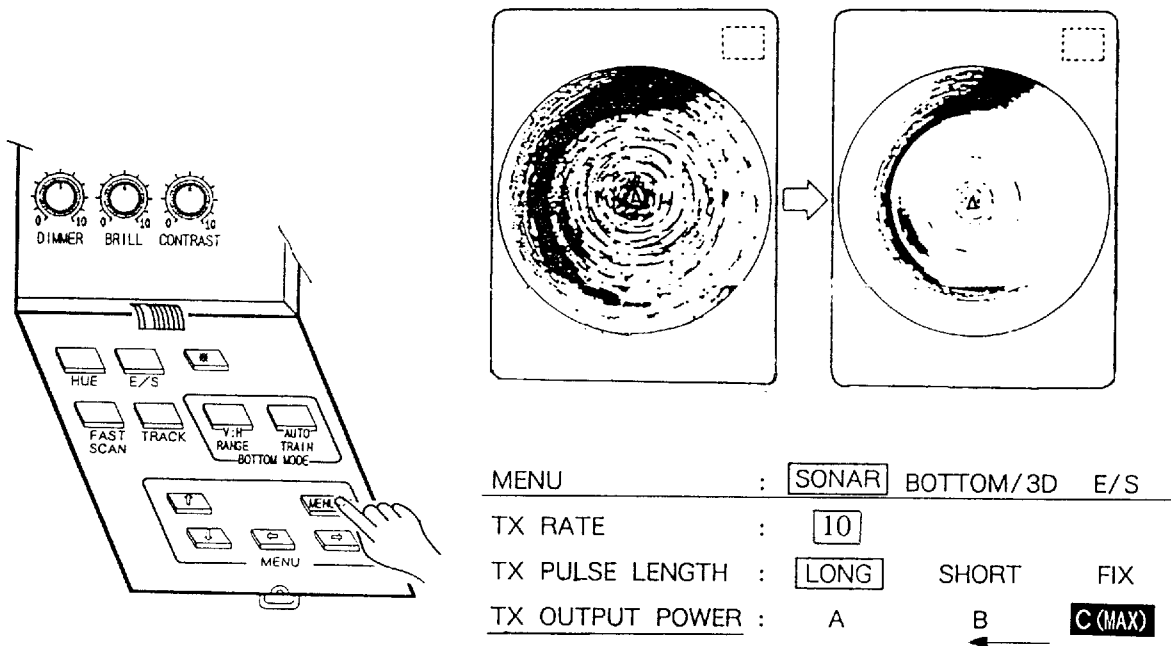

Suppressing Seabed Tail

As described earlier, fish schools near the seabed are sometimes difficult to detect because you have to discriminate fish echoes in the seabed reflections. Select the short TX pulse length to decrease the tail of seabed reflection to make it easier to discriminate bottom fish.

Displaying Surface Fish Clearly (applying proper TVG)

Echoes from targets (such as a seabed or a fish) return to the transducer in order of the distance to them, and when their intensities are compared at the transducer face, those from nearer targets are generally stronger when their reflecting properties are nearly equal. The sonar operator will be quite inconvenienced if these echoes are directly displayed on the screen, since he won't be able to judge the actual size of the target from the size of echoes displayed on the screen. To overcome this inconvenience, use the TVG function. It compensates for propagation loss of sound in water; amplification of echoes on short range is suppressed and gradually increased as range increases so that similar targets are displayed in similar intensities irrespective of the ranges to them.

In the CH-34, the TVG LEVEL and TIME controls compensate for propagation loss. The effective distance is up to 1000m approximately.

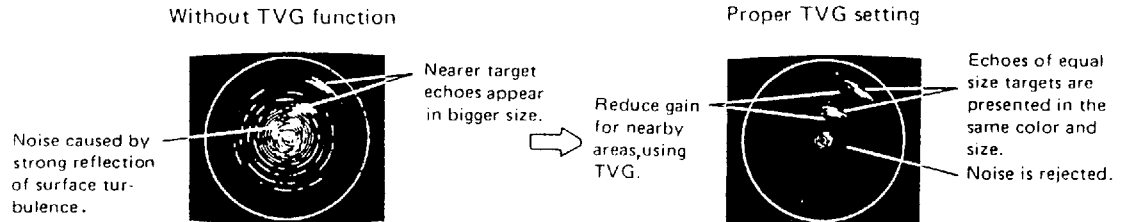

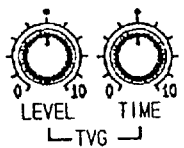
	Position	TVG Range
	0	0m
	2	60m
	3	130m
	5	300m
	10	1000m

The TVG also functions to suppress unwanted echoes and noise which appear in a certain range area on the screen as shown in the figure above. To obtain the proper TVG setting, follow the procedure below.

(Procedure)

1. Set TVG time between the "3" and "5" (approx. 130-300m). This is the standard setting and you can maintain this setting in most cases.
2. When sea surface reflections or plankton layers disturb the picture, set the TVG level knob around "5" to eliminate them.
3. Locate a fish school on a long range setting which is approaching your vessel. Adjust the tilt to keep the fish school in the center of the sonar beam. Check that the fish echo appears in the same color while it approaches. If the color changes suddenly to weaker colors as the fish echo nears area, the TVG is improperly set. Adjust the TVG level to correct it. If sea surface reflections and noise remain, try to remove them with the interference rejector (IR) and noise limiter (NL) controls as described on page 2-7.

Relocating Fish School for Easy Observation

When a fish school is near the edge of the screen and inconvenient for observation, use the "  " expanded sonar mode and turn the TRAIN knob (off-center function) to relocate the fish school close to the screen center.

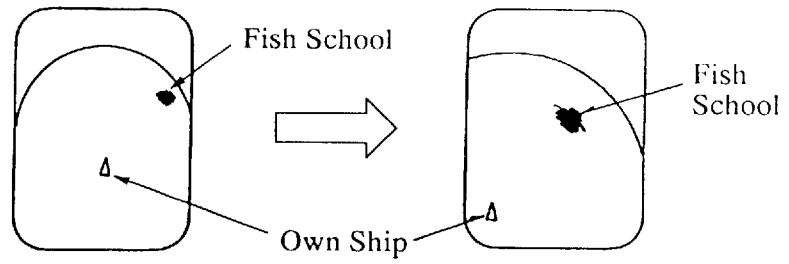

Finding Fish School Center

When you want to find the center depth of a fish school, change the TILT angle and observe the presentation.

Procedure

1. Select a narrow sector range (45 degrees) and capture the target echoes.
2. Adjust the TILT angle slowly and observe the change of the presentation color.
3. The echo presented in the strongest color is the center of the fish school.

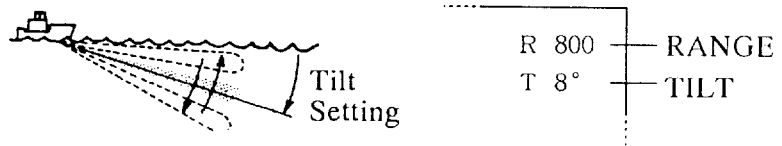

2-3. MENU SCREEN

- Operating Procedure**
- (1) Press the MENU key on the Sub-panel 2.
 - (2) Select the sonar menu.
 - (3) Select item with the horizontal arrow key and set parameters with the vertical arrow key. The selected item is highlighted and the current setting is circumscribed in white.
 - (4) To turn off the menu, press the menu key again.

Sonar Menu

MENU	:	<input type="text" value="SONAR"/>	BOTTOM/3D	E/S
TX RATE	:	<input type="text" value="10"/>		
TX PULSE LENGTH	:	<input type="text" value="LONG"/>	SHORT	FIX
TX OUTPUT POWER	:	A	B	<input type="text" value="C (MAX)"/>
TX EXT SYNC	:	OFF	<input type="text" value="ON"/>	
STABILIZER	:	OFF	<input type="text" value="ON"/>	
COLOR	:	<input type="text" value="16"/>	8	
RES. COLOR	:	<input type="text" value="LOG"/>	LINEAR	SQUARE
EXIT	:	PRESS MENU KEY		

Contents of Sonar Menu

Menu Item	Meaning
TX RATE	Selects transmission repetition rate in ten steps; "1" is for the longest interval and "10" for the shortest. Set to "10" for normal use.
TX PULSE LENGTH	Selects TX pulselength among "LONG", "SHORT" or "FIXED". The pulselength is adjusted automatically according to the range setting in "LONG" or "SHORT" position. Set to "LONG" for normal use.
TX OUTPUT POWER	Adjusts output power; "A" is for minimum power and "C," maximum. Set to "C" for normal use, and use a low power when sea surface reflection or seabed echo obscures fish schools.
TX EXT.SYNC	If two or more echo sounders or sonars are operated simultaneously, mutual interference may result due to asynchronous keying pulse output. This menu turns keying pulse synchronization on and off.
STABILIZER	select "ON" when the Motion Sensor MS-100 is connected.
COLOR	selects 16- or 8-color presentation.

RES. COLOR	This menu sets the echo presentation characteristics. LOG enhances weak echo and is normally used. LINEAR downplays the weak echoes comparing with LOG. It is effective to suppress the plankton layer. SQUARE enhances the strong echoes comparing with LINEAR resulting in clear and easy-reading picture.
------------	---

■ **NOTE:**

The items appearing in shading in the tables require optional equipment. Consult with your agent or dealer for further information.

2-4. INTERPRETING THE DISPLAY

This section provides the information necessary for interpreting the display.

How the Picture is Painted.

The wide sounding beam is emitted from the soundome at a certain tilt angle (see hatched area in the figure below). The information (target echoes) obtained by this beam is displayed in 45-degree sector of the sonar screen. Thus, all directions around the boat are sounded in 8 times of transmissions.

■ **NOTE:**

When the "FAST SCAN" is switched off, the equipment operates in a narrow sounding beam. In this case, the echoes appear on a 6-degree sector in each transmission, so 60 times of transmissions are required to complete full 360° picture ($6^\circ \times 60 = 360^\circ$). This means that sounding speed reduces. However, since the transmission power is concentrated into the narrow sounding beam, a superior detecting range is obtained and also since the seabed contour is painted distinctly, bottom fish detection may become easier.

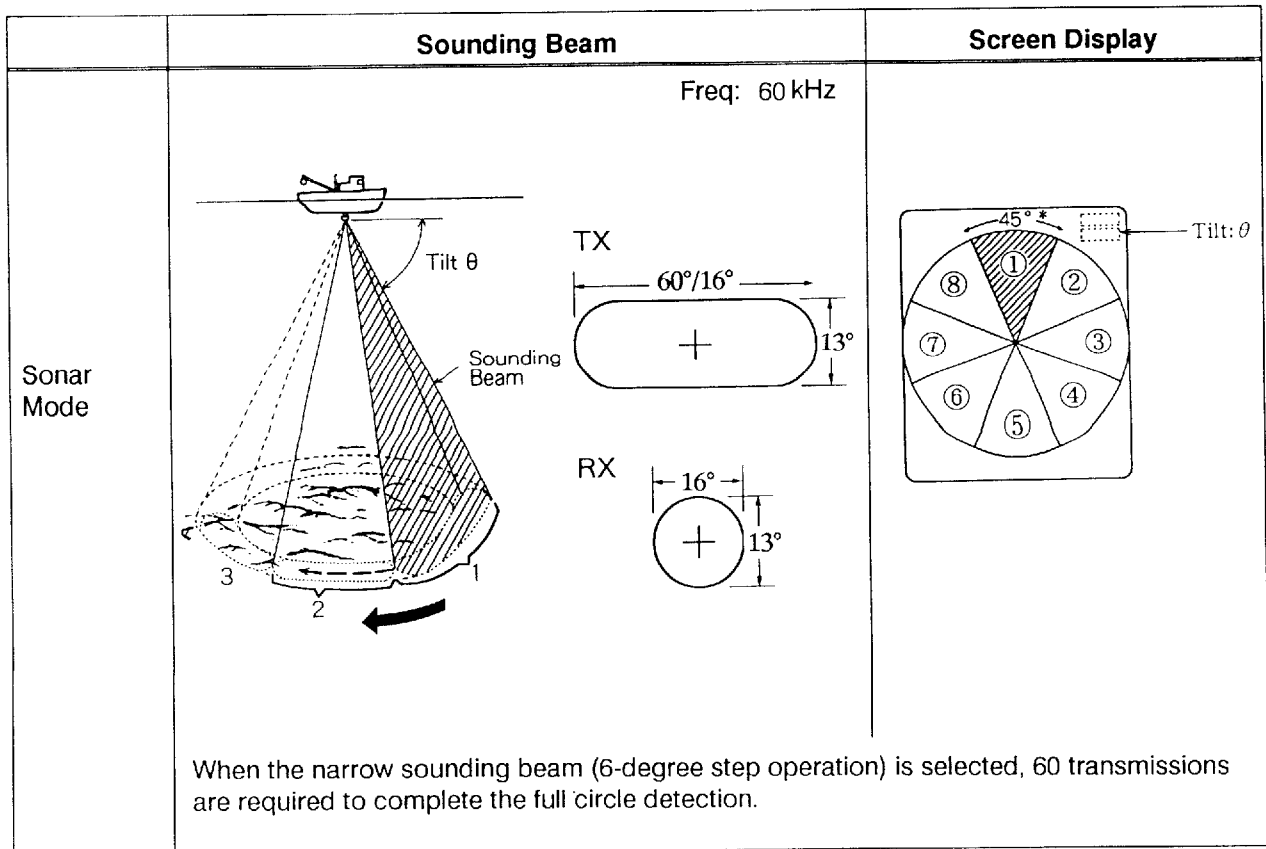

Seabed

When the tilt angle is set at 90 degrees with the sector center faced dead ahead, the pictures illustrated below appear on the screen. The seabed echo is represented on the screen as a thick line which realistically shows the bottom contour. When the tilt angle is decreased, the seabed trace becomes wider and weaker. By observing the seabed condition on the screen, the skipper can prevent the net from being damaged by a reef or a shipwreck.

(a) Flat Seabed

Tilt Angle: 10° - 15°

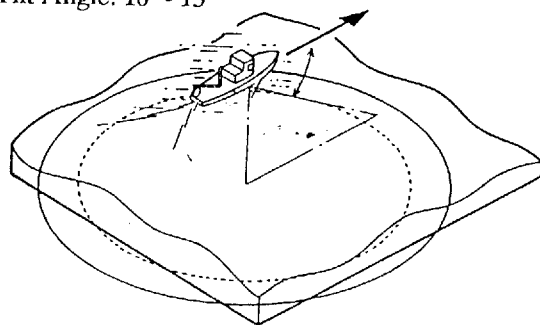

Seabed Echo

Narrow tilt angle; only half of vertical beam width captures the seabed.

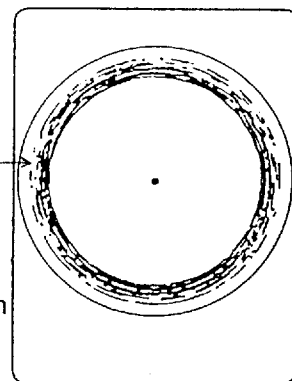

(b) Flat Seabed

Tilt Angle: 20° or more

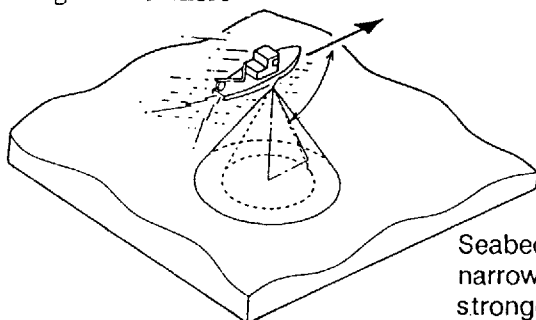

Seabed Echo

Seabed is displayed narrower and in a stronger echo colors compared to (a).

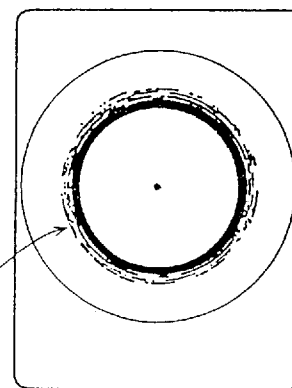

(c) Slanting Seabed

Tilt Angle: 20° or more

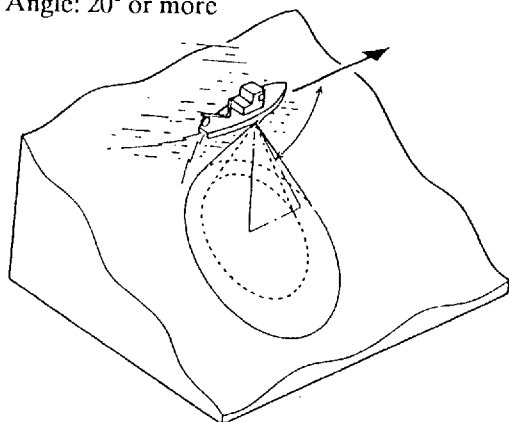

A shallow bottom is displayed in a strong echo color and with a short tail

Seabed Echo

The deeper seabed echo is displayed in a weak color and with a long tail.

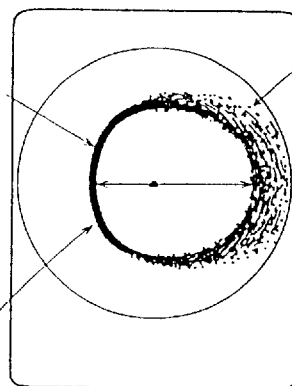

Fish School

A fish school appears as a mass of echoes on the screen. The color of the mass shows the density of fish schools on the sonar beam. To know the distribution and center point of a fish school, observe the fish school at several different tilt angles.

(a) Sea Surface Fish

Tilt Angle: $+5^{\circ} \sim 10^{\circ}$

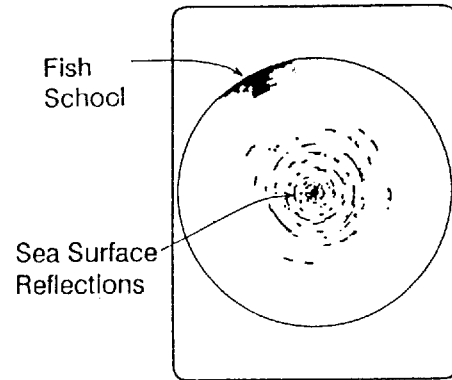
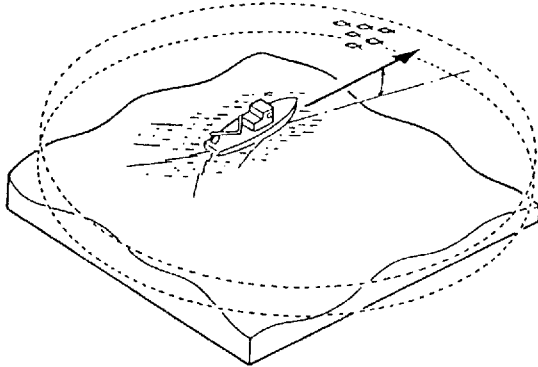

Because of the narrow tilt angle, seabed echo is not displayed. Sea surface reflections are present.

(b) Midwater, Bottom Fish

Fish echo appears before seabed echo

Tilt Angle: 30° or more

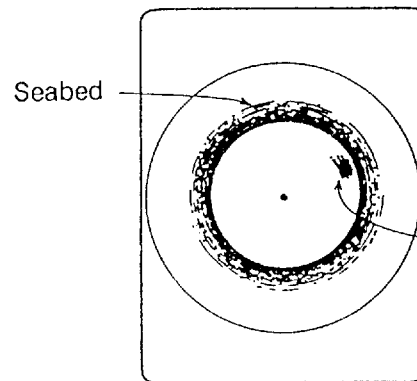
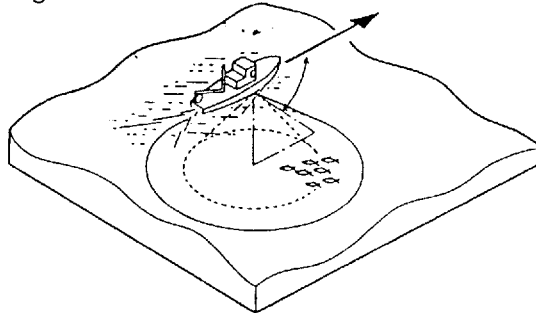

Fish School
Large midwater fish school is present.

Fish echo appears together with or after seabed echo

Tilt Angle: $0^{\circ} - 20^{\circ}$

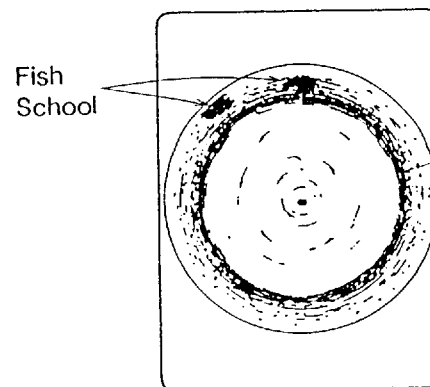
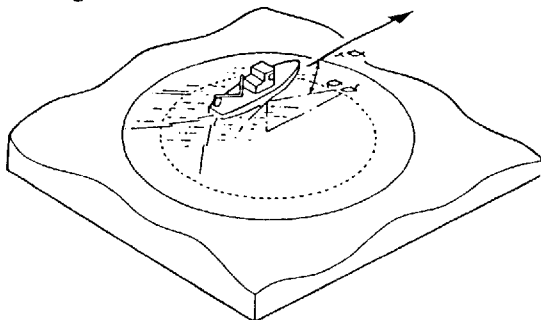

Seabed

Since the seabed is displayed in weak echo colors, longer range detection and detection of close to bottom fish school become possible.

Sea Surface Reflections

To reduce sea surface reflections, set the tilt angle to 5° or more so that the upper edge of the sonar beam does not hit sea surface, or adjust TVG controls. When the sonar is used with a narrow tilt angle, the sea surface reflections cover a large area (up to 300m to 400m) as illustrated below.

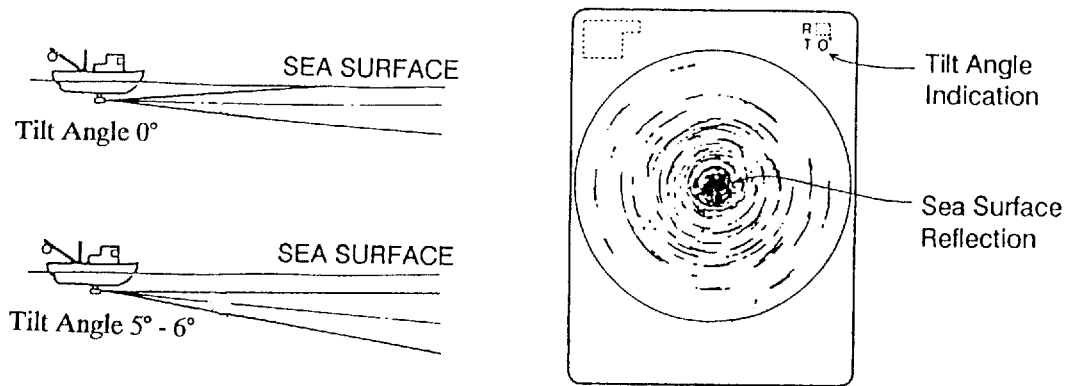

Wake

A wake produced by own ship or another ship can be a strong reflecting object when the sonar is used with a narrow tilt angle. As the wake appears on the screen as a thick continuous line, it can be easily distinguished from a fish school. On the other hand, the wake contains a lot of air bubbles which attenuate ultrasonic energy, making it often difficult to sound beyond the wake.

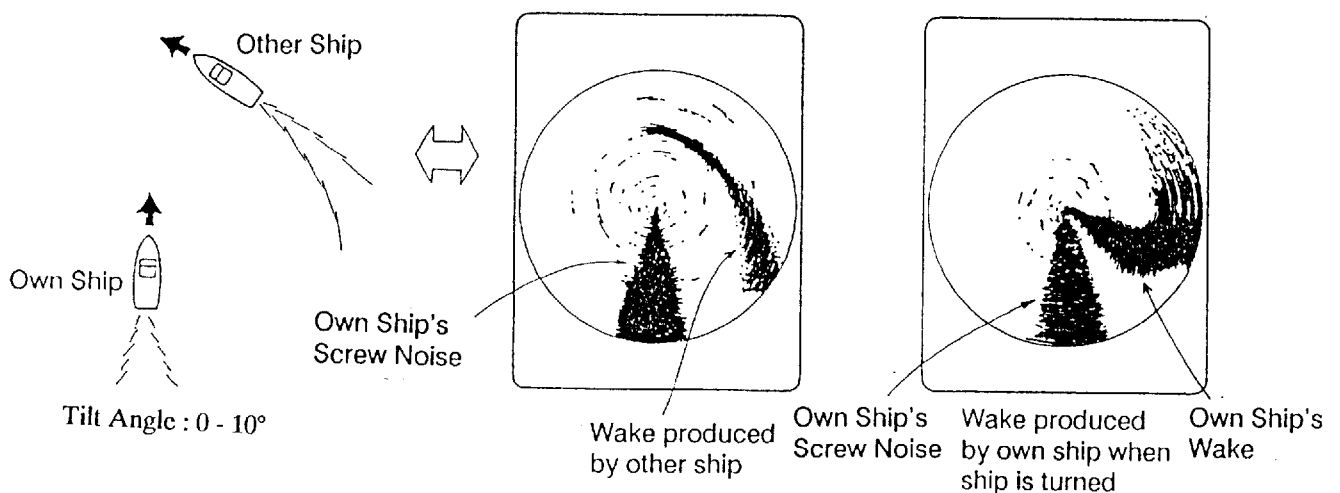

False Echo by Sidelobe

An ultrasonic wave is emitted only in the direction set by the TILT control, but, in practice, there are some emissions outside the main beam that are called "sidelobes". Energy of the sidelobe is fairly weak but when the sonar is used in comparatively shallow water with a hard and rocky bottom, strong target signals are detected by the sidelobe. These are represented on the screen as a false echo as shown below.

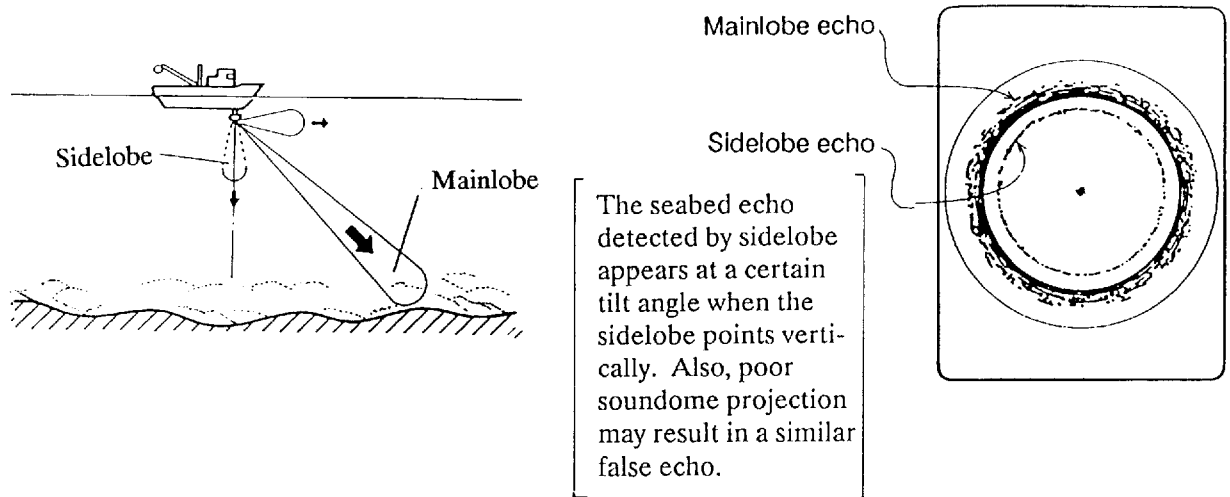

Noise and Interference

When the fishing ground is crowded with many fishing boats, the soar is subject to interference from ultrasonic equipment such as an echo sounder, sonar, etc. on board other boats as well as those on board own ship.

For instance, interference from the sonar operated on other boats will appear as shown in (A) in the figure below. This interference can be reduced by properly changing the TX rate. The noise from some marine life appears on the screen as in (B). This noise can be suppressed by the IR control.

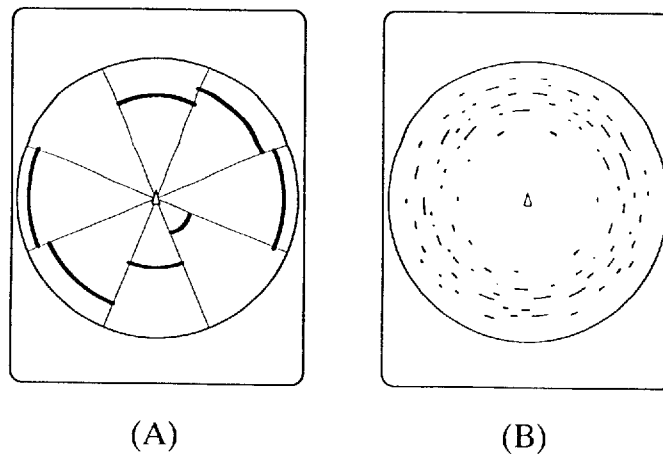

Noise and Interference

2-5. INDICATIONS ON THE SCREEN

Normal Sonar Display

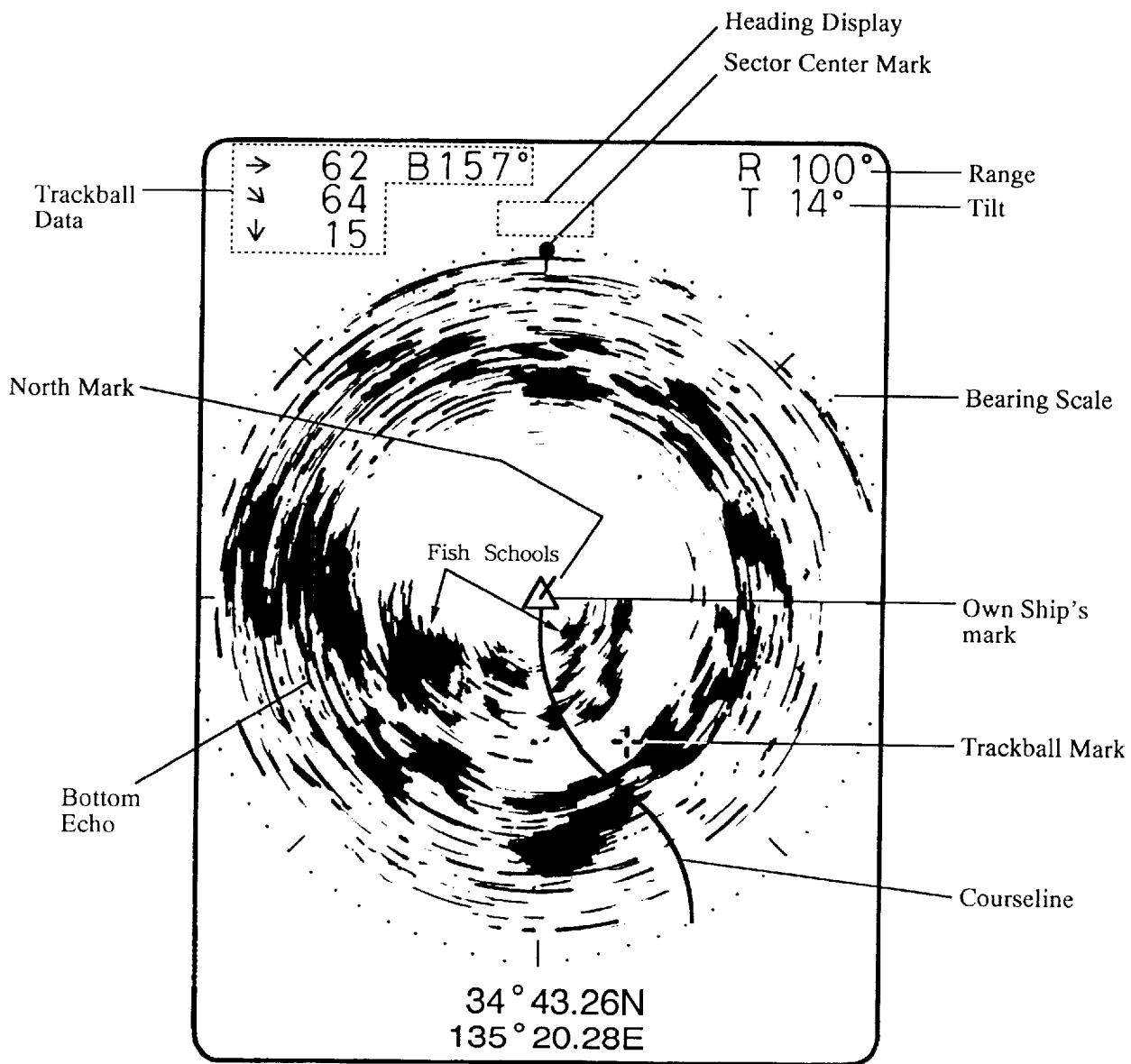

Expanded Sonar Display

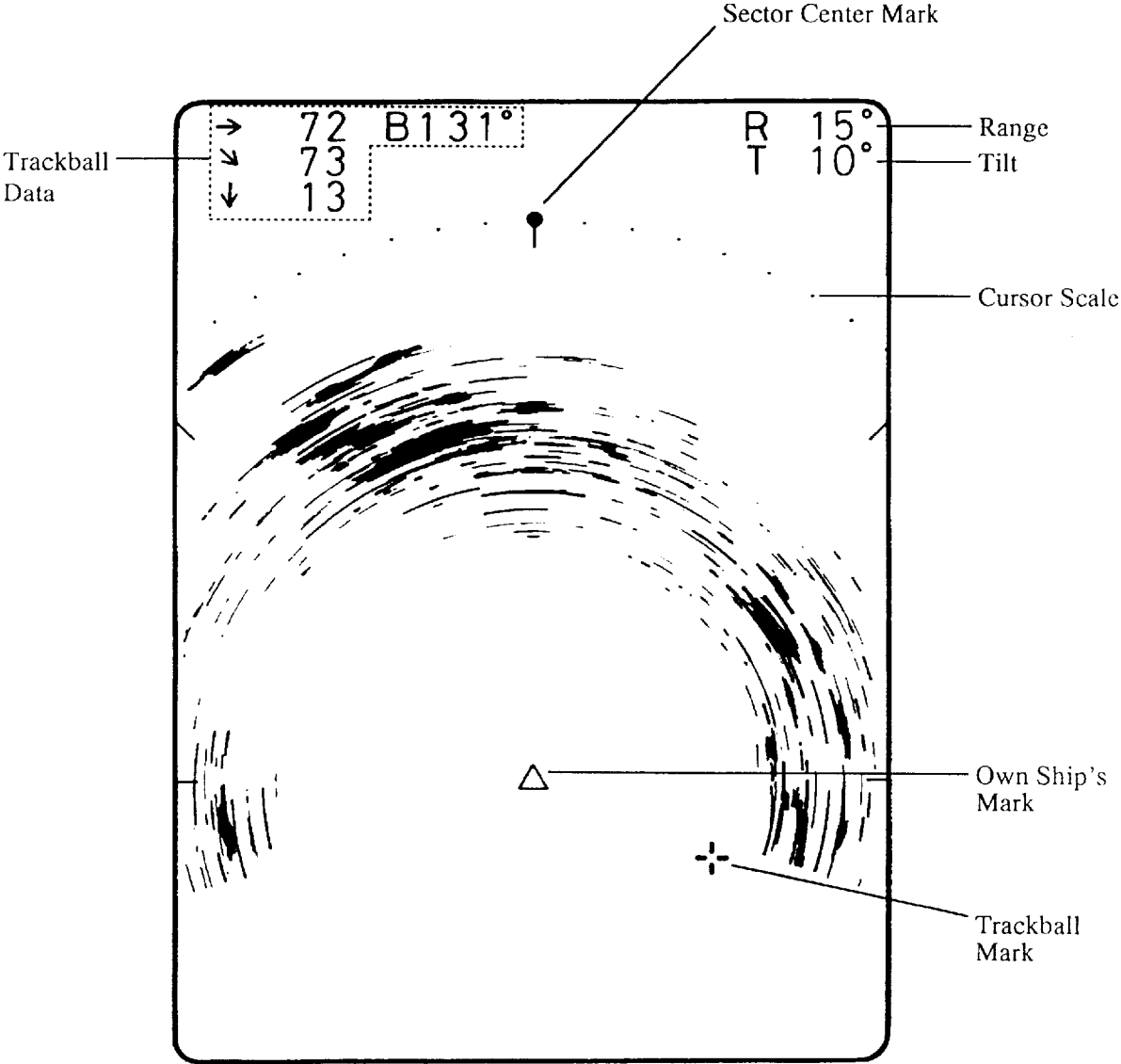

2-6. EXAMPLES OF APPLICATION

The following is a representative example of how the CH-36 is used.

Sonar (Horizontal) Mode

PURSE SEINING

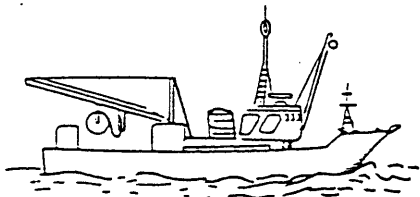

1 Power "ON".

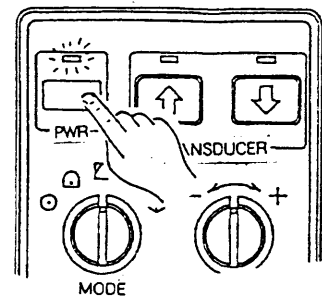

2 Lower soundome.

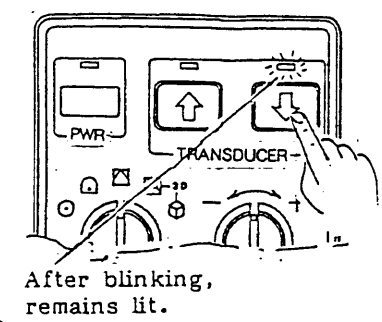

3 Search for fish school by RANGE and TILT sw. using.

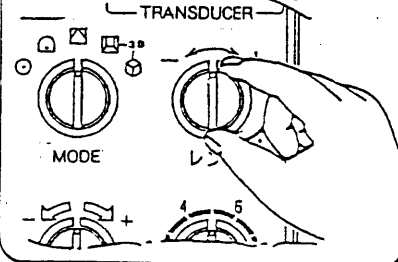

Here comes fish school!

4 Narrow the train area, and track fish school.

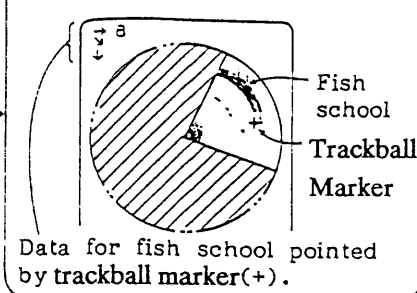

5 Change tilt angle for strongest fish school echo.

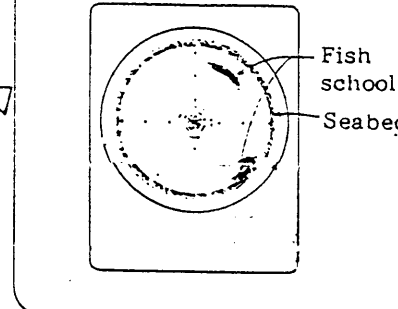

6 Monitor situation of both fish school and net.

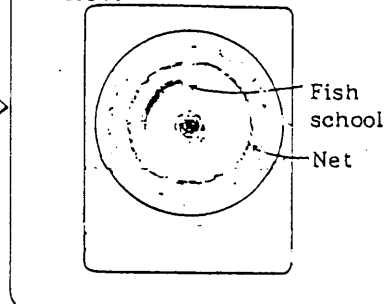

BOTTOM TRAWLING

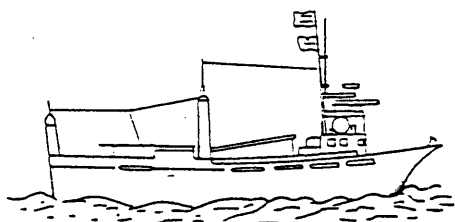

1 Power "ON".

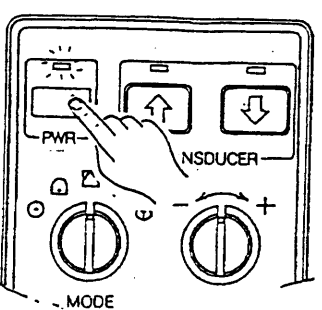

2 Lower soundome.

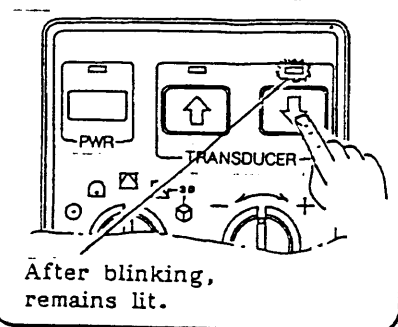

3 Observe seabed on the screen.

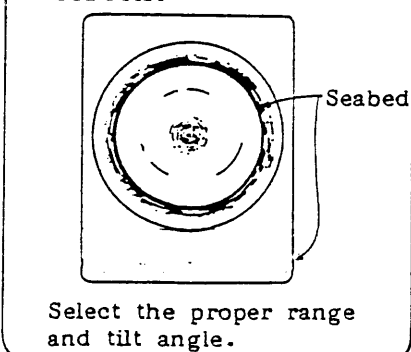

GAIN : 3~5"
NOISE LIMITER : 2~4"
TVG(level & time): 3~5"
TX POWER : C

Use these settings initially.
"Fine tune" as necessary.

4 Narrow the train area, and track fish school.

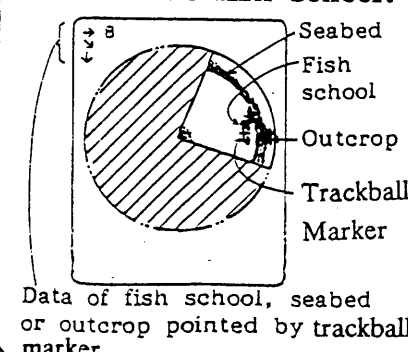

Here comes fish school!

5 Expand historical display and observe seabed.

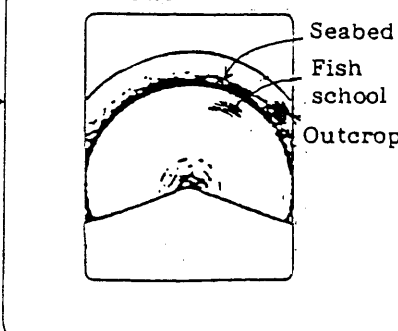

6 Change tilt angle, and tow net.

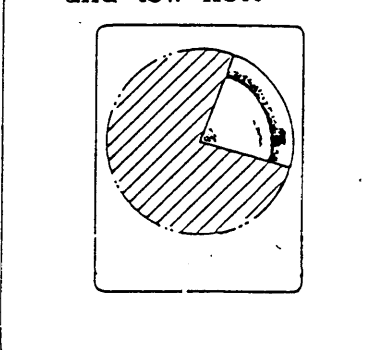

5 Observe movement of fish school and scout-boat.

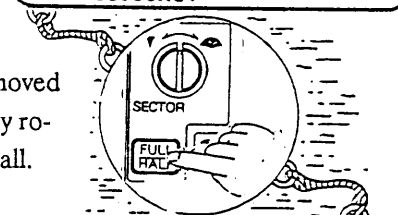

6 Set net around fish school.

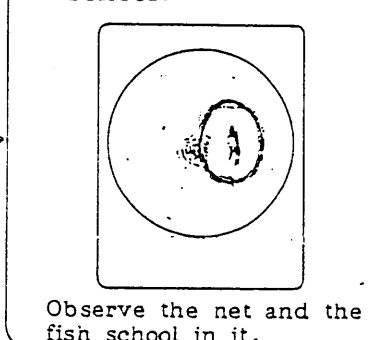

Marker can be moved to any position by rotating the trackball.

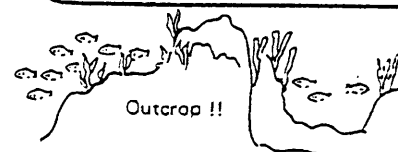



For bottom trawling, sonar is usually used to detect net "hangs" ahead rather than to detect fish close to the bottom, since seabed returns usually mask the weaker fish targets close to the seabed. If the fish school is dense enough and off the seabed they can be detected by sonar.

DO NOT FORGET TO RETRACT THE SOUNDOME BEFORE TURNING OFF THE POWER !!

CHAPTER 3. VERTICAL FAN MODE OPERATION

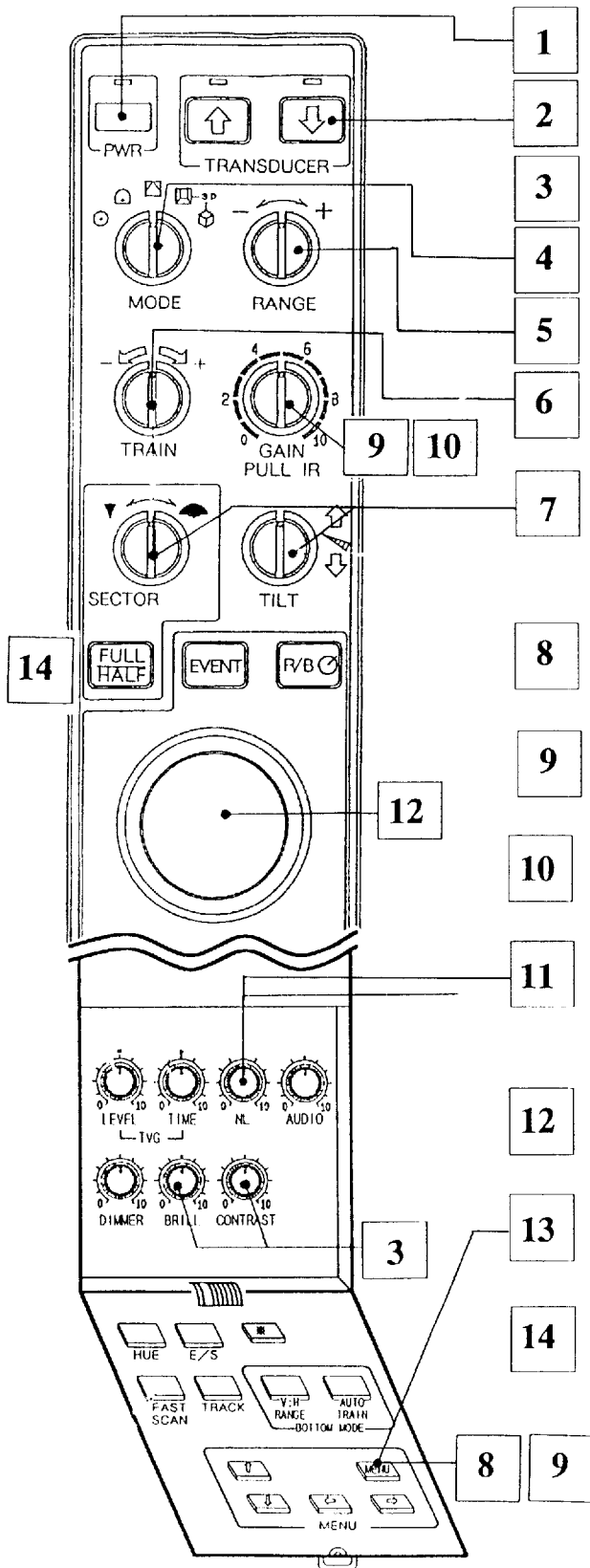
3-1. OPERATING PROCEDURE



- 1 Turn on the display unit.
- 2 Lower the transducer.
- 3 Adjust the contrast and brilliance of the CRT.
- 4 Set the MODE knob to  position.
- 5 Select the range desired with the RANGE switch.
- 6 Select the bearing of the vertical scanning with the TRAIN knob.
- 7 Determine the center direction of the vertical scanning sector with the TILT control knob and select the sector width with the SECTOR knob.
- 8 Select the auto train sector on menu screen, if necessary.
- 9 Adjust the GAIN and TVG controls (Menu screen). [Gain: 3 - 5, TVG(level & time): 3]
- 10 If interference is on the screen, pull out the GAIN (IR) control.
- 11 Adjust the NL control if a large number of small blue dots appear on the screen. Normally set it between "2" and "4".
- 12 With the trackball marker, measure the horizontal or vertical distance to a fish school or the seabed.
- 13 Reduce the output power if necessary. Normally, set it for maximum position (C).
- 14 The FULL/HALF key provides a quick change of the sector (120° or 180°)

Range Selection

The RANGE control selects the detection (display) range. Select the range according to either the fish species being searched or the depth desired. Normally it is set so that the bottom is traced at the lower part of the screen (like an echo sounder).

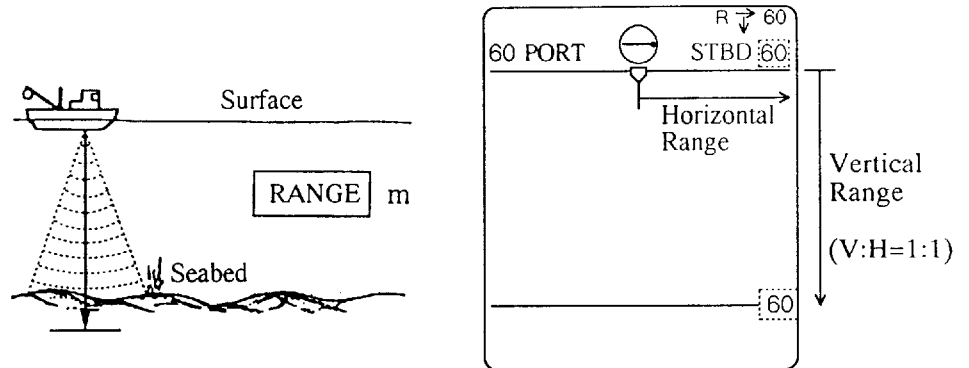

	- ← RANGE → +
Range (m)	20 40 60 280 320 400

■ **NOTE:**

The unit of measurement can be changed through the system menu. See appendix AP-2.

V:H RANGE key

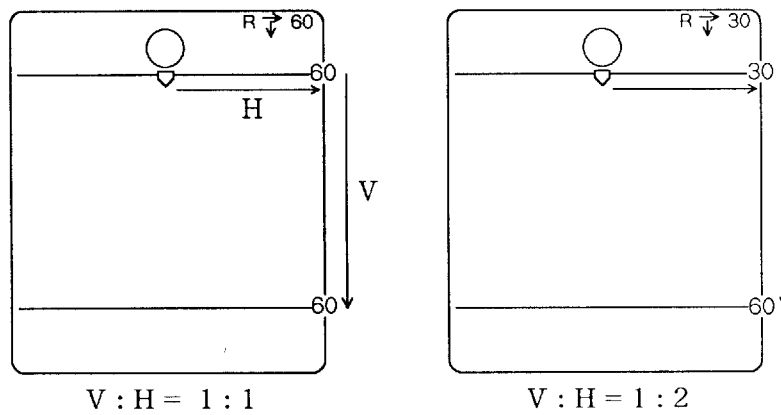

The V:H RANGE key changes the horizontal range scale in two steps. See the figures follow.

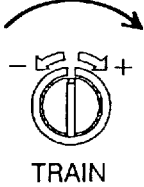
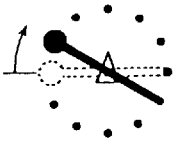
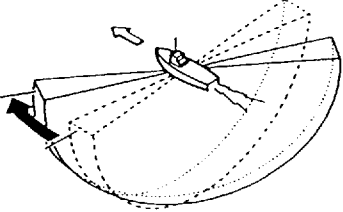

Selecting the Bearing of the Vertical Fan The TRAIN knob determines the bearing of the vertical fan beam. To which bearing the fan beam positions is known by the train indicator mark.

	Train Indicator Mark	Training of Vertical Fan Beam
 <p>TRAIN</p>	<p>Bow</p> 	<p>Bow</p> 

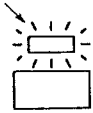
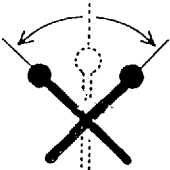
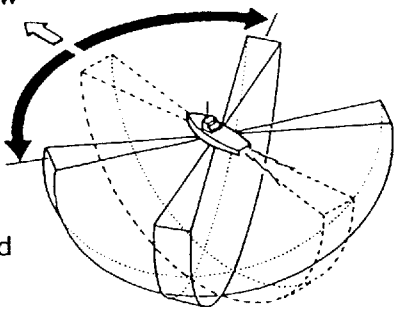
The training of the fan beam depends on the train mode settings, AUTO TRAIN on or AUTO TRAIN off. The selection is made on the sub-panel 2.

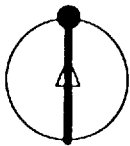
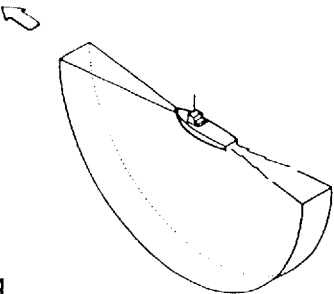
	Train Indicator Mark	Training of Vertical Fan Beam
<p>AUTO TRAIN [on] (LED lights.)</p> 	<p>[Example] Auto Train Sector: 90°</p> 	<p>Bow</p> <p>[The beam trains automatically within the selected range centered at the bearing set by the TRAIN knob.]</p> 
<p>AUTO TRAIN [off] (Manual train) (LED goes off.)</p> 	<p>Bow</p>  <p>Manual train range can be selected either HALF (174°) or FULL (360°) on the system menu.</p>	<p>Bow</p> <p>[The TRAIN knob can rotate the fan beam to any bearing as required.]</p> 

Selecting the Display Sector (center and width)

The SECTOR and the TILT knobs determine the display area (sector width) and the display center (sector center) respectively.

Mode	Display Sector (transducer tilting sector)						
Vertical Fan Mode	36°	60°	96°	120°	156°	and	180°

■ **NOTE:**
Sectors appearing in shading in the table above are selected by the FULL/HALF key.

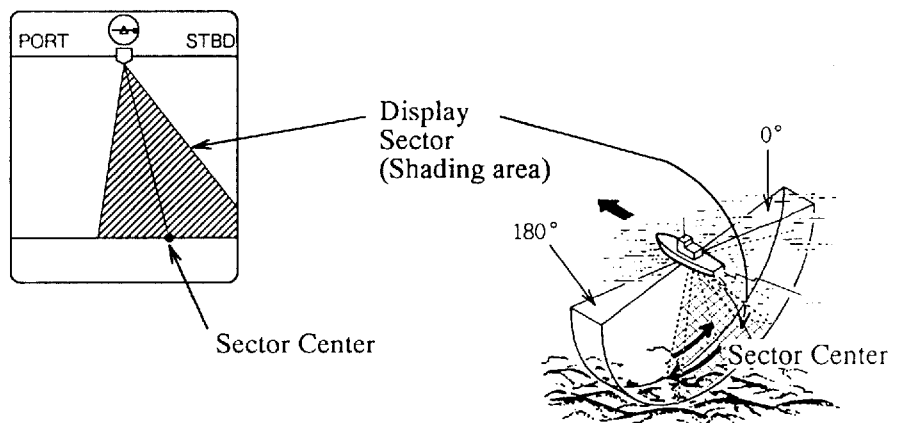

Auto Shift of the Own Ship's Position

The own ship's position on the screen is shifted automatically either rightward or leftward according to the direction of the sector center and the display sector width.

The figure follows shows the own ship's position shifts rightward on the screen to provide the wider view at port side.

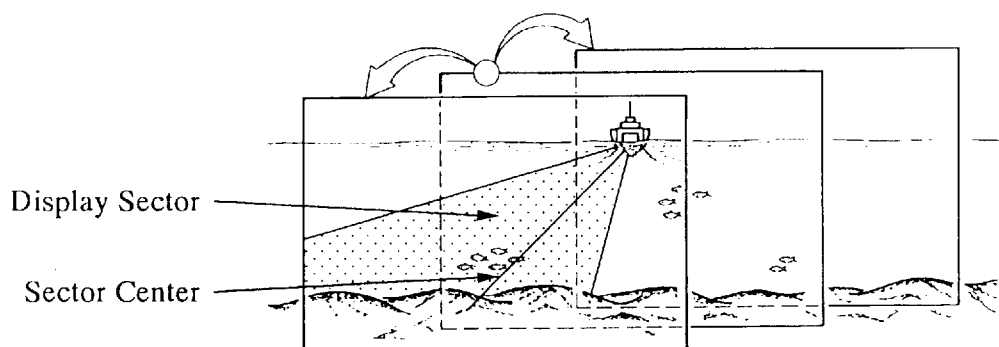

Rejecting Sonar Interference and Noise

While observing the picture, you may encounter occasional or intermittent noise and interference as shown below. This is mostly caused by onboard electronic equipment, engine, propeller noise, or electrical noise from other sonars being operated nearby. Pull the IR (interference rejector) knob to reduce or eliminate the interference.

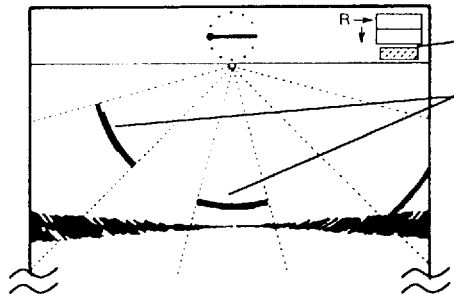

Using Horizontal Mark, Vertical Mark and Event Mark (trackball operation)

The trackball has two functions basically.

- (1) To obtain the data (horizontal range and depth) from own ship to the specified position on the screen.
- (2) Combined with the R/B and EVENT keys, the Horizontal, Vertical and EVENT mark are switched on and off.

Function	Procedures/Purpose
Trackball Data	<div style="text-align: center;"> </div> <ol style="list-style-type: none"> 1) Position the trackball marker on the desired location. 2) Read the trackball data displayed at the upper left corner of the screen.

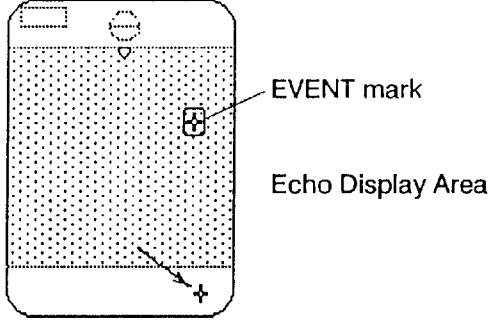
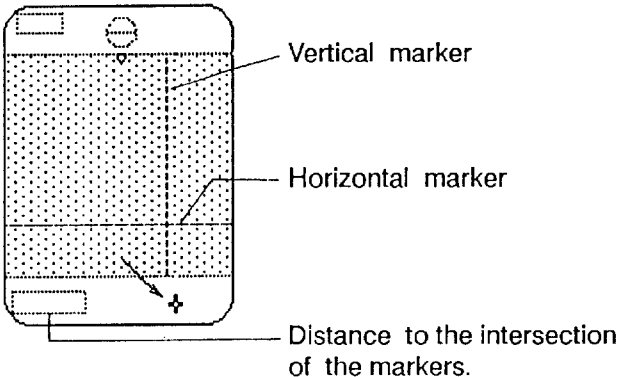
<p>EVENT mark*</p>	<p>1) Position the trackball marker on the desired location.</p>  <p>2) Press the EVENT key. The EVENT mark appears.</p> <p>3) To erase the mark, place the trackball mark outside the echo display area and press the EVENT key.</p> <p>Note: * Optional supply. CH-36 holds one EVENT mark.</p>
<p>Horizontal and Vertical markers</p>	 <p>1) Position the trackball marker on the desired location.</p> <p>2) Press the R/B key. The horizontal and vertical markers appear and the distance to the intersection of the markers is indicated at the bottom left-hand side of the screen.</p> <p>3) To erase the Marker;</p> <p>Place the marker outside the echo display area and press the R/B key.</p>

3-2. FINE TUNING THE PICTURE

Applying a Proper TVG

The TVG function is the same as the one explained in the sonar mode. However, the unwanted echoes and noises are little reduced in the vertical mode operation. You can get a good result by setting both TVG level and time a little lower than the ones in the sonar mode. The setting is made on the BOTTOM/3D menu screen and recommended level is "3" in most case.

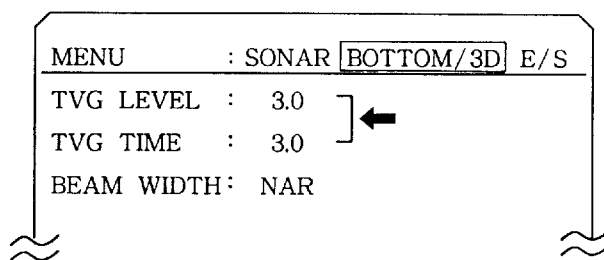

TVG level rejects surface noise, which may mask shallow targets and TVG time adjusts the effective depth.

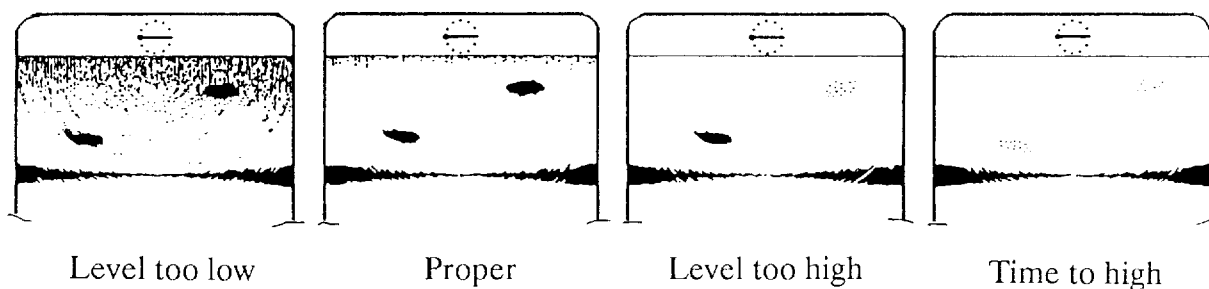

3-3. MENU SCREEN

- Operating Procedure**
- (1) Press the MENU key on the Sub-panel 2.
 - (2) Select the bottom/3D (for vertical fan mode).
 - (3) Select item with the horizontal arrow key and set parameters with the vertical arrow key. The selected item is highlighted and the current setting is circumscribed in white.
 - (4) To turn off the menu, press the menu key again.

Bottom/3D Menu (vertical fan mode)

MENU	:	SONAR	BOTTOM/3D	E/S
TVG (LEVEL)	:	3.0		
TVG (TIME)	:	3.0		
BEAM WIDTH	:	<input type="text" value="NAR"/>	WIDE	
AUTO TRAIN SECTOR	:	90	180	<input type="text" value="360"/>
VERT. ECHO OVERLAY	:	OFF	<input type="text" value="ON"/>	
3D VIEW SCALE	:	<input type="text" value="TIM"/>	DIST	
TIME SCALE (or DISTANCE SCALE	:	<input type="text" value="1/1"/>	1/2	1/4
		500	1000	
EXIT	:	PRESS MENU KEY		

Contents of Bottom/3D Menu

Menu Item	Meaning
TVG (Level)	Controls the receiver sensitivity in short to medium ranges to eliminate surface noise, which may mask shallow targets.
TVG (Time)	Determines the TVG effective depth.
BEAM WIDTH	Sets the vertical beam width. Select narrow for general use. The wide beam width is useful for searching a wide area vertically but fish detection range is shortened since the transmitted power attenuates.
AUTO TRAIN SECTOR	Sets the train sector; 90, 180 or 360 (in degrees). Use a wide sector to conduct a general search, narrowing it once a fish school is detected.
VERT. ECHO OVERLAY	Turns the E/S combination display on and off. (External E/S required.)
3D VIEW SCALE	Determines the depth item, time or distance for 3D display mode.
TIME SCALE or DISTANCE SCALE	Selects z-axis scale of 3D picture.

■ **NOTE:**

The items appearing in shading in the table require optional equipment. Consult with your agent or dealer for further information.

3-4. INTERPRETING THE DISPLAY

This section provides the information necessary for interpreting the display.

How the Picture is Painted.

The sounding beam is emitted and the information (target echoes) obtained by the beam appears in the corresponding sector as it appears on the sonar mode. The difference is that the training is performed only in vertical direction. It forms a sounding area of half-circle (like a slice of watermelon) to observe the vertical section of underwater conditions.

The bearing of this vertical sounding beam can be selected manually or automatically.

	Sounding Beam	Screen Display
Vertical Fan Mode	<p>Freq: 60 kHz</p> <p>(1) Bearing of the sounding beam</p> <p>Bow</p> <p>180°</p> <p>0°</p> <p>Tilting direction</p> <p>(2) Sector center</p> <p>(3) Display area</p> <p>TX</p> <p>16°</p> <p>13°</p> <p>RX</p> <p>16°</p> <p>13°</p> <p>Select the bearing of the sounding beam (1) by TRAIN knob, the sounding sector center (2) by the TILT knob and the display area (3) by the SECTOR knob.</p>	<p>(1) Bearing of the sounding beam</p> <p>180°</p> <p>0°</p> <p>(2) Sector center</p> <p>(3) Display area</p>

**Port-starboard
Picture (seabed)**

You can see fish echoes at the center-right of the CRT. The seabed is displayed wider as the distance from the ship's position increases. Therefore, it may be difficult to discriminate bottom fish.

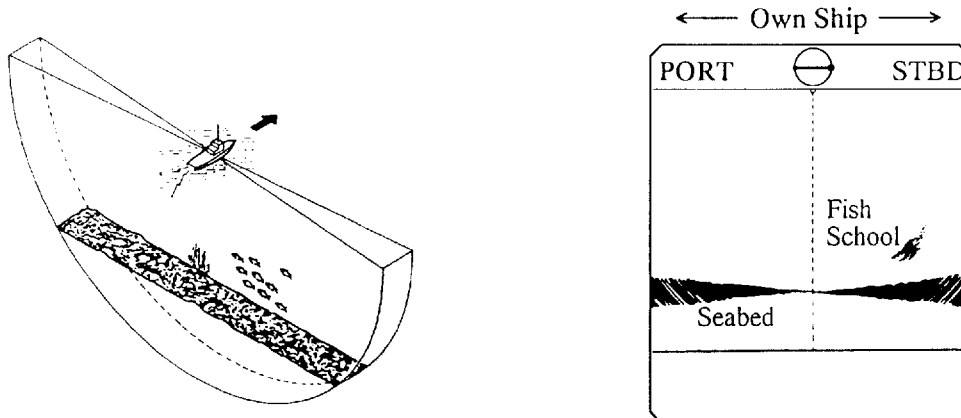

**The ship is passing
over fish schools.**

The sounding beam is directed fore-aft and the display is off-centered* to present a wider view of the area forward of the ship. You can clearly see fish schools approaching from the bow of the ship.

*: automatically shifted according to the operation control settings.

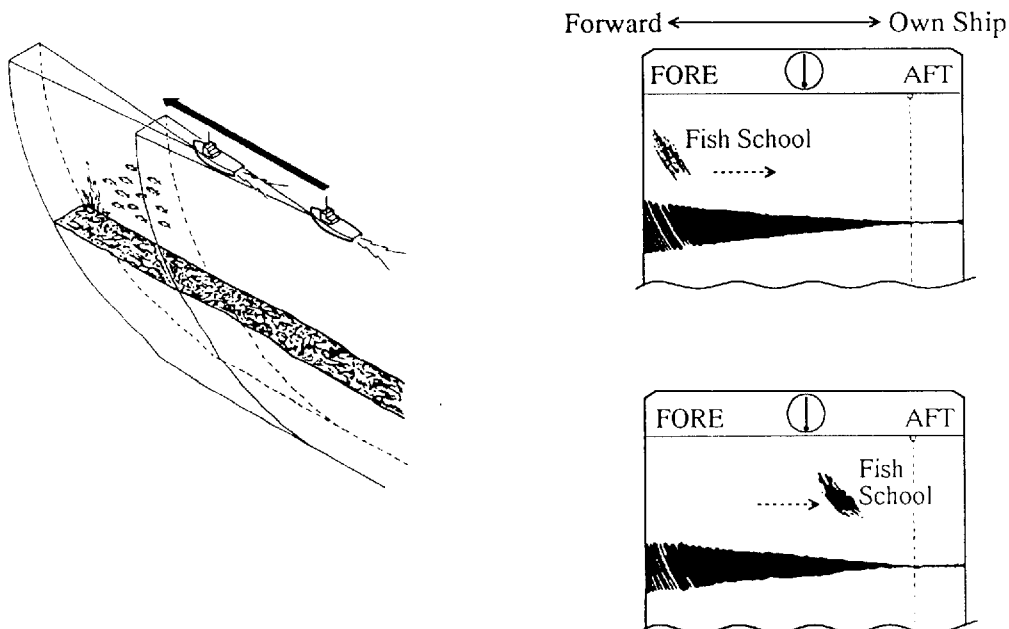

Display of Net Hauling

This is an example of net hauling display. The location of the net is indicated clearly. (Ship is stopped.)

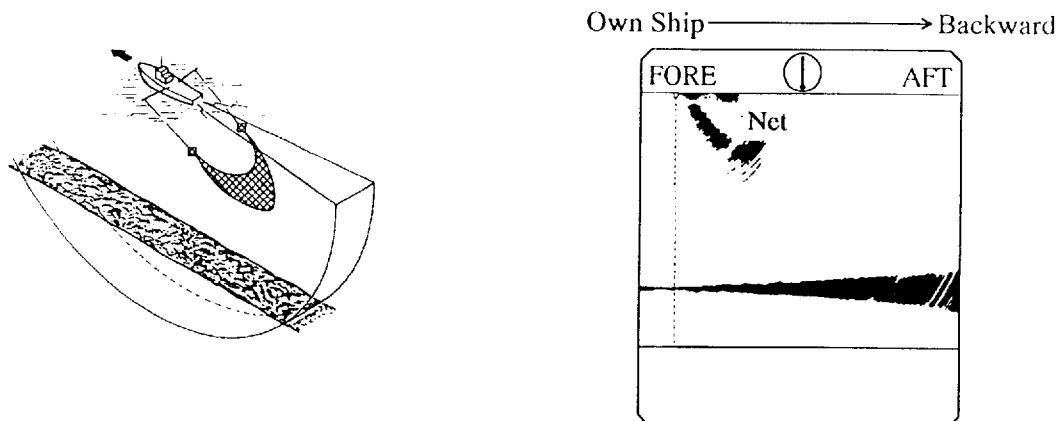

False Echo

In a shallow water (less than 100m) detection, unwanted echoes shown in the figure may appear. This phenomenon is caused by the false echo from the previous transmission. Reducing the TX RATE on the menu may lessen this effect.

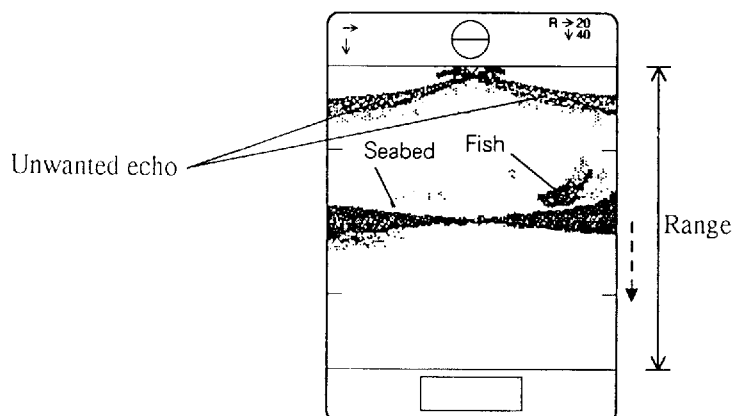

TIP! Training indicator and screen display

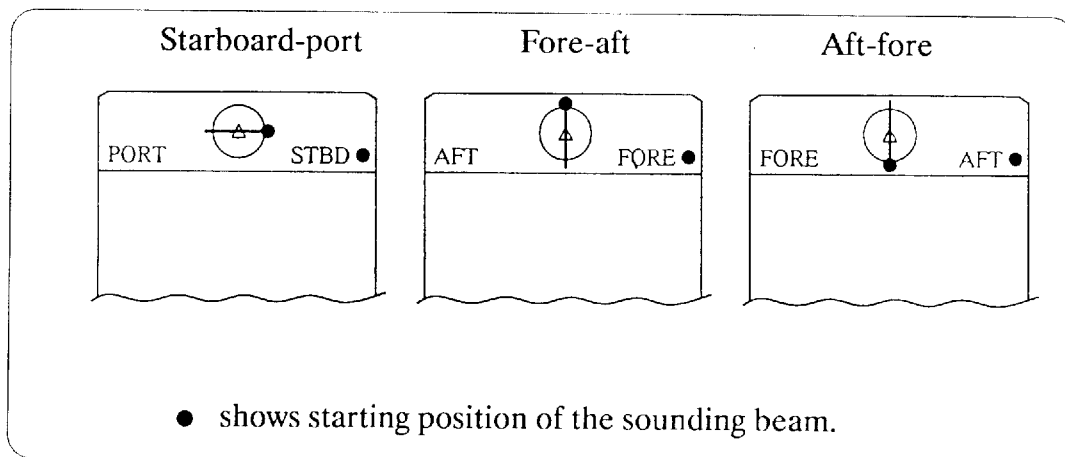

3-5. Indications on the Screen

Vertical Fan Mode

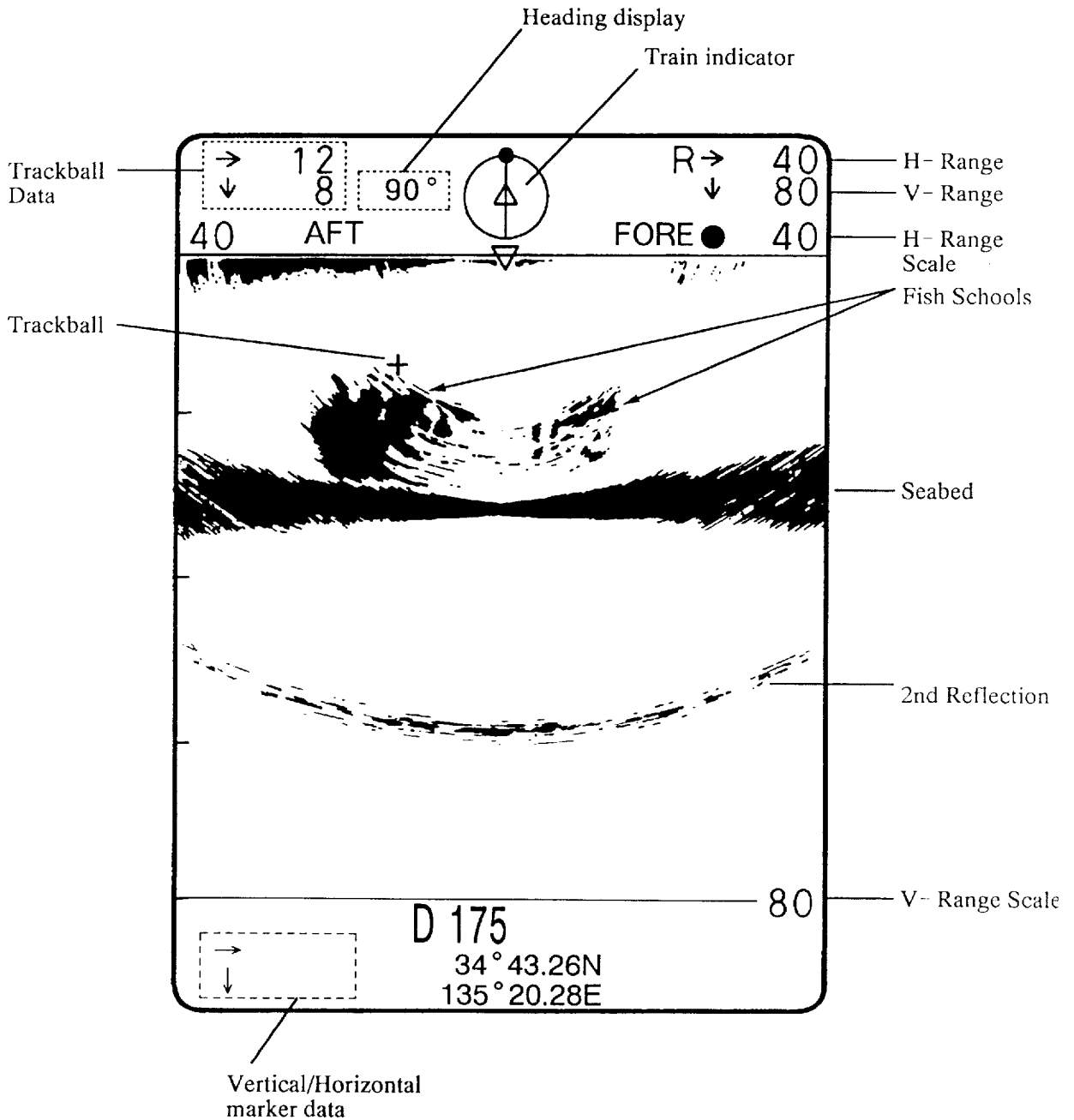

3-6. EXAMPLES OF APPLICATION

[1] TRAWL (Surface/Mid-water/Bottom)

- Usage —
- Fish school detection
 - Bottom shape discrimination
 - Relation between fish school and fishing gears

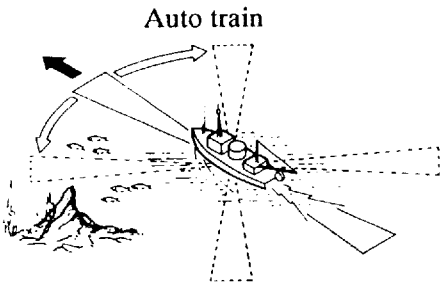

1 Turn on "AUTO TRAIN" function on the sub-panel and set the direction of the train center to the fore-aft direction. Observe the fish school near the bow of the ship, or inspect the bottom contour.

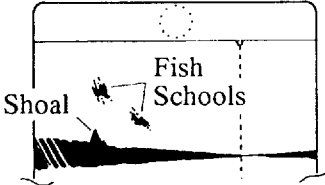

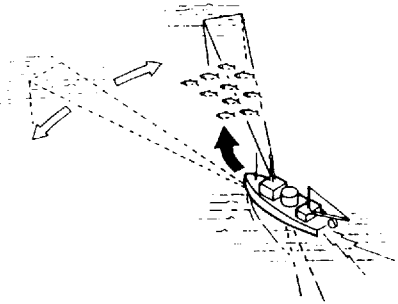

2 After detecting a fish school, steer the boat toward that direction turning off the "AUTO TRAIN" to observe that direction.

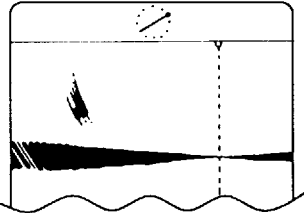
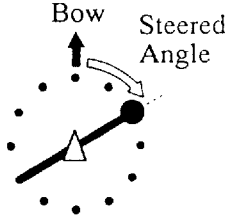

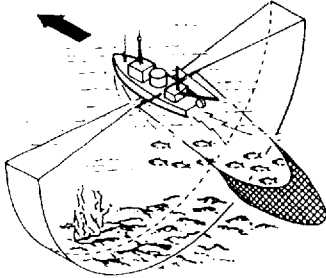
3 When approaching the fish school, change the beam direction to port-starboard by the TRAIN knob and maneuver the boat so that the fish are led into the trawl net.

4 Be careful of reefs, etc., so as not to damage the net.

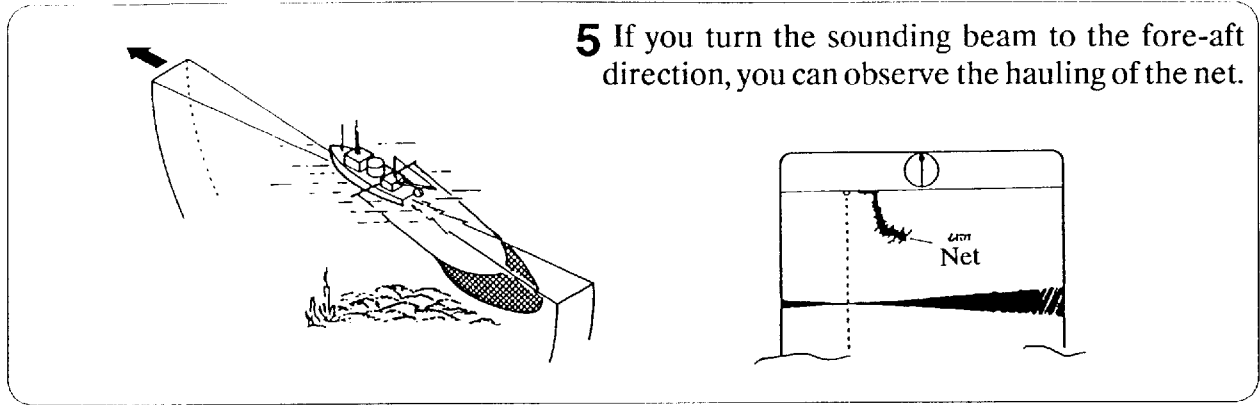

[2] PURSE SEINE

- Usage — Tracking of Fish
 — Observation of fish Movement/bottom shape
 — Confirmation of net forming

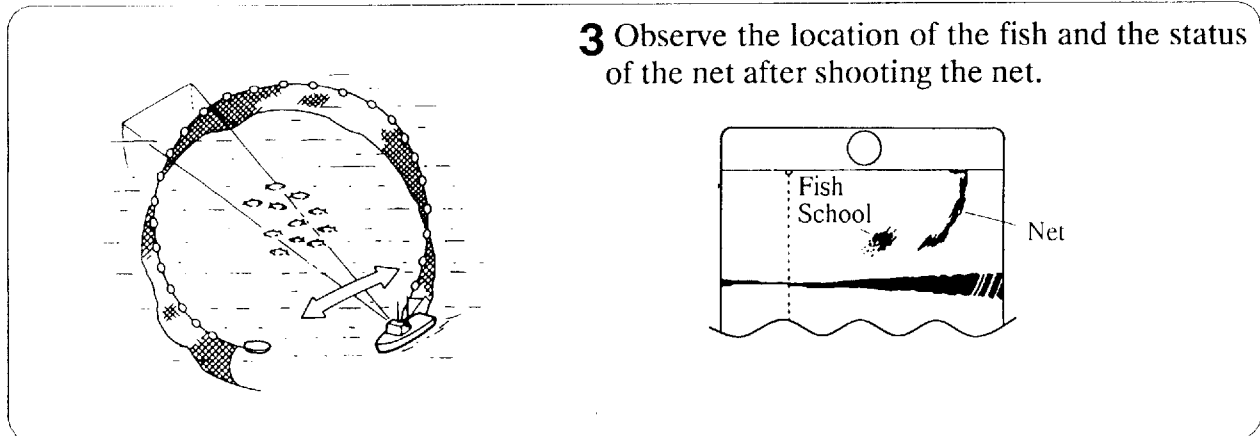
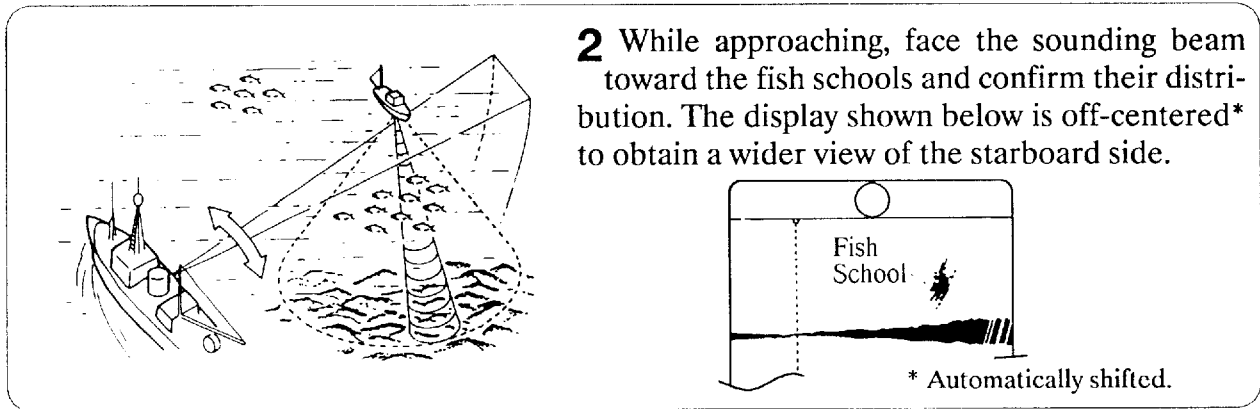
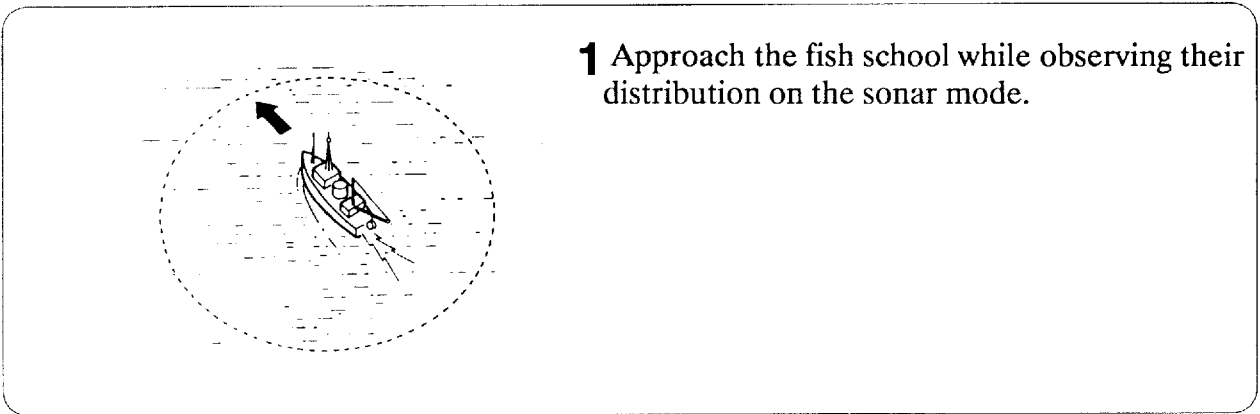

CHAPTER 4. USING CUSTOM MODE KEY

4-1. USING THE CUSTOM KEYS

Like the redial feature on a telephone, the CUSTOM MODE keys record control settings and play them back by one key stroke. This feature is useful when you need to quickly set up the sonar according to fishing ground or fish species being searched. you can program three sets of settings for the MODE, RANGE, SECTOR, TRAIN and TILT controls.

Customizing the keys

- (1) Tune the sonar as you normally would.
- (2) Press the ENTER key to display the custom mode menu. Press one of [1], [2] and [3] keys to which the settings (contents shown in second column from the left) are registered.

[Custom mode menu]

ITEM	SETTING	CUSTOM1	CUSTOM2	CUSTOM3
MODE	△ FAST			
RANGE	60			
SECTOR	0°			
TRAIN	180°			
TILT	96°			



- (3) Repeat the step (2) for remaining CUSTOM MODE keys.

Custom mode operation

- (1) Press desired custom key [1], [2] or [3]. To escape from the custom settings, adjust the controls as you would.

■ NOTES:

- 1) This manual contains memo label on page AP-6 to note the customized items. Cut out and insert it to the label case on the front panel. See the illustration on next page.
- 2) The unit starts with the settings used before the power is switched off.
- 3) While working with a CUSTOM mode, you may change the MODE, RANGE, SECTOR, TRAIN and TILT controls.

[Example]

FISHING GROUND		
MODE <input type="radio"/>	MODE <input checked="" type="checkbox"/>	MODE
RANGE 200m	RANGE 100m	RANGE
SECTOR 360°	SECTOR 180°	SECTOR
TRAIN 0°	TRAIN 90°	TRAIN
TILT 30°	TILT 90°	TILT

Fold here

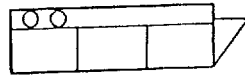

Insert the memo label to the label case on the front panel.

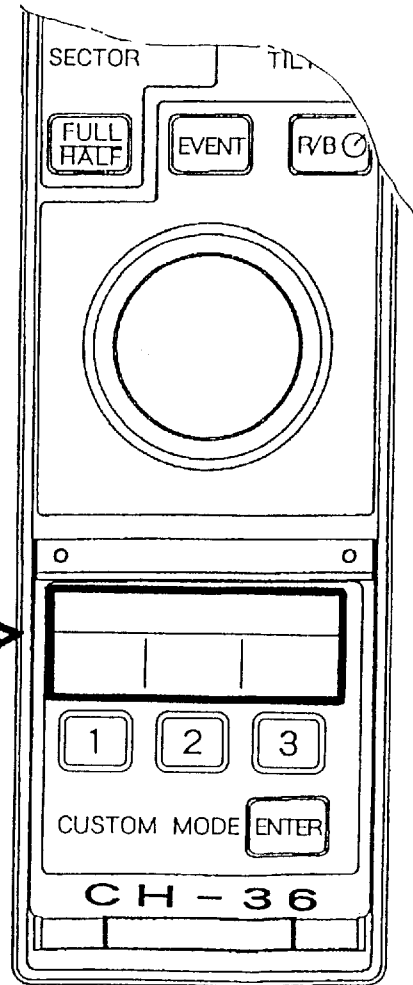

CHAPTER 5. MAINTENANCE AND GENERAL NOTES

Good performance depends on regular maintenance. Following the guidelines below will keep the unit operating in top condition.

5-1. DISPLAY UNIT

1. Handle with care. Corrosion may start even from a scratch.
2. DO NOT check inside the unit because of high tension voltage which exists there.
3. Allow space around the unit for ventilation.
4. Keep it away from equipment with magnets (such as a speaker, large capacity transformer) and also magnetic-sensitive units such as gyrocompass or cassette tape.
5. Clean the filter and screen with a wet or dry soft cloth. Don't use thinner or benzine.
6. Put on the cover after operation.
7. Demagnetize the display when irregular picture color appears.

5-2. TRANSCEIVER UNIT

Keep the unit clean, especially the cable entrance. Wipe off dust or oil with a cloth dampened in water-diluted mild detergent.

5-3. HULL UNIT

Lubrication

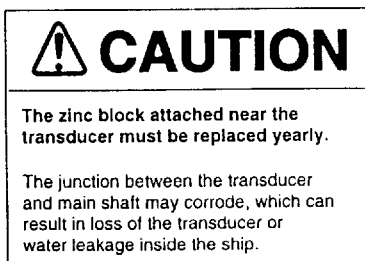

Grease the raise/lower screw shaft once a year. Also, grease the raise/lower main shaft (upper part of the grease cotton retainer) twice a year. These parts can be accessed by removing the raise/lower drive assembly cover.

Manual Raise/Lower of Transducer with Hand Crank

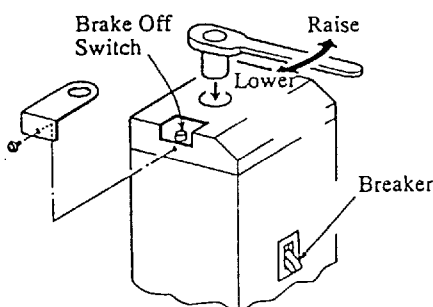

Ship's mains should be supplied to the hull unit. Otherwise the magnetic brake of the raise/lower motor operates, disabling the manual raise/lower.

1. Turn off the breaker on the hull unit.
2. Remove the brake-off switch cover.
3. Set 19 mm socket wrench and turn it while pressing the brake-off switch.
4. Check that the transducer can be raised/lowered smoothly with a constant force from the upper to the lower limit positions. If not, centers of the main body flange and the retraction tank are not aligned. Adjust the hull unit mounting position.

Cleaning Retraction Tank (removal of marine growth)

If marine organisms (barnacle, oyster, etc.) breed inside the retraction tank, the raise/lower operation will be obstructed. In the worst case, the raise/lower motor may burn out. Therefore, it is necessary to remove them at least once a year or when the ship is hauled on the slip or in the dry dock.

If the sonar has not been operated for a considerably long period, scrape off marine organisms inside the tank before operation.

Scrape off marine organisms and coat the inside of the tank with antifouling paint.

Soundome
Do not clean the dome surface with thinner or alcohol and never paint it.

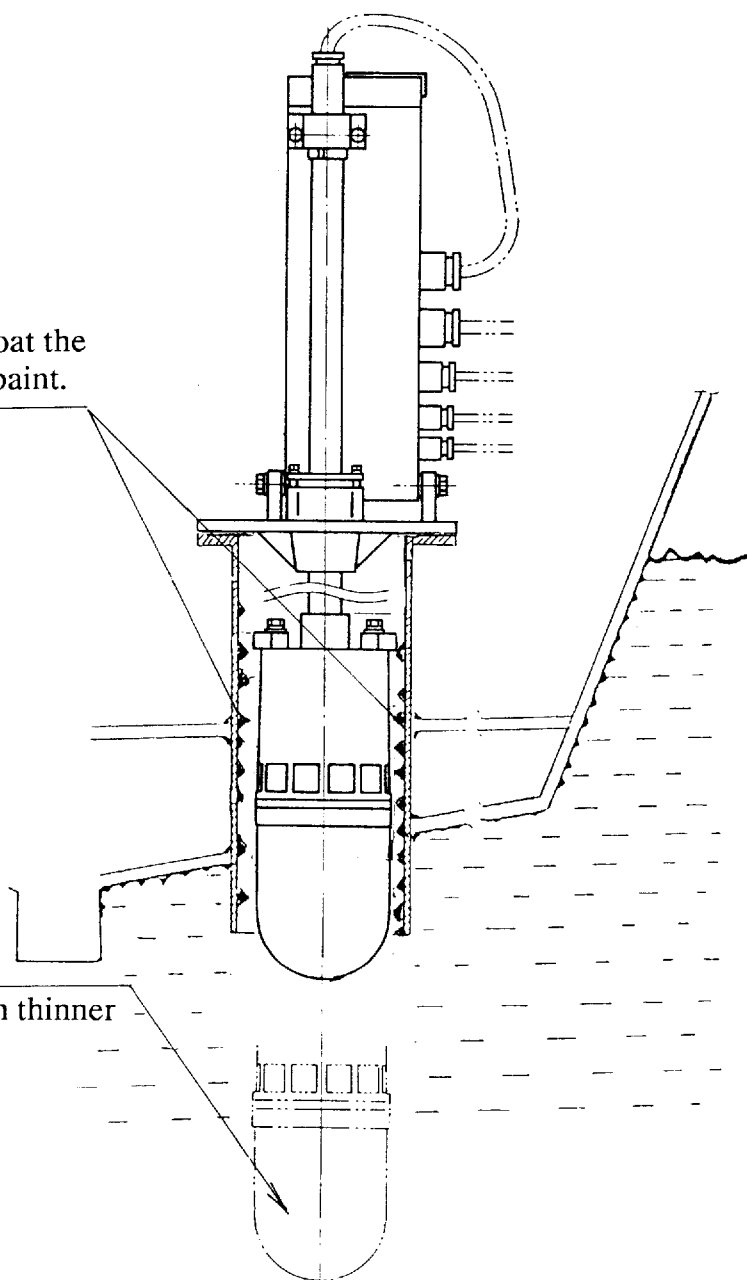

Replacement of the Grease Cotton Rings

Replacement of the grease cotton is required every two years or when water penetrates along the main shaft. For a ship whose waterline is higher than the flange level, though water penetration into the ship is prevented by the O-ring fitted at the bottom of the main body flange, it is recommended to replace the grease cotton rings with the ship hauled up.

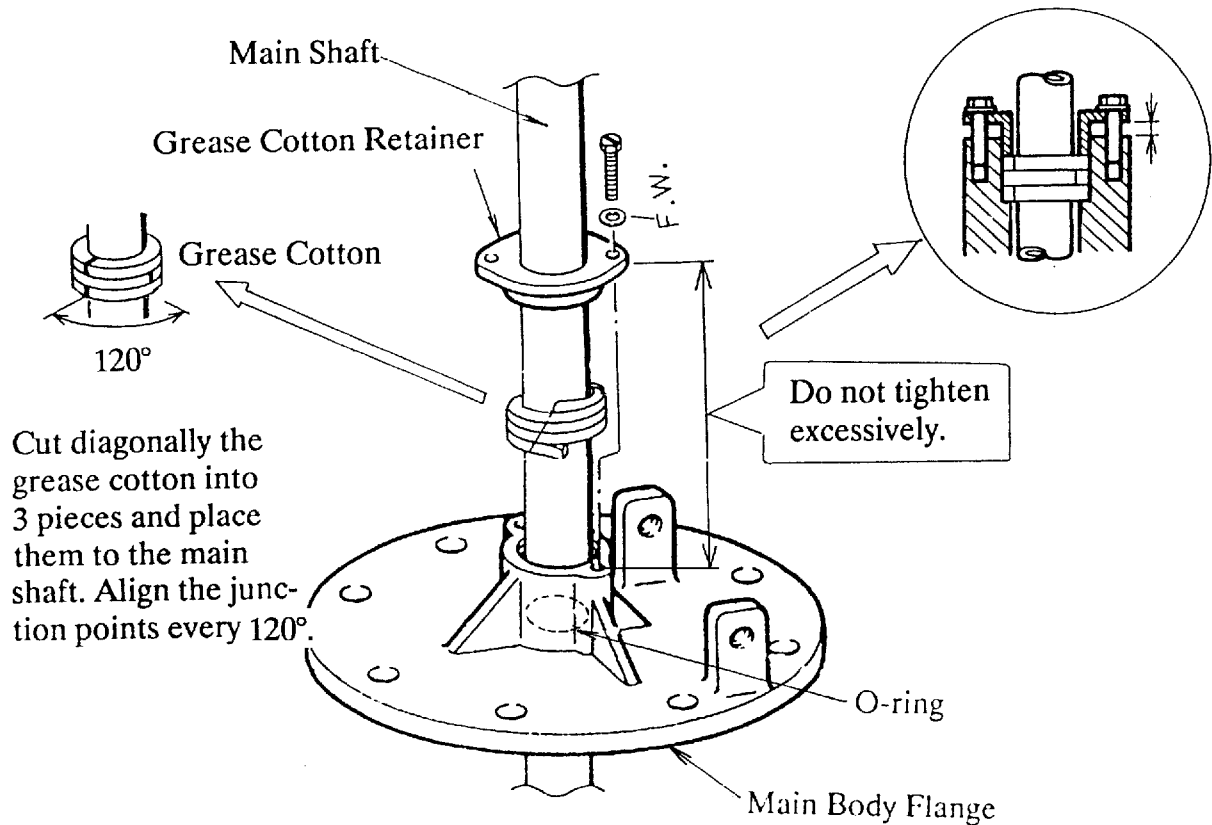

CHAPTER 6. TROUBLESHOOTING

6-1. SELF-CHECK

The CH-36 has built-in diagnostic self-checks to check it for proper operation. Execute the self-check if the equipment does not start displaying the message "WAIT" when the power is turned on.

When an error message appears during operation, follow the instruction on the screen.

Turning on and off Self-check

1. While pressing and holding down the EVENT key, turn on the power. Release the EVENT key when you have a beep. The self-check menu appears as shown below.

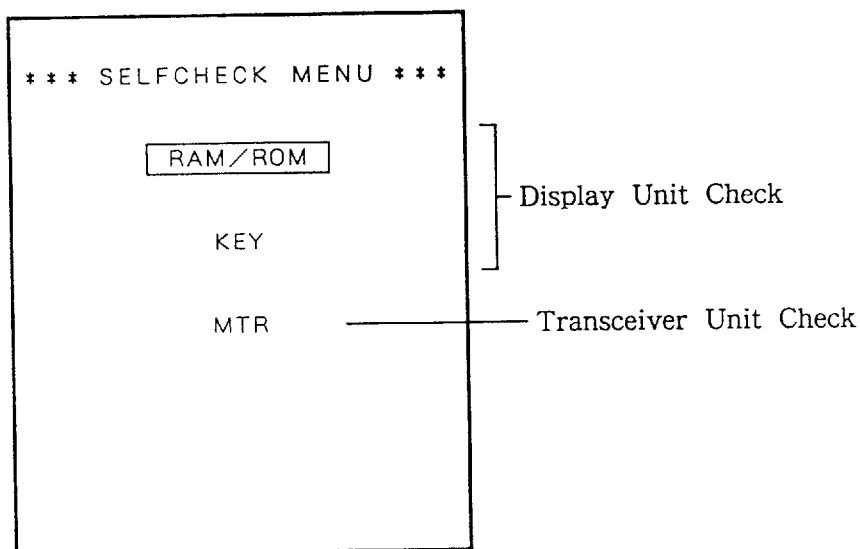

2. Select an appropriate self-check by operating arrow keys on sub-panel 2.
3. Press the MENU key to execute the self-check.
4. To return to the self-check menu, press the MENU key again.
5. To exit from the self-check screen, turn off the CH-36.

Description of Self-checks

RAM and ROM Check

This checks the major circuits in the display unit for proper operation. Program numbers of DISP, MTR and I/F boards appear, and RAM and ROM are checked for proper operation.

DISP UNIT	
PROGRAM NO.	065-0055-100
	065-0055-200
DATA ROM VER.	065-0056-100
BACKUP VER.	1
ROM	OK
RAM	OK
DATA ROM	OK
BACKUP RAM	OK
MTR UNIT	
PROGRAM NO.	061-0057-100
ROM	OK
RAM	OK
I/F UNIT	
PROGRAM NO.	105-267-002
ROM	OK
RAM	OK

If the interface board (option) is not incorporated, no check results appear for the items circumscribed by dotted lines in the figure above.

KEY Check

This checks the operating switches on the main panel for proper operation. Press each switch one by one if the value changes, the switch is normal.

PANEL		REMOTE CONTROL	
		TRANSDUCER RANGE	
MODE : 3	RANGE : 2	↑ : 0	↓ : 0 + : 0
		MODE	
TR. : 0	GAIN 255	← : 0	→ : 0 - : 0
		TRAIN TILT	
SECT : 2	TILT : 0	CCW : 0	CW : 0 ↑ : 0
F/H:0	EVENT:0 R/B:0	SECTOR:0 ↓ : 0	
TRACK X : 0		1 : 0	2 : 0 3 : 0
BALL Y : 0		-----	
		LEV:128 TIM:117 NL:0	
1 : 0	2 : 0 3 : 0	HUE : 0	E/S : 0 * : 0
ENTER : 0		FAST : 0	TK : 0 V : H : 0 AT : 0
		↑ : 0 MENU : END	
ROLL : 0.0		↓ : 0 ← : 0 → : 0	
PITCH : 0.0			

MTR Check

This checks the transducer training and tilting functions for proper operation.

TRAIN/TILT SELF CHECK					
-- PHOTO SENSOR --					
	TRAIN		TILT		
0°	NG	+ 10°	NG	NG	
180°	NG	90°	NG	NG	
		190°	NG	NG	
-- TRAIN CHECK --					
	CW		CCW		
0°	PULSE	NG	PULSE	NG	
	*1428	5	1451	3	
180°	1449	4	1427	4	
0°					
-- TILT CHECK --					
+10°	PULSE	NG	PULSE	NG	
	1206	3	*1225	3	
90°	939	3	919	3	
180°					
TEST COUNT =					8

This checks the photo sensors which detect the reference angles for training and tilting operations.

This checks the transducer training operation. The four digit figures show the number of pulses used to train the transducer by 180. If training is abnormal, NG (No Good) count increases by one.

This checks the transducer tilting operation. If the number of pulses used to tilt the transducer is abnormal, NG count increases by one.

6-2. ERROR MESSAGES

Raise/lower Error Message

If the power is not applied to the hull unit, the following message appears on the screen and an alarm sounds.

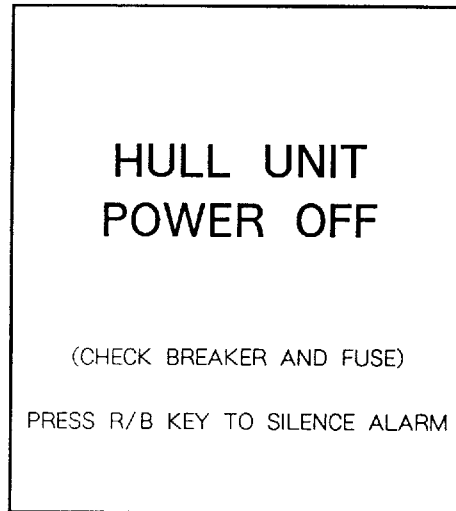

If this occurs, turn the **POWER** off and check the breaker and fuse as the screen suggests.

Transceiver Unit Error Message

If the power is not supplied to the transceiver unit, the following message appears on the screen and an alarm sounds.

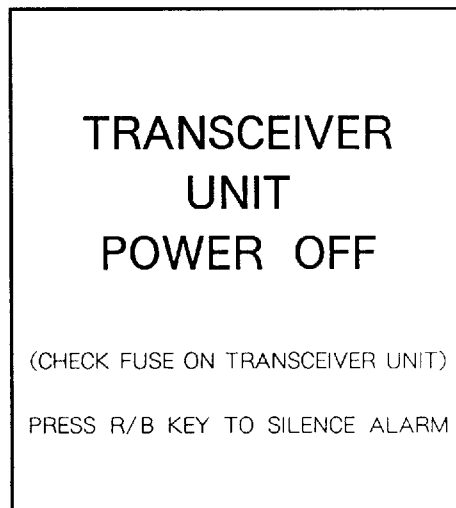

If this occurs, turn the power off and check the fuse as the screen suggests.

Ship's Speed

Because the transducer may be damaged if kept lowered when the ship's speed exceeds 15 knots*, the following message appears and the alarm sounds.

*: Based on the speed relative to ground fed from nav sensor.

Press the R/B key to silence the alarm and return to the normal sonar picture.

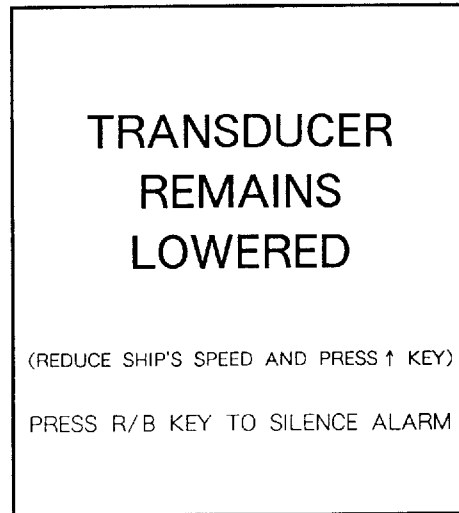

Training Error Message

If something is wrong with the training control circuit, the following message appears and the unit stops operating. Turn the POWER switch off and call your service agent at your earliest convenience.

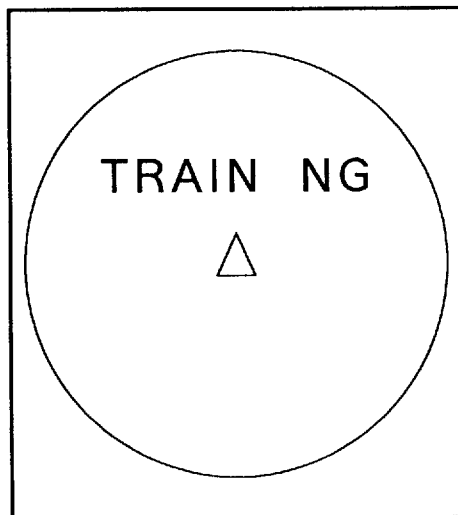

Tilt Error Message

If something is wrong with the tilting control circuit, the following message appears and the unit stops operating. Turn the POWER switch off and call your service agent at your earliest convenience.

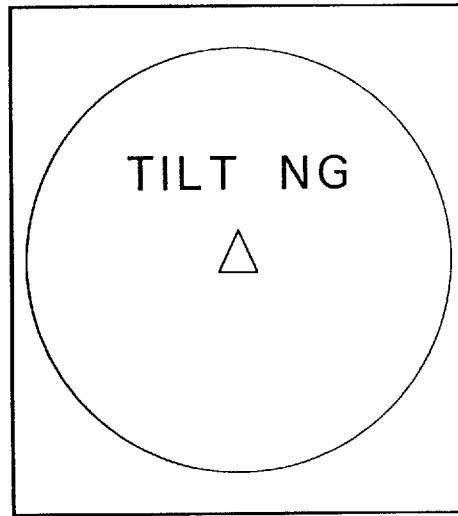

6-3. TROUBLESHOOTING

The table which follows provides common symptoms of equipment troubles and the means to rectify them. If normal operation cannot be restored, do not check inside the unit. Any repair is best left to a qualified technician.

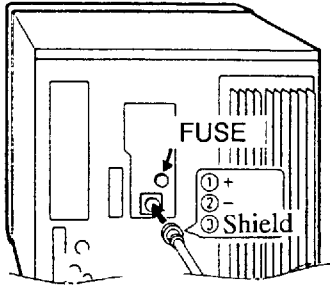
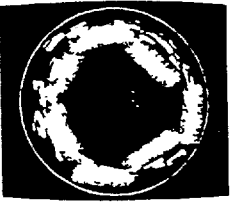
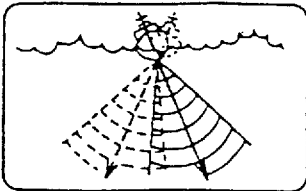
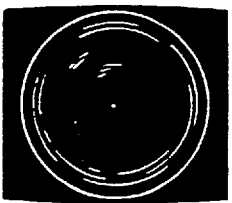
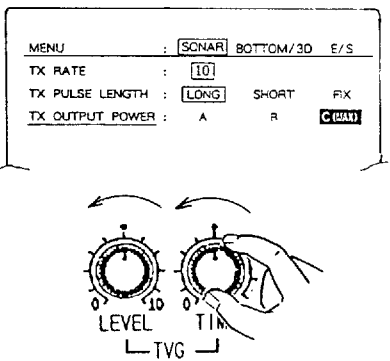
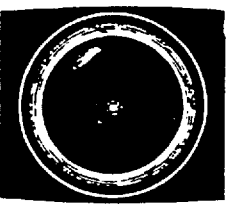
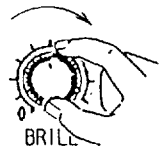
Symptom	Check	
<p>No picture</p> 	<p>Power supply. Check ship's mains voltage at the power plug connected to the power unit.</p> <p>Fuse. If blown, replace. Call service technician if it blows again. NEVER use a fuse of a higher rating.</p>	
<p>Bottom echo becomes irregular</p> 	<p>Rough seas. Distance to sea bottom changes due to rolling and pitching.</p> <p>Long range selected. Since transson period is a little longer, ship's rolling and pitching are apt to effect detection of echo.</p>	
<p>Weak echo</p> 	<p>TX OUTPUT POWER set to other than "C". Check the TX OUTPUT POWER setting on the menu, and set it to "C" for max. output power.</p> <p>TVG effect is excessive. Excessive TVG results in elimination of useful echoes.</p> <p>NOTE: Readjustment of TVG is required whenever the GAIN control is adjusted.</p>	
<p>Somewhat strange color</p> 	<p>BRILLIANCE control set too low. Increase the brightness.,</p>	

Color partially irregular

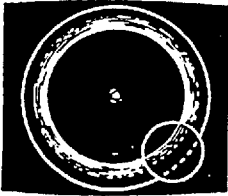

Magnet is near the screen.

This symptom occurs if a magnetic device such as a loudspeaker is near the screen.

NOTE: If not cleared, consult with electronics technician.

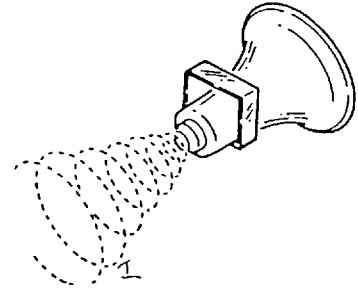

Picture distorted

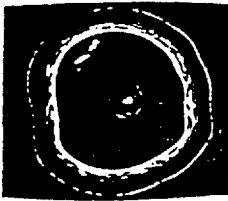

Equipment generating strong magnetic field is near display unit.

Locate magnetic field generating equipment such as rectifier well away from the display unit.

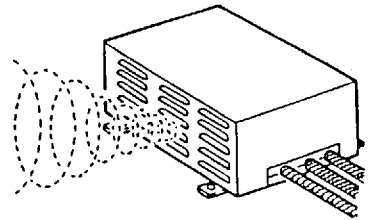

Picture contains noise.

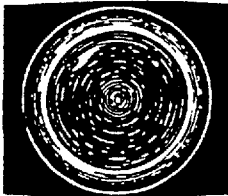

Equipment not grounded properly.
Carefully check the ground.

Power cable is run alongside the signal cable.

Signal cable may pick up noise emitted from power cable of other equipment; therefore, separate them from each other.

Debris may be on sea surface.

Reject unwanted echoes with the IR interference rejector), TVG or NL (noise limiter) controls.

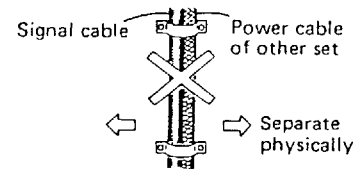
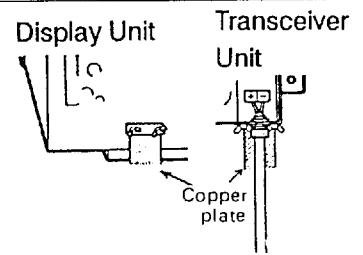

SPECIFICATIONS OF COLOR MULTI-SECTOR SONAR CH-36

- 1. Display System PPI display on high resolution 14" color CRT
- 2. Picture Color 16 or 8 colors depending on signal strength
- 3. Display Mode (1) Normal sonar mode display*
 (2) Expanded sonar mode display
 (3) Vertical fan mode display *
 (4) 3D mode display (front view)**
 (5) 3D mode display (slant view)**

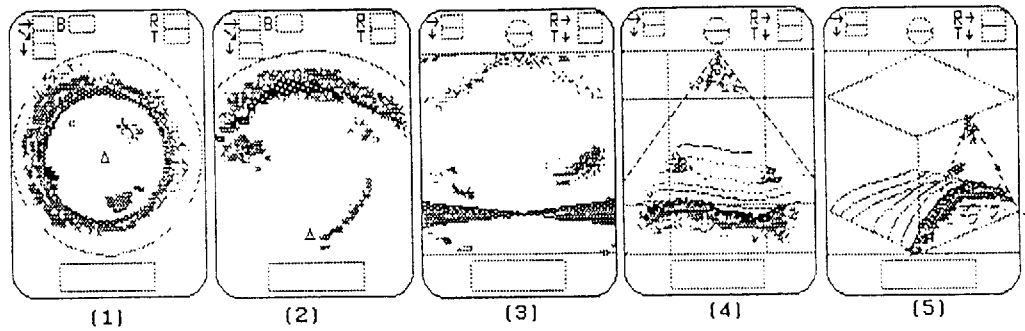

* : E/S combination display is optionally available in modes (1) and (3).
 **: Optionally available.

4. Range/Train Speed

(1) Sonar Mode

	Detection Range				Train Speed* (sec./360°)
	Meter	Feet	Fathom	Remark	
1	0-50	0-200	0-40		3.8
2	0-100	0-300	0-60		4.3
3	0-150	0-400	0-80		4.8
4	0-200	0-600 0-500	0-100	60kHz 162kHz	5.4
5	0-250	0-800 0-600	0-120	60kHz 162kHz	6.4
6	0-300	0-1000 0-800	0-160 0-140	60kHz 162kHz	6.7
7	0-400 0-350	0-1500 0-1000	0-250 0-160	60kHz 62kHz	7.0
8	0-500 0-400	0-2000 0-1200	0-300 0-200	60kHz 162kHz	7.6
9	0-600 0-450	0-2500 0-1500	0-400 0-250	60kHz 162kHz	8.6

10	0-800 0-500	0-3000 0-2000	0-500 0-300	60kHz 162kHz	10.0
11	0-1200 0-600	0-4000 0-2500	0-700 0-400	60kHz 162kHz	12.0
12	0-1600 0-800	0-5000 0-3000	0-900 0-500	60kHz 162kHz	14.0

*: Measured at "Fast Train" mode.

Display sector width is selected among 45°, 90°, 135°, 180°, 225° and 360°.

(2) Vertical Fan Mode

	Vertical Detection Range**			Vertical Scanning Speed* (sec./180°)
	Meter	Feet	Fathom	
1	0-20	0-100	0-20	4.8
2	0-40	0-150	0-30	4.8
3	0-60	0-200	0-40	4.8
4	0-80	0-250	0-50	4.8
5	0-100	0-300	0-60	4.8
6	0-120	0-400	0-70	5.6
7	0-160	0-500	0-80	7.5
8	0-200	0-600	0-100	9.4
9	0-240	0-800	0-120	11
10	0-280	0-1000	0-160	13
11	0-320	0-1200	0-200	15
12	0-400	0-1500	0-250	19

*: Selected "Fast Scan" on the sub-panel 2.

** : Horizontal range is either equal to or 50% of the vertical range.

Display sector width is selected among 36°, 60°, 96°, 120°, 156° and 180°.

(3) Echo Sounder Range

Range	Display Range						Max. Shift Range
	Meter	Feet	Fathom	Unit Shift Range			
1	0-40	0-100	0-20	20M	50F	10FA	1000M 3000FT 500FA
2	0-80	0-200	0-40	20M	50F	10FA	
3	0-160	0-400	0-80	50M	100FT	20FA	
4	0-240	0-600	0-120	100M	200FT	50FA	
5	0-320	0-1000	0-160	100M	200FT	50FA	

5. Off Center

Four-position selected by TRAIN knob in expanded sonar mode.

Two-position selected by TILT knob in vertical fan mode.

6. Numeric Information and Display Scale/Mark

Training Data Range, Tilt angle
Trackball Data Slant, Horizontal range, depth, Bearing

R/B Mark Data Range, Bearing

Scale/Marker Bearing scale, Sector center mark, Own ship's mark, Trackball and Event markers

Latitude/longitude, courseline and north mark are displayed when nav sensor is connected.

7. Audio Monitor

Output 4W, 4Ω using external speaker CA-150 (option)

Frequency 900/1000Hz selected by internal settings

8. Transceiver

Frequency: 60 or 162kHz

Output Power and Beamwidth

(1) Sonar Mode

Freq.	Output* Power	Beamwidth at -3dB				
		TX		RX		
		Hor.	Vert.	Hor.	Vert.	
60kHz	1.0kW	60° (FAST TRAIN "ON")	16°**	13°	16°	13°
162kHz	1.5kW		9°**	6°	8°	6°

*: Output power can be reduced in three steps.

**: Fast Train mode "OFF"

(2) Vertical Fan Mode

Freq.	Output* Power	Beamwidth at -3dB			
		TX		RX	
		Hor.**	Vert.	Hor.*	Vert.
60kHz	1.0kW	16°	13°	16°	13°
162kHz	1.5kW	9°	6°	8°	6°

*: Output power can be reduced in three steps.

**: 30° approx. when selecting "WIDE" beamwidth on the menu.

Pulselength: 0.2 to 10.6ms, fixed or varied according to the range in use (selectable on the Menu)

9. Training

Mode	Sonar (horizontal) mode	Vertical Fan mode
Train Step	45° or 6° step	Auto Train: 15° step Manual: 6° step
Auto Train Sector	–	90°, 180° or 360°
Manual Train Sector	–	Half (174°) or Full (360°)

10. Tilting

Mode	Sonar (horizontal) mode	Vertical Fan mode
Tilt Range	+5° to 90°	0° to +180°
Tilt Step	1°/step	6° or 3°/step
Stabilizer (option)	Motion sensor MS-100 stabilizes sounding beam against rolling and pitching of up to ±20°.	

11. Transducer Raise/Lower

Transducer travel: 400mm
Raise time: approximately 10 sec (24/32Vdc)
Lower time: approximately 8 sec (24/32Vdc)

12. Allowable Ship's Speed

18 knots (15 knots during raise/lower operation)

13. Power Supply and Consumption

24/32VDC, 200W (300W during transducer raise/lower)
100/110/200/220VAC, 50/60Hz with two sets of rectifiers
RU-1746B-2

14. Ambient Condition

Temperature: 0°C to 50°C
Humidity: less than 95%

COMPLETE SET







STANDARD SUPPLY

No.	Name	Type	Code No.	Qty	Weight (kg)	Remarks
1	Display Unit	CH-360-E	000-068-412	1	20	14" CRT
2	Transceiver Unit	CH-341-60 CH-341-162	000-068-414 000-068-417	1	8.5	60kHz 162kHz
3	Hull Unit	CH-342		1	55	Specify the power supply voltage, frequency and main shaft length when ordering.
4	Accessories	FP02-03200	000-014-745	1		
5	Installation Materials	CP06-00800 CP06-00810 CP06-00820	000-068-443 000-068-444 000-068-445	1		With 15m cable (STD) With 30m cable With 50m cable
6	Spare Parts	SP06-00800	000-068-442	1		

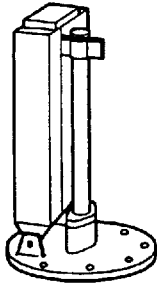
OPTION

No.	Name	Type	Code No.	Weight (kg)	Remarks
1	Motion Sensor	MS-100	000-069-256	2	
2	Remote Control	CH-343-E	000-068-449	0.4	
3	Rectifier	RU-1746B-2	000-030-439 000-030-440	17	For 110VAC For 220VAC
4	Retraction Tank	06-007-1570(steel) SHJ-0001(steel) 06-007-1571(steel) SHJ-0022(FRP) 06-007-1573(FRP)	600-715-700 661-000-010 600-715-710 661-000-220 600-715-730		For 1.1m shaft For 2.2m shaft For 3.5m shaft For 1.1m shaft For 2.2m shaft
5	Interface	CH-344	000-068-447		For connection of external equipment.
6	E/S Interface	VI-1100A	000-021-803	2	
7	External Speaker	CA-150	000-109-070		
8	Handle	OP03-70	008-423-420		

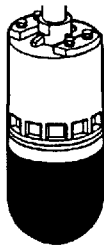
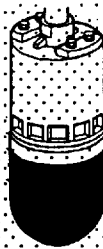
HULL UNIT ASSEMBLY COMBINATION

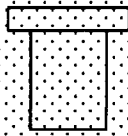
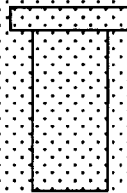
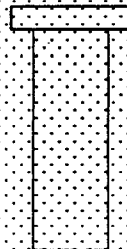
R / L D R I V E U N I T			<table border="1"> <thead> <tr> <th>Power</th> <th>Freq.</th> <th>Type</th> <th colspan="2">Code No.</th> </tr> </thead> <tbody> <tr> <td rowspan="2">DC24V</td> <td>60kHz</td> <td>CH-3421-60-2</td> <td colspan="2">006-547-010</td> </tr> <tr> <td>162kHz</td> <td>CH-3421-162-2</td> <td colspan="2">006-547-070</td> </tr> <tr> <td rowspan="2">DC32V</td> <td>60kHz</td> <td>CH-3421-60-3</td> <td colspan="2">006-547-020</td> </tr> <tr> <td>162kHz</td> <td>CH-3421-162-3</td> <td colspan="2">006-547-080</td> </tr> </tbody> </table>				Power	Freq.	Type	Code No.		DC24V	60kHz	CH-3421-60-2	006-547-010		162kHz	CH-3421-162-2	006-547-070		DC32V	60kHz	CH-3421-60-3	006-547-020		162kHz	CH-3421-162-3	006-547-080	
	Power	Freq.	Type	Code No.																									
DC24V	60kHz	CH-3421-60-2	006-547-010																										
	162kHz	CH-3421-162-2	006-547-070																										
DC32V	60kHz	CH-3421-60-3	006-547-020																										
	162kHz	CH-3421-162-3	006-547-080																										
S H A F T	STANDARD		OPTION																										
	 1.17m		 2.2m		 3.8m																								
	Type	Code No.	Type	Code No.	Type	Code No.																							
06-008-1021	100-028-500	SHJ-0006-1	661-000-061	06-007-1572	600-715-720																								
S O U N D O M E	2.7m Cable		3.7m Cable		5.3m Cable																								
																													
	Power	Freq.	Type	Code No.	Power	Freq.	Type	Code No.	Power	Freq.	Type	Code No.																	
DC24V	60	CH-3422-60-11	006-547-090	DC24V	60	CH-3422-60-22	006-547-100	DC24V	60	CH-3422-60-38	006-547-110																		
DC32V	162	CH-3422-162-11	006-547-180	DC32V	162	CH-3422-162-22	006-547-190	DC32V	162	CH-3422-162-38	006-547-200																		
T A N K	 1m		 1.8m		 3.5m																								
	Type	Code No.	Type	Code No.	Type	Code No.																							
	IRON	06-007-1570	600-715-700	IRON	SHJ-0001-0	661-000-010	IRON	06-007-1571	600-715-710																				
	FRP	SHJ-0022	661-000-220	FRP	D6-007-1573	600-715-730																							
ALUM	10-044-2601	100-127-500																											

APPENDIX

A. CHANGING SPECIFICATIONS

According to user requirements, and in order to render use even easier, the operating specifications can be changed to those shown in the tables which follows.

Changing DIP Switch Setting

The DIP switch used to change the specifications is on the MTR board in the display unit. Change settings to fit user's particular requirements.

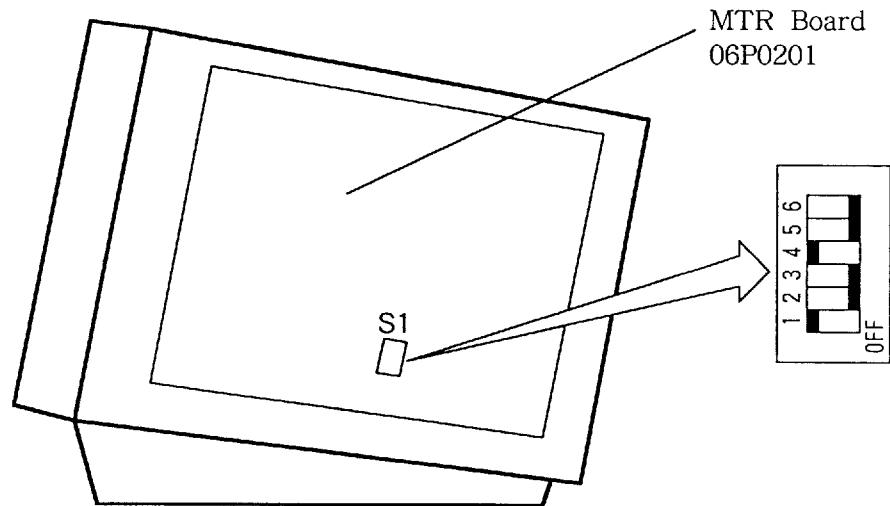

No.	Items	Settings and Description			
1	Input Signal	ON	Echo Signal	OFF	Test Signal
		OFF		ON	
3	Echo Dynamic Range	ON	Wide	OFF	Narrow
		Choose "wide" for better sensitivity of weak echoes.			
4	Echo Smoothing	ON	Smoothing on	OFF	Smoothing off
		Echo smoothing stretches echoes in distance direction.			

The settings appearing in shading in the table above indicates factory settings.

B. SYSTEM MEMU SETTING

Procedure

1. While pressing and holding the MENU key turn on the power. Release the key when you hear a beep. The system menu appears after the initial check results.
2. Select item with keys and set parameter with keys.
3. To escape, turn off the unit.

SYSTEM MENU			
POSITION DISPLAY	: OFF	<input checked="" type="checkbox"/> L/L	LOP
DEPTH DISPLAY	: OFF	<input type="checkbox"/> ON	
HEADING DISPLAY	: OFF	<input type="checkbox"/> TRUE	AZ
NORTH MARK	: OFF	<input type="checkbox"/> ON	
TRACK	: <input type="checkbox"/> 10R	20R	
HDG/SPD DATA	: <input type="checkbox"/> GYRO/LOG	CI	NAV
LOG PULSE	: <input type="checkbox"/> 200	400	
NAV DATA	: <input type="checkbox"/> GPS	LORAN C	LORAN A
	DR	DECCA	OTHERS
DATA FORMAT	: <input type="checkbox"/> CIF	NMEA	
NAV BAUD RATE	: 1200	2400	<input type="checkbox"/> 4800
CI BAUD RATE	: 1200	2400	<input type="checkbox"/> 4800
TVG CORRECTION	: <input type="checkbox"/> OFF	1/2	1
UNIT	: <input type="checkbox"/> M	FT	FA HIRO
V-MODE MANUAL TRAIN	: <input type="checkbox"/> HALF	FULL	
言語/LANGUAGE	: 和文	<input type="checkbox"/> ENGLISH	
BACKUP CLEAR	: <input type="checkbox"/> NO	YES	

Description of System Menu

Item	Parameter	Description
Position Display	OFF L/L LOP	Selection of ship's position display L/L ----- Latitude/Longitude LOP ----- Line Of Position of Loran system
Depth Display	OFF ON	On and off of depth data fed from color video sounder
Heading Display	OFF TRUE AZ	Selection of heading display True: True bearing AZ: 16° azimuth bearing
North Mark	OFF ON	On and off of north mark
Track	10R 20R	Selection of length of ship's courseline plotting 10R: Ten times the range in use 20R: Twenty times the range in use
Heading Data	GYRO NAV	Selection of data used for ship's courseline plotting Gyro: Data from gyrocompass and speed log NAV: Data from navigation equipment
Log Pulse	200 400	Setting pulses-per-mile (pps) specifications of speed log 200 ---- 200pps 400 ---- 400pps
Nav Data	GPS LORAN C LORAN A DR DECCA OTHERS	Selection of source for ship's position display. NOTE: For sat-nav combined with Loran A or Loran C in FURUNO CIF data format, select Loran A or Loran C.
Data Format	CIF NMEA	Selection of input and output data format
Baud Rate	1200 2400 4800	Selection of baud rate of the data output
TVG Correction	Off 1/2 1	Changing TVG curve to compensate for absorption attenuation of ultrasonic wave in water
		OFF: Absorption attenuation neglected
		1/2: 1/2 of theoretical absorption attenuation value added to TVG curve
		1: Full theoretical absorption attenuation value added to TVG curve
Unit	M FT FA HIRO	Unit selection
Language	ENGLISH	Selection of language used for self check and error message on the screen.
Backup Clear	NO YES	On and off of the backup clear. When "YES" is selected, the current settings are cleared and the equipment starts with the factory-settings.

C. E/S MENU SETTING

When an external echo sounder is connected through the interface unit, the E/S (Echo Sounder) menu becomes available. Select the items and set parameters following the procedures below.





- Operating Procedure**
- (1) Press the MENU key on the Sub-panel 2.
 - (2) Select the E/S menu.
 - (3) Select item with the horizontal arrow key and set parameters with the vertical arrow key. The selected item is highlighted and the current setting is circumscribed in white.
 - (4) To turn off the menu, press the menu key again.

MENU	:	SONAR	BOTTOM/3D	<u>E/S</u>
RANGE	:	<u>40</u>	80	160
		240	320	
SHIFT	:	0		
<u>GAIN</u>	:	6.0		
N. L	:	6.0		
IR	:	0		
NET SONDE	:	<u>OFF</u>	ON	
ADVANCE	:	<u>OFF</u>	ON	
SPEED	:	<u>1/1</u>	1/2	1/4
RES. COLOR	:	<u>LOG</u>	LINEAR	
EXIT	:	PRESS MENU KEY.		

Contents of E/S Mode

Menu Item	Meaning
RANGE	Selects the display range for echo sounder picture.
SHIFT	Changes the start depth of the display.
GAIN	Adjusts the sensitivity of echoes.
NL	Rejects noise which appears on the screen in light blue or blue. "1" - "2" is the normal setting.
IR	When interference from other echo sounders operating nearby or other electrical noise can be seen on the screen, select ON to reduce or eliminate the interference.
NET SONDE	Turns the sonde mark display on and off.
ADVANCE SPEED	Selects the picture advancing speed. 1/1 is the fastest.
RES. COLOR	This menu sets the echo presentation characteristics. LOG enhances weak echo and is normally used. LINEAR downplays the weak echoes comparing with LOG. It is effective to suppress the plankton layer.

D. LIST OF SPECIAL KEY OPERATION

Key Operation	Function
 + Power "ON"	Displaying system menu screen. See AP-2.
 + Power "ON"	Displaying self-check screen. See page 6-1.
 + Power "ON"	Starting CH-36 without connecting hull and transceiver units.
 + Power "ON"	For the service technician. Current setting data of GAIN, FREQUENCY, TVG, PITCHING, ROLLING and NL appear on the center bottom of the screen.

■ **NOTE:**
Keep pressing each key until you have a beep.

E. MEMO-PAD FOR CUSTOM KEY

(Front)

(Back)

FISHING GROUND		

MODE		MODE		MODE	
RANGE	200m	RANGE	200m	RANGE	100m
SECTOR	225°	SECTOR	360°	SECTOR	180°
TRAIN	0°	TRAIN	0°	TRAIN	
TILT	30°	TILT	30°	TILT	

FISHING GROUND		
MODE RANGE SECTOR TRAIN TILT	MODE RANGE SECTOR TRAIN TILT	MODE RANGE SECTOR TRAIN TILT

← Cut out the memo-pad by a cutter and insert it to the label case after folding it in two.

Fold here

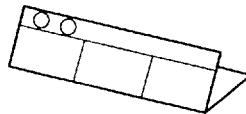

FISHING GROUND		
MODE RANGE SECTOR TRAIN TILT	MODE RANGE SECTOR TRAIN TILT	MODE RANGE SECTOR TRAIN TILT

FISHING GROUND		
MODE RANGE SECTOR TRAIN TILT	MODE RANGE SECTOR TRAIN TILT	MODE RANGE SECTOR TRAIN TILT

FISHING GROUND		
MODE RANGE SECTOR TRAIN TILT	MODE RANGE SECTOR TRAIN TILT	MODE RANGE SECTOR TRAIN TILT

FISHING GROUND		
MODE RANGE SECTOR TRAIN TILT	MODE RANGE SECTOR TRAIN TILT	MODE RANGE SECTOR TRAIN TILT

FISHING GROUND		
MODE RANGE SECTOR TRAIN TILT	MODE RANGE SECTOR TRAIN TILT	MODE RANGE SECTOR TRAIN TILT

FISHING GROUND		
MODE RANGE SECTOR TRAIN TILT	MODE RANGE SECTOR TRAIN TILT	MODE RANGE SECTOR TRAIN TILT

FISHING GROUND		
MODE RANGE SECTOR TRAIN TILT	MODE RANGE SECTOR TRAIN TILT	MODE RANGE SECTOR TRAIN TILT

FISHING GROUND		
MODE RANGE SECTOR TRAIN TILT	MODE RANGE SECTOR TRAIN TILT	MODE RANGE SECTOR TRAIN TILT

F. CHARACTERISTICS OF THE ULTRASONIC WAVE IN WATER

The purpose of this chapter is to provide an overview of the characteristics of the ultrasonic wave in water.

Sound Velocity It is generally known that an ultrasonic wave travels 1500 meters per second in sea water, but in practice, some amount of variation arises depending on the season and area from differences in the following three factors:

Water temperature θ [C]
 Salinity density S [%]
 Water pressure (water depth) h [m]

Therefore, for propagation in surface water the velocity changes not only by area but also by direction of the wave propagation. The equation obtained thru numerous measurements is;

$$C = 1410 + 4.21\theta - 0.037\theta^2 + 1.145S + 0.0168h \text{ [m/s]}$$

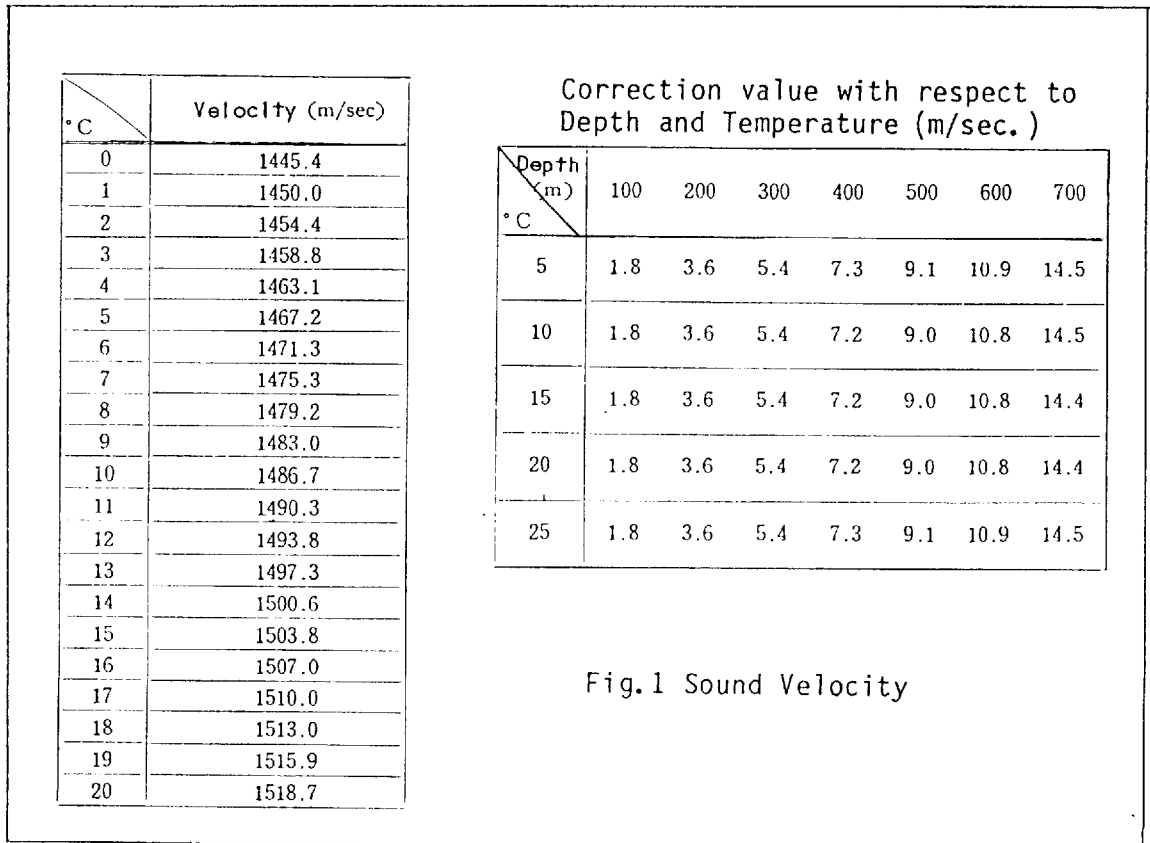

Fig.1 Sound Velocity

Research in the waters throughout the world has revealed that there is a difference of approximately 100[m/s] between the areas where the velocity is maximum and minimum.

Generally, the velocity increases as follows, provided that salinity density is constant:

- 3m/sec for every 1 degree rise of water temperature.
- 1.7m/sec for every 100m increase of water depth.

Absorption and Attenuation

An ultrasonic wave emitted into water becomes weaker in intensity as it goes away from the emitting source. Principle causes of attenuation are:

1. Acoustic energy of the ultrasonic wave decreases gradually through reflection, refraction and diffusion in water.
2. Acoustic energy is absorbed by the viscosity of the medium (water) and converted into other forms of energy.

The higher the frequency, the greater the absorption and attenuation of the ultrasonic wave as shown below. In other words, the absorption coefficient is a function of the frequency. Generally, total energy loss encountered on the way to and from a target is expressed

$$TL [dB] = 40\log R + 2\alpha R$$

where R ----- Range to a target
 α ----- Absorption coefficient

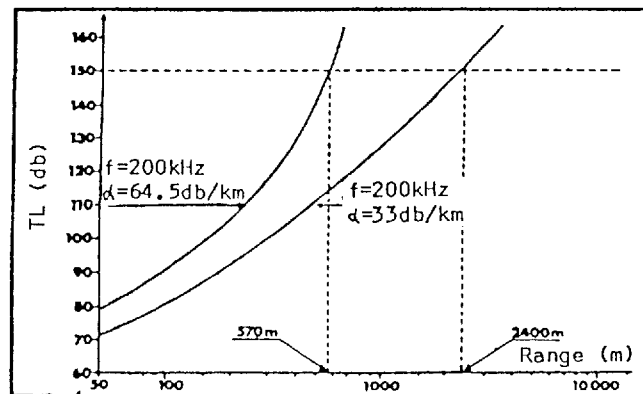
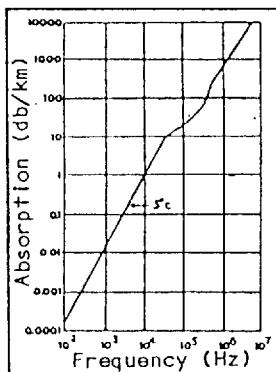

Refraction

An ultrasonic wave transmitted in water does not travel straight but is more or less refracted. This refraction is caused by the variation of propagation velocity in water. If the velocity decreases (temperature decreases) with depth, the top part of the wave front moves faster than its bottom part, and gradually the front bends downwards. In the same way, it bends upwards if the sound velocity increases (temperature rises) with depth.

In other words, the ultrasonic wave refracts toward colder water.

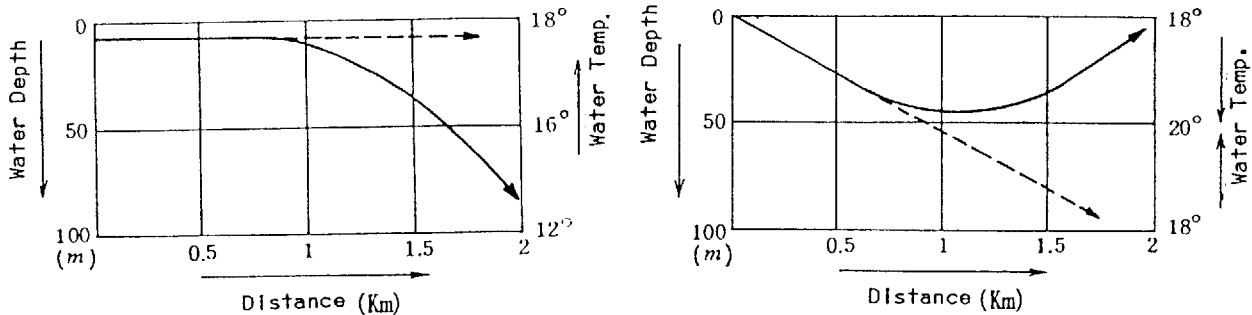

Here, a fishing ground off Hokkaido island in Japan is taken as an example.

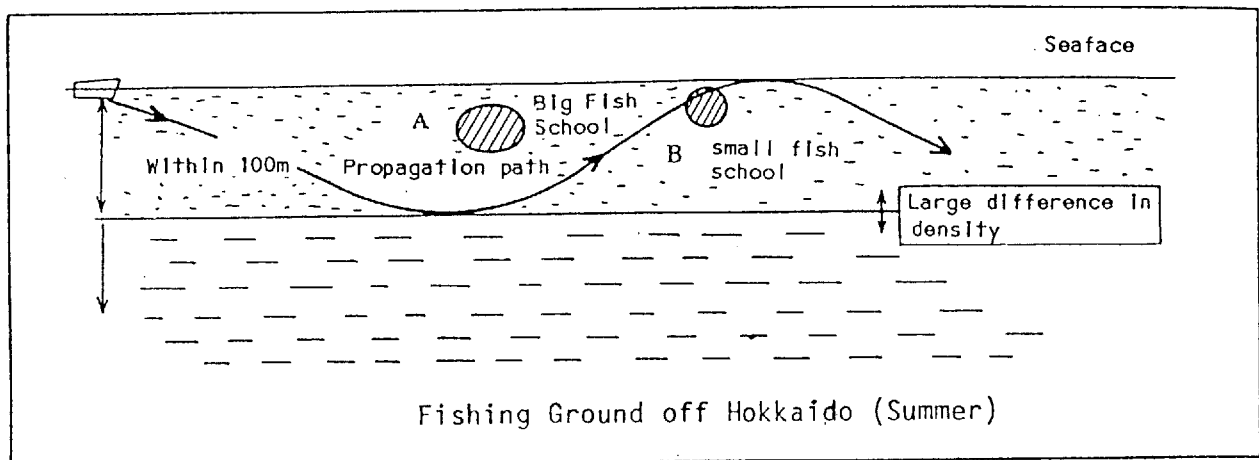

In summer, there is a large difference in salinity density below and above the 100m deep point. An ultrasonic wave emitted almost in the horizontal direction propagates within 100m deep water in the same way as a radio wave in a waveguide. As a result, even a small fish school is sometimes detected at an unexpected long range or on the contrary, detection of a large fish school does not extend to a relatively long range. These phenomena are encountered when two fish schools lie in positions "A" and "B" of the illustration.

The drawing below shows how temperature variation affects sound propagation with respect to different emitting directions (tilt angles).

Beams tilted five and ten degrees bend upward at 400m and 600m points respectively. Beams tilted down more than 15 degrees travel in almost straight lines. Between the two beams, a blind zone is created beyond the 600m point. In this zone nothing can be detected. The shown drawing is only an example calculated by a computer, based on the temperature with depth as shown in the left column of the figure. In actual fishing grounds, the temperature distribution and subsequently the behavior of the sound beam is much more complicated. It is, therefore, for effective use of sonar, necessary to know at least roughly how the temperature is distributed in various waters.

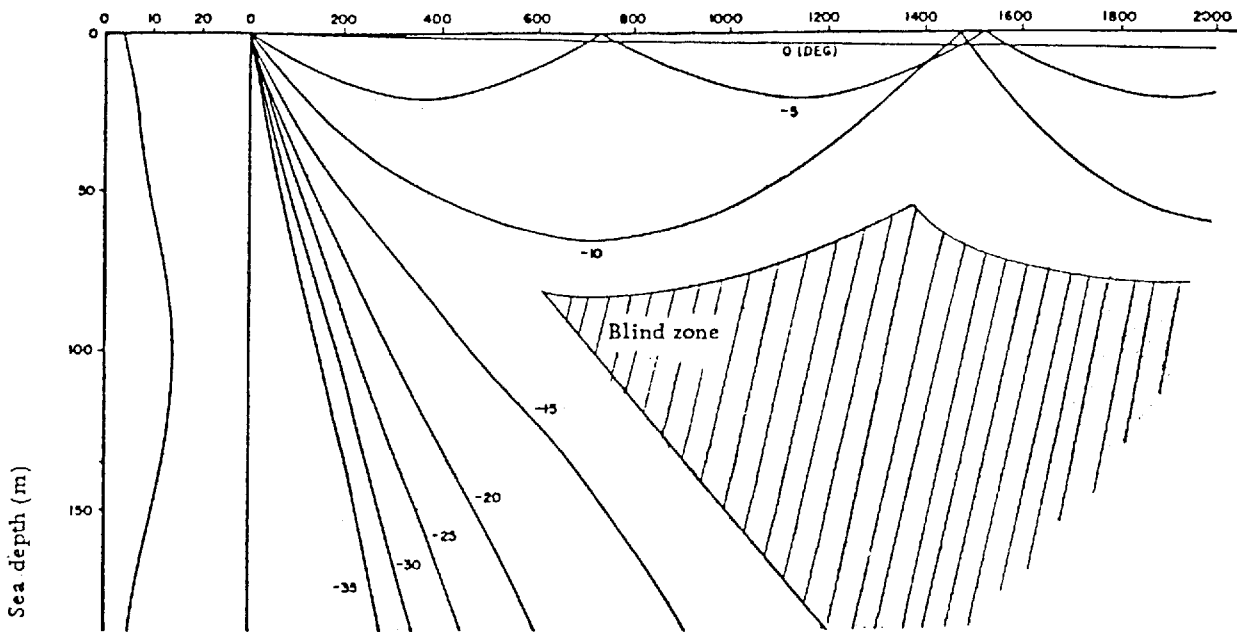

Adverse Effect of Air Bubbles

Even infinitesimal air bubbles in sea water (liquid medium) affect propagation of ultrasonic sound. This is because the cubic elasticity of gas is extremely small when compared with that of liquid; the air bubbles violently vibrate (contract and expand) by the action of sound pressure, diffusing the ultrasonic wave and dispersing part of the acoustic energy. In a liquid which contains a large amount of air bubbles, attenuation of an ultrasonic wave increases and the wave is reflected at the boundary of waters which contain and do not contain air bubbles.

From the above it can be said that reflection occurs in the boundary where the density (P) of the material (medium) that is, the velocity of the ultrasonic wave changes. The velocity of an ultrasonic wave with respect to its medium is 200 thru 400m/s in gas, except for hydrogen and helium; 900 thru 2000m/s in liquid (several times higher than in air) and 2000 thru 6400m/s in ordinary metal.

The product of the density (P) and the velocity (C) is called intrinsic acoustic impedance and in the boundary between two media which has extremely different C from each other, most of the acoustic power is reflected and only a small portion penetrates. (In the boundary between water and air, the acoustic energy penetrates with a loss of approximately 30dB, that is approximately 0.1% of the energy penetrates from one medium to the other.)

Reflection from water which contains air bubbles is caused by the fact that the cubic elasticity decreases in aerated water, causing the intrinsic acoustic impedance to change.

In the actual sonar operation, adverse effect of air bubbles is shown by interrupted display of target echoes which occurs while crossing over the wake of another boat or when the sonar transducer passes above the air bubbles generated by own ship.

Air bubbles in water have a resonant frequency of 15kHz thru 100kHz and hence the ultrasonic wave in this frequency range is most strongly affected.

Reflection at Seabed and Fish School

The nature of the seabed is roughly classified into the following four kinds: crag, sand, mud and seaweeds. In addition, shells and carcass of animals (especially coral) imbedded in the seabed cause reflection loss.

$$\text{Reflection Loss } L_b = 20 \log \frac{\text{Incident sound pressure}}{\text{Reflection sound pressure}} \quad (\text{db})$$

The actual reflection loss in the sea is shown below. The reflection loss remains almost constant up to 50kHz and then gradually increases.

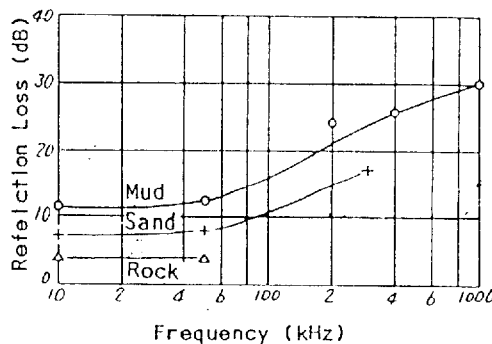

The relation of frequency vs reflection loss for mackerel is shown below. The calculated value and actually measured value nearly coincide. And also, on the contrary to the seabed reflection, the reflection loss decreases as the frequency increases. The "K" in the figure is the coefficient of fish shape, where its larger value introduces smaller reflection loss.

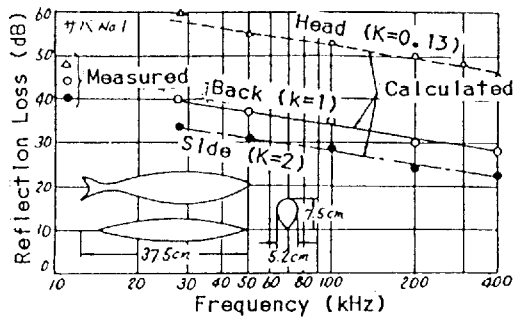

Reflection Loss
(Mackerel No. 1)

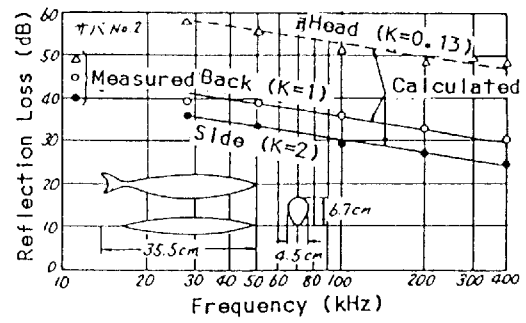

Reflection Loss
(Mackerel No. 2)

Species	Incident Direction of Ultrasonic Wave		
	Back	Side	Head
Sardine	1	2	0.13
Bonito	1	2	0.5
Horse Mackerel	0.8-1.2	1.4-2.2	0.4-0.6
Sea Bream	0.9	3	0.45
Turbot		2	
Average	1	2	0.4