

Estimated Effort to Release Load

The estimated effort to pull on the Sea Catch release line to release capacity load is as follows:

<u>Model</u>	<u>SWL</u>	<u>Effort to release</u>
TR3	.65 tons	8 lbs / 3.62 kgs
TR5	1.66 tons	30 lbs / 13.6 kgs
TR7	3.52 tons	40 lbs / 18 kgs
TR8	4.78 tons	88 lbs / 40 kgs
TR10	7.92 tons	145 lbs / 65 kgs
TR11*	14.08 tons	258 lbs / 117 kgs
TR12*	16.42 tons	301 lbs / 136 kgs
TR15*	25.10 tons	460 lbs / 208 kgs
TR16*	31.68 tons	580 lbs / 263 kgs
TR17*	47.37 tons	867 lbs / 394 kgs
TR18*	77.11 tons	1411 lbs / 640 kgs

*Alternative release methods shown on page 6.

Product Disclaimer

The specifications information and performance of the products manufactured by McMillan Design (MD) and featured in this publication may be changed without notice. This web version of the User's Manual takes precedence over other versions. While MD does everything within its control to ensure all its products have an appealing appearance free of defects and surface deformations, some cosmetic irregularities may be present but do not impair the integrity, function or performance of the product. Since the use of this information and the conditions by which the products are used are beyond the control of MD, it is the obligation of the owner and/or the equipment operator to carefully read and understand the Sea Catch User's Manual and determine the correct and safe selection and settings and conditions of use of the equipment and products. While components manufactured by others such as hydraulic or air cylinders, squibs or cartridges that are fitted to MD products are selected for optimum function, durability and appearance, MD is not responsible for loss or damage caused by their malfunction or part failure, while operating the device in or out of water. MD is not responsible for damages to persons or property caused by loads such as dynamic loads, hydrodynamic loads and/or inertial loads that cause the overall load to exceed the safe working load (SWL) of that product, damages to persons or property caused by failure of a product that has been welded, or otherwise altered by the product's owner. To the extent that the law permits, any liability which may be incurred as a result of the use or future use of a product manufactured or sold by MD is limited to the cost of repairing or replacing the failed product or component at the discretion of MD, either within, or outside of warranty periods, and does not extend to any loss or damage which may be caused as a consequence of misuse or failure of the equipment or products. MD, its owner(s), its shareholder(s), or its agents shall not in any event be liable for economic loss of profits, indirect, special, bodily injuries or consequential damages. By virtue of taking possession of any product manufactured by MD, the owner and/or the equipment operator agrees to the terms of this Disclaimer.

©Copyright 2015 McMillan Design, Inc.

All rights reserved by McMillan Design, Inc.

May not be copied in whole or part.

Sea Catch® is a registered trademark of McMillan Design, Inc.

Sea Catch is protected under US Pat. No. 5901990.

See your dealer or contact:

McMillan Design, Inc.

9816 Jacobsen Lane

Gig Harbor, WA 98332 USA

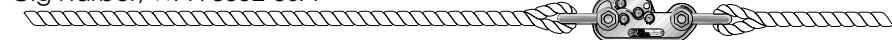

Tel: 253-858-1985 Fax: 253-858-1986

Website: WWW.SEACATCH.COM

SEA CATCH®

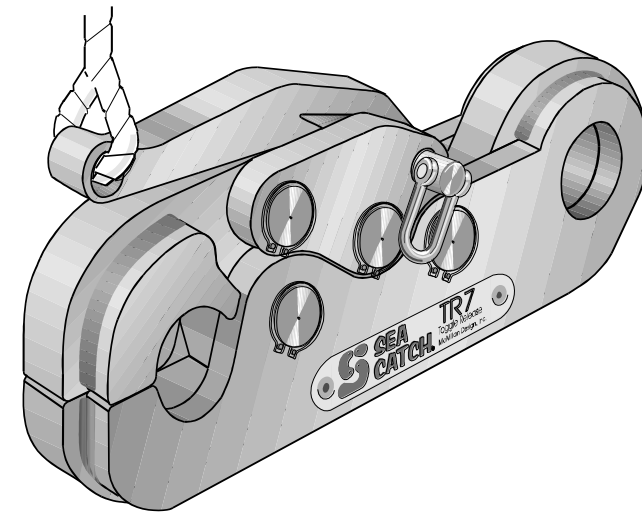

Sea Catch

User's Manual

Before operating the Sea Catch device, please carefully read and understand this document for your safety and the safety of others.

Sea Catch: General Specifications

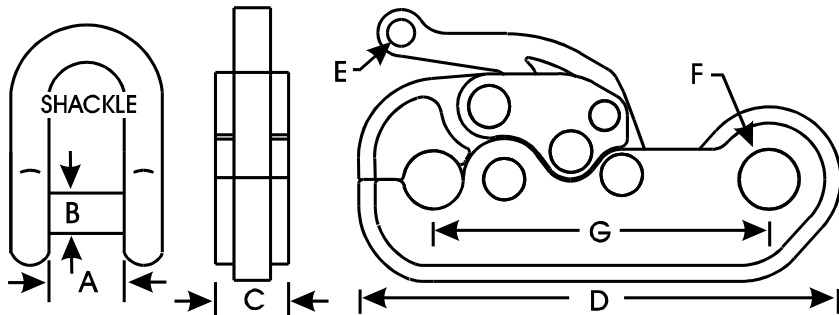

Mod.	Shackle Size (in)	A in(mm)	B	C	D	E	F	G	SW Load lb (sh ton)	Break Ld. lb (sh ton)	Weight lb (kg)
TR3	1/4	.47 (11.93)	.31 (7.87)	.41 (10.41)	2.85 (73.39)	.18 (4.57)	.37 (9.39)	1.96 (49.78)	1,302 (.65)	6,510 (3.2)	.31 (.14)
TR5	7/16	.75 (19.05)	.50 (12.7)	.69 (17.52)	4.5 (114.3)	.25 (6.35)	.55 (13.97)	3.13 (79.50)	3,323 (1.6)	16,618 (8.3)	1.3 (.58)
TR7	5/8	1.06 (26.92)	.75 (19.05)	1 (25.40)	6.62 (168.14)	.38 (9.65)	.81 (20.57)	4.56 (115.82)	7,042 (3.52)	35,210 (17.6)	4 (1.81)
TR8	3/4	1.25 (31.75)	.87 (22.09)	1.19 (30.22)	7.68 (195.07)	.43 (10.92)	.93 (23.62)	5.53 (140.46)	9,574 (4.78)	47,870 (23.93)	6.3 (2.85)
TR10	1	1.69 (42.92)	1.13 (28.70)	1.63 (41.40)	9.75 (247.65)	.56 (14.22)	1.21 (30.73)	6.87 (174.49)	15,840 (7.92)	79,200 (39.6)	12.5 (5.67)
TR11	1-3/8	2.25 (57.15)	1.50 (38.1)	2.12 (53.84)	13.15 (334.01)	.75 (19.05)	1.63 (41.40)	9.15 (232.41)	28,000 (14)	140,000 (70)	32 (14.5)
TR12	1-1/2	2.38 (60.45)	1.62 (41.14)	2.25 (57.15)	14.25 (361.95)	.81 (20.57)	1.78 (45.21)	9.92 (251.96)	32,860 (16.43)	164,300 (82.15)	40 (18.14)
TR15	1-3/4	2.88 (73.15)	2 (50.8)	2.75 (69.85)	17.56 (446.02)	1 (25.4)	2.16 (54.86)	12.21 (310.13)	50,200 (25.1)	251,000 (125.5)	69 (31.29)
TR16	2	3.25 (82.55)	2.25 (57.15)	3.13 (79.5)	19.73 (501.14)	1.12 (28.44)	2.46 (62.48)	13.75 (349.25)	63,380 (31.69)	316,900 (158.45)	108 (48.98)
TR17	2-1/2	4.15 (104.90)	2.75 (69.85)	3.88 (98.55)	24.13 (612.90)	1.37 (34.79)	3.01 (76.45)	16.81 (426.97)	94,740 (47.37)	473,700 (236.85)	197 (89.35)
TR18	3	5 (127)	3.25 (82.55)	4.75 (120.65)	30.79 (782.06)	1.75 (44.45)	3.85 (97.79)	21.43 (544.32)	154,240 (77.12)	771,200 (385.6)	360 (163.2)

SWL (capacity) is a ratio of 5:1 to Breakload.

Products are constantly being improved. Designs, dimensions, capacities and weights are subject to variation.

General Sea Catch Features:

- Perpendicular or parallel release directions
- Hitch pin lock for device locking safety
- Computer generated parts precision-cut from aerospace grade stainless steel plate
- Low friction, low effort lanyard-style release for maximum user safety
- On Load / Off Load Releasing
- All parts 100% stainless steel
- No springs

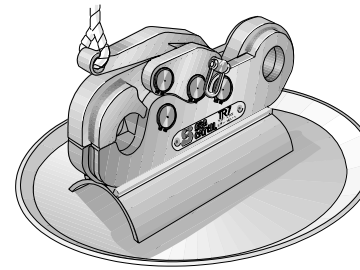

Sea Catch TR7S Skiff Release

A standard TR7 is securely mounted to a stainless steel dish. This stable base allows the unit to function dependably above seine gear during purse seine skiff release applications. Low kick-back, quiet operation, and a safe hitch pin securement are key elements for skiff release operations.

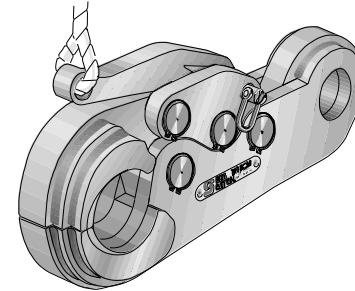

Sea Catch TR15LM

This is a modified TR15 provided with a front jaw enlarged to receive up to 3.4" fibre line. Additional side plates at the jaw area help spread the load and prevent line chafing. Other capacities are available.

Sea Catch RH Retrieving Hooks

These retrieving hooks are light weight and strong. Used with a pole spike, the hook is ideal for safe retrieval and recovery of loads at sea. A tag line holds the hook in the end of the pole and controls the load once the pole is removed.

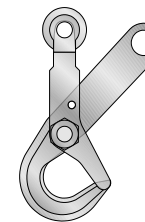
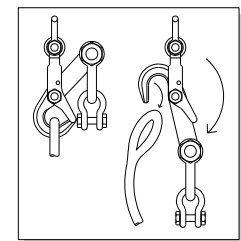
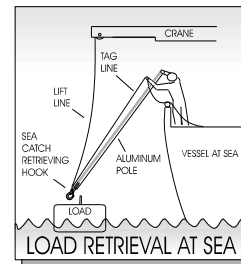

Sea Catch OLH25 Off-Load Hooks

This is a pivoting hook (SWL: 4.5 m tons) sized to receive up to 3" (7.62 cm) diameter line or strap. Counterweights can be shackles. The hook automatically rotates and releases the load line when load reaches seabed. Other sizes available.

Sea Catch Products

Sea Catch TR5SQ and TR7SQ squib-fired units

Standard TR5s and TR7s are fitted with a chamber to receive a squib or thruster. Electrically activated, these units are best suited for instant, or remote releasing applications. Manual back-up release is maintained with the lanyard pull.

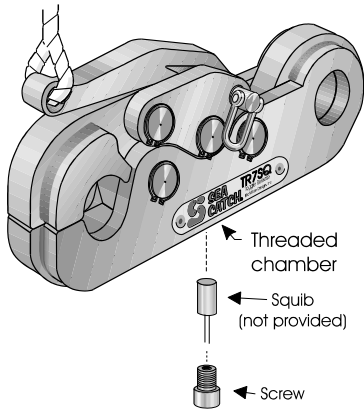

Sea Catch RAM units

Standard models may be fitted with hydraulic cylinders and fired hydraulically. Above the cylinder is a plunger which activates the release from below. Cylinders are rated at 5,000 psi and provide larger capacity units the necessary means for activation.

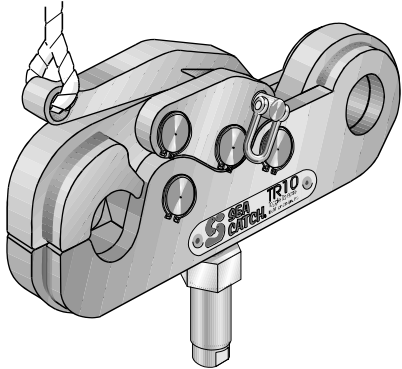

Sea Catch AIR units

Standard models may be fitted with air cylinders and fired with 100 psi shop air. Air cylinders are suitable for low capacity units and for applications where hydraulic ones are not suitable.

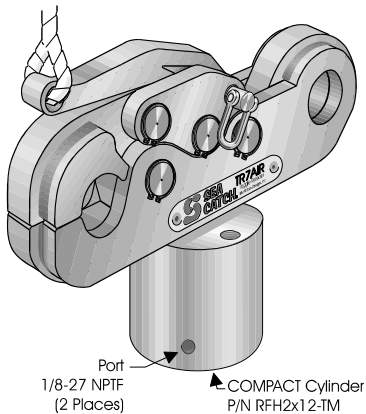

6

Sea Catch Operation

LOCKED:

5/8" Shackle →
 Aligned holes allows device locking with hitch-pin.
 Snap lever closed (over-center) to lock.
 Load

RELEASED:

To release remove hitch-pin and pull lanyard in either direction.
 Load

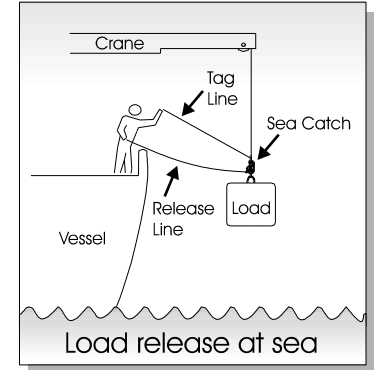
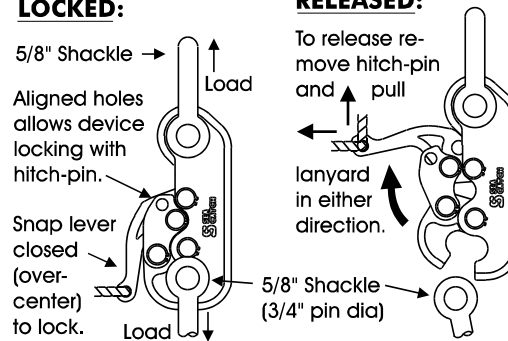

Operation: **Device Locking**

Having secured the recommended shackle to the rear end of the Sea Catch, open the jaw by removing the hitch pin and prying up the release lever and opening it to the released position. Insert the pin of the shackle to be released into the jaw opening.

Secure the shackle by closing the release lever to the locked position and firmly lock the toggle pin over center with a vice-grip-like snap.

The shackle is now held firmly locked even with no load on the device. The hitch pin can be reinserted to prevent inadvertent release.

The Sea Catch is now ready to be loaded. Once the hitch pin is removed, the Sea Catch is armed and ready to be released.

Device Releasing

Release of the loaded Sea Catch is activated by first removing the hitch pin and then pulling firmly on a release line connected to the end of the release lever. The release line can be activated in any direction within the 90 degrees perpendicular and parallel to the line of load. The Sea Catch can be released with or without load on the unit.

The use of the hitch pin is not required to secure the device in the locked position. It is an added safety measure preventing inadvertent release. A hitch pin is provided with each unit.

3

!! Warnings !!

Before operating the Sea Catch device, please heed these warnings.

- Improper use and improper care of the Sea Catch device may cause injury.
- Hitch-pin must be used to prevent inadvertent release.
- On a fully loaded Sea Catch with the hitch-pin removed, do not use the release line as a tag line or put any tension on it until time to release. An additional tag line secured to the upper shackle (as illustrated on page 3) and kept taught at all times is highly recommended to maintain a slack release line and prevent load twisting.
- Stay clear of all objects released under load.
- Do not exceed load capacity of this device.
- Choose the proper size Sea Catch so that it is not loaded with or releasing more than its rated load.
- Do not side load the Sea Catch as it may cause loss of retainer rings and other parts or permanently damage the device.
- While in its loaded position, do not obstruct the Sea Catch so as to prevent its body being aligned straight with the line of load. Misalignment may prevent the movable jaw from releasing the connected member even with the device in the released position.
- Do not mount the Sea Catch such that the mounting fixture damages the unit while in use. This could cause loss of parts and unit malfunction.
- Alterations to the Sea Catch by way of cutting, welding, and/or grinding voids the unit load rating and product warranty.
- **The warnings stated in this web version of the User's Manual take precedence over other versions of the Sea Catch User's Manual.**

Maintenance

- Inspection of the Sea Catch device is advised after each use. Should the device be held in a static state under load, inspection should occur every 3-6 months depending on the severity of its corrosive environment. Ensure every retainer ring is free of corrosion, properly installed and securely seated in its groove. Corroded retainer rings are an early sign of improper care.
- While in use in heavy marine environments or stored for long periods, a quick fresh water rinse and a coating of WD40 or other suitable corrosion retardant is advised. Always store the device in its closed and locked position.
- Pivot pins may require periodic re-lubrication. AQUALUBE is recommended for general marine use. Higher capacity models such as the TR15 and up require a NLGI #2.5 grease with moly added such as the McMaster-Carr item #1335K45. Pivot pin diameters and lengths can vary, therefore each pin must be marked and returned to its original hole.
 - Should the device become "soft" (little or no effort to open or close it), it is unsafe to use and should be returned to McMillan Design for a \$50 refurbishment which includes surface cleaning, attending to any issue with function (cost of replacement parts are not included) and re-lubrication.

Additional User Tips

Sea Catch Hitch Pin Securement

To prevent the loss of the hitch pin, two methods of securing it to the release line are suggested:

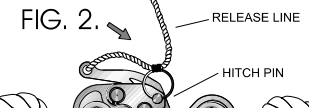
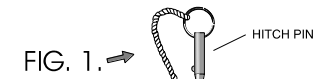

FIG. 1. The first option is to tie the hitch pin to the outer end of the release line.

FIG. 2. The second method is to secure the hitch pin at a point near the inner end of the release line as shown. This method not only provides hitch pin securement but may facilitate its removal at the time of release.

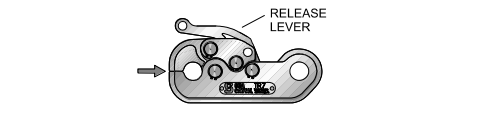

FIG. 3.

Sea Catch Over-Center Pressure

FIG. 3. Ample material has been left at the tip of the movable jaw (see arrow) where the jaw and body come in contact. This holds the device securely over-center in the locked position even when no load is applied to the device. It also helps prevent inadvertent release of the device.