

"BP" SERIES

WEIGHING BARS

Installation and user instructions

Ver. 10.06

INDEX

IMPORTANT WARNINGS	3
1. INTRODUCTION	3
1.1 MAIN TECHNICAL FEATURES.....	4
2. INSTALLATION	4
2.1 INSTALLATION OF BPSI, BPM, AND BPX BARS	4
2.2 INSTALLATION OF BPL BARS	6
2.3 EXAMPLE OF INSTALLATION.....	7
3. MAINTENANCE AND REPAIRS	8
3.1 TO OBTAIN THE BEST PERFORMANCES	8
3.2 DAMAGES AND OVERLOADS	8
4. TRANSPORT OF THE WEIGHING BARS	8
5. TABLE WITH CAPACITIES AND SIZES	8
6. DIMENSIONS AND PUNCTURE HOLE AREAS OF THE BPSI BARS	9
7. DIMENSIONS AND PUNCTURE HOLE AREAS OF THE BPM,BPX BARS	10
8. DIMENSIONS AND PUNCTURE HOLE AREAS FOR BPL BARS	11
9. EQUALISATION AND CALIBRATION INSTRUCTIONS OF A WEIGHING BAR SYSTEM (FIG.3)	12
10. SHIELDED CONNECTION CABLE BETWEEN THE JUNCTION BOX (JBOX) AND INDICATOR	13
WARRANTY	14



Do not solder, puncture or modify the structure without consulting the seller. Eventual damages or tamperings void the warranty conditions.

Do not tread, trample or expose the shielded connection cable to heat sources.

If material is weighed, whose manipulation can cause **electrostatic discharges** (powders, plastic materials, etc.). ONE MUST GROUND the metallic structure of the weighing bars using one of the fixing holes. If there are doubts consult the reseller.

If the place of use is a damp or wet environment, the installation must be made in order to **avoid accumulations or water stagnations and/or debris under the structure**.

DO NOT INSTALL IN A HAZARDOUS ENVIRONMENT.

(unless it is specifically provided for)

Do not use solvents for its cleaning.

1. INTRODUCTION

All the weighing modules are built with quality materials and with a calibration procedure which guarantees the maximum reliability and weighing precision in time.

The BP series' weighing bars are suitable for weighing rigid structures (hoppers, conveyor belts, roller units, pallets, tanks, cases, etc...), systems for weighing small, medium and large capacity objects; the weight capacities vary from a minimum of 15 kg up to 6000 kg.

The measuring elements are made of load cells made according to the standards required by the OIML R60 International Recommendation.

The **BPL** bars are fitted with 4 stainless steel SHEAR-BEAM load cells, resistant to dust and humidity according to IP68 norms.

The **BPSI**, **BPM** and **BPX** weighing bars are fitted with 2 aluminum OFF-CENTER load cells, resistant to dust and humidity according to IP67 norms.

All the modules are designed and built with a large load safety margin which guarantees its functioning also in particularly adverse conditions.

1.1 MAIN TECHNICAL FEATURES

- Functioning with 4 approved shear-beam load cells in IP68 stainless steel (BPL) and with 2 off-center approved load cells in aluminum (BPSI-BPM-BPX), according to the OIML R60 norms with protection from dust and humidity according to IP67 norms (350 Ohm input resistance)
- Structure made with profiles and oven-painted carbon steel plate and complete of fitted with articulated joints for compensating the bending and/or expansion of the structure to be weighed, and with stops for protection from accidental bumps.
- Screened 3m long 4-pin cable for connecting each bar with the fitted junction box.
- Up to 15 Vdc power supply.
- IP67 hermetic equalized junction box with screened 5m long 6-pin cable with connectors for connection to the indicator
- The STAINLESS STEEL model has the structure, mechanics, and trinkets in AISI304.

2. INSTALLATION

The accuracy of the weighing system depends on the following prerequisites:

- 1) Environment and mechanics appropriate for weighing: rigid, planar and exempt from vibrations
- 2) Weighing bars directly connected to the system (see the “EXAMPLE OF INSTALLATION” and “EQUALISATION AND CALIBRATION INSTRUCTIONS OF A WEIGHING BAR SYSTEM” chapter)
- 3) Barycentre of the loading and unloading system inside the bars and weighing made within the two bars
- 4) Time period of weight reading enough to stabilize it.

2.1 INSTALLATION OF BPSI, BPM, AND BPX BARS

NOTE: The weighing bars must be connected to the weight indicator through its cable coming from the junction box following the instructions in the indicator manual.

The electronic instruments connected to the weighing bars can not be calibrated before being powered. The customer is responsible for preparing and calibrating the instrument. For further details refer to the technical operating manual of the instrument.

A) After having removed the eventual packing, UNBLOCK THE WEIGHING BARS (only for BPM and BPX, while the BPS bars are not blocked) BY UNSCREWING AND REMOVING THE “A” SCREWS, REF. FIGURE 1.

B) Adjust the weighing bars so that these lie flat.

C) Connect the shielded cable coming from the junction box to the weight indicator, referring to the instructions of the indicator itself. The cable must be free and not provoke resistance so that it does not influence the measurement.

D) Carry out the equalization of the bars, see the relative paragraph.

E) Carry out the calibration and SetUp of the indicator as shown on its user manual.

F) If it will be moved again, remember to block the bars by screwing the A screws, figure 1.

G) RESPECT AND APPLY THE WARNINGS OF PAGE 2

BPM, BPX BARS

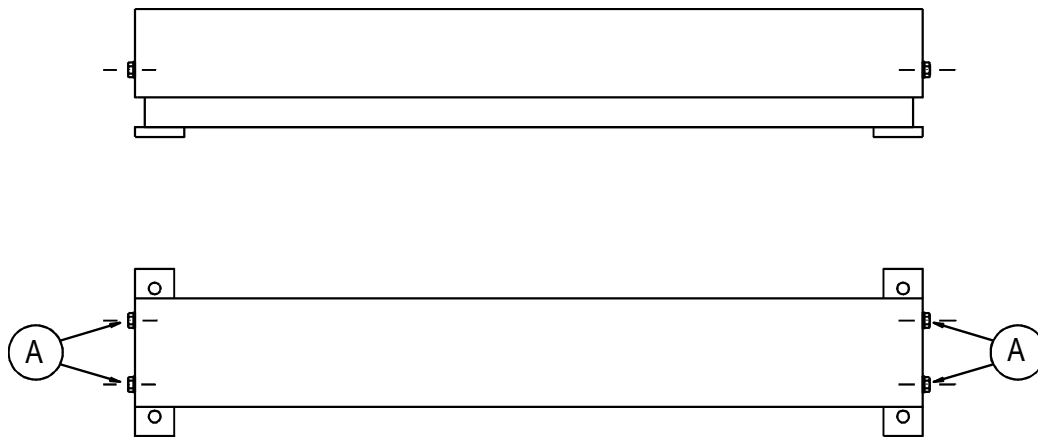

BLOCKED BAR

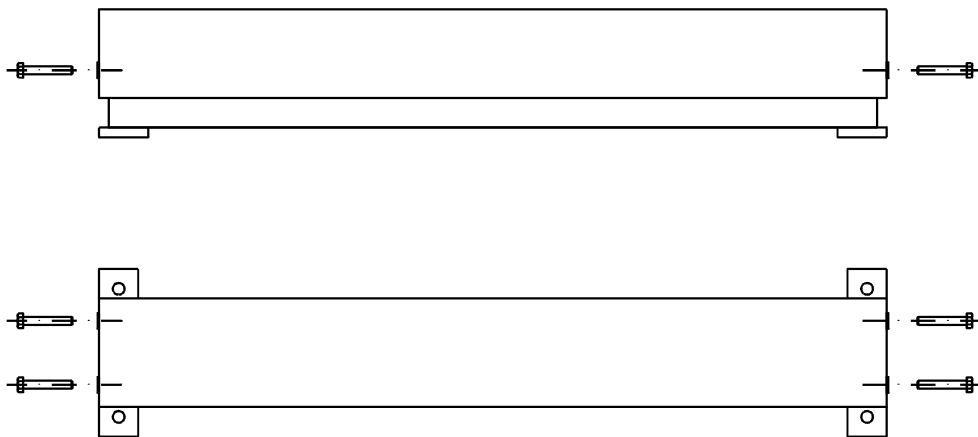

UNBLOCKED BAR

FIG.1

DIS. 819F34 14/03/02

2.2 INSTALLATION OF BPL BARS

NOTE: The weighing bars must be connected to the weight indicator through its cable coming from the junction box following the instructions in the indicator manual.

The electronic instruments connected to the weighing bars can not be calibrated before being powered. The customer is responsible for preparing and calibrating the instrument. For further details refer to the technical operating manual of the instrument.

A) After having removed the eventual packing, **UNBLOCK THE WEIGHING BARS BY UNSCREWING AND REMOVING THE SCREWS, REF. FIGURE 2.**

B) Do not remove for **ANY REASON** the bolts and the painted **RED** screws.

C) Adjust the weighing bars so that these lie flat.

D) Connect the shielded cable coming from the junction box to the weight indicator, referring to the instructions of the indicator itself. The cable must be free and not provoke resistance so that it does not influence the measurement.

E) Carry out the equalization of the bars, see the relative paragraph.

F) Carry out the calibration and SetUp of the indicator as shown on its user manual.

G) If it will be moved again, remember to block the bars by screwing the A screws, figure 1.

H) RESPECT AND APPLY THE WARNINGS OF PAGE 2

BPL BARS

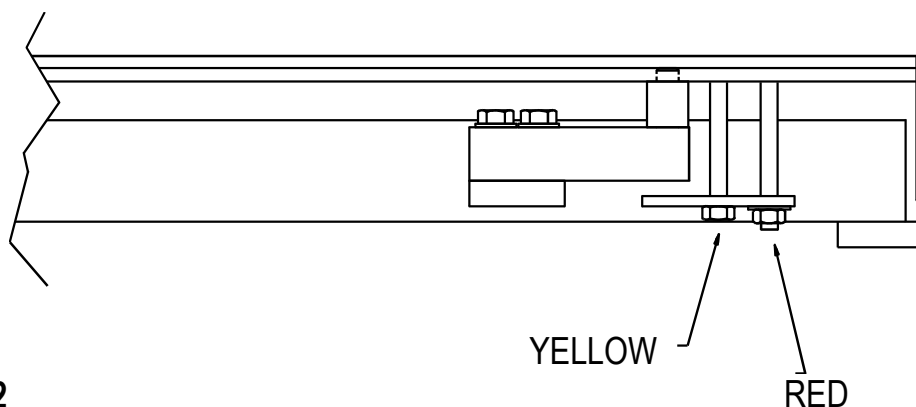

FIG.2

RED= SCREWS NOT TO BE MOVED OR ALTERED FOR ANY REASON

YELLOW= SCREW TO BE REMOVED IN ORDER TO UNBLOCK THE WEIGHING BAR

2.3 EXAMPLE OF INSTALLATION

CORRECT INSTALLATION:

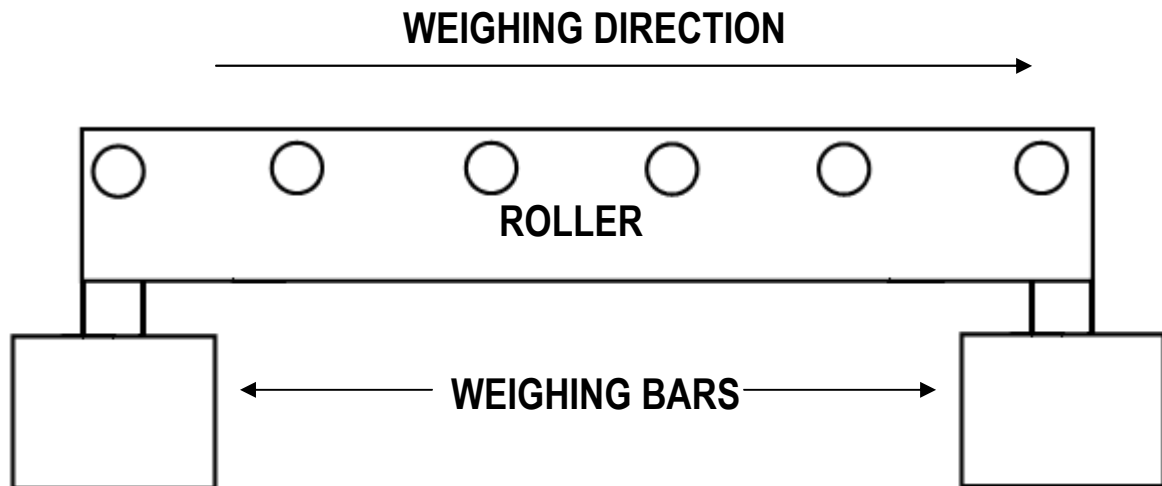

WRONG INSTALLATION:

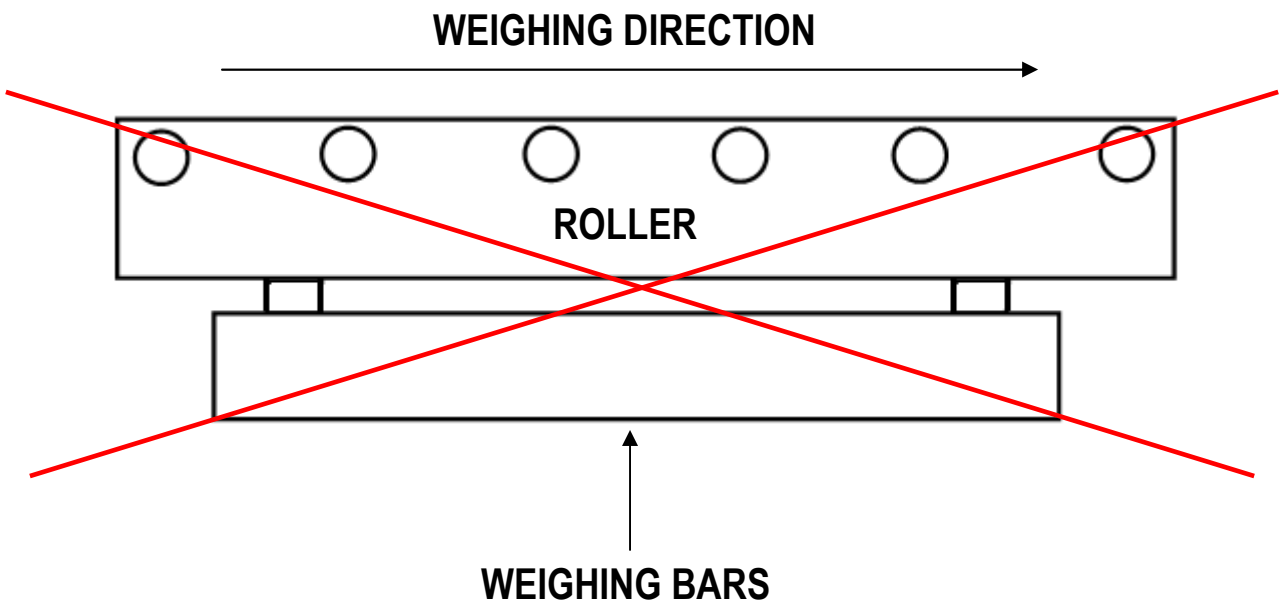

3. MAINTENANCE AND REPAIRS

3.1 TO OBTAIN THE BEST PERFORMANCES

- Keep the weighing bars clean. If dirt and powder accumulate on the weighing bars, clean them with a damp cloth or with the standard cleaning products (**do not use SOLVENTS and ACIDS**).
- Avoid that the weighing bars be subject to knocks, otherwise serious damages take place.

3.2 DAMAGES AND OVERLOADS

If you think that the weighing bars are broken or damaged, disconnect these in a permanent manner. Do this, if the weighing bars:

- show damage signs.
- cease to function.
- have been overloaded beyond the tolerable limits (for example during the transport, or while being stocked).

4. TRANSPORT OF THE WEIGHING BARS

To pack the weighing bars follow the procedures below:

- a) turn off the instrument.
- b) Disconnect the instrument from the weighing bars

5. TABLE WITH CAPACITIES AND SIZES

BAR MODELS	CAPACITY Max. kg	DIMENSIONS mm	
		HEIGHT	RESTING SURFACE
BPSI	15 / 30 / 60 / 150	85+20	400 x 80
BPM	60 / 150 / 300	130	600 x 105
BPX	150 / 300 / 600	130	800 x 135
BPL	600 / 1500 / 3000 / 6000	120	1200 x 150

6. DIMENSIONS AND PUNCTURE HOLE AREAS OF THE BPSI BARS

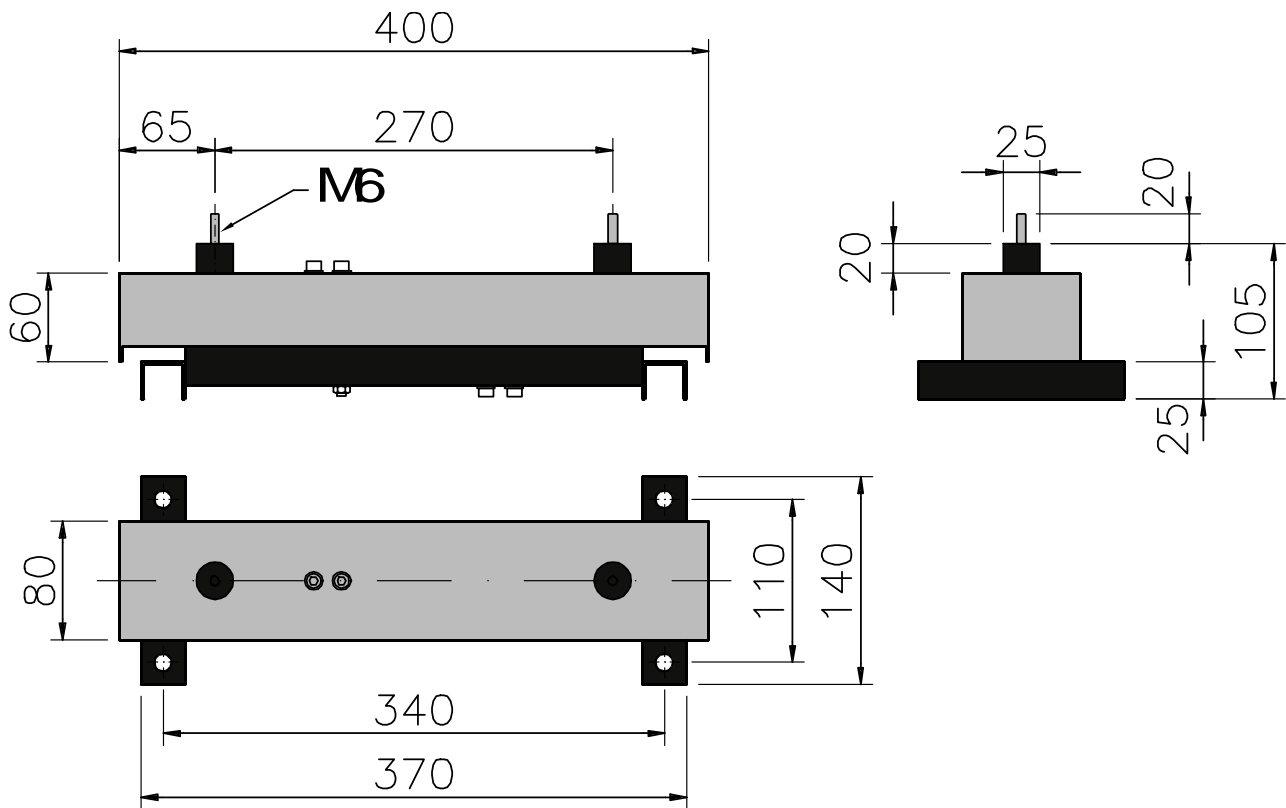

7. DIMENSIONS AND PUNCTURE HOLE AREAS OF THE BPM, BPX BARS

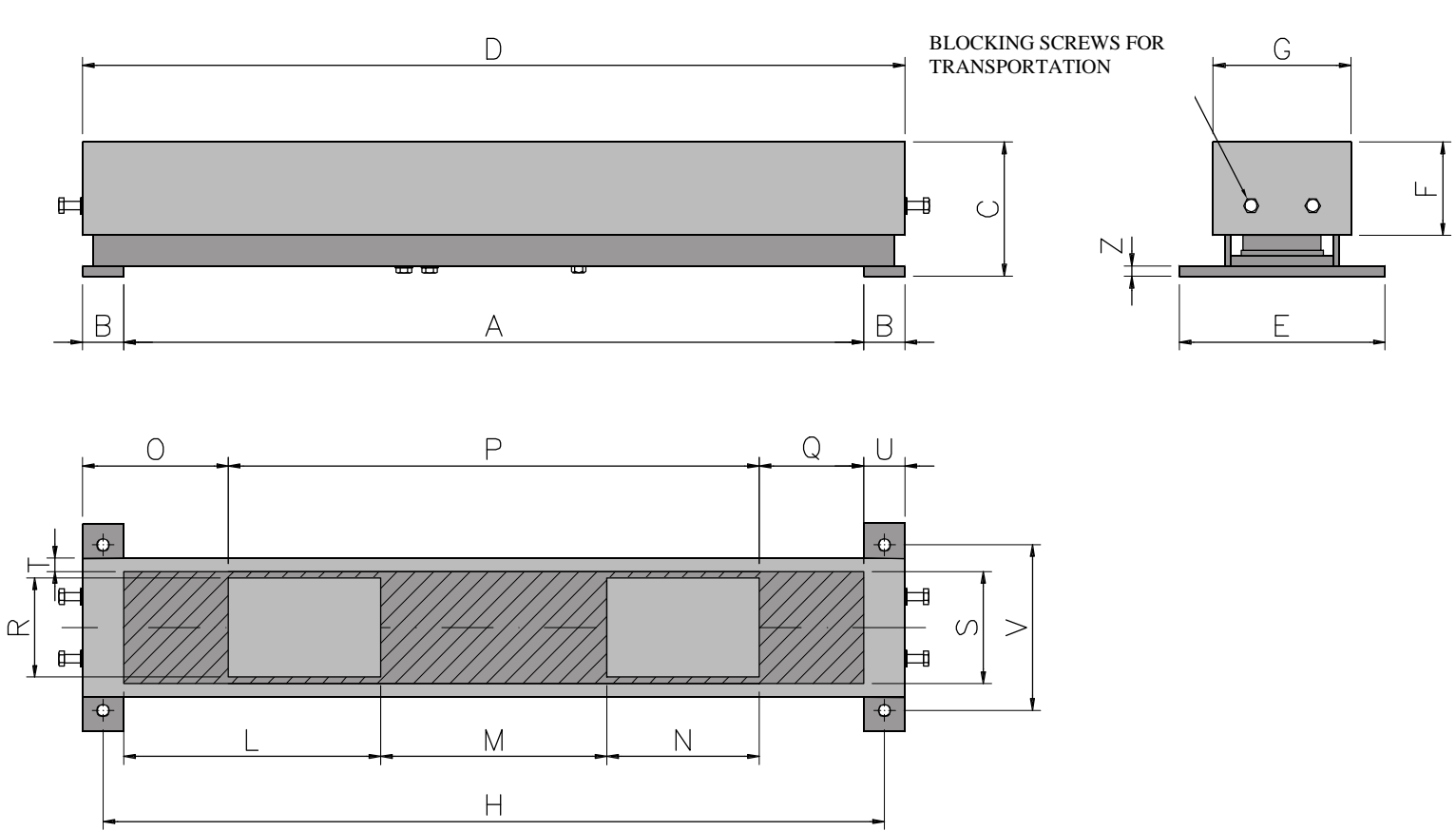

	BPM	BPX
A	520	720
B	40	40
C	130	130
D	600	800
E	170	200
F	90	90
G	105	134
H	560	760
L	182.5	250
M	160	220
N	107.5	148
O	112.5	142
P	375	516
Q	75	102
R	70	96
S	82	108
T	11.5	13
U	37.5	40
V	130	160
Z	10	10

- ZONES IN WHICH ONE CAN DRILL A HOLE
- ZONES IN WHICH ONE MUST NOT DRILL A HOLE

8. DIMENSIONS AND PUNCTURE HOLE AREAS FOR BPL BARS

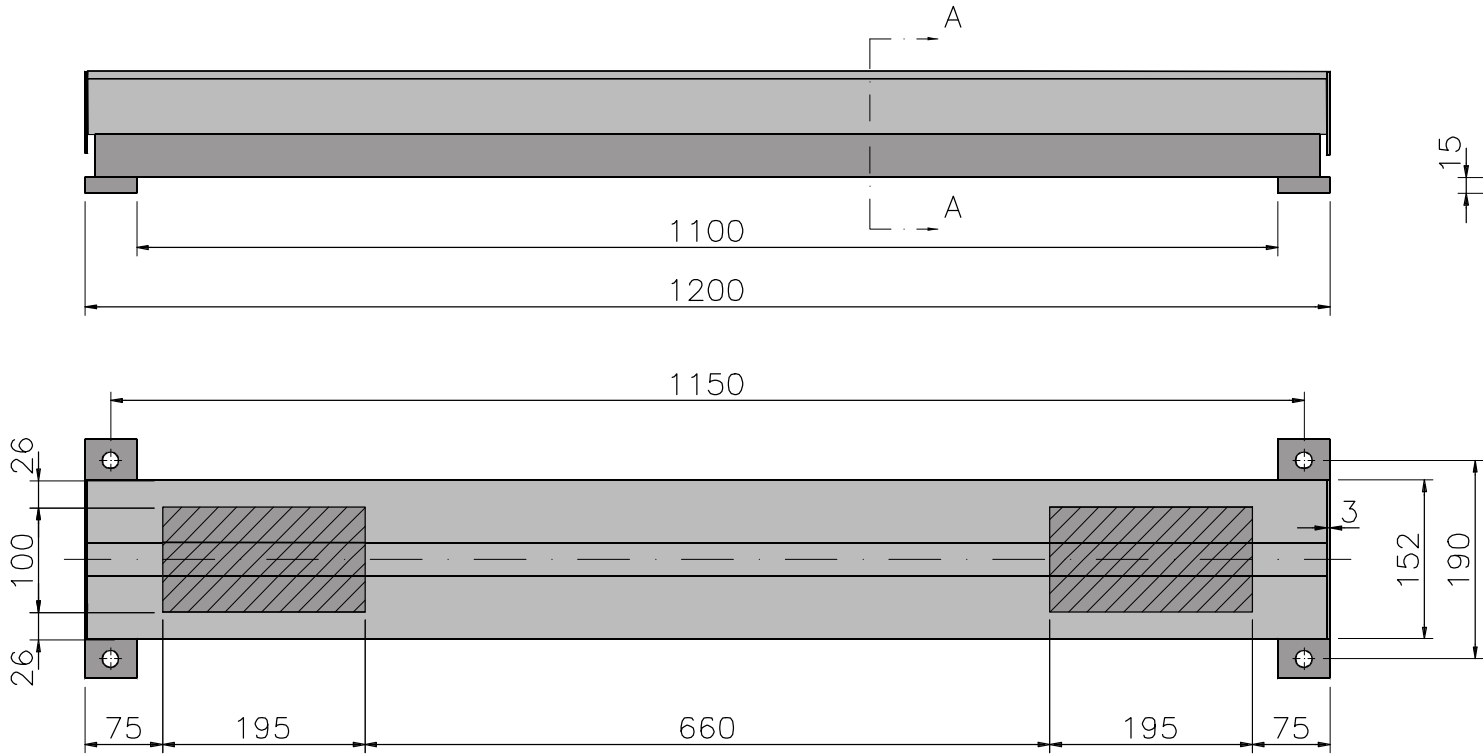
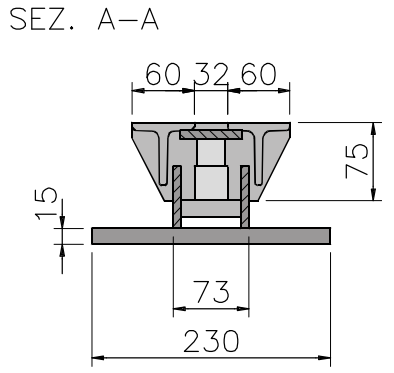

- ZONES IN WHICH ONE CAN DRILL A HOLE
- ZONES IN WHICH ONE MUST NOT DRILL A HOLE

9. EQUALISATION AND CALIBRATION INSTRUCTIONS OF A WEIGHING BAR SYSTEM (FIG.3)

- 1 Screw (turning clockwise) the screws of all the **T** trimmers, in order to have the maximum signal on all the cells.
 - 2 Carry out the calibration putting the weight in the center, with a weight of about 1/3 of the capacity.
 - 3 Put the sample weight on the 4 angles (**1, 2, 3, 4**) in the same manner and locate the cell which has the lowest displayed weight.
 - 4 Adjust the remaining 3 cells so that the these have the weight equal to the cell with the lowest signal; do this by:
 - A. Positioning the sample weight on the angle corresponding to the cell with the greatest weight.
 - B. Unscrewing (turning counterclockwise) the screw of the **T** trimmer of the corresponding cell until you have a weight value equal to that of the cell with the lower weight value.
 - C. Repeating actions "A" and "B" for the remaining two angles.
 - 5 Check again that all four angles indicate the same weight value. Otherwise, repeat points 3 and 4. If so, carry out again the calibration and put the weight in the center.
- N.B.** For a good outcome of the equalization of the system one should use a sample weight of small dimensions, about 1/3 of the scale capacity, so that the load is concentrated on each single cell.

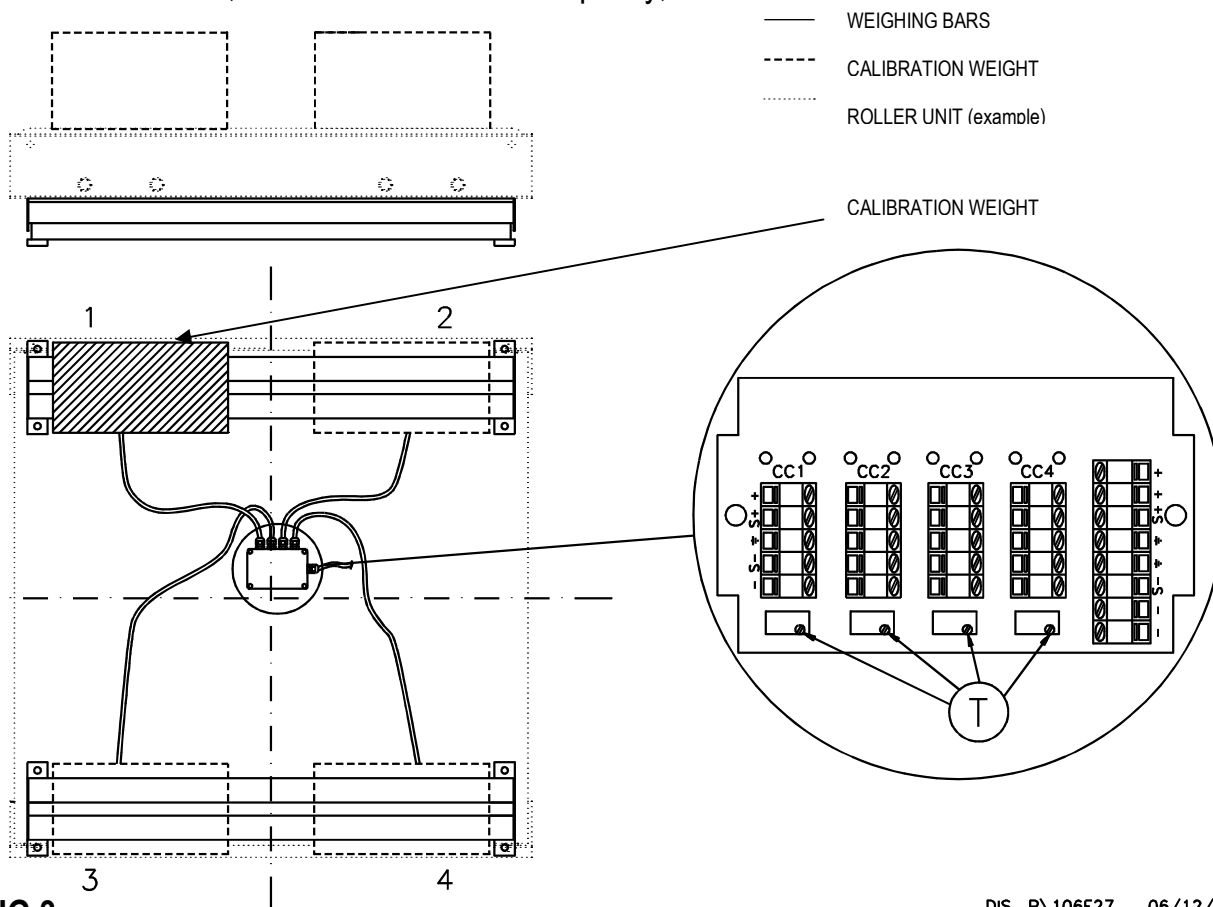

FIG.3

DIS. P\106F27 06/12/02

NOTES:

Adjust the weighing bars so that these lie flat.

Wire the eventual other cables (motors, photo cells, etc.) connected to the roller unit (for example) in order to have horizontal stretches which don't produce friction which could influence and not make the weigh repeatable

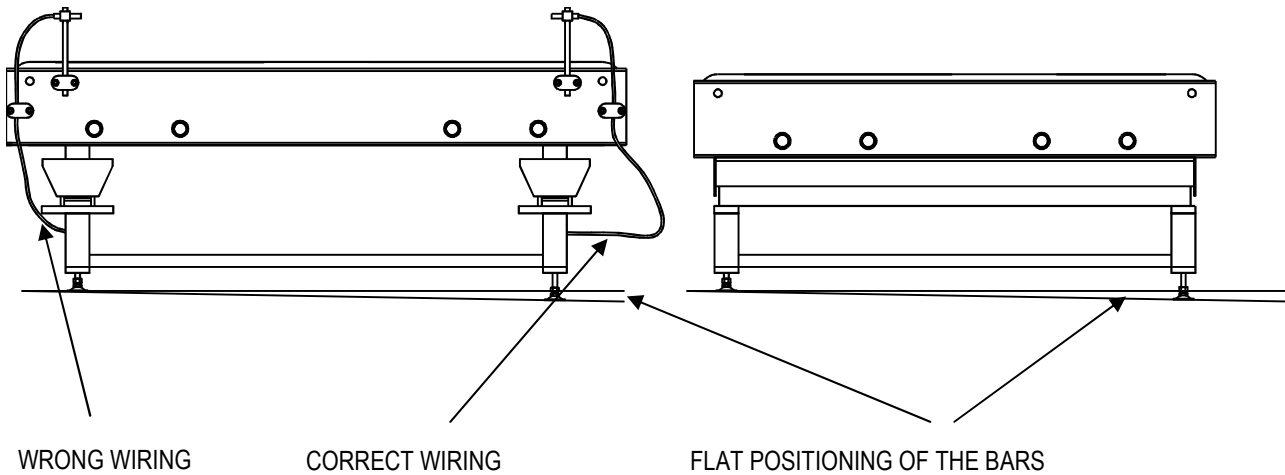

DIS. P\106F28 06/12/02

10. SHIELDED CONNECTION CABLE BETWEEN THE JUNCTION BOX (JBOX) AND INDICATOR

INPUT +	Brown
SENSE +	Green
INPUT -	Grey
SENSE -	White
OUTPUT +	Pink
OUTPUT -	Yellow
SHEATHING	Orange

WARRANTY

The TWO YEARS warranty period begins on the day the instrument is delivered. It includes spare parts and labour repair at no charge if the INSTRUMENT IS RETURNED prepaid to the DEALER'S PLACE OF BUSINESS. Warranty covers all defects NOT attributable to the Customer (such as improper use) and NOT caused during transport.

If on site service is requested (or necessary), for any reason, where the instrument is used, the Customer will pay for all of the service technician's costs: travel time and expenses plus room and board (if any).

the Customer pays for the transport costs (both ways), if the instrument is shipped to DEALER or manufacturer for repair.

The WARRANTY is VOIDED if any of the following occurs: repairs or attempted repairs are made by unauthorized personnel, connected to equipment installed by others, or is incorrectly connected to the power supply, or instrument has defects or damage due to carelessness or failure to follow the guidelines in this instruction manual.

This warranty DOES NOT provide for any compensation for losses or damages incurred by the Customer due to complete or partial failure of instruments, even during the warranty period.

AUTHORIZED SERVICE CENTRE STAMP

