

*Campagnolo*®

REAR  
DERAILLEUR

USER MANUAL

**WARNING!**

Carefully read, follow and understand the instructions given in this manual. It is an essential part of the product, and you should keep it in a safe place for future reference.

**MECHANIC QUALIFICATION** - Please be advised that many bicycle service and repair tasks require specialized knowledge, tools and experience. General mechanical aptitude may not be sufficient to properly service or repair your bicycle. If you have any doubt whatsoever regarding your service/repair ability, please take your bicycle to a qualified repair shop.

**"AN ACCIDENT"** - Please note that throughout this manual, reference is made that "an accident" could occur. Any accident could result in damage to your bicycle, its components and, more importantly, could cause you or a bystander to sustain severe personal injury or even death.

**INTENDED USE** - This Campagnolo® product is designed and manufactured for use only on road racing style bicycles that are ridden only on smooth road or track surfaces. Any other use of this product, such as off-road or on trails is forbidden.

**LIFESPAN - WEAR - INSPECTION REQUIREMENT** - The lifespan of Campagnolo® components depends on many factors, such as rider size and riding conditions. Impacts, falls, improper use or harsh use in general may compromise the structural integrity of the components and significantly reduce their lifespan. Some components are also subject to wear over time. Please have your bicycle regularly inspected by a qualified mechanic for any cracks, deformation, signs of fatigue or wear (use of penetrating fluid or other visual enhancers to locate cracks on parts is recommended). If the inspection reveals any deformation, cracks, impact marks or stress marks, no matter how slight, immediately replace the component; components that have experienced excessive wear also need immediate replacement. The frequency of inspection depends on many factors; check with your authorized Campagnolo® representative to select a schedule that is best for you.

If you weigh 82 kg/180 lbs or more, you must be especially vigilant and have your bicycle inspected more frequently (than someone weighting less than 82 kg/180 lbs) for any evidence of cracks, deformation, or other signs of fatigue or stress. Check with your mechanic to discuss whether the components you selected are suitable for your use, and to determine the frequency of inspections.

The components of Campagnolo® 10s transmissions, as well as the brakes, rims, pedals and all other Campagnolo® products are designed as a single integrated system. Not to affect safety, performance, longevity, functionality and the WARRANTY, use exclusively the parts and components supplied or specified by Campagnolo S.r.l., without interfacing or replacing them with products, parts or components manufactured by other companies.

**Note:** Tools supplied by other manufacturers for components similar to Campagnolo® components, may not be compatible with Campagnolo® components. Likewise, tools supplied by Campagnolo s.r.l. may not be compatible with components supplied by other manufacturers. Always check with your mechanic or the tool manufacturer to insure compatibility before using tools supplied by one manufacturer on components supplied by another.

*The user of this Campagnolo® product expressly recognizes that there are risks inherent in bicycle riding, including but not limited to the risk that a component of the bicycle can fail, resulting in an accident, personal injury or death. By his purchase and use of this Campagnolo® product, the user expressly, voluntarily and knowingly accepts and/or assumes these risks, including but not limited to the risk of passive or active negligence of Campagnolo s.r.l. or hidden, latent or obvious defects in the product, and agrees to hold Campagnolo s.r.l. harmless to the fullest extent permitted by law against any resulting damages.*

## SAFETY RECOMMENDATIONS

- Please be advised that if the maintenance and repair procedures provided in this manual are not properly performed, or if the other instructions in this manual are not followed, an accident could occur.
- Never make any modifications whatsoever to any component of any Campagnolo® product.
- Parts which have been bent or otherwise damaged in an accident or as a result of any other impact must not be re-straightened. They must be replaced immediately with original Campagnolo® parts.
- Wear clothes which are snug-fitting and which make you visible to traffic, such as neon fluorescent or other bright colors.
- Avoid biking at night because it is more difficult for you to be seen by traffic, and it is more difficult for you to see obstructions on the ground. If you do ride at night, you should equip your bicycle with and use a headlight and a tail light.
- Never use a bicycle or bicycle component unless you are thoroughly familiar with its use and maintenance history. "Used" equipment may have been misused and abused, and can unexpectedly fail resulting in an accident.
- When riding in wet conditions, remember that the stopping power of your brakes is greatly reduced and that the adherence of the tires on the ground is considerably reduced. This makes it harder to control and stop your bicycle. Extra care is required when riding your bicycle in wet conditions to avoid an accident.
- Always wear a properly fitted and fastened bicycle helmet that has been approved by ANSI or SNELL.

## BEFORE USING YOUR BICYCLE

- DO NOT RIDE YOUR BICYCLE IF IT DOES NOT PASS THIS PRE-RIDE TEST CORRECT ANY CONDITION BEFORE YOUR RIDE.
- Be sure that all of the components of your bicycle, including but not limited to your brakes, pedals, handgrips, handlebars, frame and seating system, are in optimum condition and suitable for use.
  - Be sure that none of the components of bicycle are bent, damaged or out of alignment.
  - Check to be sure that all quick release fasteners, nuts and bolts are properly adjusted. Bounce the bicycle on the ground and listen and look for anything which may be loose.
  - Be sure that your wheels are perfectly centred. Spin the wheels to be sure that they do not wobble up and down or from side to side, and that they do not make contact with the fork legs or brake pads while rotating.
  - Check all reflectors to make sure that they are clean, straight and securely mounted.
  - Check you brake pads and cables to be sure they are in good condition.
  - Test your brakes in the beginning of your ride to make sure that they are operating properly.
  - Learn and follow the local bicycle laws and regulations, and obey all traffic signals, signs and laws while you ride.

**If you ever any comments, questions or concerns, please contact your nearest Campagnolo Service Center. A list of service centers may be found on our website at [www.campagnolo.com](http://www.campagnolo.com).**

## IMPORTANT

Always check the tables in the product technical manual to ensure compatibility with the previous Campagnolo ranges.

## 1 - INFORMATION AND TECHNICAL SUPPORT

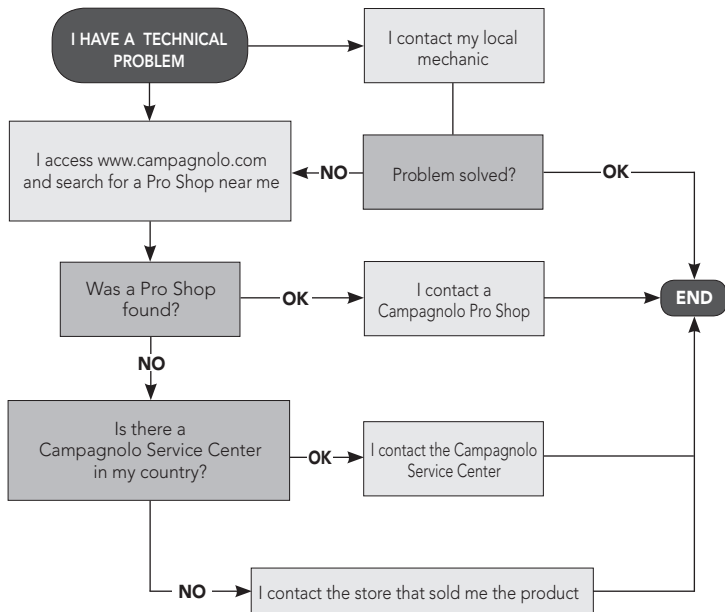

NOTE FOR SPECIALISED MECHANICS: Please remember that all assembly, disassembly, adjustment and maintenance procedures for the EPS drivetrain are described in the EPS technical manual, which is available in PDF format on our internet site [www.campagnolo.com](http://www.campagnolo.com). Scan this QR CODE to directly access the main page



Scan this QR CODE to access the search page to find your closest Campagnolo Pro Shop, or go to [www.campagnolo.com](http://www.campagnolo.com).



## 2 - PREPARING THE FRAME

**WARNING!**

Always wear protective gloves and glasses while working on the rear derailleur.

- Check that the Campagnolo® plate (Fig. 1) is fitted under the bottom bracket shell.

**CAUTION**

NEVER straighten the dropout with the rear derailleur assembled because you could damage the dropout and cause irreparable damage or loss in functionality to your rear derailleur.

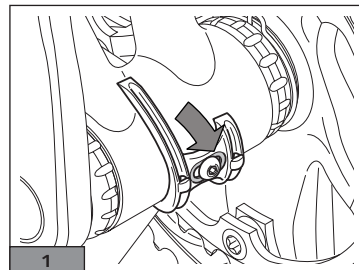

- Clear the threading of the rear derailleur connection fitting on the right rear dropout (B - Fig. 2) using a tool tap with threading 10x26 TPI.

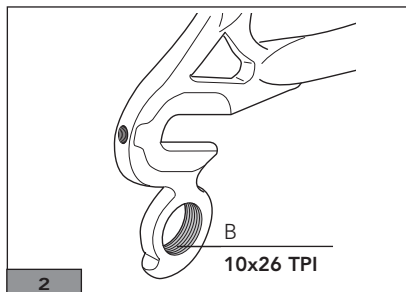

### 3 - INSTALLATION

- Secure the rear derailleur to the frame using screw (A - Fig. 3), and tighten with a 5 mm Allen wrench/ torx T25 key (**only for Centaur black and red**).

Tightening torque: **10 - 12 Nm**  
(**89 - 106 in.lbs**)

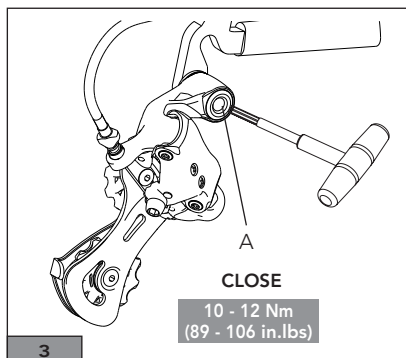

### 4 - CABLE ASSEMBLING AND ADJUSTING

- Carry out this adjustment with the chain on the smallest freewheel sprocket and with the Ergopower control button zeroed (Fig. 4).

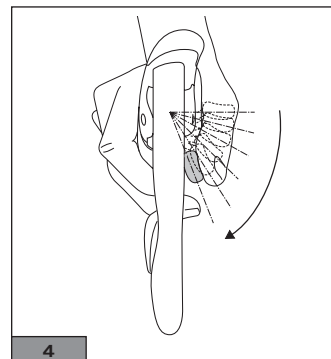

- Turn the screw (B - Fig. 5) until perfect alignment is obtained between the centreline of the top roller and the axis of the first sprocket (Fig. 6).

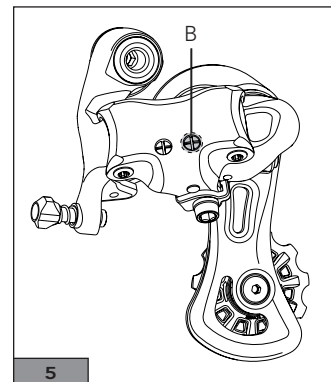

- Check the length and, if necessary, shorten the casing. Take care to cut it straight across without altering the configuration of the casing and without damaging the cable in any way. If the cable is damaged, please replace it before riding your bicycle. If the casing is too short, rear derailleur operation will be affected.

**Cables and casings do not require lubrication since they are supplied already lubricated.**

- Pass the cable through the adjustment screw (C - Fig. 8) and insert the end of the casing; then pass the cable underneath the plate (E - Fig. 8) and clamp it by tightening the Allen screw (D - Fig. 8) at a tightening torque of **6 Nm (53 in.lbs)**.

- Cut the excess cable at about two cm. from the clamping screw and protect the end with a cable cap.

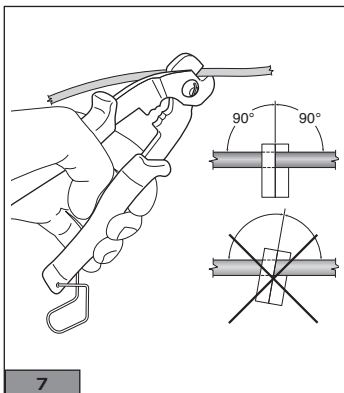
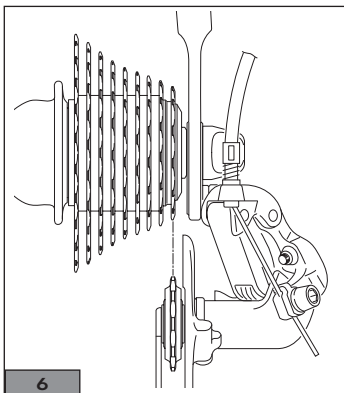

- Make sure that the screw (G - Fig. 10) is correctly adjusted: by operating the gear lever with the chain on the largest sprocket, the inner plate of the derailleur cage must **NOT** come into contact with the spokes.

- Position the chain on the 4<sup>th</sup> sprocket counting from the smallest.

- Turn the cable tension adjuster (F - Fig. 9) until perfect alignment is obtained between the centreline of the top roller and the centreline of the 4<sup>th</sup> sprocket.

- If centering the roller and the 4<sup>th</sup> sprocket is not correct, turn the adjuster (F - Fig. 9) counterclockwise to shift the rear derailleur inwards. Turn clockwise to shift the rear derailleur outwards.

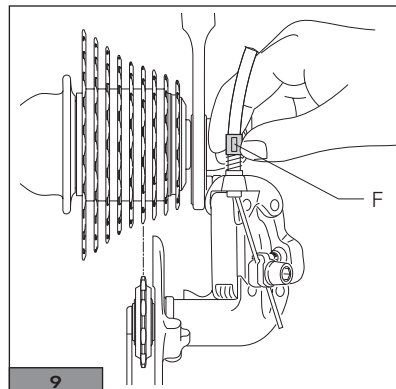
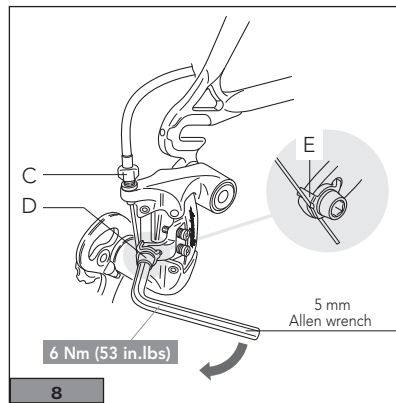

- Check that when the shifter is actuated accordingly, the rear derailleur positions the chain on the largest sprocket; if this does not occur, turn the screw (G - Fig. 10) repeatedly (slackening it until the chain is positioned on the largest sprocket without overshifting).
- Make sure that all gear ratios work perfectly.
- Fit the chain on the max. sprocket and on the smallest front chainring.

### ⚠ WARNING!

**Derailleur adjustments must be performed by skilled personnel: a badly adjusted derailleur can result in an accident, personal injury or death.**

- Adjust the screw (H - Fig. 10) and position the derailleur cages as in Fig. 11. A distance which is too great or too small compared with the specifications indicated could have a negative impact on snappy shifting.

#### Caution

While using the bike with the sprockets / chainrings at opposite extremes some noisiness is possible and the performance of the transmission is not the best.

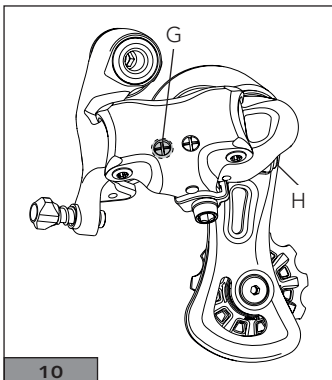

10

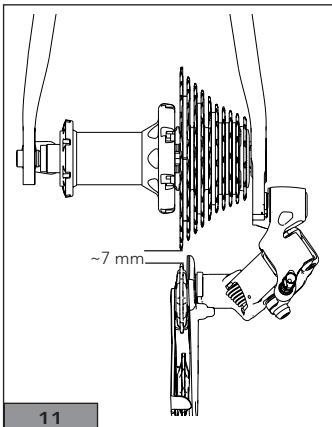

11

## 5 - MAINTENANCE / LUBRICATION / CLEANING

- If the rollers do not rotate smoothly, clean thoroughly and replace if necessary.
- To remove the rollers, unscrew the screws (C - Fig. 12) with a 3 mm Allen screw.

### ATTENTION!

The two rollers are different: on the upper section, fit the roller (A - Fig. 12) marked "UPPER" (with side play); in the lower section, fit the roller (B - Fig. 12) marked "LOWER": it is unidirectional and must be fitted so that it rotates in the direction indicated by the arrows (Fig. 13).

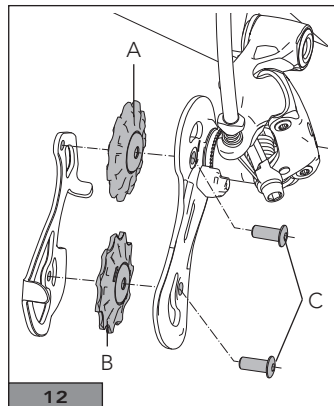

12

### WARNING!

Comply with the following specifications when replacing the pulleys:

**Tightening torque: 3 Nm (27 in.lbs)**

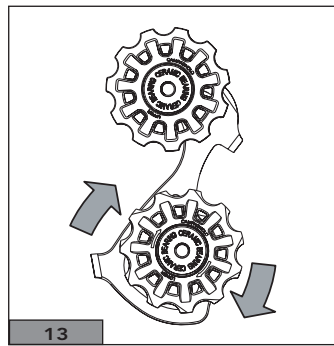

13

- The duration of the components is variable based on the conditions of use, frequency and quality of maintenance. For proper component maintenance, it is necessary to frequently perform the cleaning and lubrication operations, especially under conditions of heavy use (e.g. each time after washing the bicycle, after use in wet conditions, on dusty or muddy roads etc.).

- Check chapter 6 to determine the frequency with which you should have maintenance performed on your components by a specialised mechanic: Period maintenance.

- Dirt seriously damages the bicycle and its components. Wash, clean and dry your bicycle carefully after use.

- Never spray your bicycle with water under pressure. Pressurized water, even from the nozzle of a small garden hose, can pass under seals and enter your Campagnolo components, thereby affecting its operation. Wash your bicycle and Campagnolo components by wiping them down with water and neutral soap.

- Check that any holes on the bottom bracket shell are unobstructed and allow water infiltrating into the frame to drain.

### WARNING!

**Salty environments (such as winter roads or roads near the sea) may lead to galvanic corrosion of most of the bicycle's exposed components. To prevent damage, malfunctions and accidents, rinse, dry and carefully re-lubricate all components which are subject to this phenomenon.**

- Do not expose the products to high temperature, do not leave them closed in cars parked under the sun, do not keep them near radiators or other heat sources, do not leave carbon or plastic products in direct sunlight.

## 6 - PERIODIC MAINTENANCE

**Maintenance intervals are strictly approximate and may vary significantly in relation to the intensity and conditions of use (for example: competitions, rain, winter roads with salt, weight of the athlete, etc.). Schedule the appropriate maintenance with your mechanic.**

PROCEDURE	KM INDICATION (MAX)	TIME INDICATION (MAX)	CALCULATION METHOD
Occasionally lubricate the pivots	6000	6 months	
check alignment frame drop-out	1000	1 month	rear derailleur hanger eyelet alignment confirmation tool UT-VS030
Every time the wheels do not turn smoothly, clean them properly or replace them	1000	1 month	

### CAUTION

At the end of the lubrication operations, CAREFULLY degrease the braking rim and the brake blocks.