

Model: SWAT 2.4

Stereo Wireless Audio Transceiver

User Manual

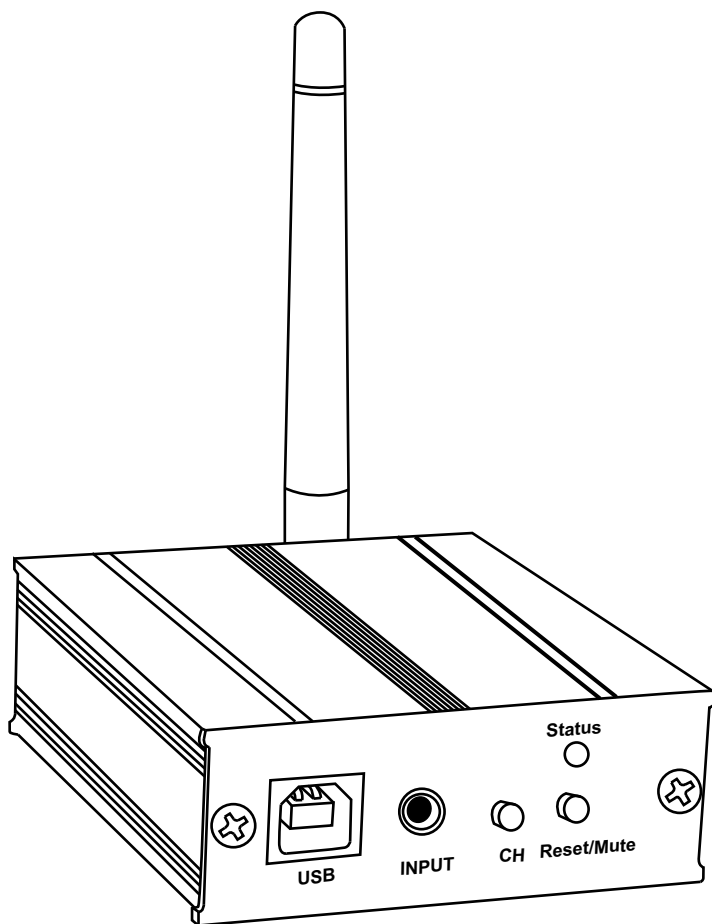

TRANSMITTER

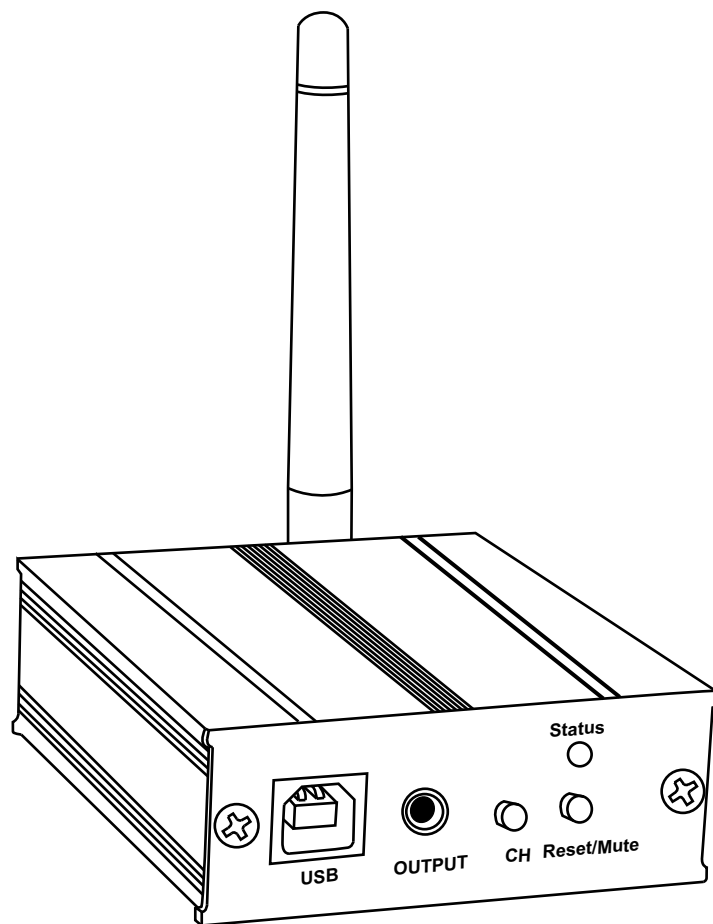

RECEIVER

Table of Contents

Introduction.....	2
Safety Instructions.....	2
Unpacking Tips.....	4
What Comes with SWAT 2.4.....	5
Applications.....	5
Features.....	5
Powering Your SWAT 2.4.....	6
Pairing Transmitter to Receiver.....	6
Channel Changing.....	6
Connecting Your SWAT 2.4.....	7
Interface.....	8
Specifications.....	9
Warranty Information.....	10



The Sound That Will *Move* You

Earthquake Sound Corporation
2727 McCone Avenue
Hayward, CA 94545
Tel: 510-732-1000
Fax: 510-732-1095

Customer Support
tech@earthquakesound.com
Tel: 800-576-7944
Fax: 510-732-1095

© 2009 Earthquake Sound Corporation. All rights reserved.

This document should not be construed as a commitment on the part of Earthquake Sound Corporation. The information is subject to change without notice. Earthquake Sound Corporation assumes no responsibility for errors that may appear within this document.

Introduction

SWAT 2.4 is a wireless audio transceiver that allows you to play audio material from your audio source player to almost any speaker wirelessly. Hard wiring your speakers to your sound source is costly and time consuming. SWAT 2.4 makes install a snap but does not compromise sound quality for convenience. It is extremely versatile and perfect for apartments or outdoor settings. It even has microphone capability so you can transmit voice as well.

SWAT 2.4 consists of a Transmitter (a unit that connects to the source) and a Receiver (a unit that connects to the amplifier or powered speaker). The SWAT 2.4 Transmitter connects to a stereo, MP3 player, computer, or any other device that can play audio through a 3.5mm stereo jack or RCA output. The Receiver is then connected to an amplifier or a powered speaker through an RCA input. Multiple Receivers can connect wirelessly to one Transmitter if you want the music to play in different areas or on multiple systems. Extra Receivers can be purchased separately.

Once the Transmitter and Receiver are paired, the Receiver will receive signals from the Transmitter automatically. If there is any interference on the current channel, all you have to do is change to the channel of the Transmitter; the Receiver can sense the frequency change and will adjust automatically. It has 20 available channels, more channels than any other wireless transceiver has to date. There is also a one in 20 million chance that the pairing channel will interfere with a different signal.

Both the Transmitter and the Receiver must be connected to a power source of which there are two options. One is the DC power supply which connects to any wall outlet, and the other is USB.

Safety Instructions

Safety First

This documentation contains general safety, installation, and operating instructions for SWAT 2.4. It is important to read this user's manual before attempting to use these products. Pay particular attention to the safety instructions.

Symbols Explained:



Appears on the component to indicate the presence of uninsulated, dangerous voltage inside the enclosure – voltage that may be sufficient to constitute a risk of shock.



Calls attention to a procedure, practice, condition or the like that, if not correctly performed or adhered to, could result in injury or death.



Calls attention to a procedure, practice, condition or the like that, if not correctly performed or adhered to, could result in damage to or destruction of part or all of the product.

Note:

Calls attention to information that is essential to highlight.

Important Safety Instructions

- 1) Read these instructions in their entirety.
- 2) Store this manual and packaging in a safe place.
- 3) Heed all warnings.
- 4) Follow instructions (do not take short cuts).
- 5) Do not use this apparatus near water.
- 6) Clean only with a dry cloth.
- 7) Do not block any ventilation openings. Install in accordance with the manufacturers instructions.
- 8) Do not install near any heat sources such as radiators, heat registers, stoves, or other apparatuses that produce heat.
- 9) Do not defeat the safety purpose of the polarized or grounding-type plug. A polarized plug has two blades with one wider than the other. A grounding-type plug has two blades and a third grounding prong. The wide blade or the third prong is provided for your safety. If the provided plug does not fit into your outlet, consult an electrician for replacement of the obsolete outlet.
- 10) Protect the power cord from being walked on or pinched, particularly at plugs, convenience receptacles, and the point where they exit from the apparatus.
- 11) Only use attachments & accessories specified by the manufacturer.
- 12) Use only compatible rack or cart for final resting position.
- 13) Unplug this apparatus during lightning storm or when unused for long period of time.
- 14) Refer all servicing to qualified service personal. Servicing is required when the apparatus has been damaged in any way such as; power-supply cord or plug is damaged, liquid has been spilled or objects have fallen into the apparatus, the apparatus has been exposed to rain or moisture, does not operate normally, or has been dropped.
- 15) To reduce the risk of fire or electric shock, do not expose this apparatus to rain or moisture.

This triangle, which appears on your component, alerts you to the presence of uninsulated, dangerous voltage inside the enclosure - voltage that may be sufficient to constitute a risk of shock.

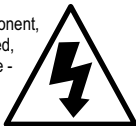

This triangle, which appears on your component, alerts you to important operating and maintenance instructions in this accompanying literature.



Unpacking system components

- Keep the original carton and packing materials for future shipment or storage.
- Check for any visual signs of damage. If you encounter any concealed damage, consult your Earthquake Sound dealer before proceeding with unit installation.
- Retain the sales receipt as it established the duration of the limited warranty and provided information for insurance purposes.

System installation considerations

There are several factors to consider before installing Earthquake Sound's SWAT 2.4.

- What are the intended listening zones?
- What system options and accessories might be required for features such as local sources, etc.?
- From where in each zone will the listener prefer to control the system? Where will the remote gains be located? Where will the speakers be located?
- Where will the source equipment be located?

Connection tips

- Keep all power cords away from all signal cables to prevent humming from induced noise.
- Choose reliable signal cables cords (Earthquake Sound also specializes in high-performance RCA cables and patches).
- All speaker wires that are ran through the walls should be twisted type to reduce potential hum noise pick up.
- Label both ends of all wires with the corresponding room location.
- It is best to use a grounded electrical outlet to power the amplifier. Lack of input ground reference could be unsafe. Consult with your electrical contractor about proper grounding.

Your SWAT 2.4 Comes With:

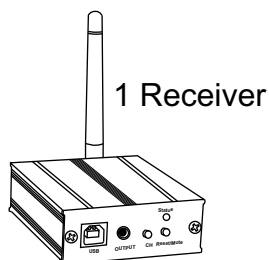
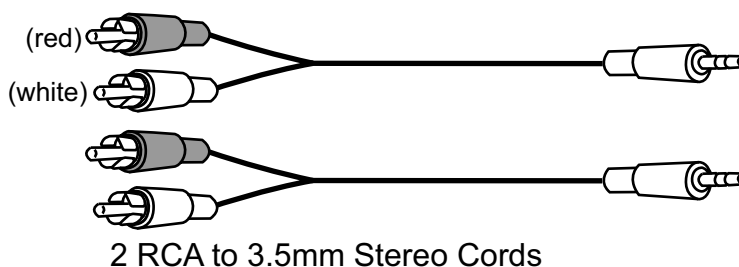
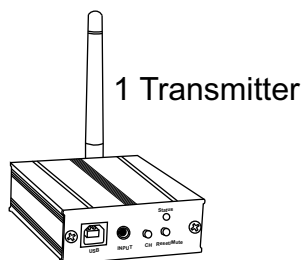

(Extra Receivers Sold Separately)

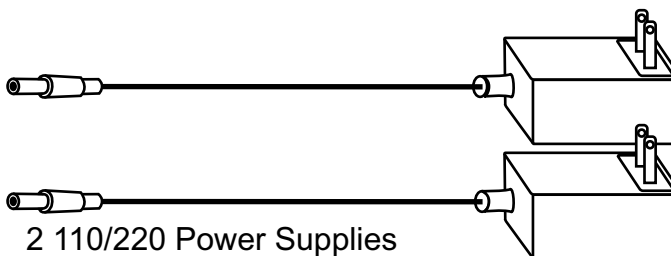
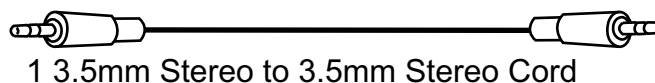

Applications

- Audio transmission in a large room (DJ)
- Outdoor speakers (BBQ, Patio, Pool)
- Wireless audio transmission for surveillance
- Paging System
- Wireless microphones or loudspeakers
- iPod, sound card, CD, DVD, MP3 players or other music players
- Wireless headphones
- Ambient music (in setting of offices, hospitals, waiting rooms)



smart phone



computer

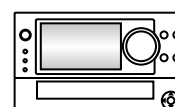

stereo

Features

- Frequency: 2400-2528MHz
- Channels: 20
- Two types of inputs supporting microphones and stereo
- Digital transmission
- Highest sampling ratios: 64k @ 16 bit x 2, frequency response 2000kHz; HDCD sound effect
- Lowest latency (<0.5ms), and good quality of surround
- Low power consumption for a wide range of input voltage supporting
- Audio muting function when receiving weak signal or no signal
- Auto channel scanning function

Powering Your SWAT 2.4

- **Connection of power to Transmitter:** the Transmitters are strictly tested before delivery to ensure the highest quality possible. They are matched and ready to work as soon as they are plugged in and switched on. You can connect the 110/220 Power Supply to the Transmitter and connect the other end to a wall outlet. Or, you can use a USB cable and power it through your computer. The LED will remain on, indicating that the Transmitter is working properly.
- **Connection of power to Receiver:** the Receivers are strictly tested before delivery to ensure the highest quality possible. The Receiver has the same powering options as the Transmitter. When powered and switched on, the LED light remains off, indicating that the receiver is working properly. If the LED light is on, the Receiver cannot receive the signal or there is a working problem.
- **Audio Connection:** Turn to the next page for instructions on connecting your SWAT 2.4 to audio devices.

Pairing the Transmitter to Receiver

Before SWAT 2.4 is shipped, the Transmitter and the Receiver are already paired. However, here are instructions for point to point pairing in the event that they are not paired or they lose connection. There are also instructions for point to mass pairing (connecting one Transmitter to multiple Receivers).

Point to Point Pairing (Connecting 1 Transmitter to 1 Receiver)

- Press and hold down the CH buttons on both the Transmitter and the Receiver at the same time for more than 3 seconds, until the LED lights are on. The Transmitter light will flicker for 5 seconds indicating that the Transmitter and the Receiver are pairing.
Note: If successfully paired, the LED light on the Transmitter will flicker 5 times and the Receiver will flicker 3 times. Normally the LED light will then turn off if the receiver is successfully paired with the transmitter.

Point to Mass Pairing (Connecting 1 Transmitter to multiple Receivers)

- **Connecting the Transmitter:** Press and hold down the CH button for more than 3 seconds until the LED light turns on, then release the button. The light will flicker for 5 seconds, within these 5 seconds press and hold the CH button again. The LED light will keep flickering indicating that the Transmitter is in mass-pairing mode.
Note: DO NOT release the CH button until the Transmitter has paired with all of the Receivers.
- **Connecting the Receivers:** While holding down the CH button on the Transmitter, press down the CH button on the Receiver for more than 3 seconds. After you release the button, the light will flicker for 5 seconds indicating it is finding the Transmitter. Once the Receiver has paired with the Transmitter, the LED light will flicker 3 times. When it is done pairing, the LED light will turn off. Repeat this process for each of the Receivers. Once all the Receivers have been paired, release the Transmitter CH button.

Channel Changing

The SWAT 2.4's state of the art technology includes an effective anti-jamming feature, which is able to fully shield the interference from common cordless telephones, mobile phones, walkie-talkie/two-way radios, and many other wireless facilities, leaving clear, high-fidelity, wireless audio frequency. However, in the rare cases when the wireless Transmitter tries to broadcast through the wrong channel, you can simply press the CH button and select a different channel. This is why the SWAT 2.4 offers 20 channels, more than any other transceiver on the market. It also has a channel tracking mode, in which the Receiver will automatically find the Transmitter's channel after it is changed.

- To manually change the channel, the Transmitter and the Receiver channels must be changed simultaneously.
- To automatically change the channel, pair the Transmitter and Receiver as described earlier (hold down the CH button on each unit at the same time for 3 seconds, until the LED light flickers).

Connecting your SWAT 2.4

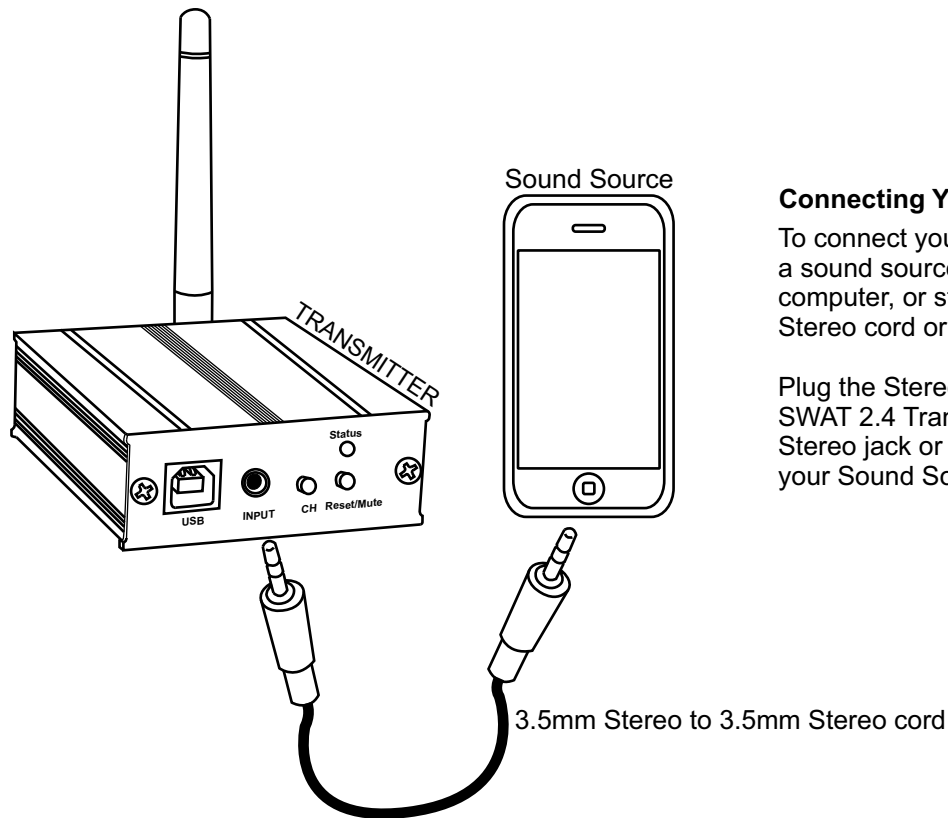

Connecting Your Transmitter

To connect your SWAT 2.4 Transmitter to a sound source, such as an MP3 player, computer, or stereo, use the Stereo to Stereo cord or the Stereo to RCA cord.

Plug the Stereo jack in the "INPUT" of your SWAT 2.4 Transmitter and plug the other Stereo jack or RCA jacks into the output of your Sound Source.

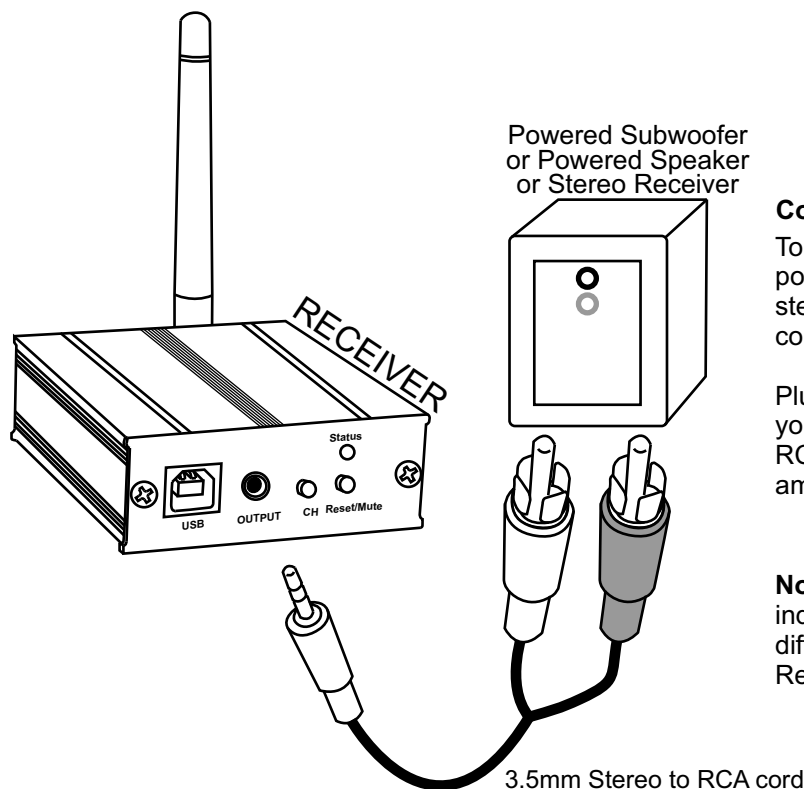

Connecting Your Receiver

To connect your SWAT 2.4 Receiver to a powered speaker/subwoofer, amplifier, or stereo receiver, use the Stereo to RCA cord.

Plug the Stereo jack in the "OUTPUT" of your SWAT 2.4 Receiver and plug the RCA jacks in the input of your speaker or amplifier.

Note: Each SWAT 2.4 unit has been individually marked on its underside to differentiate between the Transmitter and Receiver.

Interface

1) **USB-** USB power with a USB cable. Can plug in your computer's USB port for power using the computer to supply power for the Transmitter. This feature is great for laptop users.

Note: USB CONNECTION WILL NOT CARRY SIGNAL. FOR POWER ONLY.

2) **INPUT (or) OUTPUT-** Stereo audio input or output with a 3.5mm stereo outlet.

3) **CH-** Channel Selection is used for pairing ID (On both the transmitter and receiver, hold the channel buttons down at the same time for 3 seconds, until the LED light turns on. After you let go, the LED light will flicker for 5 seconds, indicating that it is searching for the other unit. To connect to multiple receivers, hold the button for longer than 3 seconds so it will keep pairing.)

4) **Status-** Light is on when unit is on.

5) **Reset/Mute-** Used when it is necessary to mute or reset the transmitter. Hold the button down and the transmitter will mute. Press it once and the transmitter resets itself and restarts.

6) **Power-** Switch of Power. When power supply is connected through the USB input or DC input and the switch is at OFF, the transmitter is turned off. When the switch is at ON, the transmitter is turned on.

WARNING DO NOT PLUG IN THE DC POWER SUPPLY AND THE USB POWER SUPPLY AT THE SAME TIME. ONLY ONE POWER SUPPLY IS NECESSARY.

7) **DC-** DC power interface. Positive inside and negative outside; Voltage: DC 3.6 – 6V

8) **ANT-** 2.4GHz antenna. The antenna can rotate 180 degrees. However, do not rotate past resistance. Earthquake Sound is not liable for antennas broken in this manner.

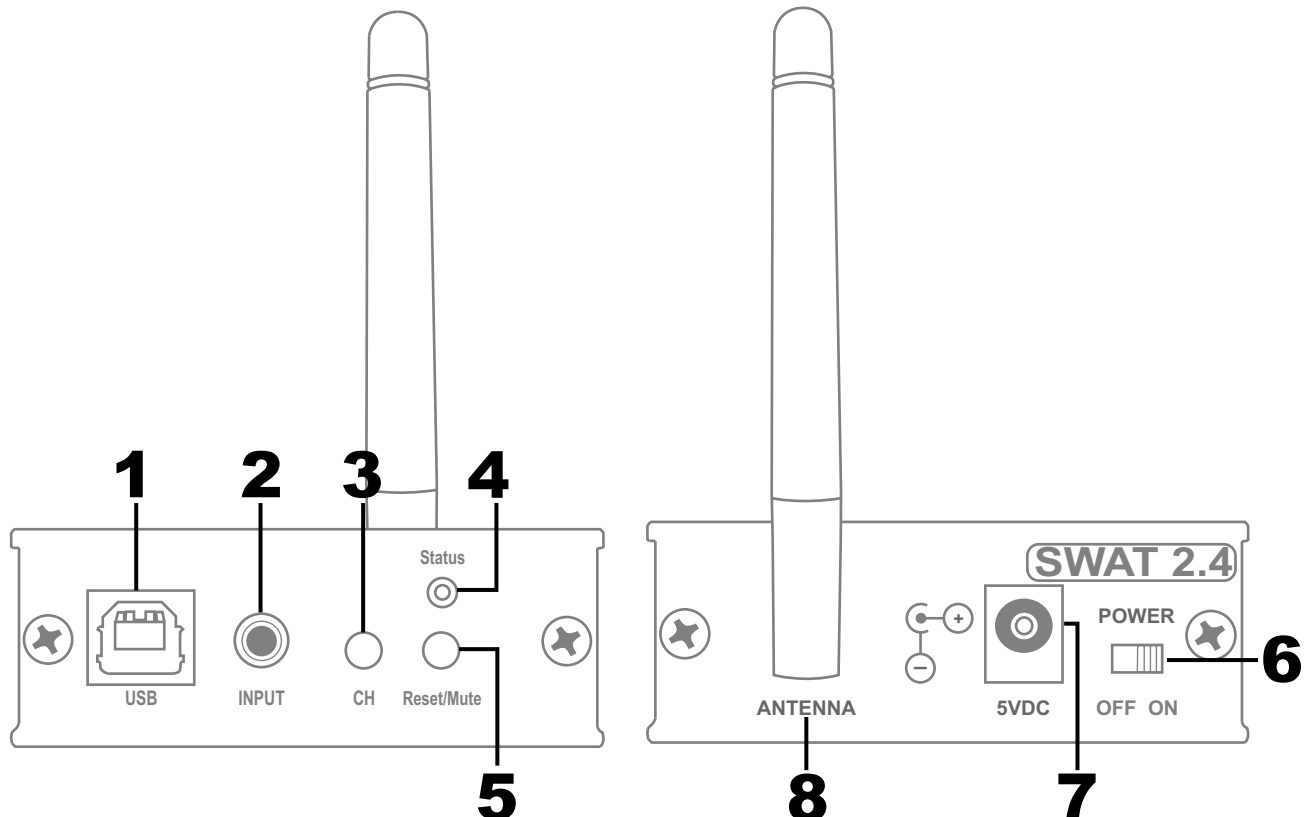

Specifications

	Transmitter	Receiver
Work Voltage	3.6 - 6V DC	3.6 - 6V DC
Work Current	Max 120mA	Max 40mA
Operation Temperature	-15 - 65° C	-15 - 65°C
Practical Mode Frequency Range	2400-2528MHz	2400-2528MHz
MODULATION	GFSK	
Band Rate	2 Mbps	2 Mbps
Frequency Stability	100kHz	100kHz
Selection of Channel	One-way circulation	Two modes: Auto scanning and manual selecting
Practical Working Channel	20 channels	20 channels
Channel Space	4MHz	4MHz
RF Range	Open field range test was free from interference up to 100 meters.	
TX Power	20dBm; variable from 0dBm up to 20dBm	
RX Sensitivity		-90dB
Input Level	Max 1.0Vpk	
Input Impedance	10k	
Input Interface	Phono audio input	
Stereo Output Level 1		30mW RL=32
Stereo Output Level 2		50mW RL=16
Output Impedance		1k
Gain ratio of output and input	1:1	
Frequency Response	20Hz-20kHz	
Latency	<0.5ms	
Sampling Ratio	65kHz at 16bit	
S/N Ratio	95dB	
THD	0.3%@1kHz	
Dynamic Range	90dB	
Channel Separation	85dB	
Dimensions (L x W x H)	3.15" x 2.7" x 1" (80mm x 69mm x 25mm)	

5 Year Limited Warranty Information

Earthquake warrants the original purchaser that all Factory Sealed New Audio Products be free from defects in material workmanship, under normal and proper use, for a period of five (5) years from the date of purchase (as shown on the original sales receipt with the serial number affixed/written on it).

The five (5) years warranty period is valid only if the product is properly installed by an Earthquake authorized party, and the warranty registration card is properly filled out and sent to Earthquake Sound Corporation. If the product is installed by a non-authorized party, a ninety (90) days warranty period applies.

(A) Five (5) years limited warranty plan coverage guidelines:

- First year: Earthquake pays for labor, parts, and ground freight (only in the U.S. mainland, not including Alaska and Hawaii) back to the customer.
- Second year: Earthquake pays for labor and parts only, customer must pay freight both ways.
- Third, fourth, and fifth year: Earthquake pays for labor only. Customer must pay for parts and freight both ways.

(B) Warning:

Products (sent for repair) that are tested by Earthquake technicians and deemed to have no problem, will not be covered by the five (5) years limited warranty. Customer will be charged a minimum of one (1) hour of labor (ongoing rates) plus shipping back to the customer.

(C) Earthquake agrees to repair or replace, at our option, all such defective products/parts subject to the following provisions:

- Defective products/parts have not been altered or repaired by other an Earthquake factory approved technician.
- Products/parts are not subjected to negligence, misuse, improper use, aor accident, damaged by improper line voltage, used with incompatible products, or have its serial number or any part of it altered, defaced, removed, or have been used in anyway that is contrary to Earthquake's written instructions.

(D) Warranty Limitations:

Earthquake warranty does not cover products that have been modified and/or abused, including but not limited to the following:

- Damages to unit cover and finish due to misuse, abuse, or improper use of cleaning materials/methods.
- Bent casing, damaged finish on casing due to abuse, misuse, or improper frame or broken connections.
- Fading, deterioration of components and finish due to improper exposure to elements.
- Burnt tracers of PCB.
- Product/part damaged due to poor packaging or abusive shipping conditions.
- Subsequent damage to other products.

A warranty claim will not be valid if the warranty registration card is not properly filled and returned to Earthquake with a copy of the sales invoice.

(E) Service Request:

To receive product(s) service, contact Earthquake Sound's service department at (510) 732-1000 and request an RMA number (Return Material Authorization), item(s) shipped without a valid RMA number will be refused. Make sure you provide us with your complete and correct shipping address, a valid phone number, and a brief description of the problem you are experiencing with the product. In most cases, our technicians might be able to resolve the problem over the phone, thus eliminating the need to ship the product.

(F) Shipping Instructions:

Product(s) must be packaged in its original protective box(es) to minimize transport damage. Shipper claims regarding item(s) damaged in transit must be presented to the carrier. Earthquake Sound Corporation reserves the right to refuse improperly packed product(s). A copy of original sales receipt must accompany product(s) returned for service. We encourage you to include a written description fo the problem inside the package. Ship to:

Earthquake Sound Corp.
2727 McCone Avenue
Hayward, CA 94545 USA

You are responsible for the cost of shipping the product to Earthquake Sound Corporation.

(G) Disputes Resolution:

All disputes, between clients and Earthquake Sound Corporation, resulting from the five (5) years limited warranty policy must be resolved according to the laws and regulations of the county of Alameda, California.



Sound That Will Move You

Earthquake Sound reserves the right to amend details of the specifications without notice.

© Copyright Earthquake Sound Corporation
Earthquake Sound Corporation
2727 McCone Avenue, Hayward CA, 94545
Phone: (510) 732-1000 Fax: (510) 732-1095