

# PCIE-Q670

**Full-size PICMG 1.3 CPU card Supports**

**LGA1155 Intel<sup>®</sup> Core<sup>™</sup>**

**i7/i5/i3/Pentium<sup>®</sup> /Celeron<sup>®</sup> CPU with Intel<sup>®</sup>  
Q67, DDR3, VGA/DVI-D, Dual Intel<sup>®</sup> PCIe  
GbE, SATA 6Gb/s, PCIe Mini, HD Audio  
and RoHS**

## USER'S MANUAL (V1.0)

健昇科技股份有限公司

**JS AUTOMATION CORP.**

新北市汐止區中興路 100 號 6 樓

6F., No.100, Zhongxing Rd.,

Xizhi Dist., New Taipei City, Taiwan

TEL : +886-2-2647-6936

FAX : +886-2-2647-6940

<http://www.automation.com.tw>

<http://www.automation-js.com/>

E-mail : [control.cards@automation.com.tw](mailto:control.cards@automation.com.tw)

# CONTENTS

1. Forward.....	2
2. Features.....	3
3. Specifications.....	4
4. Dimensions(mm) .....	6
4.1 PCIE-Q670 Series Dimensions (mm).....	6
4.2 External Interface Panel Dimensions (mm).....	6
5. Jumper and Connector .....	7
5.1 Jumper and Connector Locations .....	7
5.2 Peripheral Interface Connectors.....	8
5.3 External Interface Panel Connectors.....	8
6. Connector and Jumper setting.....	9
6.1 Internal Peripheral Connectors .....	9
6.1.1 12V Power Connector (CPU12V1) .....	9
6.1.2 Audio Kit Connector (J_AUDIO1) .....	9
6.1.3 Battery Connector (BAT1).....	9
6.1.4 DDR3 DIMM Slots (CHA_DIMM1, CHB_DIMM1).....	9
6.1.5 Digital I/O Connector (DIO1).....	10
6.1.6 DVI-D Connector (DVI Model Only) (DVI1) .....	10
6.1.7 Fan Connector (CPU) (CPU_FAN1) .....	10
6.1.8 Floppy Disk Drive Connector (FDD1) .....	11
6.1.9 Front Panel Connector (F_PANEL1).....	11
6.1.10 I2C Connector (I2C_1) .....	12
6.1.11 Infrared Interface Connector (IR1 CN) .....	12
6.1.12 Keyboard/Mouse Connector (KB_MS1) .....	12
6.1.13 Parallel Port Connector (LPT1) .....	13
6.1.14 PCIe Mini Card Slot(CN3) .....	14
6.1.15 SATA 3Gb/s Drive Connectors (SATA3, SATA4, SATA5, SATA6).....	15
6.1.16 SATA 6Gb/s Drive Connector(SATA1, SATA2).....	15
6.1.17 Serial Port Connectors, RS-232(COM1, COM2).....	15
6.1.18 Serial Port Connector, RS-422/485 (COM4).....	16
6.1.19 SMBus Connector (SMBUS_1).....	16
6.1.20 SPI ROM Connector (JSPI1).....	16
6.1.21 TPM Connector (TPM1).....	16
6.1.22 USB Connectors (USB1, USB2, USB3) .....	17
6.2 External Peripheral Interface Connector Panel.....	17
6.2.1 Ethernet Connectors (LAN1 and LAN2).....	17
6.2.2 USB Connectors (USB_C1 and USB_C2) .....	18
6.2.3 VGA Connector (VGA1).....	18
7. Ordering Information.....	19

## 1. **Forward**

---

Thank you for your selection of PCIE-Q670 cpu card.

Any comment is welcome,

please visit our website: [www.automation.com.tw](http://www.automation.com.tw) for the up to date information.

## 2. Features

- PICMG 1.3 full-size graphics grade solution
- LGA1155 CPU socket
- Intel® Q67 chipset
- Dual-channel DDR3 DIMMs support up to 16.0 GB
- Dual independent display by VGA and DVI-D (DVI model only)
- One PCIe Mini expansion slot
- Two Intel® PCIe Gigabit Ethernet connectors (LAN2 with Intel® AMT 7.0 support)
- Two SATA 6Gb/s connectors with RAID function
- Four SATA 3Gb/s connectors with RAID function
- TPM V1.2 hardware security function supported by the TPM module
- High Definition Audio
- RoHS compliant

### 3. Specifications

- Form Factor : PICMG 1.3
- CPU Supported : LGA1155 Intel® Core™ i7/i5/i3/Pentium®/Celeron® CPU
- PCH : Intel® Q67
- Memory : Two 240-pin 1333/1066 MHz dual-channel unbuffered DDR3 SDRAM DIMMs support (system max. 16.0 GB)
- Graphics Engine : Supports DirectX 10.1 and OpenGL 3.0  
Full MPEG2, VC1, AVC Decode
- Audio : Supports IEI AC-KIT-888HD audio kit
- BIOS : UEFI BIOS
- Ethernet Controllers : Intel® 82583V PCIe Ethernet controller  
Intel® 82579 PHY with Intel® AMT 7.0 support (LAN2)
- Super I/O Controller : Fintek F81866
- Watchdog Timer : Software programmable supports 1~255 sec. system reset
- Expansion : One PCIe Mini slot (with USB 2.0/1.1 signal)  
PCIe signal and PCI signal via golden fingers  
Supports PCIe x1\* or x4\*\* slots on backplane  
\* The BIOS version “B202ARxx.bin” is used for “PCIe x1 signal to four PCIe x1 slots”, such as the IEI PE-5S2-R40 backplane.  
\*\* The BIOS version “V0V2ARxx.bin” is used for “PCIe x4 signal to one PCIe x4 slot”, such as the IEI PE-5S-R40 backplane.
- I/O Interface Connectors :
  - Audio Connector : One internal audio connector (10-pin header)
  - Digital I/O : 8-bit, 4-bit input/4-bit output
  - Display Output : One VGA integrated in the Intel® Q67(rear I/O)  
One DVI-D integrated in the Intel® Q67 (via 26-pin header to the DVI-D/USB kit; DVI model only)
  - Ethernet : Two RJ-45 GbE ports
  - Fan : One 4-pin wafer connector
  - FDD : One 34-pin floppy disk drive connector
  - Front Panel : One 14-pin header (power LED, HDD LED, speaker, power button, reset button)
  - I2C : One 4-pin wafer connector
  - Infrared : One via 5-pin header
  - Keyboard/Mouse : One 6-pin wafer connector
  - Parallel Port : One parallel port via internal 26-pin box header
  - Serial ATA : Four SATA 3Gb/s connectors (support RAID 0, 1, 5, 10)  
Two SATA 6Gb/s connectors (support RAID 0, 1, 5, 10)

- Serial Ports : Two RS-232 via internal box headers  
One RS-422/485 via internal 4-pin wafer connector
- SMBus : One 4-pin wafer connector
- TPM : One via 20-pin header
- USB Ports : Two external USB 2.0 ports on rear IO  
Six internal USB 2.0 ports by three pin headers
- Environmental and Power Specifications :
  - Power Supply : 5V/12V, AT/ATX power supported
  - Power Consumption : 3.3V@1.69A, 5V@3.45A , 12V@0.32A, Vcore@5.24A, 5VSb@0.17(3.40 GHz Intel® Core™ i7 2600 CPU with two 1333 MHz 2GB DDR3 memory)
  - Operating Temperature : -10°C ~ 60°C
  - Humidity :5% ~ 95% (non-condensing)
- Physical Specifications :
  - Dimensions : 338 mm x 126 mm
  - Weight (GW/NW) : 1200 g / 420 g

## 4. Dimensions(mm)

### 4.1 PCIE-Q670 Series Dimensions (mm)

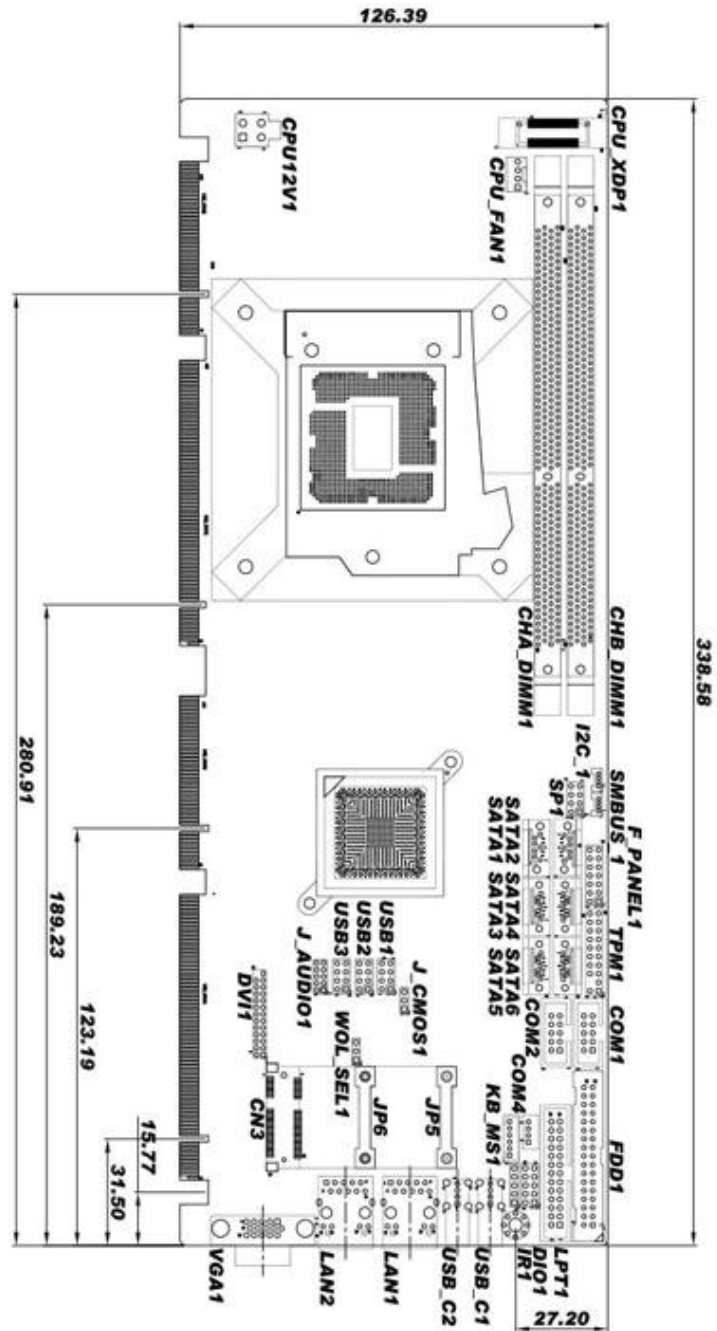

### 4.2 External Interface Panel Dimensions (mm)

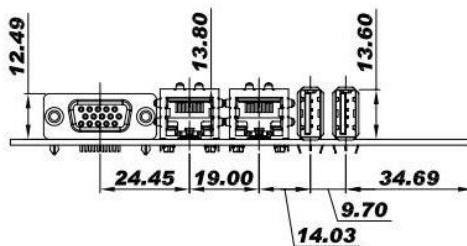

## 5. Jumper and Connector

### 5.1 Jumper and Connector Locations

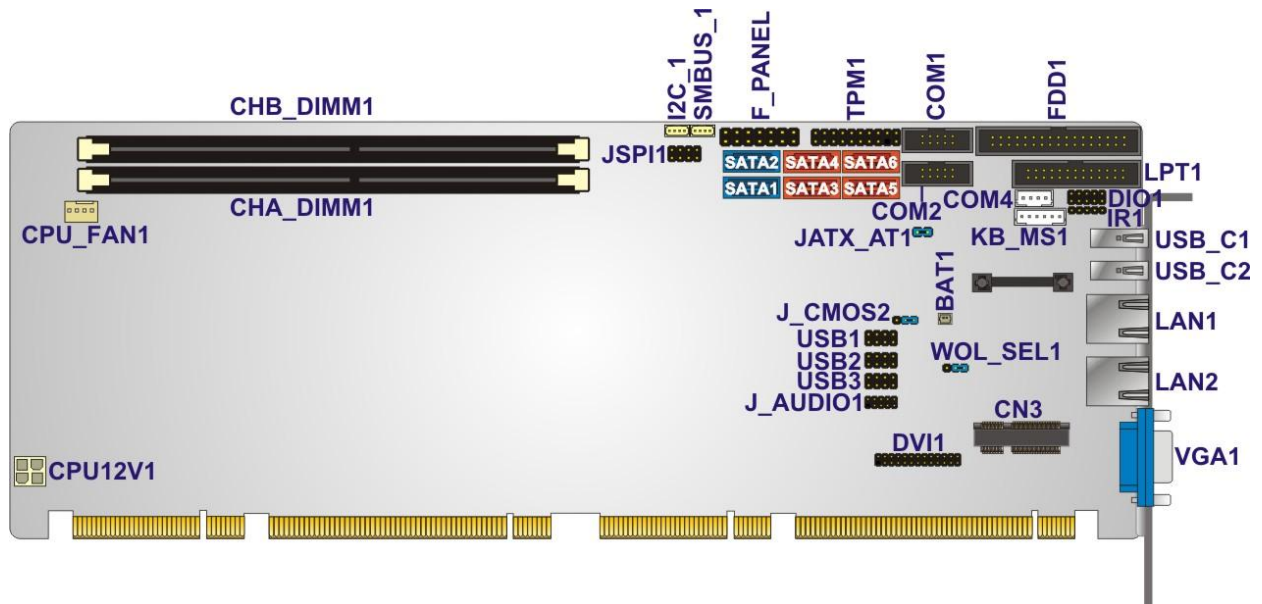



## 5.2 Peripheral Interface Connectors

Connector	Type	Label
+12V ATX power supply connector	4-pin Molex power connector	CPU12V1
Audio kit connector	10-pin header	J_AUDIO1
Battery connector	2-pin wafer	BAT1
DDR3 DIMM sockets	240-pin socket	CHA_DIMM1 CHB_DIMM1
Digital I/O connector	10-pin header	DIO1
DVI-D connector (DVI model only)	26-pin header	DVI1
Fan connector (CPU)	4-pin wafer	CPU_FAN1
Floppy disk drive connector	34-pin box header	FDD1
Front panel connector	14-pin header	F_PANEL1
I2C connector	4-pin wafer	I2C_1
Infrared connector	5-pin header	IR1
Keyboard and mouse connector	6-pin wafer	KB_MS1
Parallel port connector	26-pin box header	LPT1
PCIe Mini slot	PCIe Mini	CN3
SATA 3Gb/s drive connector	7-pin SATA connector	SATA3, SATA4, SATA5, SATA6
SATA 6Gb/s drive connector	7-pin SATA connector	SATA1, SATA2
Serial port, RS-422/485	4-pin wafer	COM4
Serial port, RS-232	10-pin box header	COM1, COM2
SMBus connector	4-pin wafer	SMBUS_1
SPI ROM connector	8-pin header	JSPI1
TPM connector	20-pin header	TPM1
USB connectors	8-pin header	USB1, USB2, USB3

## 5.3 External Interface Panel Connectors

Connector	Type	Label
Ethernet connector	RJ-45	LAN1
Ethernet connector	RJ-45	LAN2
USB port	USB	USB_C1
USB port	USB	USB_C2
VGA connector	15-pin female	VGA1

## 6. Connector and Jumper setting

### 6.1 Internal Peripheral Connectors

#### 6.1.1 12V Power Connector (CPU12V1)

The connector supports the 12V power supply.

Pin	Description	Pin	Description
1	GND	2	GND
3	+12V	4	+12V

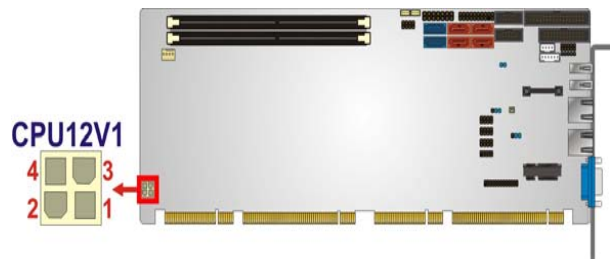

#### 6.1.2 Audio Kit Connector (J\_AUDIO1)

This connector connects to an external audio kit.

Pin	Description	Pin	Description
1	ACZ_SYNC	2	ACZ_BITCLK
3	ACZ_SDOUT	4	ACZ_PCBEPP
5	ACZ_SDIN	6	ACZ_RST#
7	ACZ_VCC	8	ACZ_GND
9	ACZ_12V	10	ACZ_GND

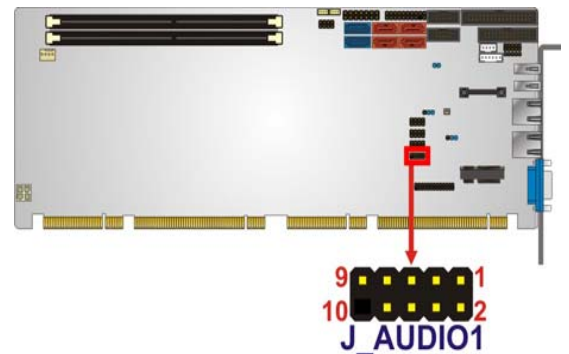

#### 6.1.3 Battery Connector (BAT1)

This is connected to the system battery. The battery provides power to the system clock to retain the time when power is turned off.

Pin	Description
1	GND
2	Battery+

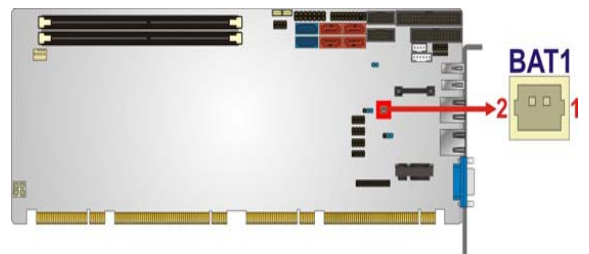

#### 6.1.4 DDR3 DIMM Slots (CHA\_DIMM1, CHB\_DIMM1)

The DIMM slots are for DDR3 DIMM memory modules.

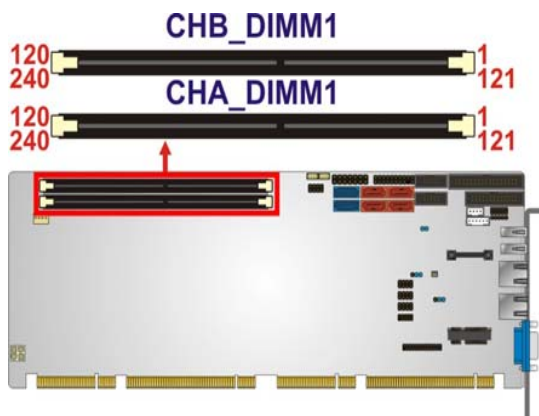

### 6.1.5 Digital I/O Connector (DIO1)

The digital I/O connector provides programmable input and output for external devices.

The digital I/O provides 4-bit output and 4-bit input.

Pin	Description	Pin	Description
1	GND	2	VCC
3	Output 3	4	Output 2
5	Output 1	6	Output 0
7	Input 3	8	Input 2
9	Input 1	10	Input 0

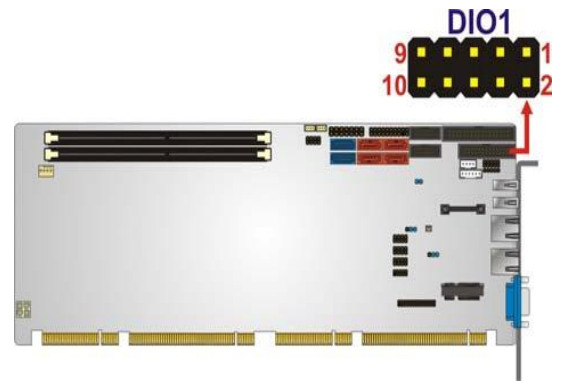

### 6.1.6 DVI-D Connector (DVI Model Only) (DVI1)

The DVI-D connector connects to a monitor that supports DVI video input via the DVI-D/USB kit.

Pin	Description	Pin	Description
1	Data 2	2	Data 2+
3	GND	4	NC
5	NC	6	DDC Clock
7	DDC Data	8	NC
9	Data 1	10	Data 1+
11	GND	12	NC
13	NC	14	VCC
15	GND	16	Hot Plug Detect
17	Data 0	18	Data 0+
19	GND	20	NC
21	NC	22	GND
23	Clock +	24	Clock
25	GND	26	NC

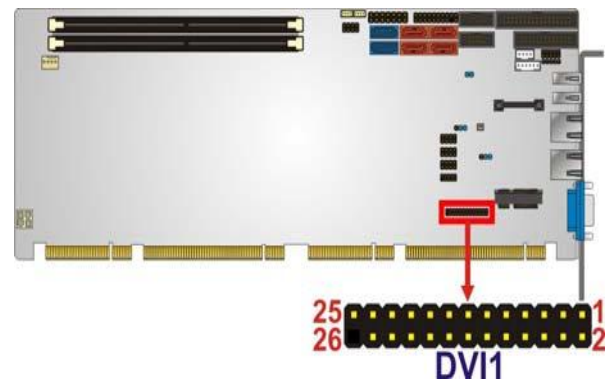

### 6.1.7 Fan Connector (CPU) (CPU\_FAN1)

The fan connector attaches to a CPU cooling fan.

Pin	Description
1	GND
2	+12 V
3	Rotation Signal
4	PWM Control Signal

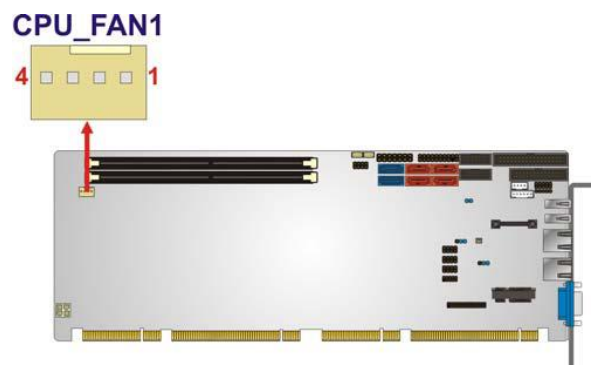

### 6.1.8 Floppy Disk Drive Connector (FDD1)

The floppy disk drive connector is connected to a floppy disk drive.

Pin	Description	Pin	Description
1	GND	2	REDUCE WRITE
3	GND	4	NC
5	NC	6	NC
7	GND	8	INDEX#
9	GND	10	MOTOR ENABLE A#
11	GND	12	DRIVE SELECT B#
13	GND	14	DRIVE SELECT A#
15	GND	16	MOTOR ENABLE B#
17	GND	18	DIRECTION#
19	GND	20	STEP#
21	GND	22	WRITE DATA#
23	GND	24	WRITE GATE#
25	GND	26	TRACK 0#
27	GND	28	WRITE PROTECT#
29	GND	30	READ DATA#
31	GND	32	SIDE 1 SELECT#
33	GND	34	DISK CHANGE#

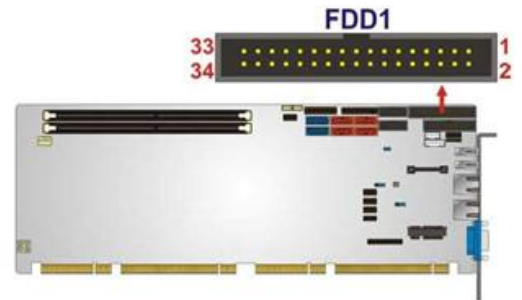

### 6.1.9 Front Panel Connector (F\_PANEL1)

The front panel connector connects to the indicator LEDs and buttons on the computer's front panel.

Function	Pin	Description	Function	Pin	Description
Power LED	1	+5V	Speaker	2	+5V
	3	N/C		4	N/C
	5	GROUND		6	N/C
Power Button	7	PWR_BTN+		8	Speaker
	9	PWR_BTN-	Reset	10	N/C
HDD LED	11	+5V		12	RESET
	13	HDD_LED-		14	GROUND

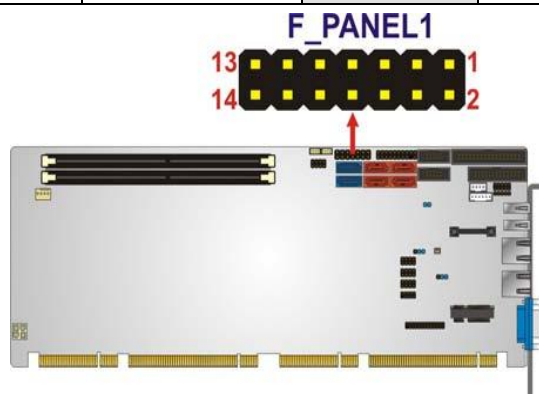

### 6.1.10 I2C Connector (I2C\_1)

The I2C connector is for system debug.

Pin	Description
1	GND
2	PCH_GP38_PU
3	PCH_GP39_PU
4	+5VS

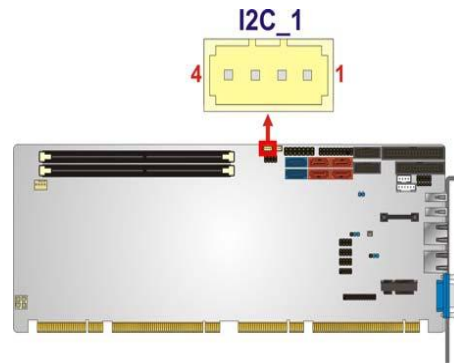

### 6.1.11 Infrared Interface Connector (IR1 CN)

The infrared connector attaches to an infrared receiver for use with remote controls.

Pin	Description
1	VCC
2	NC
3	IR-RX
4	GND
5	IR-TX

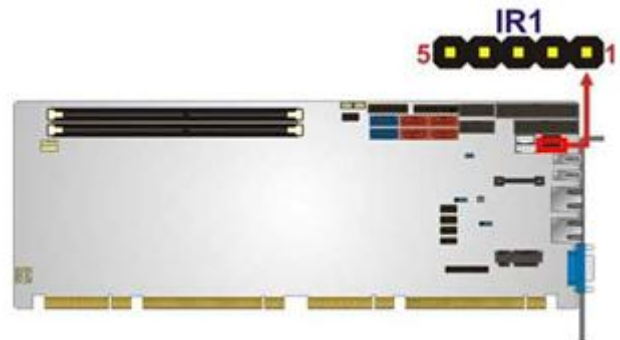

### 6.1.12 Keyboard/Mouse Connector (KB\_MS1)

The keyboard/mouse connector connects to a PS/2 Y-cable that can be connected to a PS/2 keyboard and mouse.

Pin	Description
1	+5 VCC
2	Mouse Data
3	Mouse Clock
4	Keyboard Data
5	Keyboard Clock
6	GROUND

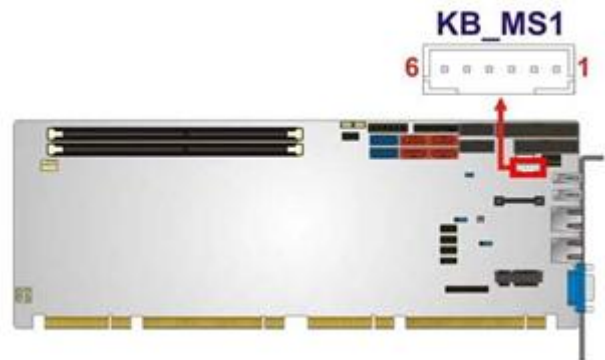

### 6.1.13 Parallel Port Connector (LPT1)

The parallel port connector connects to a parallel port connector interface or some other parallel port device such as a printer.

Pin	Description	Pin	Description
1	STROBE#	2	DATA0
3	DATA1	4	DATA2
5	DATA3	6	DATA4
7	DATA5	8	DATA6
9	DATA7	10	ACKNOWLEDGE#
11	BUSY	12	PAPER EMPTY
13	PRINTER SELECT	14	AUTO FORM FEED #
15	ERROR#	16	INITIALIZE#
17	PRINTER SELECT LN#	18	GND
19	GND	20	GND
21	GND	22	GND
23	GND	24	GND
25	GND		

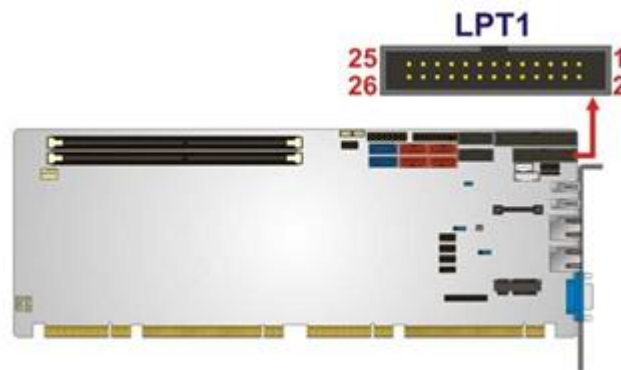

### 6.1.14 PCIe Mini Card Slot(CN3)

The PCIe Mini card slot is for installing a PCIe Mini expansion card.

Pin	Description	Pin	Description
1	PCIE_WAKE#	2	VCC3
3	NC	4	GND
5	NC	6	1.5V
7	CLKREQ#	8	LFRAME#
9	GND	10	LAD3
11	CLK	12	LAD2
13	CLK+	14	LAD1
15	GND	16	LAD0
17	PCIRST#	18	GND
19	LPC	20	VCC3
21	GND	22	PCIRST#
23	PERN2	24	3VDual
25	PERP2	26	GND
27	GND	28	1.5V
29	GND	30	SMBCLK
31	PETN2	32	SMBDATA
33	PETP2	34	GND
35	GND	36	USBD
37	NC	38	USBD+
39	NC	40	GND
41	NC	42	NC
43	NC	44	RF_LINK#
45	NC	46	BLUELED#
47	NC	48	1.5V
49	NC	50	GND
51	NC	52	VCC3

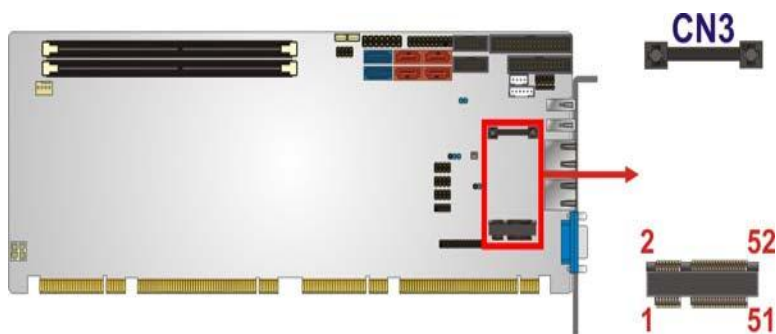

### 6.1.15 SATA 3Gb/s Drive Connectors (SATA3, SATA4, SATA5, SATA6)

The SATA drive connectors can be connected to SATA drives and support up to 3Gb/s data transfer rate.

Pin	Description	Pin	Description
1	GND	2	TX+
3	TX	4	GND
5	RX	6	RX+
7	GND		

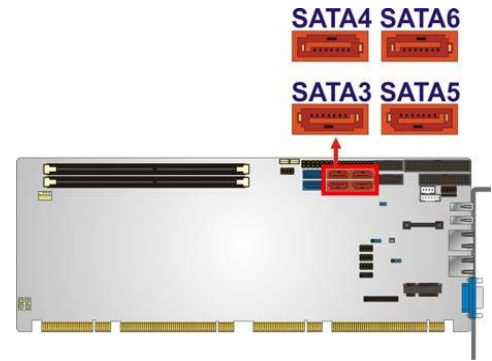

### 6.1.16 SATA 6Gb/s Drive Connector(SATA1, SATA2)

The SATA drive connectors can be connected to SATA drives and support up to 6Gb/s data transfer rate.

Pin	Description	Pin	Description
1	GND	2	TX+
3	TX	4	GND
5	RX	6	RX+
7	GND		

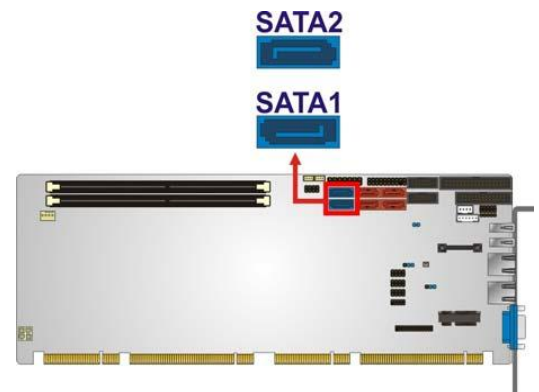

### 6.1.17 Serial Port Connectors, RS-232(COM1, COM2)

Each of these connectors provides RS-232 connections.

Pin	Description	Pin	Description
1	Data Carrier Direct (DCD)	2	Receive Data (RXD)
3	Transmit Data (TXD)	4	Data Terminal Ready (DTR)
5	Ground (GND)	6	Data Set Ready (DSR)
7	Request To Send (RTS)	8	Clear To Send (CTS)
9	Ring Indicator (RI)	10	N/C

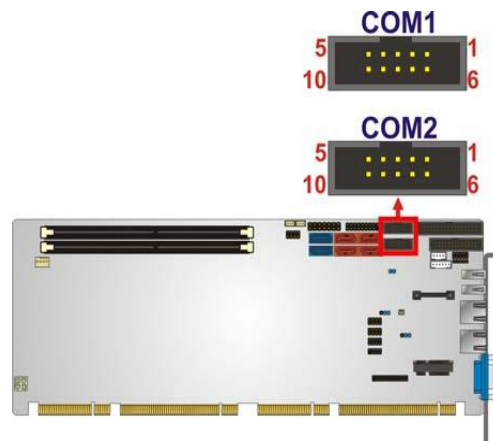



### 6.1.18 Serial Port Connector, RS-422/485 (COM4)

This connector provides RS-422 or RS-485 communications.

Pin	Description	Pin	Description
1	RXD485#	3	RXD485
2	RXD485+	4	RXD485#

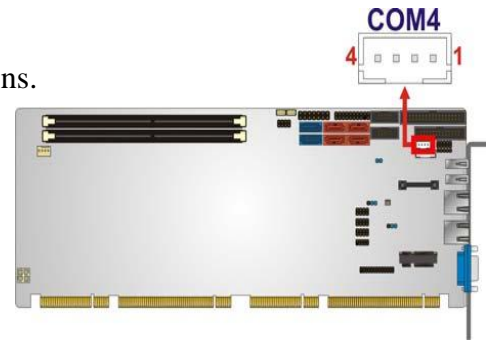

### 6.1.19 SMBus Connector (SMBUS\_1)

The SMBus (System Management Bus) connector provides low-speed system management communications.

Pin	Description
1	GND
2	SMB_DATA
3	SMB_CLK
4	+V5S

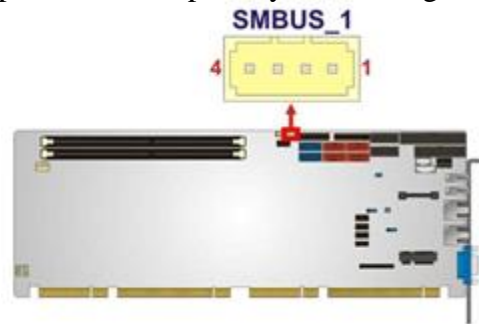

### 6.1.20 SPI ROM Connector (JSPI1)

The SPI connector is used to flash the BIOS.

Pin	Description	Pin	Description
1	+3.3V	2	GND
3	SPI_CS0	4	SPI_CLK
5	SPI_SO0	6	SPI_SI
7	NC	8	NC

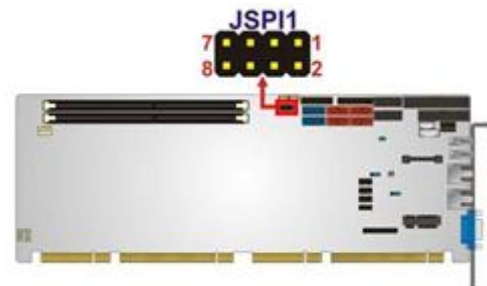

### 6.1.21 TPM Connector (TPM1)

The TPM connector connects to a TPM module.

Pin	Description	Pin	Description
1	CLK	2	GND
3	ERAME#	4	NC
5	RESRT#	6	+5V
7	AD3	8	AD2
9	+3V	10	AD1
11	AD0	12	GND
13	SMB_CLK	14	SMB_DATA
15	SB3V	16	SERIRQ
17	GND	18	CLKRUN#
19	PM_SUS_STAT#	20	DRQ#

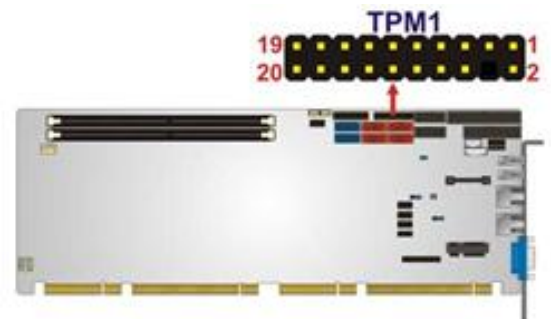

### 6.1.22 USB Connectors (USB1, USB2, USB3)

The USB connectors connect to USB devices. Each pin header provides two USB ports.

Pin	Description	Pin	Description
1	VCC	2	GND
3	DATA-	4	DATA+
5	DATA+	6	DATA-
7	GND	8	VCC

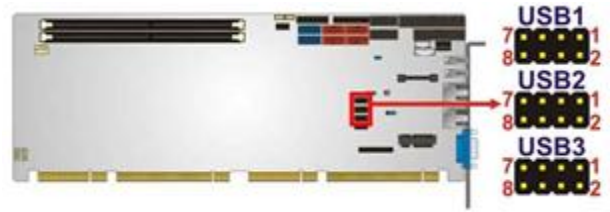

### 6.2 External Peripheral Interface Connector Panel

The figure below shows the external peripheral interface connector (EPIC) panel. The EPIC panel consists of the following:

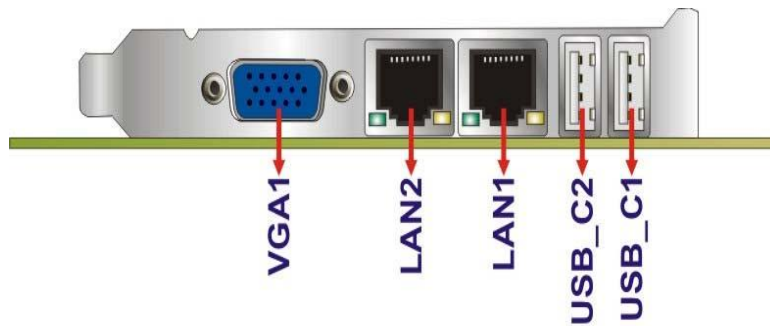

#### 6.2.1 Ethernet Connectors (LAN1 and LAN2)

The PCIE-Q670 Series is equipped with two built-in RJ-45 Ethernet controllers. Each controller can connect to the LAN through one RJ-45 LAN connector.

Pin	Description	Pin	Description
1	MDIA3	2	MDIA3+
3	MDIA2	4	MDIA1
5	MDIA1+	6	MDIA2+
7	MDIA0	8	MDIA0+

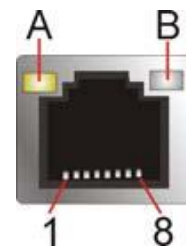

LED	Description	LED	Description
A	on: linked blinking: data is being sent/received	B	off: 10 Mb/s green: 100 Mb/s orange: 1000 Mb/s

### 6.2.2 USB Connectors (USB\_C1 and USB\_C2)

The PCIE-Q670 Series has two external USB 2.0 ports. The ports connect to both USB 2.0 and USB 1.1 devices.

Pin	Description
1	VCC
2	DATA-
3	DATA+
4	GROUND

### 6.2.3 VGA Connector (VGA1)

The VGA connector connects to a monitor that accepts a standard VGA input.

Pin	Description	Pin	Description
1	RED	2	GREEN
3	BLUE	4	NC
5	GND	6	GND
7	GND	8	GND
9	VGAVCC	10	GND
11	NC	12	DDCDAT
13	HSYNC	14	VSYNC
15	DDCCLK		

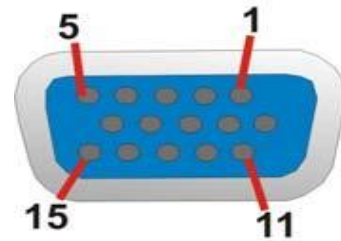

## 7. **Ordering Information**

<u>PRODUCT</u>	<u>DESCRIPTIONS</u>
JD50PCIEQ670	Full-Size PICMG 1.3 CPU Card Supports 32nm LGA1155 Intel® Core™ i7/i5/i3/Pentium® /Celeron® CPU, Intel® Q67 Chipset, DDR3, VGA/DVI-D, Dual Intel® PCIe GbE, Two SATA 6Gb/s Ports, PCIe Mini, HD Audio and RoHS