



musikelectronic geithain

RL 944K

RL 944K1



Instructions for installation and use

Table of contents

1	Introduction	3
2	System description	4
3	Basic information	5
3.1	Guidelines	5
3.2	Safety instructions	5
3.3	Unboxing	6
3.4	Delivery contents	6
3.5	Cleaning	6
3.6	Environmental conditions	6
3.7	Guarantee acknowledgements	6
4	Positioning	7
4.1	Positioning near walls	7
4.2	Stereo operation	8
4.3	Surround operation	9
5	Connecting the speakers	10
5.1	Set-up the RL944K	10
5.2	Set-up the RL944K1	10
5.3	Cable connection	11
5.4	Status indication	11
5.5	Adjustment controller	11
6	Specifications	12
7	Acoustic measurements	14
8	Notes	15

1 Introduction

Dear customer,

Thank you for your trust you have put in us by buying these speakers. You decided upon a quality product that in regard to tonal and technical characteristics complies to the utmost expectations.

The usual burn-in period is not required, because the speakers are artificially aged in-house.

Please read the technical description and manual to take advantage of the capabilities of these speakers and ensure safe operation.

2 System description

The RL944K is a specialist for small rooms and short listening distances. So it is designed for both the professional user in the outside broadcasting van, small audio, video and film studios and for the discerning music enthusiast, who is not willing to make a compromise in a small living room.

By the cardioid radiation characteristics within the frequency range from 35 through 250Hz the reflections on the back walls behind the speaker can be minimised. In addition the transfer characteristic can be matched to the acoustical conditions of the reproduction room as well as to the set-up situation by an integrated room matching filter.

The total directivity index of the monitor was optimised for listening distances between 1 and 2.60 m (3.3 and 8.6 ft). As the bass system a very linear 200 mm (8") long throw driver in a cardioid cabinet is employed, delivering excellent impulse fidelity. Due to the special construction a low frequency reproduction is possible that is not expected from such a small cabinet. Therefore the RL944K is a real full-range speaker and in an outside broadcasting van an additional subwoofer can be spared. The 100 mm (4") cone is mounted together with the 19 mm (3/4") dome tweeter coaxially in front of the bass system allowing a precise steering of the focal perspective. As a result a realistic and steady spatial performance of the sound image around the listening position is achieved, with high homogeneity and smallest possible colouration. By the great consequent optimisation for short listening distances the RL944K allows realistic depth arrangement even in outside broadcasting vans and facilitates correct miking. Therefore the RL944K is a precision studio tool allowing fatigue free working for hours.

The three-channel MOSFET power amplifier with electronic crossover is integrated within the back wall of the cabinet and is hinged for service purposes. An intermittent LED lighting signals when the overload limit is reached. After crossing of the maximum level the output level will be reduced by 20dB to avoid any overloading of the components.

The RL944K1 is a more compact cabinet variant of the RL944K, that is employed when not enough room is available. Be it a video wall or an outside broadcasting van. As an alternative to the standardly provided MOSFET amplifier in an upright standing enclosure the 19" compatible Class D amplifier RL-Amplifier is also available.

A variety of special stands and racks is available as accessories. According fixing elements have been integrated into the loudspeaker cabinet.

3 Basic information

3.1 Guidelines

This product complies to requirements of current European and national guidelines (Elektromagnetische Verträglichkeit 89/336/EWG). The conformity is ascertained, corresponding declarations and records are deposited with the manufacturer.

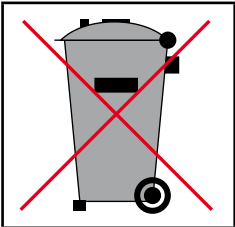

Products built by us belong to B2C-class of the WEEE guidelines and must not be disposed with domestic waste.

3.2 Safety instructions

Like using any other electrical device you should observe the following operation guidelines, safety instructions and warning signs to ensure optimum functionality and safety of operation!

- ⚡ Read these instructions carefully.
- ⚡ Keep these instructions.
- ⚡ Do not attempt to service this product yourself as opening or removing cover may expose you to dangerous voltage or other hazards.
- ⚡ Electrical devices are not intended for use by kids.
- ⚡ Operate this device only with the mains voltage stated on the backside.
- ⚡ Do not install the device near any heat sources.
- ⚡ Do not expose the device to direct sun radiation.
- ⚡ Do not install the device in rooms with high humidity.
- ⚡ Ensure sufficient air ventilation when installing the device in a shelf or wall.
- ⚡ Do not try to insert anything into device openings.
- ⚡ The device shall not be exposed to dripping or splashing and no objects filled with liquids shall be placed on the device.
- ⚡ There is risk of electric shock when the device is open.
- ⚡ Refer all servicing to qualified service personnel.
- ⚡ Clean only with dry or slightly moistened cloth.

3.3 Unboxing

Unpack the speaker carefully and check for visible damages by inappropriate transport. In case of damages report them to your retailer. Keep the packaging, in case the speaker has to be transported in the future.

3.4 Delivery contents

- ◄ Speaker
- ◄ Amplifier enclosure (only RL944K1)
- ◄ Speakon cable (only RL944K1)
- ◄ Mains cable
- ◄ Technical description and user manual

3.5 Cleaning

The speaker is made of real wood veneer and should be nurtured in the same way as furnishings. We advice quality wax polish to ensure durability of the veneer. Surfaces can also be cleaned with tidy, slightly dampened, fuzz-free, smooth cloth.

3.6 Environmental conditions

Ensure the following environmental conditions:

Operating temperature + 15°C ... + 35°C

Storage temperature range - 25°C ... + 45°C

Relative humidity 45% ... 75%

3.7 Guarantee acknowledgements

Opening the device by unauthorised personnel leads to all claims under guarantee expire. In case of destruction by overload, misuse or outside influences there are no claims under guarantee.

4 Positioning

Our speakers do not impose special requirements neither in stereo nor in multichannel set-ups. Nonetheless speaker positioning has influence on listening impression because every room is individually designed and furnished. The following advices are just guidelines that ease proper positioning. In addition we offer a measurement service to take advantage of the capabilities of your listening environment.

4.1 Positioning near walls

When speakers are installed near walls sound quality is physically affected. Every customary speaker behaves as a punctual sonic source in the low frequency range, with sonic waves spherical radiated without any constructional measures. Back wall reflections are unavoidable.

The speakers however utilise cardioid radiation characteristics with rearward attenuation greater than 10dB. Because of this structural measurement installation near walls is considerably less critical. For optimum listening experience a minimum distance of 20 cm (7.9") to walls and furniture should be ensured. Avoid corner installations because unwanted bass accentuation could arise.

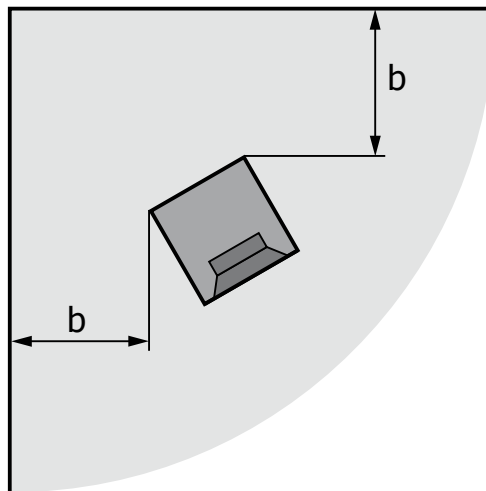

◀ Minimum distance to wall

$$b \geq 20 \text{ cm (7.9")}$$

4.2 Stereo operation

The optimum position of the speakers in your listening environment is the so-called stereo triangle (see figure). The base distance between the speakers and the distance to the hearing zone form an equilateral triangle (stereo triangle). A distance less than 1 m (3.3 ft) or more than 2.6 m (8.6 ft) should be avoided. For precise, spacial reproduction turn the speakers inside, directed to the hearing zone.

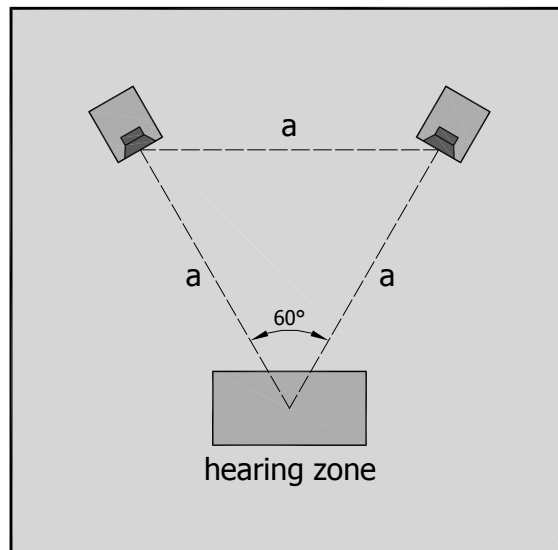

- ◀ Distance between speakers and your listening position $a = 1 \dots 2.6 \text{ m (3.3 ... 8.6 ft)}$
- ◀ Adjust the speaker horizontally to the height of the ear at the listening position

4.3 Surround operation

In surround operation the stereo triangle (see Stereo operation) is extended to a circle. The hearing zone is the center of this circle. Position all speakers in the same distance to the hearing zone. The center speaker is positioned in the middle between both front speakers. Pay attention to positioning the front and rear speakers horizontally along one plane. The angle between center and rear speakers should be about $110^\circ - 120^\circ$.

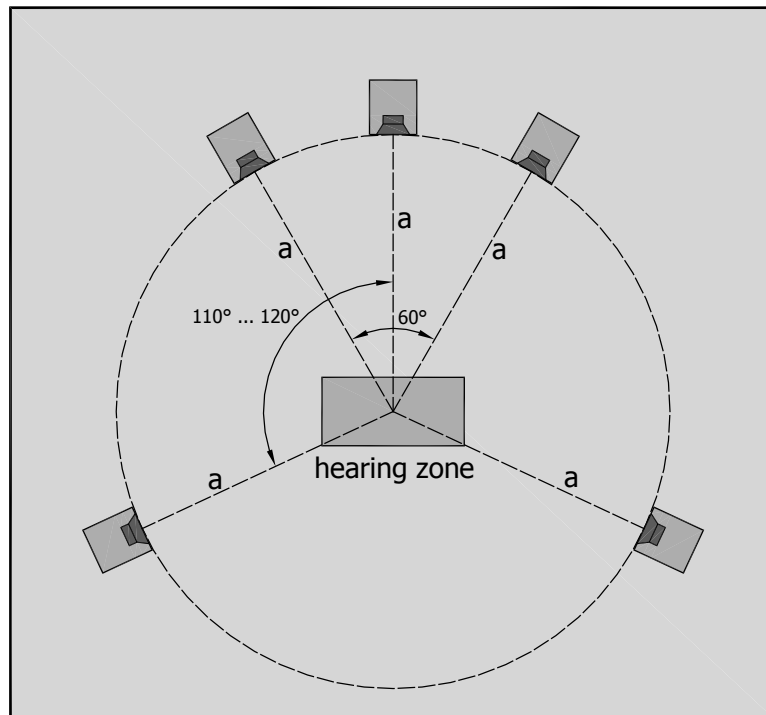

- ◀ Distance between speakers and your listening position $a = 1 \dots 2.6 \text{ m (3.3 \dots 8.6 ft)}$

5 Connecting the speakers

In this chapter we inform you how to connect your speakers to mains and your signal source. Ensure that the mains switch on the backside is in position "OFF". Only when your speaker is completely connected (see chapters 5.1, 5.2 and 5.3) you can take the device into operation by use of the mains switch.

5.1 Set-up the RL944K

Check the mains voltage stated on the backside of the device. If your local mains voltage does not match the specification of the speaker, please refer to your retailer or direct distribution. When the stated and your local mains voltage comply connect the mains connector of the speaker to the socket with the included mains cable. Connect your signal source with the amplifier through the XLR socket.

5.2 Set-up the RL944K1

The amplifier of the RL944K1 is housed in a separate enclosure. Every amplifier is paired to exactly one speaker by the same serial number. Ensure installation in pairs.

Before start-up check the mains voltage stated on the backside of the device. If your local mains voltage does not match the specification of the speaker, please refer to your retailer or direct distribution. When the stated and your local mains voltage comply connect the mains connector of the speaker to the socket with the included mains cable.

Now connect the Speaker to the amplifier with the shielded Speakon cable that is part of the delivery contents. Ensure that the latch snaps in place in the sockets of the speaker and the amplifier by turning the plug clockwise. Connect your signal source with the amplifier through the XLR socket.

5.3 Cable connection

The input of the integrated amplifier is electrically balanced. When your signal source also utilises balanced connectors, please use a cable wired as stated in the table:

	Balanced connector (amplifier)	Balanced connector (signal source)	Unbalanced connector (Signal source)
	XLR	XLR	RCA
Erde	Pin 1	Pin 1	Ring
Signal +	Pin 2	Pin 2	Tip
Signal -	Pin 3	Pin 3	Ring

When using a signal source with unbalanced outputs (RCA) you need to balance the connecting cables. This avoids hum and other noise interferences. The table and the following figure show the wiring.

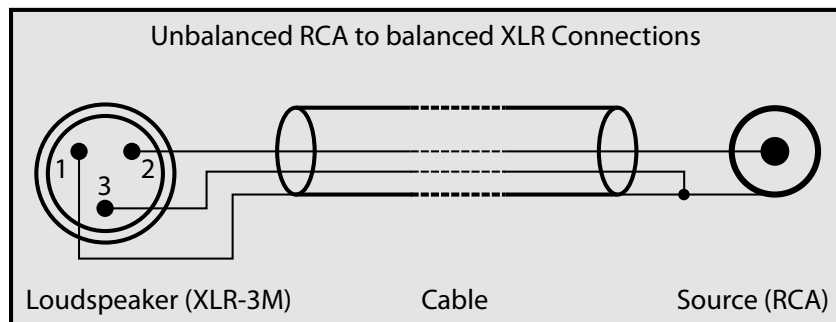

To carry the signal connect the XLR socket of the speaker to your signal source.

5.4 Status indication

The two-coloured LED at the front of the speaker is used as status indicator of the device.

- ◀ LED green indicates normal operation of the device
- ◀ LED red indicates the operation of the overload protection circuit;
Output power limitation to protect the components from overloading

5.5 Adjustment controller

The "Level" controller is used for level adjustment over the full frequency range.

6 Specifications

General	Active 3-way coaxial loudspeaker for listening distances between 1 m and 2.60 m (3.3 ft and 8.6 ft)
Maximum SPL from 100 Hz ... 6 kHz	110 ... 113 dB / r = 1 m (3.3 ft)
Bandwidth	35 Hz ... 20 kHz \pm 3 dB
Calibration: Acoustic output level / $P_E = -14$ dBu	89 dB / r = 1 m (3.3 ft)
Directivity Index from 100 Hz ... 10 kHz	Increasing from 2 to 10 dB
Inherent noise sound level	\leq 7 dB(A) / r = 1 m (3.3 ft)
Total harmonic distortion measured at 96 dB / r = 1 m (3.3 ft) from 100 Hz ... 10 kHz	\leq -40 dB
Nominal input level	+ 6 dBu adjustable
Input impedance	\geq 10 kOhm RC balanced
Electronic crossover frequencies	800 Hz and 3.8 kHz
Nominal output power amplifier	
LF	180 W / 4 Ohm
MF	100 W / 4 Ohm
HF	100 W / 4 Ohm
Input connector	XLR3F
Loudspeaker systems	
Woofers	200 mm (8") cone
Mid-range unit	100 mm (4") cone
Tweeter	19 mm (3/4") dome
Operation and clipping indicator	LED on front side
Power requirements	230 V \sim \pm 10 %, 50 ... 60 Hz 115 V \sim \pm 10 %, 50 ... 60 Hz (Optional) 100 V \sim \pm 10 %, 50 ... 60 Hz (Optional)
Power consumption	Max. 300 VA at full load
Mains connection	IEC power connector
Temperature requirements	
for use	+ 15°C ... + 35°C
for storage	- 25°C ... + 45°C
humidity	45 % ... 75 %

RL944K (Amplifier in loudspeaker cabinet)

Dimensions (h x w x d)	481 x 285 x 330 mm (18.9 x 11.2 x 13 inch)
Weight	24 kg (52.9 lbs)
Design of the cabinet	MDF wood in ash black veneered; optional other veneers or colours with holding device; optional without holding device

RL944K1 (Amplifier in separate enclosure)

Connection cable loudspeaker - amplifier enclosure	Speakon NL8 Standard length 3 m (9.9 ft); optional other lengths
Dimensions (h x w x d)	
Loudspeaker	398 x 254 x 245 (15.7 x 10 x 9.6 inch)
Standard amplifier enclosure	475 x 279 x 120 (18.7 x 11 x 4.7 inch) without base plate
Highend amplifier enclosure	495 x 320 x 260 (19.5 x 12.6 x 10.2 inch) with base plate
Weight	
Loudspeaker	11 kg (24 lbs)
Standard amplifier enclosure	11 kg (24 lbs)
Highend amplifier enclosure	12 kg (26 lbs)
Design of the cabinet	
Loudspeaker	MDF wood in ash black veneered; optional other veneers or colours with holding device; optional without holding device
Standard amplifier enclosure	MDF wood with scratch proof structure coating black RAL9005; optional other colours
Highend amplifier enclosure	MDF wood in ash black veneered; optional other veneers or colours

As an alternative to the standardly provided MOSFET amplifier in an upright standing enclosure the 19" compatible Class D amplifier RL-Amplifier is also available. More information is available in the RL-Amplifier brochure.

7 Acoustic measurements

All acoustic measurements are carried out under anechoic conditions with 1 m (3.3ft) distance.

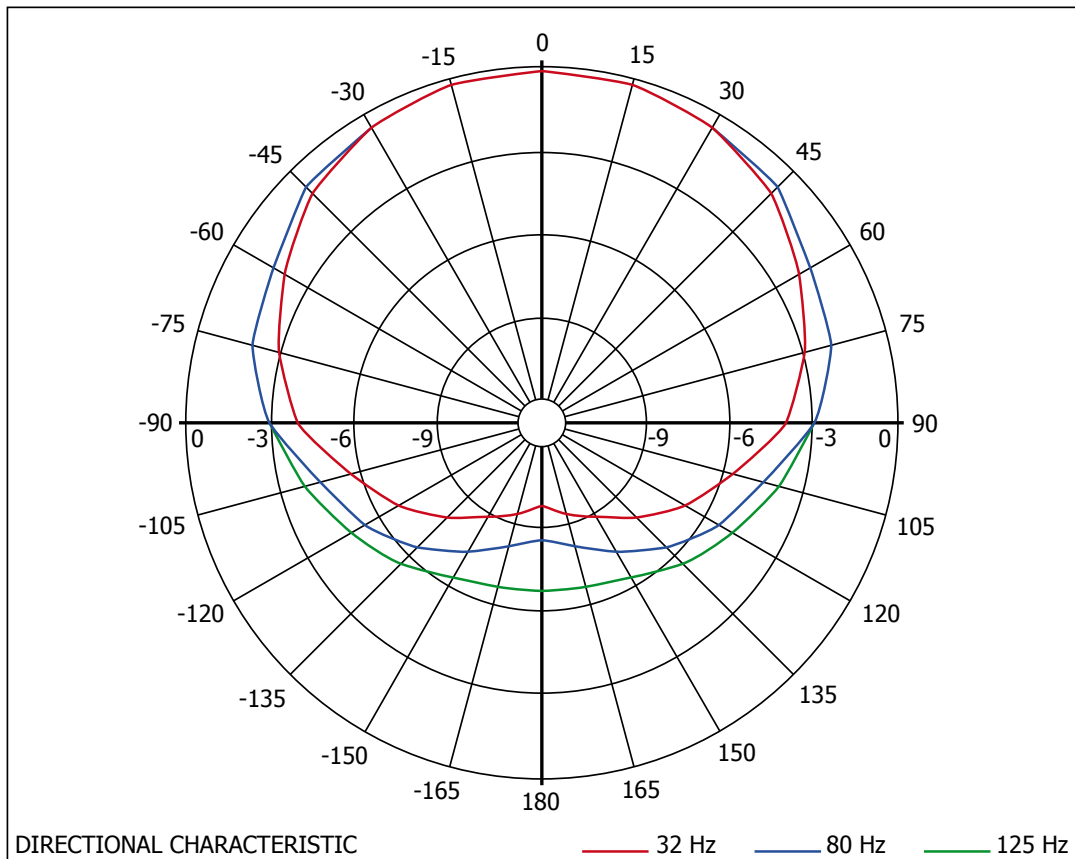
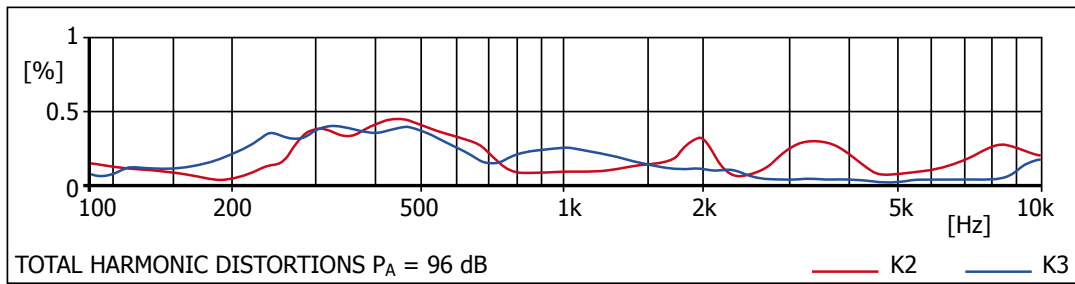
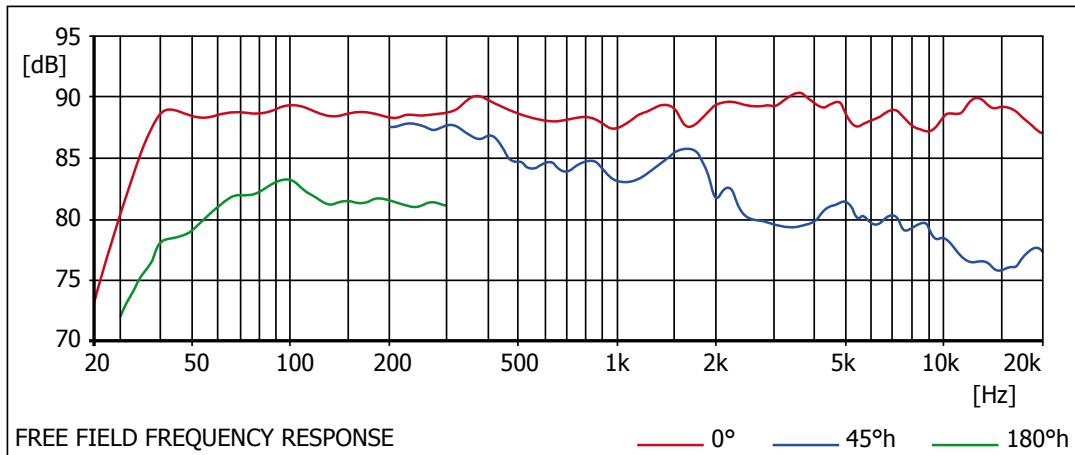

8 Notes

BDARL944KV1150227EN



musikelectronic geithain gmbh

STUDIOTECHNIK - HIGHENDTECHNIK - BESCHALLUNGSTECHNIK

Nikolaistraße 7
04643 Geithain / Germany

Tel: +49 (0) 34341 3110
Fax: +49 (0) 34341 31144

E-Mail: info@me-geithain.de

www.me-geithain.de