

*GPS
Vehicle
Tracker*

User Manual

V5.5

AL900

Table of Contents

1. Working Directions.....	3
2. Specification.....	3
3. GPS Tracker Installation.....	4
3.1. Product Parts List	4
3.2. Precaution before Installation	6
3.3. Installation.....	6
3.4. Wiring Description.....	8
4. Operating Instructions	11
5. SMS Tracking by Mobile.....	14
5.1. Position Report Function.....	15
5.2. Tracking Function.....	15
5.3. Stop tracking function.....	16
6. GPRS Tracking by computer.....	16
6.1.Set APN.....	16
6.2.Set IP and Port.....	17
6.3.Add AL900 to 800D web based tracking software.....	17

1. Working Directions

Thank you for your purchase of AL900 Vehicle GPS Tracker. In order to realize the full functions of this product, please read this manual carefully before starting to use the product.

1.	This product can only be maintained and repaired by qualified professional service personnel. If you detach this product for maintenance or repair, your warranty will be invalidated.
2.	When connecting the other devices, read carefully their instruction manuals, so as to carry out correct installation; do not connect incompatible device.
3.	Please use genuine original parts and qualified batteries and peripheral equipments, so as to avoid damage to this product.
4.	As this product is a high-tech product, please read carefully this manual before starting to use the product, so as to avoid inappropriate operation.
5.	Drivers should not operate this product while driving a vehicle, thereby, affecting safe driving.
6.	This product can work properly only when GSM communication is in good condition.
7.	Please reduce electromagnetic wave interference to the product; and use it properly.
8.	GPS communication is liable to be affected by environmental shielding; may fail to carry out positioning during certain circumstances. It will resume the positioning function as soon as it leaves the shielding environment. This is normal. Please do not worry when encountering such problem.
9.	Each signal sent out from the system will be confirmed for successful transmission in the base station of the mobile operator. However, if system stoppage occurs or if the mobile telephone is preset to a switch off state by the customer, it cannot ensure successful transmission.
10.	For safety reason, do not tell the other people your AL900 mobile number, without taking precautions. Otherwise, your privacy may be compromised along with other safety problem.

2. Specification

Connecting to external GPS antenna, internal SIRF-Star III 20 Channels High Sensitive GPS module
 Four-Band GSM 850/900/1800/1900
 SMS/GPRS communication channels

GPS/GPRS Specification:

SOS Button: Driver can press SOS button for emergency

General: L1 1575.42MHz, C/A code, 20 Parallel Channels

Sensitivity: -143 dBm minimum

Accuracy Position: 10m CEP without S/A

Velocity: 0.1 m/sec without S/A

WAAS Accuracy Position: 5m CEP

Velocity: 0.05m/sec

Acquisition : (1) Cold start: < 60sec average (2) Warm start: < 45sec average (3) Hot start: < 15sec average

Antenna: External GSM and GPS Antenna

Power Specification:

Backup Battery: Built-in Rechargeable Battery

Power Voltage: DC 9V-55V

Environmental Specification:

Operation Temperature: -20°C to +70°C

Storage Temperature:-30°C to +85°C

Operating Humidity: 5% to 95%

3. Wiring Installation

3.1. Product Parts List

<p>GPS Tracker Unit</p>	 <p>A black rectangular GPS vehicle tracker unit with two red LEDs on the front and two black connectors on the back. The text 'GPS Vehicle Tracker AL-900' is printed on the top surface.</p>
<p>GPS Antenna</p>	 <p>A black square GPS antenna with a coiled black cable. The cable has a gold-colored SMA connector at one end and a small black plug at the other.</p>

<p>GSM Antenna</p>	
<p>Car Charger Lighter Socket</p>	
<p>Camera (Optional)</p>	
<p>Door sensor (Optional)</p>	
<p>Fuel sensor (Optional)</p>	

3.2. Precaution before Installation

1	Check if all the parts are included.
2	Prepare a SIM card for GSM communication. Use some other mobile phone to confirm that the PIN code has not been set and that it can dial out and receive telephone calls and SMS without problem.
3	Before install the SIM card; make sure to cut off power from the GPS Tracker unit. The correct installation method is to push the tray completely into the GPS Tracker unit, until you feel it is hooked by something.
4	Find a suitable place inside the car for installing the unit.
5	Check if all the wiring has been connected correctly; then connect the GPS Tracker unit to the power source.

3.3. INSTALLATION

3.3.1 Step 1: Install SIM Card

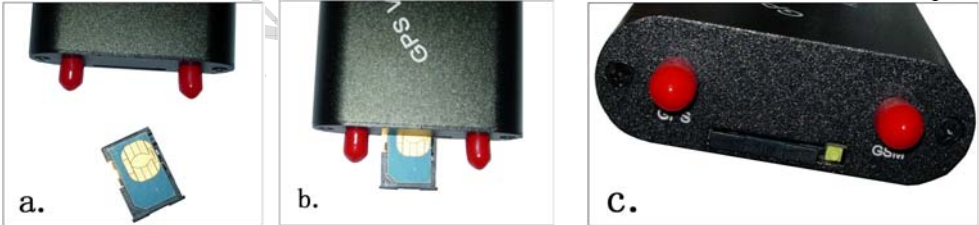
1	Using a speculate object to poke the small button of the SIM card seat, and then it will pop-up a small drawer.
2	Put the SIM card in the drawer, and put back the drawer, as direction shown in the picture. 
3	Make sure to turn off the power before install the SIM card.
4	Make sure to deactivate the PIN code, so that the SIM card can operate without PIN protection.
5	Before install the SIM card to the GPS Tracker, please use a mobile phone to make sure the SIM card can make & receive phone calls without problem.
6	Before install the SIM card to the GPS Tracker, please use a mobile phone to empty the SMS storage of the SIM card.

3.3.2 Step 2: Connect GSM Antenna

1	<p>Connect the GSM Antenna to the unit.</p> 
2	<p>Fasten the connection by turning the screw in the bottom.</p>
3	<p>Please do not swing round the antenna itself.</p>

3.3.3 Step 3: Connect GPS Antenna

1	<p>GPS antenna is used to receive satellite signals in the sky. It should be positioned at a place where it will have an unobstructed view of the sky. The ideal location is top of the dashboard or close to the rear window of the car.</p> 
2	<p>GPS antenna can pick up signals through glass and plastic, but will not "see the sky" through metal or other conductive surfaces. To avoid distractions of GPS signal, make sure the antenna is not covered or shielded by any object containing metal, such as the metallic windshield.</p>
3	<p>If your car is with metallic windshield please cut a hole on the windshield above the place where you put the GPS antenna, so that the antenna can receive the GPS signals.</p>

3.3.4 Turn on the GPS Tracker

Connect the GPS Tracker with 4P cable like below picture, then the AL900 will be automatically turned on



3.3.5 Description of AL900 cables:

AL900 connects to the fuel sensor (picture a,b) , 6pin (picture c,d) and 4pin wires (picture e,f) .

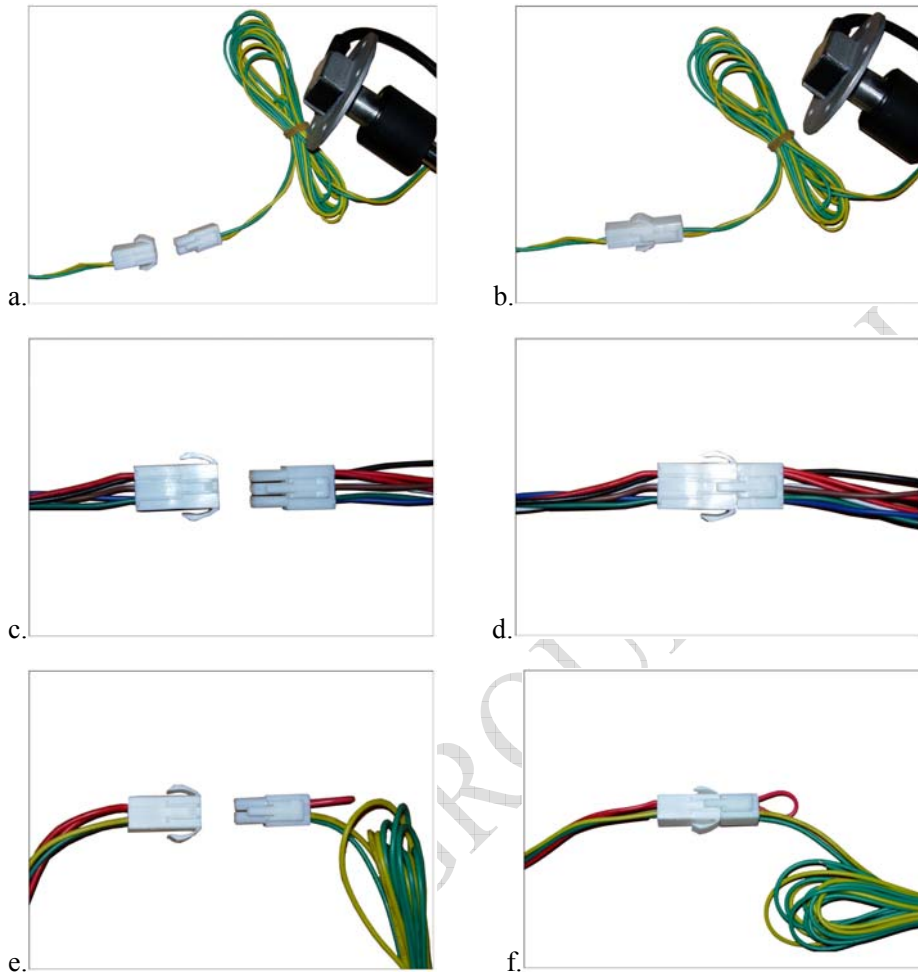

3.4. Wiring Description

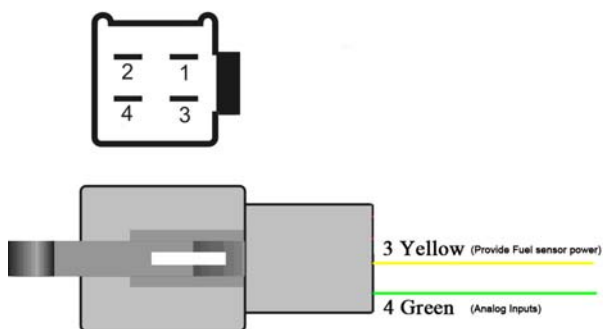

4 pins connector

Pin	Color	function
1	Null	Null
2	Null	Null
3	Yellow	Connect to fuel sensor,Provide Fuel sensor power.
4	Green (AD)	Connect to fuel sensor,10 Bits Resolution Analog Inputs.

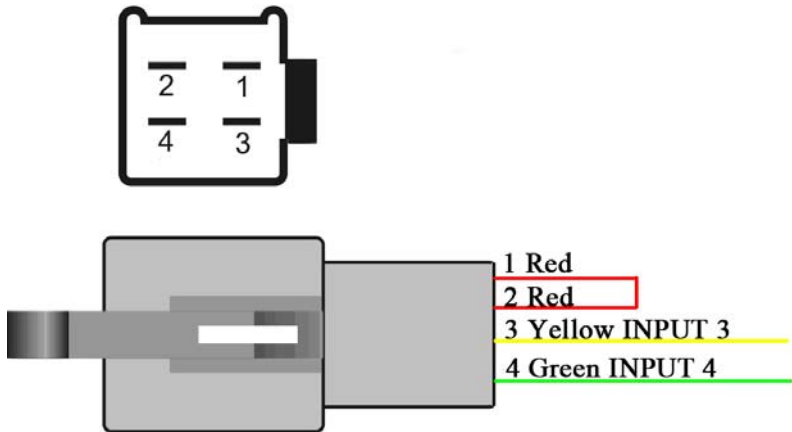

4 pins connector

Pin	Color	function
1	Red (SW1)	SW1 Power switch,when SW1 with SW2 connect,turn on Note: if you need to connect it to other switch, make sure the voltage should not over 4.5V.
2	Red (SW2)	SW2 Power switch,when SW2 with SW1 connect,turn on Note: if you need to connect it to other switch, make sure the voltage should not over 4.5V.
3	Yellow (Input 3)	Connect to door sensor, Negative triggering. <div style="text-align: center;"> </div> <p>a.</p>

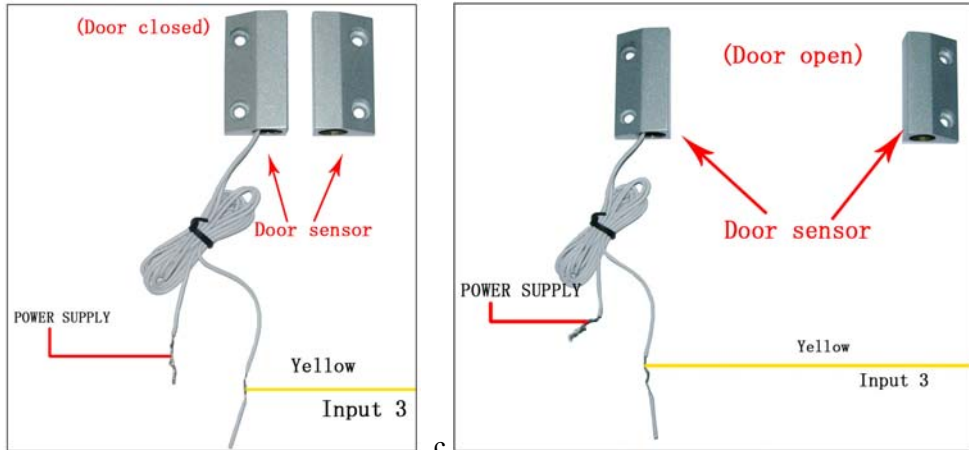
		 <p>b. c.</p> <p>Picture a. Use car Lock Controller Connect and state diagram. Picture b. Door sensor Connect and state diagram (Door closed) Picture c. Door sensor Connect and state diagram (Door open)</p>
4	Green (Input 4)	Connect to shock sensor. Positive triggering. for example you can use it to detect the signal of car shock alarm

A.

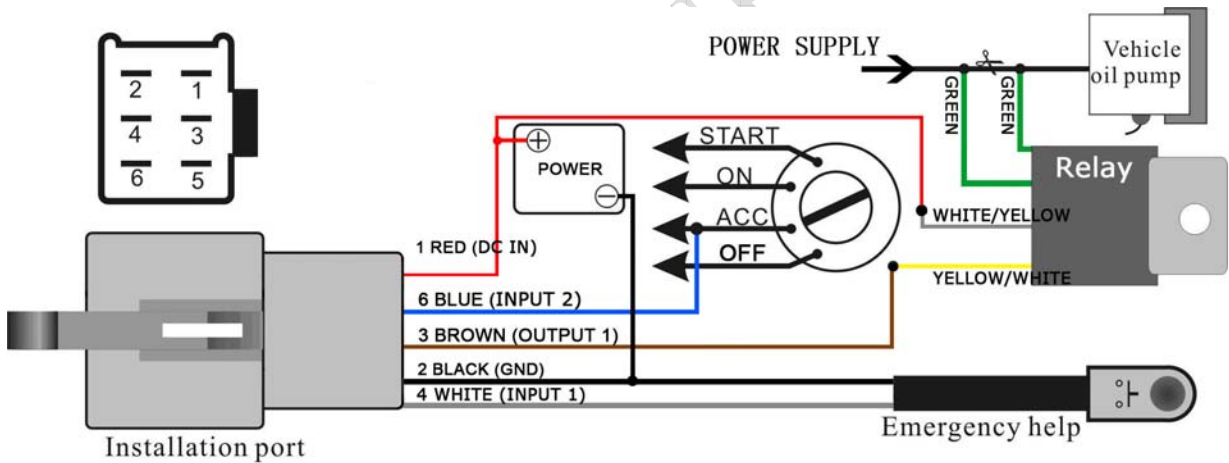

B.

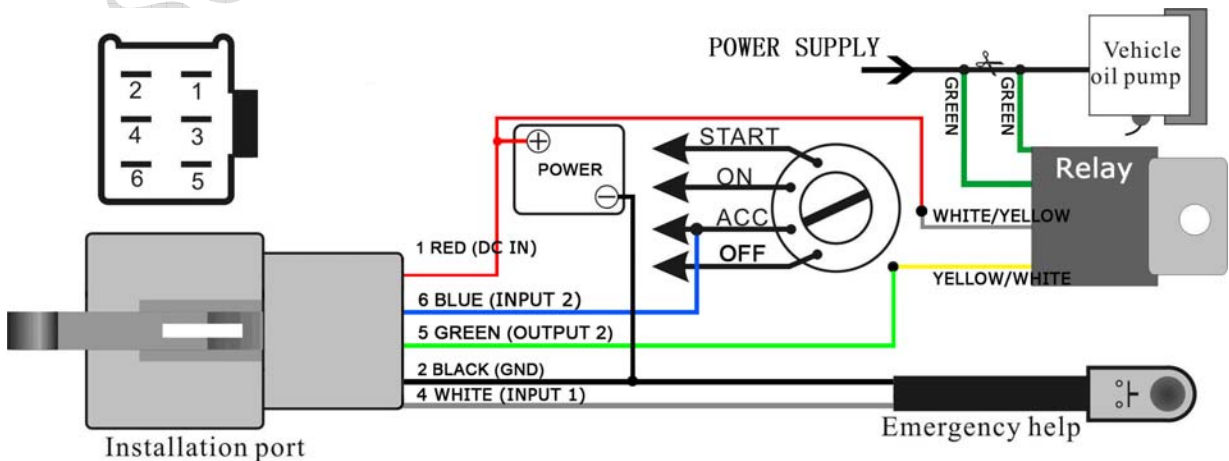

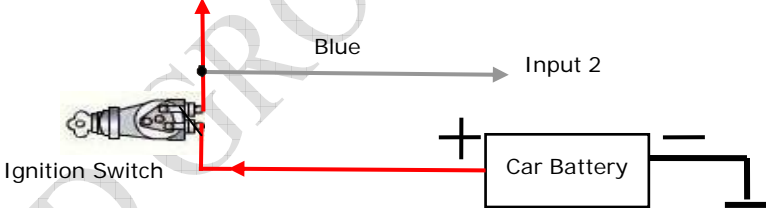
6 pins connector		
Pin	Color	function
1	Red	DC In (power input). Input voltage: 9V~36V. Suggestion: 12V.
2	Black	GND, Car battery cathode connection.
3	Brown (Output 1)	Starter kill relay you can use it to cut the electricity or oil of the car. Low voltage (0V) when effective and open circuit when ineffective. Output open Circuit sink voltage (ineffective): 45V max. Output low voltage sink current (effective): 500mA max. In our 800D web based platform, output 1 (Brown of 6 pins connector) is used to Disable/Enable Oil.
4	White (Input 1)	SOS button, Negative triggering.
5	Green (Output 2)	Starter kill relay you can use it to cut the electricity or oil of the car. Low voltage (0V) when effective and open circuit when ineffective. Output open Circuit sink voltage (ineffective): 45V max. Output low voltage sink current (effective): 500mA max. In our 800D web based platform, output 2 (Green of 6 pins connector) is used to Disable/Enable Power.
6	Blue (Input 2)	ACC signal detecting, Positive triggering. 

According to the relay parameter to make sure to following requirement:
The input voltage of relay must be suited to the car battery

4. Operating Instructions

SMS protocol of AL900, the default password of AL900 is 000000

	SMS Instruction	Format	Remark
1	Request one position	A*****, 000	000: command code *****: password, default 000000
2	Request Google map position	A*****, 100	100: command code *****: password, default 000000
3	Modify user password	A*****, 001 ,#####	001: command code *****: old password , default 000000 #####: new password

4	Set a preset phone number for SOS button and monitoring number etc. When this button is pressed, AL900 will send the SOS and position message to the preset number.	A*****,002,1, Tel Number	002: command code *****: password, default 000000 1 : Set SOS number and monitoring number Tel Number: Preset Tel Number (Tel Number must <20 digits)
	Cancellation number	A*****,002,X	002: command code *****: password, default 000000 X=D: Cancellation all number. X=S: Cancellation SOS number.
	Control the input	A*****,101,ABCDEFGH	101: command code *****: password, default 000000 A=0 Turn off the function of sending sms to preset phone number when ACC on/off A=1 Turn on the function of sending sms to preset phone number when ACC on/off B=0 Turn off the function of sending sms to preset phone number when shock sensor on/off B=1 Turn on the function of sending sms to preset phone number when shock sensor on/off C=0 Turn off the function of sending sms to preset phone number when door open on/off C=1 Turn on the function of sending sms to preset phone number when door open on/off D=0 Turn off the function of sending sms to preset phone number when car main power on/off D=1 Turn on the function of sending sms to preset phone number when car main power on/off E=0 Turn off the function of sending sms to preset phone number when over-speed E=1 Turn on the function of sending sms to preset phone number when over-speed F=0 Turn off the function of sending sms to preset phone number when sos button is pressed F=1 Turn on the function of sending sms to preset phone number when sos button is pressed G= undetermined H= undetermined ABCDEF GH=00000000(Default)

	Example	A000000,101,00000100	Turn on the function of sending sms to preset phone number when sos button is pressed
5	Set the time interval of position refresh SMS send to preset phone number	A***** ,003,XXX	003: command code *****: password, default 000000 XXX: (3 digital) XXX =000, Don't send. (Default) XXX = 001 – 999 time internal (unit: min)
6	Set low power alarm When the AL900 voltage is lower than the preset value, AL900 will send one lower power alarm SMS to the preset phone number. Otherwise, there is not this function in vehicle tracker	A***** ,004,X	004: command code *****: password, default 000000 X : voltage preset value X=0, close (Default) X =1, <3.5V send SMS alarm X =2, <3.6V send SMS alarm X =3, <3.7V send SMS alarm X =4, <3.8V send SMS alarm X =5, <3.9V send SMS alarm
7	Set over speed alarm When the VT800 speed higher than the preset value, VT800 will send one over speed alarm SMS to the preset phone number.	A***** ,005,XX	005: command code *****: password, default 000000 XX : The speed preset value XX = 12 , (Default) 01 ≤ XX ≤ 99 (unit: 10km/h) Example:08=80km/h
8	GPRS Status, To check GPRS Status	A***** ,502	502: command code *****: password, default 000000
9	Get IMEI	A***** ,505	505: command code *****: password, default 000000
10	Set GPRS interval of position refresh	A***** ,506,00030	506: command code *****: password, default 000000 00060: Such as 30 seconds interval is 00030 The default value is:30 seconds. Note: Quiescent state GPRS interval of position refresh is the default value of 60 times. Quiescent state :Speed is less than 3 km/h.
11	Check GPRS interval of position refresh	A***** ,507	507: command code *****: password, default 000000
12	Control the output	A***** ,007,P,F	007: command code *****: password, default 000000 P: The position of the output P =1 output 1 (Brown of 6 pins connector) P =2 output 2 (Green of 6 pins connector)

			<p>F: The control signal</p> <p>F =1 (Active)give the relay the current to drive it (cut the electricity or oil of the car).</p> <p>F =0 (Inactive)cut off the current of the relay. (Recovery the electricity or oil of the car).</p> <p>F=0 (Default)</p>
13	Time zone setting	A***** ,008 ,+8	<p>008: command code</p> <p>*****: password, default 000000</p> <p>+8: Set the local time zone, the default value is +8</p>
14	Inquire the system parameter. Including the software version, password, interval, speed limit, area limit, I/O state, GPS state, SOS number, control number, etc	A***** ,009	<p>009: command code</p> <p>*****: password, default 000000</p>
15	GPRS switch	A***** ,010 ,X	<p>010: command code</p> <p>*****: password, default 000000</p> <p>X: GPRS function</p> <p>=0 GPRS OFF</p> <p>=1 GPRS UDP</p> <p>=2 GPRS TCP (Default)</p>
16	SET APN	A***** ,011 ,APN, username, password	<p>011: command code</p> <p>*****: password, default 000000</p> <p>APN: GPRS use this gateway to connect internet.</p> <p>Username: APN Username</p> <p>Password: APN Password</p> <p>The default APN is CMNET</p>
17	Set the center IP and Port Set the server parameter	A***** ,012 ,IP:Port	<p>012: command code</p> <p>*****: password, default 000000</p> <p>IP: Platform server ip</p> <p>Port: Platform server port</p>
18	LED Light Switch	A***** ,666 , X	<p>666: command code</p> <p>*****: password, default 000000</p> <p>X: LED Light Switch</p> <p>X =0 LED Light OFF.</p> <p>X =1 LED Light ON.(Default)</p>
19	Restart Tracker	A***** ,999	<p>999: command code</p> <p>*****: password, default 000000</p>

5. SMS Tracking by Mobile

5.1. Position Report Function

5.1.1. Get position from vehicle - way 1:

No matter where you are, when you want to know the position of your vehicle

Step1	Send a SMS message or make a telephone call to the AL900.
Step2	vehicle will report its location back to you by SMS, which including the position information

Edit a message as following format, and then send it to AL900:

	Command	Remark
Send Format:	A+Password+,+000	Get position command code is: 000
For Example Send message:	A000000,000	000: command code 000000: password, default 000000
Back information:	Lat:2232.6022N, Lon:11402.2969E	This mean your position is on North Latitude 22 degree 32.2232 cent and East Longitude 114 degree 2.2969 cent

5.1.2. Get position from vehicle - way 2:

Apply for one position service by another way: you need pre-storage the phone number in SIM card:

Step1	Make a cell phone call to AL900
Step2	After listening the ring of AL900, it will hold off after two rings.
Step3	Then, after 10 second, the cell phone will receive the Position SMS. (Its means is AL900 will send Position Data every 5 minute.)

5.2. Tracking Function

Tracking report function can be turned on or off according to the requirements of the user. Tracking function will continually report vehicle position until it get stop command .In this tracking mode, AL900 will send one position message at a preset time interval.

Step1. Edit a message as following format, then send it to AL900

	Command	Remark
Send Format:	A+Password+,+003,+XXX	Note: XXX , if XXX=000 it is STOP tracking Unit: preset minute interval Command code : 003

For example:	A000000,003,003	003: command code 000000: password, default 000000 003: 3 minute interval It means is AL900 will send Position Data every 3 minute.
---------------------	-----------------	--

Step2. AL900 will send back one SMS-----Set Time OK.

This SMS means that AL900 is in tracking mode now and preset time interval is 3 minutes.

Step3. AL900 will send back position SMS at preset time interval.

In this example, the SMS will send back at preset time interval: 3 minute

5.3. Stop tracking function.

This function is used to turn off tracking report function. Edit a message as following format, and then send it to AL900:

	Command	Remark
Command format:	A+passwaord+,+003+,+000	
For example:	A000000,003,000	003: command code 000000: password, default 000: 0 minute interval, mean stop back

6. Track by 800D web based tracking software

The default mode is GPRS when powering on the unit. If you want to use the GPRS functions of the AL900, Send SMS to set APN and IP, Port.

6.1.Set APN

Send the SMS to the tracker as following format

	Command	Remark
Command format:	A+Password+,+011,+APN	
For example:	A000000,011,CMNET	011 : Command code 000000: password, default 000000

		CMNET: APN, is gateway to connect internet, Each country is different, please contact your SIM card provider for APN name.
--	--	--

6.2.Set IP and Port

Send the SMS to the tracker as following format:

	Command	Remark
Command format:	A+Password+,+012,+IP:Port	
For example:	A000000, 012,119.146.223.203:8886	012 : Command code 000000: password, default 000000 119.146.223.203 800D Platform server IP 8886: 800D Platform server software Port

6.3. Add AL900 to 800D web based tracking software

When the AL900 connects to the monitor system, the power LED flash by 1 S. Then you can login in the tracking server to manage your car.

Please go to <http://119.146.223.203>

Enter the user name and password we provided.

After log in, please go to “Vehicle Manager-Vehicle List”

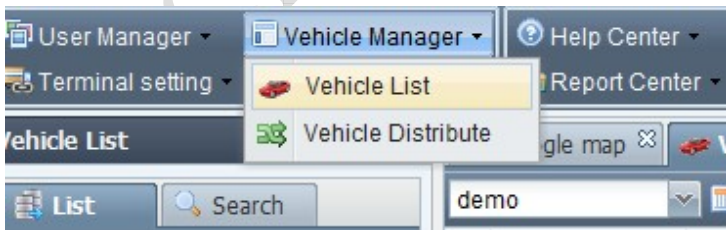

You will see the below window

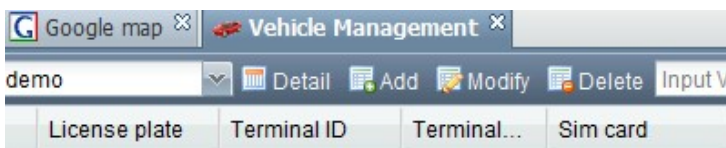

Please click “Add” button, you will see the below window:

The screenshot shows the 'Add vehicle' window with the following fields:

- *License plate: [Empty]
- *Terminal Type: TE1 (highlighted with a red box)
- *Sim card: [Empty]
- *Terminal ID: [Empty]
- Owner Name: [Empty]
- Telephone: [Empty]
- Address: [Empty]
- Remark: [Empty]
- Icon: [Four car icons: blue, black, red, yellow]

 Buttons for 'Submit' and 'Close' are at the bottom.

License Plate: Define by yourself; you can enter A-Z number or Numeric

Very Important Note: Terminal ID and Plate number are unique on the software, you can add once only, you need to delete it from database before adding it again. Only admin account can delete id from database, general user cannot. You do not need to delete and re-add if the device cannot work on software, because it's caused by your wrong sms setting, not the software.

Terminal Type: Choose "TE1"

SIM card: the SIM card phone number you put in AL900.

Terminal ID: On the packing box of AL900, you can find the "ID and IMEI". The ID is Terminal ID.

Very Important Note: Please do not omit the minus if there's a minus before the terminal ID.

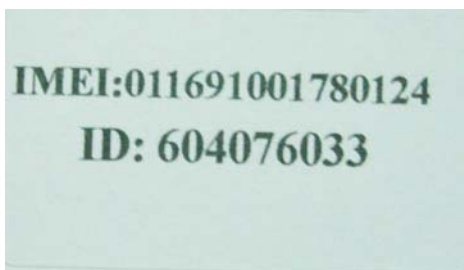

The screenshot shows the 'Add vehicle' window with the following fields filled:

- *License plate: AL900_0925
- *Terminal Type: TE1 (highlighted with a red box)
- *Sim card: 15919871010
- *Terminal ID: 604076033 (highlighted with a red box)
- Owner Name: [Empty]
- Telephone: [Empty]
- Address: [Empty]
- Remark: [Empty]
- Icon: [Four car icons: blue, black, red, yellow]

 Buttons for 'Submit' and 'Close' are at the bottom.

and

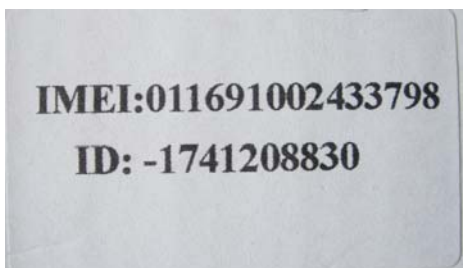

The screenshot shows the 'Add vehicle' window with the following fields filled:

- *License plate: AL900_0930
- *Terminal Type: TE1 (highlighted with a red box)
- *Sim card: 15919871010
- *Terminal ID: -1741208830 (highlighted with a red box)
- Owner Name: [Empty]
- Telephone: [Empty]
- Address: [Empty]
- Remark: [Empty]
- Icon: [Four car icons: blue, black, red, yellow]

 Buttons for 'Submit' and 'Close' are at the bottom.

Click "Submit", and then you add the GPS tracker AL900 successfully on the software 800d.

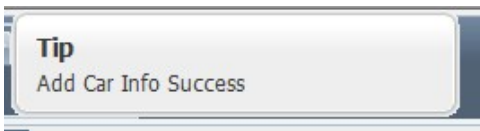

Wait few seconds, and you will see the GPS Tracker online icon on software



Put a check mark on the device, and right click, you will see the menu as below picture. Now you can track online.

