

TEC

TEC Electronic Computing Scale

H-9100N-US/CA

Owner's Manual

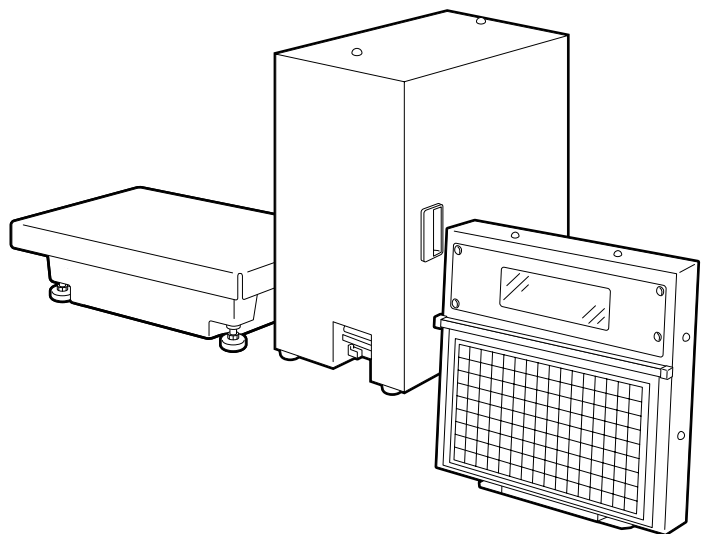

TOSHIBA TEC CORPORATION

Safety Summary

Personal safety in handling or maintaining the equipment is extremely important. Warnings and Cautions necessary for safe handling are included in this manual. All warnings and cautions contained in this manual should be read and understood before handling or maintaining the equipment. Do not attempt to effect repairs or modifications to this equipment. If a fault occurs that cannot be rectified using the procedures described in this manual, turn off the power, unplug the machine, then contact your authorized TOSHIBA TEC representative for assistance.

Meanings of Each Symbol



This symbol indicates warning items (including cautions). Specific warning contents are drawn inside the \triangle symbol. (The symbol on the left indicates a general caution.)



This symbol indicates prohibited actions (prohibited items). Specific prohibited contents are drawn inside or near the \odot symbol. (The symbol on the left indicates "no disassembling".)



This symbol indicates actions which must be performed. Specific instructions are drawn inside or near the \bullet symbol. (The symbol on the left indicates "disconnect the power cord plug from the outlet".)



WARNING

This indicates that there is the risk of **death** or **serious injury** if the machines are improperly handled contrary to this indication.



Any other than the specified AC voltage is prohibited.

■ Do not use voltages other than the voltage (AC) specified on the rating plate, as this may cause **fire** or **electric shock**.



Prohibited

■ Do not plug in or unplug the power cord plug with wet hands as this may cause **electric shock**.



Prohibited

■ If the machines share the same outlet with any other electrical appliances which consume large amounts of power, the voltage will fluctuate widely each time these appliances operate. Be sure to provide an exclusive outlet for the machine as this may cause the machines to **malfunction**.



Prohibited

■ Do not place metal objects or water-filled containers such as flower vases, flower pots or mugs, etc. on top of the machines. If metal objects or spilled liquid enter the machines, this may cause **fire** or **electric shock**.



Prohibited

■ Do not insert or drop metal, flammable or other foreign objects into the machines through the ventilation slits, as this may cause **fire** or **electric shock**.



Prohibited

■ Do not scratch, damage or modify the power cords. Also, do not place heavy objects on, pull on, or excessively bend the cords, as this may cause **fire** or **electrical shock**.



Disconnect the plug.









■ If the machines are dropped or their cabinets damaged, first turn off the power switches and disconnect the power cord plugs from the outlet, and then contact your authorized TOSHIBA TEC representative for assistance. Continued use of the machine in that condition may cause **fire** or **electric shock**.



Disconnect the plug.

■ Continued use of the machines in an abnormal condition such as when the machines are producing smoke or strange smells may cause **fire** or **electric shock**. In these cases, immediately turn off the power switches and disconnect the power cord plugs from the outlet. Then, contact your authorized TOSHIBA TEC representative for assistance.



 <p>Disconnect the plug.</p>  <p>■ If foreign objects (metal fragments, water, liquids) enter the machines, first turn off the power switches and disconnect the power cord plugs from the outlet, and then contact your authorized TOSHIBA TEC representative for assistance. Continued use of the machine in that condition may cause fire or electric shock.</p>	 <p>Disconnect the plug.</p>  <p>■ When unplugging the power cords, be sure to hold and pull on the plug portion. Pulling on the cord portion may cut or expose the internal wires and cause fire or electric shock.</p>
 <p>Connect a grounding wire.</p>  <p>■ Ensure that the equipment is properly grounded. Extension cables should also be grounded. Fire or electric shock could occur on improperly grounded equipment.</p>	 <p>No disassembling.</p>  <p>■ Do not remove covers, repair or modify the machine by yourself. You may be injured by high voltage, very hot parts or sharp edges inside the machine.</p>



CAUTION This indicates that there is the risk of personal **Injury** or **damage** to objects if the machines are improperly handled contrary to this indication.

Precautions

The following precautions will help to ensure that this machine will continue to function correctly.

- Try to avoid locations that have the following adverse conditions:
 - * Temperatures out of the specification
 - * Shared power source
- Do not subject the machine to sudden shocks.
- Do not press the keys too hard. Keys will operate correctly if they are touched lightly.
- Clean the cover and keyboard, etc. by wiping with a dry cloth or a cloth soaked with detergent and wrung out thoroughly. Never use thinner or other volatile solvent for cleaning.
- To ensure that the scale is operating correctly, place a known weight on the platter and check it for correct weight measurement. This should be done every morning before starting normal operations.
- When moving the machine, take hold of the case and lift the machine. Never hold the remote unit.
- Do not place the machines on unstable or slanted surfaces, as they may drop or fall and cause **injury**.
- USE ONLY TOSHIBA TEC SPECIFIED paper.
- DO NOT STORE the paper or ribbons where they might be exposed to direct sunlight, high temperatures, high humidity, dust, or gas.
- Ensure the machine is operated on a level surface.
- Any data stored in the memory of the machine could be lost during a machine fault.
- Try to avoid using this equipment on the same power supply as high voltage equipment or equipment likely to cause mains interference.
- Unplug the machine whenever you are working inside it or cleaning it.
- Keep your work environment static free.
- Do not place heavy objects on top of the machines, as these items may become unbalanced and fall causing **injury**.
- Do not block the ventilation slits of the machines, as this will cause heat to build up inside the machines and may cause **fire**.
- Do not lean against the machine. It may fall on you and could cause **injury**.
- Care must be taken not to injure yourself with the printer paper cutter.
- Unplug the machine when it is not used for a long period of time.

Request Regarding Maintenance

- Utilize our maintenance services.
After purchasing the machine, contact your authorized TOSHIBA TEC representative for assistance once a year to have the inside of the machine cleaned. Otherwise, dust will build up inside the machines and may cause a **fire** or a **malfunction**. Cleaning is particularly effective before humid rainy seasons.
- Our preventive maintenance service performs the periodic checks and other work required to maintain the quality and performance of the machines, preventing accidents beforehand.
For details, please consult your authorized TOSHIBA TEC representative for assistance.
- Using insecticides and other chemicals
Do not expose the machines to insecticides or other volatile solvents. This will cause the cabinet or other parts to deteriorate or cause the paint to peel.

TABLE OF CONTENTS

	Page
1. INTRODUCTION	1- 1
1.1 APPLICABLE MODEL	1- 2
1.2 ACCESSORIES	1- 2
2. SPECIFICATIONS.....	2- 1
2.1 SCALE	2- 1
2.2 OPTION	2- 2
3. APPEARANCE.....	3- 1
4. DISPLAY	4- 1
4.1 US TYPE.....	4- 1
4.2 CA TYPE.....	4- 1
5. KEY LAYOUT.....	5- 1
5.1 PROGRAMMING KEYBOARD.....	5- 1
5.2 OPERATION KEYBOARD AND SPEED KEYBOARD.....	5- 3
6. PROCEDURE BEFORE OPERATION.....	6- 1
7. LEVEL ADJUSTMENT	7- 1
8. REMOVAL AND REPLACEMENT OF RECEIPT/LABEL	8- 1
9. OUTLINE OF OPERATION.....	9- 1
10. PROGRAMMING PROCEDURES.....	10- 1
10.1 UNIT PRICE CHANGE.....	10- 4
10.2 PLU DATA SETTING	10- 5
10.3 INGREDIENT MESSAGE	10- 7
10.4 NUTRITION FACTS	10- 8
10.5 PLU VERIFYING LABEL.....	10-12
10.6 ADDRESS AND COMMERCIAL MESSAGE SETTING	10-13
10.7 COMBINATION MESSAGE	10-14
10.8 SPECIAL INFORMATION	10-16
10.9 GRADE LINE	10-16
10.10 SPEED KEY SETTING	10-17
10.11 PRINT FORMAT	10-18
10.12 DATE/TIME SETTING.....	10-20
10.13 CMT/PL-3.....	10-20
10.14 IN-LINE/LOCAL.....	10-23
10.15 LON SYSTEM.....	10-24
10.16 BAR CODE FORMAT	10-26
10.17 TITLES.....	10-28
10.18 TRANSFERRING LOGO DATA	10-29
10.19 IDIOM SETTING	10-31
10.20 VENDOR SETTING	10-31
10.21 FREE FORMAT SETTING	10-32

11. PROGRAMMED DATA VERIFICATION REPORTS.....	11- 1
12. PASSWORD SECURITY	12- 1
12.1 SETTING PASSWORD AND PROTECT MENU.....	12- 1
12.2 CALLING MENU BY ENTERING PASSWORD	12- 3
13. OPERATING PROCEDURES	13- 1
13.1 WEIGHING OPERATION	13- 2
13.2 FIX PRICE OPERATION (FOR US TYPE ONLY)	13- 3
13.3 BY COUNT OPERATION.....	13- 4
13.4 PRINT COUNT OPERATION.....	13- 6
13.5 ISSUING LABELS WITH NET WEIGHT STATEMENT (FOR US TYPE ONLY)	13- 9
13.6 TARE/SAVE/VOID FUNCTION PROCEDURES	13-11
13.7 CALLING AND PRINTING GRADE LINE	13-12
13.8 CALLING AND PRINTING LOGO	13-13
13.9 SELECTING PRINT ITEM.....	13-14
13.10 DATE CHANGE	13-15
13.11 BATCH PRINT MODE (with 30 Items Run Assignment)	13-16
13.12 VISUAL COMMODITY LIBRARY	13-19
13.13 FLOATING VENDOR.....	13-20
14. TOTAL OPERATION.....	14- 1
14.1 HOURLY TOTAL REORT	14- 2
14.2 GRAND TOTAL REPORT.....	14- 2
14.3 PLU TOTAL REPORT.....	14- 2
14.4 VENDOR TOTAL REPORT	14- 3
15. ERROR MESSAGE TABLE	15- 1
16. CLEANING THE PRINT HEAD	16- 1
17. TROUBLESHOOTING	17- 1

WARNING!

1. *The display unit installation should be authorized installing dealer. Please contact your nearest TOSHIBA TEC representative.*
2. *The display unit installation by anyone except an authorized installing dealer will release the manufacturer from all liability for damage or injury to users.*

CAUTION:

1. *This manual may not be copied in whole or in part without prior written permission of TOSHIBA TEC.*
2. *The contents of this manual may be changed without notification.*
3. *Please refer to your local Authorized Service representative with regard to any queries you may have in this manual.*

1. INTRODUCTION

Thank you for purchasing the TEC H-9100N series electronic computing scale.

H-9100N series is developed to be used in the store back room.

As you will discover, it has many features and functions designed for user friendliness as well as complete customer satisfaction.

Stainless steel is used for the covers. Since the printer unit can hold a maximum of 230 mm label roll, this model is suitable for printing a great deal of labels.

The 256 x 64 dot fluorescent display provides customers with ample information, the 216 speed keys realize a higher degree of operability, and the 3 inch/sec. Print speed ensures fast and clear printing.

Password security prevents unauthorized access to the PROG., M. DOWN, REWRAP, REPORT and RESET modes.

The latest high speed in-line system, Local Operating Network (LON), allows easy system configuration and greater throughput.

Various options, including a TMCC Interface, a LAN Interface, etc., are selectable in accordance with your needs.

We believe that your needs will be fully satisfied, and you will have total reliability in price calculation. Should you have any questions concerning the scale, please refer to this manual. Be sure to keep this manual for future reference.

This equipment has been tested and found to comply with the limits for a Class A digital device, pursuant to Part 15 of the FCC Rules. These limits are designed to provide reasonable protection against harmful interference when the equipment is operated in a commercial environment. This equipment generates, uses, and can radiate radio frequency energy and, if not installed and used in accordance with the instruction manual, may cause harmful interference to radio communications. Operations of this equipment in a residential area is likely to cause harmful interference in which case the user will be required to correct the interference at his own expense.

(for USA only)

Changes or modifications not expressly approved by manufacturer for compliance could void the user's authority to operate the equipment.

"This Class A digital apparatus meets all requirements of the Canadian Interference-Causing Equipment Regulations."

"Cet appareil numérique de la classe A respecte toutes les exigences du Règlement sur le matériel brouilleur du Canada."

(for CANADA only)

Some procedures described in this manual may be illegal in various state jurisdictions. When there are optional settings to enable various functions or to disable functions. Please ensure that the optional settings for scale operation meet the local requirements of weights and measures. If you are uncertain of specific items, contact the state or county office of weights and measures for clarification.

1.1 APPLICABLE MODEL

- H-9100-50L-N-FFB-US
- H-9100-25-N-FFB-CA

The description of the model number is as follows.

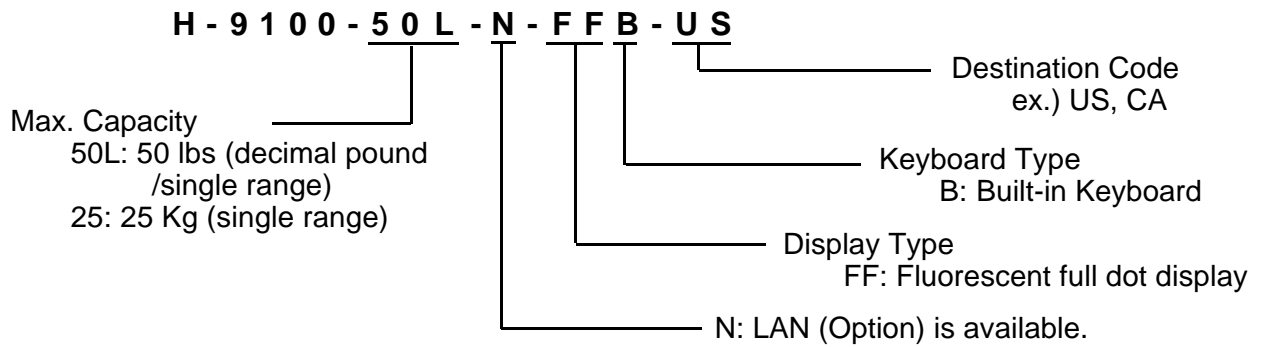

1.2 ACCESSORIES

Owner's Manual
(EO1-32003)

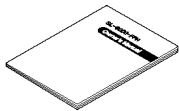

Receipt Cutter



Quality control
report (US type only)

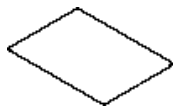

Power Cord



Print Head Cleaner
(24089500013)

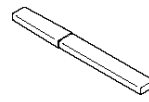

Sealing Wire



Sealing Lead



Cable Band



NOTE: Check that there are no missing or incorrect parts in the accessories.

CAUTION:

Be sure to use the provided power cord.

2. SPECIFICATION

2.1 SCALE

Item	US	CA
Maximum Capacity	50 lb	25 Kg
Minimum Scale Division	0.01 lb	0.005 Kg (0.01 lb)
Display Range	0 to 50.05 lb	0 to 25.025 Kg (0 to 50.05 lb)
Maximum Tare	4.00 lb	2.000 Kg (4.41 lb)
Unit Price Presetable	\$ 0.01 to 99.99	\$ 0.01 to 99.99
Minimum Price Display	\$ 0.01	\$ 0.01
Power Requirement	AC 120 V \pm 10%, 60 Hz	
Power Consumption	US/CA: 94 W, 1.4 A (Standby: 24 W, 0.3 A)	
Temperature Limits	32°F to 104°F (0 to 40)	
Relative Humidity	35 % to 85 % (No condensation)	
Message Display	256 x 64 dots Fluorescent display	
Weight	5 digits	
Unit Price	4 digits	
Total Price	5 digits	
Display Mode	Single side	
Capacity of PLU Memory	3600 PLUs max. (standard)	
Print Head	Thermal Print Head (3 inch wide)	
Media Issue Method	On-demand/Batch	
Dot Density	640 dots (8 dots/mm x 80mm), W0.125 x H0.125mm square dot	
Print Speed	4 inch/sec. (101.6 mm/sec.) (3 inch/sec. can be selected for lower sensitive labels.)	
Available Media Width	2.24 inch (57 mm), 3.14 inch (80 mm)	
Recommended Media Thermal Label	VHTS (OSP), NP-AH1X, NP-AH2H (TAC)/Outer diameter: Ø 230 mm (Max.)	
Variable Length Label	VHTS (OSP), NP-AH1X, NP-AH2H (TAC)/Outer diameter: Ø 230 mm (Max.)	
Thermal Receipt Interface	120 FC (RICOH)/Outer diameter: Ø 90 mm (Max.) CMT/PL-3 interface (Program Loader) LON interface (RS-485) TMCC interface (Option) PC-AT KEY interface (option) Drawer Interface LAN interface (10 Base T, option)	
Dimensions (approx.) Printer Unit	9.2 inch (width) x 14.5 inch (depth) x 17.3 inch (height) 234 mm (width) x 369 mm (depth) x 439 mm (height)	
Display Unit	15.4 inch (width) x 1.7 inch (depth) x 13.3 inch (height) 390 mm (width) x 43.5 mm (depth) x 339 mm (height)	
Scale unit	15.7 inch (width) x 10.2 inch (depth) x 4.3 inch (height) 400 mm (width) x 260 mm (depth) x 110 mm (height)	
Weight	55.1 lb (25 Kg)	

2.2 OPTION

Option Name	Model No. or Part No.	Description	Source	
LON	LON Connector TM8P-88P	Part No. EAJ-0028001	A modular connector used to connect scales to each other in a LON configuration.	See Note 2
	LON Terminal Resistor 285D-8P	Part No. EAJ-0029001	A modular resistor attached to the scales connected at both ends of the LON configuration.	See Note 2
	LON Cable S-STLAN-2P (200 m/roll)	Part No. 10319100003	An 8-pin telephone cable used with the LON connectors attached to both ends of the cable. This cable connects scales to each other in a LON configuration.	See Note 2
	LON Ferrite Core ESD-SR-15	Part No. DDG-0106001	A ferrite core for the LON interface	See Note 2
I/O PC Board	OP-9000-IOB	An I/O board equipped with the TMCC interface and PC-AT keyboard interface ports. It is used to construct a TMCC system and program PLU data, etc..	See Note 1	
TMCC Cable kit	OP-9000-IOCN-TMCC	A cable kit for the TMCC interface.	See Note 1	
Memory Module	OP-9000-SRAM-512KB	DIP type S-RAM to be installed on the MEMO PC board for memory expansion. When expanding the memory, install the two modules as one set.	See Note 1 and 3	
10 Base T (LAN) Interface Board (H-9100N only)	OP-9000N-LAN	This board enables the H-9100N to be used in a LAN network.	See Note 1	

NOTES:

1. Contact TOSHIBA TEC H.Q. or your nearest TOSHIBA TEC representative.
2. Order from TOSHIBA TEC Parts Center or purchase locally.
3. When purchasing memory modules locally, select one having the following specifications.
 Maker: HITACHI Static RAM (OP-9000-SRAM-512KB)
 Type: HM628512ALP-770ns, 600mil 32-pin Plastic DIP (DP-32) (OP-9000-SRAM-512KB)

3. APPEARANCE

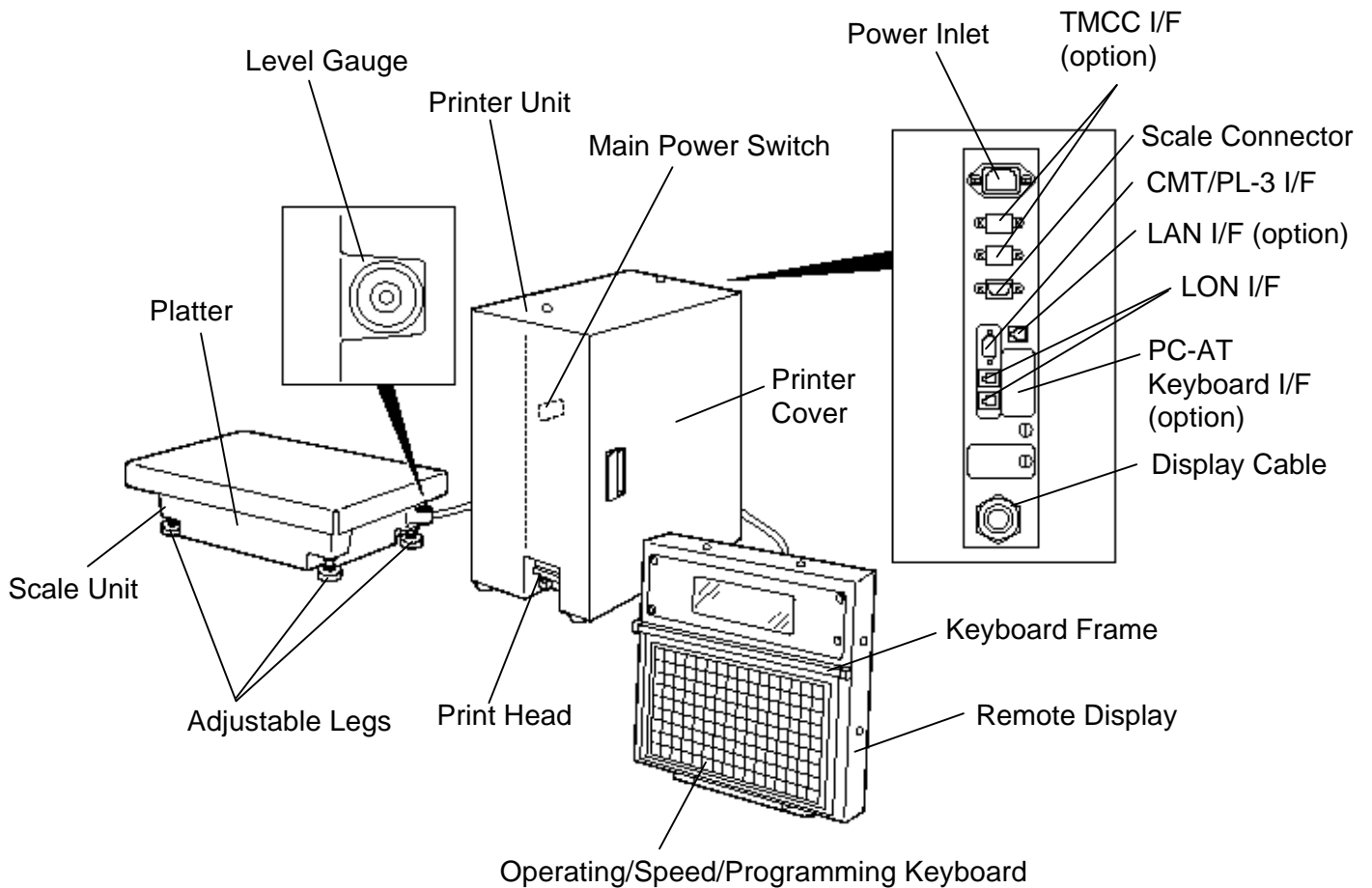

- NOTES:**
1. The main power switch is provided inside of the printer unit. When turning the power switch on/off, open the printer cover.
 2. To set the speed/operation key sheet, open the keyboard frame and insert the two tabs of the key sheet into the two slots of the keyboard frame bottom.

4. DISPLAY

4.1 US TYPE

■ Front Display Panel

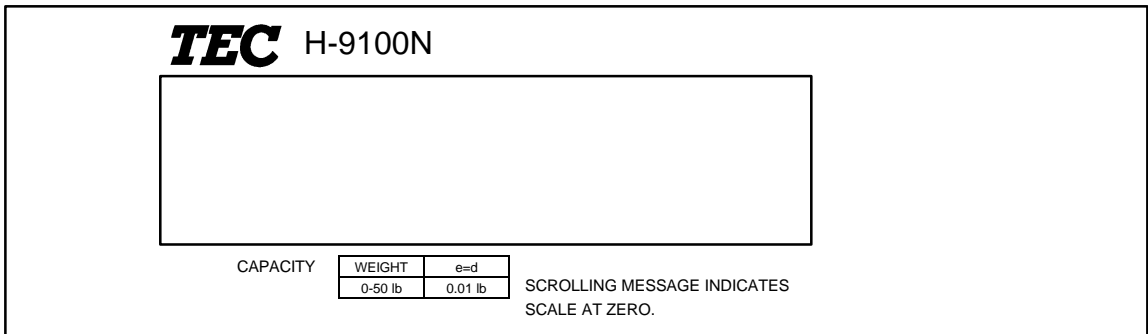

4.2 CA TYPE

■ Front Display Panel

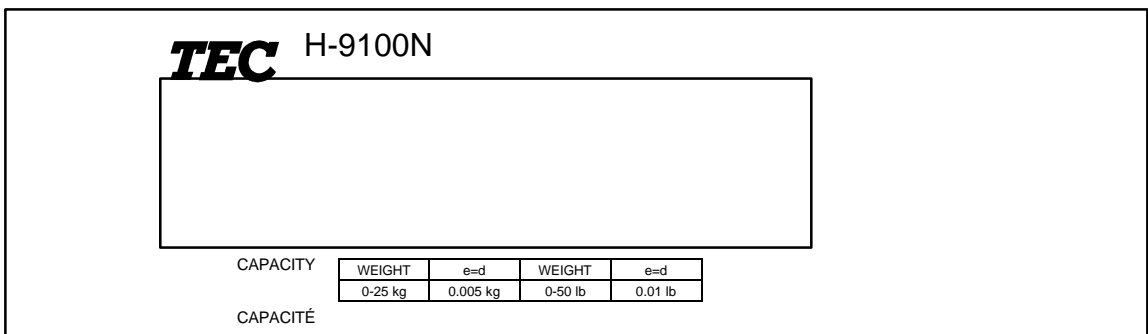

5. KEY LAYOUT



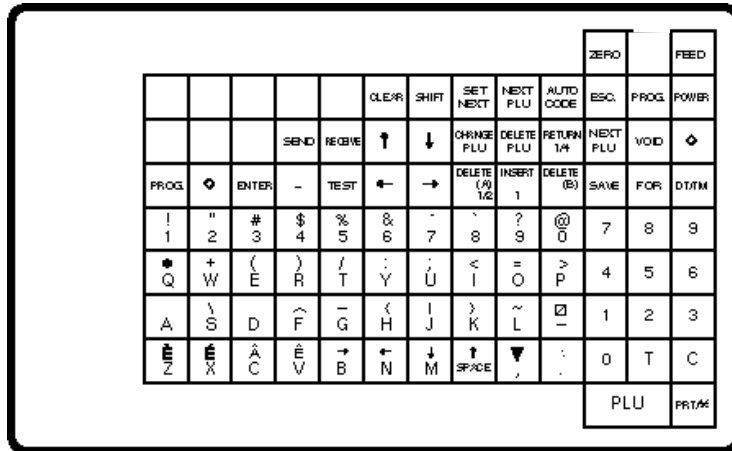







5.1 PROGRAMMING KEYBOARD

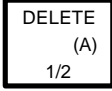
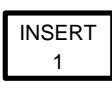

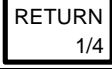
NOTE: Blank keys have no function.

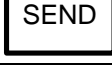
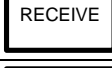
Programming Keyboard Function

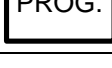
Name of Key	Function
CLEAR	1. Clears numeric data just entered. 2. Releases the scale from the error mode.
SHIFT	Selects the upper case or lower case.
SET NEXT	Calls the PLU # which follows the currently called PLU #. Sets the media transparency on the sensor.
NEXT PLU	Calls the PLU # registered right after the currently called PLU #.
AUTO CODE	Sets "AUTO CODE".
CHANGE PLU	Changes the PLU # currently called.
DELETE PLU	Deletes PLU.
TEST	Prints the data in the currently called PLU.
ENTER	Inputs data to the H-9100N system during programming.
VOID	Displays the preceding PLU data. (only when changing the unit price)
PRT/*	Inputs data to the H-9100N system during programming. (only when changing the unit price)
ESC.	Returns to the main menu.

Name of Key	Function
	<ol style="list-style-type: none"> 1. Displays the preceding PLU data. 2. Used for setting an auto code. 3. Calls the preceding label format # when setting the print position.
	<p>Moves the cursor to left.</p>
	<p>Moves the cursor to right.</p>
	<ol style="list-style-type: none"> 1. Deletes the character selected by the cursor when setting the commodity name or message. 2. Sets a unit price per 1/2 lb.
	<ol style="list-style-type: none"> 1. Inserts a space at the cursor position when setting the commodity name or message. 2. Sets a unit price per lb/100g/Kg.
	<p>Deletes all characters on the current setting line when setting the commodity name or message.</p>
	<ol style="list-style-type: none"> 1. Displays the next line when setting the ingredient or message. 2. Sets a unit price per 1/4 lb.
	<p>Inserts a blank space in descriptors.</p>
	<p>Stores "ingredient data" in the temporary memory.</p>
	<p>Calls "ingredient data" from the temporary memory.</p>
	<p>Sets the preceding item when setting PLU and nutrition information.</p>
	<p>Sets the following item when setting PLU and nutrition information.</p>
	<p>Returns to the programming menu.</p>
	<ol style="list-style-type: none"> 1. Changes the programming menu page. 2. Selects capitals or small letters. 3. Sorts the file when setting PLU data, ingredient data and nutrition data. 4. Sets a block PLU # using the confirmation label procedure. 5. Selects the scrolling message or fixed message. 6. Calls the second half of the speed key and sets a department #. 7. Selects the adjusting item of print format in rotation. 8. Toggles between In-line and Local or in-line and off-line of LON system.
<p>Other Keys</p>	<p>The other keys are used to set the character.</p>

5.2 OPERATION KEYBOARD AND SPEED KEYBOARD

	US type	CA type
①	1/2	100g
②	1/4	Lb/kg

1	2	3	4	5	6	7	8	9	10	11	12	AUTO/Manual	ZERO	TEST	FEED
13	14	15	16	17	18	19	20	21	22	23	24	①	ESC.	PROG	POWER
25	26	27	28	29	30	31	32	33	34	35	36	②	NEXT PLU	VOID	◆
37	38	39	40	41	42	43	44	45	46	47	48	RESET COUNT	SAVE	FOR	DTTM
49	50	51	52	53	54	55	56	57	58	59	60	GRADE LINE	7	8	9
61	62	63	64	65	66	67	68	69	70	71	72	LOGO	4	5	6
73	74	75	76	77	78	79	80	81	82	83	84	GROUP	1	2	3
85	86	87	88	89	90	91	92	93	94	95	96	ST	0	T	C
97	98	99	100	101	102	103	104	105	106	107	108	%	PLU	PRT/◆	











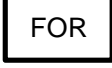

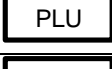
NOTES:

1. Pressing the key enables another 108 PLUs assignment.
2. The “%” key is effective when initial set #28-4 = 1.
The “Auto/Manual” key is effective when initial set #12-8 = 1.



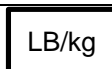
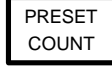
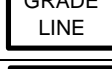
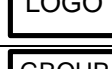

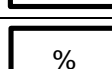

Operation Keyboard Function

Name of Key	Function
<input type="text" value="0"/> to <input type="text" value="9"/>	Enters numeric data such as PLU #, unit price and tare.
<input type="text" value="C"/>	1. Clears numeric entries. 2. Releases the scale from error mode. 3. Releases the scale from SAVE mode.
<input type="text" value="T"/>	Subtracts tare.
<input type="text" value="PLU"/>	Calls a PLU or clears the displayed PLU.
<input type="text" value="PRT/*"/>	Prints a customer label.

Operation Keyboard Function

Name of Key	Function
	Saves tare and unit price after taking off the commodity from the platter.
	Sets the quantity of a commodity in "BY COUNT" mode.
	Displays the date.
	Selects the item for change Print/OFF.
	Corrects data just after the registration.
	1. Enables calling the other 108 speed keys. 2. Selects the function for change Print/OFF.
	Returns to the main menu.
	Accesses print item, auto message timer, print format and issue mode selection mode.
	Turns the display on/off when the scale power is on.
	Changes between 1/2 lb and 1/4 lb (US type only).
	Changes the unit of measure to 100 g (CA/QR type only).
	Changes the unit of measure between lb and kg (CA/QR type only).
	Sets the number of labels to print.
	Prints a grade line.
	Calls the logo.
	No function.
	No function.
	This key is used for item or subtotal discount by entering a percentage. (Optional key by initial setting)

Operation Keyboard Function

Name of Key	Function
	Feeds the label.
	Issues a test label.
	Adjusts the zero point.
	Changes the label issue mode between automatic issue and manual issue. (Optional key by initial setting)
 to 	Calls the assigned PLU.

6. PROCEDURE BEFORE OPERATION

1. Unpack the accessories and H-9100N units from the carton.
2. Refer to Safety Precautions in this manual and set up the H-9100N units in proper location.
3. Connect the scale unit to the printer unit.
4. Connect the power cord to the printer unit.
5. Connect the LON cable to the printer unit, if necessary.
6. Load the label or receipt roll.
7. Insert the power cord plug into an AC outlet.
8. Level the printer unit. (Refer to Section 7.)
9. Connect a PC-AT keyboard, if necessary.
10. Turn the power on and press the power key on the keyboard.
11. Set the following programming menus.

Menu Page	ITEM No.	Programming Name
2	0	PRINT FORMAT
2	1	DATE/TIME SETTING
1	1	PLU DATA SETTING

If necessary, set the following program menu:

Menu Page	ITEM No.	Programming Name
1	2	INGREDIENT MESSAGE
1	3	NUTRITION SETTING
1	5	ADDRESS AND COMMERCIAL MESSAGE SETTING
1	7	SPECIAL INFORMATION
1	8	GRADE LINE
1	9	SPEED KEY SET

12. Call a PLU which contains the unit price used in weighing mode, then place a weight on the platter and check a correct price is displayed.
13. The scale is ready to issue labels.

NOTE: For details of the programming menus, refer to Section 10.

CAUTION:

Be sure to use the provided power cord.

7. LEVEL ADJUSTMENT

1. Level Gauge

Set the scale on a stable and level surface. Level the scale by turning the adjustable legs so that the air bubble is inside the center circle.

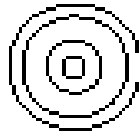

Correct

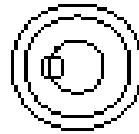

Incorrect

2. Adjustment Procedure

(1) When the air bubble moves toward the left side, turn the right adjustable legs clockwise.

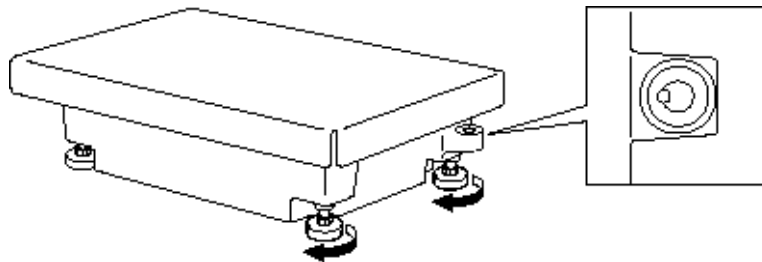

(2) When the air bubble moves toward rear, turn the front adjustable legs clockwise.

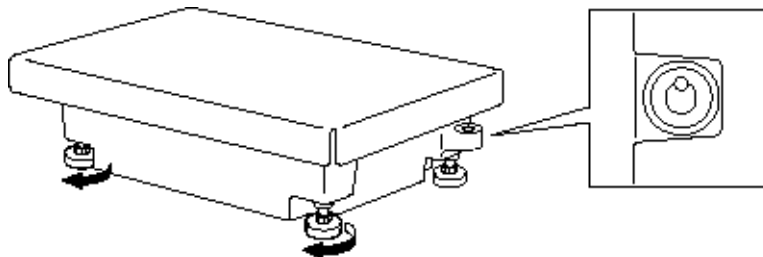

8. REMOVAL AND REPLACEMENT OF RECEIPT/LABEL

1. Open the printer cover and turn the head-up lever to the anti-clockwise.
2. Pull out the roll stopper and backing paper stopper, then remove the receipt/label roll together with the backing paper roll. You can loosen the backing paper roll by turning the take-up shaft anti-clockwise.

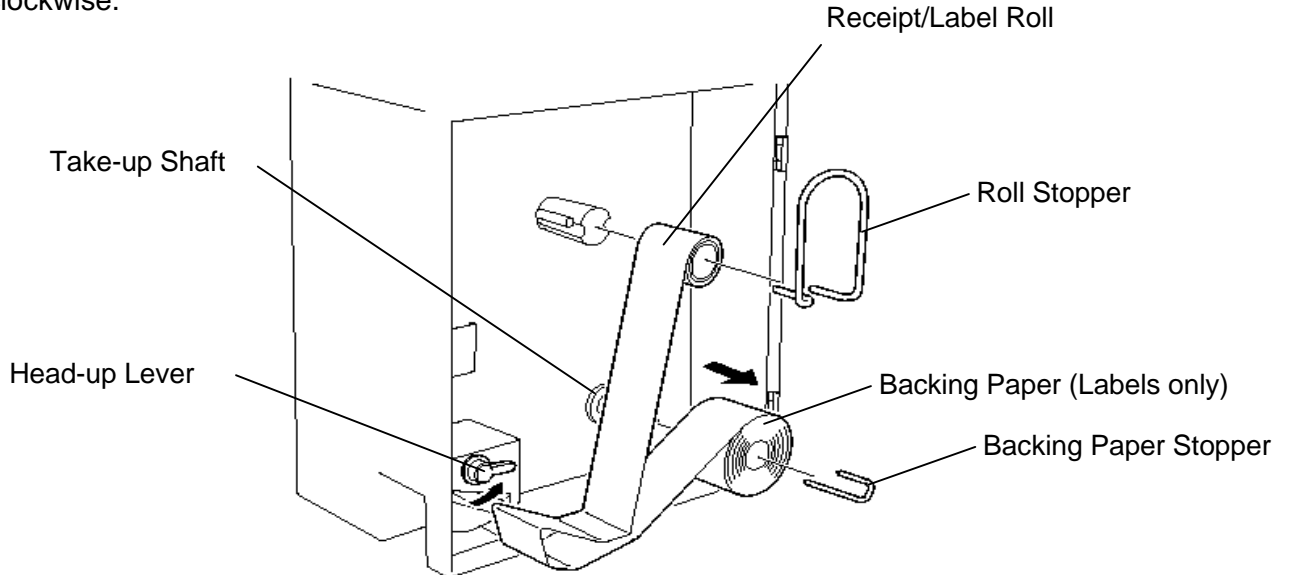

3. Put a new receipt/label roll over the media shaft and fix it with the roll stopper.

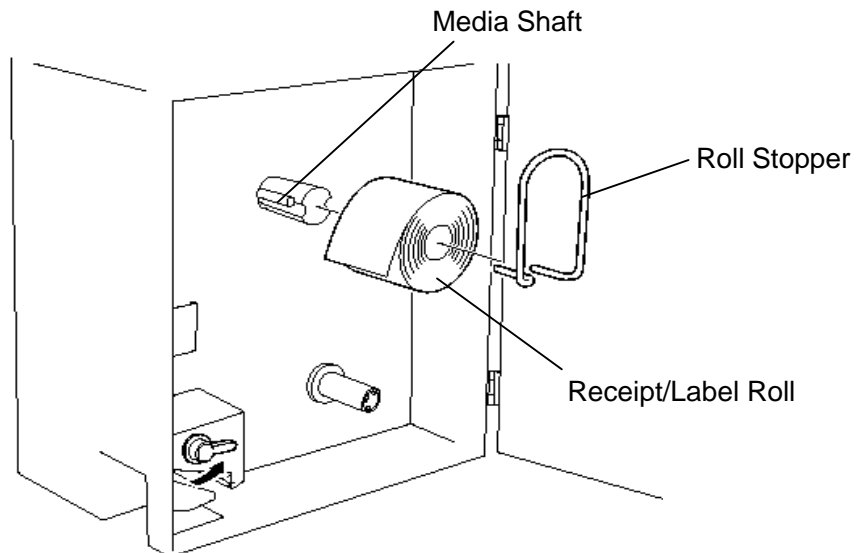

4. Insert the tip of the receipt/label under the print head.
5. Align the right media guide with the right edge of the receipt/label.
NOTE: Always keep the left media guide located at the left edge of the media outlet.

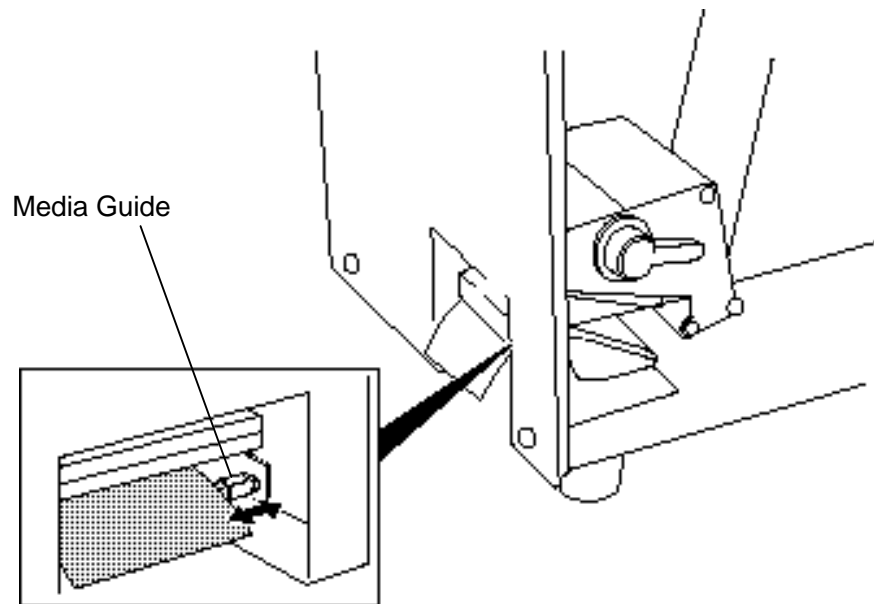

6. Thread the receipt/label as shown below.
NOTE: Labels and receipts should be left-aligned as viewed from the front of the machine, and always threaded in parallel with the media shaft and the print head. Failure to do this may cause a paper jam or a skew feed.
7. Turn the head-up lever to the arrow indicating direction to set the print head in position.

(Label threading method)

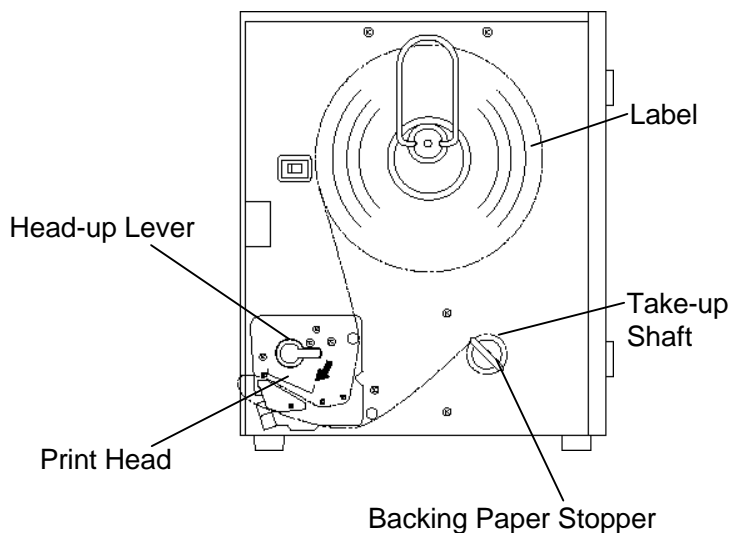

(Receipt threading method)

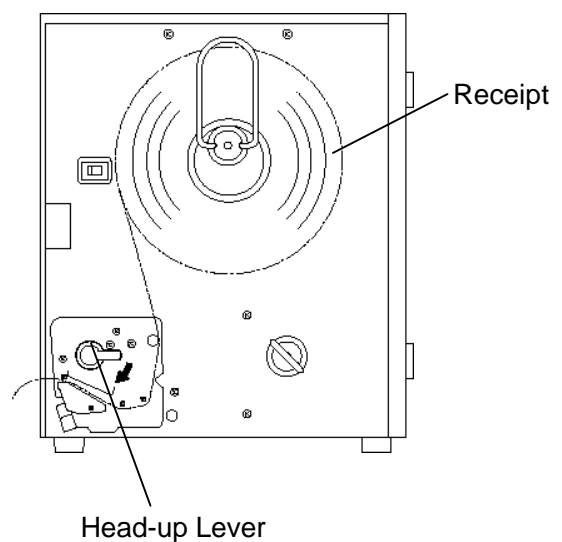

8. Close the printer cover.
9. Finally press the Feed key to confirm that the labels/receipts are loaded correctly.

9. OUTLINE OF OPERATION

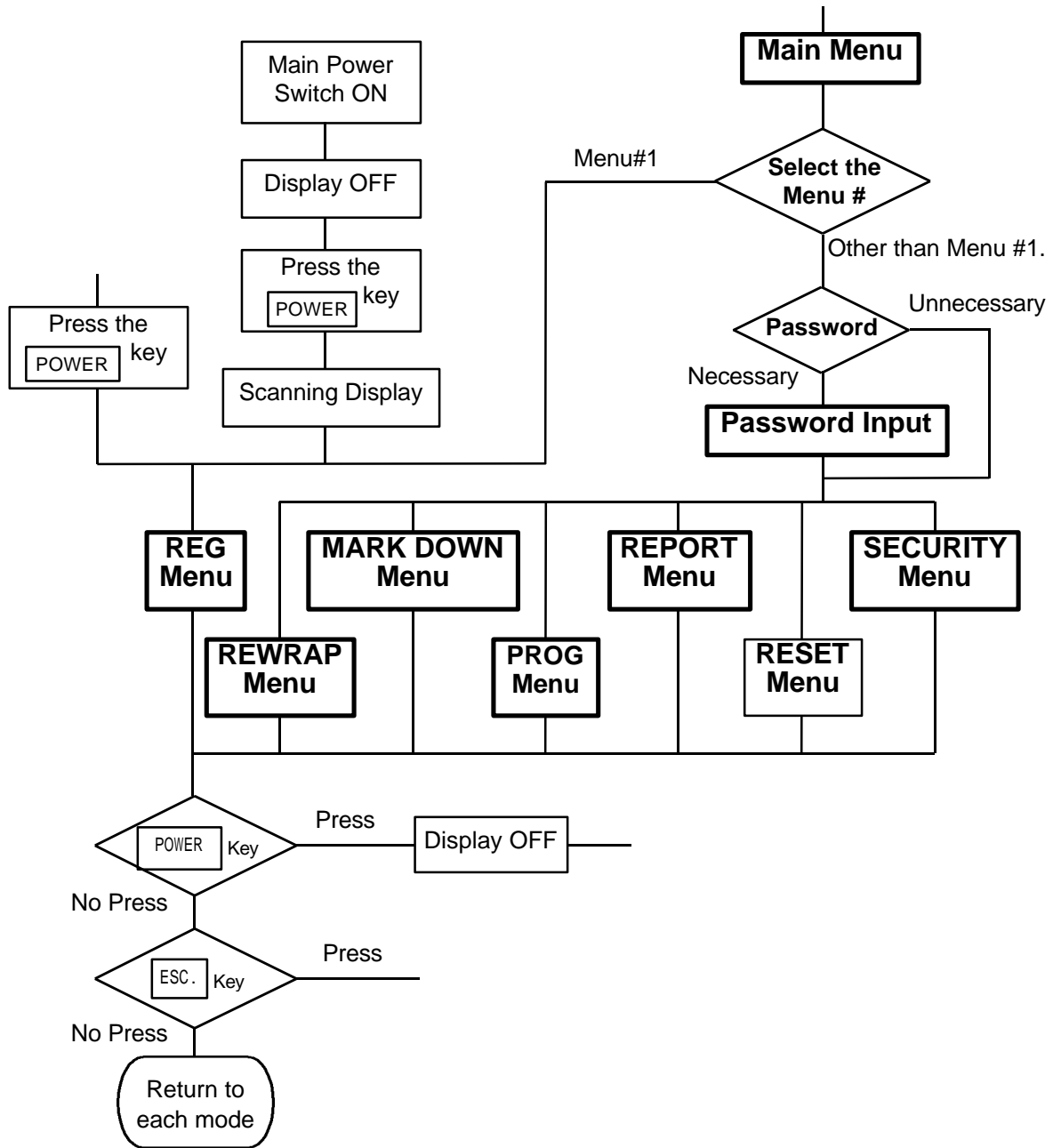

NOTES:

1. You can register a password to avoid unauthorized access to each menu except for REG. menu.
2. To avoid unneeded use of the display, press the **POWER** key to turn the display off while being unused. Pressing the **POWER** key again allows you to enter REG mode without scanning.
3. Refer to respective sections for explanation of each menu enclosed by a thick rectangle.

10. PROGRAMMING PROCEDURES

How to access to Programming Menu

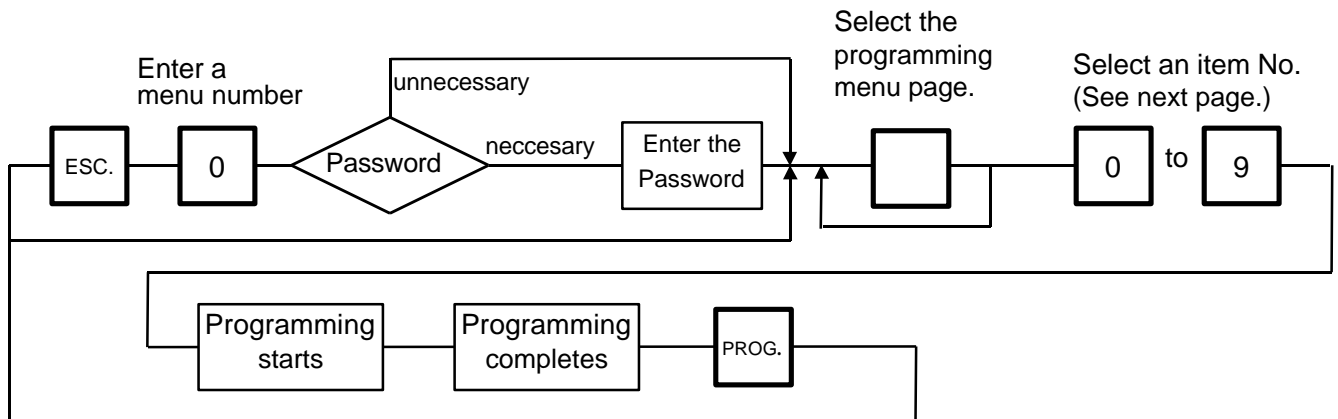

NOTES:

1. When the selected menu ([0]) is protected from an access, refer to Section 12.2 and enter the password.
2. In Section 10.1, 10.2 and 10.3, items which have been sold on that day cannot be called before resetting (refer to Section 14) unless Initial Setting #1-4 is set to 1.

<Menu> PROG.1	
0. PLU DATA EDIT	5. MESSAGE
1. PLU DATA	6. MSG. COMBINATION
2. INGREDIENT	7. SPECIAL INFO
3. NUTRITION	8. GRADE LINE
4. CONFIRMATION LABEL	9. SPEED KEY SET



<Menu> PROG.2	
0. PRT LOCATION	5. INITIAL SET
1. DATE TIME	6. BAR CODE FORMAT
2. CMT	7. TITLE
3. ON-LINE/LOCAL	8. LOGO
4. LON SYSTEM	9. IDIOM



<Menu> PROG.3	
0. VENDOR NAME	
1. FREE FORMAT	
2. LAN SYSTEM	

Title and Contents of Programming Menu

Table 1.

NO.	TITLE	MENU PAGE	ITEM NO.	CONTENTS	Page
1	PLU DATA EDIT	1	0	CHANGE UNIT PRICE	10-4
2	PLU DATA	1	1	PROGRAM/CHANGE/DELETE PLU	10-5
3	INGREDIENT	1	2	PROGRAM/CHANGE INGREDIENT	10-7
4	NUTRITION	1	3	PROGRAM/CHANGE NUTRITION FACTS TABLE	10-8
5	CONFIRMATION LABEL	1	4	VERIFY THE PROGRAMMING DATA OF PLU	10-12
6	MESSAGE	1	5	PROGRAM MESSAGE/ADDRESS	10-13
7	MSG. COMBINATION	1	6	PROGRAM MESSAGE ON DISPLAY AND TIME	10-14
8	SPECIAL INFO.	1	7	PROGRAM SPECIAL INFORMATION	10-16
9	GRADE LINE	1	8	PROGRAM GRADE LINE	10-16
10	SPEED KEY SET	1	9	ASSIGN COMMON PLU TO SPECIFIC SPEED KEY	10-17
11	PRT LOCATION	2	0	SELECT LABEL FORMAT AND ADJUST	10-18
12	DATE TIME	2	1	PROGRAM DATE/TIME/MACHINE #/STORE CODE	10-20
13	CMT/PL-3	2	2	BACK-UP/LOAD DATA OF PLU/ING/NUTRI./SPEED KEY	10-20
14	ON-LINE/LOCAL	2	3	SET PARAMETERS FOR TMCC	10-23
15	LON SYSTEM	2	4	SET PARAMETERS FOR LON	10-24
16	INITIAL SET	2	5	SET INITIAL PARAMETERS	—
17	BAR CODE FORMAT	2	6	PROGRAM BARCODE FORMAT	10-26
18	TITLE	2	7	PROGRAM/CHANGE TITLE ON DISPLAY/PRINT	10-28
19	LOGO	2	8	SEND/RECEIVE LOGO DATA	10-29
20	IDIOM	2	9	PROGRAM IDIOM	10-31
21	VENDOR NAME	3	0	VENDOR NAME	10-31
22	FREE FORMAT	3	1	PROGRAM FREE FORMAT	10-32
23	LAN SYSTEM	3	2	PROGRAMS PARAMETERS FOR LAN	—

NOTE: Menu No. 16 and 23 are program for use of dealers. Contact a TOSHIBA TEC representative if you desire to use them. When you enter one of these menus by mistake, press ESC. key to return to Main Menu.

How to enter characters

Use the following procedure to enter a commodity name, address and ingredient message.

Example) 1st line: TEC STORE
 2nd line: (TEL) 0123-45-6789

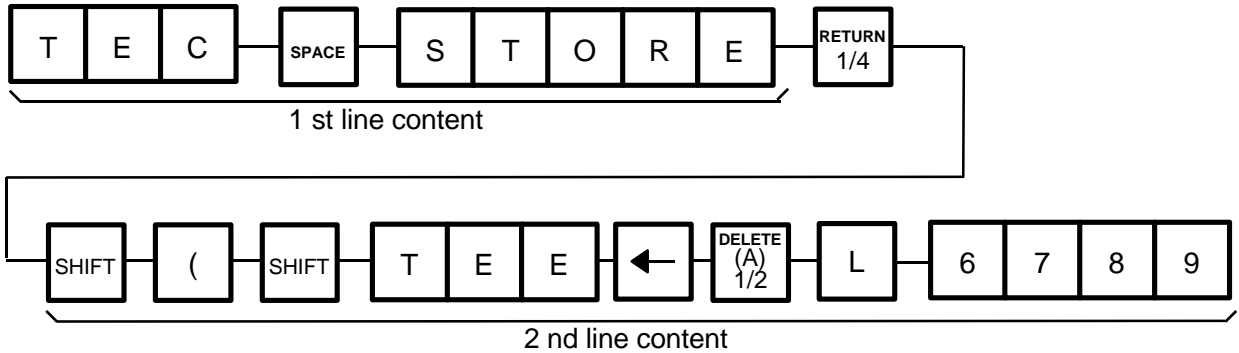

NOTES:

1. and keys are the cursor keys.
2. To insert a space, move the cursor to the next character to the space to be inserted, and press key.
3. To delete a line, press key.
4. To move the cursor to the preceding line when entering a commodity name, press key, or key.
5. Pressing the key toggles between the capital and small letter.
6. When entering a commodity name, press the key instead of the key to return.
7. Pressing the key toggles the type font between normal and boldface.
8. To call a preset ingredient message idiom, follow the procedure below:

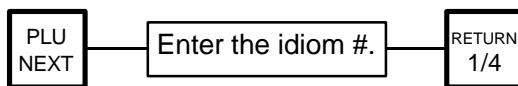

9. To skip a line when entering an ingredient message, follow the procedure below:

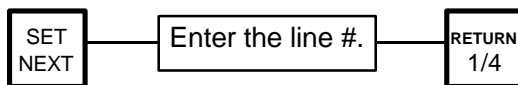

10.1 UNIT PRICE CHANGE

Menu Page: 1
 Item No.: 0

In this procedure, use the operation keys (except when calling a PLU by using a speed key).
 The unit price stored in a PLU can be changed with this menu.

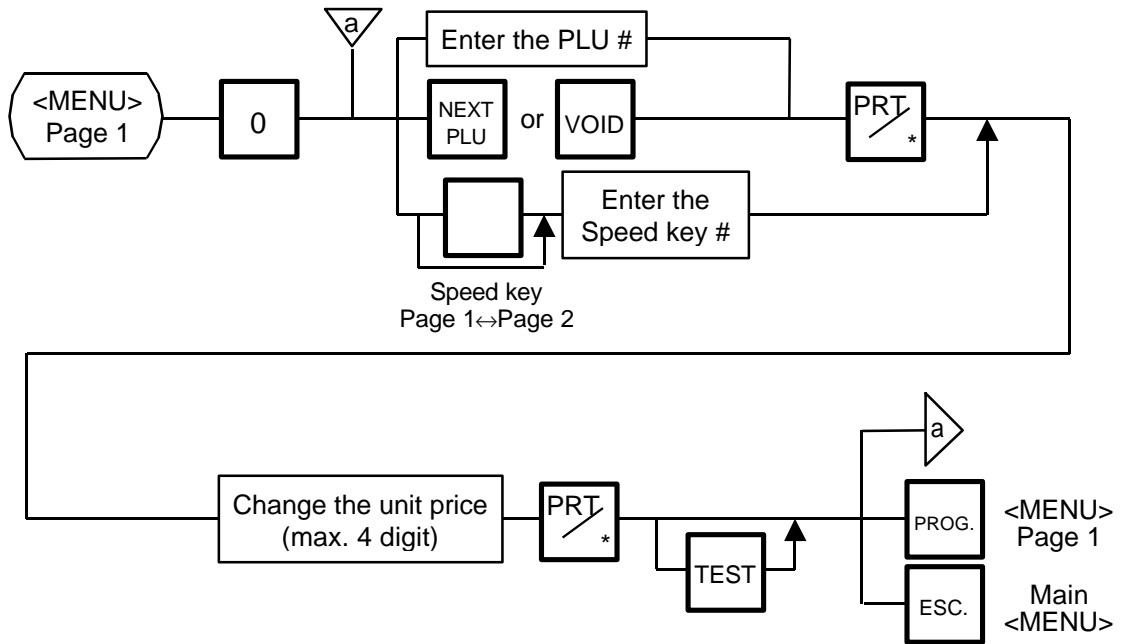

NOTES:

1. Calling a PLU # that has not been stored in the PLU file results in an error.
2. Under this Menu (Menu No. 0), "open-price" PLU's price cannot be changed.

10.2 PLU DATA SETTING

Menu Page: 1

Item No.: 1

Setting or changing the contents of PLU (PLU#, UPC#, Commodity Name, etc).

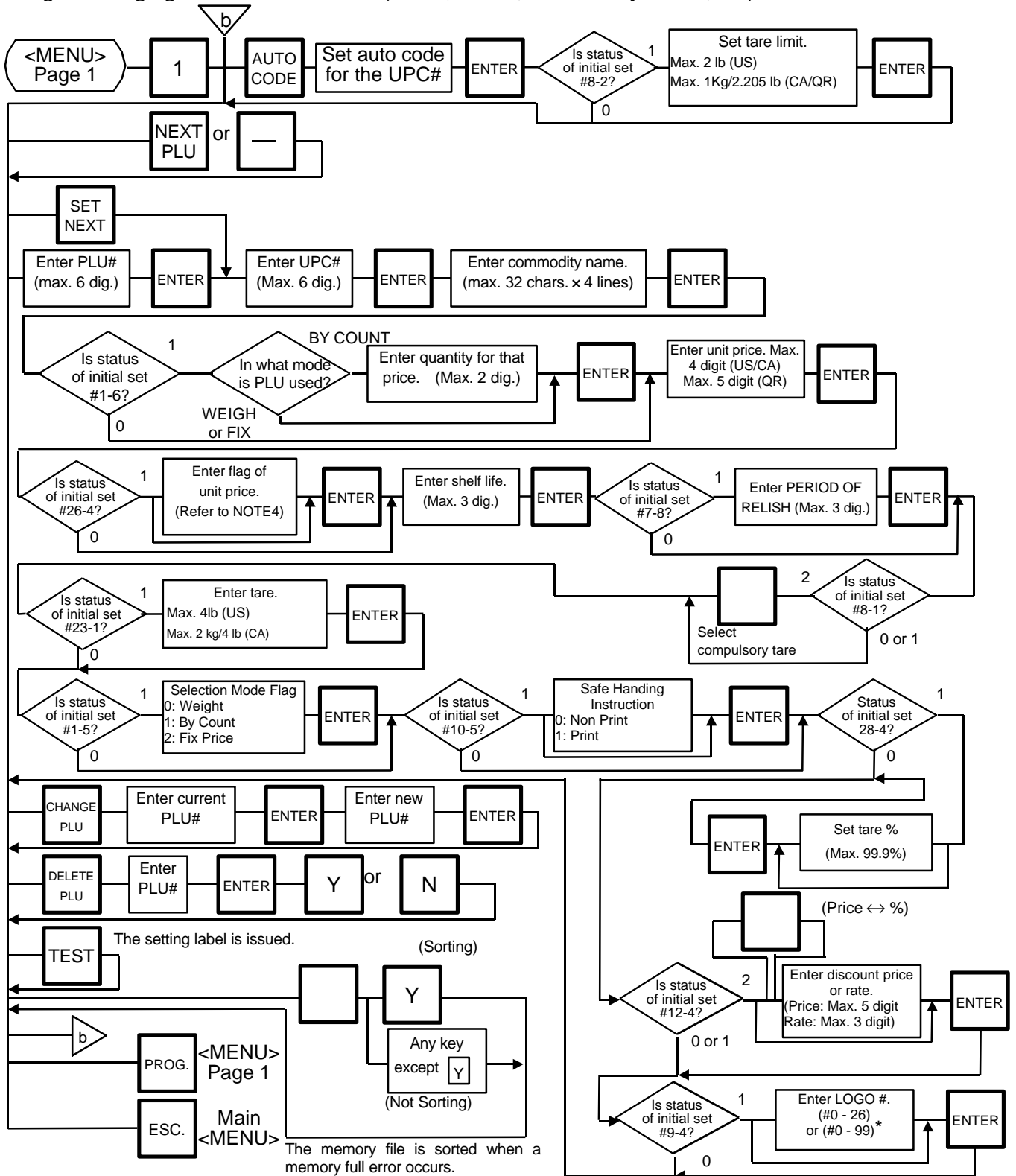

*: Selectable by the initial setting #10-7.

Pressing the key instead of the ENTER key proceeds to the next menu. Pressing the key returns to the preceding menu.
 Verification label of PLU data

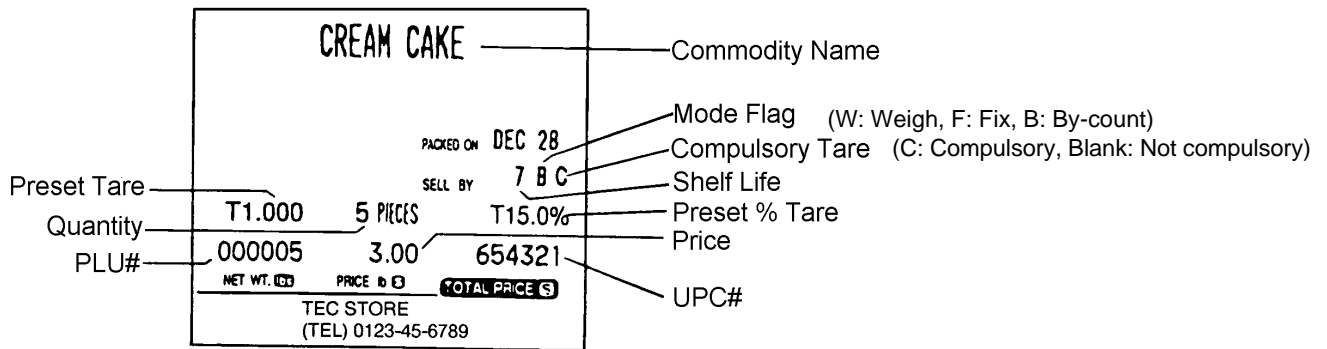

NOTES:

1. A UPC code is made up of a combination of an entered code and an AUTO CODE. Be sure to attach some characters to the end of the AUTO CODE, or all entered codes will be ignored and an AUTO CODE will become a UPC code (see ex. 1).

ex. 1) enter code: 456 ex. 2) enter code: 4567 ex. 3) enter code: 123456
 AUTO CODE: 123- - - AUTO CODE: 123- - - AUTO CODE: 987

code#: 123456

code#: 123567

code#: 987

2. When there is no area to store PLU data, an error occurs when pressing the ENTER key.
3. Changing a PLU # to the number to which other PLU data is already set will result in an error.
4. Unit price flag may be selected as follows:
 - 1) In case of lb scale
 - a. INSERT 1 key : \$ per lb
 - b. DELETE (A) 1/2 key : \$ per 1/2 lb
 - c. RETURN 1/4 key : \$ per 1/4 lb
 - 2) In case of kg scale
 - a. INSERT 1 key : \$ per 100 g or Kg
5. Tare limit should be a multiple of 1, up to 4.00 lb for US type and a multiple of 5, up to 2.000 Kg for CA type.
6. Safe handling instructions

Safe handling instructions is printed when the following label format # is selected.

<Format #>	<Number of ingredient lines printed>
57-mm wide labels	
13/63: POS-ING 18 lines	5
15/65: POS-ING 38 lines	25
16/66: POS-ING 37 lines	24
23/73: NET-ING 18 lines	5
25/75: NET-ING 38 lines	25
26/76: NET-ING 38 lines	25
33/83: B.C.-ING 18 lines	5
35/85: B.C.-ING 38 lines	25
36/86: B.C.-ING 38 lines	25
44/94: FSP-ING 8 lines	0
48: Variable length	Variable
41-43: Free Format	-
49: Rotation Label	8
80-mm wide labels	
23-73: NET-ING 22 lines	9
# 44/94: FSP-ING 8 lines	0
# 47/97: 960-ING 8 lines	0

*The normal safe handling instructions is equal to 13 lines of type-0 ingredients in size and wide one is equal to 8 lines of type-1 ingredients in size as marked #.

7. Tare % indicates a percentage of tare in gross weight, which is available when the Initial Setting #28-4 is set to 1.
8. When setting open prices in the count mode (Initial Setting #1-6: 1), set zeros as quantity and unit price.

10.3 INGREDIENT MESSAGE

Menu Page: 1
 Item No.: 2

Ingredient messages can be printed on a label with a maximum of 54 characters per line using small letters or 32 characters per line using boldfaced small letters by up to 38 lines.

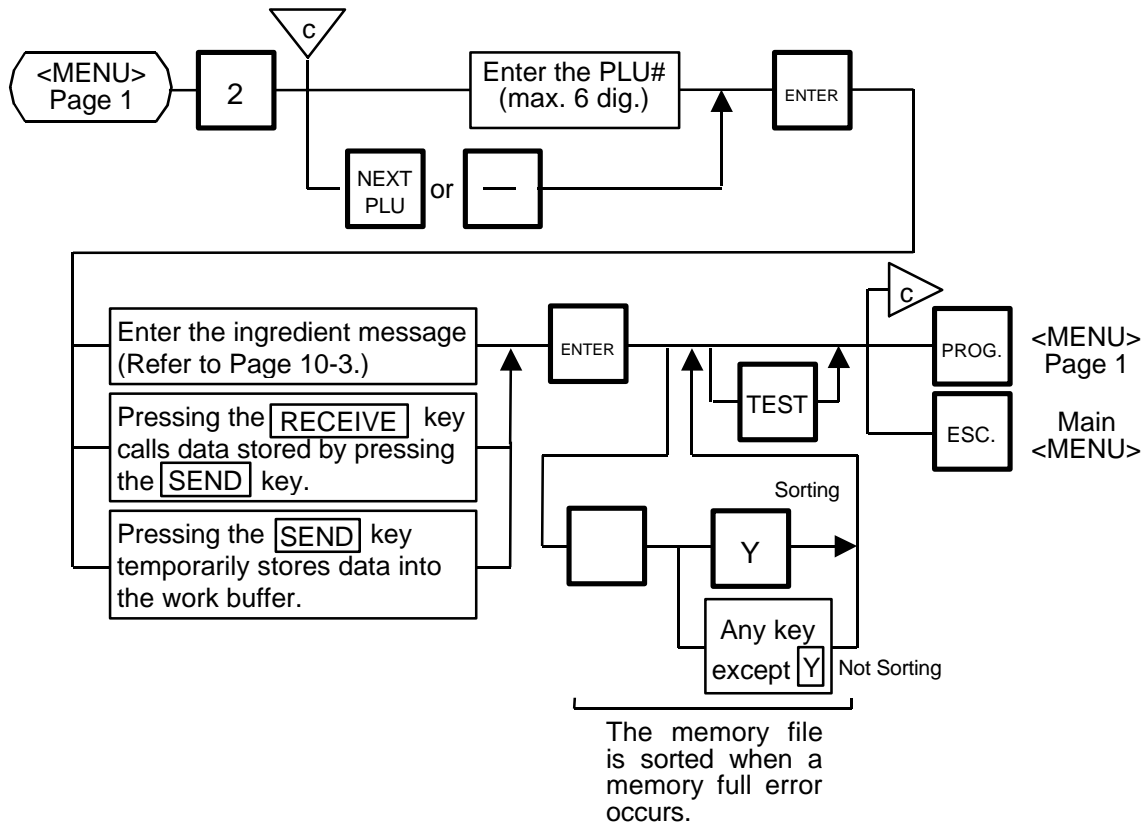

- NOTES:**
1. When no data is programmed for the PLU, ingredient cannot be set.
 2. When a selected PLU is not stored in the PLU file, a "PLU NOT FOUND" error occurs.
 3. Once you exit this menu and enter again, data stored in the work buffer is cleared.
 4. When there is no area to store ingredient data, a "MEMORY FULL" error occurs.
 5. Different PLUs cannot use the same ingredient data. (PLU and ingredient data are in pairs.)

10.4 NUTRITION FACTS

Menu Page: 1
 Item No.: 3

Using the following procedure, nutrition information and caloric intake can be set. Serving Size and Servings Per Container consist of a maximum of a 18 characters. However, total number of characters including title characters must not exceed 30.

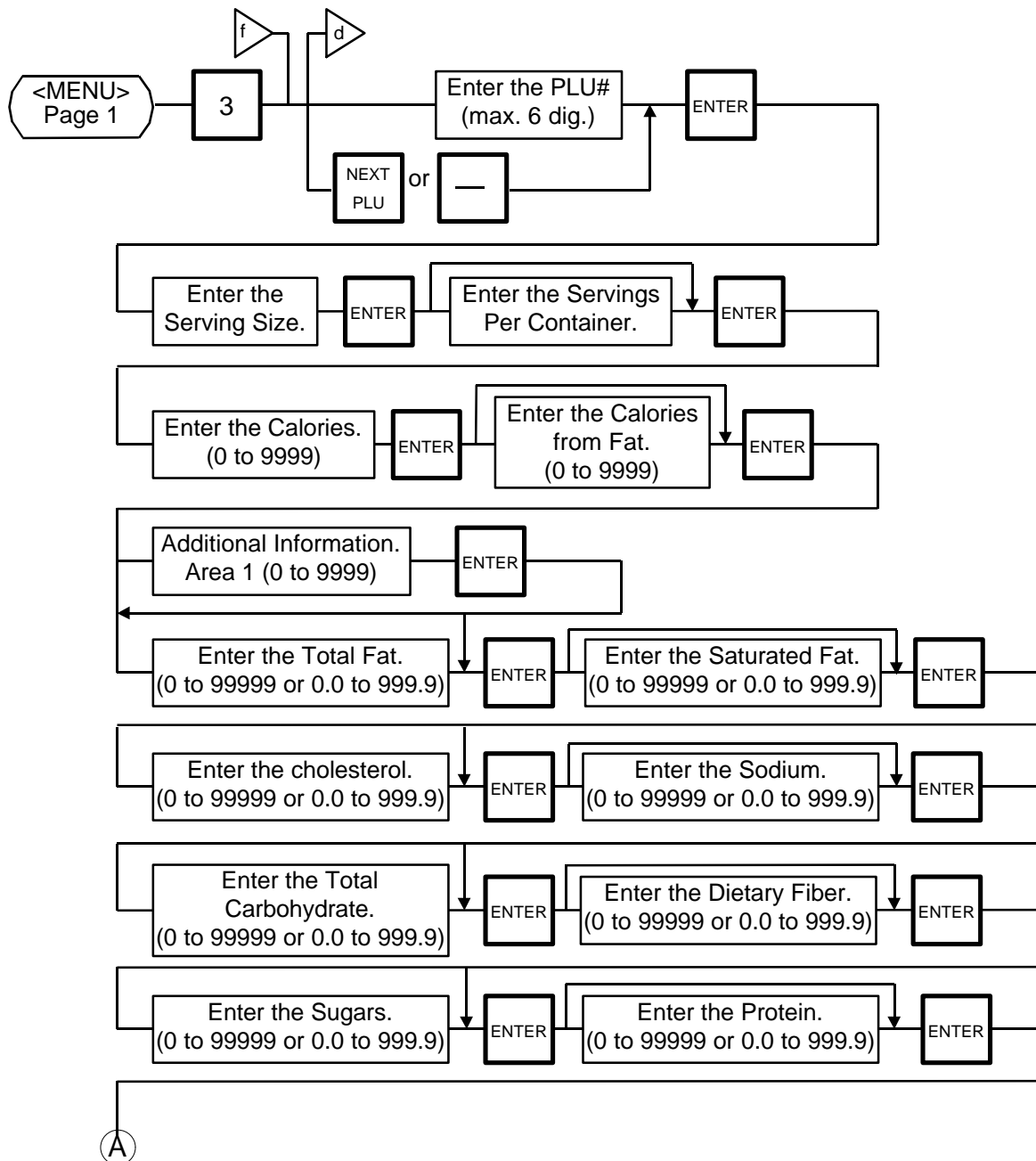

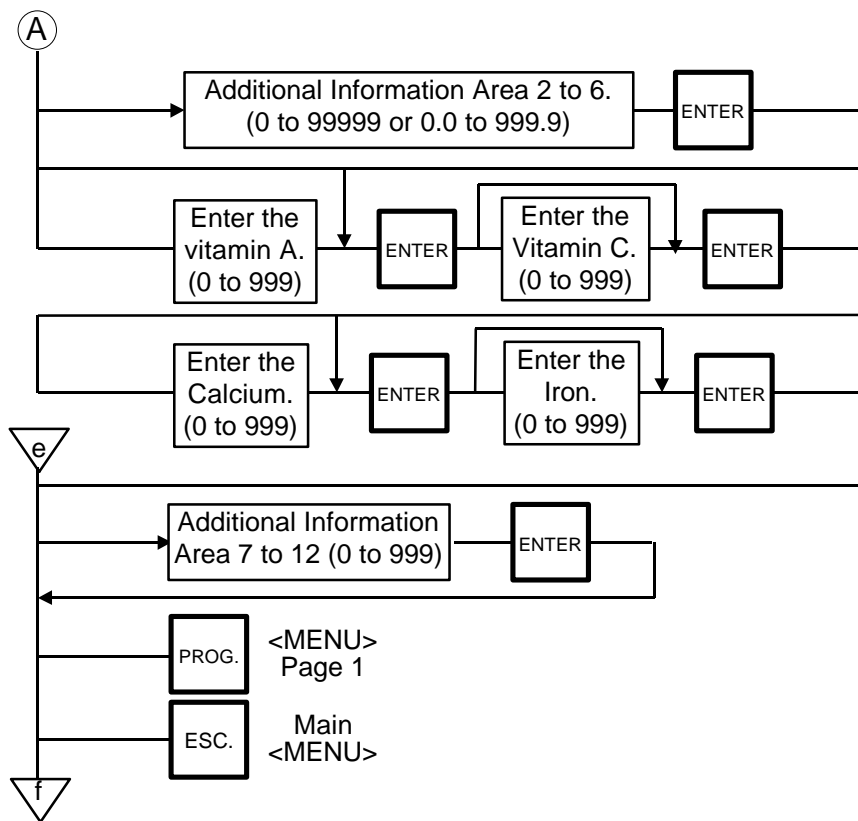

Pressing the key instead of the ENTER key advances to the next menu. Pressing the key returns to the preceding menu.

NOTES:

When entering a PLU#, be careful of the following.

1. When a selected PLU# is not stored in the PLU file, an error occurs.
2. Nutrition file is input each time the ENTER key is pressed. Thus, if you quit the procedure on the way, data entered without pressing ENTER key is not stored.
3. The additional information can be used only when its title has been registered in Section 10.17.

Set the Daily Value Table

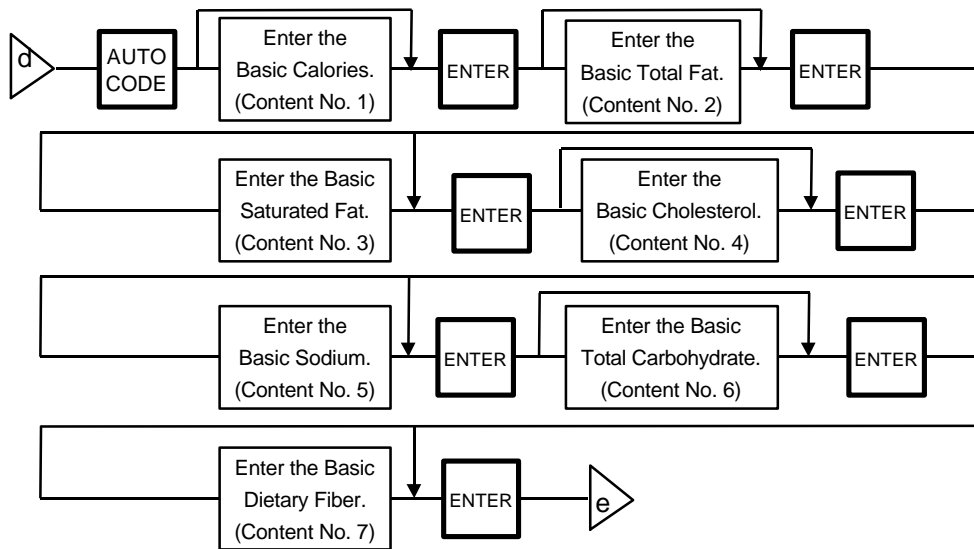

NOTES:

1. DAILY VALUE (Max. 8 digits)
 - 1) The contents of Daily value

Contents	upper 4 digits	lower 4 digits
No. 1	Percentage of necessary daily intake of Calories	Necessary daily intake of Calories
No. 2	Percentage of necessary daily intake of Total Fat	Necessary daily intake of Total Fat
No. 3	Percentage of necessary daily intake of Saturated Fat	Necessary daily intake of Saturated Fat
No. 4	Percentage of necessary daily intake of Cholesterol	Necessary daily intake of Cholesterol
No. 5	Percentage of necessary daily intake of Sodium	Necessary daily intake of Sodium
No. 6	Percentage of necessary daily intake of Total Carbohydrate	Necessary daily intake of Total Carbohydrate
No. 7	Percentage of necessary daily intake of Dietary Fiber	Necessary daily intake of Dietary Fiber

- 2) The necessary daily intake of calories can be changed by changing the above table data, and percentage will be changed accordingly.
2. Percentage of daily intake
 - 1) Percentage data are printed in right justified 3 digits with zero suppression.
 - 2) Under the following conditions, an error occurs and data will be printed as '- - - %'.
 - Percentage data exceeds 3 digits (999 %).
 - Data is entered improperly.
 - Other than x x x x x or x x x . x
 - Other than numerals (0 to 9) and a point '.'
 - 3) Calculation
 - (input data)/(necessary daily intake) × 100
 - = Percentage of daily value
 - (round the obtained data to one decimal place)

Deleting Nutrition Data

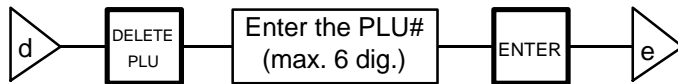

Memory file sort

The memory file is sorted when a memory full error occurs.

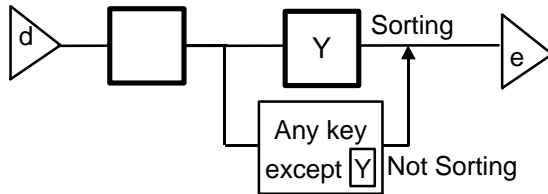

Nutrition Facts	
Serving Size	xxxxCUP (xxxxg)
Servings Per Container	xxx
Amount Per Serving	
Calories	xxxx
Calories from Fat	xxxx
xxxxxxxxxxxxxxxxxxxxxxxxxxxx	
% Daily Value*	
Total Fat	xxxxg xxx%
Saturated Fat	xxxxg xxx%
Cholesterol	xxxxmg xxx%
Sodium	xxxxmg xxx%
Total Carbohydrate	xxxxg xxx%
Dietary Fiber	xxxxg xxx%
Sugars	xxxxg
Protein	xxxxg
xxxxxxxxxxxxxxxxxxxxxxxxxxxx	
xxxxxxxxxxxxxxxxxxxxxxxxxxxx	
xxxxxxxxxxxxxxxxxxxxxxxxxxxx	
xxxxxxxxxxxxxxxxxxxxxxxxxxxx	
xxxxxxxxxxxxxxxxxxxxxxxxxxxx	
xxxxxxxxxxxxxxxxxxxxxxxxxxxx	
Vitamin A	xxx% Vitamin C xxx%
Calcium	xxx% Iron xxx%
xxxxxxxxxxxx xxx% xxxxxxxxxxxx xxx%	
xxxxxxxxxxxx xxx% xxxxxxxxxxxx xxx%	
xxxxxxxxxxxx xxx% xxxxxxxxxxxx xxx%	
* Percent Daily Values are based on a 2,000 calorie diet.	
1 st Address	-----
2 nd Address	-----

Additional information area 1
 Additional information area 2
 Additional information area 3
 Additional information area 4
 Additional information area 5
 Additional information area 6
 Additional information area 7,8
 Additional information area 9,10
 Additional information area 11,12

Nutrition Facts	
Serving Size	1234567890123
Servings Per Container	223
Amount Per Serving	
Calories	3
Calories from Fat	4
% Daily Value*	
Total Fat	5g 8%
Saturated Fat	6g 30%
Cholesterol	7mg 2%
Sodium	8mg 0%
Total Carbohydrate	9g 3%
Dietary Fiber	10g 40%
Sugars	11g
Protein	12g
Vitamin A 13%. Vitamin C 14%	
Calcium 15%. Iron 16%	
* Percent Daily Values are based on a 2,000 calorie diet.	
1-00000000000000000000000000000000-1	
2-00000000000000000000000000000000-2	

- Area for titles
- Area for entry data: Set in this menu (Nutrition Setting procedure)
- Area for data: Calculated on the basis of the entered data in Menu Page 1/Item No.3

10.5 PLU VERIFYING LABEL

Menu Page: 1
Item No.: 4

PLU data stored in the scale are verified in the following procedure.

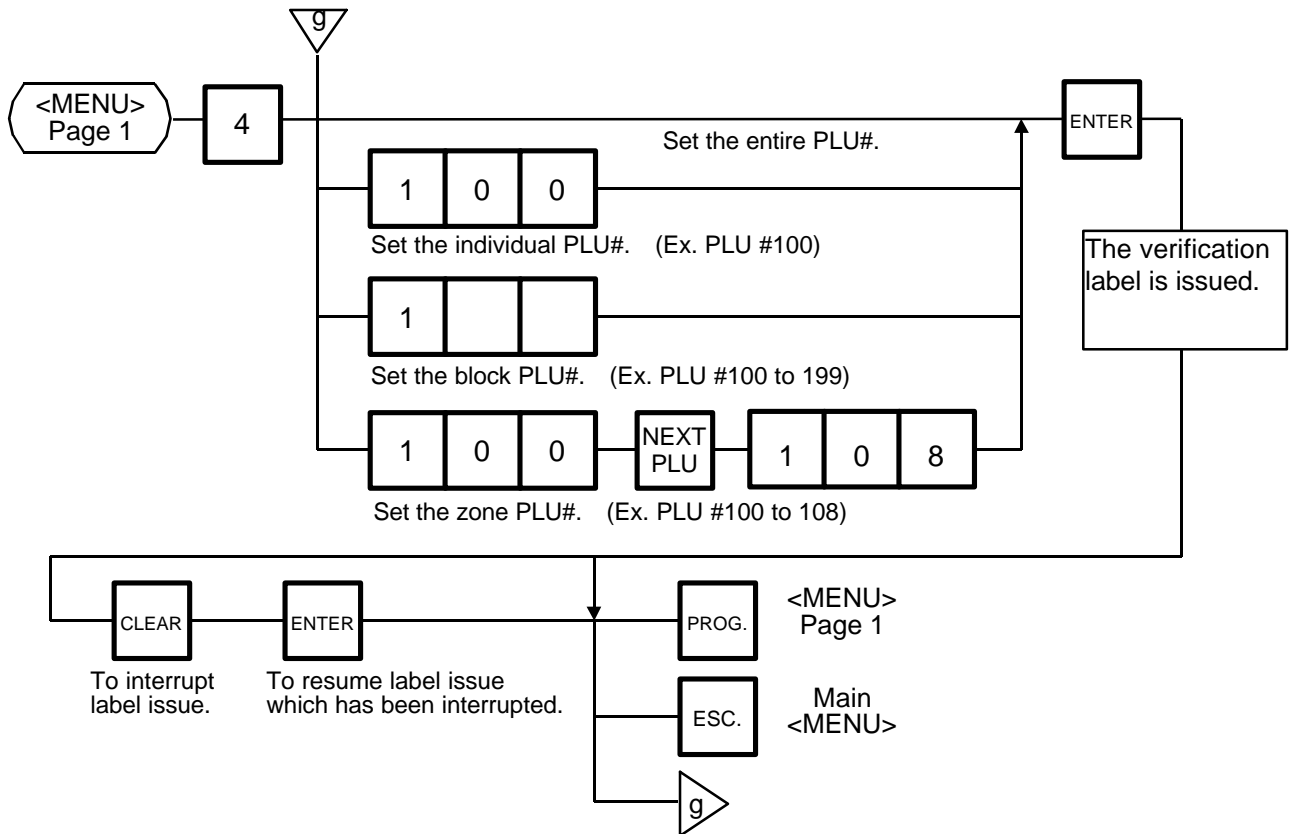

NOTES:

1. Labels are printed in either batch mode or on-demand mode.
2. When no PLU is stored in the selected range, an error occurs when the **ENTER** key is pressed.
3. Pressing the **CLEAR** key releases the scale from the error mode and returns to the initial status of this menu.
4. After clearing a paper jam error, the scale will wait for an entry of PLU# again.

10.6 ADDRESS AND COMMERCIAL MESSAGE SETTING

Menu Page: 1
 Item No.: 5

A store address printed on label and a commercial message shown on the display can be set within the following character limits using the procedure below.

Address: 32 characters x 2 lines

Message: 90 characters

Receipt Header: 24 characters in the 1st/2nd line and 48 characters in the 3rd line

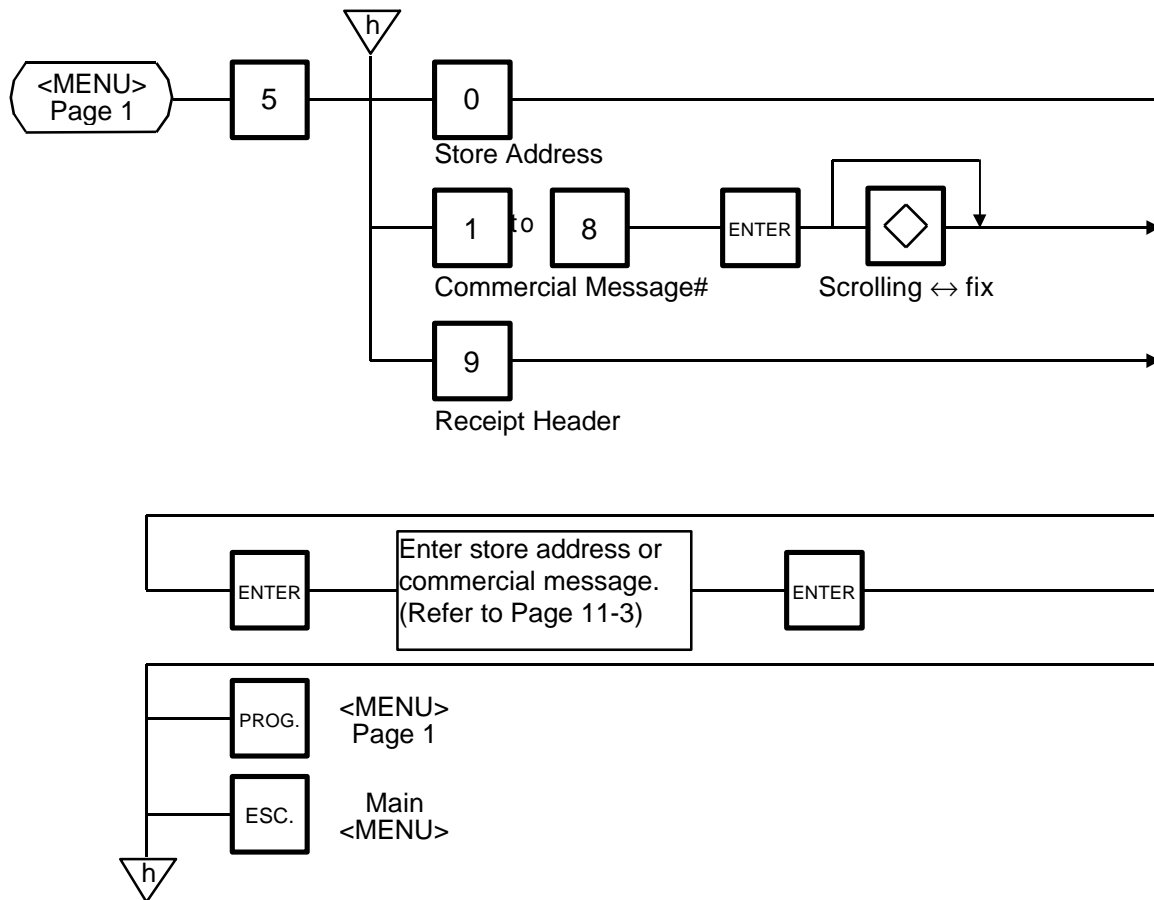

NOTE: When the fixed message is selected, the first 16 characters will be indicated on the display.

10.7 COMBINATION MESSAGE

Menu Page: 1
Item No.: 6

You can combine some messages set in Section 11.6 together and create a maximum of 24 different combination messages.

Message construction

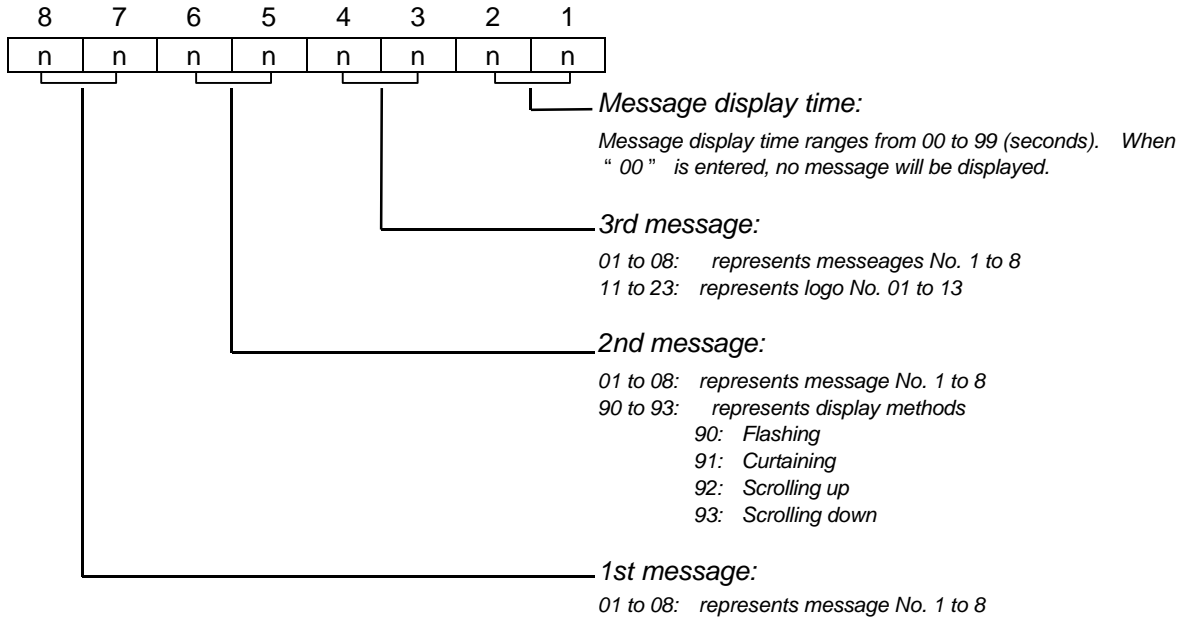

NOTE: When the fixed message is selected, set "00" as the 1st and 2nd messages. Otherwise, set "00" as the 1st message. When the Flashing, Curtaining, Scrolling up or Scrolling down is selected, set "00" as the 1st message.

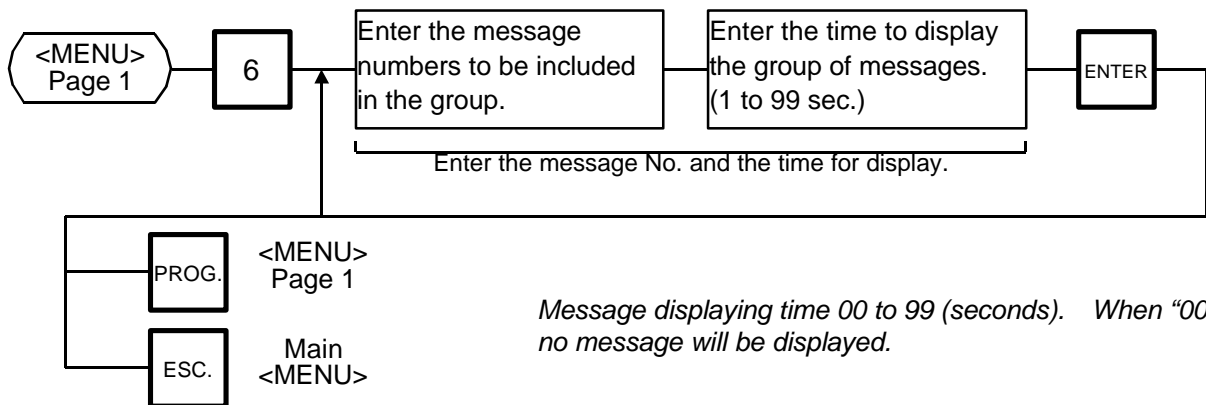

NOTE: The combination No. is selected as follows by **ENTER** key.



3. Display method varies depending on message construction.
 - 1) message combination
 - a. single message either scrolling or fixed is available.
 - b. multiple message scrolled regardless of selection.
 - 2) logo combination
Logo must be a single logo and a fixed display. When logos are combined, no message will be displayed.
 - 3) combination of message and logo
It is prohibited. When both a message and logo are combined together, only message will be displayed.

4. You can press the **PROG.** and the **ESC.** keys to exit the procedure at any time. However, no data will be stored without pressing the **ENTER** key.

5. Display method

1) Fixed

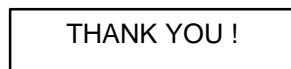

2) Scrolling

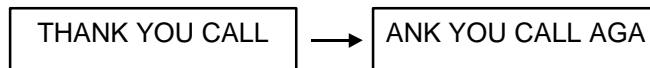

3) Flashing

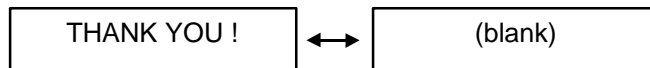

4) Curtaining

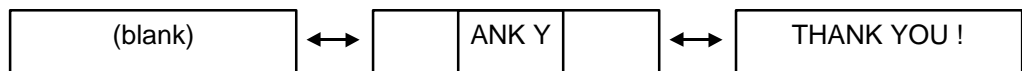

5) Scrolling up

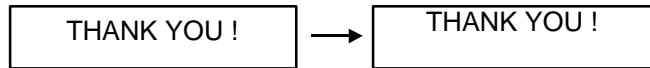

6) Scrolling down

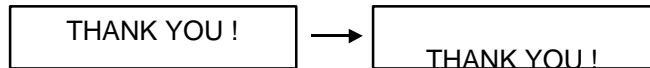

NOTE: The scrolling up/down methods allow displaying 16 characters per line, up to a total of 90 characters per display.

10.8 SPECIAL INFORMATION

Menu Page: 1
 Item No.: 7

When the Net Weight Statement label is selected, 3 lines (32 characters/line) of special information can be printed on the label position where the net weight data is to be printed. The special information can be printed in the weigh and By Count mode. In the Fix mode, the net weight data is printed.

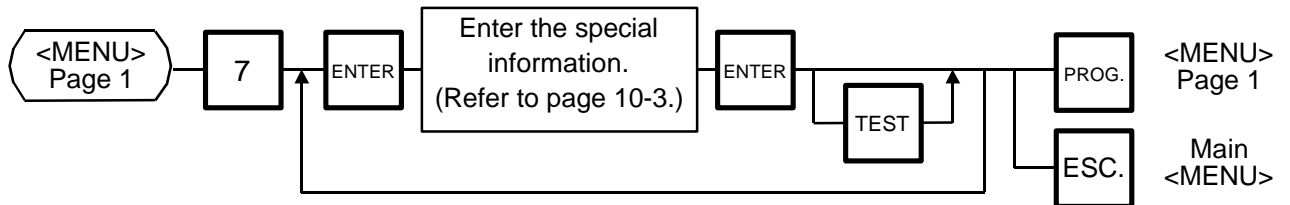

10.9 GRADE LINE

Menu Page: 1
 Item No.: 8

You can set the maximum of 49 kinds of grade lines (max. 32 characters/line), and call one of them to print on the label.

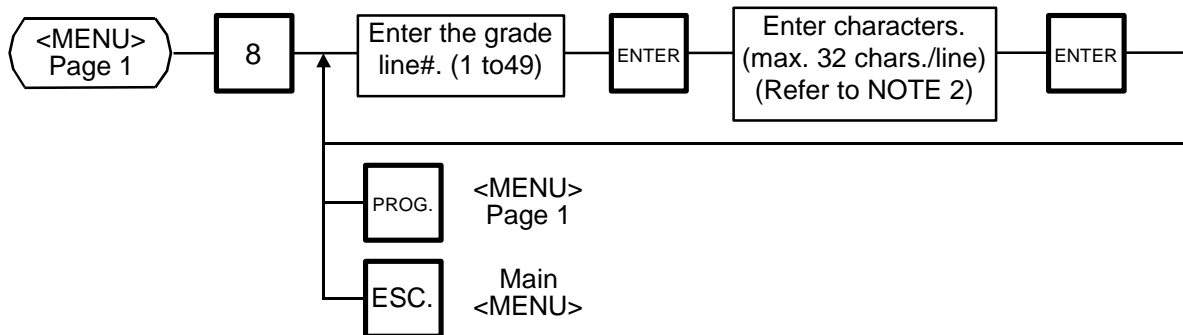

NOTES:

1. Print position of grade line can be changed by initial setting.
2. Refer to page 10-3, for information regarding how to enter the Grade Line.

10.10 SPEED KEY SETTING

Menu Page: 1
 Item No.: 9

The H-9100N has a maximum of 108 x 2 speed keys which are very convenient to call PLUs quickly. (Refer to page 5-3 regarding the Key Layout.)

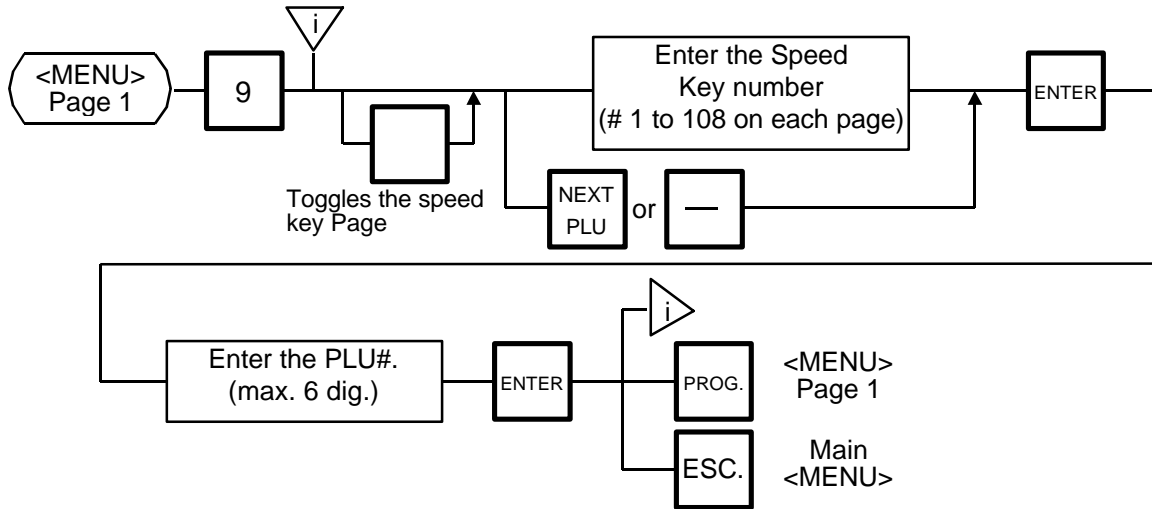

Setting Department/Vendor Number

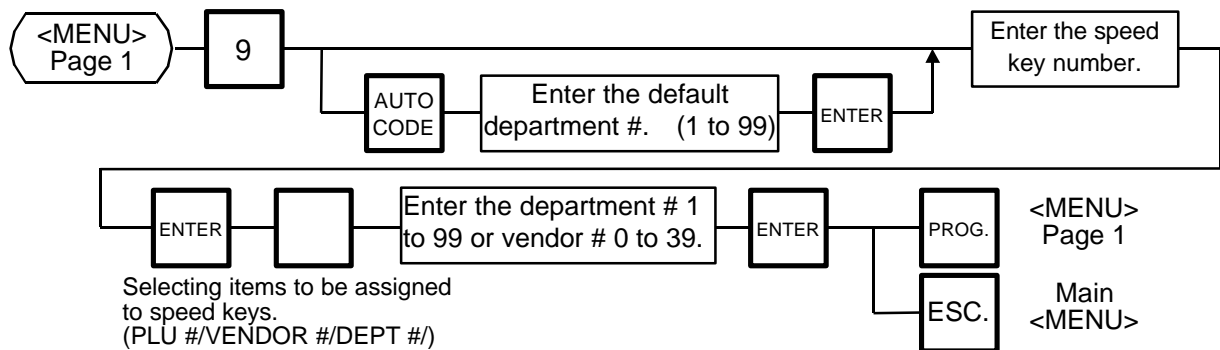

Department Number

When initial set #10-6 is set to "1", the six-digit PLU # is divided into two; the upper two digits are assigned to department #, and the lower four digits to PLU.

The department # is automatically added in the front of the four-digit PLU # and treated as a six-digit PLU #.

In case of "PROG.", "Report", and "Reset" modes, PLU # is treated as a six-digit number. So the upper two digits are not treated as department #. Consequently the four-digit PLU # is available only in "REG.", "M.DOWN", and "REWRAP" modes.

NOTE: The default Dept No. is a two-digit serial number ranging from 0 to 99. Entering a "0" clears a Dept. No.

Vendor Number

Vendor numbers can be set when the Initial Setting #11-1 is set to 1.

Vendor numbers are assigned to the speed keys in two ways:

Individual vendor number: 00-39

Vendor # is assigned to the speed keys one by one.

Group vendor number: 0-, 1-, 2- and 3-

Maximum 10 vendor numbers can be assigned to one speed key, resulting in 4 speed keys in total. When assigning group vendor numbers to the speed keys, enter the first digit of the vendor key (0, 1, 2 or 3) plus a bar (-).

10.11 PRINT FORMAT

Menu Page: 2

Item No.: 0

The H-9100N can memorize 5 different print formats. After the print formats are set, you can call them by pressing the print format number.

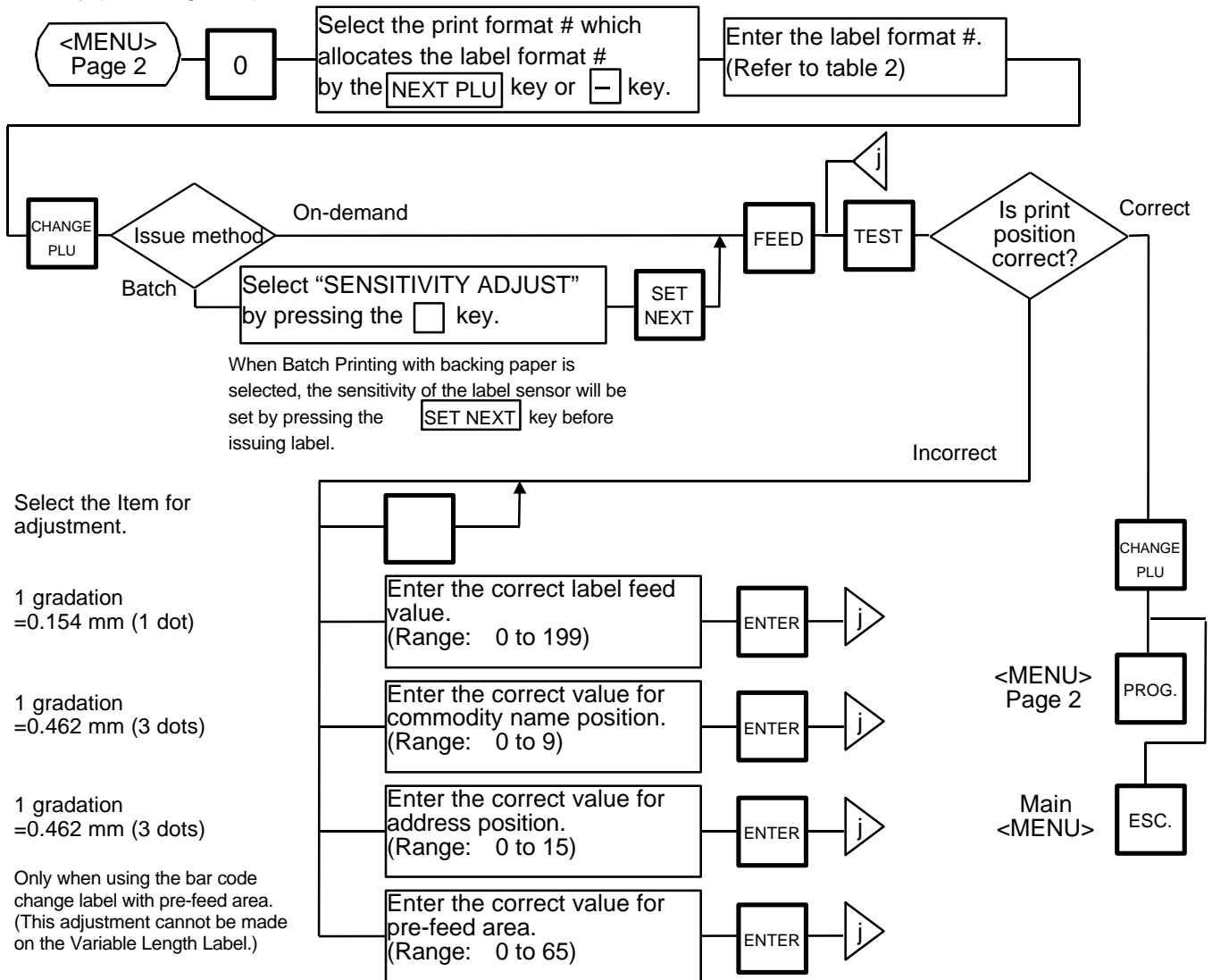

NOTES:

1. When a commodity name position is adjusted, an address position will move automatically.
2. When entering the other label format #, fine adjust values are initialized.
3. Selecting label format numbers other than those provided in Table 2 results in an error.
4. When selecting a variable length label format, rectangles are printed instead of print items in the case of the test printing.
5. Pressing the [] key allows you to select a print format number from 1 to 5.
6. Be sure to press the [SET NEXT] key when a label format for batch printing with backing paper is selected.

Table 2: Label Format Number Table

Select the format # for the label to be used by referring to the table below.

Format #	Print format			57-mm wide label				80-mm wide label			
	Basic form	Ingredient	Commodity		Length	Nutri.	F.S.		Length	Nutri.	F.S.
10 (60)	POS	0 lines	4 lines	Yes	49.2	No	No	Yes	47.6	No	No
11 (61)		8 lines	4 lines	Yes	63.5	No	No	Yes	56.4	No	No
13 (63)		22 lines	4 lines	Yes	92.8	No	No	No			
15 (65)		38 lines	4 lines	Yes	138.1	No	No	No			
16 (66)		37 lines	4 lines	Yes	138.1	Yes	No	No			
21 (71)	NET WT.	8 lines	4 lines	Yes	85.7	No	No	No			
23 (73)		22 lines	4 lines	Yes	112.7	No	No	Yes	88.9	No	No
25 (75)		38 lines	4 lines	Yes	158.7	No	No	No			
26 (76)		38 lines	4 lines	Yes	158.7	Yes	No	No			
31 (81)	BOTTOM BARCODE	8 lines	4 lines	Yes	96.8	No	No	No			
33 (83)		22 lines	4 lines	Yes	123.8	No	No	No			
35 (85)		38 lines	4 lines	Yes	171.4	No	No	No			
36 (86)		38 lines	4 lines	Yes	171.4	Yes	No	No			
41 (91)	FREE FORMAT		4 lines	Yes	Max.195	No	Yes	Yes	Max.135	Yes	Yes
42 (92)				Yes	Max.195	No	Yes	Yes	Max.135	Yes	Yes
43 (93)				Yes	Max.195	No	Yes	Yes	Max.135	Yes	Yes
44 (94)	FSP FORMAT	13 lines (57mm) Wide C/G 8 lines (80mm)	2 lines (57mm) 4 lines (80mm)	Yes	85.7	No	Yes	Yes	79.4	No	Yes
45 (95)	ALL IN ONE FORMAT	36 chr. x 12 lines	4 lines	No				Yes	112.7	Yes	No
46 (96)	ALL IN ONE (ROTATION)	36 chr. x 12 lines	4 lines	No				Yes	112.7	Yes	No
47 (97)	960 FORMAT	Wide C/G 8 lines	2 lines	No				Yes	68.8	No	No
48	VARIABLE LENGTH FORMAT		4 lines	Yes	Variable	Yes	Yes	No			
49	ROTATION	21 lines	4 lines	Yes	Variable	Yes	Yes	No			

NOTE:

Format No.

0 0

- 0: 0 ingredient line
- 1: 6 ingredient lines (Except free format)
- 2: 12 ingredient lines (Except free format)
- 3: 18 ingredient lines (Except free format)
- 4: 22 ingredient lines
- 5: 38 ingredient lines
- 6: Ingredient + Nutrition on white label with symbols
- 7: 960 format
- 8: Variable length
- 9: Variable length + rotation

- 0: NON POS (On demand print)
- 1: POS (On demand print)
- 2: NET WT. Statement (On demand print)
- 3: Bottom barcode (On demand print)
- 4: Other than 0 to 3 (On demand print)
- 5: NON POS (Batch print on labels with back paper)
- 6: POS (Batch print on labels with back paper)
- 7: NET WT. Statement (Batch print on labels with back paper)
- 8: Bottom barcode (Batch print on labels with back paper)
- 9: Other than 5 to 8 (Batch print on labels with back paper)

10.12 DATE/TIME SETTING

Menu Page: 2
Item No.: 1

Date, time, machine number, and store code are set with this procedure.

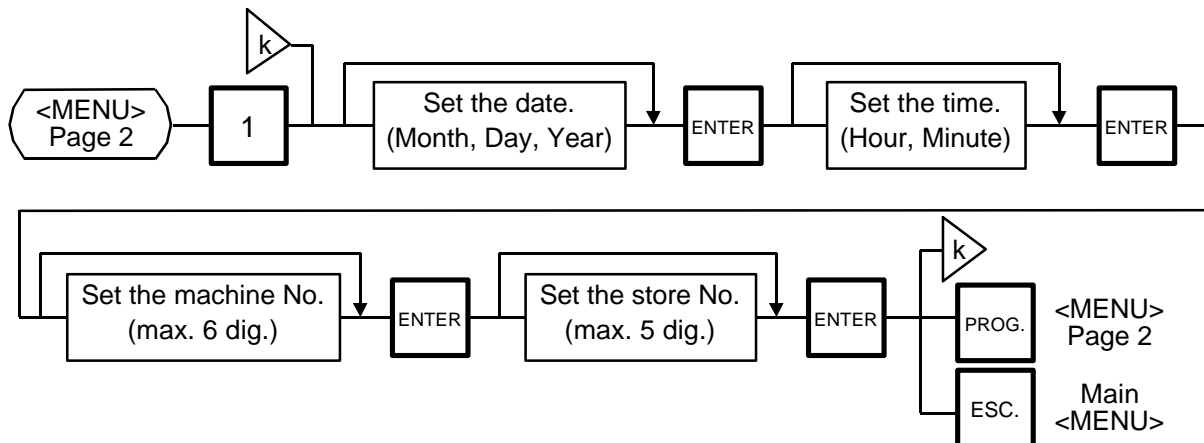

NOTES:

1. Express the time in a 24-hour military format.
2. The H-9100N will check details of date (time) input, and any wrong date (time) will result in an error mode. Then the correct date (time) should be re-entered and press the **CLEAR** key.
3. Even when initial Setting# 8-4, 8-5 or 8-6 is set to the " Julian Date " side, the way to enter the date in the date setting operation is the same as in the ordinary case.
4. The date display method can be changed by the initial setting.

10.13 CMT/PL-3

Menu Page: 2
Item No.: 2

CMT Operations

The H-9100N is designed to interface with a Cassette Magnetic Tape loader. This loader allows the transfer of the entire PLU file, ingredient file and other data from the H-9100N to tapes. This can be accomplished in number of operation steps.

In turn, information from the tape can also be transferred to another H-9100N scale.

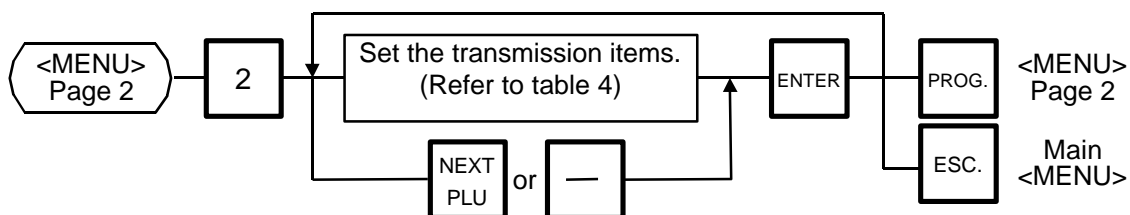

NOTES:

1. The error mode can be released by pressing the **CLEAR** key, and you can operate again through the above steps.
2. Use the metal cassette tape which is commercially available and has a capacity of 45 or 60 minutes recording.
3. For operations of the CMT loader, refer to the instruction manual provided with the CMT loader.

PL-3 Operation

Connect the PL-3 to the H-9100N by using RS-232C Cable, then turn on the power of the H-9100N and the PL-3.

Insert a data disc into the PL-3 and adjust the transmission rate to the H-9100N (**7 2** :4800 BPS or **7 3** : 2400 BPS) by using the rotary switch.

Press the **SAVE** key of the PL-3, then check whether the SAVE LED is on.

Program the file number of the data disc by using the rotary switch.

(**4 1** : File No. 1, **4 2** : File No. 2, **4 8** : File No. 8, **4 9** : File No.9)

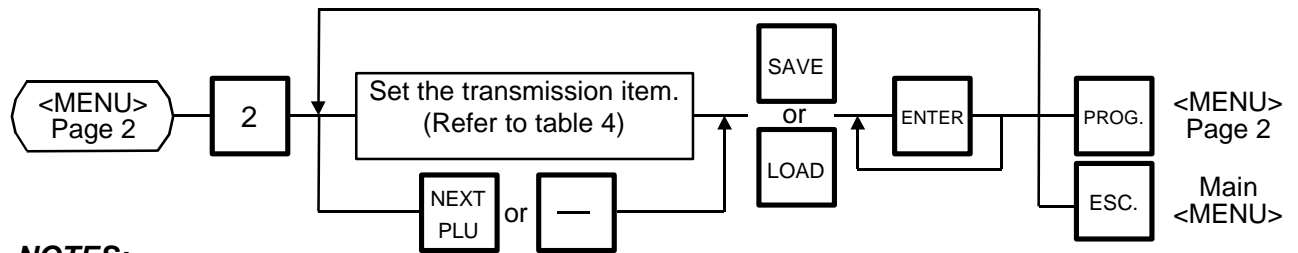

NOTES:

1. Press the **SAVE** or the **LOAD** key on the PL-3.
2. In the **ENTER** Key is not pressed within 10 seconds after the **SAVE** or the **LOAD** key is pressed, a Time Out Error results.
3. After pressing the **ENTER** key, the operation ends when "00" appears in the 7 seg. display and LAMP goes off. Remove the data disc and turn the power off.
4. Be sure to start the PL-3 before the main operation.

Table 3: Error code for PL-3 operation

Error Code	Error Message	Error Code	Error Message
1	0 FDC ERROR	3	7 FRAMING ERROR
	1 FDK MISINSERTION ERROR		8 PARITY ERROR
	2 UNAVAILABLE FDK INSERTION ERROR	7	0 DATA ERROR
	3 VOL. LABEL UNMATCH ERROR		1 STATUS ERROR
	4 FDK MEMORY FULL ERROR		2 TIME OUT ERROR
	5 WRITE PROTECT ERROR		3 FDK READ/WRITE ERROR
	6 NO SEARCH FILE ERROR	F DESIGNATED SELECT KEY ERROR	
3	1 TIME OUT ERROR	8	0 RAM READ/WRITE ERROR
	2 LOAD ERROR		1 ROM CRC ERROR
	3 FDK ERROR		2 RAM BACK UP BATTERY ERROR
	4 BUSY STATUS		3 FDC DIAG LEVEL 0 ERROR
	5 POWER FAIL ERROR		E SYSTEM FDK LOADING ERROR
	6 OVERRUN ERROR		F SYSTEM ERROR

- 1) When the error code is FF, this system enters stop mode. (Turn the power off/on for release.)
- 2) When the error code is F2 or FE, perform the status clear (**9 9**).
- 3) If an error occurs, refer to the PL-3 Owner's Manual to solve the problem.

Table 4: Transmission Item List

ITEM #	Title on the Display	Contents of Transmission	CMT	PL-3
2	VERIFY PLU & ING. = CMT 2	COMPARE PLU & ING. IN OLD FORMAT		
3	READ PLU & ING. FM CMT 3	READ PLU & ING. IN OLD FORMAT		
4	WRITE PLU TO CMT 4	SAVE PLU IN NEW FORMAT		
5	VERIFY PLU = CMT 5	COMPARE PLU IN NEW FORMAT		
6	READ PLU FROM CMT 6	READ PLU IN NEW FORMAT		
7	WRITE ING. TO CMT 7	SAVE ING. IN NEW FORMAT	x	
8	VERIFY ING. = CMT 8	COMPARE ING. IN NEW FORMAT	x	
9	READ ING. FROM CMT 9	READ ING. IN NEW FORMAT	x	
10	WRITE NUTRI. TO CMT 10	SAVE NUTRITION IN NEW FORMAT		
11	VERIFY NUTRI. = CMT 11	COMPARE NUTRITION IN NEW FORMAT		
12	READ NUTRI. FM CMT 12	READ NUTRITION IN NEW FORMAT		
13	WRITE SPEED KEY 13	SAVE SPEED KEY IN NEW FORMAT		
14	VERIFY SPEED KEY 14	COMPARE SPEED KEY IN NEW FORMAT		
15	READ SPEED KEY 15	READ SPEED KEY IN NEW FORMAT		

: operable, x : inoperable

NOTE: When the PL-3 is required, FDK varies depending on the volume of ING. data.
Be careful of the following when changing a FDK.

a: During the write operation, replace the FDK with a formatted one.

b: Verify and read data in the same order as the write.

To cancel to change a FDK, press the CLEAR key.

10.14 IN-LINE/LOCAL

Menu Page: 2

Item No.: 3

When the H-9100N is used as a satellite in an in-line system, the “ID #” and “Transmission delay time” can be set by the following procedure.

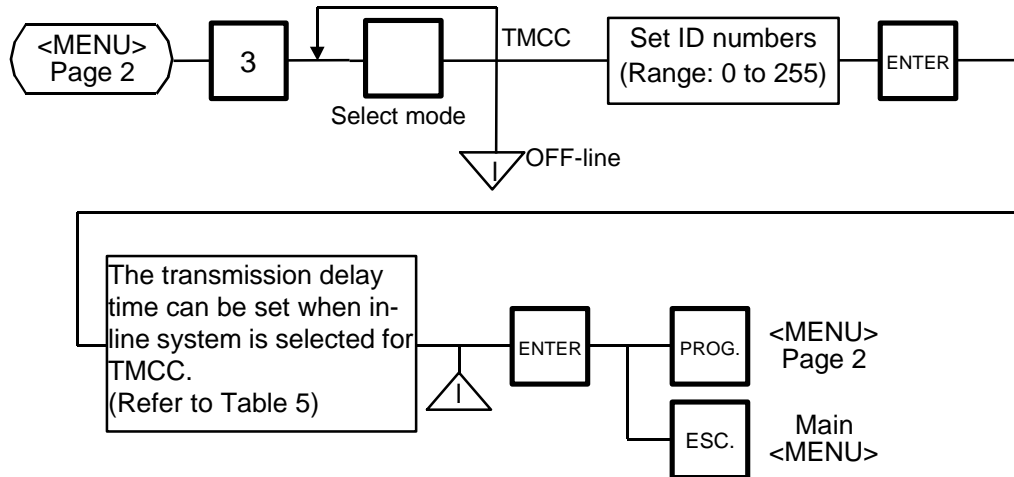

NOTES:

1. The TMCC baud rate is fixed to 4800 BPS.
2. After setting the ID #, turn the power switch OFF and ON again.
3. This setting is not available when the Initial set #13-6 is set to 1 (LAN: allowed).

Table 5: Transmission Delay Time Table

	TR-Time (ms)		TR-Time (ms)
1	20 to 39	6	120 to 139
2	40 to 59	7	140 to 159
3	60 to 79	8	160 to 179
4	80 to 99	9	180 to 199
5	100 to 119		

The default is 3.

10.15 LON SYSTEM

Menu Page: 2

Item No.: 4

The H-9100N scale printer which consists of a master, satellites, and a backup master is connected with each other by the LON cable to transmit data such as PLU, ING., NUTRI, etc.

ID# 1 is reserved for the master terminal.

ID# 2 is reserved for the backup master terminal or satellite terminal.

ID# 3 to 32 are for satellite terminals.

Setting numbers other than the above results in an error.

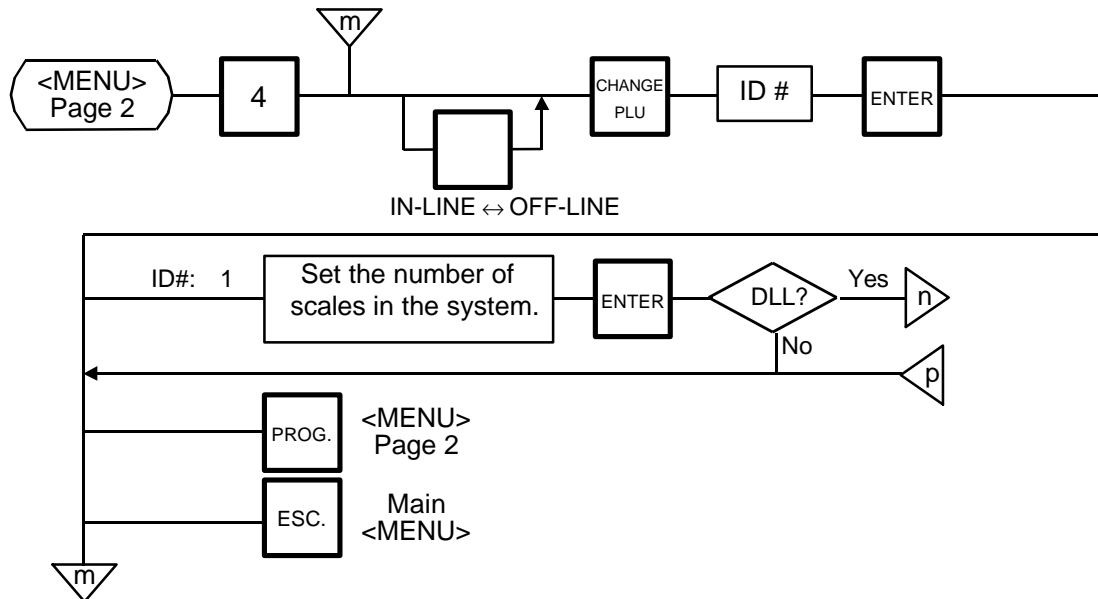

NOTES:

1. Before starting the above procedure, press the  key to enter IN-LINE mode.
2. When installing the backup master terminal, set the master scale's initial status of #9-1 to 1.
3. Set ID # to all scales in a LON system.
4. When the display power is turned on, the satellite terminal is ready to receive data from the master terminal.
5. After setting the ID #, turn the power switch OFF and ON again.

Data Transmission

The following data are down-line-loaded.

Page 1: (0). All (PLU+ING+NUTRI)

- (1). PLU
- (2). ING.
- (3). NUTRITION
- (4). U. PRICE
- (5). DATE/TIME
- (6). MESSAGE LINK (Message)
- (7). LOCK SCALE (Check the LON cable)
- (8). OPEN SCALE (Release the lock after checking the LON cable.)
- (9). CHANGE PAGE

Page 2: (0). SPEED KEY

- (1). LOGO
- (2). VENDOR
- (3). FREE FORMAT
- (4). ADDRESS
- (5). INITIAL
- (9). CHANGE PAGE

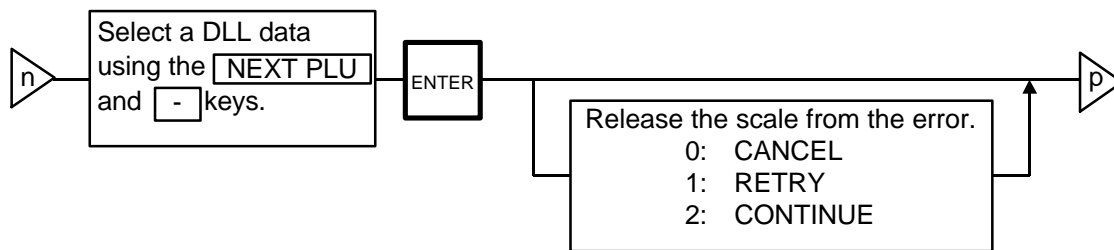

NOTE: DLL is performed automatically in the following two ways. It is selectable by the Initial Settings #0-6 and #0-7.

(1) LOCK SCALE method

Step 1: "LOCK SCALE" is sent. (*1)

Step 2: Selected data is sent. (*2)

Step 3: "OPEN SCALE" is sent.

*1: If an error occurs during step 1, the error terminal ID# is indicated. Select "cancel", "retry" or "continue" to release the terminal from an error.

cancel: Quits the operation after sending "OPEN SCALE"

retry: Tries to send "LOCK SCALE" again.

continue: Ignores the error terminal and starts DLL.

*2: If an error occurs during step 2, the error terminal ID# is indicated.

Press the [CLEAR] key to return to the DLL data selection menu.

(2) Background DLL

Step 1: Selected data is sent. (*3)

*3: If an error occurs, the error terminal ID# is indicated. Press the [CLEAR] key to return to the DLL data selection menu.

10.16 BAR CODE FORMAT

Menu Page: 2
Item No.: 6

With the H-9100N scale, four kinds of bar code formats are available. These formats can be changed freely.

Example)

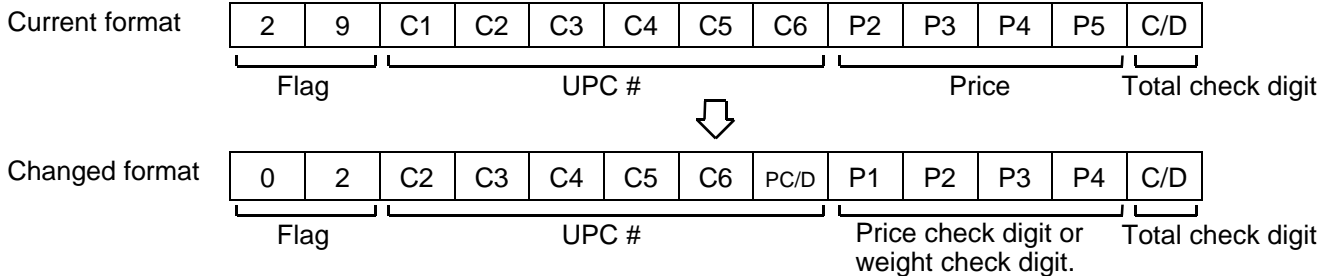

When changing the above example format into the weigh format described in NOTE 1, use the following procedure.

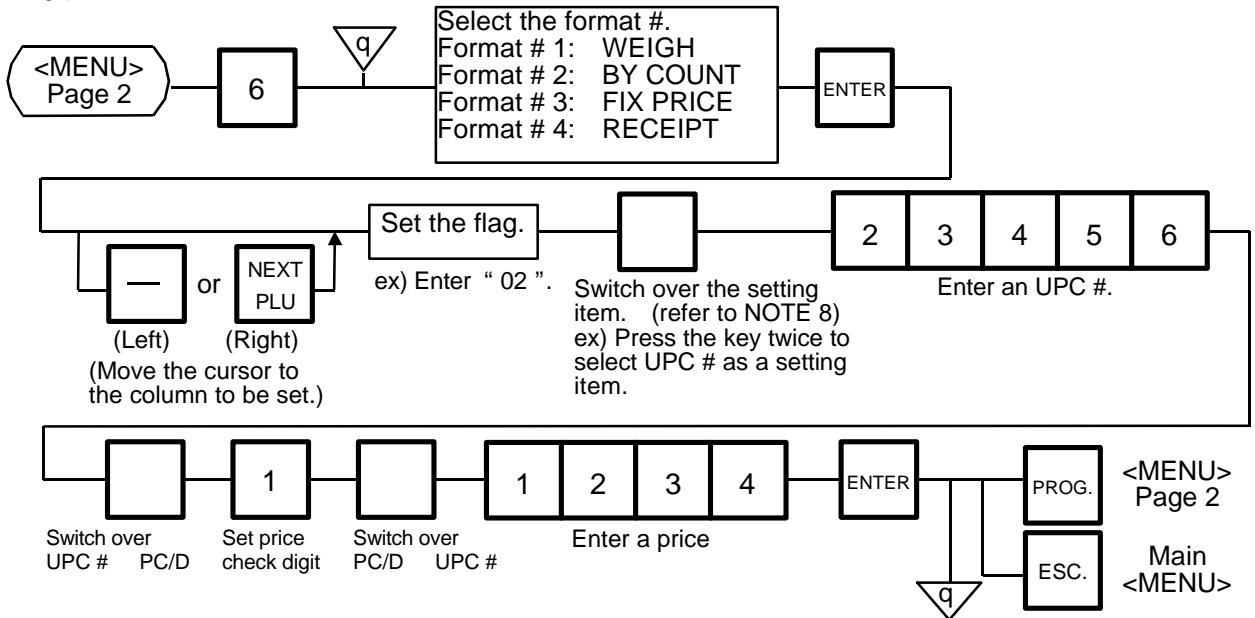

NOTES:

1. In this scale, the previously set bar code format is initialized to the following default by RAM clear.

Default Bar Code Format:

Weigh or Fix Price Format

0	2	C2	C3	C4	C5	C6	PC/D	P1	P2	P3	P4	C/D
---	---	----	----	----	----	----	------	----	----	----	----	-----

By Count Format

0	0	0	C2	C3	C4	C5	0	0	0	0	C6	C/D
---	---	---	----	----	----	----	---	---	---	---	----	-----

Receipt Format

0	2	0	0	0	0	PC/D	P1	P2	P3	P4	P5	C/D
---	---	---	---	---	---	------	----	----	----	----	----	-----

2. When the **ENTER** key is pressed, bar code format is checked. An error occurs in the following cases.

Check digit (C/D) is at other than digit-13.

Price check digit (PC/D) cannot be calculated. (Price is other than 4 or 5 digits.)

Price is not set serially beginning from P1 (P1 to P4, or P1 to P5).

Weight is not set serially beginning from W1 (W1 to W5).

3. The usable keys to set the column are as follows:

FLAG	0 to 9
PLU #	1 to 6
UPC #	1 to 6
PC/D	1
PRICE	1 to 7
WEIGHT	1 to 6
C/D	1

4. Digits and display of PLU #

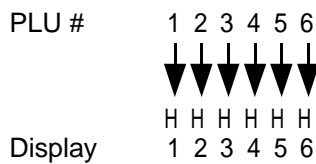

5. Digits and display of UPC #

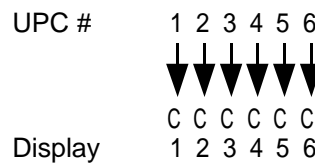

6. Digits and display of price

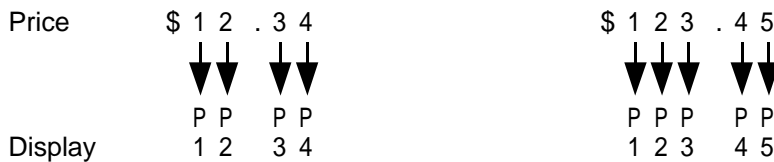

7. Display of weight digits

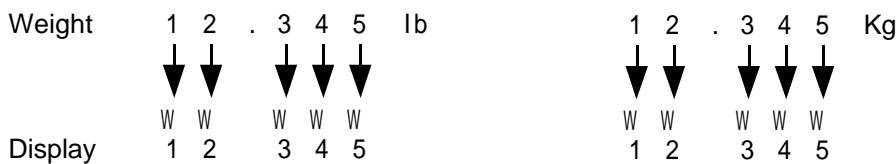

8. Setting Items

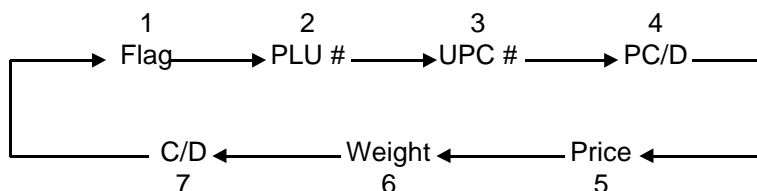

10.18 TRANSFERRING LOGO DATA

Menu Page: 2
Item No.: 8

Logo data is created on a PC and stored into RAM through the CMT interface. Two different sizes of logos, 320 x 118 dots and 256 x 64 dots, are available on the H-9100N series. 64 KB of RAM area is secured for logo data, in which the maximum of 13 logos (320 x 118 dots) or 26 logos (256 x 64 dots) can be stored.

Before starting the following operation, set the initial setting #10-7 to 1.

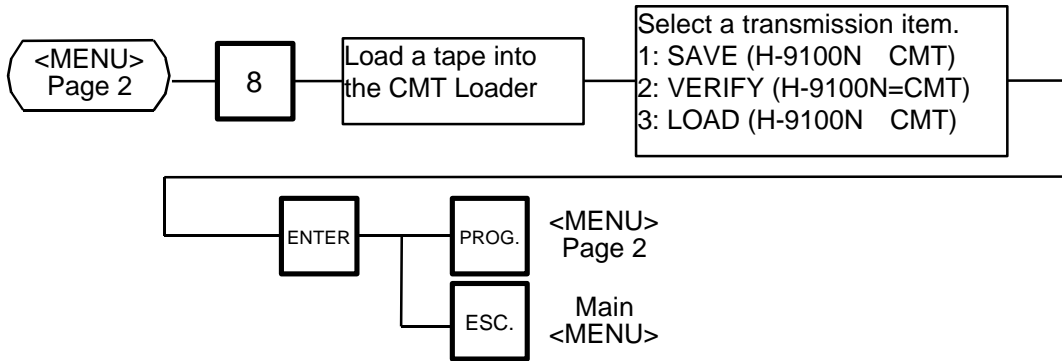

NOTE: Two sizes of logos are printed differently as follows:

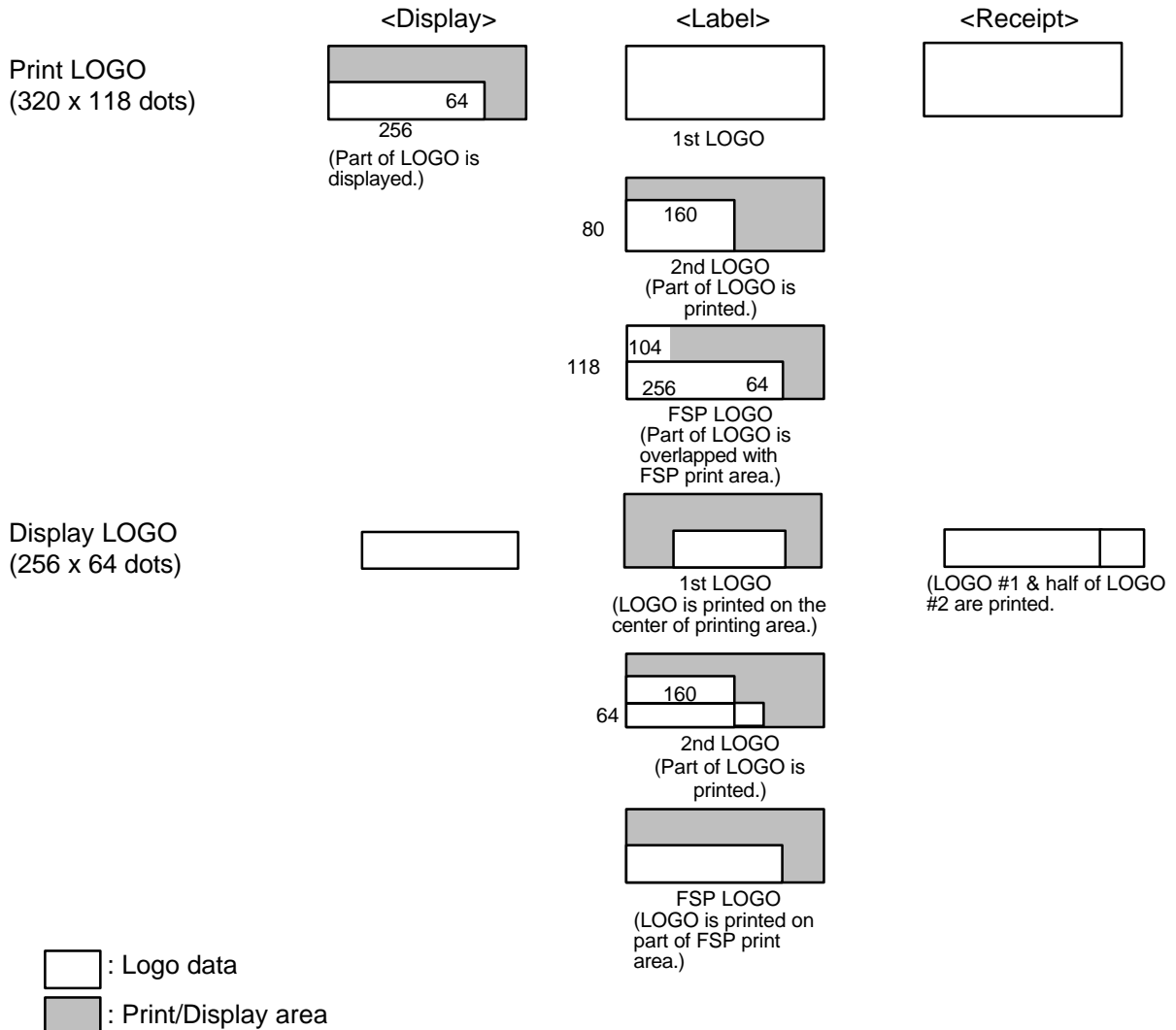

Table 6: Error message for data transmission

Error message	Cause	Error position	
		Header text	Data text
DATA ERROR	Timeout		
	Incorrect segment		
	Incorrect logo size		
	Incorrect number of logos		
	Incorrect logo number		
	Incorrect number of dots to be printed.		
	Parity error		
	Framing error		
	Overrun error		

10.19 IDIOM SETTING

Menu Page: 2

Item No.: 9

Up to 50 terms frequently appearing in ingredient messages can be preset using the following procedure. The idiom number must be set from 1 to 50 in order. One idiom can contain a maximum of 20 characters.

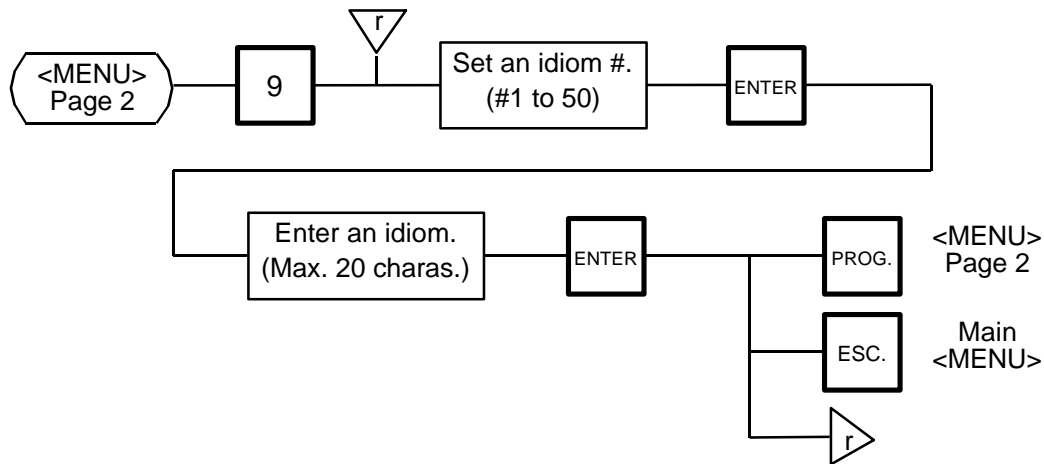

10.20 VENDOR SETTING

Menu Page: 3

Item No.: 0

Up to 40 vendors can be registered using the following procedure. The vendor number must be set from 0 to 39 in order. One vendor name can contain a maximum of 12 characters.

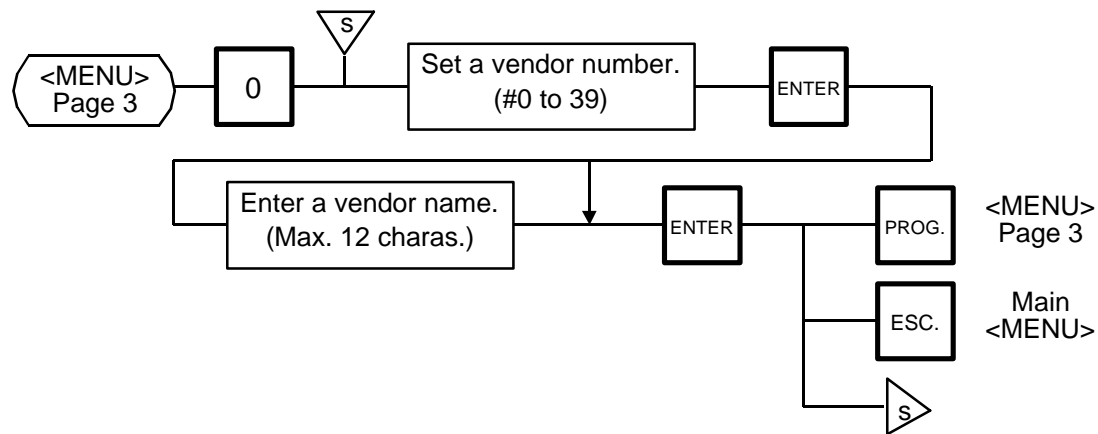

Deleting a vendor number

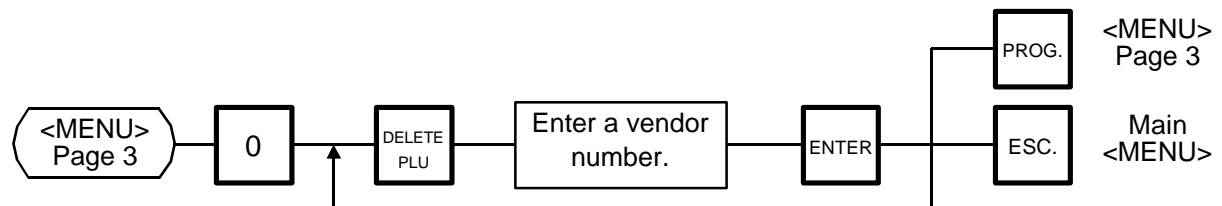

10.21 FREE FORMAT SETTING

Menu Page: 3

Item No.: 1

When using 57-mm wide labels, up to three print formats can be changed freely. Moreover, characters can be rotated and magnified, and print items are selectable.

Enter the coordinate of each print item's lower left corner using the lower left corner of a label as the origin. When a print item is located beyond the label width, an error will occur.

Key functions

: Moves downward (Data is stored.)

ENTER : Moves downward (Data is stored.)

: Moves upward (Data is stored.)

: Moves to the right

: Moves to the left

: Selects a setting

a. ROT (Rotation) : 0 → 90° → 180° → 270°

b. MAG (Magnification) :

- 0: normal
- 1: x 2 (width)
- 2: x 2 (height)
- 3: x 4 (width: x 2, height: x 2)

c. PRT (Print) : ON ↔ OFF

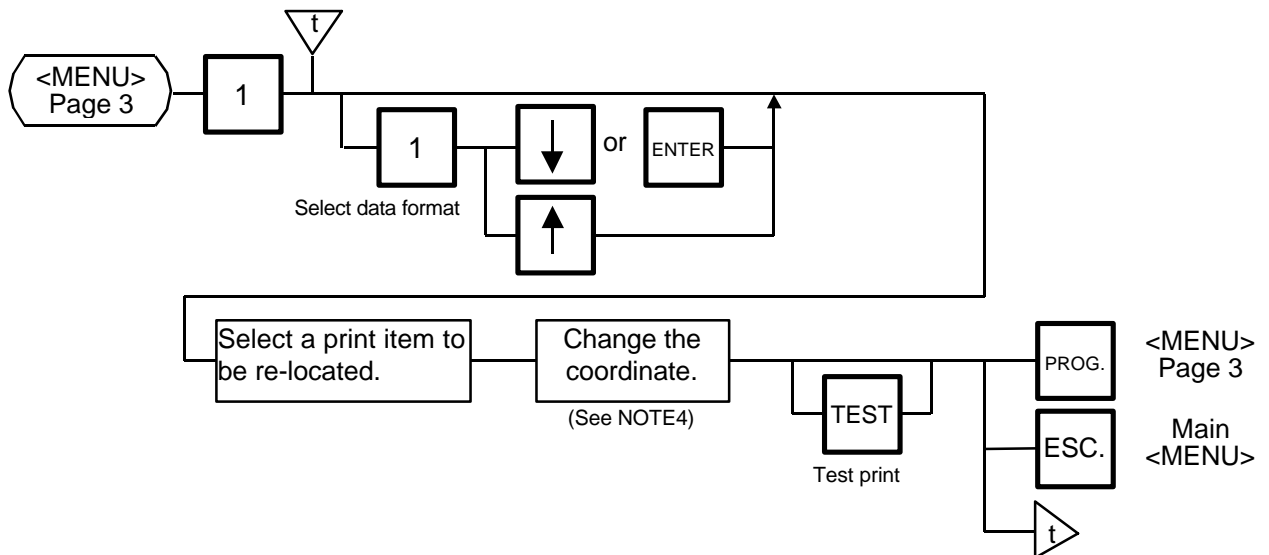

NOTES:

1. The following print items cannot be magnified.

LOGO (1)

Safe handling precautions

LOGO (2)

Barcode

LOGO for Frequent Shopper

Nutrition

FSP block

Ingredient

2. Base label format

According to Initial set #10-1, the base label format having the same width is selected. Therefore it is impossible to select format having a width of 57 mm when the width of 80 mm is selected in the initial set, and vice versa.

3. Data range

The valid range of each data is follows.

Free Format No.: 1 to 3 for 57-mm and 80-mm wide labels.

The free format No. corresponds with label format #41 to 43 and #91 to 93 for Batch print. Programmed free format data remains even though the label width is changed by the initial set. This means that the H-9100N has up to 6 formats.

Base label format No.: 57-mm wide: #10, 11, 13, 15, 16, 21, 23, 25, 26, 31, 33, 35, 36, 44
80-mm wide: #10, 11, 23, 44, 45, 46, 47

Label length (mm): 57-mm wide: 30 to 195
80-mm wide: 30 to 135

Label width (mm): 57 or 80 according to Initial set No. 10-1

Barcode height (mm): 0 to 30

X point (dot): 57-mm wide: 0 to 447
80-mm wide: 0 to 631

Y point (dot): 57-mm wide: 0 to 1560
80-mm wide: 0 to 1080

No. of ingredient lines: 0 to 38

No. of Ing. characters per line: 32 to 54 (default: 54)

4. Each print item should be printed in the following range.

		Type 1				Type 2				Note
		Normal		Rotation		Wide		Rotation		
		X	Y	X	Y	X	Y	X	Y	
1	Commodity name (4 lines)	384	108	108	384	576	108	108	576	
2	Commodity name (2 lines)	384	54	54	384	576	54	54	576	
3	Ingredient	384	*1	*1	384	594	*1	*1	594	*1: Ing. lines x 15
4	Packed ON	84	24	24	84	126	24	24	126	
5	Packed ON (title)	70	13	13	70	110	13	13	110	
6	Sell BY	84	24	24	84	126	24	24	126	
7	Sell BY (title)	70	13	13	70	110	13	13	110	
8	Weight	106	24	24	106	158	24	24	158	
9	Weight (title)	105	13	13	105	165	13	13	165	
10	Unit price	140	24	24	140	208	24	24	208	
11	Unit price (title)	105	13	13	105	165	13	13	165	
12	Price	138	38	38	138	206	38	38	206	
13	Price (title)	105	13	13	105	165	13	13	165	
14	Barcode	212	*2	----	----	----	----	----	----	*2: Height/0.125
15	Mark (M/R/T)	12	24	24	12	18	24	24	18	
16	Tare	100	24	24	100	148	24	24	148	
17	Tare (title)	35	13	13	35	55	13	13	55	
18	SP-INFO/NET WT	384	48	48	384	576	54	54	576	
19	Relish	84	24	24	84	126	24	24	126	
20	Relish (title)	228	14	14	228	342	16	16	342	
21	LOGO	320	118	118	320	160	80	80	160	
22	LOGO (2)	320	118	118	320	160	80	80	160	
23	Safe handling	384	194	194	384	592	120	120	592	
24	Address	384	32	32	384	576	36	36	576	
25	(F) Price	138	38	38	138	206	38	38	206	
26	(F) Price (title)	105	13	13	105	165	13	13	165	
27	(F) Unit price	140	24	24	140	208	24	24	208	
28	(F) Unit price (title)	105	13	13	105	165	13	13	165	
29	(F) Weight	106	24	24	106	158	24	24	158	
30	(F) Weight (title)	105	13	13	105	165	13	13	165	
31	(F) Saving Price	138	38	38	138	206	38	38	206	
32	(F) Saving Price (title)	105	13	13	105	165	13	13	165	
33	(F) LOGO	320	118	118	320	160	80	80	160	
34	Nutrition	320	670	----	----	----	----	----	----	
35	FSP block	400	194	194	400	600	194	194	600	

- (1) An error occurs unless the following conditions are met.
 The X value (X point value plus print area's X point value) must not exceed 448 dots on the 57-mm wide labels, and 632 dots on the 80-mm wide labels.
 The Y value (Y point value plus print area's Y point value) must not exceed 1560 dots (195mm) on the 57-mm wide labels, and 1080 dots (135mm) on the 80-mm wide labels.
- (2) The area size is magnified (x2) for items to be magnified.
- (3) Safe handling instructions
 Normal type: 384 (W) x 194 (H) dots (same as the ingredients of 13 lines)

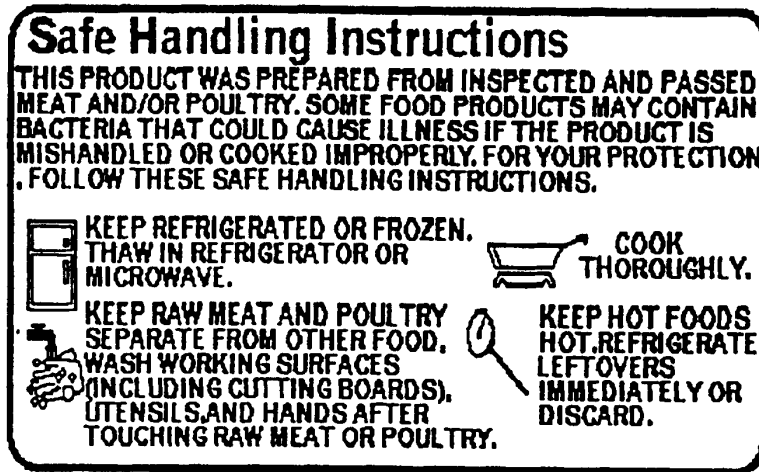

Wide type: 592 (W) x 120 (H) dots (same as the ingredients of 8 lines)

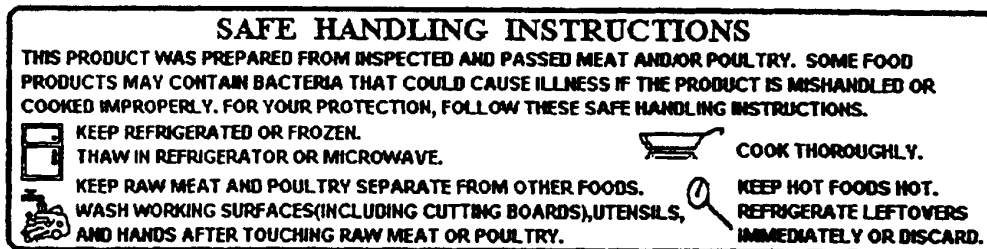

- (4) FSP block
 FSP print format can be programmed easily with FSP block. All of FSP print items are moved together as one block since FSP block is set "on" status to PRT condition. In this case each of FSP print items cannot be moved by itself until status is "off".

(5) Nutrition facts

Nutrition facts for the 80-mm wide "All in one" label are as follows.

Nutrition Facts	C/G size	bold
Serving Size	14 x 38	bold
Serving Per Container	10 x 24	a
Amount Per serving	10 x 24	bold
Calories	10 x 24	bold
Calories from Fat	10 x 24	
% Daily Value *	10 x 24	bold
Total Fat g	10 x 24	bold
Saturated Fat g	10 x 24	
Cholesterol mg	10 x 24	bold
Sodium mg	10 x 24	bold
Total Carbohydrate g	10 x 24	bold
Dietary Fiber g	10 x 24	
Sugars g	10 x 24	
Protein g	10 x 24	bold
Vitamin A % Vitamin C %	10 x 24	
Calcium % Iron %	10 x 24	
* Percent Daily Values are based on a 2,000 calorie diet.	6 x 16	

← 320 dots →

Total height 670 dots

5. The following items cannot be rotated.

Barcode

Nutrition Facts

*LOGO, Safe handling and FSP block are performed only 90° rotation.

6. When pressing the **TEST** key, the printer issues a test label.

It is impossible to issue the test label with batch printing.

7. Rotated data will be printed so that the lower left corner is positioned at the designated coordinate.

(1) 0°

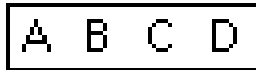

(2) 90°

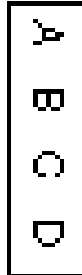

(3) 180°



(4) 270°

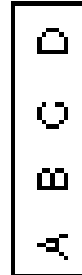

The points indicated by the arrows are the designated coordinates.

8. X/Y values

X/Y values on the label are indicated in the following figures.

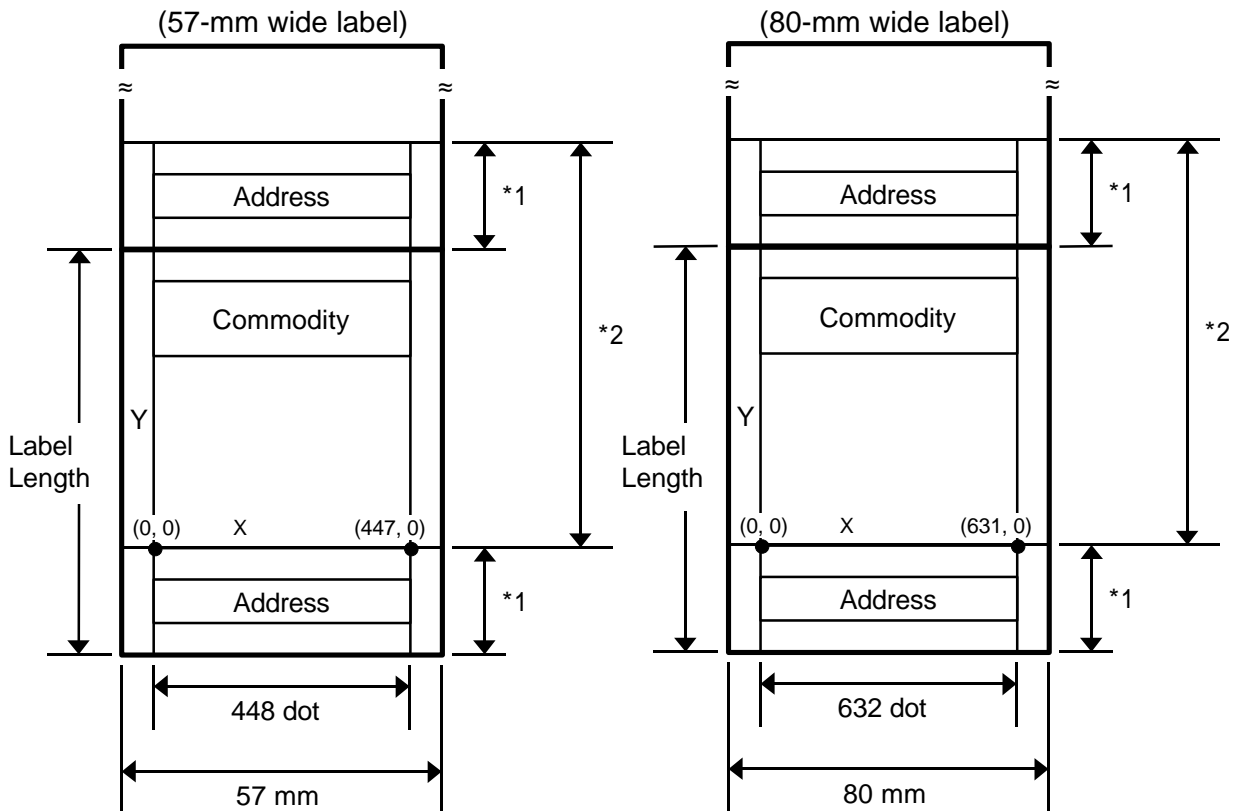

*1: Pre-feed area

The address is printed.

*2: Free format arrangement area

9. Dot size

The dot size of the thermal head is 0.125mm square.

11. PROGRAMMED DATA VERIFICATION REPORTS

The programmed data can be printed on journal paper. Before issuing these reports, load the journal paper. The programmed data verification reports cannot be issued with any label. The keys to be used in the following procedures are those on the numeric key pad, which is right side of keyboard in the figure on page 5-3, but not on the programming keyboard.

How to access REPORT menu

Press the **ESC.** key to access th following display. Enter "5", and the scale will enter the REPORT menu. If the REPORT menu is protected, enter "5" and a password. (Refer to section 13)

<Menu>	
0. PROG.	5. REPORT
1. REG	6. RESET
2. MARK DOWN	7.
3. REWRAP	8.
4. SECURITY	9.

Menu : REPORT

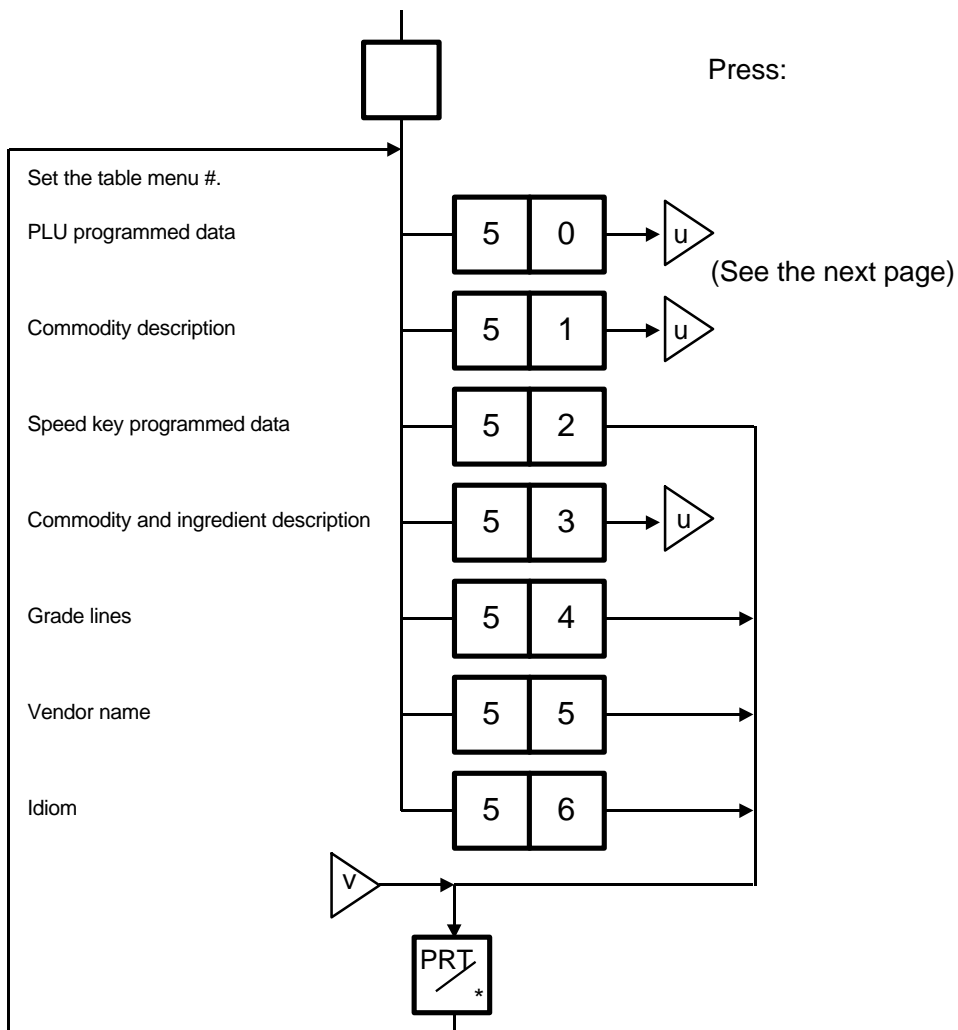
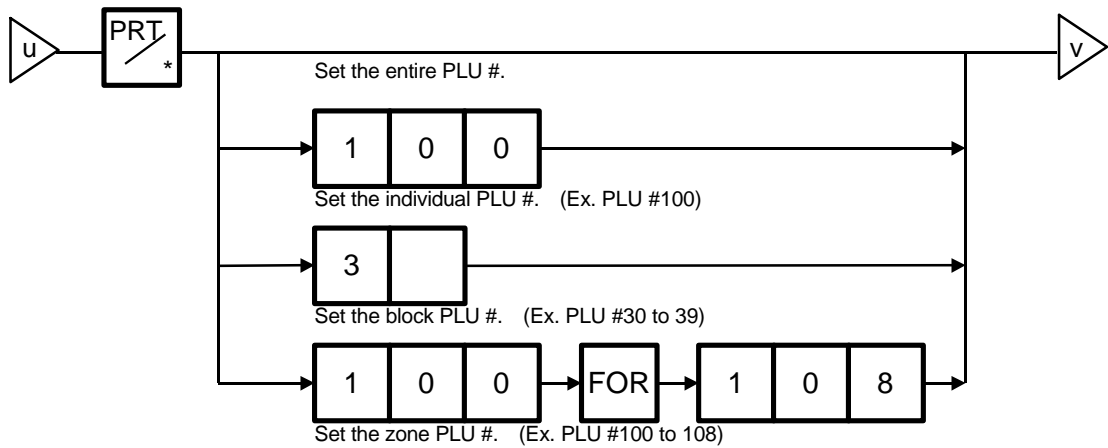

Table 7

Menu #	Report Name	Contents
50	PLU programmed data report	All the preset PLU data are listed in the PLU # order (from small to large #).
51	Commodity description report	All the preset commodity names are listed in the PLU # order (from small to large #).
52	Speed key programmed data report	The PLU # and the commodity name preset on each speed key is listed.
53	Commodity and ingredient description report	All the presets commodity names and ingredient messages are listed in the PLU # order (from small to large #).
54	Grade line report	All the preset grade line contents are listed.
55	Vendor name report	All preset vendor names are listed.
56	Idiom report	All preset idioms are listed.

Set the data range of each programmed data verification report



12. PASSWORD SECURITY

You can protect all menus (except REG. menu) and set two step passwords for access to protected menus.

12.1 SETTING PASSWORD AND PROTECT MENU

<Menu>	
0. PROG.	5. REPORT
1. REG.	6. RESET
2. MARK DOWN	7.
3. REWRAP	8.
4. SECURITY	9.

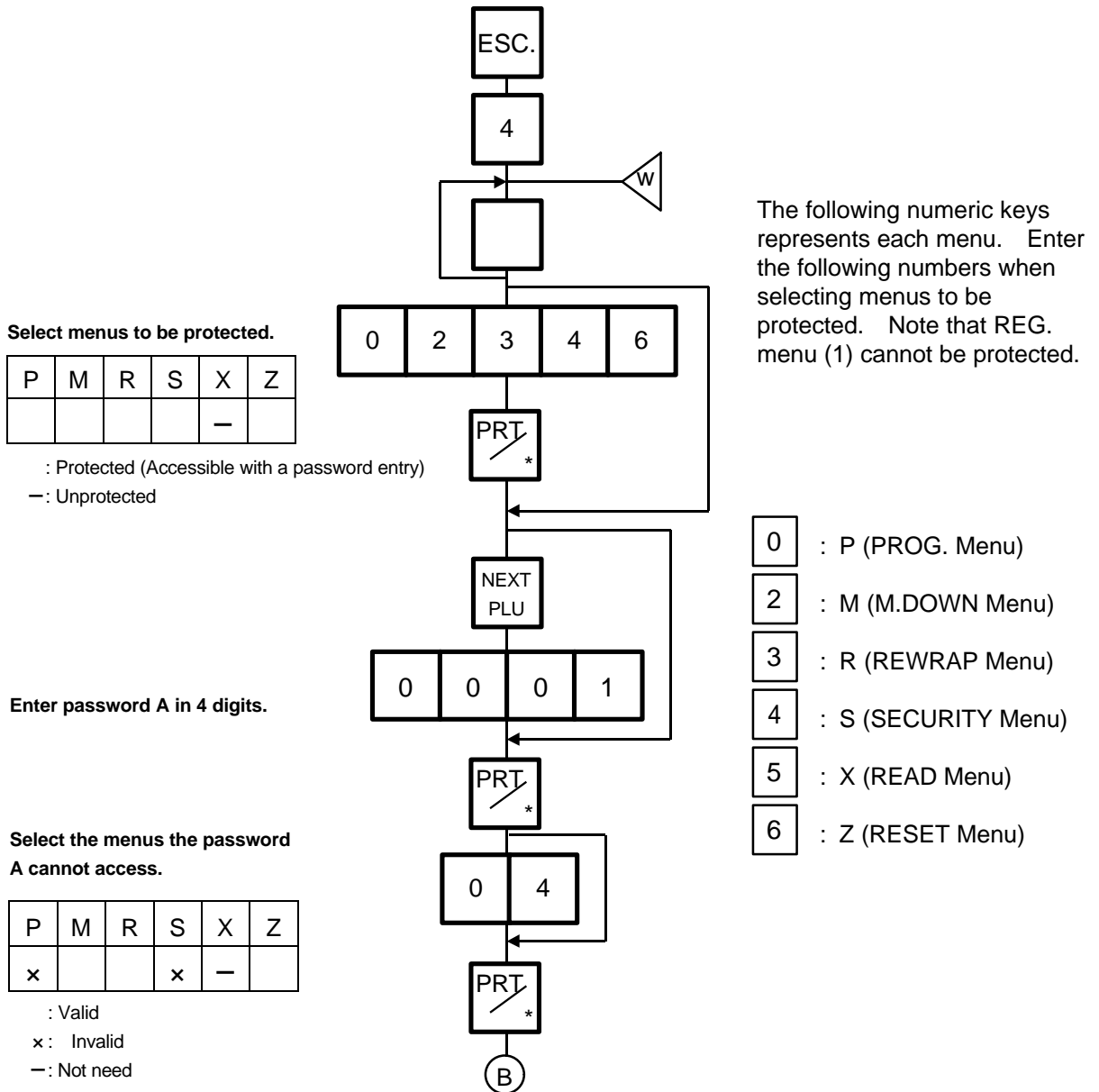

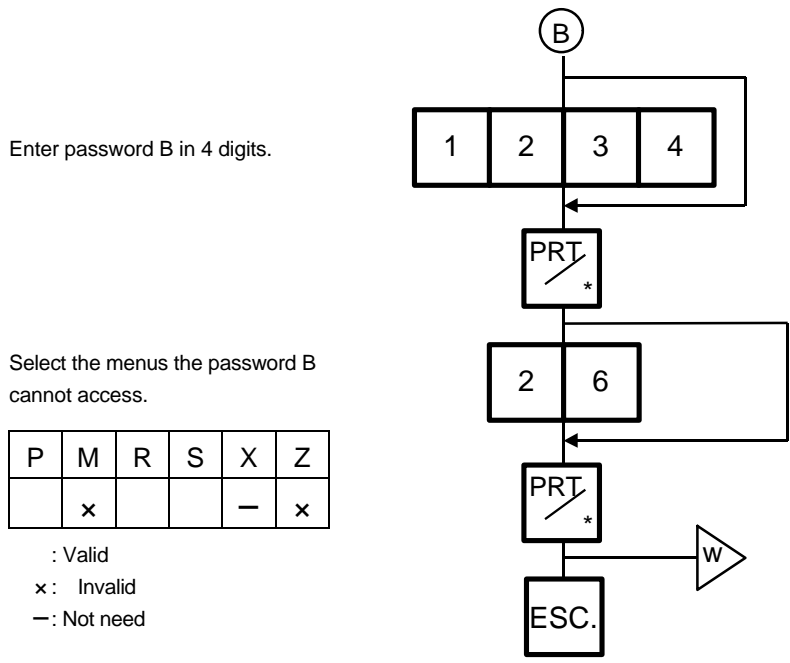

NOTES:

1. Select validity of the password by pressing the key
2. When the same password is entered for password A and B, password A has priority over the password B.
3. Be careful if you exclude the same menu from the accessible menus with both password A and B, you will not be able to access the menu.

12.2 CALLING MENU BY ENTERING PASSWORD

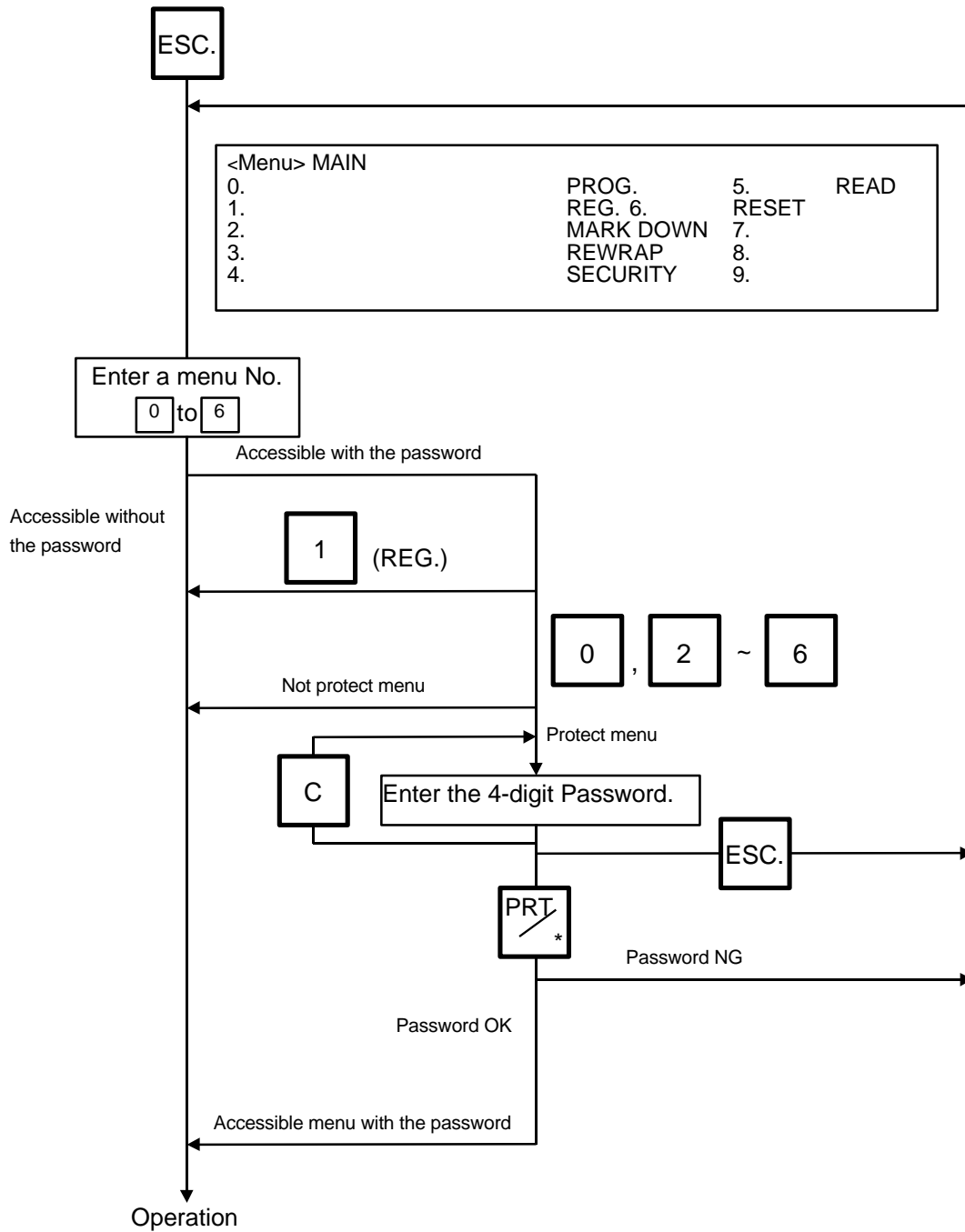

NOTE: When the password is unknown, enter "HELP" instead, and you can access only security menu.

13. OPERATING PROCEDURES

NOTES BEFORE STARTING OPERATION

- (1) Turn the power ON.
- (2) A sixteen-second scanning will be performed after pressing the **POWER** key.
- (3) Should a power failure occur during the operation, remove the commodity from the platter and insert the power plug into an AC outlet again when power is restored.
- (4) If the scale is used with an unrated power source, inaccurate scaling or other errors may occur.
- (5) If the zero point has shifted while scaling, and no tare is displayed, adjust the zero point by pressing the **ZERO** key.
- (6) Check the date of the scale before the daily operation.
- (7) Make a test print before operation every day.
Press the **TEST** key, and the test label is issued.

How to access REG., M.DOWN, or REWRAP menu

The following display is displayed on the REG. menu display. When this display is shown after pressing the **POWER** key, you can start the REG. operation right away.

<REG.> MENU WEIGH		
ENTER THE PLU#		
lb	UNIT/\$	TOTAL \$
0.000	P	000000

To access a menu from other menus, press the **ESC.** key to show the Main menu and enter the menu No. When the MARK DOWN and REWRAP menus are protected, enter the menu No. and then the password.

<Menu> MAIN	
0. PROG.	5. READ
1. REG.	6. RESET
2. MARK DOWN	7.
3. REWRAP	8.
4. SECURITY	9.

NOTE: If a label nothing is printed on is issued after a printed label in batch mode, refer to Section 10.11 and press the **SET NEXT** key.

13.1 WEIGHING OPERATION

Menu: REG., M.DOWN, or REWRAP
 Mode: WEIGH

The weigh mode is used to weigh a commodity and to issue labels. The label contains data such as a weight, unit price (price per weight) and total price (calculated as a result of the weighing operation). The following is a basic operation seen at the sales floor of a store or at a back room where different kinds and weights of commodities are repacked. Pressing the **VOID** key subtracts the last entry from the memory.

Example) When PLU #100 and an unit price of \$8.00 are set in the speed key #12.

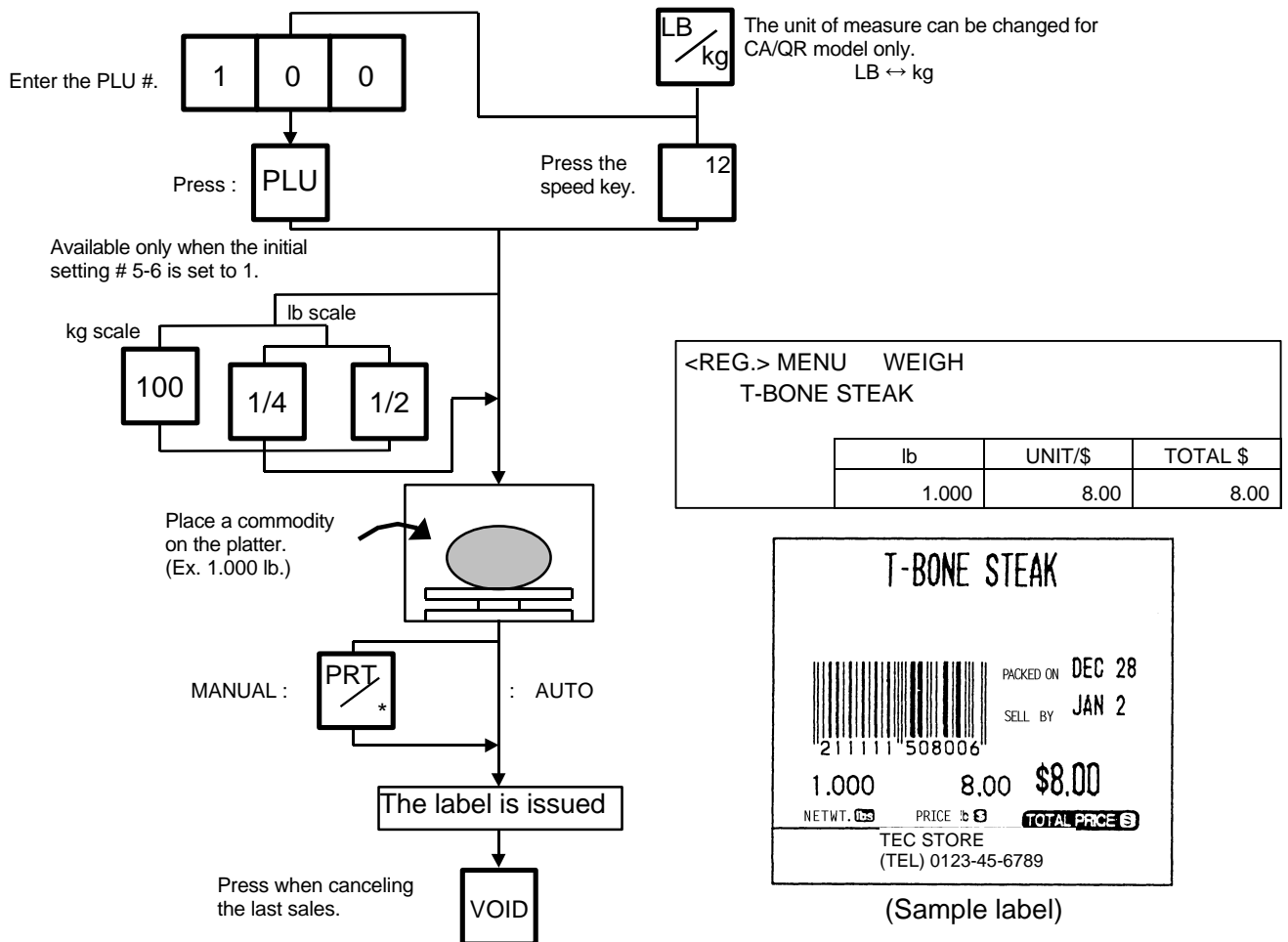

NOTES:

- Pressing the speed key to which no PLU data has been assigned will result in an error. In this case, press the **C** key, then press the speed key to which PLU data has been assigned.
 - To change between AUTO and MANUAL, follow the procedure provided in section 13.9.
 - If a unit price exceeding 4 digits is obtained by multiplying by 2 or 4 (when pressing the **1/2 lb** key or **1/4 lb** key), the unit price will be 0.
 - 100 g** key is available only when the scale is a kg scale or operated on kg base.
 - When the **1/2 lb**, **1/4 lb** or **100 g** key is pressed, the unit price does change on the display.
 - When the "compulsory tare" is selected, a tare must be subtracted in a weighing operation, otherwise an error message "TARE REQUIRED" will be displayed when the following operation has been done:
 Manual mode: Pressing the **PRT/*** key.
 Auto mode: Placing a commodity on the platter.
 Floating vendor mode: Pressing the **Vendor** key.
- When a "TARE REQUIRED" is displayed, refer to Section 13.6 to follow the proper weighing procedure.

13.2 FIX PRICE OPERATION (FOR US TYPE ONLY)

Menu: REG., M.DOWN, or REWRAP

Mode: FIX

The FIX mode (Fix Price Mode) is used to issue a label for a commodity of a fixed price PLU (i.e. the price determined by the store), the weight which may vary from commodity to commodity. In this mode, the Unit Price of the commodity looked up from the PLU file will be printed as the Total Price regardless of its actual weight, and the weight is also printed on the label.

Example) In case of PLU #636 with fixed price \$3.80 which is assigned to speed key #7.

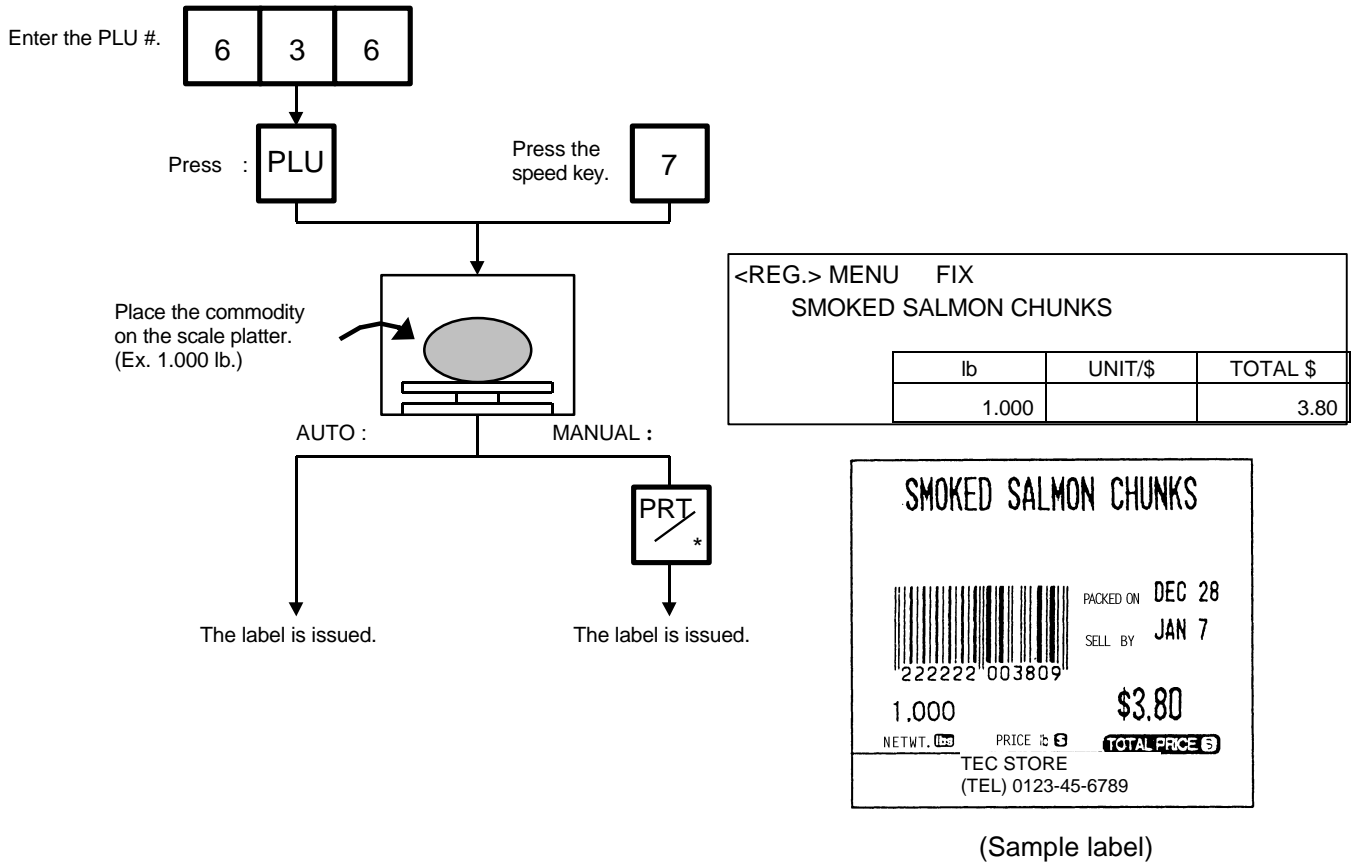

13.3 BY COUNT OPERATION

Menu: REG., M.DOWN, or REWRAP
 Mode: BY-COUNT

The BY-COUNT mode is used to issue the label of commodities in a package (or may not be packed). The whole package quantity (or a certain quantity) and the whole package price (or the price per the quantity) are usually preset. Thus, it is not necessary to weigh the commodities by the scale in such cases.

Example) In case of sell 10 DONUTS at the price of \$1.50 per 4 DONUTS. (When a price of \$1.50/4 DONUTS is set for PLU #33.)

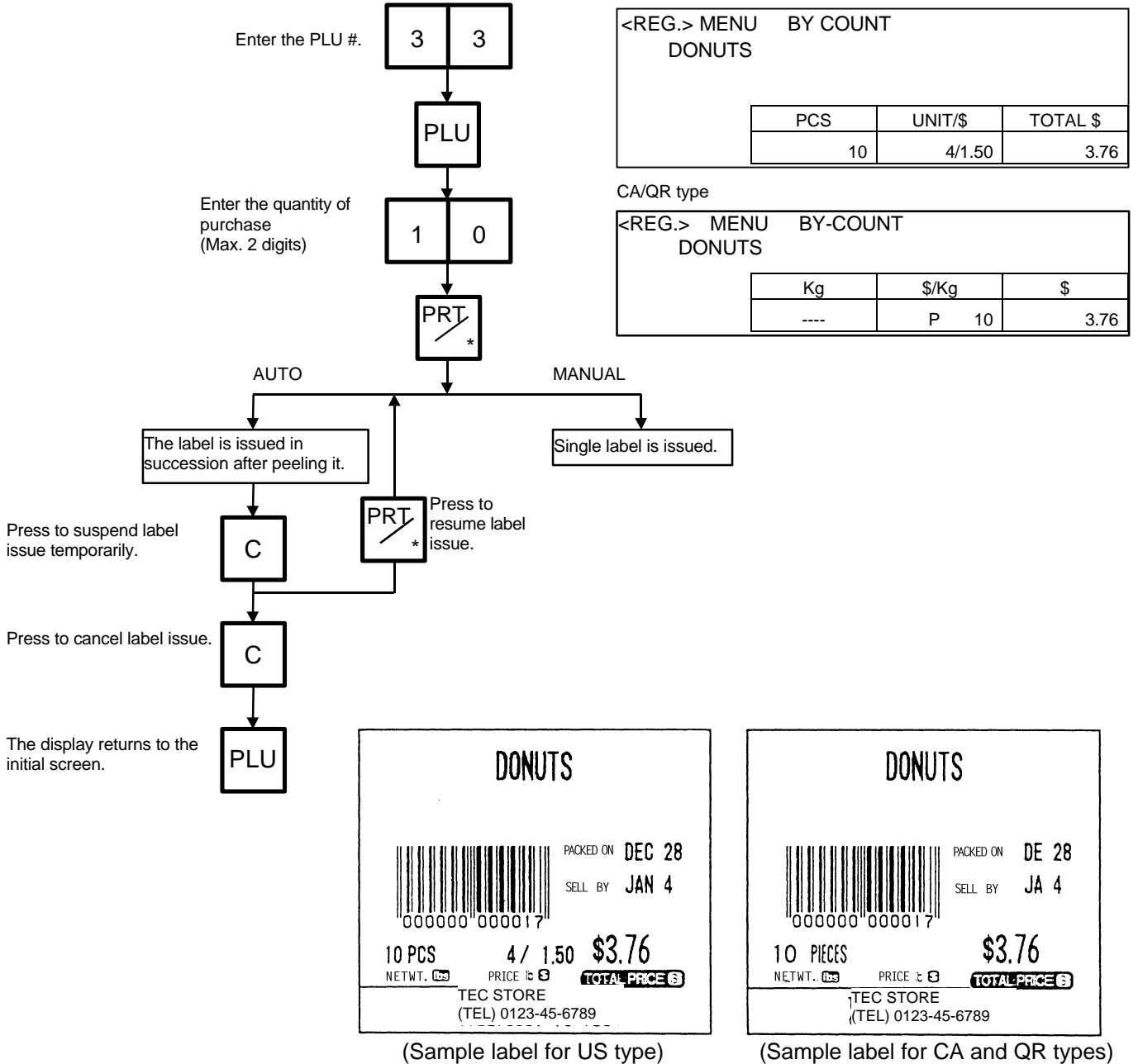

Example) An open price item can be sold as below:
 1 piece at 15 dollars
 15 pieces at 10 dollars
 15 pieces sold at 0.5 dollars per 10 pieces

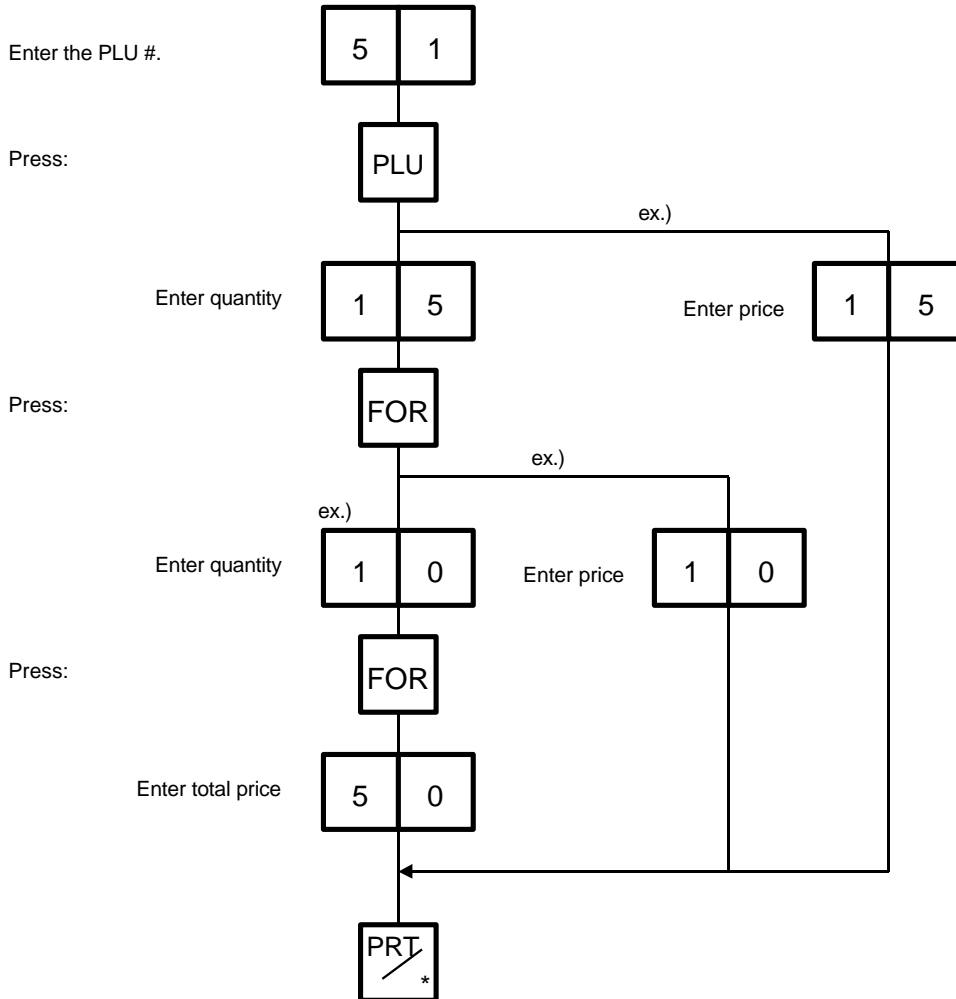

13.4 PRINT COUNT OPERATION

Menu: REG., M.DOWN, or REWRAP
 Mode: WEIGH, FIX or BY-COUNT

With this procedure, a specified number of the same labels can be issued.

Example A) When operating in Weigh mode.

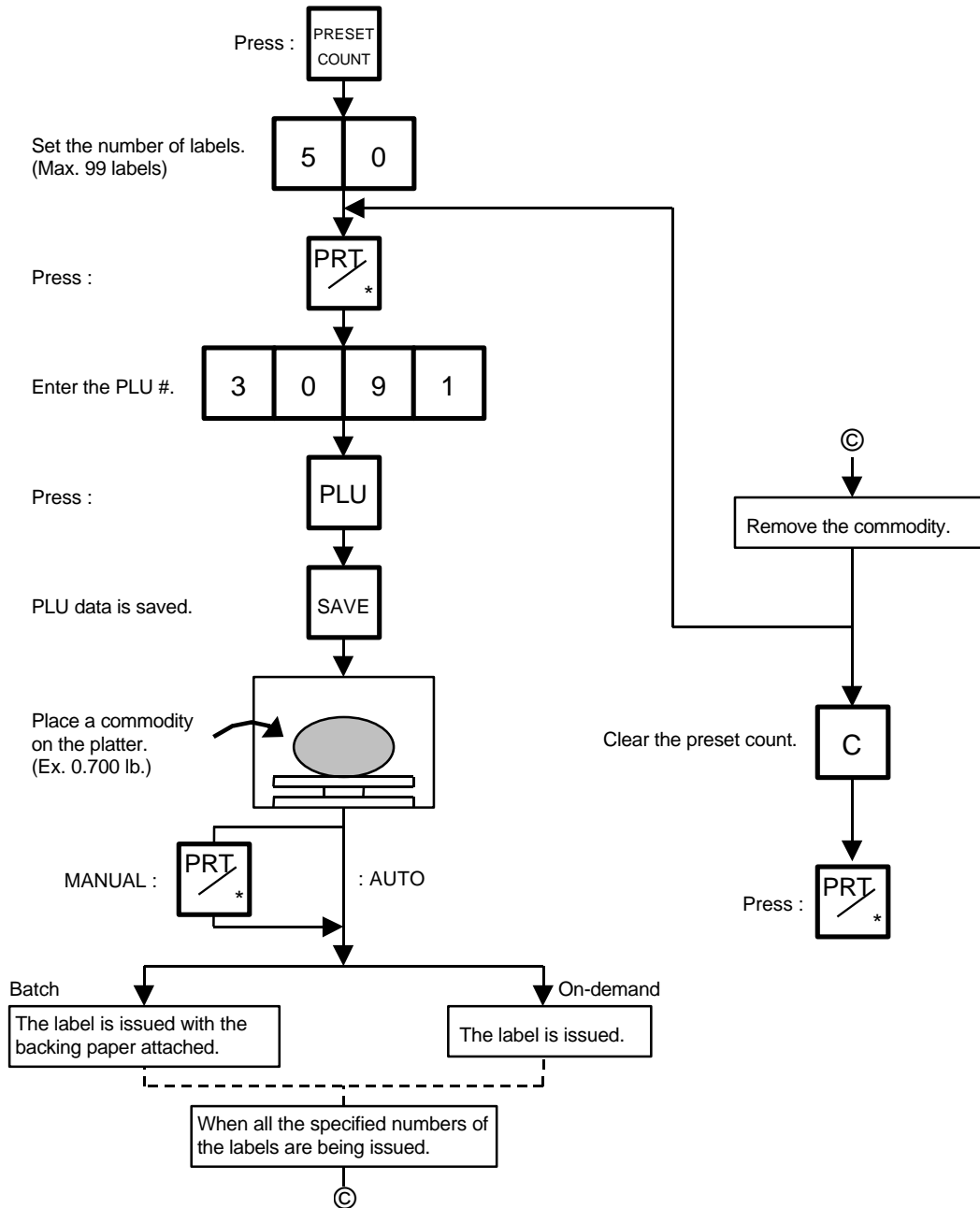

NOTES:

1. A batch issue means to print labels continuously with the backing paper attached. On-demand issue means to print labels one by one.
2. To check the remaining number, press the **PLU** and the **PRESET COUNT** key.

Example B) When operating in Fix or By Count mode.

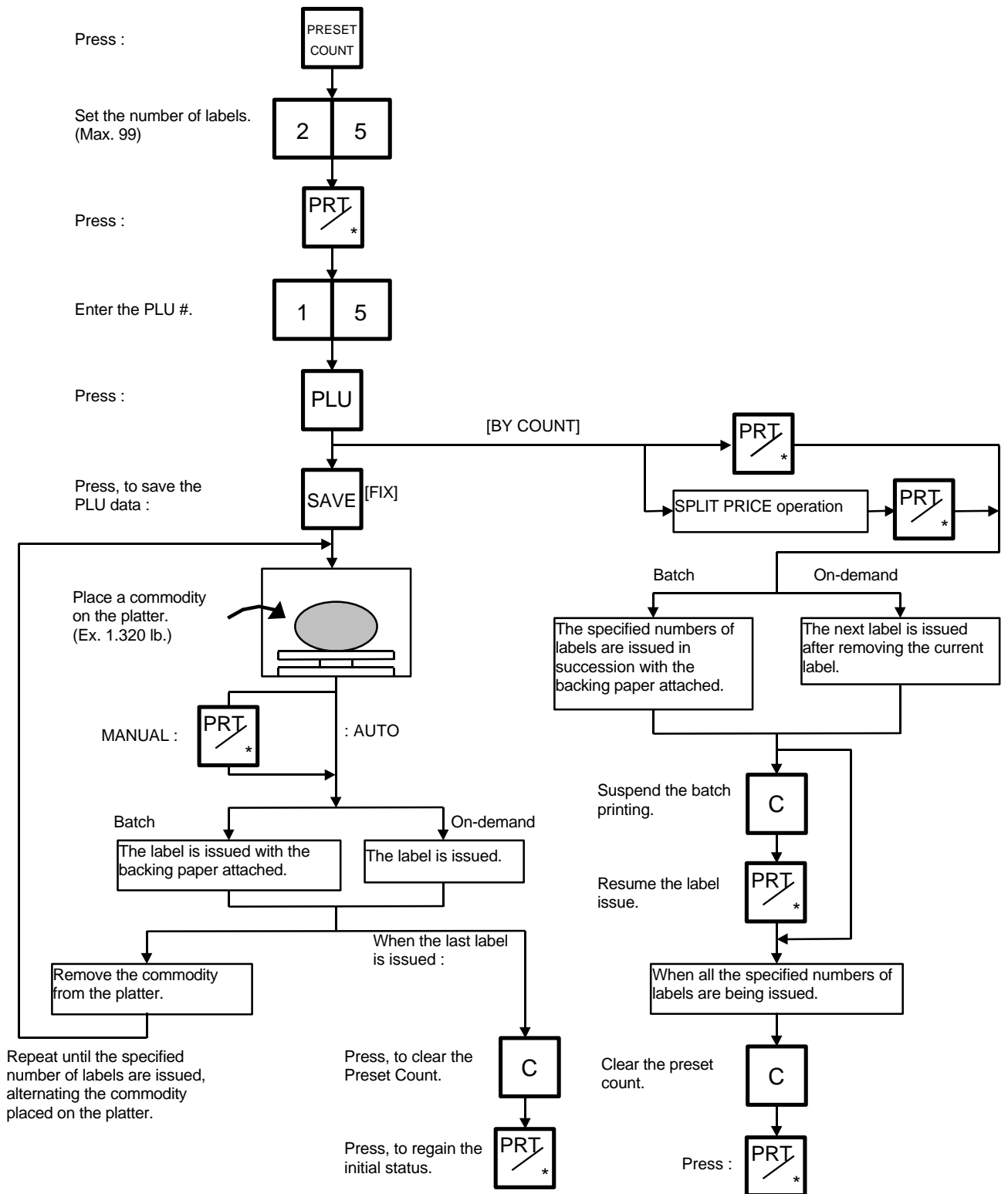

Example C) When issuing only the nutrition information label. Note that nutrition information can be printed only on several types of label. Refer to Page 10-19.

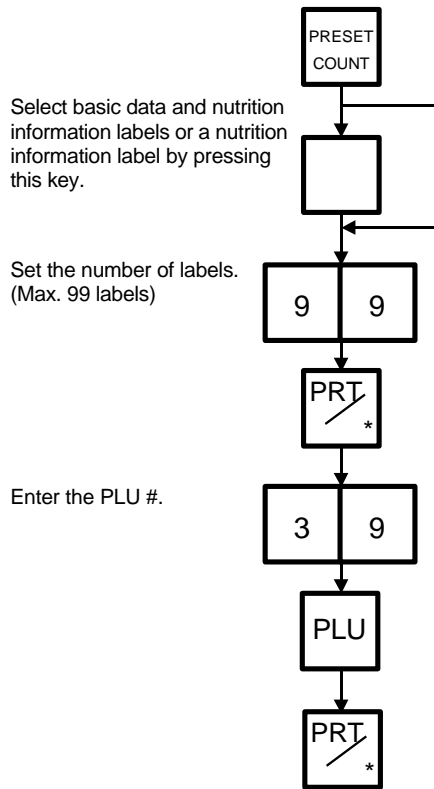

Table 8

The nutrition information label is issued in the following methods.

Issue mode	Manual issue				Auto issue			
	On-demand		Batch		On-demand		Batch	
	Pre=0	Pre>=1	Pre=0	Pre>=1	Pre=0	Pre>=1	Pre=0	Pre>=1
Weigh	1	1	1	1	1	1	1	1
Fix (Weight/price)	1	1	1	1	1	1	1	1
Fix (Net weight)	1	1	1	1	1	1	1	2
By count	1	1	1	1	1	1	1	2

NOTE:

Pre : Preset count

1 : Issue method

After a basic data label is issued, a nutrition information label will be issued.

2 : Issue method

After the specified number of basic data labels are continuously issued, the same number of nutrition information labels will be issued. The number of labels can be specified with the preset count setting.

13.5 ISSUING LABELS WITH NET WEIGHT STATEMENT (FOR US TYPE ONLY)

Menu: REG., M.DOWN, or REWRAP
 Mode: FIX

When the initial settings #1-7 and #1-8 are set to 1, a Net Weight Statement is printed on the label.
 A unit price and a tare registered in each PLU are printed as a price and a net weight.

Example) The preset price is \$2.10 and the preset Net Weight is 12 oz. The store knows that the actual Net Weight of this commodity is 19 oz. and decides to sell it at \$2.00.

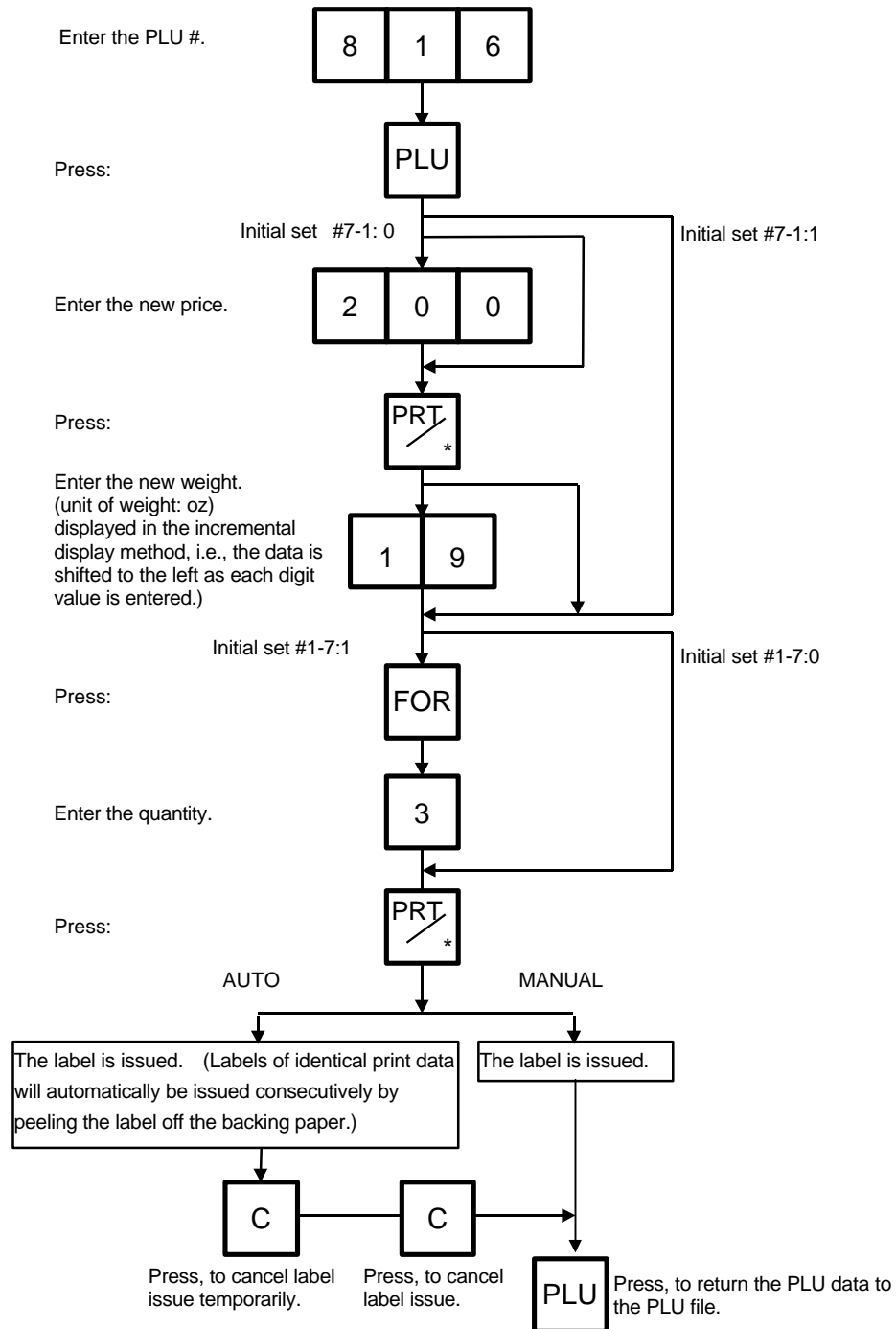

13.6 TARE/SAVE FUNCTION PROCEDURES

Menu: REG., M.DOWN, or REWRAP

Mode: WEIGH or FIX (Tare % function is available in WEIGH mode only.)

There are two kinds of tare subtraction procedures, one is "Direct tare", the other is "Preset tare". The **SAVE** key is used to save the tare, unit price, and PLU data after taking a commodity from the platter.

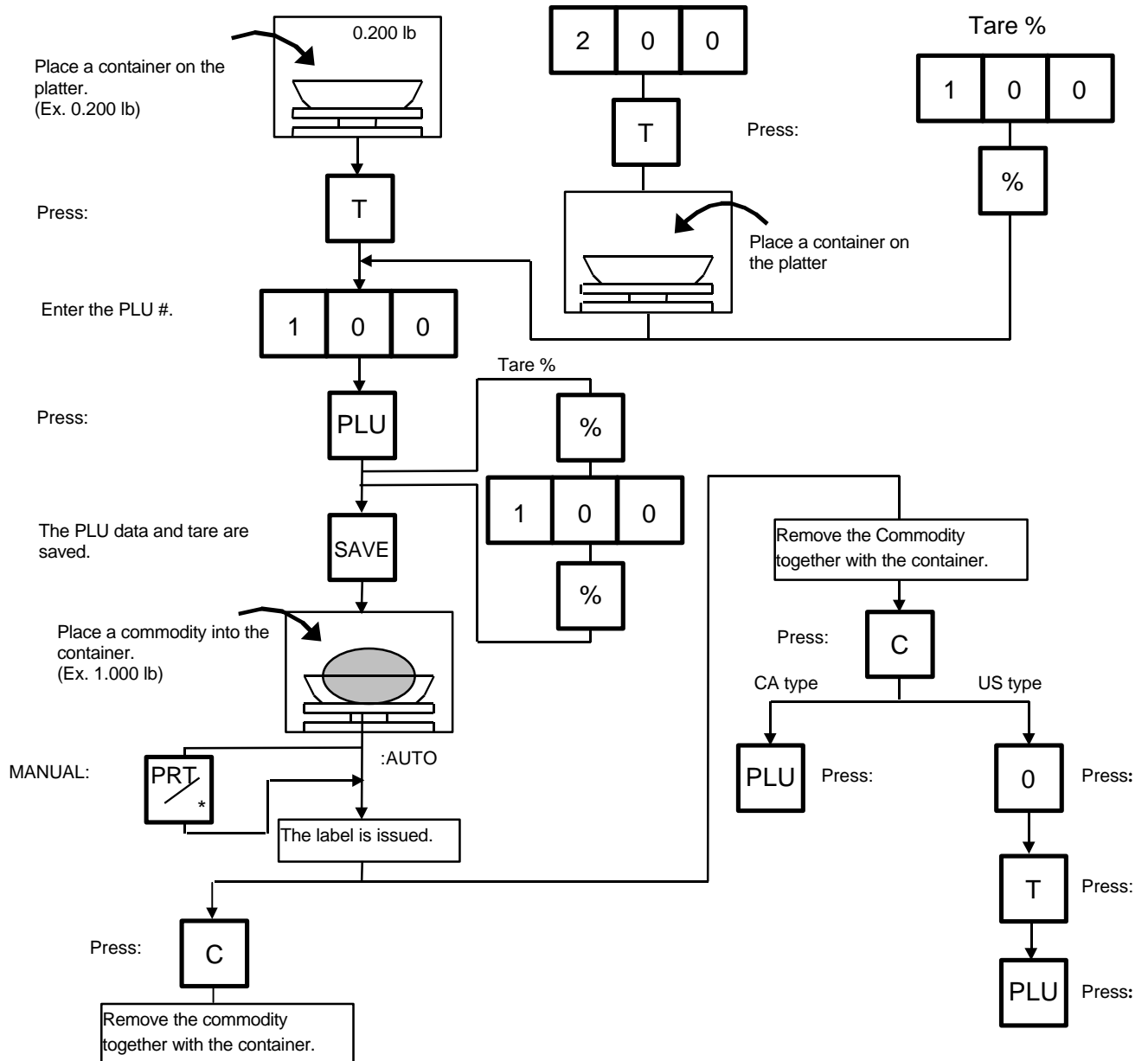

- NOTES:**
- Tare subtraction is available up to 4.00 lb. for the US type, and up to 2.000kg (4.00lb) for the CA type. When tare subtraction is in operation, however, the scalable range for net weight becomes less by the amount of the tare. (**Net weight=Gross weight-Tare**)
 - Preset tare must be a multiple of 5 g for CA type (Kg scale) and a multiple of 0.01 lb for US/CA type (Lb scale).
 - The tare % function is available when the Initial Setting #28-4 is set to 1. The speed key #108 will function as the % key (Refer to page 5-3). Set a tare % within the range from 0.0 to 99.9.
 - When a commodity is placed on the platter and the calculated tare exceeds the maximum, a "TARE WEIGH OVER" error will occur.

13.7 CALLING AND PRINTING GRADE LINES

Menu: REG., M.DOWN, or REWRAP

Mode: WEIGH or FIX, or BY COUNT

A grade line is a short message added to a commodity name.

A grade line can be selected from maximum of 49 programmed grade lines and printed on the label.

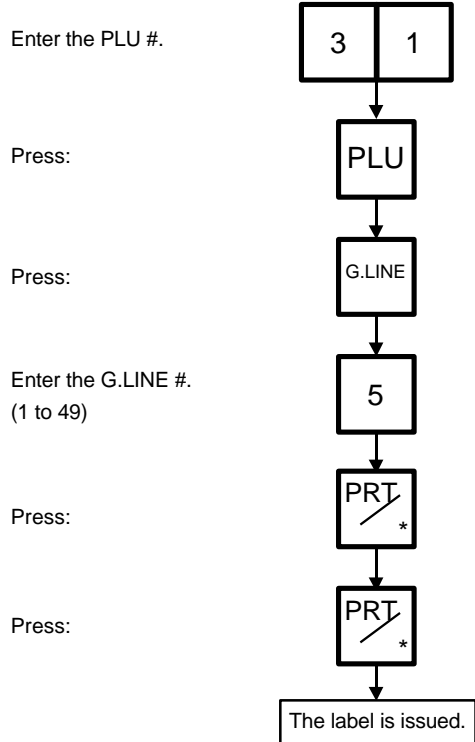

<REG.> MENU BY-COUNT			
DONUTS		Commodity Name	
PREMIUNS OFFERED		Grade Line	
	PCS	UNIT/\$	TOTAL \$
	10	4/1.50	3.76

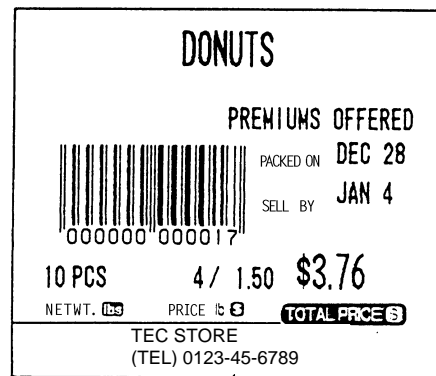

(Sample label)

13.8 CALLING AND PRINTING LOGOS

Menu: REG., M.DOWN, or REWRAP

Mode: WEIGH, FIX, or BY COUNT

When the initial set #10-7 is set to "1" or "2", a logo containing a picture, a mark, a POP message, etc., can be printed on the ingredient label having 12 lines or more.

Logo data is created on the PC and stored into the memory through the CMT/PL-3 interface.

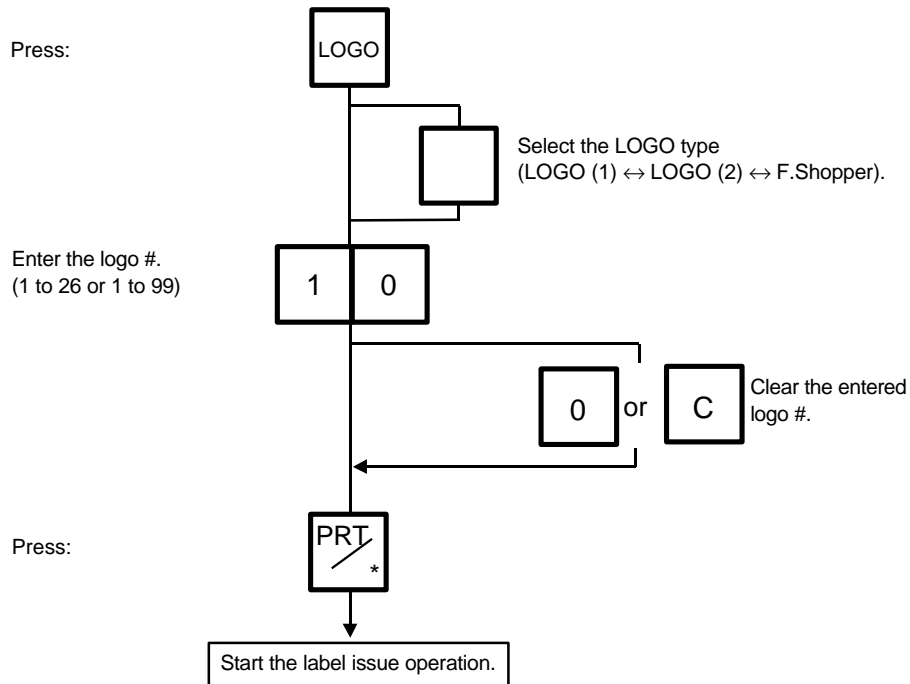

NOTES:

1. The logo # will be effective until it is changed or deleted.
(Logo # is still effective after turning the power off and/or changing mode.)
2. Pressing the **PRT/*** key returns the display to the initial display of weighing mode.
This clears the unit price and tare data.
3. LOGOs will not be printed together with a safe handling instruction on a label.
4. LOGOs will be printed in the center of a label.
5. LOGO # "1 to 26" or "1 to 99" is selectable with the initial setting #10-7.

13.9 SELECTING PRINT ITEM

Menu: REG, M.DOWN, or REWRAP

Mode: WEIGH, FIX, or BY COUNT

Press:

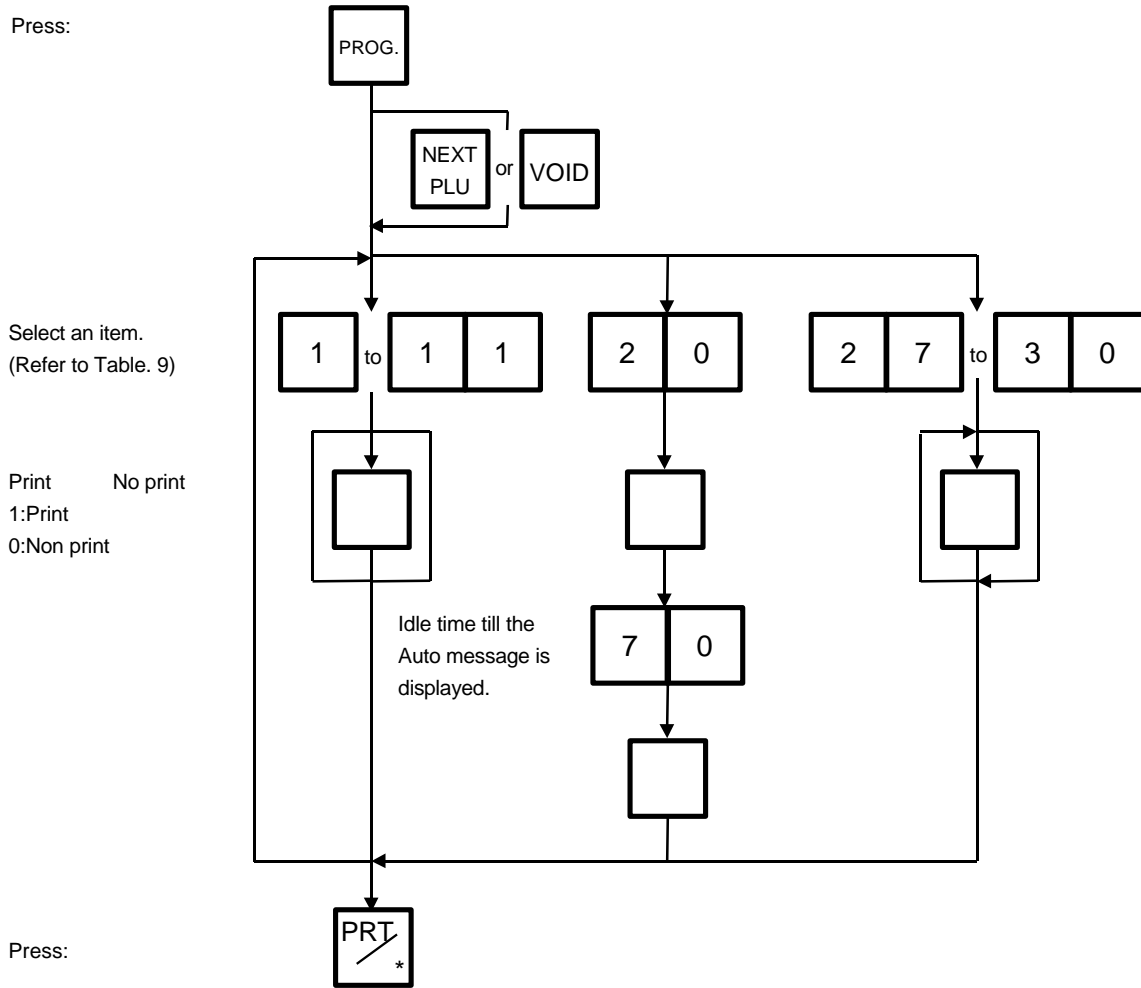

Table 9

Entry	Item	Print/Non Print	Entry	Item	Print/Non Print
1	Packed on date	Print/Non Print	9	Piece count	Print/Non Print
2	Sell by date	Print/Non Print	10	Cooked by date	Print/Non Print
3	Commodity name	Print/Non Print	11	SP/Info./Net Wt.	Print/Non Print
4	Weight	Print/Non Print	20	Auto message timer	0 ~ 99 sec.
5	Unit price	Print/Non Print	27	Media selection	Label/Receipt
6	Total price	Print/Non Print	28	Print format	Format No. Selection
7	Barcode	Print/Non Print	29	Mode (2)	Weight/Fix/By count
8	Ingredient	Print/Non Print	30	Mode (1)	Auto/Manual

NOTES:

1. A store code can be printed in place of a 'packed on date' and 'sell by date' by changing the initial settings #6-5 and #6-6.
To print a store code, select 'packed on date' or 'sell by date' as a print item using the above procedure
Additionally the print of "packed on time" with alphabetical code can be selected with Initial setting #6-6.
2. Setting data will not be changed by turning the power off, changing the mode or calling a PLU.
3. The 0 key has no function.
4. Pressing the C key allows you to return to the step of selecting the 'packed on date'.
5. The range of idle time=0 to 99 seconds. A setting ' 0 ' prohibits display of an auto message.
6. Item 29 is operable only when the initial setting #1-5 is set to '0'.
7. Be sure to press the FEED key after the PRT/* key when changing the label format.

13.10 DATE CHANGE

Menu: REG., M.DOWN, or REWRAP
Mode: WEIGH, FIX, or BY COUNT

The date can be changed temporarily.

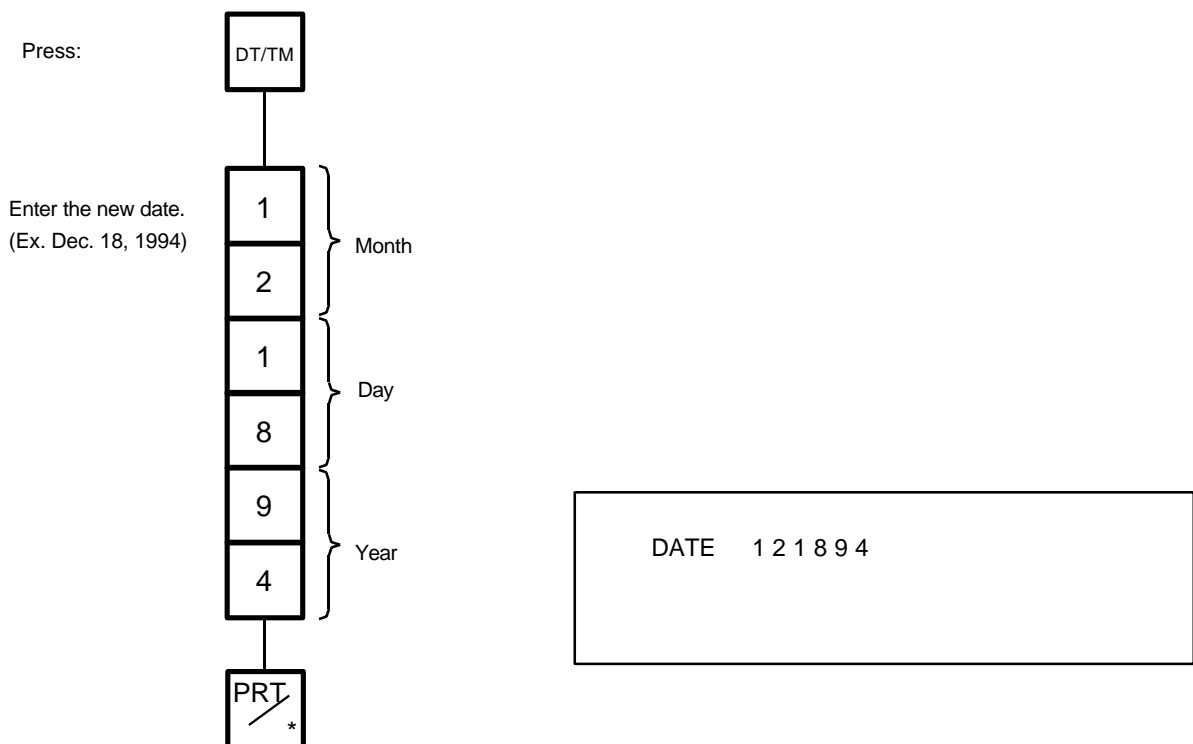

NOTE: The scale will check the details of the date input. An invalid date will result in an error.

13.11 BATCH PRINT MODE (with 30 Items Run Assignment)

Menu: REG., M.DOWN, or REWRAP
 Mode: FIX, or BY COUNT

Up to 99 labels per PLU can be issued in non-scale mode. Up to 30 items can be preset. (However, if 0 is preset, issuing will be canceled.)

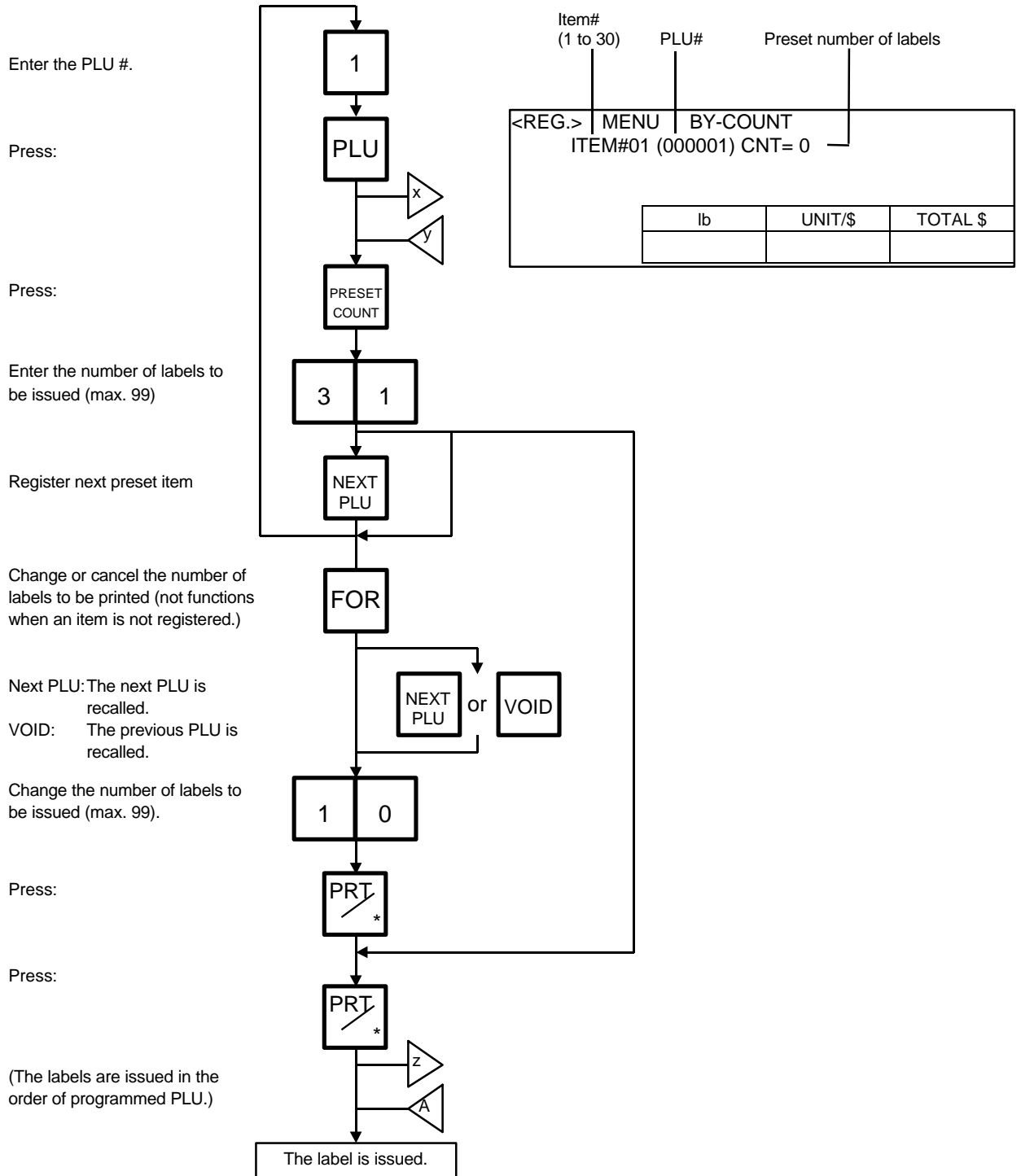

Changing a Unit Price and Calling G.Line/LOGO

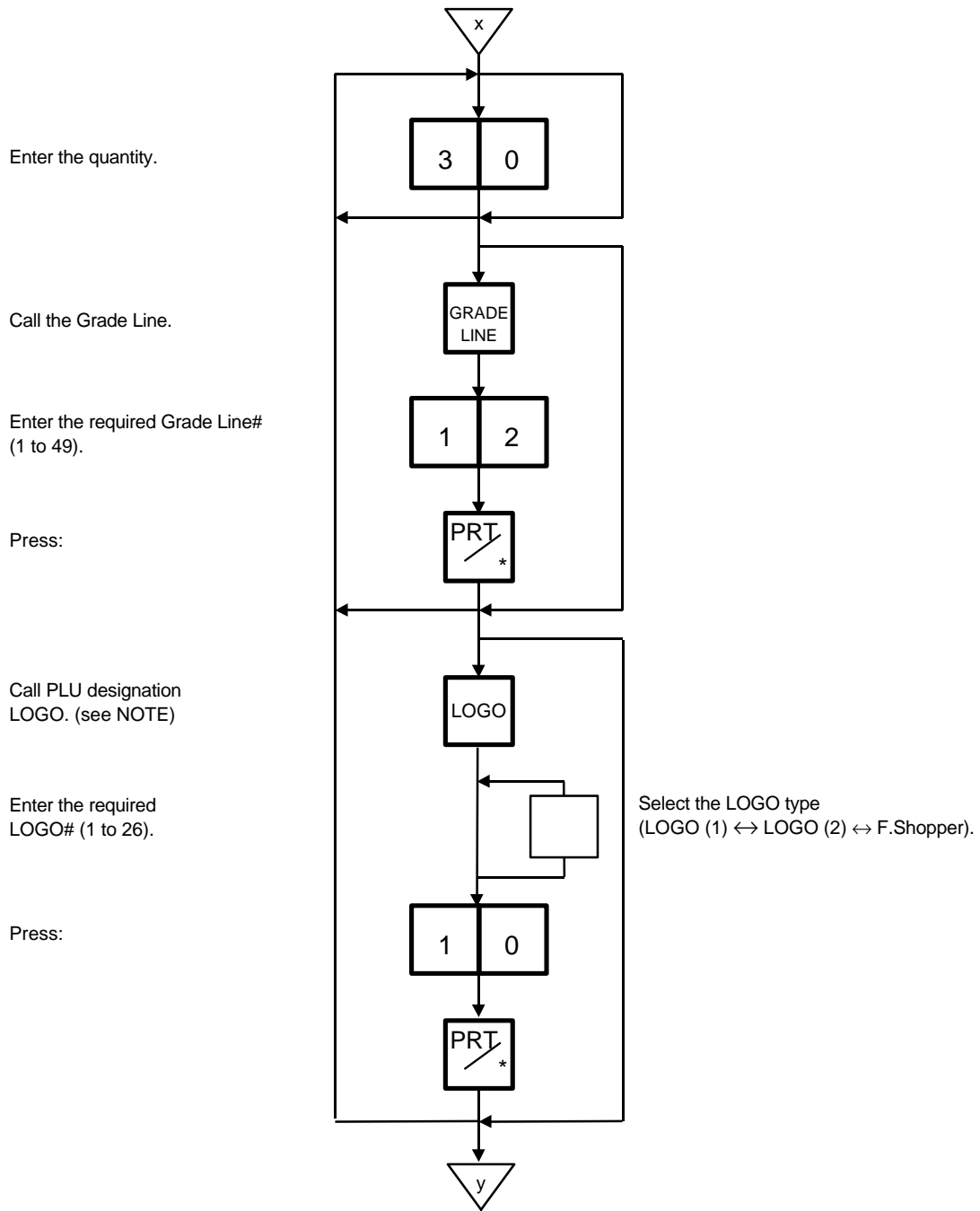

NOTE:

By calling the PLU designation LOGO, the LOGO can be designated per PLU and printed. When the PLU dose not designate the LOGO, the LOGO programmed before entering Batch Print Mode is printed.

Stopping or Canceling Label Issue

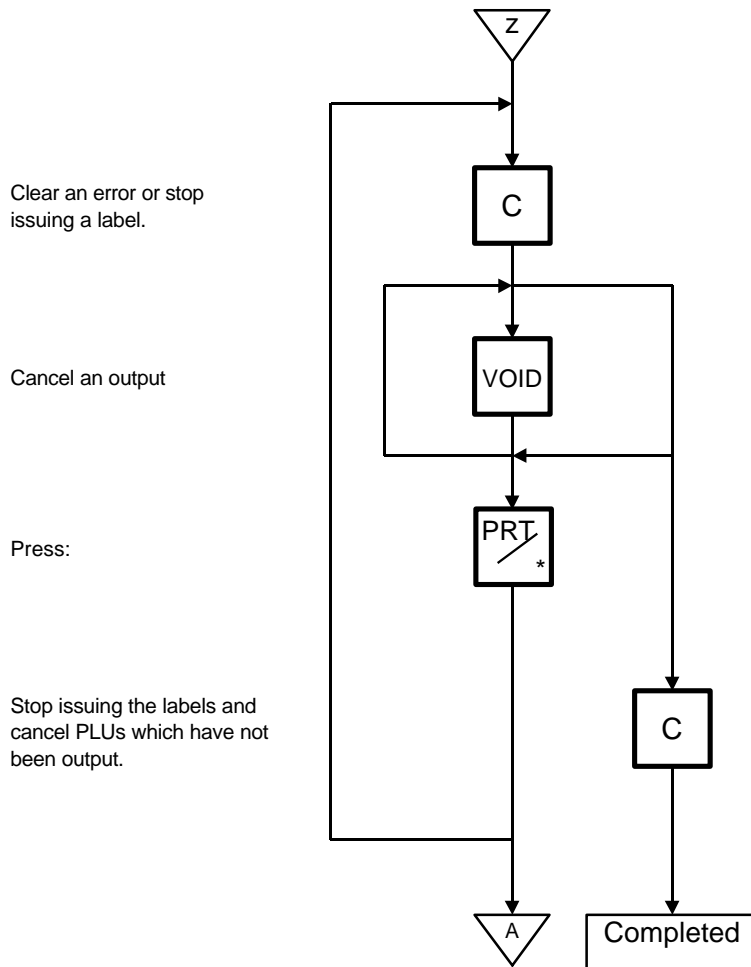

NOTES:

1. When the label for NET.WT statement is not selected, pressing the **PRESET COUNT** key in FIX mode results in an error.
2. Programmed items are reset when:
 - the power is off.*
 - changing the menu. (PROG./REG)*
 - changing the mode. (weight/by count/fix)*
 - batch printing has been finished.*
3. Pressing the **PRESET COUNT** key to preset the 31st item results in an error.
4. The LOGO and Grade Line called per PLU cannot be changed.
5. The label issued in Batch Print Mode cannot be corrected using the **VOID** key.
6. "TOTALS OVERFLOW" error occurs when the **PRINT** key is pressed to issue each PLU label.

13.12 VISUAL COMMODITY LIBRARY

Menu: REG., M.DOWN, or REWRAP

Mode: WEIGH, FIX, or BY COUNT

In the following procedure, entering a group # (the upper two digits of PLU#) allows you to call 6 commodities which belong to the group. This function is convenient when calling a commodity which PLU# you do not know.

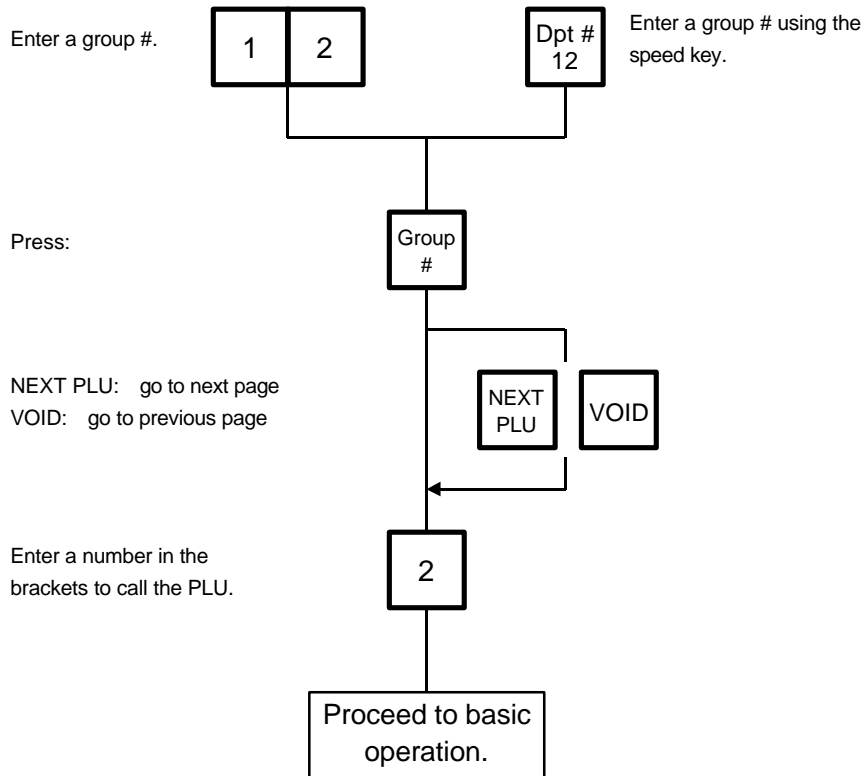

13.13 FLOATING VENDOR

Menu: REG

Mode: WEIGH, FIX, or BY COUNT

Floating vendor function allows you to register different commodities sales together. This function is available when the Initial Setting #11-1 is set to 1 and using a receipt.

Be sure to select IN-LINE in Section 11.15 LON SYSTEM even if no scale is connected, then enter the ID# 1, turn the power off and then on.

Maximum number of registerable commodities

One scale: 200 commodities

One vendor: 99 commodities

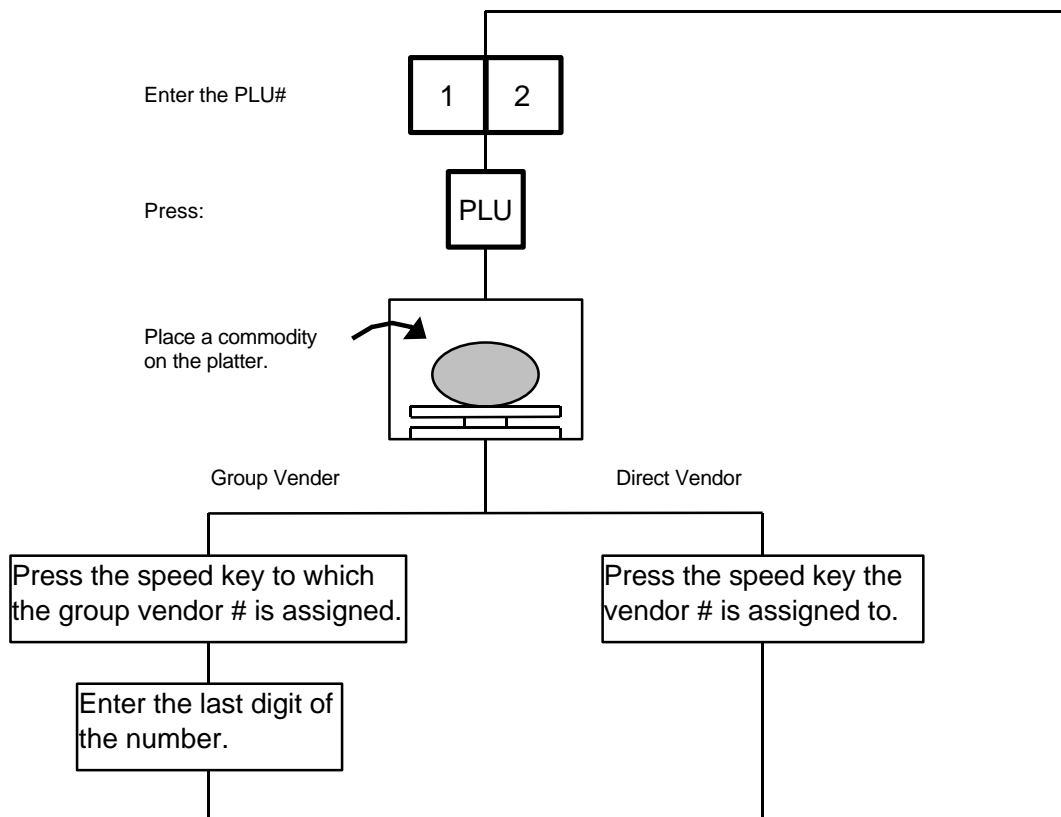

<REG.>			10	← vendor#
APPLE			1	← Item Count
1b	UNIT/\$	TOTAL \$		
1.000	1.00	1.00		

NOTE: Print format varies depending on the settings of the Initial Setting #11-1, 11-2, 11-3, 11-4 and 11-7.

Price deletion

Prices already registered can be deleted in the following procedure.

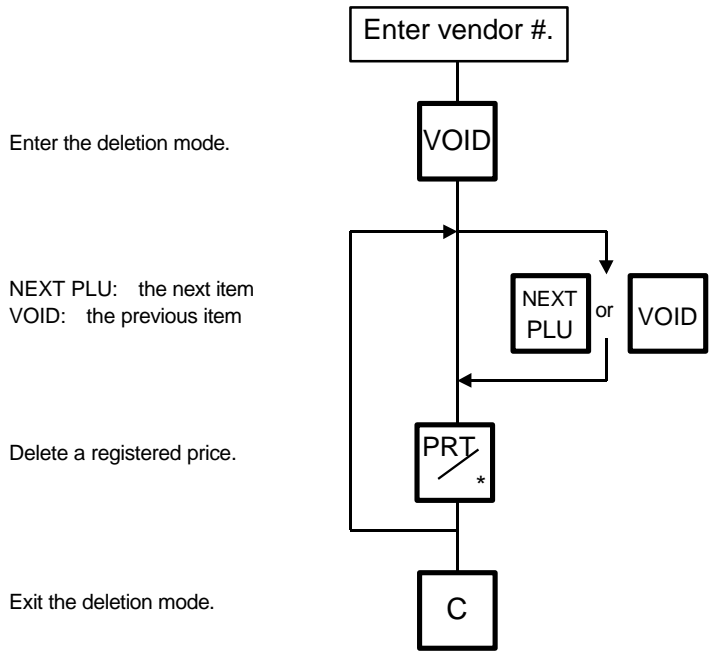

Subtotal

The following procedure will sum up all of the registered items.

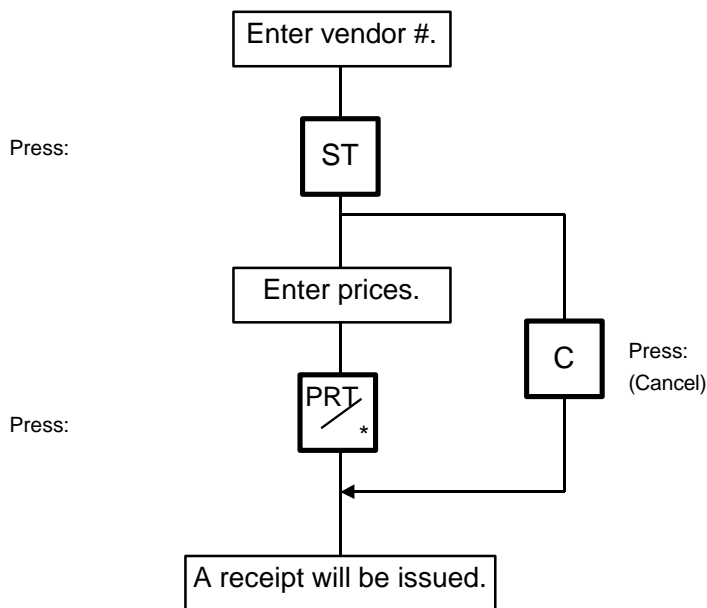

14. TOTAL OPERATION

In Report or Reset mode you can issue a sales report or reset report with either a label or journal paper.

Menu: REPORT or RESET

REPORT

The totals will not be cleared after they are printed on labels or journal paper.

RESET

The totals will be cleared after they are printed on labels or journal paper.

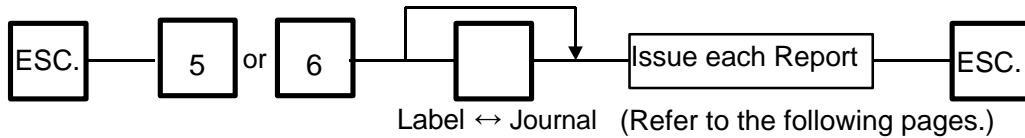

No.	ITEM	REPORT	RESET	JOURNAL	LABEL
0	HOURLY TOTAL				
1	GRAND TOTAL				
2	PLU TOTAL				
3	VENDOR TOTAL				

How to access REPORT or RESET menu

The following main menu is displayed after pressing the **ESC.** key. Enter '5' to enter the REPORT menu or '6' to enter the RESET menu. When those menus are protected, enter the menu No. and the password.

<Menu>	
0. PROG.	5. REPORT
1. REG.	6. RESET
2. MARK DOWN	7.
3. REWRAP	8.
4. SECURITY	9.

14.1 HOURLY TOTAL REPORT

Ex.) REPORT Menu

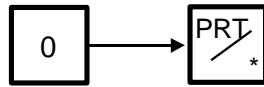

NOTE:

1. When issuing an hourly report, hours with no sales are not printed.
2. An hourly report is printed as follows:
 - 1) Label: Issued sequentially in on-demand mode.
 - 2) Journal paper: Issued with journal paper.
 - 3) Label with backing paper: Issued sequentially in batch mode.
3. If the **C** key is pressed during issuance, the hourly report being printed will be completed, then the total report will be issued. If this is done in Reset mode, the print data is cleared to zero.

14.2 GRAND TOTAL REPORT

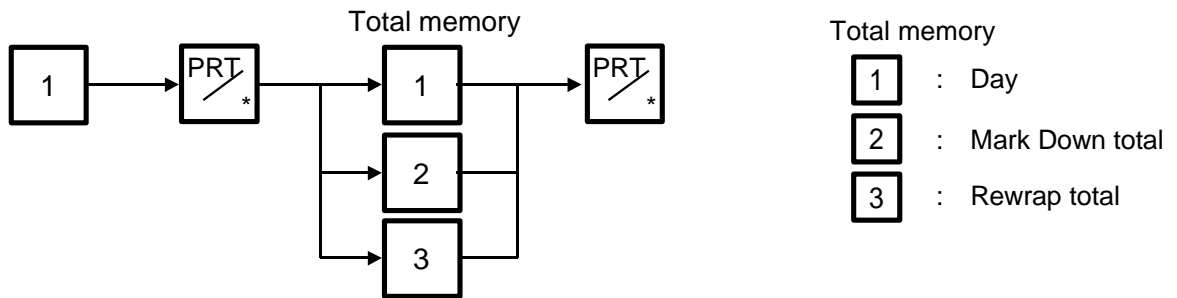

14.3 PLU TOTAL REPORT

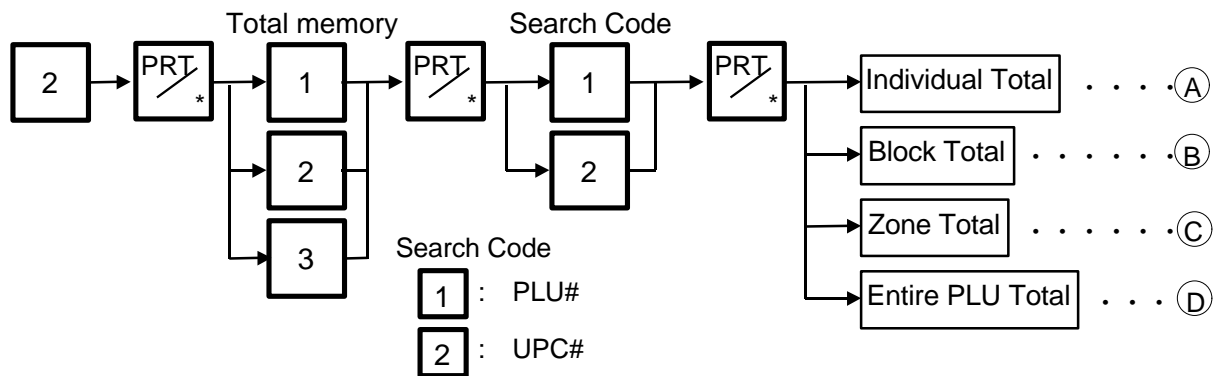

- Ⓐ Individual Total
Ex.) Individual PLU Total (PLU #100)

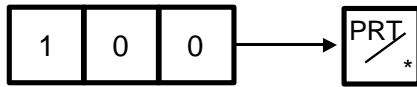

- Ⓑ Block Total
Ex.) UPC Block Total (UPC #100100 to 100199)

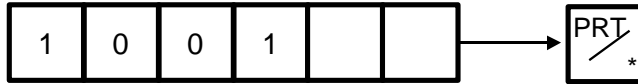

NOTE: The key represents 0 through 9. The most significant digit in the starting number is followed by an appropriate number of keys.

- Ⓒ Zone Total
Ex.) PLU Zone Total (PLU #100 to 107)

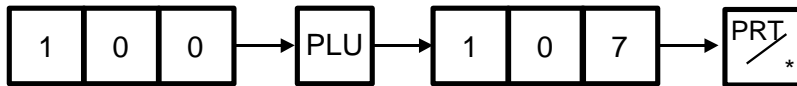

- Ⓓ Entire PLU Total



NOTES:

1. When setting the PLU zone, it is not necessary to enter the beginning number which is smaller than the end number.
2. When issuing a block or a zone total report, a PLU with no sales record is not printed. If all PLUs of the block or zone have no sales record, only the total is printed.
3. Pressing the key in the middle of issuing a reset report stops printing and data is not cleared.

14.4 VENDOR TOTAL REPORT

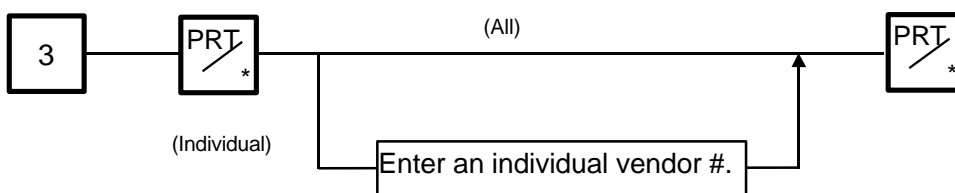

15. ERROR MESSAGE TABLE

Take the following action if an error message appears on the commodity name display along with the buzzer sounding.

WARNING!

If you cannot solve the problem with the following solution instruction, do not attempt further troubleshooting by yourself. Turn the power off, unplug the scale, then contact your Authorized Service representative for assistance.

Do not attempt to repair or adjust alone, because electrical equipment is dangerous.

Programming Mode

Message	Cause	Solution
DATA ENTRY ERROR	Error in key input.	Press the CLEAR key, and re-input the right data.
MEMORY FULL	No memory space to set PLU.	Press the CLEAR key, and delete unnecessary PLUs.
DUPLICATE PLU	The PLU # being changed is already registered.	Press the CLEAR key, and check the PLU.
PLU NOT FOUND	The PLU # being called is not registered.	Press the CLEAR key, and set the data to free PLU#.
CHARACTER OVERRUN	Attempt is made to set more than max. allowed number of characters.	Press the CLEAR key, and re-input the right data.
PRT FAILURE DETECTED	Printer trouble.	1. Check that the media and print head are set correctly. 2. If the label home position is misaligned, press the FEED key.
LABEL OVERRUN	Label overruns.	Press the FEED key.
RESTORE THE PLUS	The capacity of RAM was changed with the ingredient data stored.	Press the CLEAR key and save the ingredient data. Then delete the data from the memory of the unit. After that change the capacity of RAM and load the data to the unit.

Label Issue Mode

Message	Cause	Solution
DATA ENTRY ERROR	Error in key input.	Press the C key, and re-input the right data.
PLU NOT FOUND	The PLU # being called out is not registered.	Press the C key, and check the PLU #.
TOTALS OVERFLOW	GRAND TOTAL or PLU TOTAL memory has been exceeded at the time of issuing a label.	Press the C key, then the ESC. key and select 'RESET'. Then sum up the exceeded memory.
MEMORY WILL BE FULLED	The machine judges the memory is full before designated number of media are printed in Batch mode.	Press the C key, then the ESC. key and select 'RESET'. Then sum up the exceeded memory.
PLU DATA ERROR	Error in the PLU data.	Press the C key, and reprogram PLU data.
PRT FAILURE DETECTED	Printer trouble. Media end.	1. Check that the media and print head are set correctly. 2. If the label home position is misaligned, press the FEED key.
LABEL OVER RUN	Label overruns.	Press the FEED key.

Report and Reset Mode

Message	Cause	Solution
PLU NOT FOUND	Selected PLU # is not registered.	Press the C key, and enter the correct PLU #.
PRT FAILURE DETECTED	Printer trouble.	1. Check that the media and print head are set correctly. 2. If the label home position is misaligned, press the FEED key.
LABEL OVER RUN	Label overruns.	Press the FEED key.

CMT Operation Mode

Message	Cause	Solution
MISMATCH SCALE SPEC	Mismatch of the model type.	Press the CLEAR key
	Mismatch of the base unit.	
	Mismatch of the VERSION.	
	Mismatch of the TRANSMITTING DATA.	
	Mismatch of the scale capacity.	
BAD TAPE OR CMT	Parity error	Press the CLEAR key
	Framing error	
	Overrun error	
	Data error	
	Two or More Hardware error	
TIME OUT ERROR	Time out error	Press the CLEAR key.

LON System Mode

Message	Cause	Solution	M	BM/S
COMMUNICATION ERROR	1. The power of the master or backup master scale is not turned ON. They are not connected with each other or in off-line state. 2. LON cable is broken.	1. Turn the power of the master or backup master scale ON. Connect them with each other or turn the scale in-line. 2. Call your authorized service representative.		
SEQUENCE ERROR	The power was not turned OFF and ON again after setting ID #.	Turn the power switch OFF and ON again.		
SEQUENCE NO. ERROR	Text data number is incorrect.	Call your authorized service representative.		
MASTER BUSY	Registration job is performed on a satellite scale while reset job is performed on the master scale.	1. Quit reset job on the master scale. 2. Quit registration job on the satellite scale.		
BACKUP MASTER NOT RESET	The backup master does not have the same PLU with the master scale.	Down load PLU from the master to the backup master scale. Then run the reset operation again.		
TEXT ERROR ##	1. Error text is found. 02: Sequence No. error 05: LRC error 08: Text error 09: Command error 2. The master scale differs from other scale in ROM version.	Call your authorized service representative.		

M: Master scale BM: Backup master scale S: Satellite scale

16. CLEANING THE PRINT HEAD

WARNING!

Care must be taken not to injure your fingers with the receipt cutter during installing, removing or cleaning it.

If the print head is dirty, printing will not be clear. The print head should be cleared with a print head cleaner everyday before use, according to the following procedure:

1. Open the printer cover and turn the head-up lever to the anticlock wise. (See page 8-1)
2. Clean the print head element with the print head cleaner.

NOTE: Be careful not to damage the print head when cleaning.

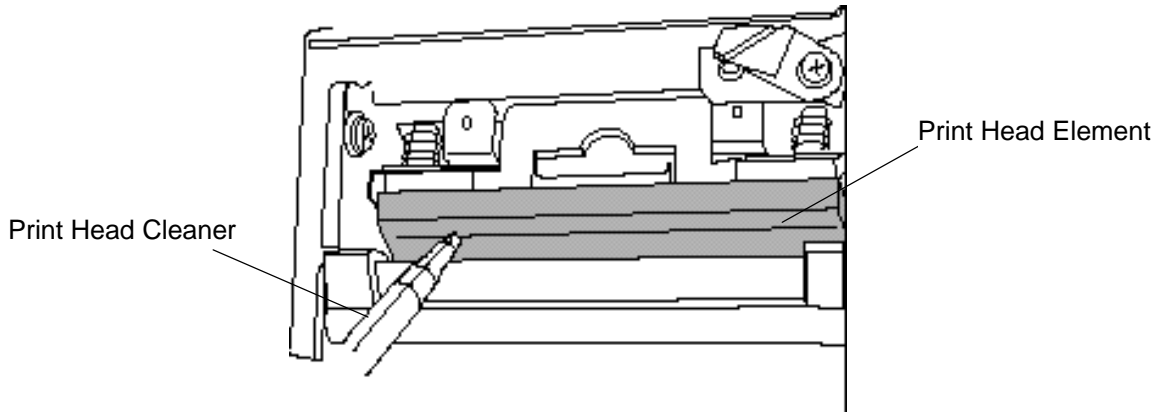

3. If any label paste is found on the label cutter, wipe off the paste with alcohol.

After removing the label cutter, reattach it using the following procedure.

1. Remove the receipt/label from the scale.
2. Install the label cutter, aligning the cutter notches with the screw holes.
3. Secure the cutter with the screws (B-3x6) so the bottom of the cutter is 0.5 to 0.8 mm above the peel-off plate.

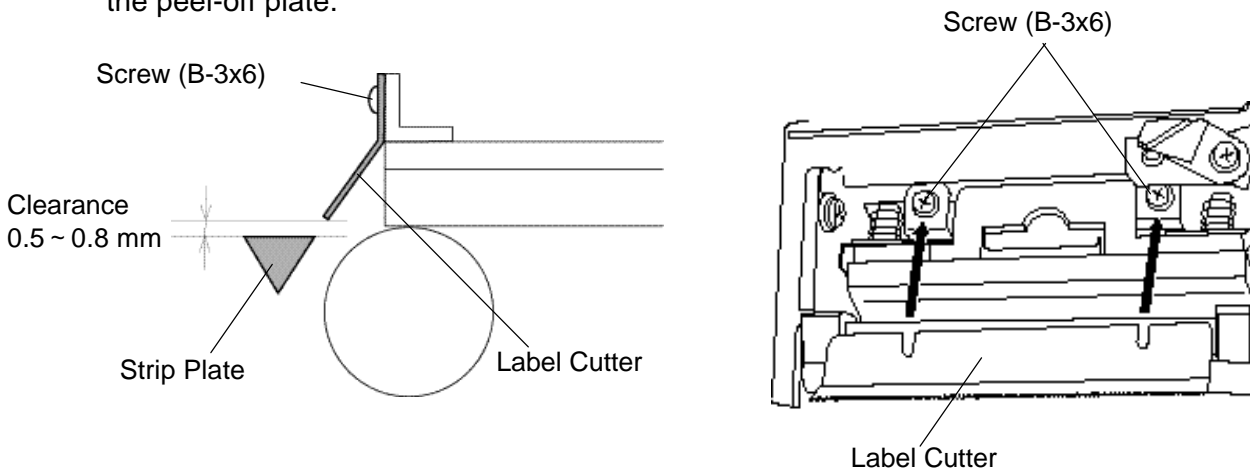

NOTES:

1. If the cutter is scratching labels during printing, increase the clearance between the cutter and the peel-off plate.
2. When the cutter is stained with glue or paper dust, clean it with a cotton swab moistened with alcohol.

17. TROUBLESHOOTING

WARNING!

This scale has been manufactured under strict quality control. If you have any trouble, however, DO NOT ATTEMPT TO FIX IT BY YOURSELF. Pull the power plug out of the outlet, and contact the TOSHIBA TEC Authorized Service Representative.

Problems	Solution
" - - - - " is displayed at power on.	Was the power turned ON when something was on the platter? Make sure nothing is on the platter and turn the power on again. Is the platter mounted correctly? Mount the platter correctly and turn the power on again.
Display unstable.	Is anything touching the platter? If so, remove it. Is the machine in a windy location? Avoid locations subject to the wind.
No print.	1. Check that the media is loaded correctly. 2. Check whether the print head is set correctly or not.
Dots missing in the print.	Dirty print head. Clean the print head. Call your Authorized Service representative if necessary.
Unclear (or blurred) printing.	1. Dirty print head. Clean the print head. 2. Poor media quality. Change media type.
Power does not come on.	1. Plug the power cord into an AC socket. 2. Check the circuit breakers or fuses. 3. Plug another appliance into the AC socket to check if there is power supplied. Call your Authorized Service representative if necessary.
You see a raised nap where the media has been cut.	1. Clean the cutter blades. 2. The blades are worn. Call your Authorized Service representative.

Before You Call for Service

It is our primary concern to give you full satisfaction and better service. If, however, any problem arises in connection with the operation of this scale, please check the following points before calling for service:

- A) Is the power plug fully plugged into an AC outlet?
- B) Is the power turned ON?
- C) Is AC power being properly supplied to the outlet? (Check it using another electric appliance.)
- D) Check the circuit breaker.
- E) Has there been a power failure of any sort?
- F) Has the operation been carried out in the correct order?



TEC
TOSHIBA TEC CORPORATION

 PRINTED IN SINGAPORE
EO1-32003B